

18 CHANNEL CONFLICT MONITOR PROGRAMMING DETAIL

(remove jumpers and set switches as shown)

REMOVE DIODE JUMPERS I-2, I-5, I-6, I-7, I-11, 2-5, 2-6, 2-7, 2-11, 5-6, 5-7, 5-9, 6-9, 7-9, 7-11 and 9-11.

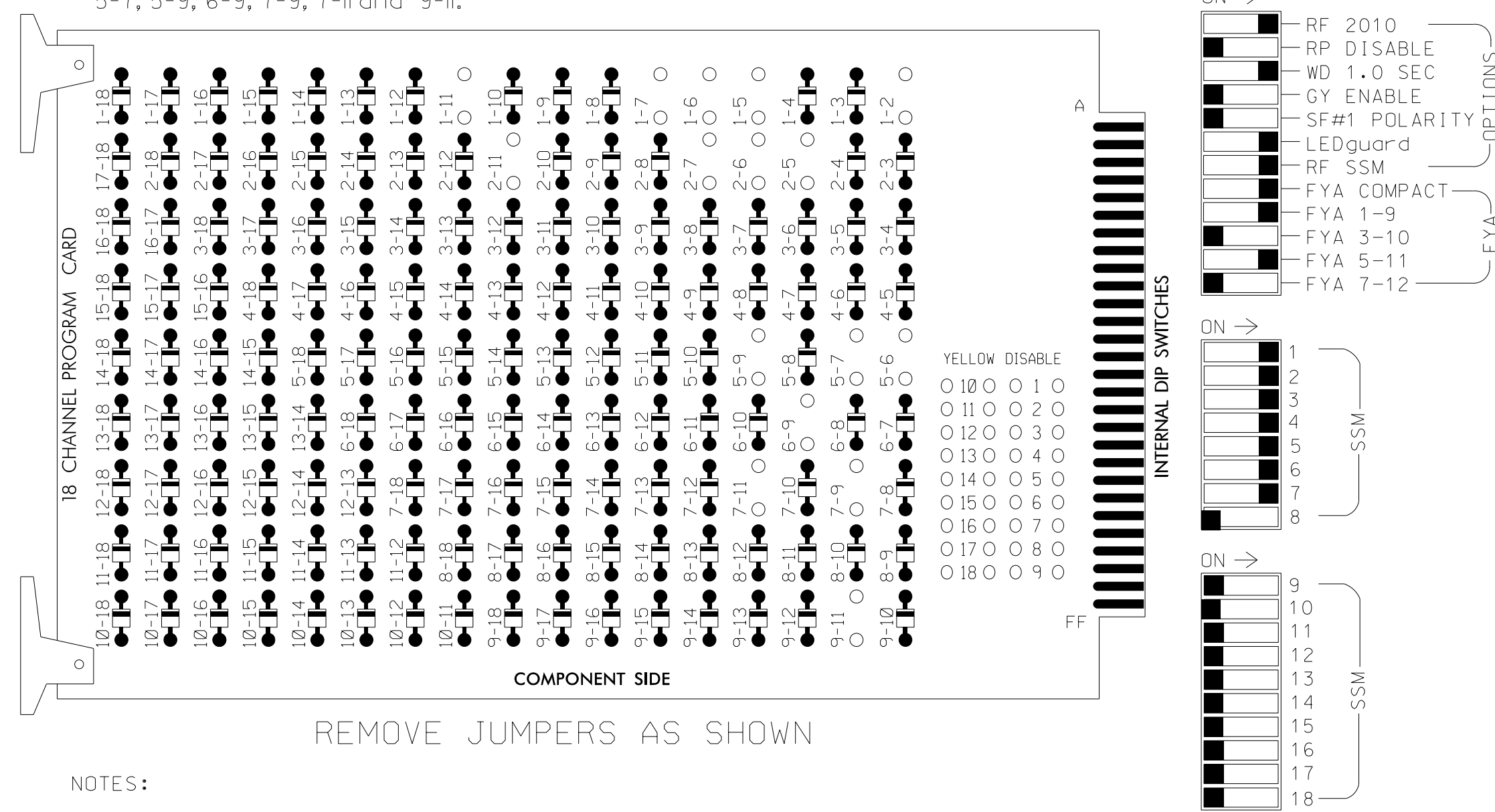

REMOVE JUMPERS AS SHOWN

NOTES:

- Card is provided with all diode jumpers in place. Removal of any jumper allows its channels to run concurrently.
- Ensure jumpers SEL2-SEL5 and SEL9 are present on the monitor board.
- Ensure that Red Enable is active at all times during normal operation.
- Connect serial cable from conflict monitor to comm. port 1 of 2070 controller. Ensure conflict monitor communicates with 2070.

! Special cabinet wiring is required to utilize FYA COMPACT mode. See Ped Yellow Conflict Monitor Wiring Detail on this sheet. !

NOTES

- To prevent "flash-conflict" problems, insert red flash program blocks for all unused vehicle load switches in the output file. The installer shall verify that signal heads flash in accordance with the Signal Plans.
- Enable Simultaneous Gap-Out for all Phases.
- Program phases 2 and 6 for Variable Initial and Gap Reduction.
- Program phases 2 and 6 for Startup In Green.
- Program phases 2 and 6 for Yellow Flash, and overlap 1 as Wag Overlap.
- The cabinet and controller are part of the Winston-Salem Signal System.

EQUIPMENT INFORMATION

CONTROLLER.....2070
 CABINET.....336
 SOFTWARE.....ECONOLITE OASIS
 CABINET MOUNT.....PDLE
 OUTPUT FILE POSITIONS...12
 LOAD SWITCHES USED.....S1,S2,S3,S4,S5,S7,S8,S9,S10
 PHASES USED.....1,2,3,4,5,6
 OVERLAP "A".....1+2
 OVERLAP "B".....NOT USED
 OVERLAP "C".....5+6
 OVERLAP "D".....NOT USED
 OVERLAP "E".....5

INPUT FILE POSITION LAYOUT

(front view)

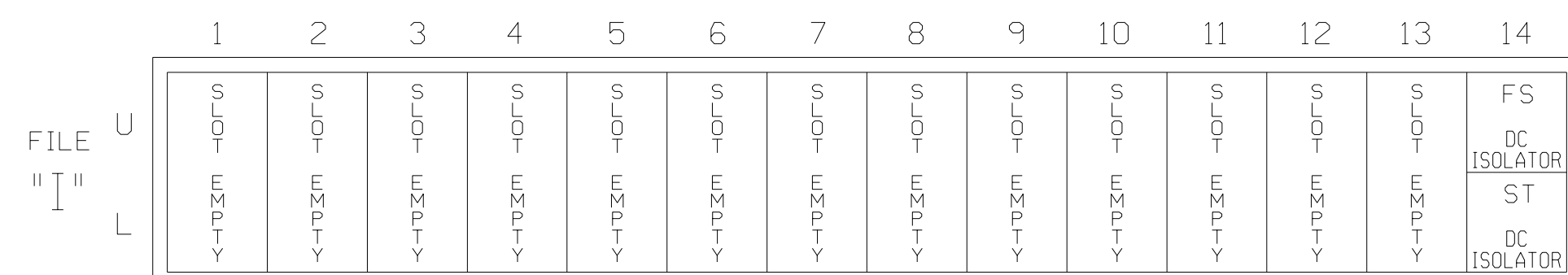

SPECIAL DETECTOR NOTE

Install a video detection system for vehicle detection. Perform installation according to manufacturer's directions and NCDOT engineer approved mounting locations to accomplish the detection schemes shown on the Signal Design Plans.

PED YELLOW CONFLICT MONITOR WIRING DETAIL

(make cabinet wiring changes as shown below)

In order to use FYA COMPACT mode, the cabinet must be wired such that the (unused) Ped Yellow load switch outputs are wired to the conflict monitor as follows: From 2 PY (field term. 114) to chan. 9 green (monitor pin 13), and from 6 PY (field term. 120) to chan. 10 green (monitor pin R).

Follow the instructions below to make the appropriate connections:

- STEP 1: Fold down rear panel of output file.
 STEP 2: Find unused wiring harness from conflict monitor card edge connector (which should be tied and bundled together).
 STEP 3: Find the conductors that correspond to the following conflict monitor card edge pins and solder wire to the appropriate terminal on the rear of the output file as shown below:

CMU-13 _____ 2PY (term. 114)
 CMU-R _____ 6PY (term. 120)

NOTE: Some cabinet manufacturers use keyed connectors to accomplish this wiring configuration. If connectors are used, fold down the rear panel of the output file and find the set of 3 keyed connectors and connect them as shown below:

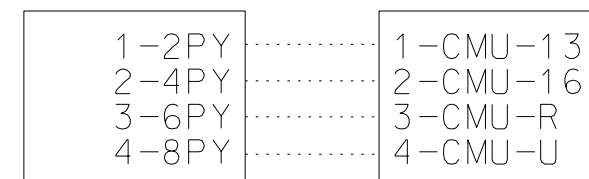

THIS ELECTRICAL DETAIL IS FOR THE SIGNAL DESIGN: 09-0699T1
 DESIGNED: March 2023
 SEALED: April 25, 2023
 REVISED:

SIGNAL HEAD HOOK-UP CHART

LOAD SWITCH NO.	S1	S2	S3	S4	S5	S6	S7	S8	S9	S10	S11	S12				
CMU CHANNEL NO.	1	2	9	13	3	4	14	5	6	11	15	7	8	16		
PHASE	OLA	2	1 GRN	2 PED	3	4	4 PED	OLC	6	5 GRN	6 PED	OLE	8	8 PED		
SIGNAL HEAD NO.	11	21,22	11	NU	31	32	41	42	NU	51	61,62	51	NU	42	NU	NU
RED		128			116	116	101	101			134			*		
YELLOW		129			117	117	102	102			135					
GREEN		130			118	118	103	103			136					
RED ARROW	125										131					
YELLOW ARROW	126										132				123	
FLASHING YELLOW ARROW	127										133					
GREEN ARROW					114		118		103				120		124	

NU = Not Used

* Denotes install load resistor. See load resistor installation detail this sheet.

★ See pictorial of head wiring in detail this sheet.

FYA SIGNAL WIRING DETAIL

(wire signal heads as shown)

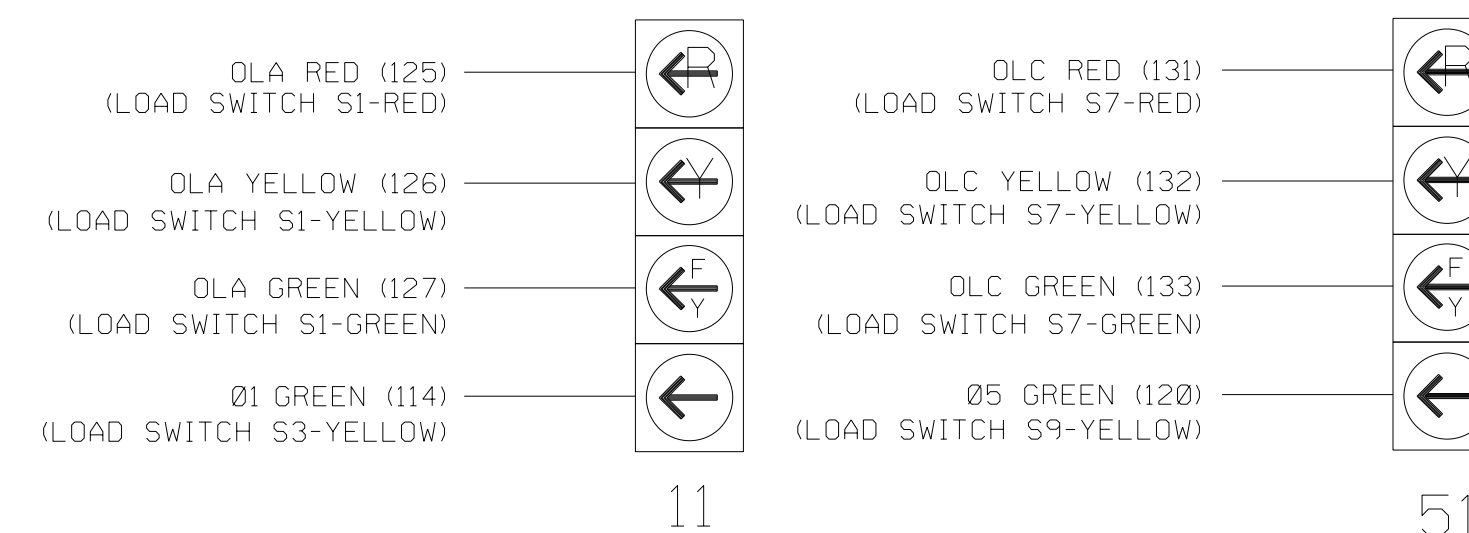

NOTE

The sequence display for signal heads 11 and 51 require special logic and output remapping. See sheet 2 for programming instructions.

LOAD RESISTOR INSTALLATION DETAIL

(install resistors as shown below)

ACCEPTABLE VALUES	
VALUE (ohms)	WATTAGE
1.5K - 1.9K	25W (min)
2.0K - 3.0K	10W (min)

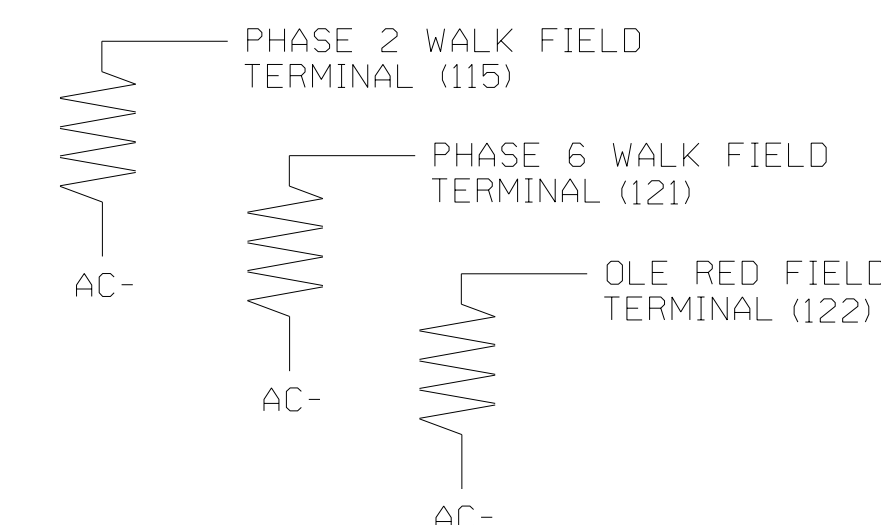

ELECTRICAL AND PROGRAMMING DETAILS FOR:

SR 1672 (Hanes Mill Road) at Museum Drive
 Division 9 Forsyth County Winston-Salem
 PLAN DATE: March 2023 REVIEWED BY: RW Thompson
 PREPARED BY: LD Stouchko REVIEWED BY:

DOCUMENT NOT CONSIDERED FINAL UNLESS ALL SIGNATURES COMPLETED

4/25/2023 6:40:35.00.DOC - 1246C_U-2729*Tranff.c*SignalS*09-0699*60_020_050699-20230425e1-t1.dgn User:STDB627