

TIP NO.	SHEET NO.
U-4424	SIGN-1
APPROVED: 	
DATE: 5/2/2023	
	
DOCUMENT NOT CONSIDERED FINAL UNLESS ALL SIGNATURES COMPLETED	

**STATE OF NORTH CAROLINA  
DEPARTMENT OF TRANSPORTATION**

**SIGNING PLAN  
EDGECOMBE COUNTY**

**LOCATION: NC 111 (WILSON STREET) FROM NC 122 (MCNAIR ROAD) TO  
US 64 ALTERNATE (WESTERN BOULEVARD)**

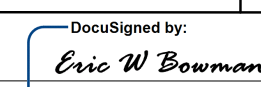
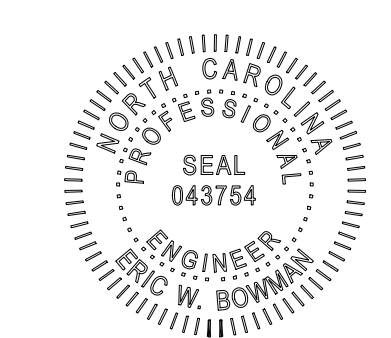
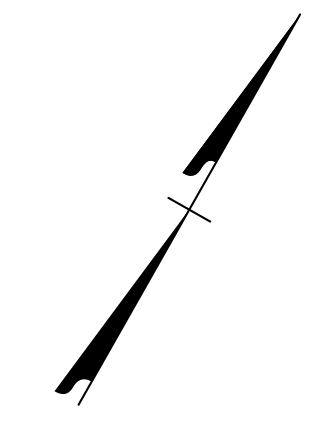
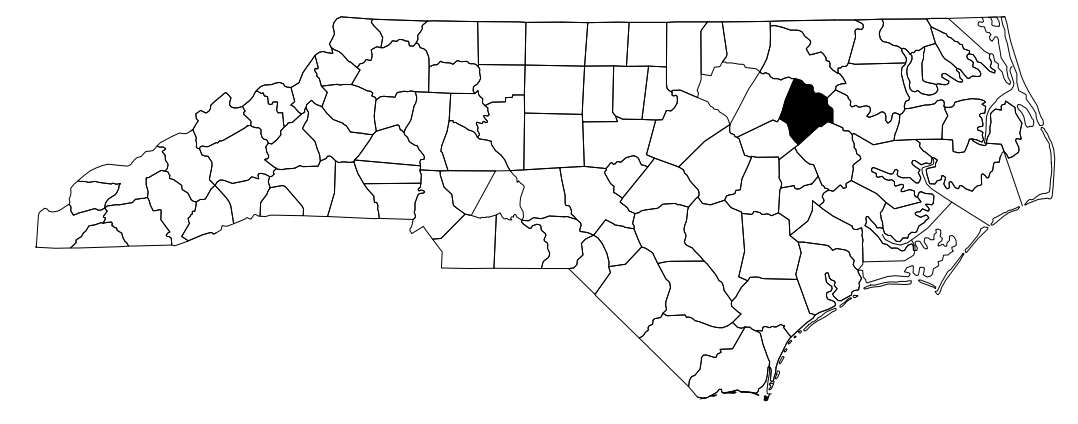

**T.I.P.: U-4424**

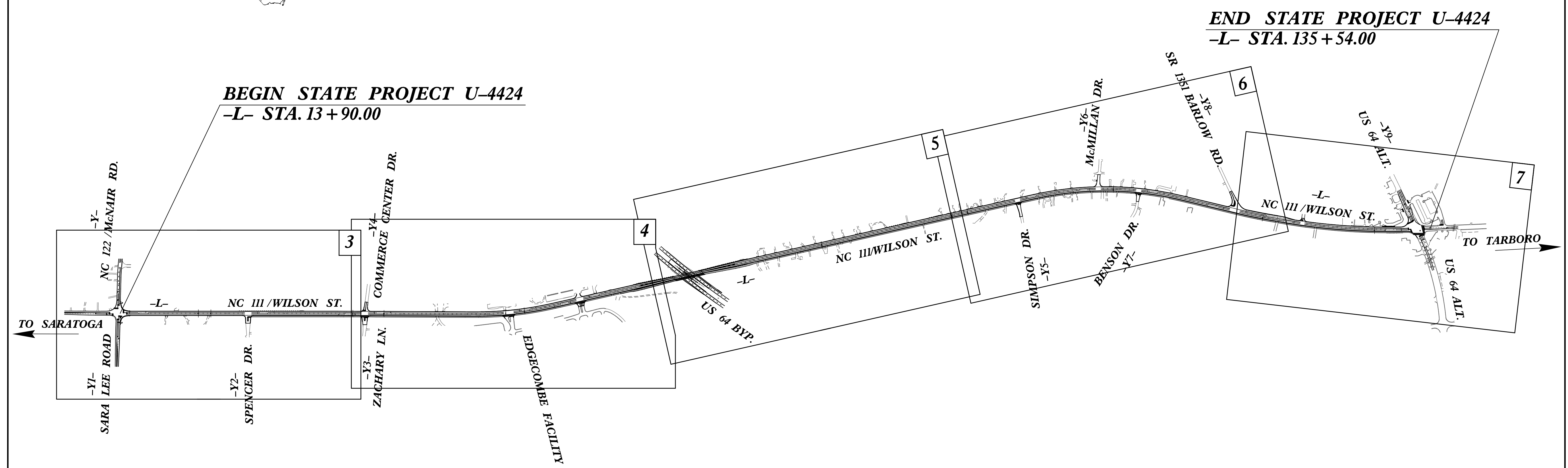

<b>INDEX</b>	
SHEET NO.	DESCRIPTION
SIGN-1	TITLE SHEET
SIGN-1A	ROADWAY STANDARD DRAWINGS, GENERAL NOTES, PROJECT NOTES, & SUMMARY OF QUANTITIES
SIGN-1B	REVISED ROADWAY STANDARD DRAWING
SIGN-2	TYPE D SIGN DESIGNS
SIGN-2A TO 2B	TYPE E AND F SIGNS
SIGN-3 TO SIGN-7	SIGNING SHEETS

**CONTRACT:**

<b>PLAN SUBMITTED TO: N.C.D.O.T. SIGNING AND DELINEATION UNIT</b>	
<u>AYMAN I. ALQUDWAH, PE</u>	SIGNING & DELINEATION REGIONAL ENGINEER
<u>MITCH EATON, PE</u>	SIGNING & DELINEATION PROJECT DESIGN ENGINEER

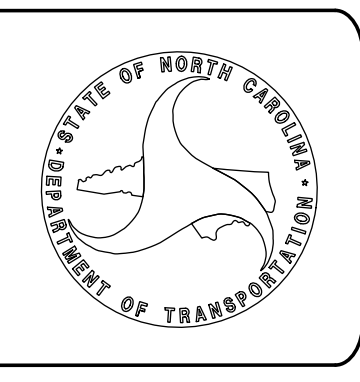

<b>PLAN PREPARED BY: WSP</b>	
<u>ERIC BOWMAN, PE</u>	PROJECT TRAFFIC ENGINEER
<u>ROBIN HUELSBECK, PE</u>	PROJECT TRAFFIC DESIGN ENGINEER

**wsp**

1001 Morehead Square Dr., Suite 610,  
Charlotte NC, 28203  
NC LIC NO. F-0165

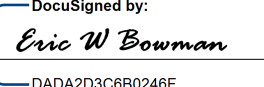
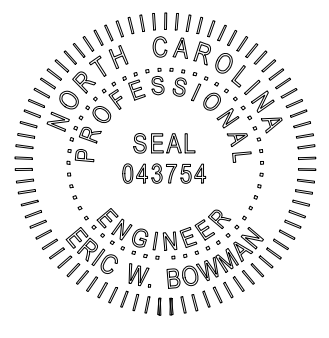
TIP NO.	SHEET NO.
U - 4424	SIGN - 1A
APPROVED:  <small>DocuSigned by: Eric W. Bowman DADA203C6B0246F</small>	
DATE: 5/2/2023	
SEAL	
	
<b>DOCUMENT NOT CONSIDERED FINAL UNLESS ALL SIGNATURES COMPLETED</b>	

**ROADWAY STANDARD DRAWING**

THE FOLLOWING ROADWAY STANDARDS AS APPEAR IN "ROADWAY STANDARD DRAWINGS" - PROJECT SERVICES UNIT - N.C. DEPARTMENT OF TRANSPORTATION - RALEIGH, N.C., DATED JANUARY 2018 ARE APPLICABLE TO THIS PROJECT AND BY REFERENCE HEREBY ARE CONSIDERED A PART OF THESE PLANS:

STD. NO.	TITLE
904.10	ORIENTATION OF GROUND MOUNTED SIGNS
904.50	MOUNTING OF TYPE 'D', 'E' AND 'F' SIGNS ON 'U' CHANNEL POSTS SHEET 2 OF 2

**GENERAL NOTES**

- . ALL TYPE 'D' SIGNS SHALL BE MOUNTED ON TWO U-CHANNEL POSTS UNLESS OTHERWISE INDICATED ON THE PLANS.
- . IF REMOVAL OR RELOCATION OF SIGNS ON PRIVATE STREET (NON-STATE MAINTAINED) IS REQUIRED DUE TO CONSTRUCTION, THE CONTRACTOR SHALL INFORM THE ENGINEER. THE WORK WILL BE COMPLETED BY OTHERS.
- . WHEN NOT STATIONED OR DIMENSIONED ON PLANS, ALL 'E' AND 'F' SIGNS SHALL BE FIELD LOCATED BY THE ENGINEER
- . ALL EXISTING SIGNS ON "U" CHANNEL POST WITHIN THE PROJECT LIMITS SHALL BE REMOVED AND DISPOSED OF UNLESS OTHERWISE NOTED ON PLANS.
- . WHEN EXISTING SIGNS ARE REMOVED AND INSTALLED ON NEW SUPPORTS, THE RE-ERECTION SHALL IMMEDIATELY FOLLOW THE REMOVAL.
- . THE BACKGROUND FOR TYPE E & F SIGNS SHALL BE TYPE C REFLECTIVE SHEETING.
- . DO NOT BEGIN FABRICATION FOR TYPES A & B SIGNS MOUNTED ON OVERHEAD STRUCTURES OR STEEL SUPPORTS UNTIL "S" DIMENSIONS HAVE BEEN FIELD VERIFIED.
- . SEE ROADWAY PLANS FOR GUARD/GUIDE RAIL DETAILS.

**REVISED ROADWAY STANDARD DRAWING**

THE FOLLOWING REVISED ROADWAY STANDARDS ARE USED ON THIS PROJECT:

STD. NO.	TITLE
904D50	MOUNTING OF TYPE 'D', 'E' AND 'F' SIGNS ON 'U' CHANNEL POSTS SHEET 1 OF 2 (SEE SIGN-1B)

**PROJECT NOTES**

- 1 DISPOSAL OF SIGN SYSTEM (WOOD)
- 2 DISPOSAL OF SIGN SYSTEM (U CHANNEL)
- 3 RELOCATE SIGN, TYPE D
- 4 DISPOSAL OF SUPPORT (U-CHANNEL)

**SUMMARY OF QUANTITIES**

ITEM NO.		ITEM DESCRIPTION	QUANTITY	UNIT
DESC. NO.	SECT. NO.			
4025000000	901	CONTRACTOR FURNISHED, TYPE D SIGN	7	S.F.
4025000000	901	CONTRACTOR FURNISHED, TYPE E SIGN	330	S.F.
4025000000	901	CONTRACTOR FURNISHED, TYPE F SIGN	120	S.F.
4072000000	903	SUPPORTS, 3 LB STEEL U-CHANNEL	875	L.F.
4096000000	904	SIGN ERECTION, TYPE D	1	EA.
4102000000	904	SIGN ERECTION, TYPE E	42	EA.
4108000000	904	SIGN ERECTION, TYPE F	9	EA.
4116100000	904	SIGN ERECTION, RELOCATE SIGN TYPE D	11	EA.
4155000000	907	DISPOSAL OF SIGN SYSTEM, U-CHANNEL	37	EA.
4158000000	907	DISPOSAL OF SIGN SYSTEM, WOOD	12	EA.
4192000000	907	DISPOSAL OF SUPPORT, U-CHANNEL	11	EA.

**ROADWAY STANDARD DRAWINGS,  
GENERAL NOTES & SUMMARY  
OF QUANTITIES**

3/13/2023 2:16:71-06 NCDOT NC 111\U-4424\Traffic\Signing\CADD\Signing Layout\Plans\Sheets\U-4424\_sgn\_SIGN-1A.dgn  
 USER:04421

TIP NO.	SHEET NO.
DocuSigned by: <i>Matthew V. Springer</i>	
APPROVED: 6/23/2021 10:44:03 AM	
DATE: 6/23/2021	
SEAL	



STATE OF NORTH CAROLINA  
DEPT. OF TRANSPORTATION  
DIVISION OF HIGHWAYS  
RALEIGH, N.C.

6-21

ENGLISH DETAIL DRAWING FOR  
MOUNTING OF  
TYPE 'D', 'E' AND 'F' SIGNS  
ON 'U' CHANNEL POSTS

SHEET 1 OF 2  
904D50

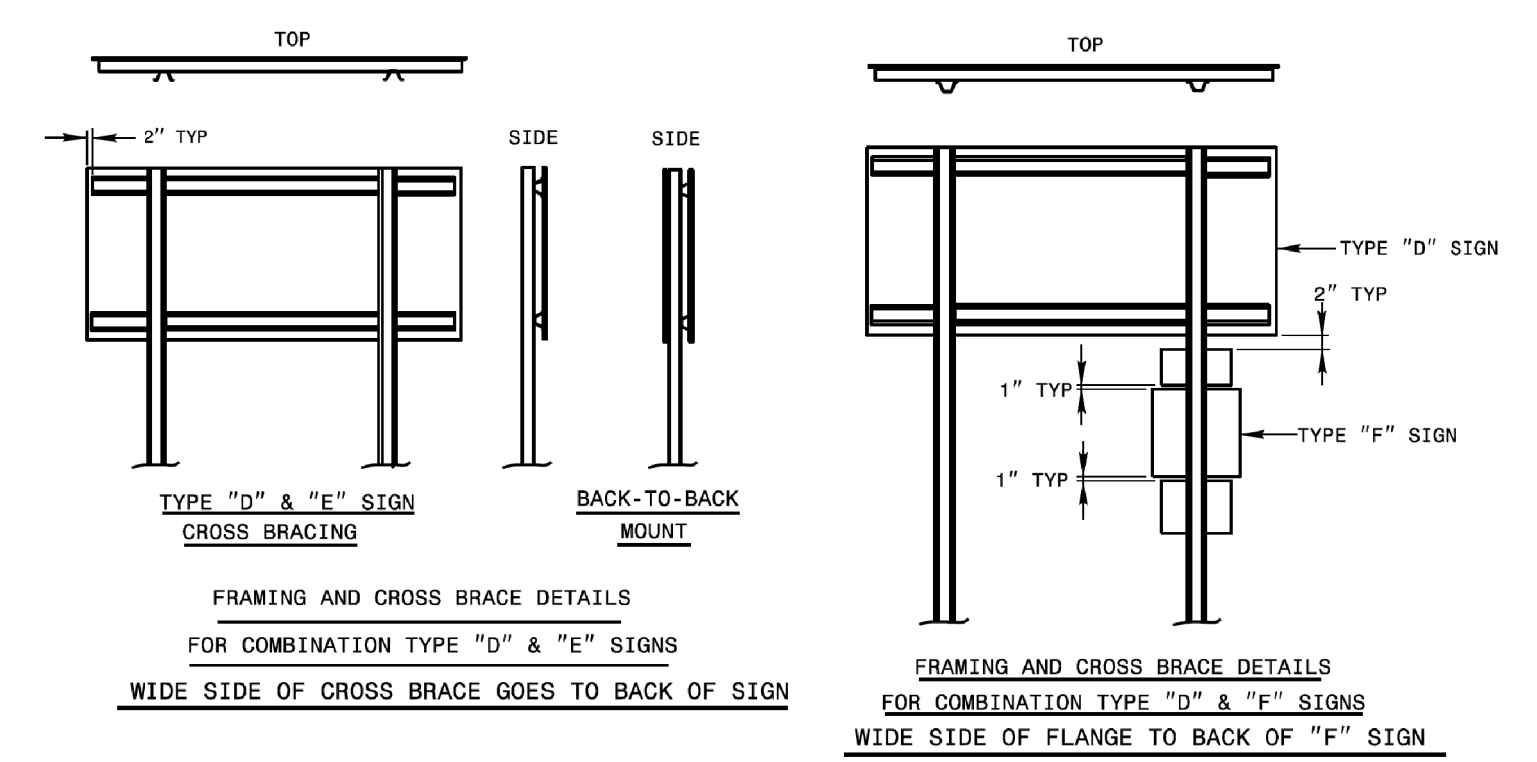
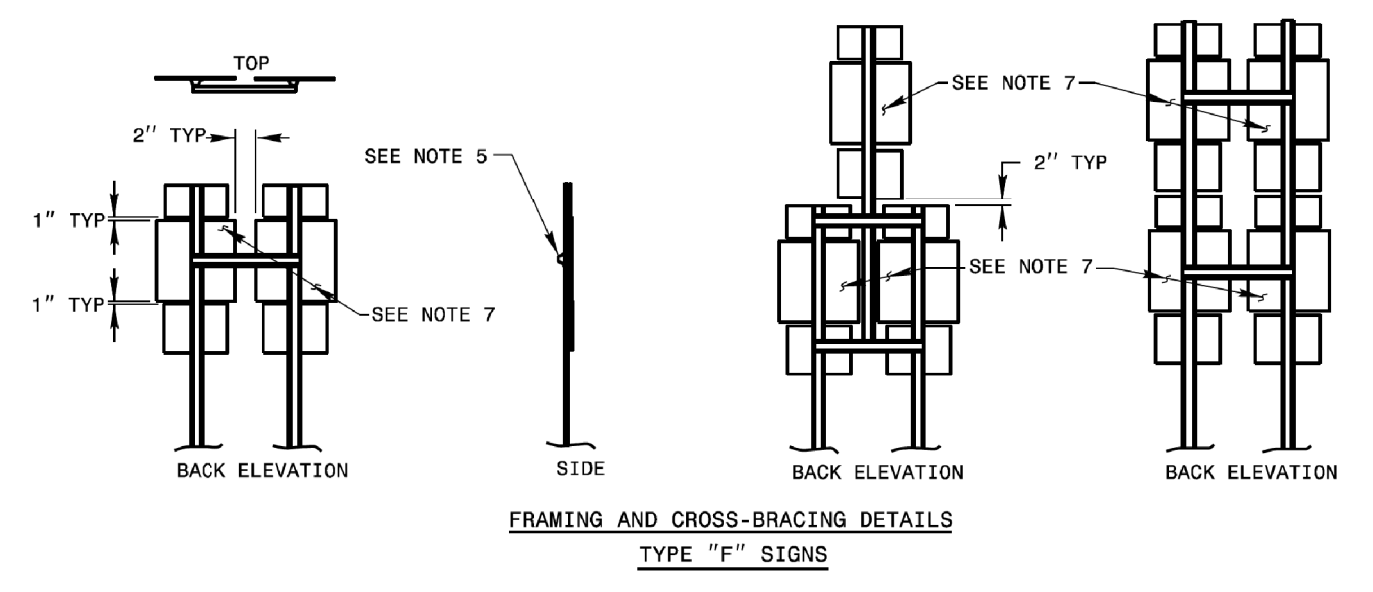
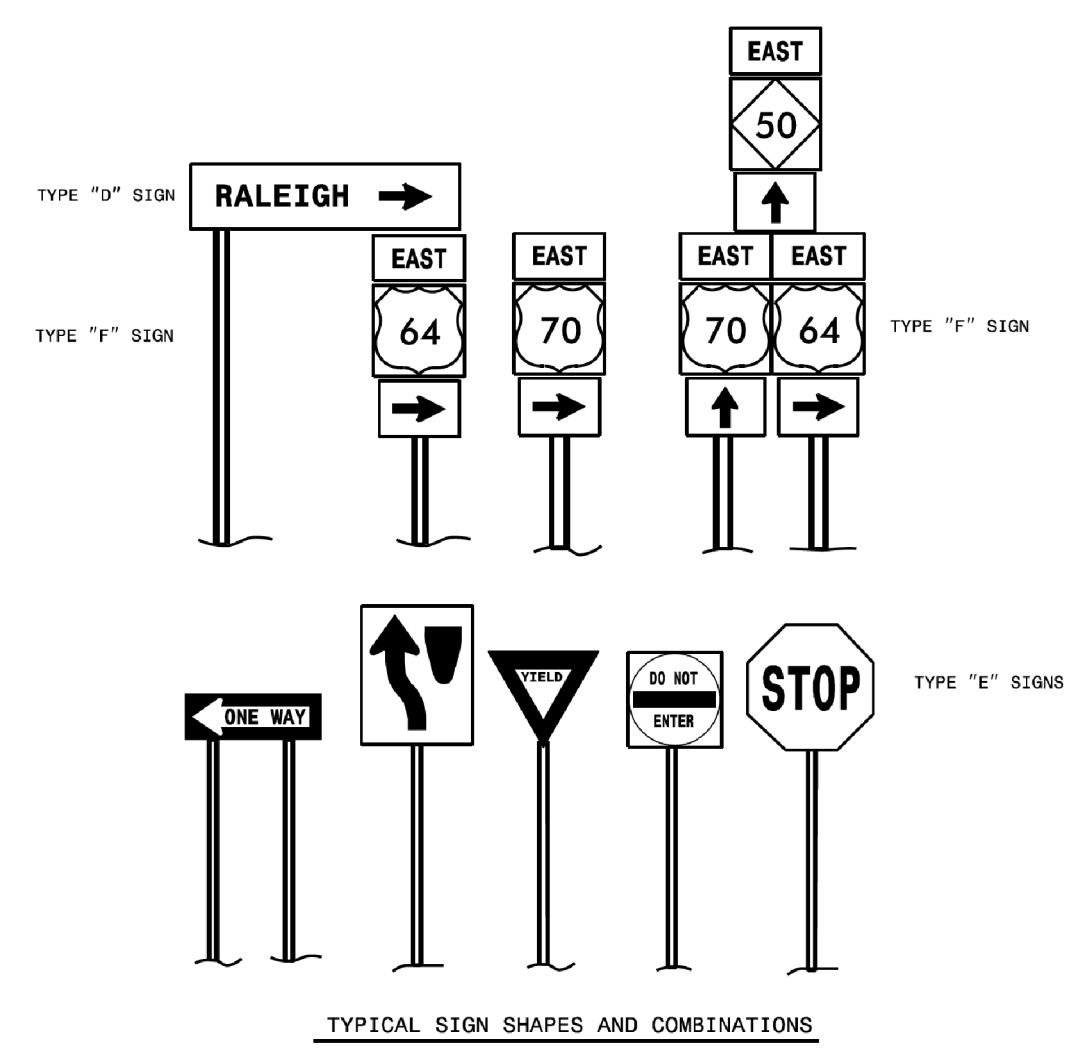
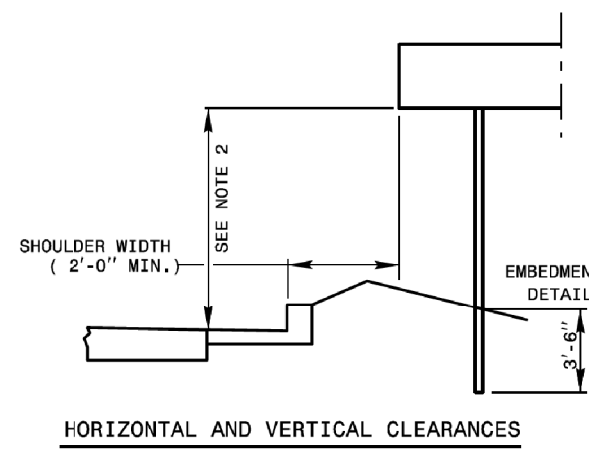
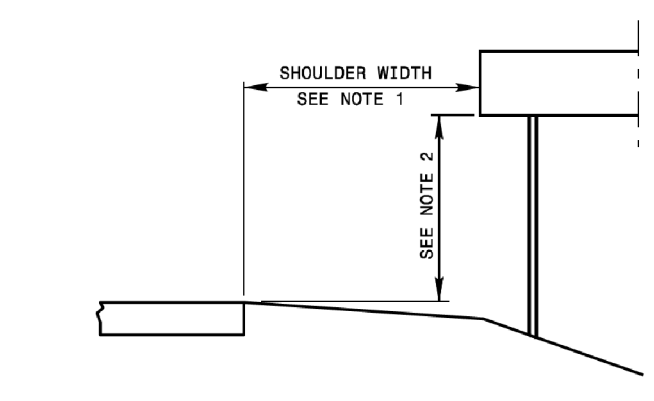

- NOTES:
- ERECT TYPE "D", "E", AND "F" SIGNS ON FREEWAYS WITH THE NEAR EDGE OF THE SIGN 20 FT. FROM THE TRAVEL LANE. ERECT ALL OTHER "D", "E", AND "F" SIGNS WITH THE NEAR EDGE OF THE SIGN AT THE EDGE OF THE SHOULDER BREAK (6 FT. MINIMUM CLEARANCE, 12 FT. DESIRABLE, FROM THE EDGE OF TRAVEL LANE), OR AS DIMENSIONED ON PLAN SHEETS.
  - ERECT TYPE "D", "E", AND "F" SIGNS WITH THE BOTTOM OF SIGN ASSEMBLY AT LEAST 7 FT. ABOVE THE EDGE OF THE TRAVEL LANE ON ROADS WITH 2 OR MORE LANES IN THE SAME DIRECTION AND AT LEAST 5 FT. ON OTHER ROUTES. THE VERTICAL CLEARANCE IS 7 FT. WHERE REQUIRED FOR PEDESTRIAN TRAFFIC AND/OR PARKED VEHICLES.
  - THE VERTICAL DIMENSION BETWEEN MOUNTING HOLE CENTERS ON ALL TYPES "D", "E", AND "F" SIGNS IS 30" MAXIMUM. THE VERTICAL AND HORIZONTAL DIMENSIONS BETWEEN MOUNTING HOLES IS TO THE WHOLE INCH. EACH SIGN PANEL HAS A MINIMUM OF 2 BOLTS PER SUPPORT.
  - ATTACH SIGN W/ 5/8" HEX HEAD BOLT, NYLON WASHER, SHIM, FLAT WASHER, LOCK WASHER, HEX NUT NO BUCKLING OF THE SIGN WILL BE PERMITTED. SEE ASSEMBLY DETAIL SHEET# 2 OF 904.50.
  - FURNISH AND INSTALL CROSS-BRACING AS SHOWN IN DETAIL. PAINT ENDS OF CROSS BRACES W/ APPROVED. ZINC PAINT
  - INSTALL POST AND CROSS-BRACING WITH THE WIDE SIDE OF THE FLANGE TOWARD THE BACK OF SIGN(S) FOR COMBINATION TYPE "D" AND "F" SIGNS.
  - THE SHIELD HEIGHTS IN THESE ASSEMBLIES CAN NOT BE LARGER THAN 24".
  - IF SIGN ASSEMBLIES REQUIRE MORE THAN TWO U-CHANNEL SUPPORTS, THE SUPPORTS SHALL BE PLACED A MINIMUM OF 4 FT. BETWEEN POSTS. NO MORE THAN TWO POSTS SHALL FALL WITHIN 7 FT. PATH, OR THE SIGN ASSEMBLY MUST BE PLACED BEHIND BARRIER PROTECTION.

STATE OF NORTH CAROLINA  
DEPT. OF TRANSPORTATION  
DIVISION OF HIGHWAYS  
RALEIGH, N.C.

6-21

ENGLISH DETAIL DRAWING FOR  
MOUNTING OF  
TYPE 'D', 'E' AND 'F' SIGNS  
ON 'U' CHANNEL POSTS

SHEET 1 OF 2  
904D50

REVISED SIGNING  
ROADWAY STANDARD DRAWING

REVISED ROADWAY  
STANDARD DRAWING

3/13/2023 2:16:77 PM NC DOT NC 111\U-4424\Traffic\Signing\CADD\Signing Layout Plans\Sheets\U-4424\_sgn\_SIGN-1A.dgn

6/8/2021 5:54:01 PM SAS\DU\Standards Group\Standards and Drawings\Drawings\2018 Standard Drawings\Division 9 Final\0904.50\_sgn\_sht01\_Uchannel post\_6-21.dgn User:dstokes



SIGN NUMBER: 301	BACKG COLOR: Green
TYPE: D	COPY COLOR: White
QUANTITY: 1	
SIGN WIDTH: 3'-6"	
HEIGHT: 2'-0"	
TOTAL AREA: 7.0 Sq.Ft.	
BORDER TYPE: FLUSH	
RECESS: 0"	
WIDTH: 0.75"	
RADII: 3"	
NO. Z BARS:	MAT'L: 0.125" (3.2 mm) ALUMINUM
LENGTH:	

DESIGN BY: EWB  
 CHECKED BY: RRH  
 PROJECT ID: U-4424  
 LOCATION:  
 Sep 28, 2022  
 DIV: 4

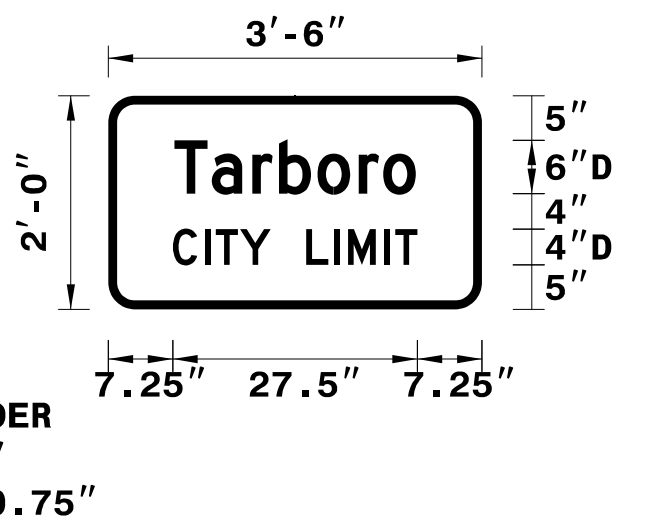

- USE NOTES:
1. Legend and border shall be direct applied Grade C sheeting.
  2. Background shall be Grade C reflective sheeting.

LETTER POSITIONS

Letter spacings are to start of next letter													Series/Size
													Text Length
T	a	r	b	o	r	o							D 2000
7.4	4.2	4.6	3	4.3	4.6	2.8	3.7	7.4					27.1
C	I	T	Y	L	I	M	I	T					D 2000
7.3	3.6	1.2	2.7	3.4	4	3.1	1.6	4.1	1.2	2.5	7.3	27.5	

FILENAME: U-4424\_sgn\_dsn

NORTH CAROLINA D.O.T. SIGN DETAIL

SIGN NUMBER: 404	BACKG COLOR: Yellow
TYPE: W42-7	COPY COLOR: Black
QUANTITY: 2	
SIGN WIDTH: 3'-0"	
HEIGHT: 3'-0"	
TOTAL AREA: 9.0 Sq.Ft.	
BORDER TYPE: FLUSH	
RECESS: 0.625"	
WIDTH: 0.875"	
RADII: 2.25"	
NO. Z BARS:	MAT'L: 0.080" (2.0 mm) ALUMINUM
LENGTH:	

DESIGN BY: EWB  
 CHECKED BY: RRH  
 PROJECT ID: U-4424  
 LOCATION:  
 Sep 28, 2022  
 DIV: 4

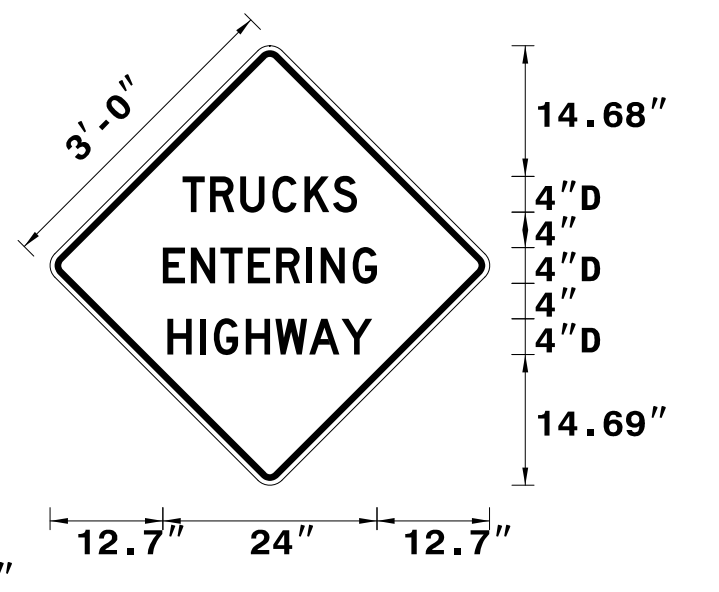

- USE NOTES:
1. Legend and border shall be direct applied Grade C sheeting.
  2. Background shall be Grade C reflective sheeting.

LETTER POSITIONS

Letter spacings are to start of next letter													Series/Size
													Text Length
T	R	U	C	K	S								D 2000
14.9	3.1	3.4	3.6	3.6	3.2	2.7	14.9						19.6
E	N	T	E	R	I	N	G						D 2000
12.7	3.2	3.3	3.1	3.2	3.4	1.6	3.6	2.7	12.7				24
H	I	G	H	W	A	Y							D 2000
13.2	3.7	1.5	3.6	3.3	3.8	3.6	3.4	13.2					23

FILENAME: U-4424\_sgn\_dsn

NORTH CAROLINA D.O.T. SIGN DETAIL

TIP NO. U-4424	SHEET NO. SIGN-2
APPROVED:	
DATE: 5/2/2023	
SEAL	

3/13/2023  
 2:18:57 PM  
 USER: 04421

# SIGN DESIGNS

APPROVED: *Eric W Bowman*  
DATE: 5/2/2023

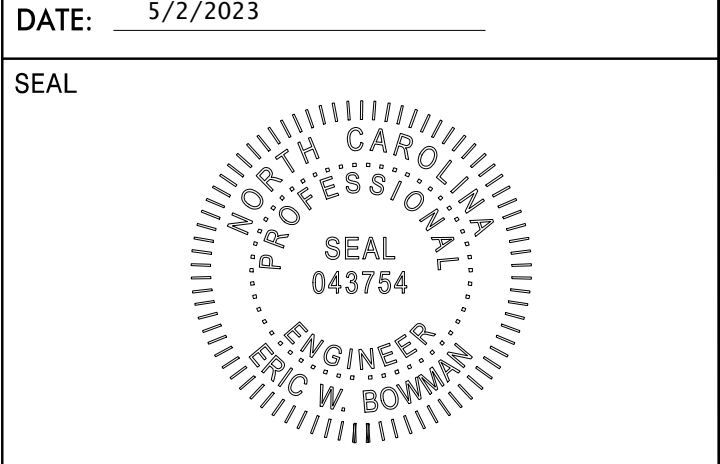

**DOCUMENT NOT CONSIDERED FINAL  
UNLESS ALL SIGNATURES COMPLETED**

401 QUANTITY REQ'D . 2

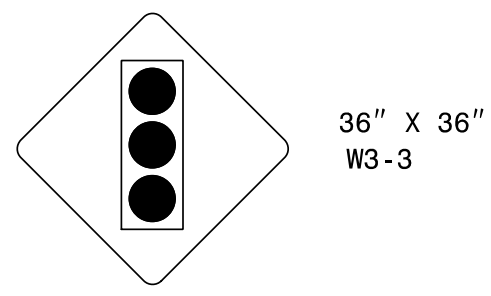

ONE "U" POSTS PER SIGN

406 QUANTITY REQ'D . 17

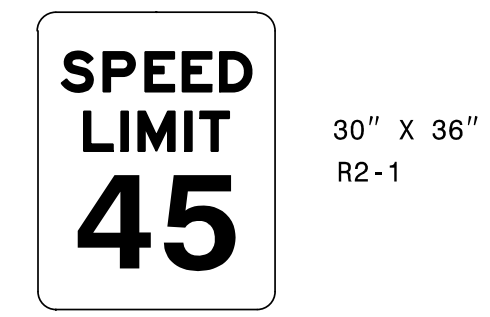

ONE "U" POST PER SIGN

411 QUANTITY REQ'D . 1

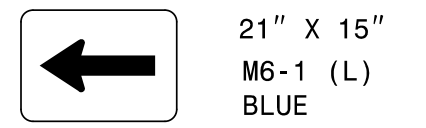

MOUNT UNDER SIGN 410

402 QUANTITY REQ'D . 11

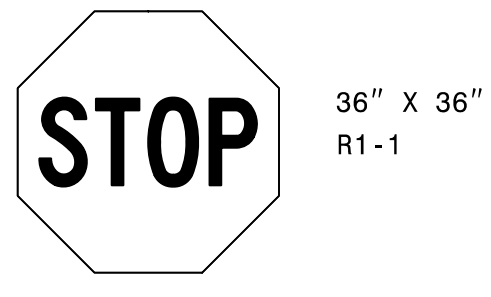

ONE "U" POST PER SIGN

407 QUANTITY REQ'D . 2

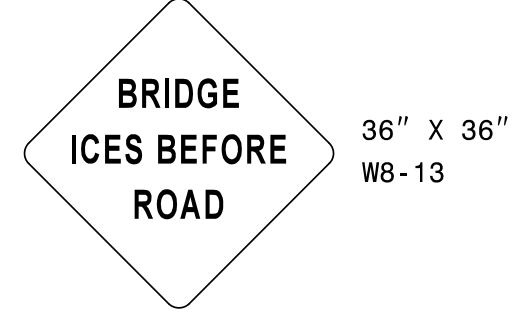

ONE "U" POST PER SIGN

412 QUANTITY REQ'D . 1

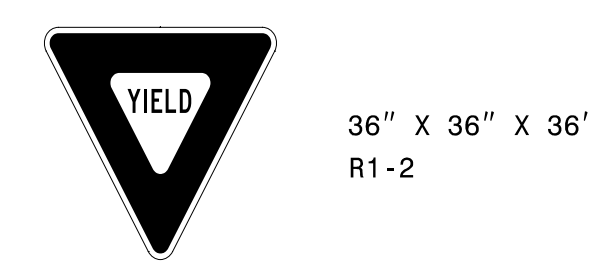

ONE "U" POST PER SIGN

403 QUANTITY REQ'D . 1

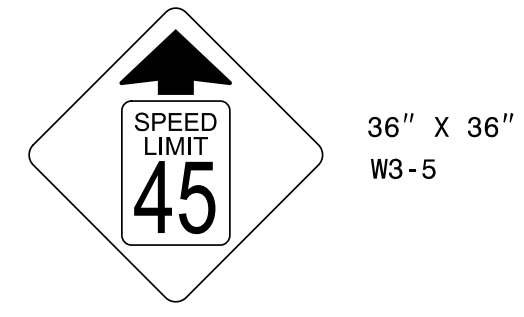

ONE "U" POST PER SIGN

408 QUANTITY REQ'D . 2

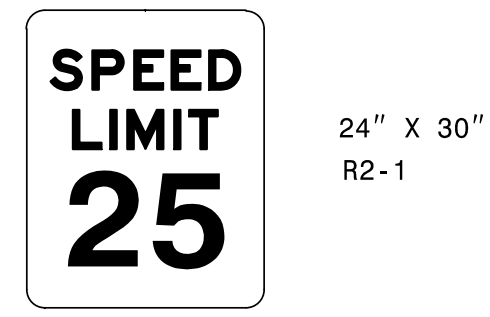

ONE "U" POST PER SIGN

404 QUANTITY REQ'D . 2



ONE "U" POST PER SIGN  
\*SEE SHEET SIGN-2 FOR SIGN DESIGN

409 QUANTITY REQ'D . 1

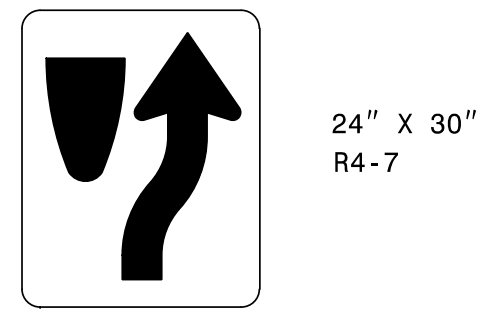

ONE "U" POST PER SIGN

405 QUANTITY REQ'D . 1

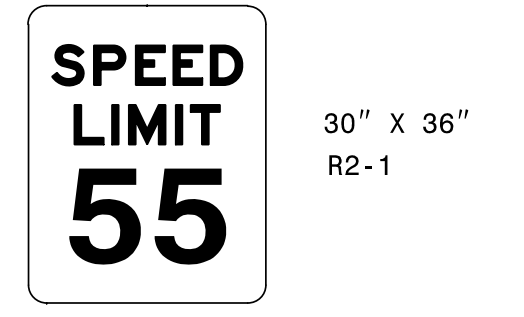

ONE "U" POST PER SIGN

410 QUANTITY REQ'D . 1

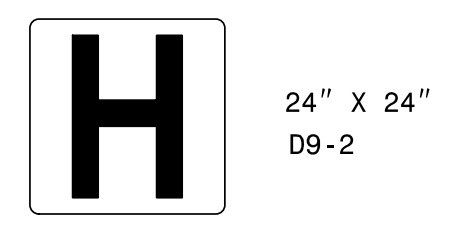

ONE "U" POST PER SIGN

**TYPE "E" SIGNS**

3/13/2023 2:18:07 PM C:\Users\106 NCDOT NC 111\U-4424\Traffic\Signing\CADD\Signing Layout Plans\Sheets\U-4424\_sgn-DEF\_Charts.dgn USE04421

APPROVED: *Eric W Bowman*  
DATE: 5/2/2023

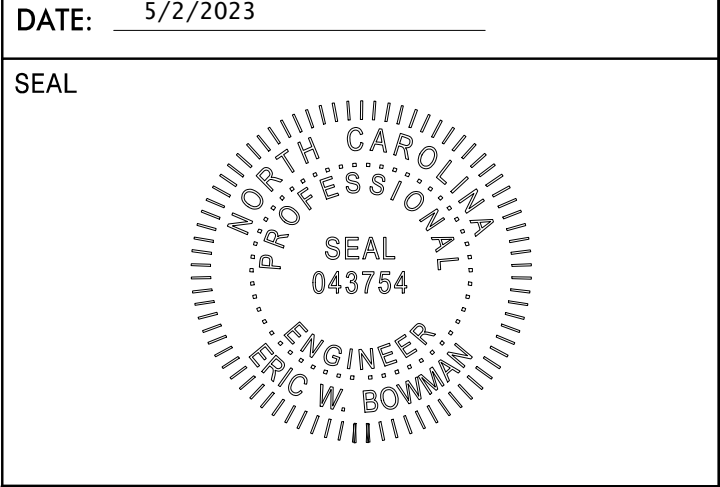

**DOCUMENT NOT CONSIDERED FINAL  
UNLESS ALL SIGNATURES COMPLETED**

501 QUANTITY REQ'D .1\_

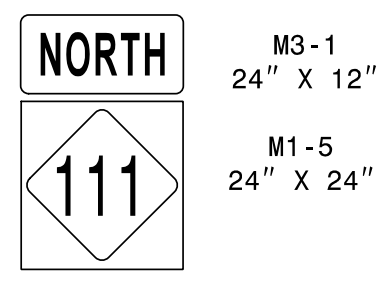

ONE "U" POST

506 QUANTITY REQ'D .1\_

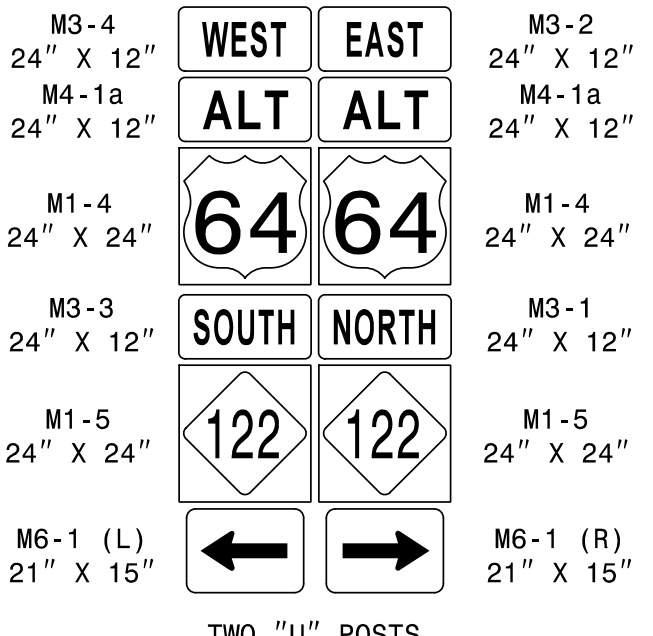

TWO "U" POSTS

502 QUANTITY REQ'D .1\_

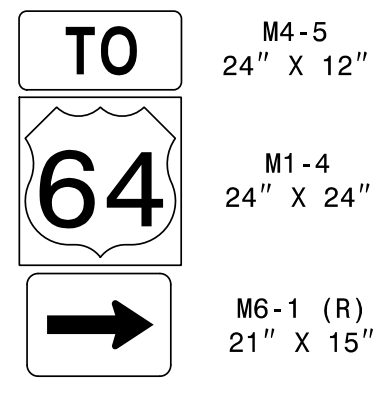

ONE "U" POST

507 QUANTITY REQ'D .1\_

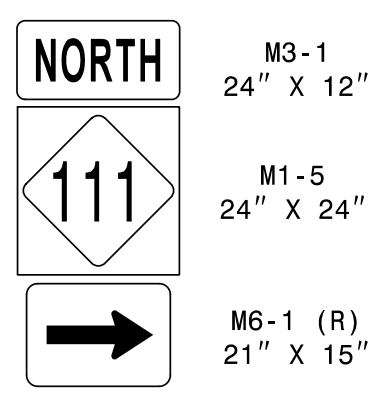

ONE "U" POST

503 QUANTITY REQ'D .1\_

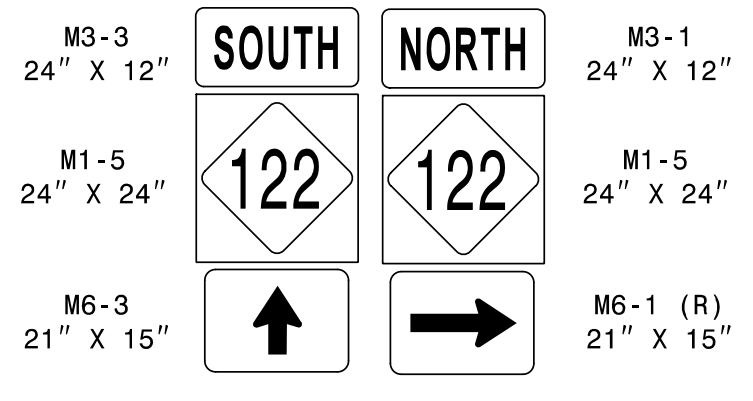

TWO "U" POSTS

508 QUANTITY REQ'D .1\_

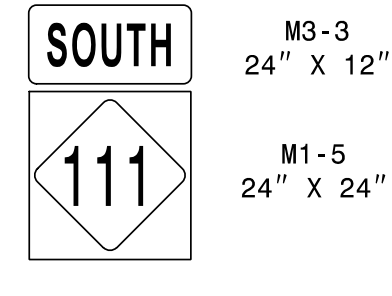

ONE "U" POST

504 QUANTITY REQ'D .1\_

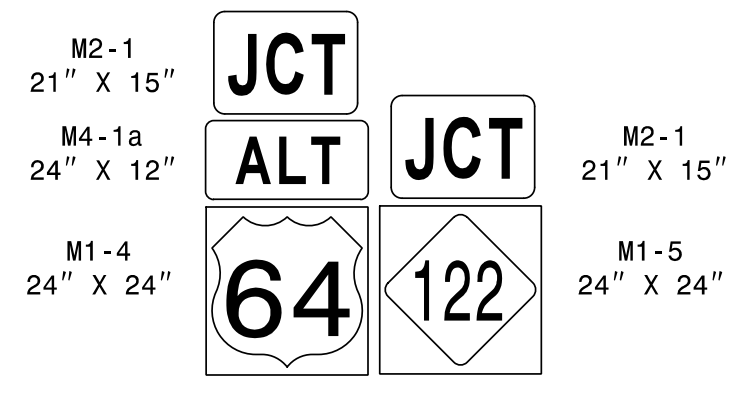

TWO "U" POSTS

509 QUANTITY REQ'D .1\_

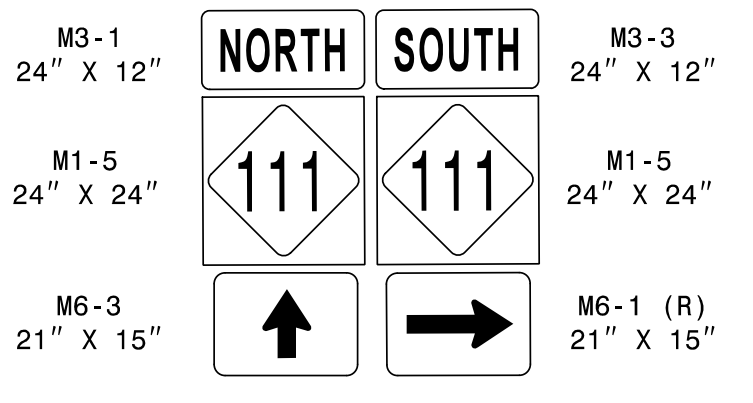

TWO "U" POSTS

505 QUANTITY REQ'D .1\_

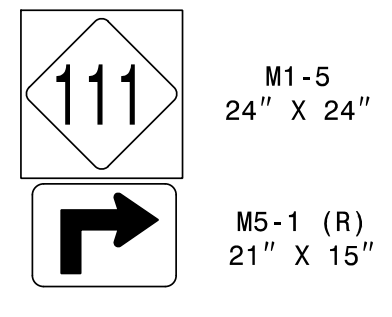

ONE "U" POST

**TYPE "F" SIGNS**

3/13/2023 2:18:07 PM C:\Users\106\OneDrive\Documents\Traffic\Signing\CADD\Signing\_Layout\Plans\Sheets\U-4424\_sgn\_DEF\_Charts.dgn USE04421

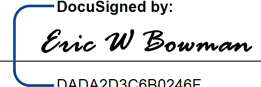
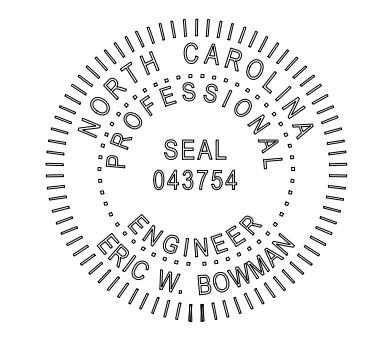
TIP NO. <b>U-4424</b>	SHEET NO. <b>SIGN-3</b>
APPROVED:  <small>DocuSigned by: Eric W. Bowman DADA2D3C680246F</small>	
DATE: 5/2/2023	
SEAL 	
<b>DOCUMENT NOT CONSIDERED FINAL UNLESS ALL SIGNATURES COMPLETED</b>	

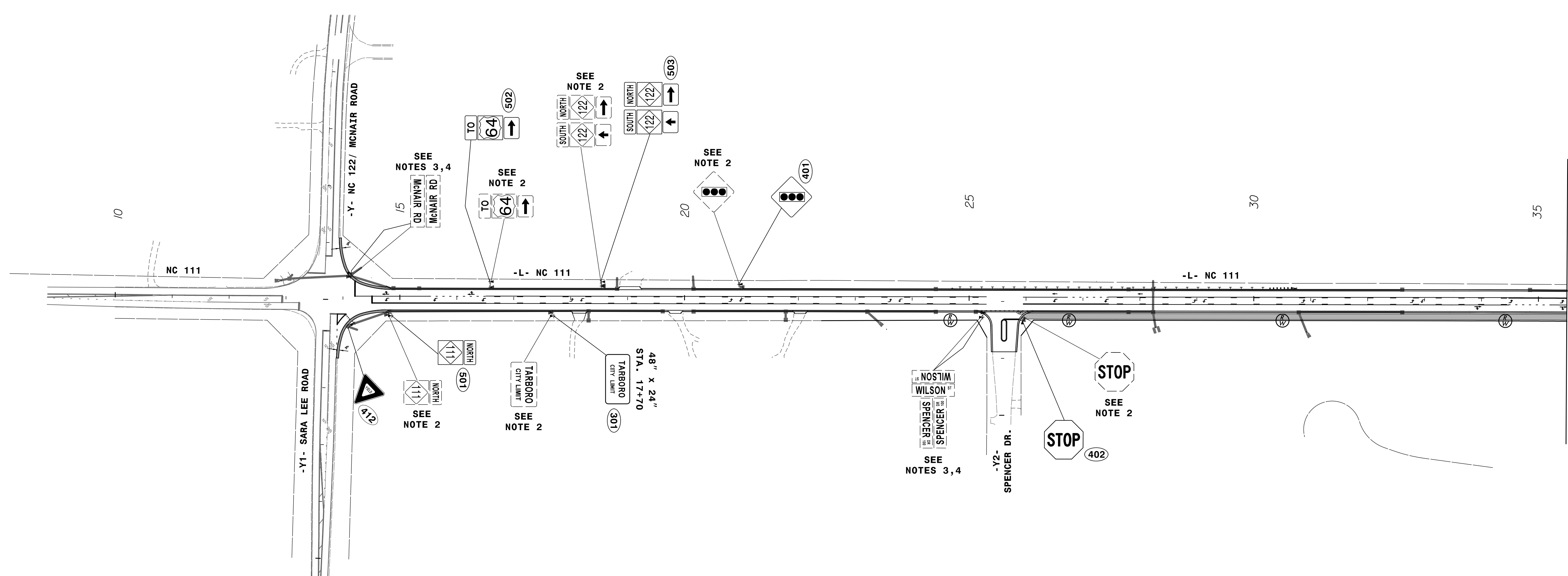
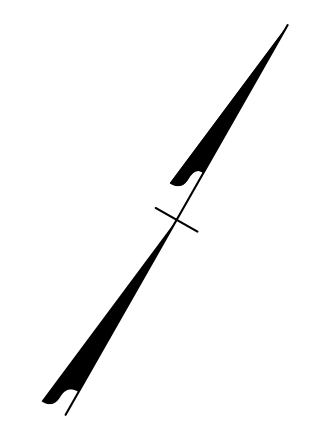

**MATCH LINE SEE SHEET SIGN-4  
-L- STA. 35+50.00**

3/13/2023 2:18:57 PM Z:\188771-06 NCDOT NC 111\U-4424\Traffic\Signing\CADD\Signing Layout Plans\Sheets\U-4424\_sgn\_psh\_03.dgn USE04421

# SIGNING PLANS

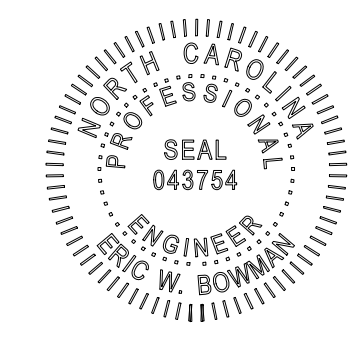

TIP NO. U-4424	SHEET NO. SIGN-4
APPROVED: <i>Eric W. Bowman</i> DADA2030580246F	
DATE: 5/2/2023	
SEAL	
	
DOCUMENT NOT CONSIDERED FINAL UNLESS ALL SIGNATURES COMPLETED	

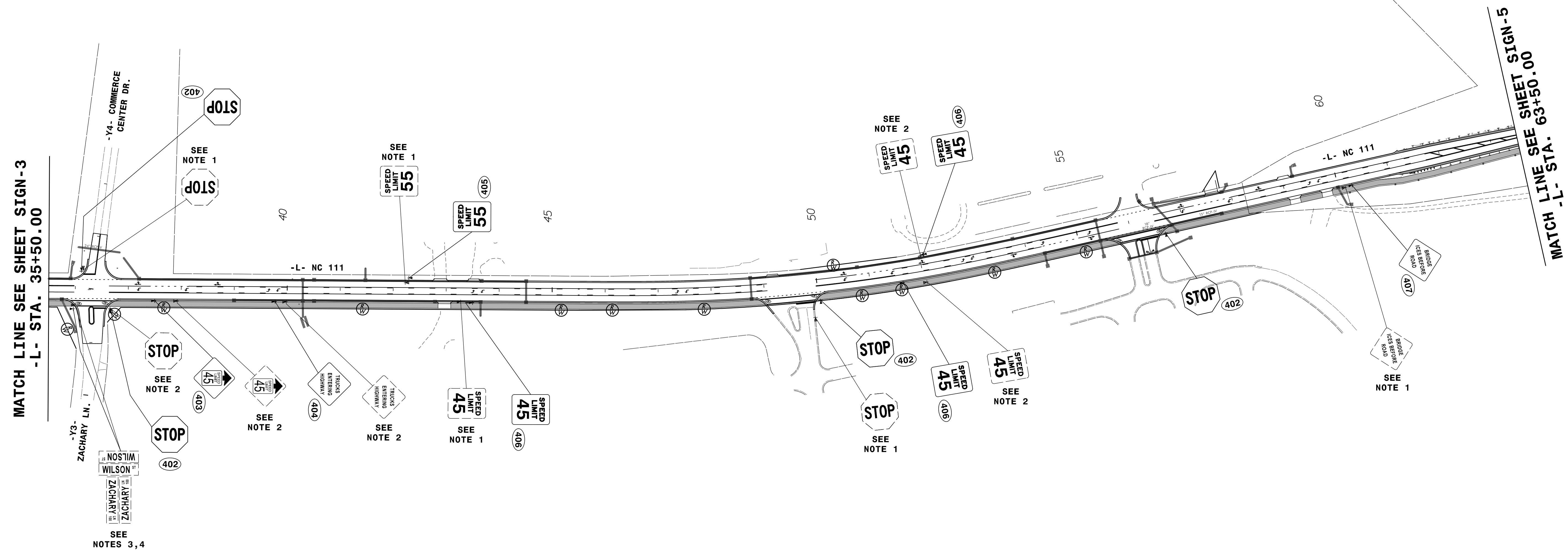
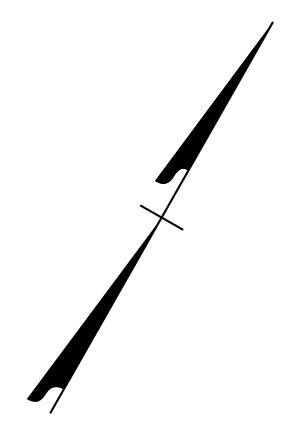

3/13/2023 2:18:07 PM  
 Z:\186771-06 NCDOT NC 111\U-4424\Traffic\Signing\CADD\Signing\_Layout\Plans\Sheets\U-4424\_sgn\_psh\_04.dgn  
 USE 04421

MATCH LINE SEE SHEET SIGN-3  
 -L- STA. 35+50.00

MATCH LINE SEE SHEET SIGN-5  
 -L- STA. 63+50.00

**SIGNING PLANS**

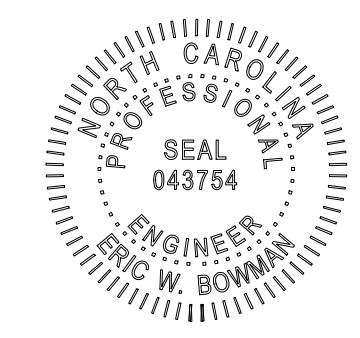

TIP NO. U-4424	SHEET NO. SIGN-5
APPROVED: <i>Eric W Bowman</i> <small>DADA2D3C680246F</small>	
DATE: 5/2/2023	
SEAL	
	
DOCUMENT NOT CONSIDERED FINAL UNLESS ALL SIGNATURES COMPLETED	

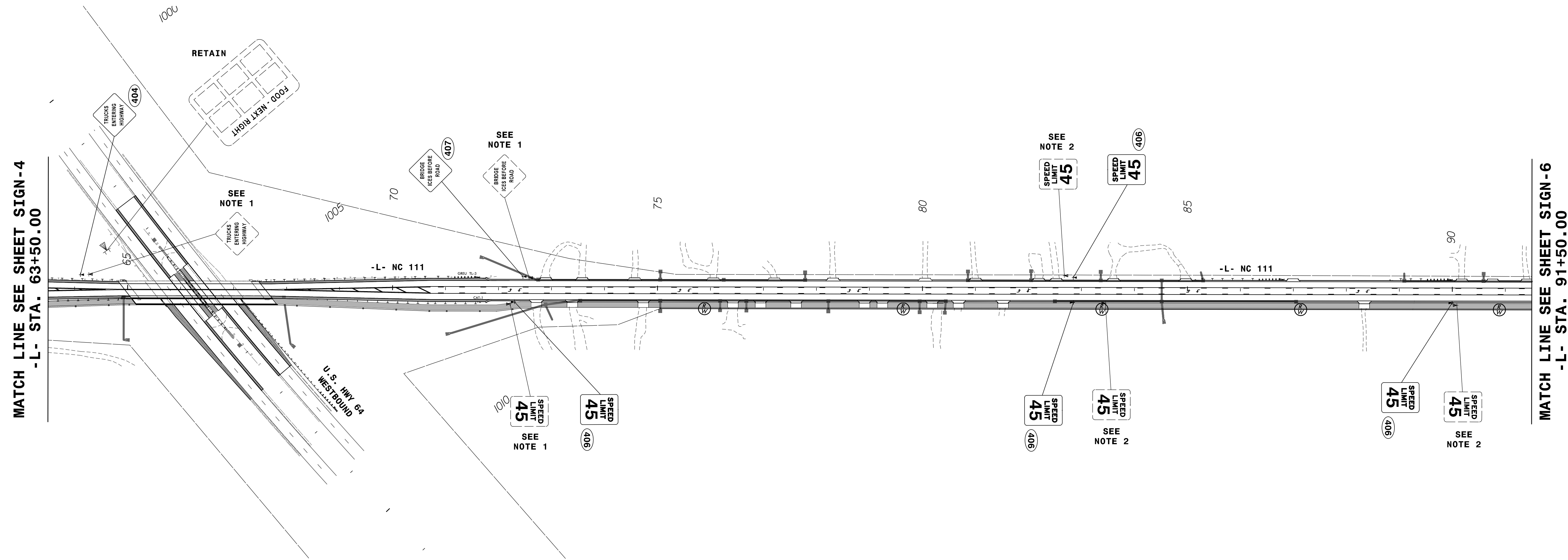
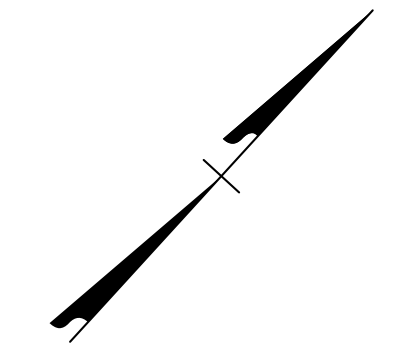

3/13/2023 2:16:57 PM  
 Z:\168771-06 NCDOT NC 111\U-4424\Traffic\Signing\CADD\Signing Layout Plans\Sheets\U-4424\_sgn\_psh\_05.dgn  
 USE 04421

# SIGNING PLANS

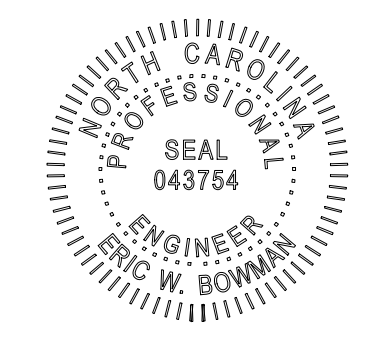
TIP NO. U-4424	SHEET NO. SIGN-6
APPROVED: <i>Eric W. Bowman</i> <small>DocuSigned by: Eric W. Bowman DADA2D33C6B0246F</small>	
DATE: 5/2/2023	
SEAL 	
DOCUMENT NOT CONSIDERED FINAL UNLESS ALL SIGNATURES COMPLETED	

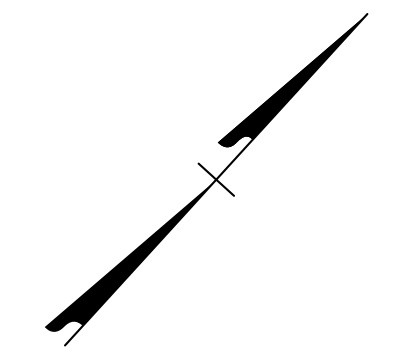

MATCH LINE SEE SHEET SIGN-5  
-L- STA. 91+50.00

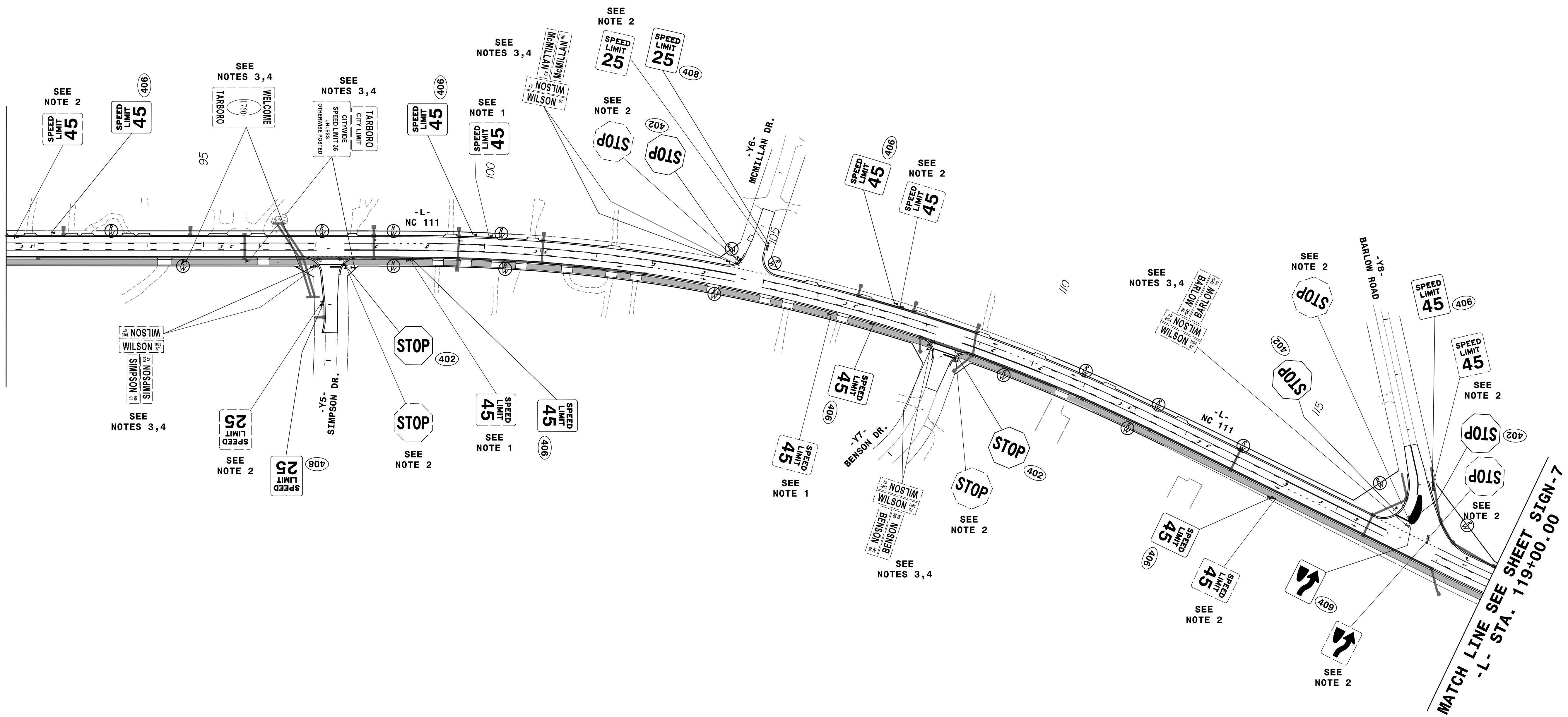

MATCH LINE SEE SHEET SIGN-7  
-L- STA. 119+00.00

3/13/2023 2:18:07 PM C:\Users\111\U-4424\Traffic\Signing\CADD\Signing Layout Plans\Sheets\U-4424\_sgn\_psh\_06.dgn  
USE04421

# SIGNING PLANS

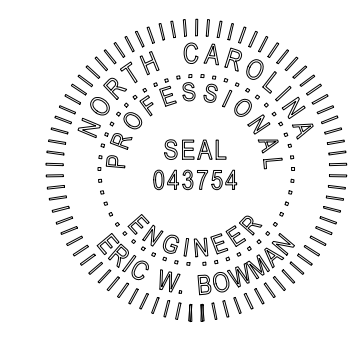

TIP NO. U-4424	SHEET NO. SIGN-7
APPROVED: <i>Eric W. Bowman</i> <small>DADA203C680246F</small>	
DATE: 5/2/2023	
SEAL	
	
DOCUMENT NOT CONSIDERED FINAL UNLESS ALL SIGNATURES COMPLETED	

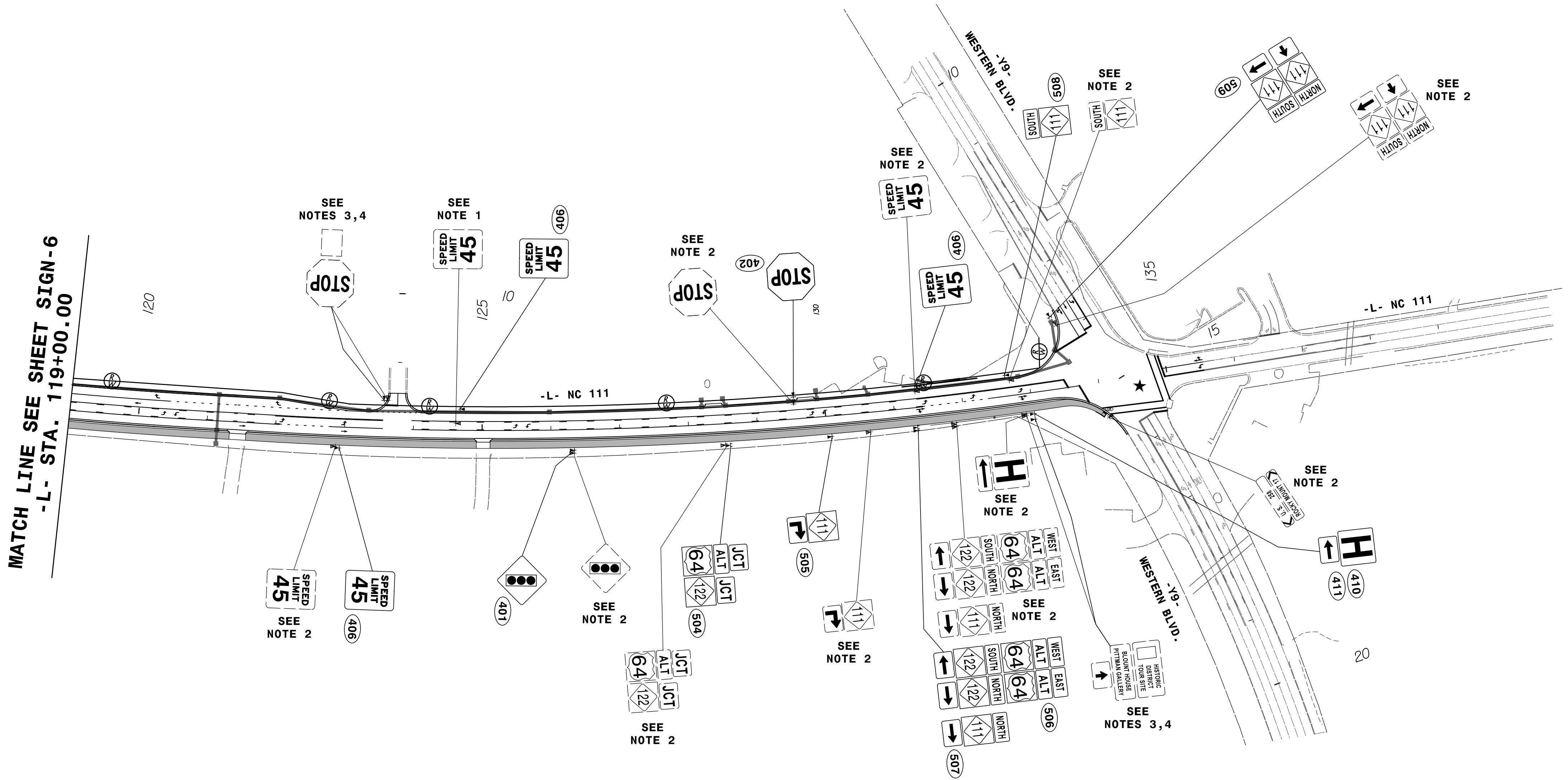
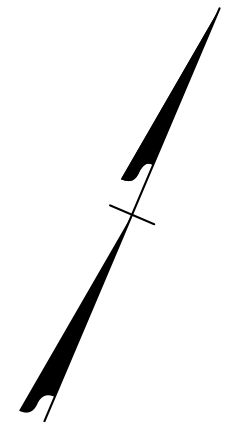

3/13/2023 2:18:57 PM C:\Users\106\NCDDOT\NC 111\U-4424\Traffic\Signing\CADD\Signing Layout\Plans\Sheets\U-4424\_sgn\_psh\_07.dgn  
 USER: 106

# SIGNING PLANS