

TIP NO.	SHEET NO.
U-4424	PMP-1
APPROVED: 	
DATE: 5/2/2023	
	
DOCUMENT NOT CONSIDERED FINAL UNLESS ALL SIGNATURES COMPLETED	

**STATE OF NORTH CAROLINA
DEPARTMENT OF TRANSPORTATION**

**PAVEMENT MARKING PLAN
EDGECOMBE COUNTY**

T.I.P.: U-4424

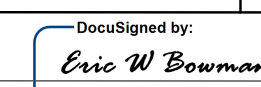
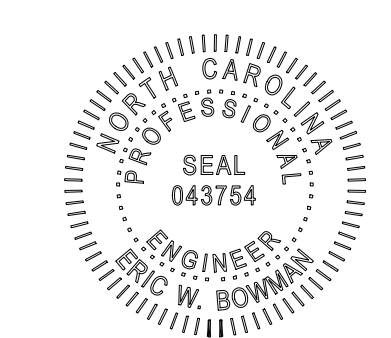
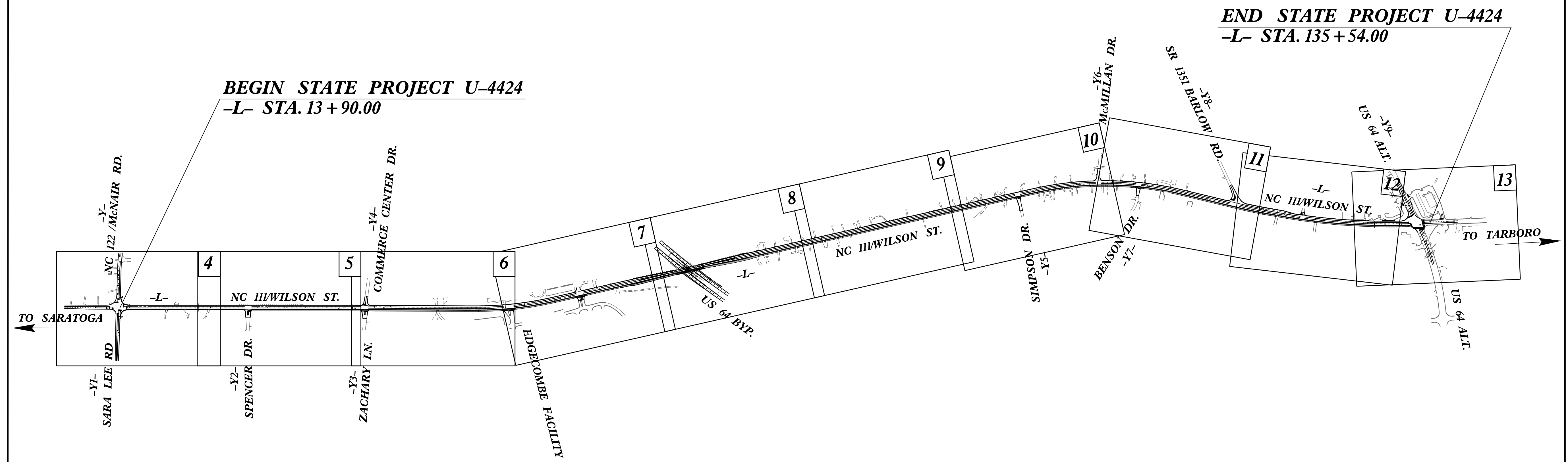
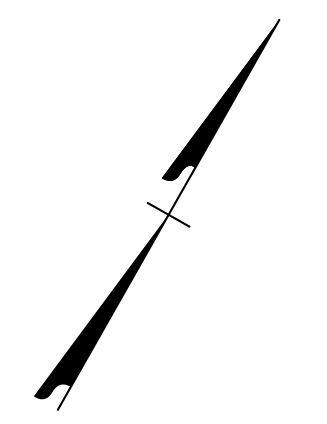
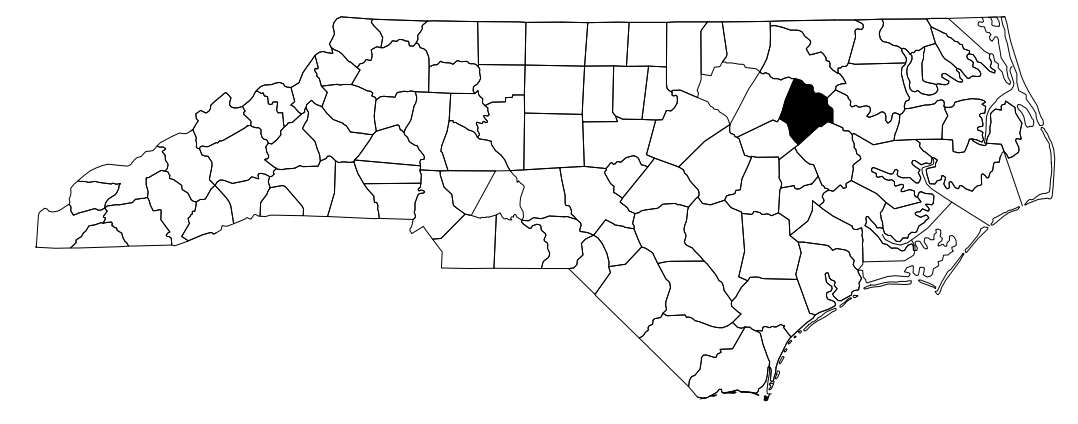

CONTRACT:

INDEX

SHEET NO.	DESCRIPTION
PMP-1	TITLE SHEET
PMP-2	ROADWAY STANDARD DRAWINGS & GENERAL NOTES
PMP-2A	REVISED PAVEMENT MARKING STANDARD
PMP-3	PAVEMENT MARKING SCHEDULE
PMP-4 THRU 13	PAVEMENT MARKING PLANS

PLAN SUBMITTED TO: N.C.D.O.T. SIGNING AND DELINEATION UNIT	
<u>AYMAN I. ALQUDWAH, PE</u>	SIGNING & DELINEATION REGIONAL ENGINEER
<u>MITCH EATON, PE</u>	SIGNING & DELINEATION PROJECT DESIGN ENGINEER

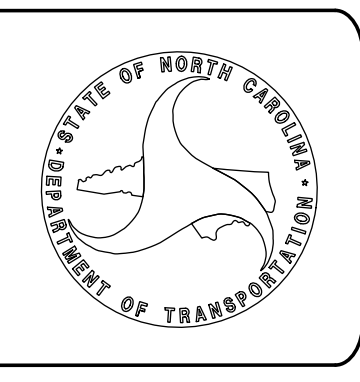



PLAN PREPARED BY: WSP	
<u>ERIC BOWMAN, PE</u>	PROJECT TRAFFIC ENGINEER
<u>SAYMA AFREEN</u>	PROJECT TRAFFIC DESIGN ENGINEER

wsp

1001 Morehead Square Dr., Suite 610,
Charlotte NC, 28203
NC LIC NO. F-0165

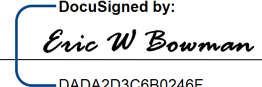
3/13/2023 06 NCDOT NC 111 U-4424 Traffic Pavement Markings U-4424-pmp.tsh.dgn
USL1864421

TIP NO.	SHEET NO.
U-4424	PMP-2
APPROVED:  <small>DocuSigned by: Eric W. Bowman DADA203C6B0246F</small>	
DATE: 5/2/2023	
SEAL	
	
DOCUMENT NOT CONSIDERED FINAL UNLESS ALL SIGNATURES COMPLETED	

ROADWAY STANDARD DRAWING

THE FOLLOWING ROADWAY STANDARDS AS APPEAR IN "ROADWAY STANDARD DRAWINGS" - PROJECT SERVICES UNIT - N.C. DEPARTMENT OF TRANSPORTATION - RALEIGH, N.C., DATED JANUARY 2018 ARE APPLICABLE TO THIS PROJECT AND BY REFERENCE HEREBY ARE CONSIDERED A PART OF THESE PLANS:

<u>STD. NO.</u>	<u>TITLE</u>
1205.01	PAVEMENT MARKINGS - LINE TYPES AND OFFSETS
1205.02	PAVEMENT MARKINGS - TWO-LANE AND MULTILANE ROADWAYS
1205.04	PAVEMENT MARKINGS - INTERSECTIONS (SHEET 1 OF 2)
1205.05	PAVEMENT MARKINGS - TURN LANES
1205.07	PAVEMENT MARKINGS - PEDESTRIAN CROSSWALKS
1205.08	PAVEMENT MARKINGS - SYMBOLS AND WORD MESSAGES
1205.09	PAVEMENT MARKINGS - PAINTED ISLANDS
1205.12	PAVEMENT MARKINGS - BRIDGES
1250.01	RAISED PAVEMENT MARKERS - INSTALLATION SPACING
1251.01	RAISED PAVEMENT MARKERS - PERMANENT AND TEMPORARY
1253.01	RAISED PAVEMENT MARKERS - SNOWPLOWABLE
1261.01	GUARDRAIL AND BARRIER DELINEATORS - INSTALLATION SPACING
1261.02	GUARDRAIL AND BARRIER DELINEATORS - TYPES AND MOUNTING
1262.01	GUARDRAIL END DELINEATION
1264.01	OBJECT MARKERS - TYPES
1264.02	OBJECT MARKERS - INSTALLATION

GENERAL NOTES

THE FOLLOWING GENERAL NOTES APPLY AT ALL TIMES FOR THE DURATION OF THE CONSTRUCTION PROJECT, EXCEPT WHEN OTHERWISE NOTED IN THE PLAN, OR DIRECTED BY THE ENGINEER.

- A) INSTALL PAVEMENT MARKINGS AND PAVEMENT MARKERS ON THE FINAL SURFACE AS FOLLOWS:

ROAD NAME	MARKING	MARKER
ALL	THERMOPLASTIC	SNOWPLOWABLE
CONCRETE BRIDGE DECK	POLYUREA	NONE

- B) TIE PROPOSED PAVEMENT MARKING LINES TO EXISTING PAVEMENT MARKING LINES.
- C) REMOVE/REPLACE ANY CONFLICTING/DAMAGED PAVEMENT MARKINGS AND MARKERS.
- D) PASSING ZONES WILL BE DETERMINED IN THE FIELD AND MUST BE APPROVED BY THE ENGINEER.
- E) STOP BAR LOCATION AT NON-SIGNALIZED INTERSECTIONS MAY BE ADJUSTED AS DIRECTED BY THE ENGINEER.
- F) REMOVE ALL RESIDUE AND SURFACE LAITANCE BY ACCEPTABLE METHODS ON CONCRETE BRIDGE DECKS PRIOR TO PLACING POLYUREA PAVEMENT MARKING MATERIAL.
- G) ON ASPHALT SURFACES UNLESS OTHERWISE SPECIFIED, HEATED-IN-PLACE THERMOPLASTIC MAY BE USED IN LIEU OF EXTRUDED THERMOPLASTIC FOR STOP BARS, SYMBOLS, CHARACTERS, CROSSWALKS AND DIAGONALS. IF HEATED-IN-PLACE IS USED, IT SHALL BE PAID FOR USING THE EXTRUDED THERMOPLASTIC PAY ITEM.
- H) SEE ROADWAY PLANS FOR ALTERNATE CURB RAMP DESIGNS WHEN INDICATED ON PAVEMENT MARKING DETAIL SHEETS.
- I) MARKERS ARE TO BE SPACED ACCORDING TO THE ROADWAY STANDARD DRAWINGS.

REVISED ROADWAY STANDARD DRAWINGS

THE FOLLOWING REVISED ROADWAY STANDARDS ARE USED ON THIS PROJECT:

<u>STD. NO.</u>	<u>TITLE</u>
1205D04	PAVEMENT MARKINGS - INTERSECTIONS (SHEET 2 OF 2) SEE SHEET PMP-2A



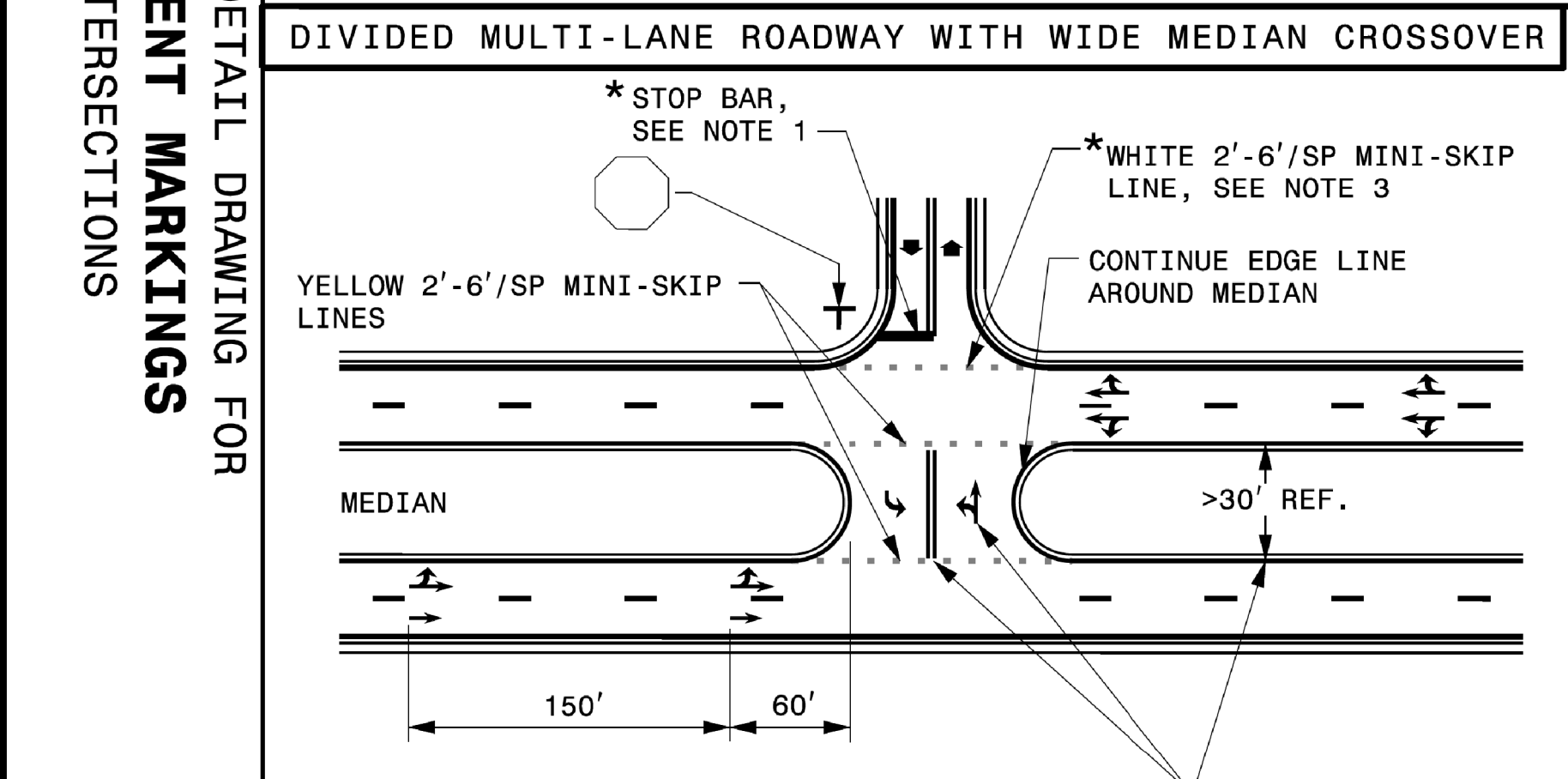
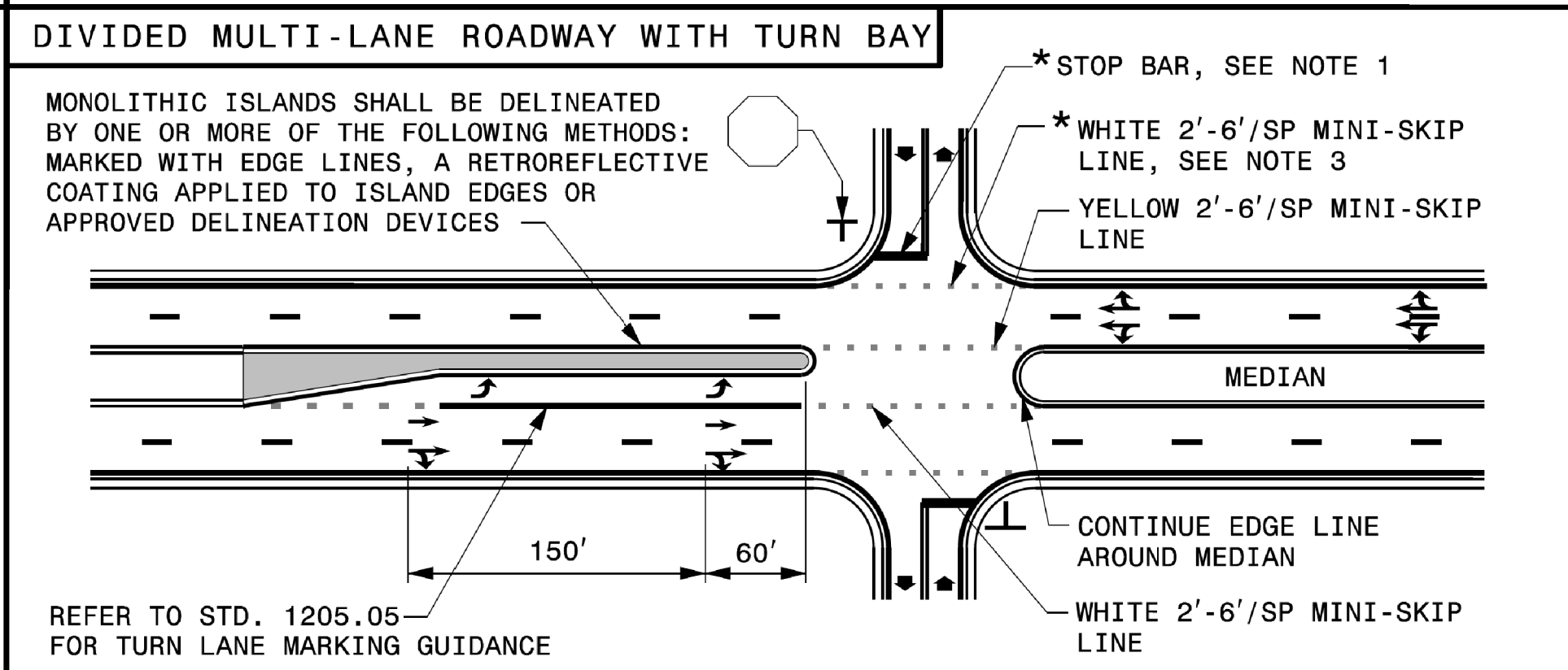
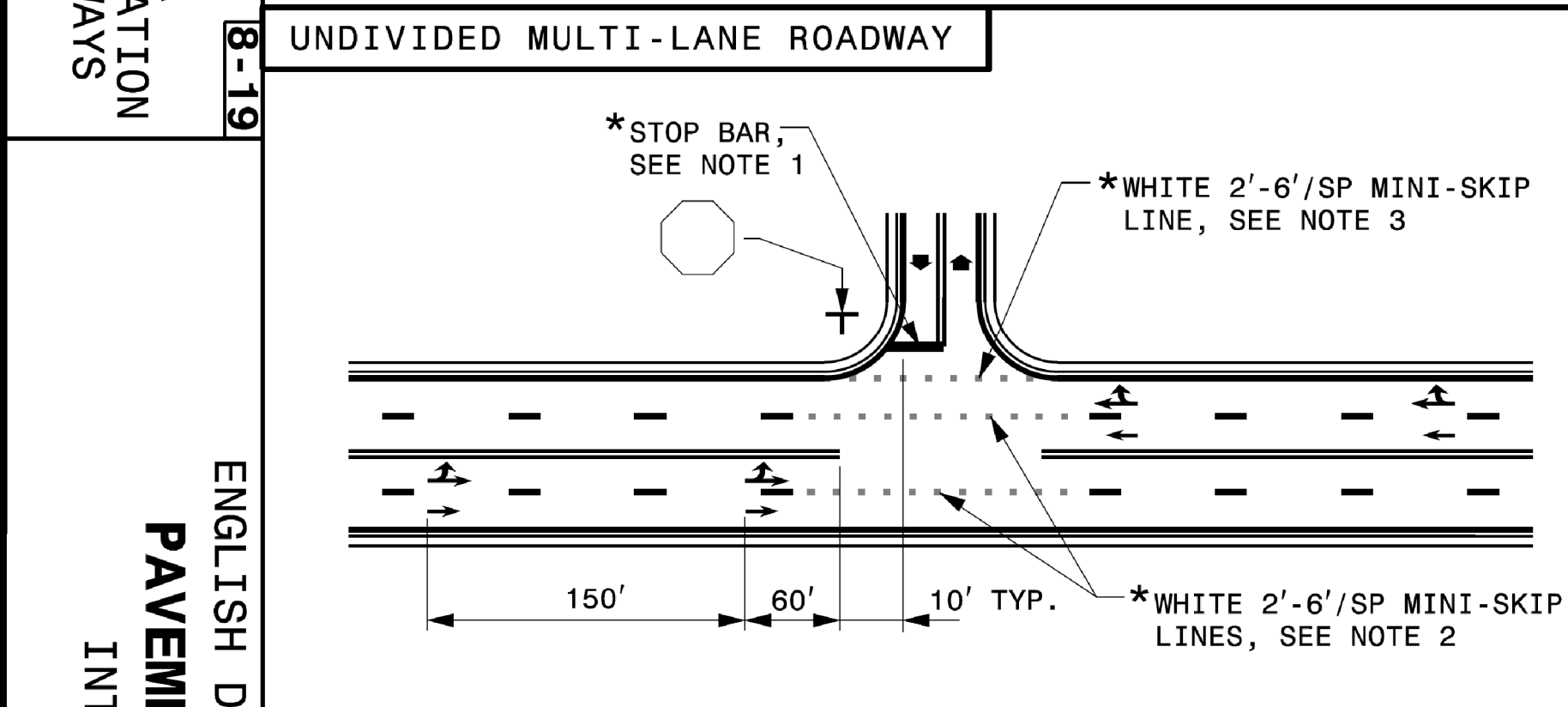
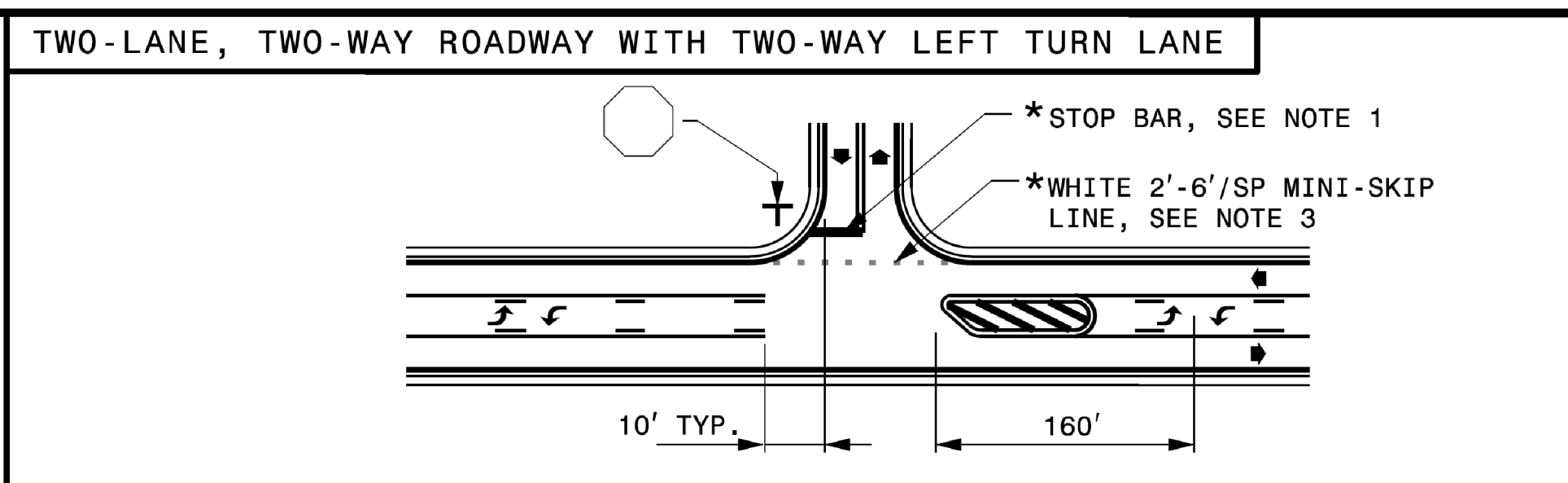
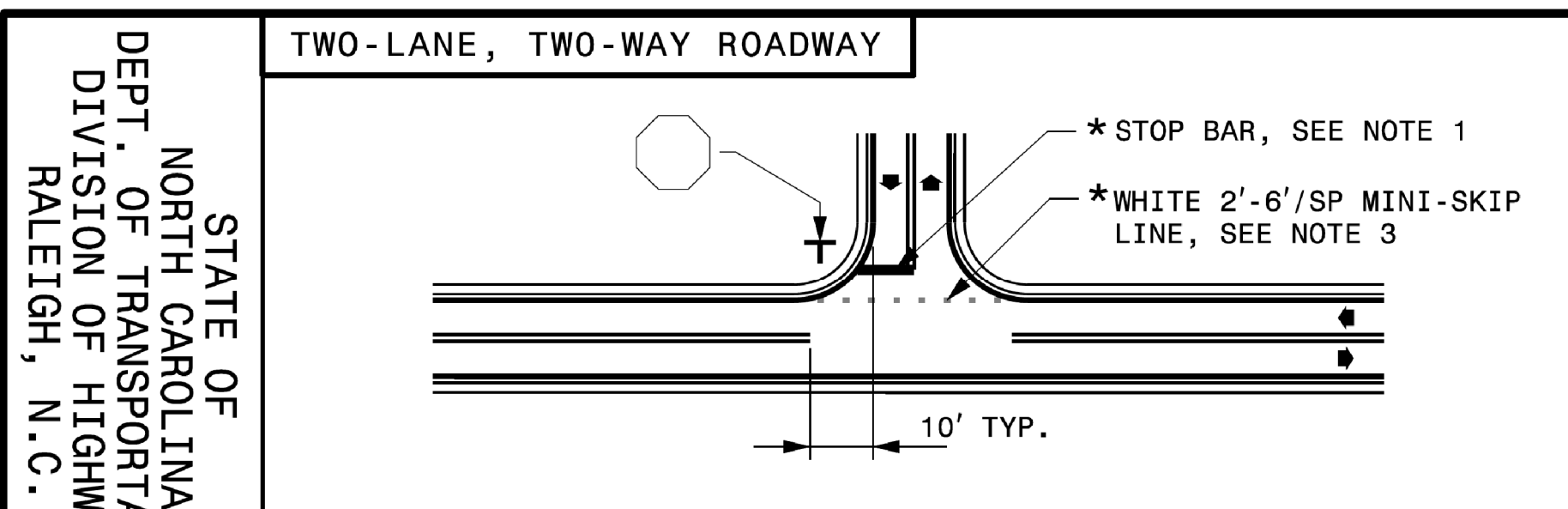

**ROADWAY STANDARD DRAWINGS
& GENERAL NOTES**

TIP NO.	SHEET NO.
DocuSigned by:	
<i>Matthew V. Springer</i>	
APPROVED:	8/13/2019
DATE:	6/20/2019 8:58:44 AM
SEAL	
	

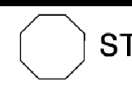

GENERAL NOTES:

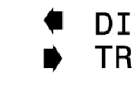
- 1- PLACEMENT OF STOP BARS AT NON-SIGNALIZED INTERSECTIONS IS OPTIONAL AND USED WHERE IT IS IMPORTANT TO INDICATE THE POINT WHICH VEHICLES ARE REQUIRED TO STOP. PLACE STOP BARS NO LESS THAN 4 FEET AND NO MORE THAN 30 FEET FROM THE NEAREST EDGE OF THE INTERSECTING ROADWAY. USE 10 FEET AS THE TYPICAL SETBACK DISTANCE OR AS DIRECTED BY THE ENGINEER.
- 2- MINI-SKIP LANE LINE EXTENSIONS SHOULD BE USED AT INTERSECTIONS THAT HAVE REDUCED VISIBILITY CONDITIONS SUCH AS OFFSET, SKEWED, OR CURVED ROADWAYS.
- 3- MINI-SKIP EDGE LINE EXTENSIONS MAY BE PLACED THROUGH INTERSECTIONS AND MAJOR DRIVEWAYS.
- 4- REFER TO ROADWAY STANDARD DRAWINGS 1205.01, 1205.02, 1205.05, 1205.08 AND 1205.09 FOR ADDITIONAL PAVEMENT MARKING GUIDANCE.

LEGEND	
	STOP SIGN
	STATIONARY SIGN
	DIRECTION OF TRAFFIC FLOW
	PAVEMENT MARKING SYMBOLS
*	OPTIONAL

USE DOUBLE YELLOW CENTER LINE AND ARROW SYMBOLS IN MEDIAN CROSSOVER WHEN WIDTH OF MEDIAN EXCEEDS 30 FT, OTHERWISE THEY ARE NOT REQUIRED.

SHEET 2 OF 2
1205D04



SHEET 2 OF 2
1205D04

REVISED PAVEMENT MARKING ROADWAY STANDARD DRAWING

REVISED PAVEMENT MARKING STANDARD

S:\1\1\Standards Group\Standards and Drawings\Drawings\2018 Standard Drawings\Division 12 Final\1205D04.08-13-19.dgn
 User:dstokes

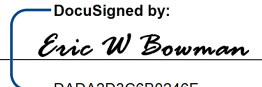
3/13/2023 2:16:07 PM U:\4424\Traffic\Pavement Markings\U-4424.pmp-ps-h-1A.dgn
 User:dstokes

TIP NO. U - 4424	SHEET NO. PMP - 3
APPROVED:  DADA20C8B024F...	
DATE: 5/2/2023	
SEAL 	
DOCUMENT NOT CONSIDERED FINAL UNLESS ALL SIGNATURES COMPLETED	

PAVEMENT MARKING SCHEDULE

TIP PROJECT # U-4424

<u>SYMBOL</u>	<u>DESCRIPTION</u>	<u>SYMBOL</u>	<u>DESCRIPTION</u>
	<u>THERMOPLASTIC (4", 90 MIL)</u>		<u>THERMOPLASTIC (24", 90 MIL)</u>
T1	WHITE EDGELINE	T61	WHITE STOP BAR
T2	WHITE SOLID LANE LINE		
T4	3 FT. - 9 FT./SP WHITE MINISKIP		<u>THERMOPLASTIC PAVEMENT MARKING SYMBOLS (90 MIL)</u>
T5	2 FT. - 6FT./SP WHITE MINISKIP		
T10	YELLOW EDGELINE	T70	LEFT TURN ARROW
T12	10 FT. YELLOW SKIP	T71	RIGHT TURN ARROW
T13	YELLOW DOUBLE CENTER	T72	STRAIGHT ARROW
		T74	COMBO. RIGHT /STRAIGHT ARROW
		T103	24" YIELD LINE TRIANGLE
	<u>THERMOPLASTIC (6", 90 MIL)</u>		
T20	WHITE EDGELINE		
T30	YELLOW EDGELINE		<u>POLYUREA (4", 30 MIL)</u>
		W1	WHITE EDGELINE
		W13	YELLOW DOUBLE CENTER
	<u>THERMOPLASTIC (8", 90 MIL)</u>		
T40	WHITE GORELINE		
T46	WHITE CROSSWALK LINE		
	<u>THERMOPLASTIC (12", 90 MIL)</u>		
T52	YELLOW DIAGONAL		

3/13/2023 2:16:07 PM C:\Users\user\Documents\Traffic\Pavement Markings\U-4424\pmp-ps-h-1A.dgn
 USEB04421

PAVEMENT MARKING SCHEDULE

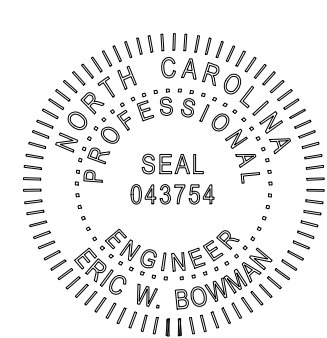
TIP NO. U-4424	SHEET NO. PMP-4
APPROVED: <i>Eric W. Bowman</i> DATE: 5/2/2023	
SEAL 	
DOCUMENT NOT CONSIDERED FINAL UNLESS ALL SIGNATURES COMPLETED	

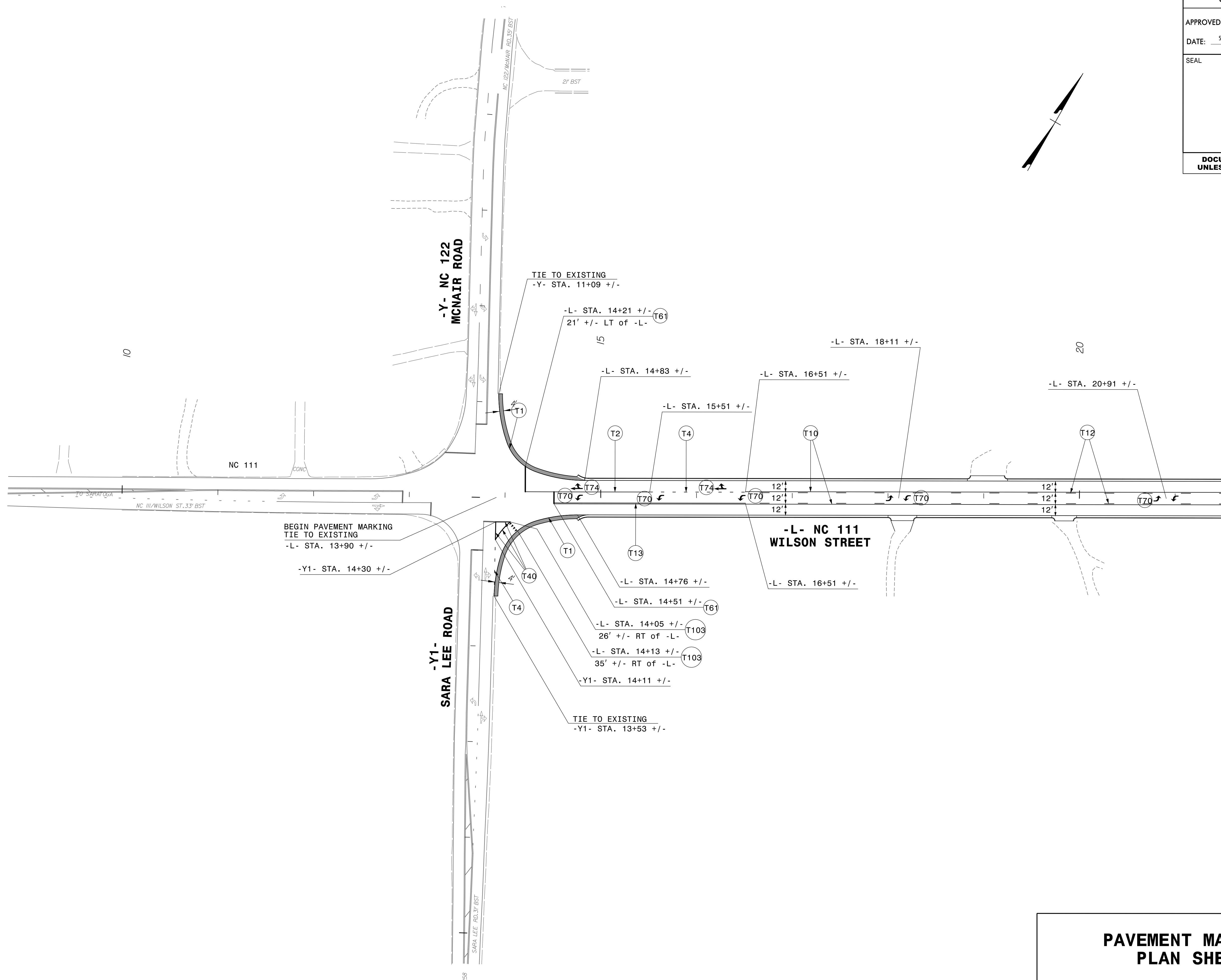

MATCH LINE SEE SHEET PMP-5
-L- STA. 21+50.00

**PAVEMENT MARKING
PLAN SHEET**

3/13/2023
Z:\188771-06 NCDOT NC III\U-4424\Traffic\Pavement Markings\U-4424_pmp_psh_04.dgn
USEB0442

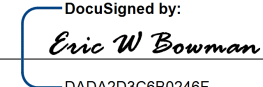
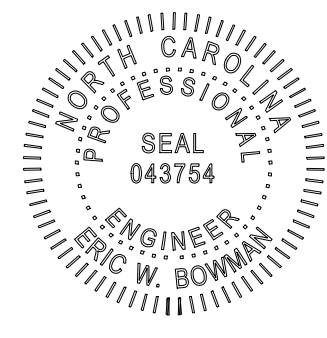
TIP NO. U-4424	SHEET NO. PMP-5
APPROVED:  Eric W. Bowman DADA2D3C8B0246F...	
DATE: 5/2/2023	
SEAL 	
DOCUMENT NOT CONSIDERED FINAL UNLESS ALL SIGNATURES COMPLETED	

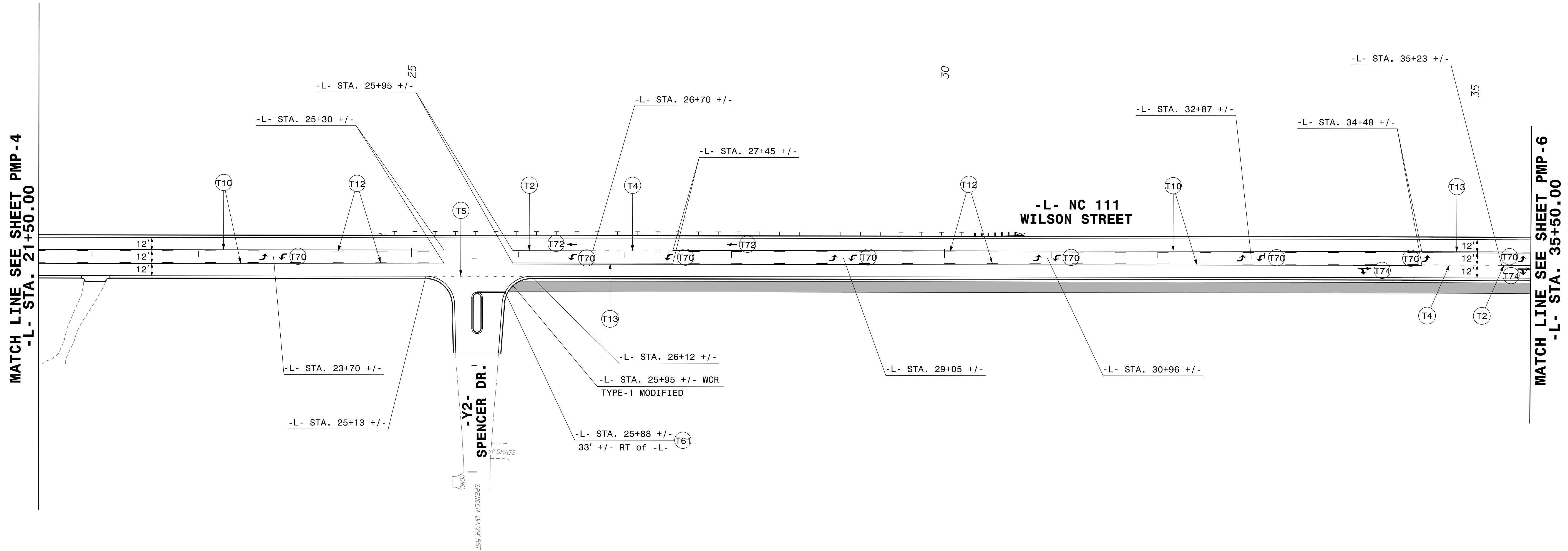
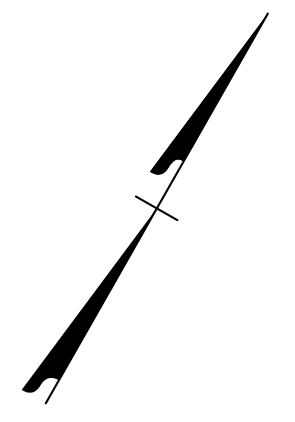

MATCH LINE SEE SHEET PMP-4
-L- STA. 21+50.00

MATCH LINE SEE SHEET PMP-6
-L- STA. 35+50.00

3/13/2023
Z:\188771-06 NCDOT NC III\U-4424\Traffic\Pavement Markings\U-4424_pmp_psh_05.dgn
USEB04421

**PAVEMENT MARKING
PLAN SHEET**

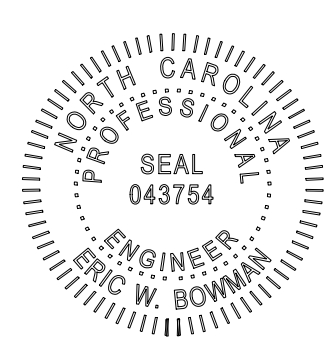
TIP NO. U-4424	SHEET NO. PMP-6
Decaligned by: APPROVED: <i>Eric W Bowman</i> <small>DADA203C8B024EF</small>	
DATE: 5/2/2023	
SEAL 	
DOCUMENT NOT CONSIDERED FINAL UNLESS ALL SIGNATURES COMPLETED	

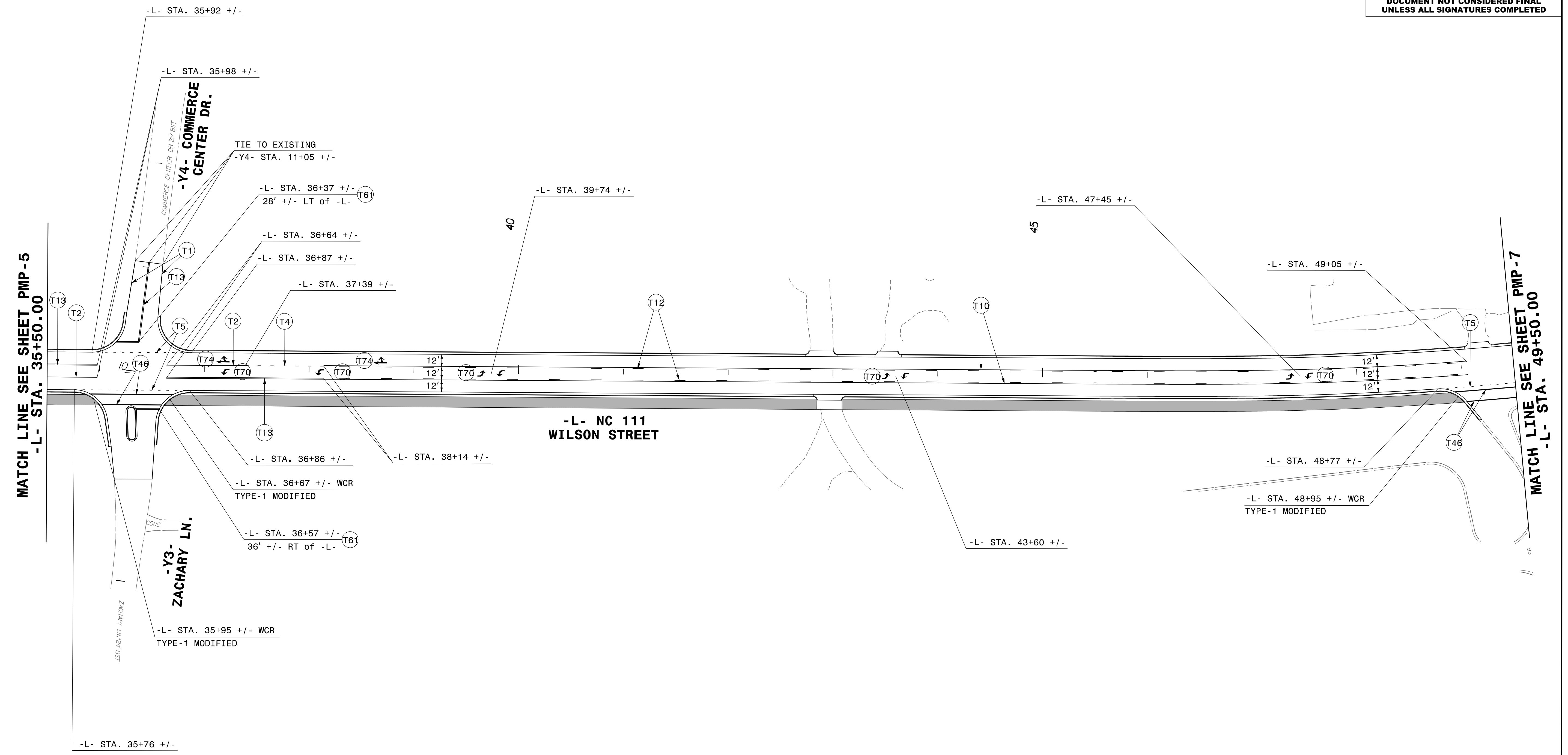
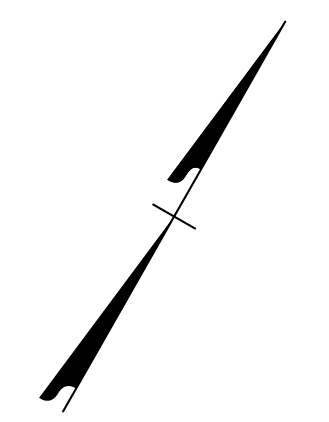

MATCH LINE SEE SHEET PMP-5
-L- STA. 35+50.00

MATCH LINE SEE SHEET PMP-7
-L- STA. 49+50.00

3/13/2023
 Z:\188771-06 NCDOT NC III\U-4424\Traffic\Pavement Markings\U-4424_pmp_psh_06.dgn
 USEB04421

**PAVEMENT MARKING
PLAN SHEET**

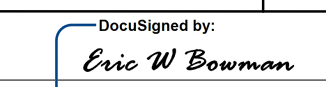
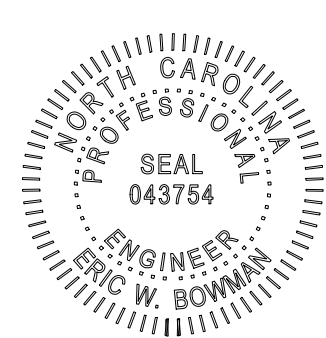
TIP NO. U-4424	SHEET NO. PMP-7
APPROVED:  Eric W. Bowman DADA2D3C8B0246F	
DATE: 5/2/2023	
SEAL 	
DOCUMENT NOT CONSIDERED FINAL UNLESS ALL SIGNATURES COMPLETED	

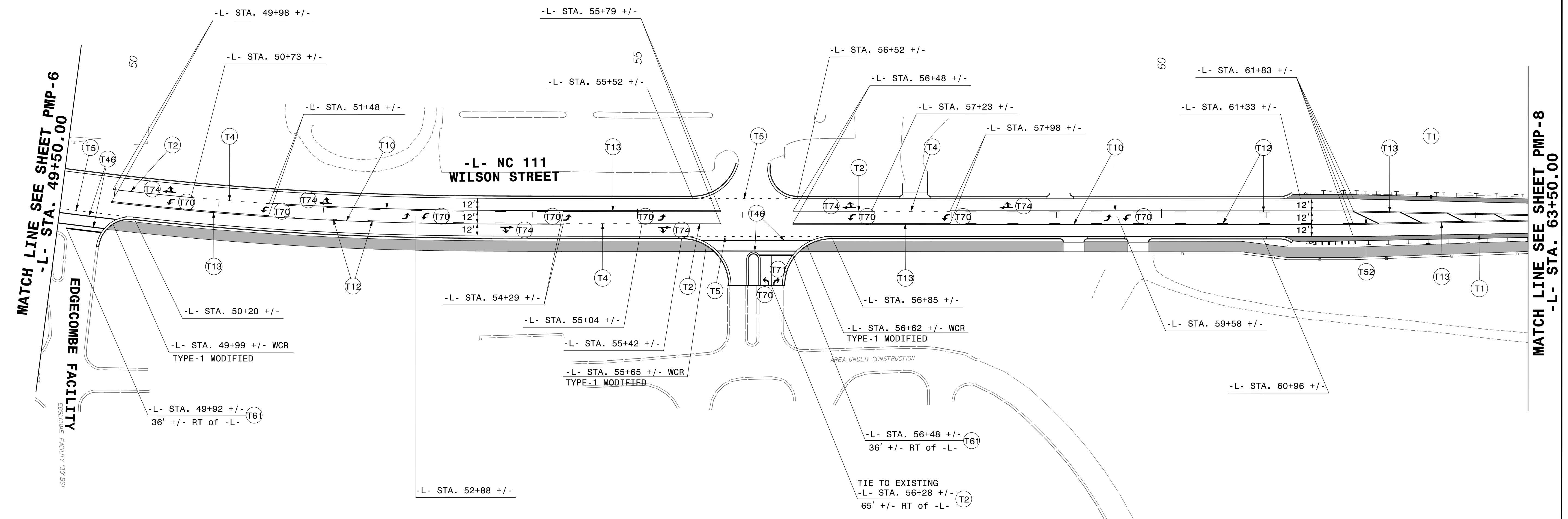
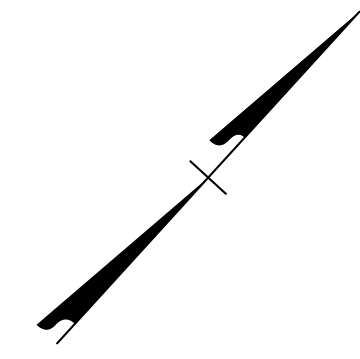

3/13/2023
Z:\188771-06 NCDOT NC III\U-4424\Traffic\Pavement Markings\U-4424_pmp_psh_07.dgn
USEB04421

**PAVEMENT MARKING
PLAN SHEET**

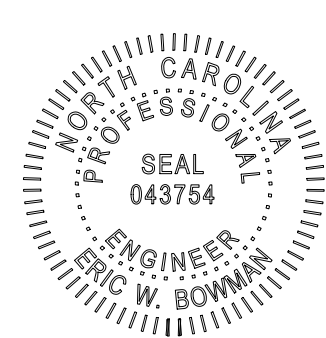
TIP NO. U-4424	SHEET NO. PMP-8
APPROVED:  Eric W. Bowman DADA2D3CB9246F...	
DATE: 5/2/2023	
SEAL 	
DOCUMENT NOT CONSIDERED FINAL UNLESS ALL SIGNATURES COMPLETED	

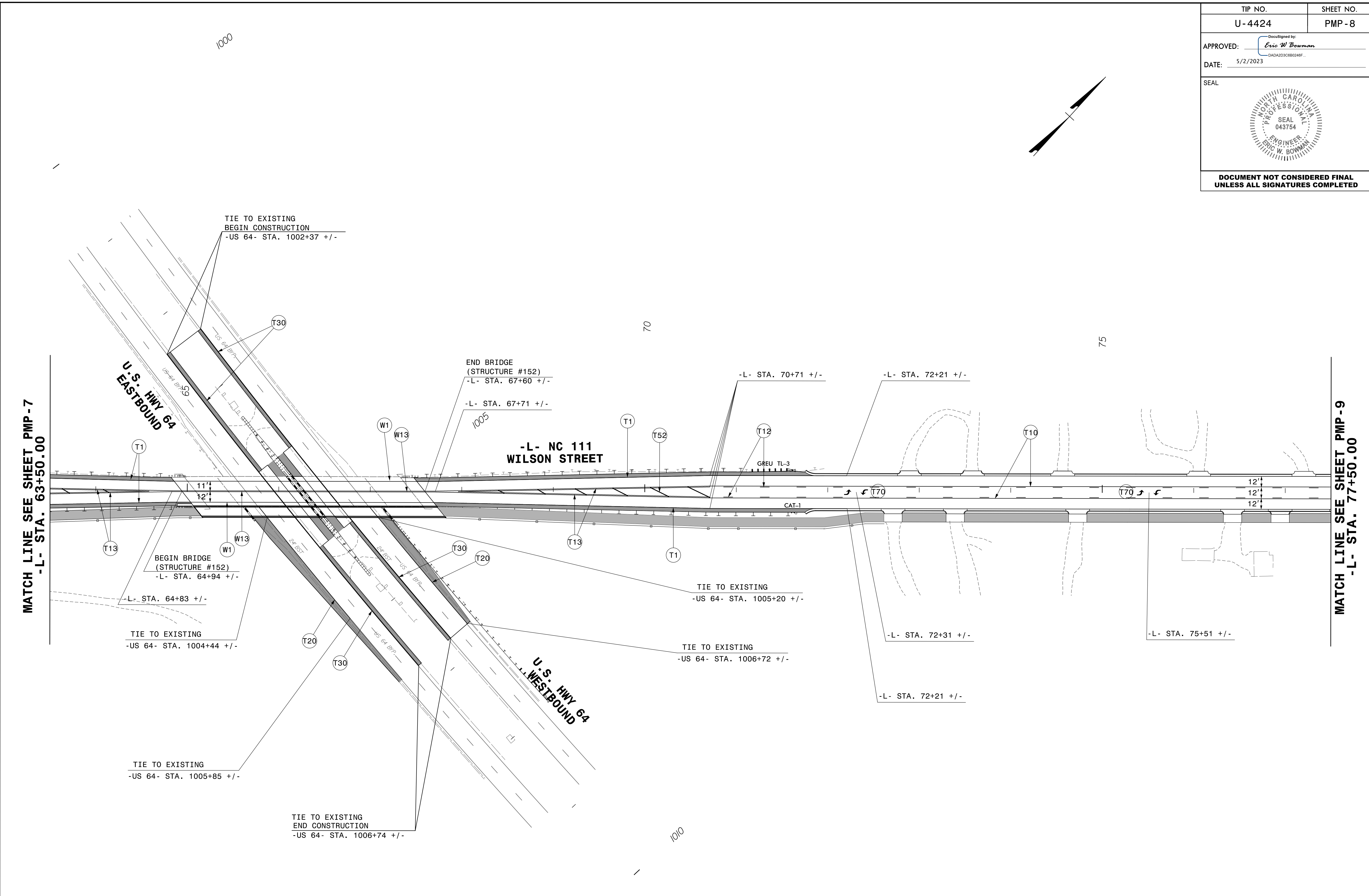

3/13/2023
 Z:\188771-06 NCDOT NC III\U-4424\Traffic\Pavement Markings\U-4424_pmp_psh_08.dgn
 USEB04421

**PAVEMENT MARKING
PLAN SHEET**

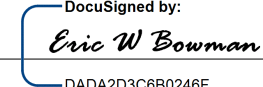
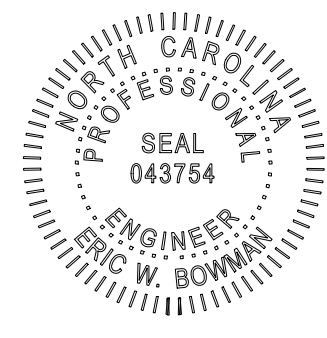
TIP NO. U-4424	SHEET NO. PMP-9
APPROVED:  DATE: 5/2/2023	
SEAL 	
DOCUMENT NOT CONSIDERED FINAL UNLESS ALL SIGNATURES COMPLETED	

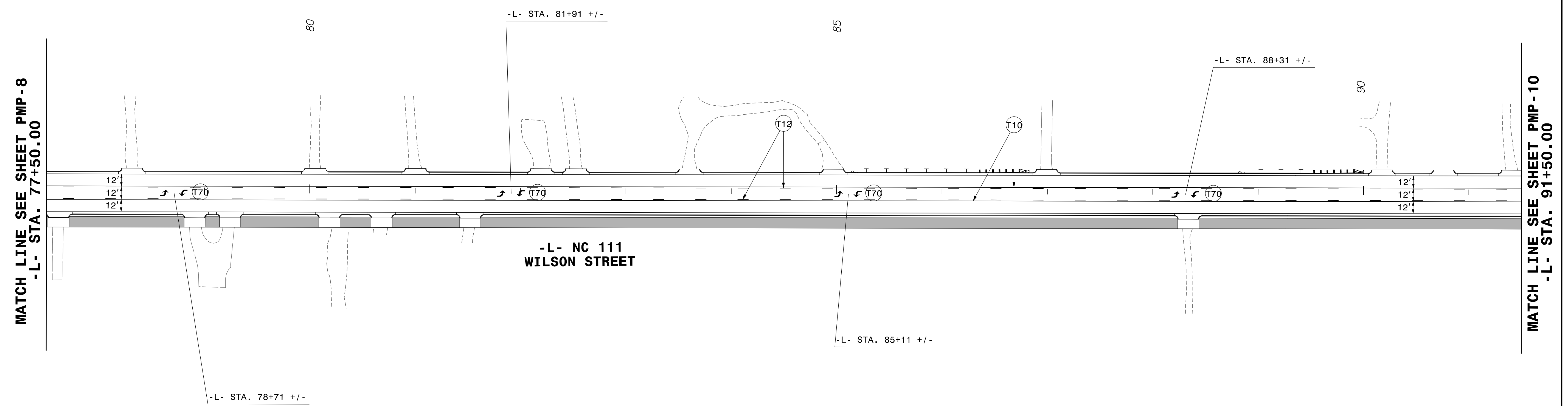
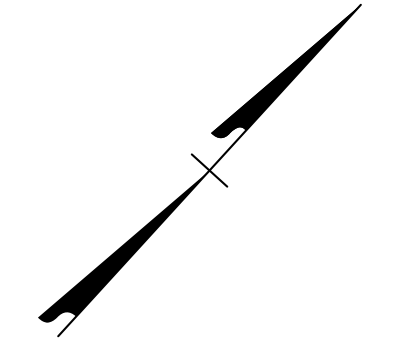

3/13/2023
Z:\188771-06 NCDOT NC III\U-4424\Traffic\Pavement Markings\U-4424_pmp_psh_09.dgn
USEB04421

**PAVEMENT MARKING
PLAN SHEET**

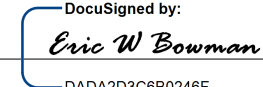
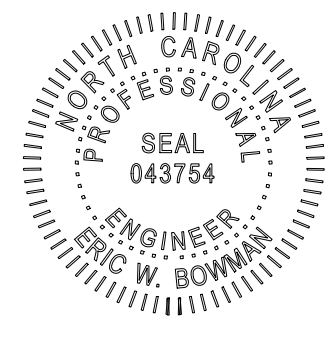
TIP NO. U-4424	SHEET NO. PMP-10
APPROVED:  Eric W. Bowman DADA2D3CB08046F	
DATE: 5/2/2023	
SEAL 	
DOCUMENT NOT CONSIDERED FINAL UNLESS ALL SIGNATURES COMPLETED	

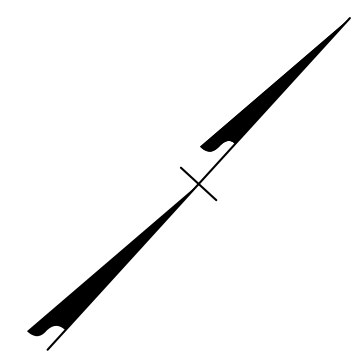

MATCH LINE SEE SHEET PMP-9
-L- STA. 91+50.00

MATCH LINE SEE SHEET PMP-11
-L- STA. 105+50.00

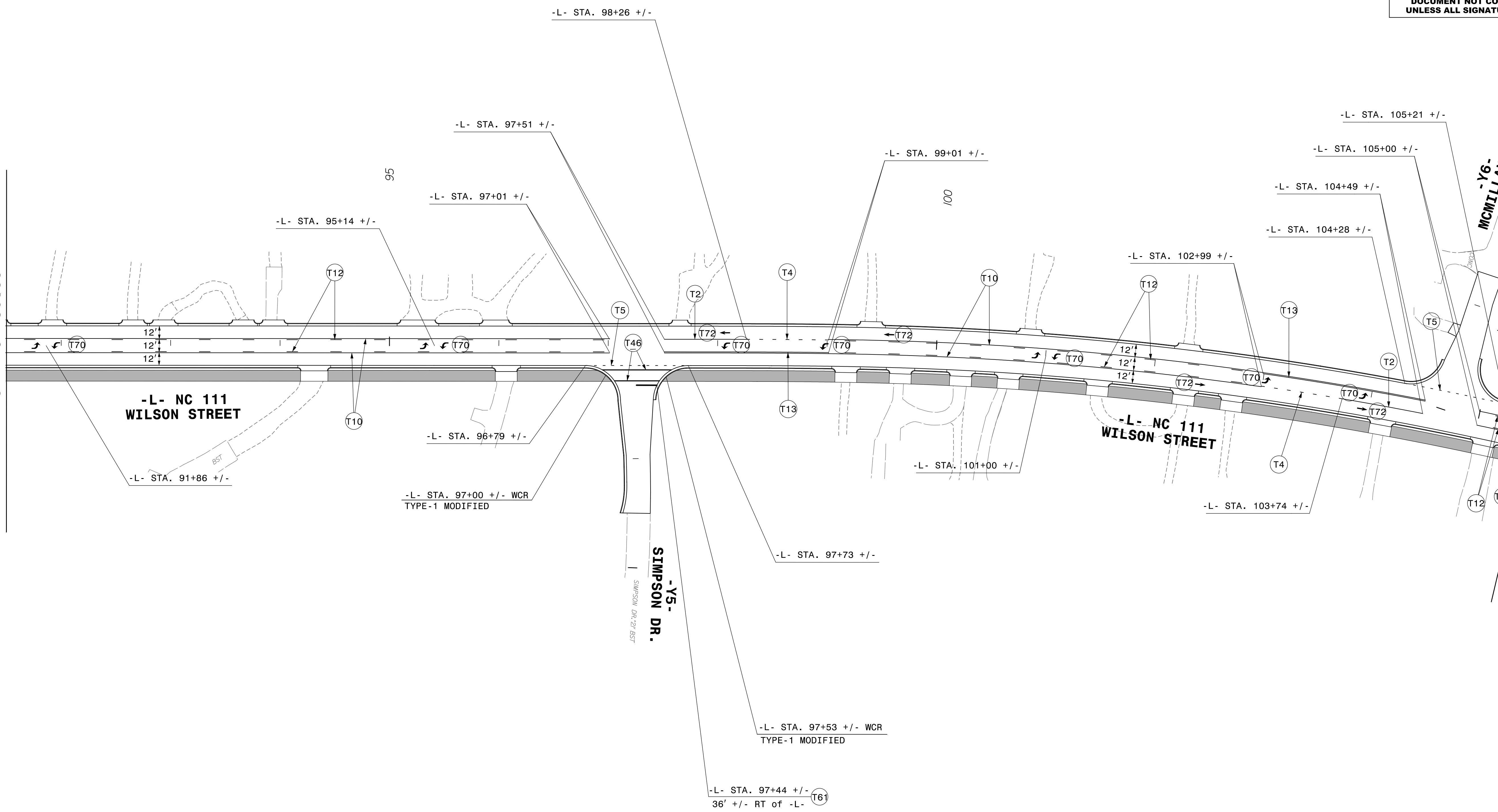

3/13/2023
Z:\188771-06 NCDOT NC III\U-4424\Traffic\Pavement Markings\U-4424_pmp_psh_10.dgn
USEB04421

**PAVEMENT MARKING
PLAN SHEET**

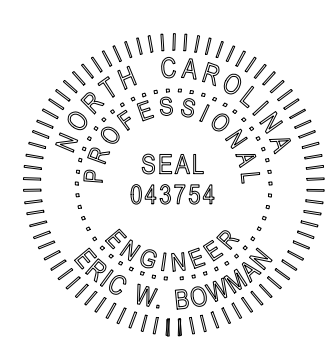
TIP NO. U-4424	SHEET NO. PMP-11
APPROVED: <i>Eric W Bowman</i> <small>DATE: 5/2/2023</small>	
SEAL 	
DOCUMENT NOT CONSIDERED FINAL UNLESS ALL SIGNATURES COMPLETED	

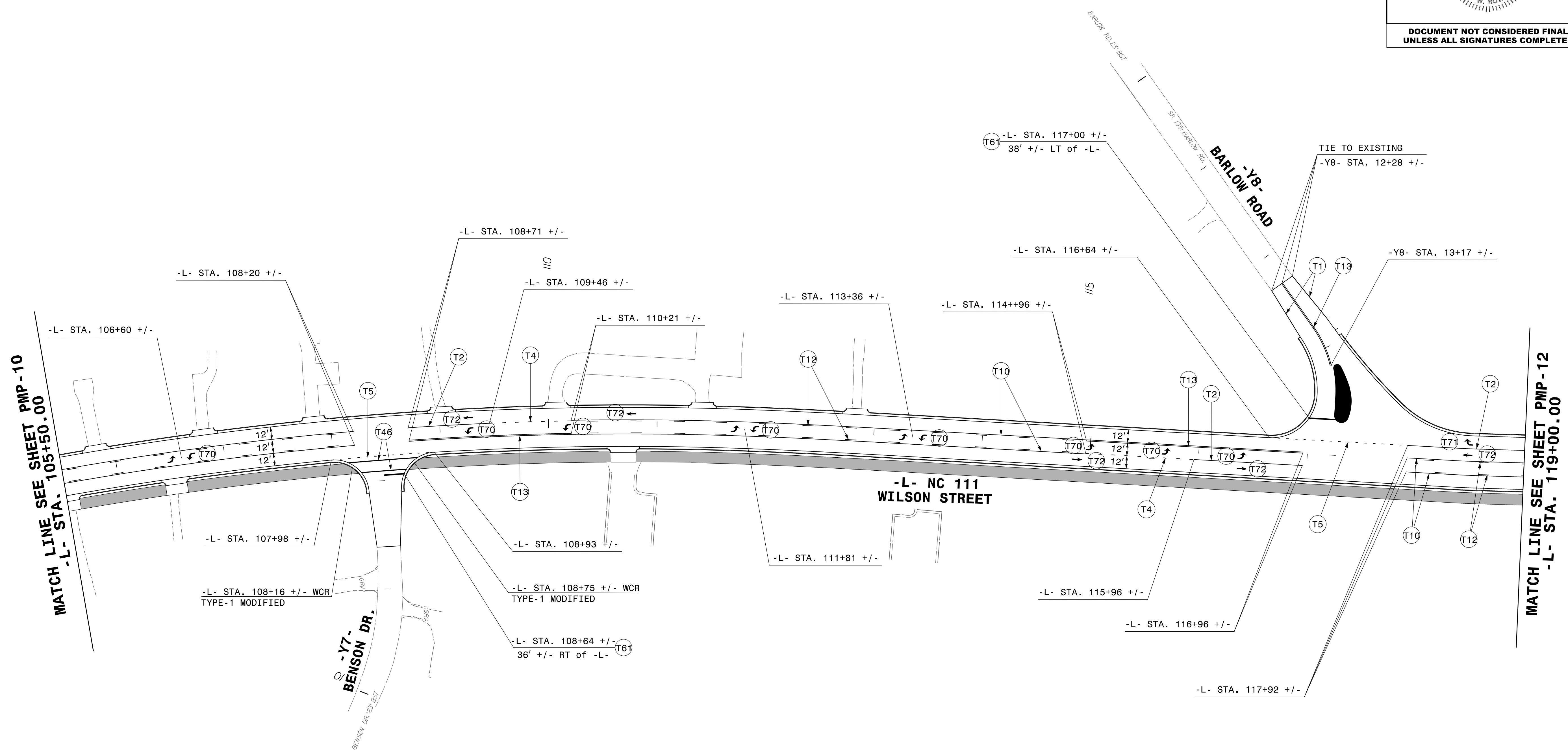
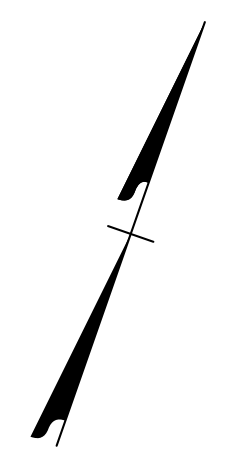

3/13/2023
Z:\188771-06 NCDOT NC III\U-4424\Traffic\Pavement Markings\U-4424_pmp_psh.ll.dgn
USEB04421

**PAVEMENT MARKING
PLAN SHEET**

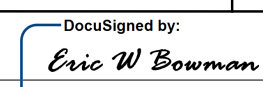
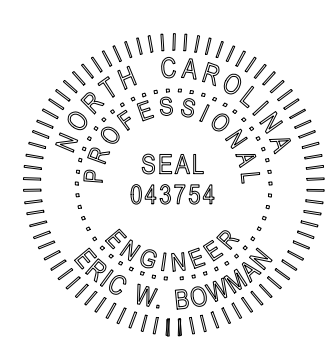
TIP NO. U-4424	SHEET NO. PMP-12
APPROVED:  Eric W. Bowman DADA2D3C6B0246F...	
DATE: 5/2/2023	
SEAL 	
DOCUMENT NOT CONSIDERED FINAL UNLESS ALL SIGNATURES COMPLETED	

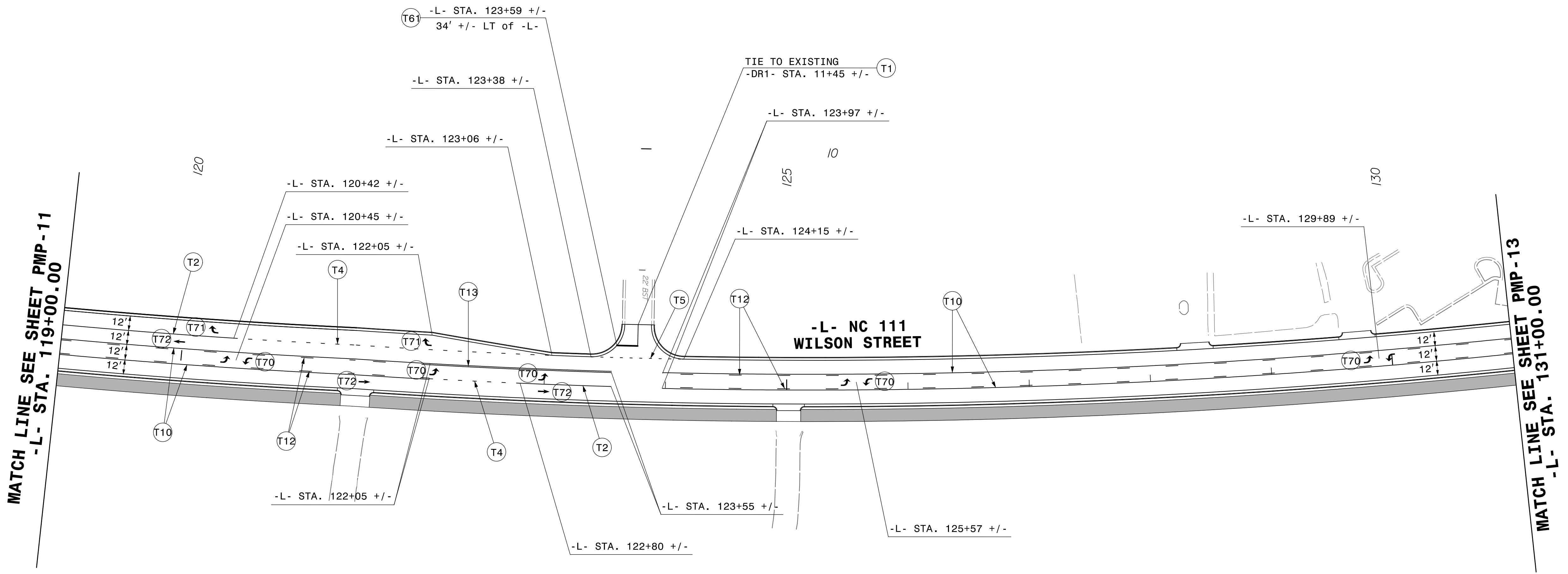
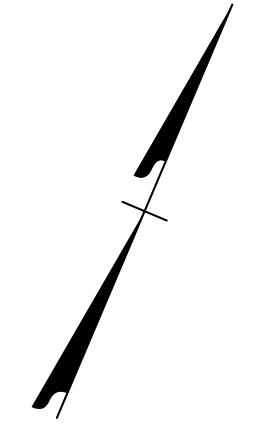

MATCH LINE SEE SHEET PMP-11
-L- STA. 119+00.00

MATCH LINE SEE SHEET PMP-13
-L- STA. 131+00.00

**PAVEMENT MARKING
PLAN SHEET**

3/13/2023
Z:\188771-06 NCDOT NC III\U-4424\Traffic\Pavement Markings\U-4424_pmp_psh_12.dgn
USEB04421

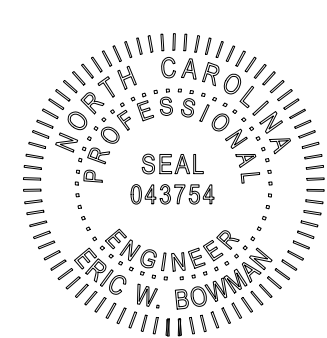
TIP NO. U-4424	SHEET NO. PMP-13
APPROVED: <i>Eric W. Bowman</i> <small>DeaSigned by: DADA2D3CB0246F</small>	
DATE: 5/2/2023	
SEAL 	
DOCUMENT NOT CONSIDERED FINAL UNLESS ALL SIGNATURES COMPLETED	

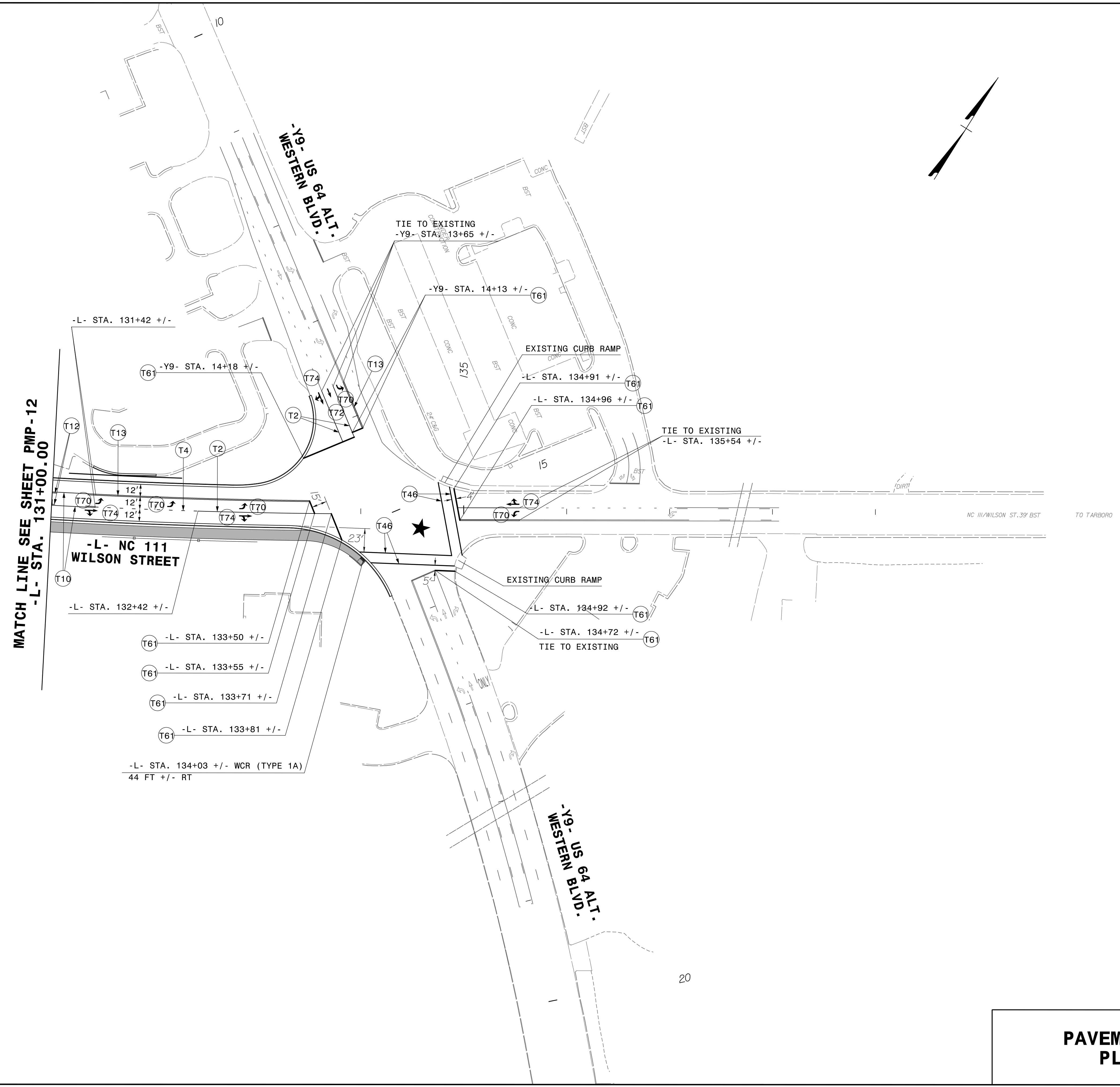

3/13/2023
Z:\188771-06 NCDOT NC III\U-4424\Traffic\Pavement Markings\U-4424_pmp_psh_13.dgn
USEB04421

**PAVEMENT MARKING
PLAN SHEET**