

5/28/23

**wsp**  
 WSP USA  
 434 EYETTEVILLE STREET  
 SUITE 1500  
 RALEIGH, NC 27601  
 TEL: 1.919.836.4040  
 FAX: 1.919.836.4099  
 LICENSE NO. F-0165

PROJECT REFERENCE NO. U-4424	SHEET NO. 18
ROADWAY DESIGN ENGINEER	HYDRAULICS ENGINEER

**DOCUMENT NOT CONSIDERED FINAL  
UNLESS ALL SIGNATURES COMPLETED**

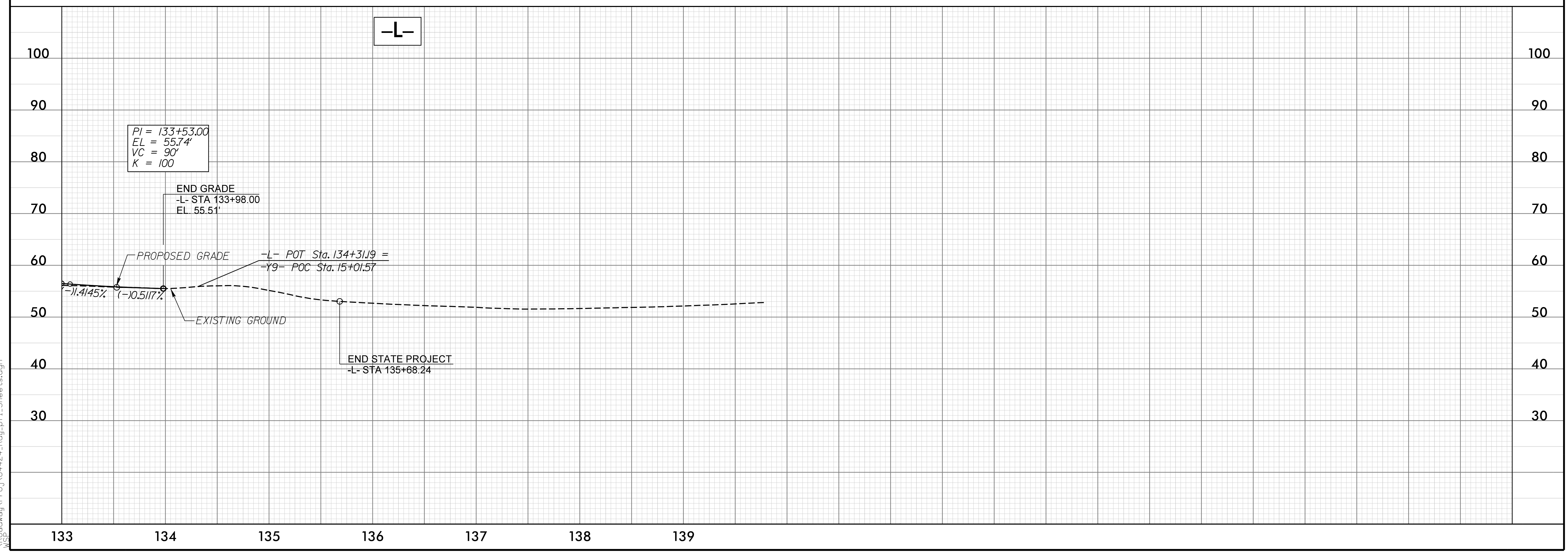
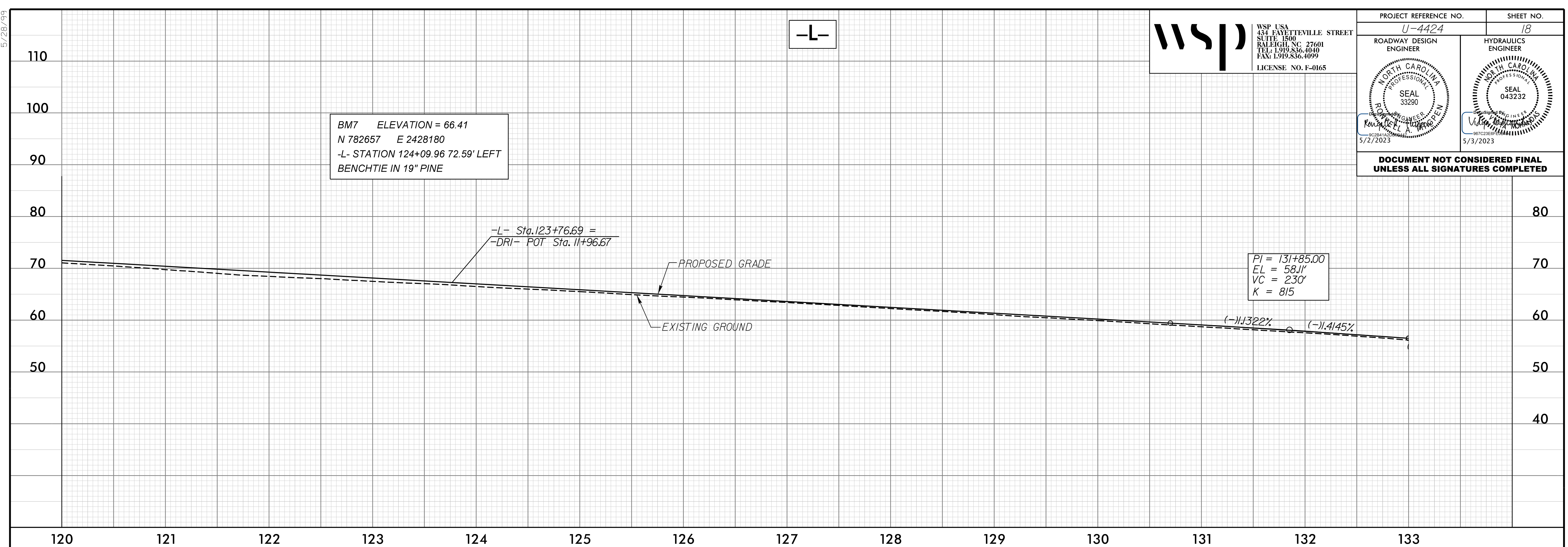

09-MAR-2023 17:30  
 N:\Roadway\Proj\U4424\_Rdy.pfl\_Sheets.dgn  
 WSP

5/28/23

-Y-

-Y1-

**wsp** WSP USA  
 434 EYETTEVILLE STREET  
 SUITE 1500  
 RALEIGH, NC 27601  
 TEL: 1.919.836.4040  
 FAX: 1.919.836.4099  
 LICENSE NO. F-0165

PROJECT REFERENCE NO. U-4424	SHEET NO. 19
ROADWAY DESIGN ENGINEER	HYDRAULICS ENGINEER

DOCUMENT NOT CONSIDERED FINAL  
UNLESS ALL SIGNATURES COMPLETED

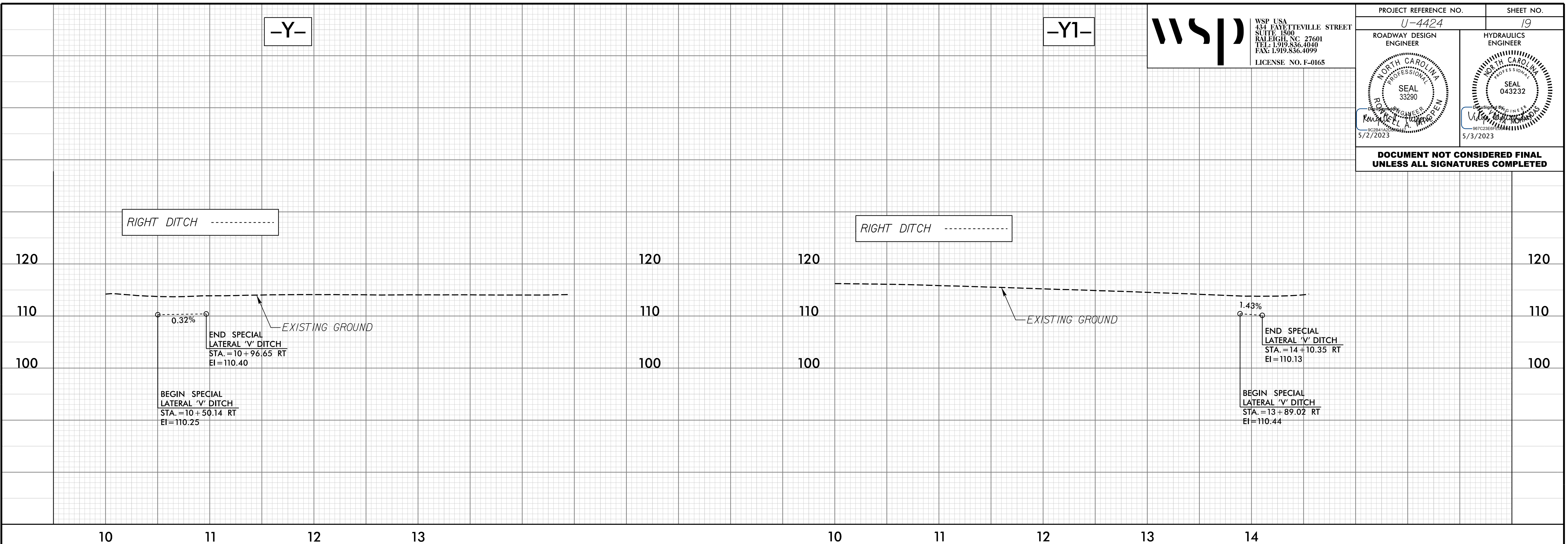

-Y2-

-Y3-

-Y4-

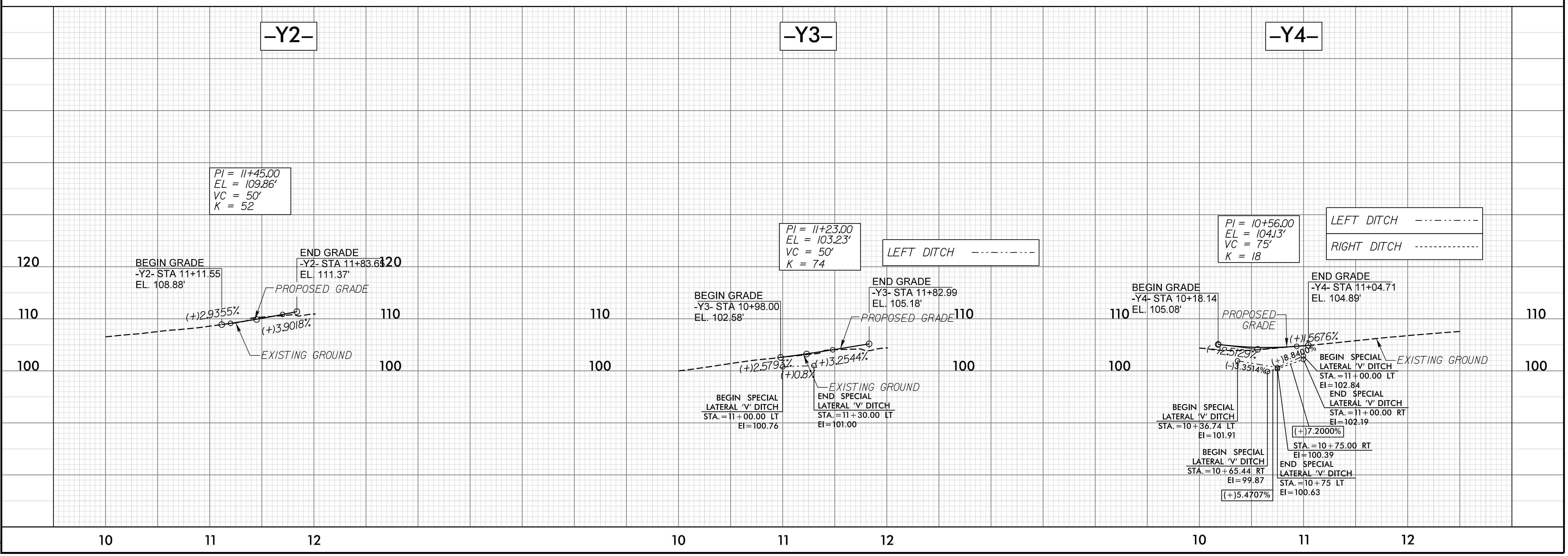

09-MAR-2023 17:30  
N:\Roadway\Projects\U4424\_Rdy.pfl\_Sheets.dgn

5/28/23

-Y5-

-Y7-



WSP USA  
434 EYETTEVILLE STREET  
SUITE 1500  
RALEIGH, NC 27601  
TEL: 1.919.836.4040  
FAX: 1.919.836.4099  
LICENSE NO. F-0165

PROJECT REFERENCE NO. U-4424	SHEET NO. 20
ROADWAY DESIGN ENGINEER	HYDRAULICS ENGINEER
5/2/2023	5/3/2023

-Y6-

DOCUMENT NOT CONSIDERED FINAL  
UNLESS ALL SIGNATURES COMPLETED

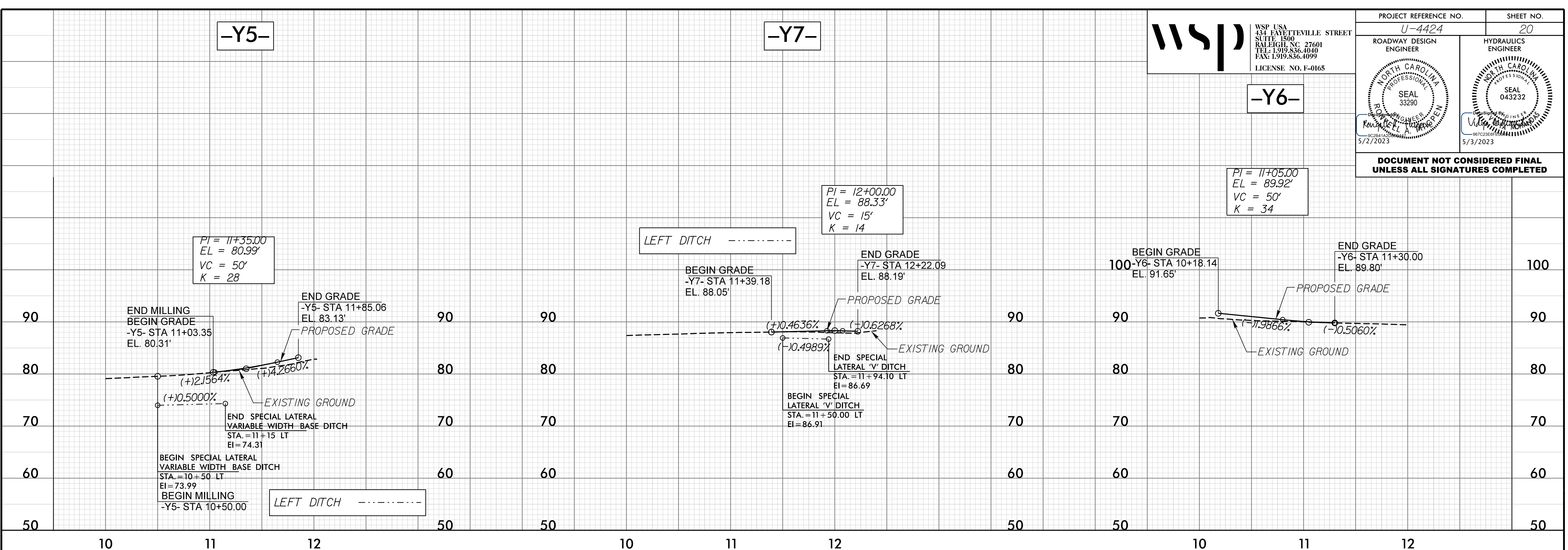

-Y8-

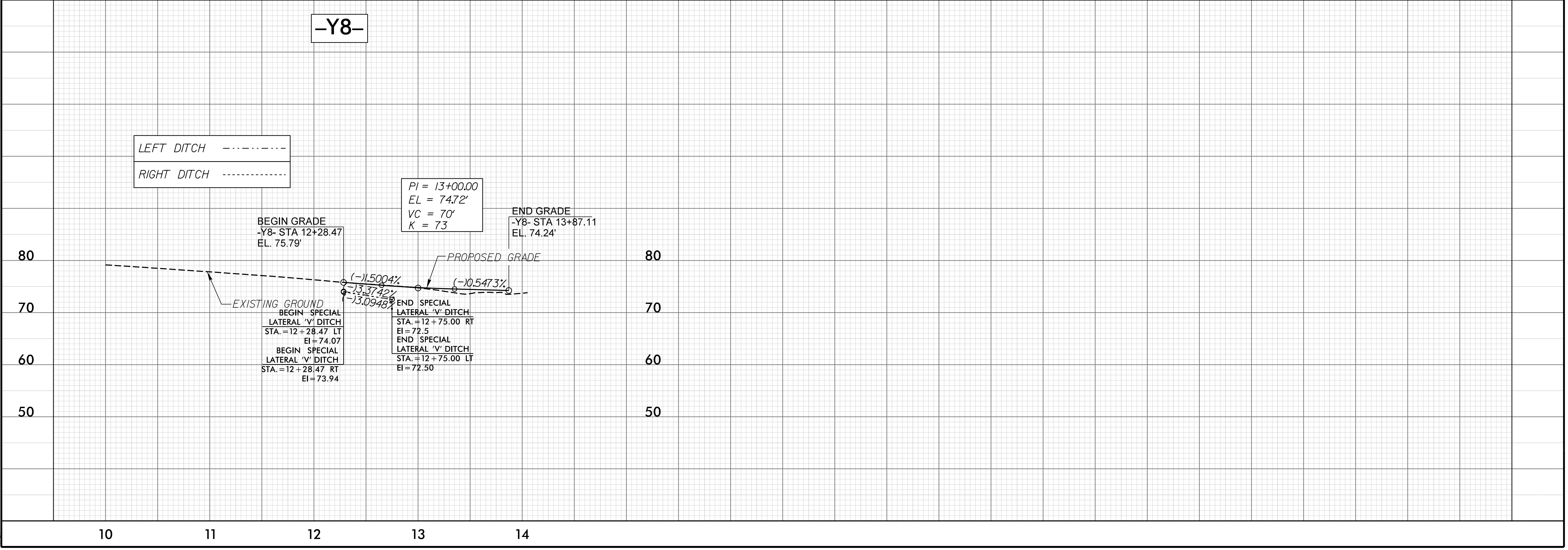

13-MAR-2023 09:09  
N:\Roadway\Projects\U4424\_Rdy.pfl\_Sheets.dgn  
WSE



5/28/23

-Y9-

**wsp**  
 WSP USA  
 434 EYETTEVILLE STREET  
 SUITE 1500  
 RALEIGH, NC 27601  
 TEL: 1.919.836.4040  
 FAX: 1.919.836.4099  
 LICENSE NO. F-0165

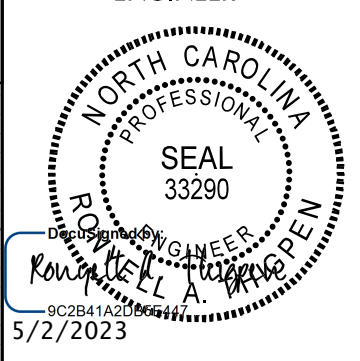
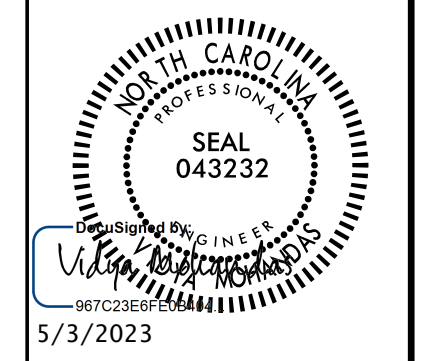
PROJECT REFERENCE NO. U-4424	SHEET NO. 21
ROADWAY DESIGN ENGINEER	HYDRAULICS ENGINEER
	

BM8 ELEVATION = 63.11  
 N 783412 E 2428753  
 BY STATION 18+63.00 121 LEFT  
 BENCHTIE IN 13" OAK

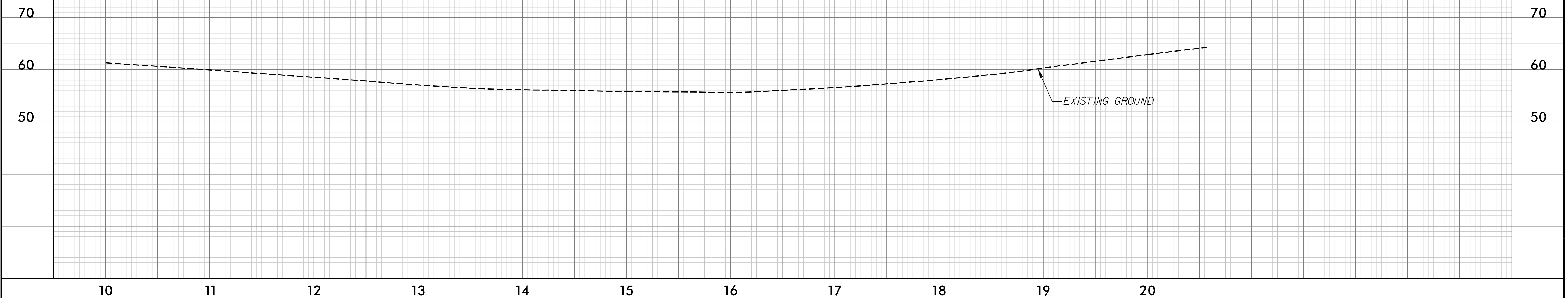

-DR1-

PI = 11+61.26  
 EL = 66.18'  
 VC = 30'  
 K = 53

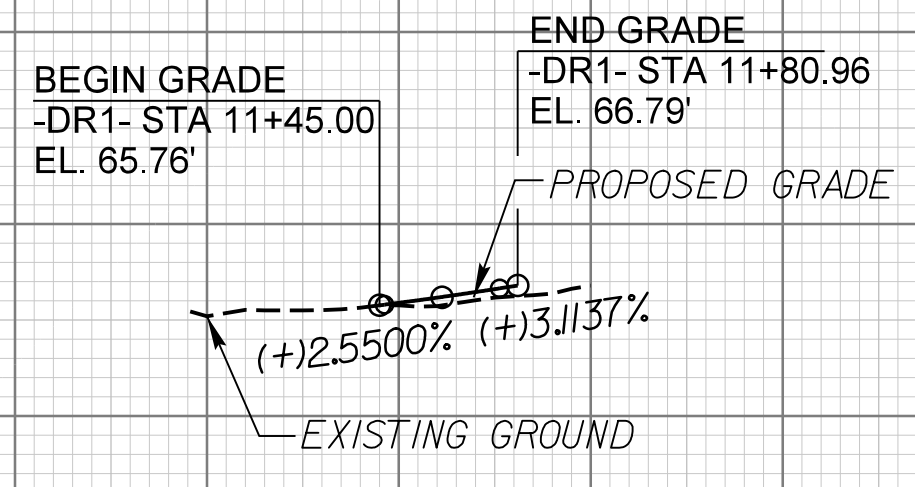

09-MAR-2023 17:30  
 N:\Roadway\Proj\U4424\_Rdy.pfl\_Sheets.dgn  
 WSP

11

12

5/28/23

# -US64- LT.

**wsp**  
 WSP USA  
 434 FAYETTEVILLE STREET  
 SUITE 1500  
 RALEIGH, NC 27601  
 TEL: 1.919.836.4040  
 FAX: 1.919.836.4099  
 LICENSE NO. F-0165

PROJECT REFERENCE NO. <i>U-4424</i>	SHEET NO. <i>22</i>
ROADWAY DESIGN ENGINEER	HYDRAULICS ENGINEER

**DOCUMENT NOT CONSIDERED FINAL UNLESS ALL SIGNATURES COMPLETED**

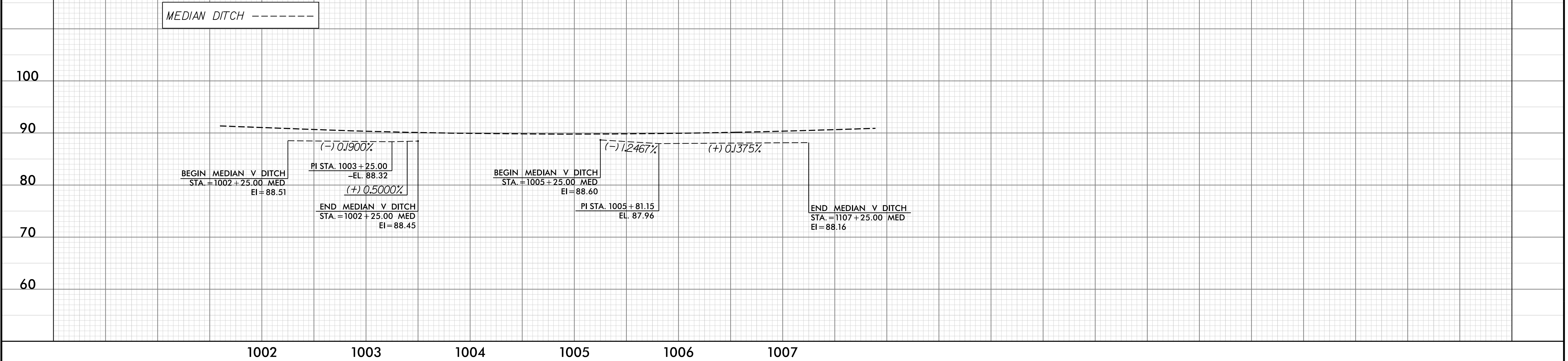

# -US64- RT.

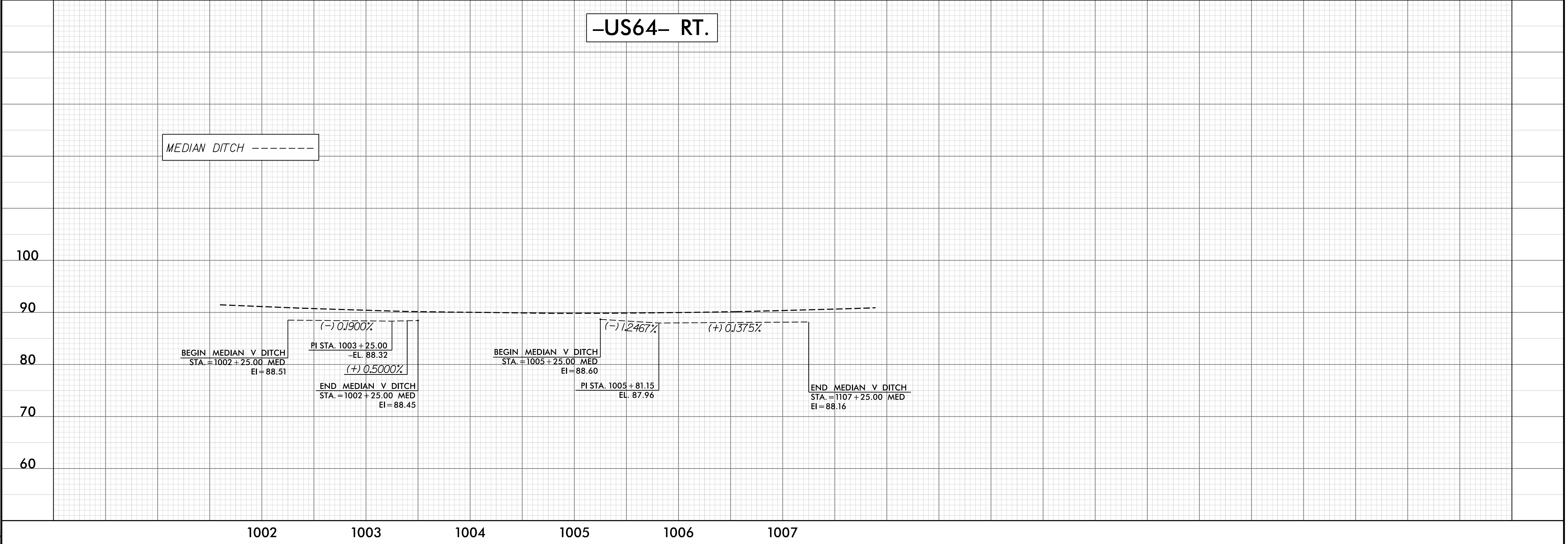

09-MAR-2023 17:30  
 N:\Roadway\Projects\U4424\_Rdy.pfl\_Sheets.dgn  
 WSP