

PLAN

PORTION OF EXISTING END BENT, CURTAIN WALL AND WINGWALL TO BE REMOVED AS REQUIRED TO FACILITATE CONSTRUCTION OF END BENT WIDENING.

NOTES:

- CURTAIN WALL SHALL BE PLACED BEFORE APPLYING THE EPOXY PROTECTIVE COATING.
- THE CONCRETE IN THE SHADED AREA OF THE WING SHALL BE POURED AFTER THE CONCRETE PARAPET IS CAST IF SLIP FORMING IS USED.
- THE TOP SURFACE AREAS OF THE END BENT CAP SHALL BE CURED IN ACCORDANCE WITH THE STANDARD SPECIFICATIONS EXCEPT THE MEMBRANE CURING COMPOUND METHOD SHALL NOT BE USED.
- INSTALL THE 4"Ø DRAIN PIPE THROUGH THE WING WALL AS REQUIRED FOR REINFORCED BRIDGE APPROACH FILLS. SEE ROADWAY PLANS. REINFORCING STEEL IN THE WING WALL MAY BE SHIFTED AS NECESSARY TO CLEAR THE DRAIN PIPE.
- FOR SECTION A-A AND B-B, SEE SHEET 4 OF 4.
- FOR UPPER PORTION OF CURTAIN WALL, SEE SUPERSTRUCTURE SHEETS.
- FOR PILE SPLICE DETAILS, SEE SHEET 4 OF 4.
- FOR BEARING DETAILS, SEE "ELASTOMERIC BEARING DETAILS" SHEET.
- *9D1 DRILLED HOLE AND FINAL EMBEDMENT SHALL BE PER ADHESIVE BONDING MATERIAL MANUFACTURER'S RECOMMENDATIONS. MINIMUM EMBEDMENT IS 3'-2".
- THE CONTRACTOR SHALL USE ADHESIVELY ANCHORED DOWELS TO CONNECT THE NEW AND EXISTING END BENTS. LEVEL 1 TESTING IS REQUIRED. THE YIELD LOAD OF THE DOWELS IS 60 KIPS. THE CONTRACTOR SHALL PLACE ADHESIVELY ANCHORED DOWELS IN ACCORDANCE WITH ARTICLE 420-13 OF THE STANDARD SPECIFICATIONS.
- THE TOP SURFACE OF THE CAP EXCEPT THE BRIDGE SEAT BUILDUPS SHALL BE SLOPED TRANSVERSELY FROM THE FILL FACE TO THE BACK FACE AT THE RATE OF 2%.
- * - TO BE FIELD VERIFIED.
- ** - PRIOR TO CASTING END BENT, THE CONTRACTOR SHALL FIELD VERIFY ACTUAL BRIDGE DECK ELEVATIONS AT THE SAW-CUT LINE AND COMPARE TO COMPUTED ELEVATIONS. IF DISCREPANCIES ARE OBSERVED ADJUSTMENTS TO SEAT ELEVATIONS MAY BE REQUIRED.

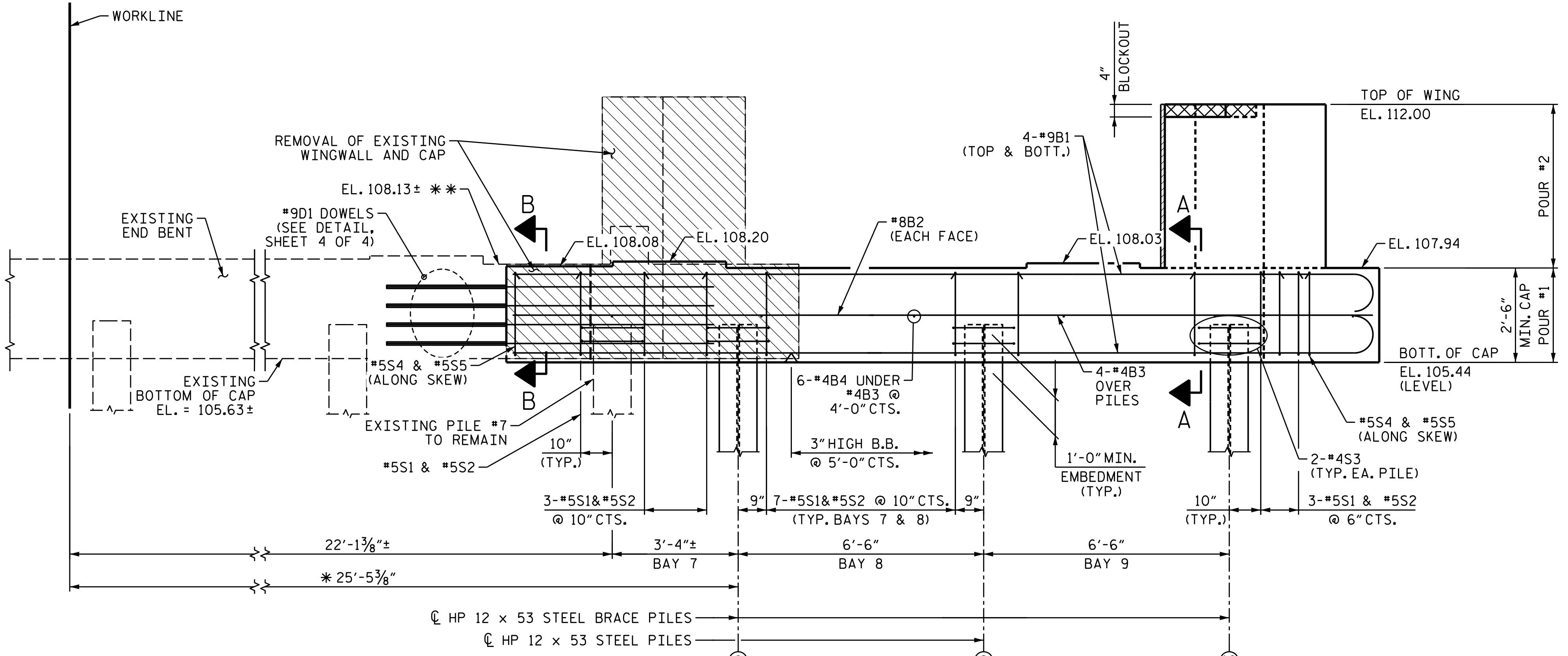

ELEVATION
WING NOT SHOWN FOR CLARITY

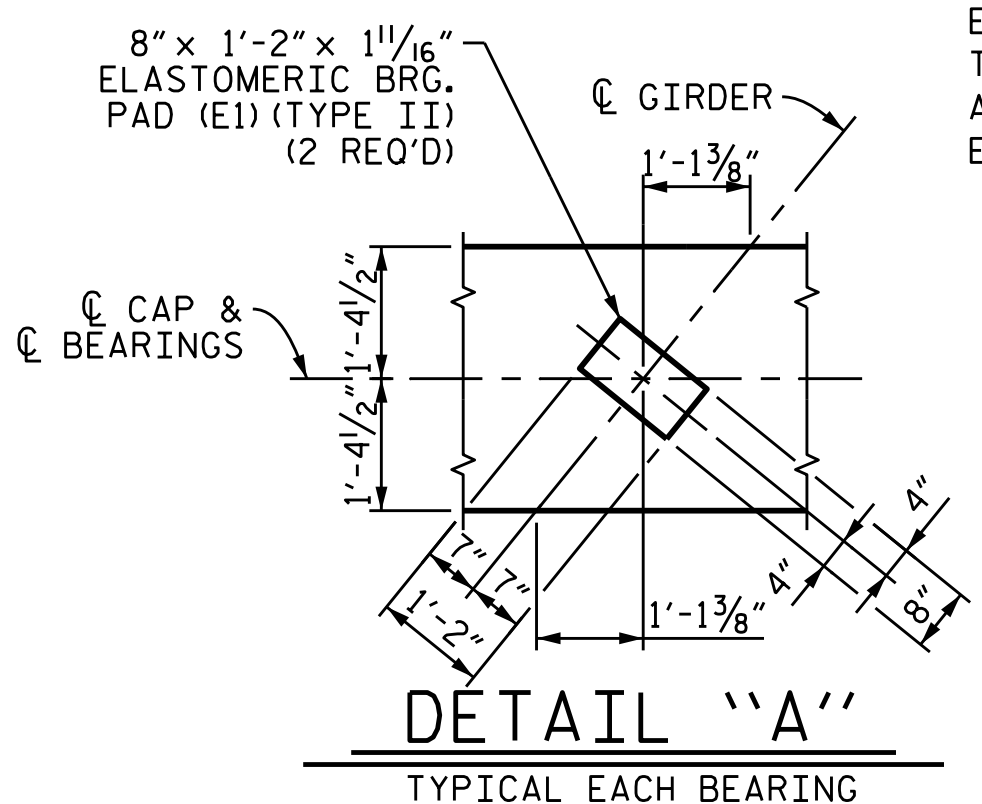

DETAIL "A"
TYPICAL EACH BEARING

PROJECT NO. U-4424
EDGEcombe COUNTY
STATION: 66+24.84 -L-
SHEET 1 OF 4

STATE OF NORTH CAROLINA
DEPARTMENT OF TRANSPORTATION
RALEIGH
SUBSTRUCTURE
END BENT 1
PLAN & ELEVATION

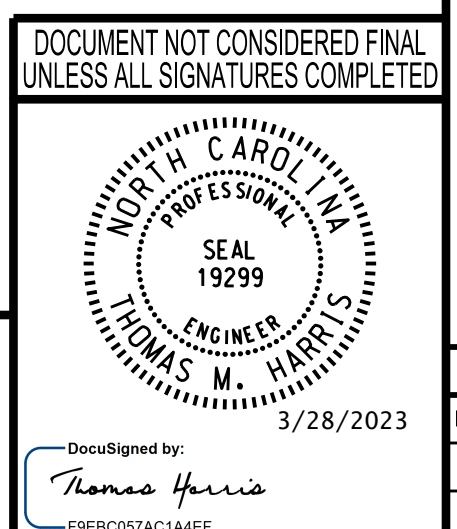

REVISIONS						SHEET NO.
NO.	BY:	DATE:	NO.	BY:	DATE:	S-27
1			3			TOTAL SHEETS
2			4			37

3/28/2023 J:\188771-06 NCDOT_NC_111\U-4424\Structure\Drawings\401_055_U4424_SML.EBI_027.dgn

DESIGNED BY: J. WHEATLEY DATE: MAR 2023
DRAWN BY: M. HOBBS DATE: MAR 2023
CHECKED BY: J.N. SMITH DATE: MAR 2023
DESIGN ENGINEER OF RECORD: T.M. HARRIS DATE: MAR 2023