

NOTES

THE GUARDRAIL ANCHOR ASSEMBLY SHALL CONSIST OF A 1/4" HOLD DOWN PLATE AND 7 - 7/8" Ø BOLTS WITH NUTS AND WASHERS.

THE HOLD-DOWN PLATE SHALL CONFORM TO AASHTO M270 GRADE 36. AFTER FABRICATION, THE HOLD-DOWN PLATE SHALL BE HOT-DIP GALVANIZED IN ACCORDANCE WITH AASHTO M111.

BOLTS SHALL CONFORM TO THE REQUIREMENTS OF ASTM A307 AND NUTS SHALL CONFORM TO THE REQUIREMENTS OF AASHTO M291. BOLTS, NUTS AND WASHERS SHALL BE GALVANIZED. (AT THE CONTRACTOR'S OPTION, STAINLESS STEEL BOLTS, NUTS AND WASHERS MAY BE USED AS AN ALTERNATE FOR THE 7/8" Ø GALVANIZED BOLTS, NUTS AND WASHERS. THEY SHALL CONFORM TO OR EXCEED THE MECHANICAL REQUIREMENTS OF ASTM A307. THE USE OF THIS ALTERNATE SHALL BE APPROVED BY THE ENGINEER.)

THE GUARDRAIL ANCHOR ASSEMBLY IS REQUIRED AT ALL POINTS WHERE APPROACH GUARDRAIL IS TO BE ATTACHED TO THE END OF BARRIER RAIL. FOR POINTS OF ATTACHMENT, SEE SKETCH.

AFTER INSTALLATION, THE EXPOSED THREAD OF THE BOLT SHALL BE BURRED WITH A SHARP POINTED TOOL.

THE COST OF THE GUARDRAIL ANCHOR ASSEMBLY SHALL BE INCLUDED IN THE UNIT CONTRACT PRICE BID FOR VERTICAL CONCRETE BARRIER RAIL.

THE VERTICAL REINFORCING BARS MAY BE SHIFTED SLIGHTLY IN THE VERTICAL CONCRETE BARRIER RAIL TO CLEAR ASSEMBLY BOLTS.

THE 1 1/4" Ø HOLES SHALL BE FORMED OR DRILLED WITH A CORE BIT. IMPACT TOOLS WILL NOT BE PERMITTED. ANY CONCRETE DAMAGED BY THIS WORK SHALL BE REPAIRED TO THE SATISFACTION OF THE ENGINEER.

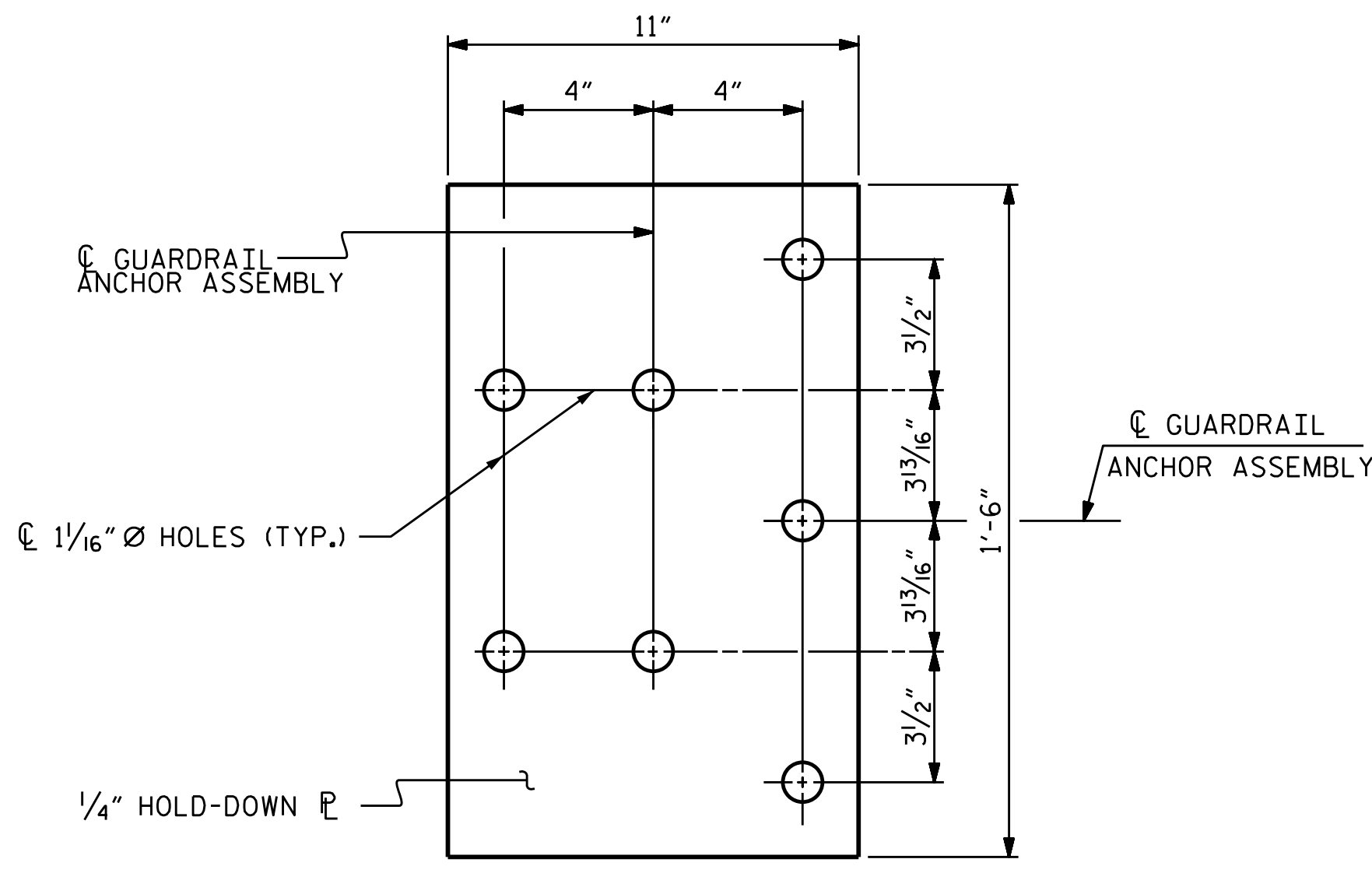

PLAN

FOR LOCATION OF GUARDRAIL ANCHOR ASSEMBLY, SEE "PLAN" BELOW

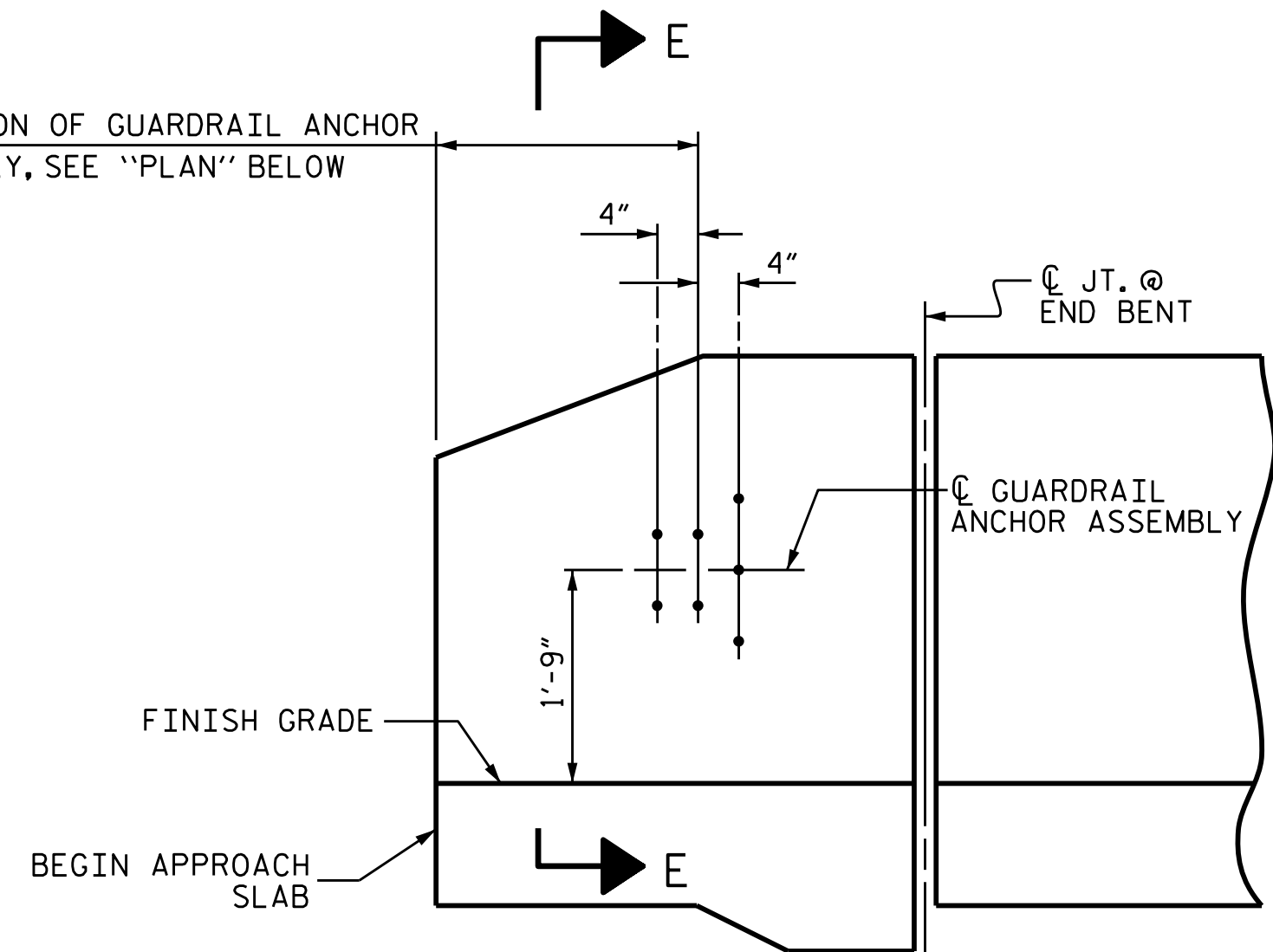

ELEVATION

GUARDRAIL ANCHOR ASSEMBLY DETAILS

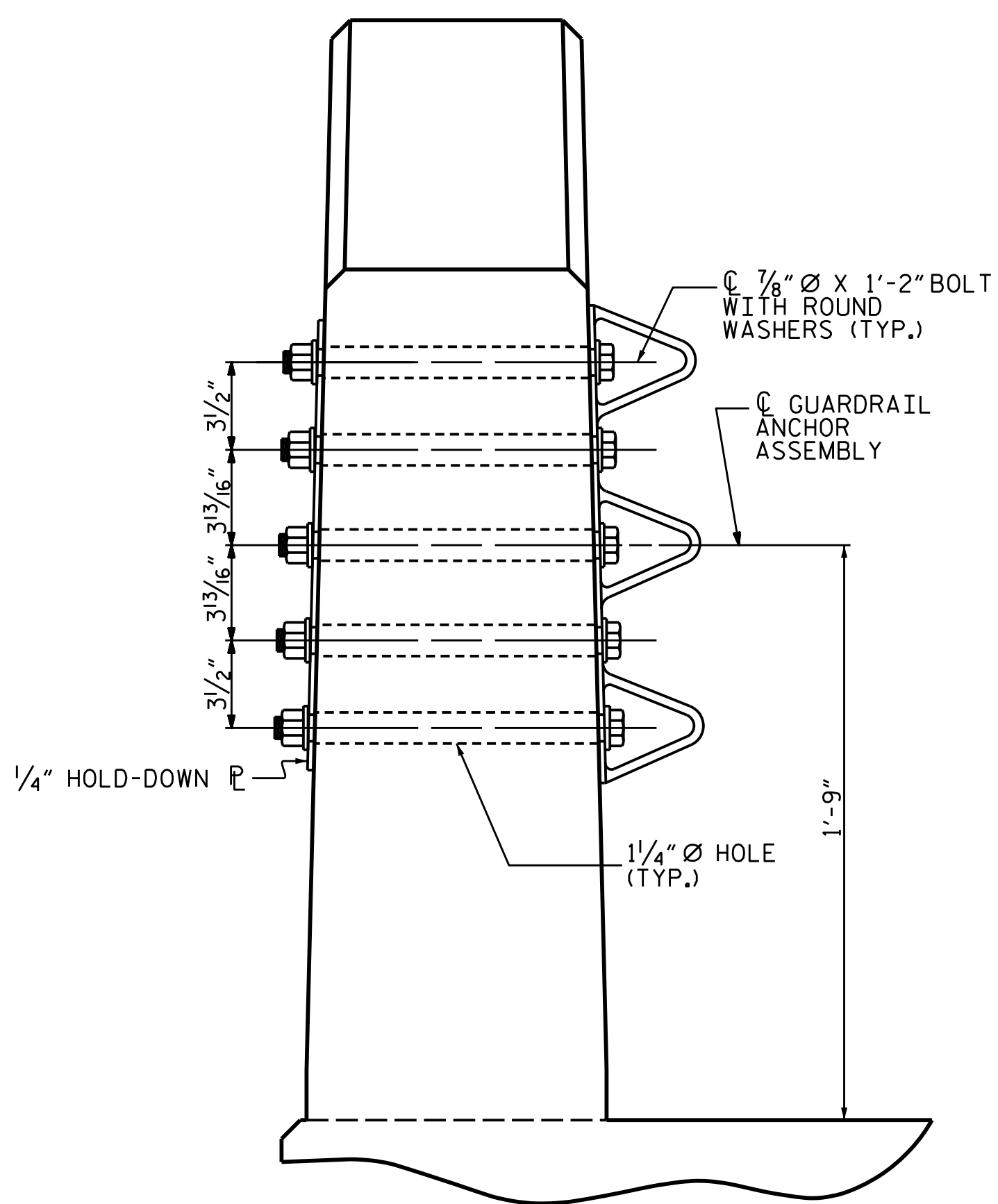

SECTION E-E

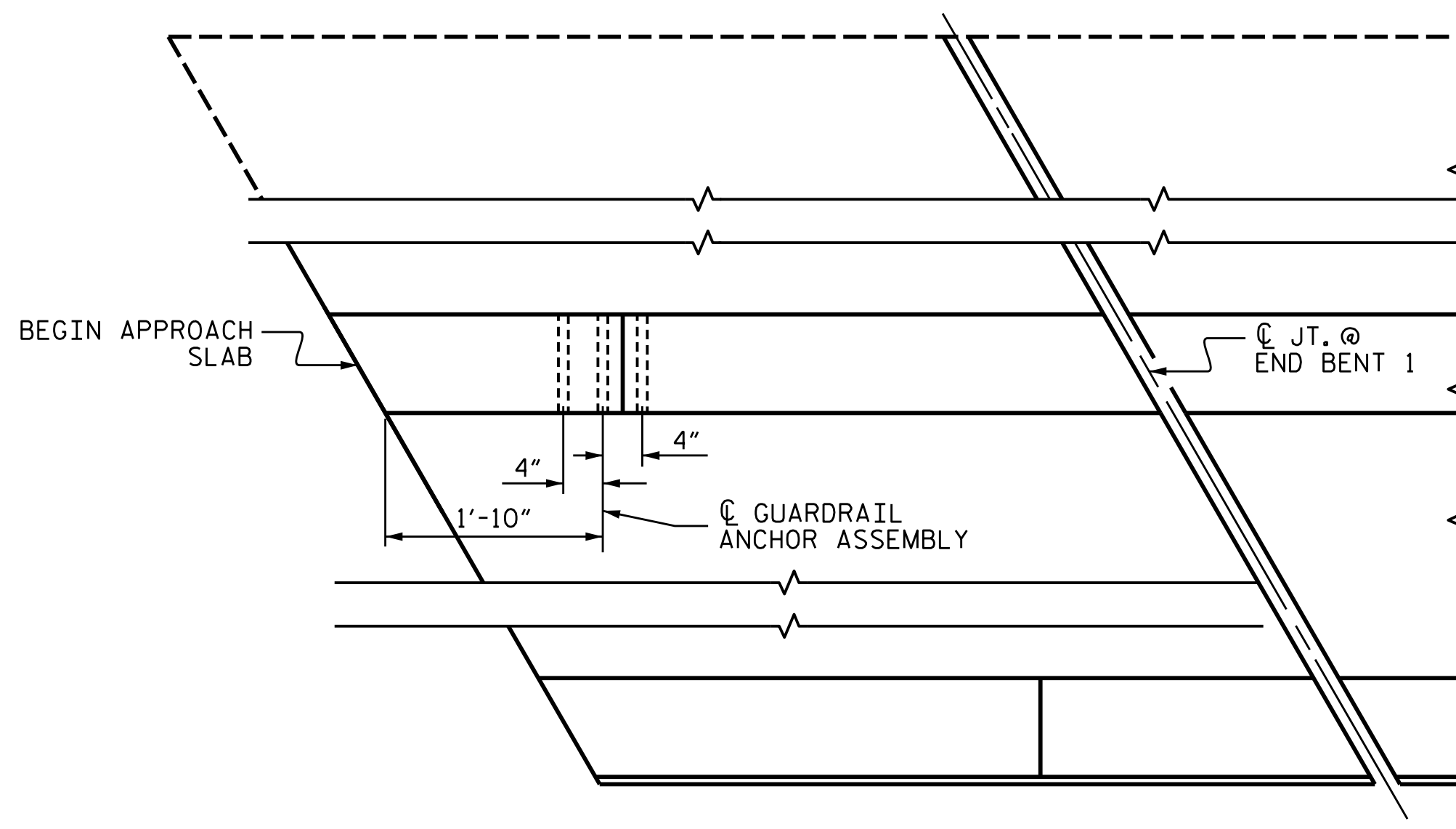

PLAN

LOCATION OF ANCHORS FOR GUARDRAIL

BEGIN APPROACH SLAB SHOWN, END APPROACH SLAB SIMILAR.

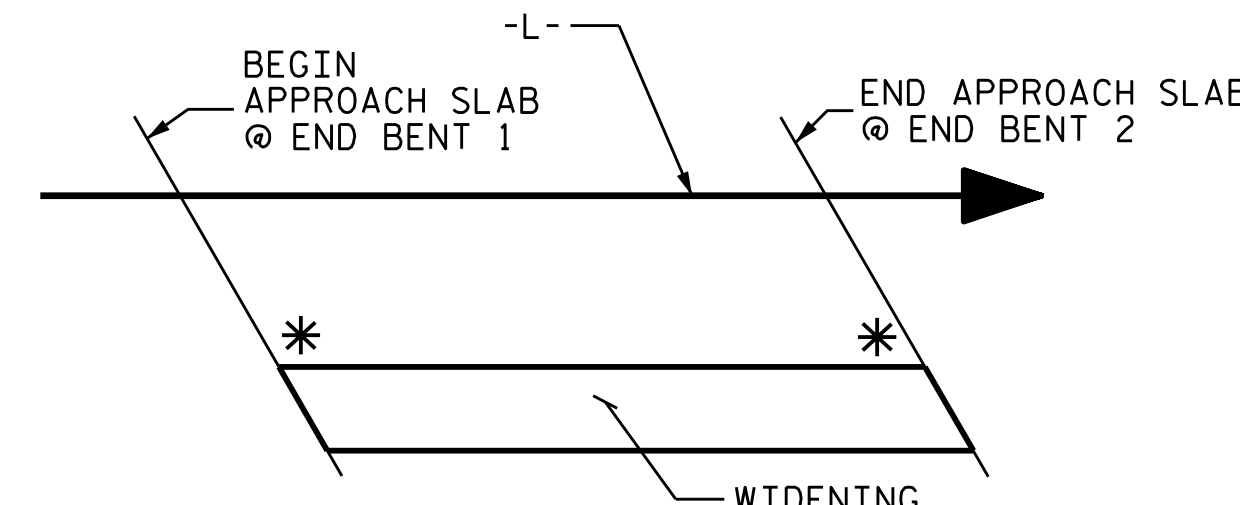

SKETCH SHOWING POINTS OF ATTACHMENT

* DENOTES GUARDRAIL ANCHOR ASSEMBLY

PROJECT NO. U-4424
EDGEcombe COUNTY
 STATION: 66+24.84 -L-

STATE OF NORTH CAROLINA
 DEPARTMENT OF TRANSPORTATION
 RALEIGH
 STANDARD
 GUARDRAIL ANCHORAGE
 DETAILS
 FOR VERTICAL CONCRETE
 BARRIER RAIL

DOCUMENT NOT CONSIDERED FINAL
 UNLESS ALL SIGNATURES COMPLETED

3/28/2023

REVISIONS						SHEET NO.
NO.	BY:	DATE:	NO.	BY:	DATE:	S-25
1			3			TOTAL SHEETS
2			4			37

STD. NO. GRA3

3/28/2023 J:\188771-06_NCDOT_NC_111\U-4424\Structures\Dr-off\ing\DGNS\401_051_U4424_SML_CR_025.dgn

DRAWN BY : MAA 5/10	REV. 1/15	MAA/TMG
CHECKED BY : GM 5/10	REV. 12/17	MAA/THC
	REV. 5/18	MAA/THC
DESIGNED BY : J. WHEATLEY	DATE : MAR 2023	
DRAWN BY : J. WHEATLEY	DATE : MAR 2023	
CHECKED BY : T. KIRSCHBAUM	DATE : MAR 2023	
DESIGN ENGINEER OF RECORD : T. HARRIS	DATE : MAR 2023	