

5/28/23

**wsp**  
 WSP USA  
 434 EYETTEVILLE STREET  
 SUITE 1500  
 RALEIGH, NC 27601  
 TEL: 1.919.836.4040  
 FAX: 1.919.836.4099  
 LICENSE NO. F-0165

PROJECT REFERENCE NO. U-4424	SHEET NO. 18
ROADWAY DESIGN ENGINEER 	HYDRAULICS ENGINEER 

**DOCUMENT NOT CONSIDERED FINAL  
UNLESS ALL SIGNATURES COMPLETED**

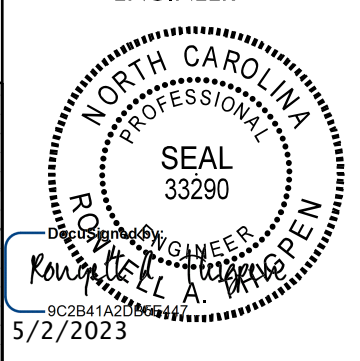
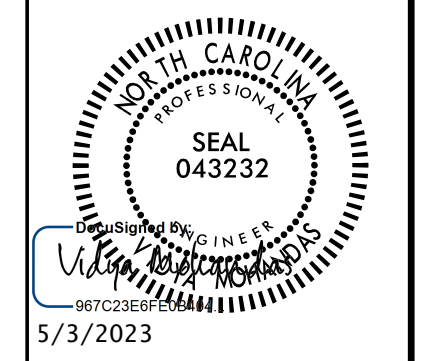
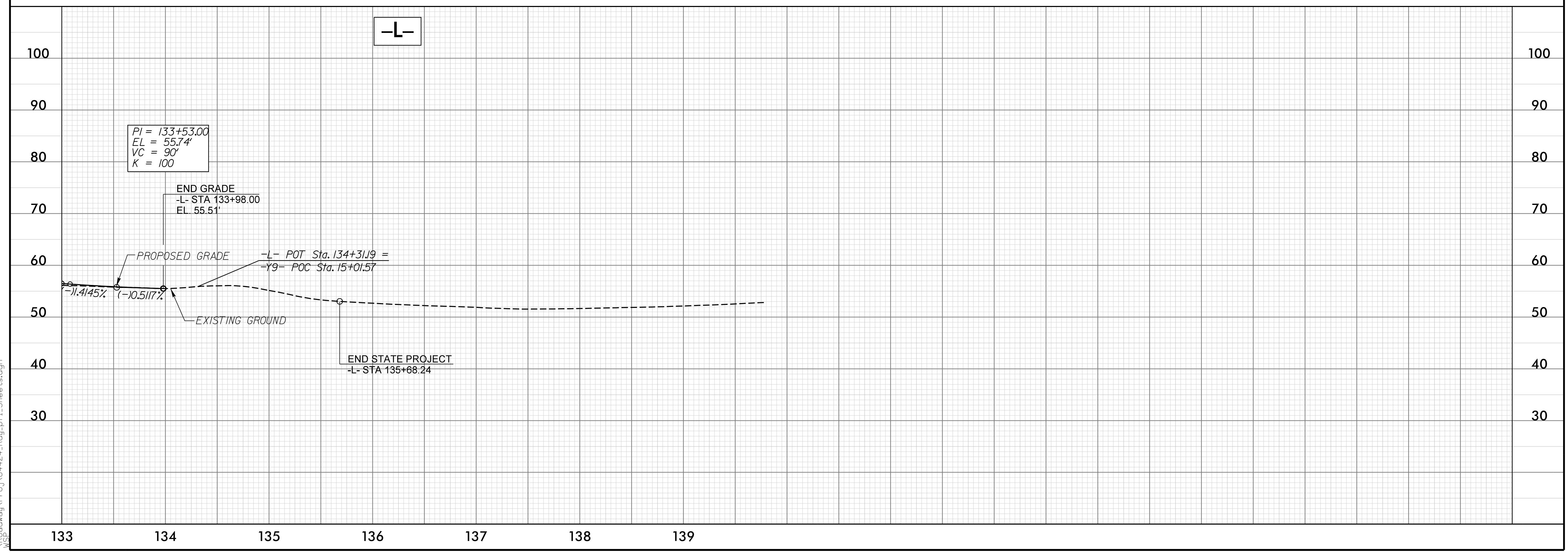
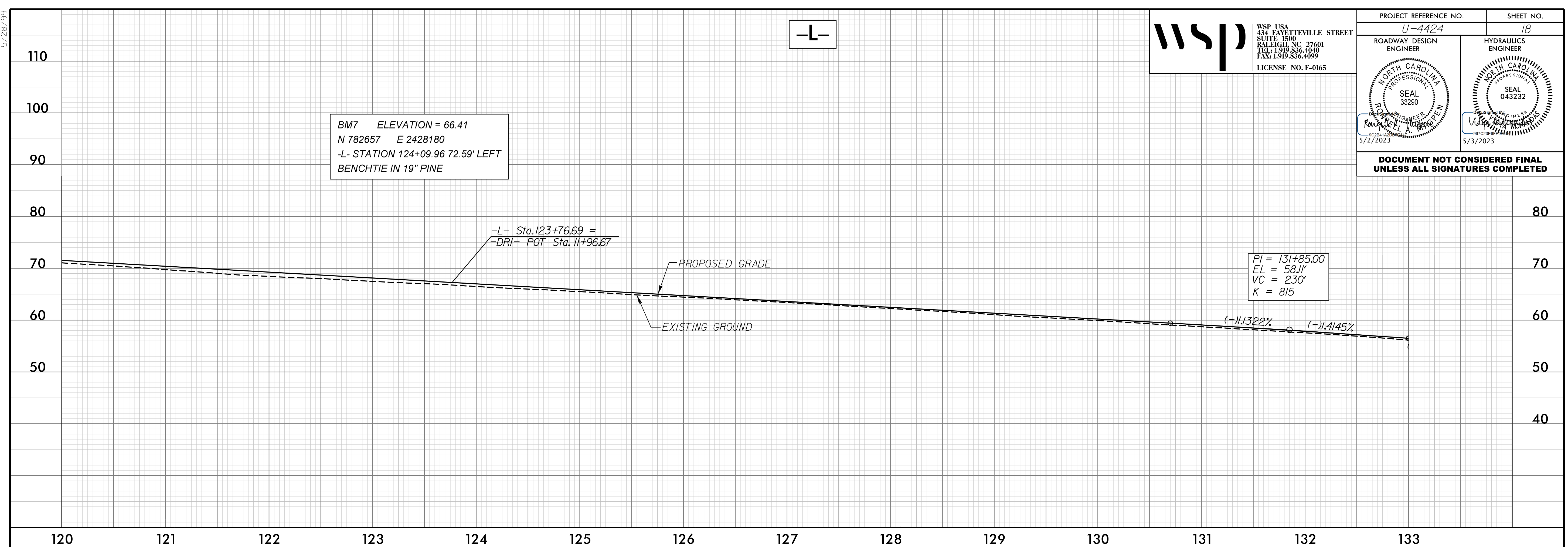

09-MAR-2023 17:30  
 N:\Roadway\Proj\U4424\_Rdy.pfl\_Sheets.dgn  
 WSE