

| | |
|--|-----------|
| TIP NO. | SHEET NO. |
| BR-0043 | PMP-1 |
| APPROVED: _____ | |
| DATE: _____ | |
| SEAL | |
| | |
| Documented by: <i>Jeffrey A. Koontz</i> 84EBFECCD2384F7... | |
| DOCUMENT NOT CONSIDERED FINAL UNLESS ALL SIGNATURES COMPLETED | |

**STATE OF NORTH CAROLINA
DEPARTMENT OF TRANSPORTATION**

PAVEMENT MARKING PLAN

ROCKINGHAM COUNTY

**LOCATION: BRIDGE 780151 ON US 158 NC 14
OVER US 29**

T.I.P.: BR-0043

INDEX

| SHEET NO. | DESCRIPTION |
|------------------|--|
| PMP-1 | PAVEMENT MARKING PLAN TITLE AND SCHEDULE SHEET |
| PMP-1A | PAVEMENT MARKING SPECIAL DETAIL |
| PMP-2 THRU PMP-4 | PAVEMENT MARKING DETAILS |

GENERAL NOTES

THE FOLLOWING GENERAL NOTES APPLY AT ALL TIMES FOR THE DURATION OF THE CONSTRUCTION PROJECT, EXCEPT WHEN OTHERWISE NOTED IN THE PLAN, OR DIRECTED BY THE ENGINEER.

- A) INSTALL PAVEMENT MARKINGS AND PAVEMENT MARKERS ON THE FINAL SURFACE AS FOLLOWS:

| | | |
|-------------------------|----------|--------------|
| ROAD NAME | MARKING | MARKER |
| US 158 / NC 14 | POLYUREA | SNOWPLOWABLE |
| US 158 / NC 14 (BRIDGE) | POLYUREA | RAISED |
| US 29 & RAMPS | POLYUREA | SNOWPLOWABLE |
- B) TIE PROPOSED PAVEMENT MARKING LINES TO EXISTING PAVEMENT MARKING LINES.
- C) REMOVE/REPLACE ANY CONFLICTING/DAMAGED PAVEMENT MARKINGS AND MARKERS.
- D) STOP BAR LOCATION AT NON-SIGNALIZED INTERSECTIONS MAY BE ADJUSTED AS DIRECTED BY THE ENGINEER.
- E) UNLESS OTHERWISE SPECIFIED, HEATED-IN-PLACE THERMOPLASTIC MAY BE USED IN LIEU OF EXTRUDED THERMOPLASTIC FOR STOP BARS, SYMBOLS, CHARACTERS AND DIAGONALS. IF HEATED-IN-PLACE IS USED, IT SHALL BE PAID FOR USING THE EXTRUDED THERMOPLASTIC PAY ITEM.

**FINAL PAVEMENT
MARKING SCHEDULE**

| SYMBOL | DESCRIPTION | SYMBOL | DESCRIPTION |
|-----------------|--|----------------------|--------------------------------------|
| POLYUREA | | THERMOPLASTIC | |
| V1 | WHITE EDGELINE (4", 20 MIL) | T61 | WHITE STOPBAR (24", 90 MIL) |
| V2 | WHITE SOLID LANE LINE (4", 20 MIL) | T70 | LEFT TURN ARROW (90 MIL) |
| V3 | 10FT. WHITE SKIP (4", 20 MIL) | T71 | RIGHT TURN ARROW (90 MIL) |
| V4 | 3 FT.-9 FT./SP WHITE MINISKIP (4", 20 MIL) | T72 | STRAIGHT ARROW (90 MIL) |
| V5 | 2 FT.-6 FT./SP WHITE MINISKIP (4", 20 MIL) | T74 | COMBO. RIGHT/STRAIGHT ARROW (90 MIL) |
| V10 | YELLOW EDGELINE (4", 20 MIL) | T80 | WRONG-WAY RAMP ARROW (90 MIL) |
| V11 | YELLOW SINGLE CENTER (4", 20 MIL) | T100 | ALPHANUMERIC CHAR. (90 MIL) |
| V13 | YELLOW DOUBLE CENTER (4" 20 MIL) | T103 | 24" YIELD LINE TRIANGLE (90 MIL) |
| V20 | WHITE EDGELINE (6", 20 MIL) | | |
| V22 | 10FT. WHITE SKIP (6", 20 MIL) | | |
| V30 | YELLOW EDGELINE (6", 20 MIL) | | |
| V43 | WHITE SOLID LANE LINE (8", 20 MIL) | | |
| V44 | 3 FT. - 9 FT./SP WHITE MINISKIP (8", 20 MIL) | | |
| V50 | WHITE GORELINE (12", 20 MIL) | | |

ROADWAY STANDARD DRAWING

THE FOLLOWING ROADWAY STANDARDS AS APPEAR IN "ROADWAY STANDARD DRAWINGS" - PROJECT SERVICES UNIT - N.C. DEPARTMENT OF TRANSPORTATION - RALEIGH, N.C., DATED JANUARY 2018 ARE APPLICABLE TO THIS PROJECT AND BY REFERENCE HEREBY ARE CONSIDERED A PART OF THESE PLANS:

| STD. NO. | TITLE |
|----------|--|
| 1205.01 | PAVEMENT MARKINGS - LINE TYPES AND OFFSETS |
| 1205.02 | PAVEMENT MARKINGS - TWO-LANE AND MULTILANE ROADWAYS |
| 1205.04 | PAVEMENT MARKINGS - INTERSECTIONS |
| 1205.05 | PAVEMENT MARKINGS - TURN LANES |
| 1205.06 | PAVEMENT MARKINGS - LANE DROPS |
| 1205.08 | PAVEMENT MARKINGS - SYMBOLS AND WORD MESSAGES |
| 1205.09 | PAVEMENT MARKINGS - PAINTED ISLANDS |
| 1205.12 | PAVEMENT MARKINGS - BRIDGES |
| 1205.13 | PAVEMENT MARKINGS - LANE REDUCTION |
| 1250.01 | RAISED PAVEMENT MARKERS - INSTALLATION SPACING |
| 1251.01 | RAISED PAVEMENT MARKERS - PERMANENT AND TEMPORARY |
| 1253.01 | RAISED PAVEMENT MARKERS - SNOWPLOWABLE |
| 1261.01 | GUARDRAIL AND BARRIER DELINEATORS - INSTALLATION SPACING |
| 1261.02 | GUARDRAIL AND BARRIER DELINEATORS - TYPES AND MOUNTING |
| 1262.01 | GUARDRAIL END DELINEATION |

PLAN SUBMITTED TO:

DAVID STUTTS, PE

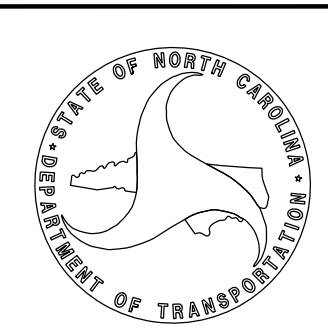

PLAN PREPARED BY:

JEFFREY KOONTZ, PE PROJECT ENGINEER
KALEAB MAREGN, PE DESIGN ENGINEER

AECOM

NC FIRM LICENSE No: F-0342
5438 Wade Park Boulevard, Suite 200
Raleigh, NC 27604
(919) 461-1100

| | |
|---|----------------------------|
| TIP NO. | SHEET NO. |
| BR - 0043 | DocuSigned by PMP - 1A |
| APPROVED: | <i>Matthew V. Springer</i> |
| DATE: | 8/13/2019 |
| SEAL | |
|  | |

STATE OF NORTH CAROLINA
DEPT. OF TRANSPORTATION
DIVISION OF HIGHWAYS
RALEIGH, N.C.

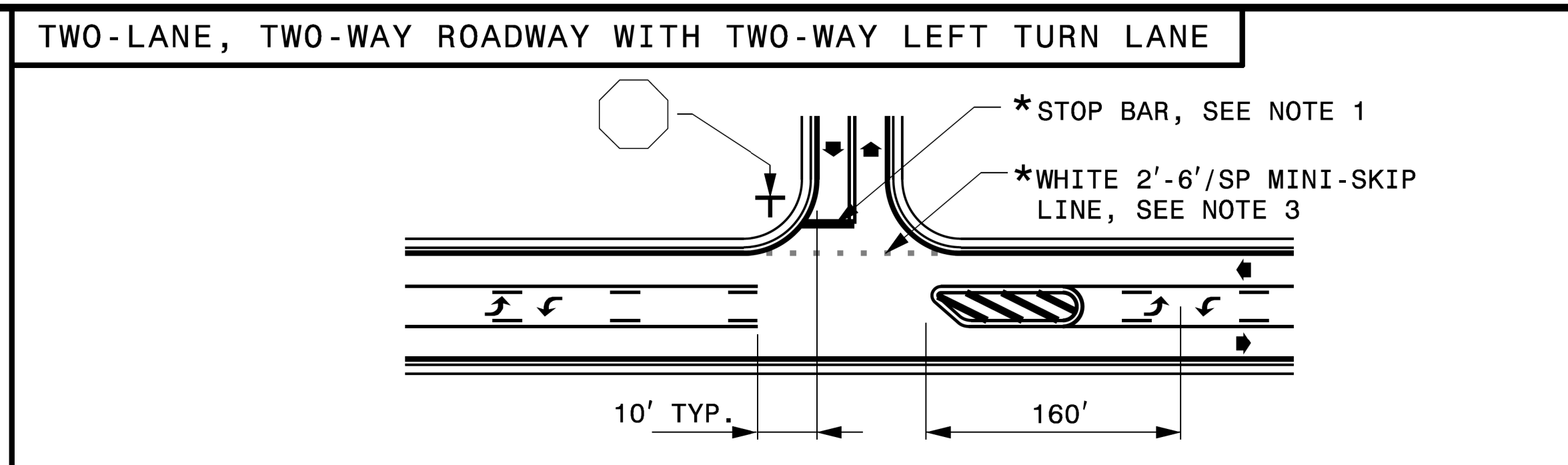
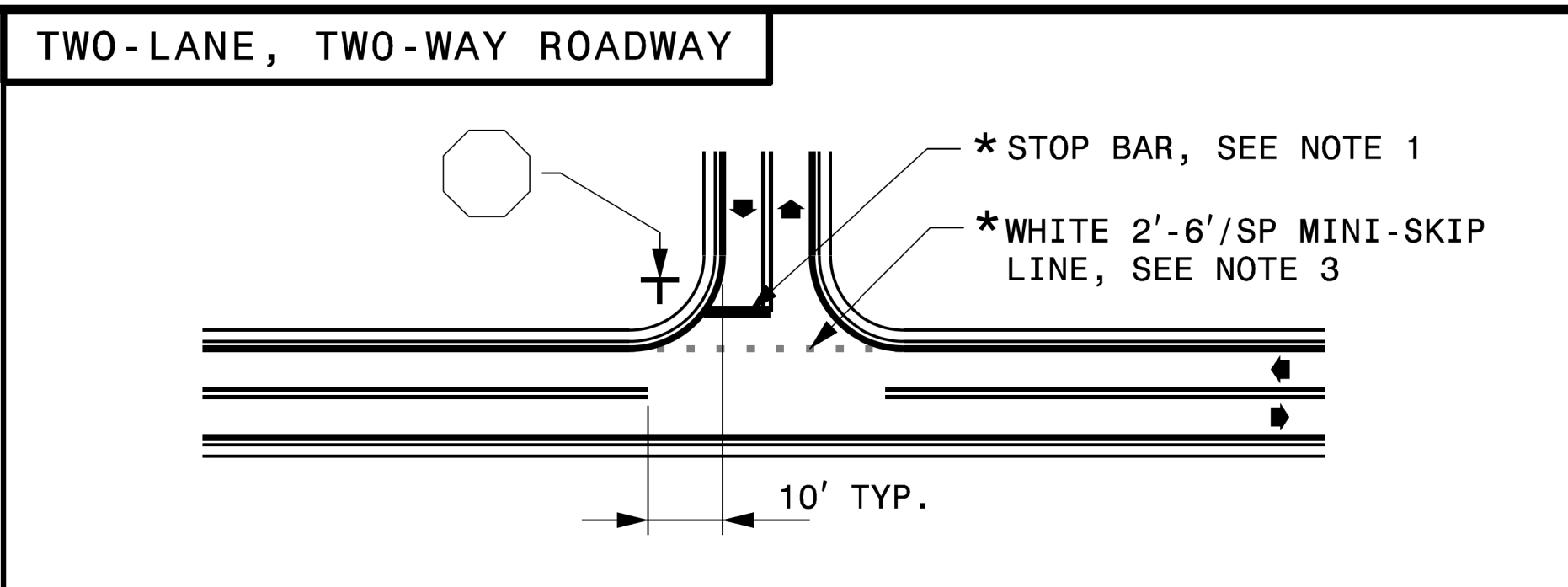

STATE OF NORTH CAROLINA
DEPT. OF TRANSPORTATION
DIVISION OF HIGHWAYS
RALEIGH, N.C.

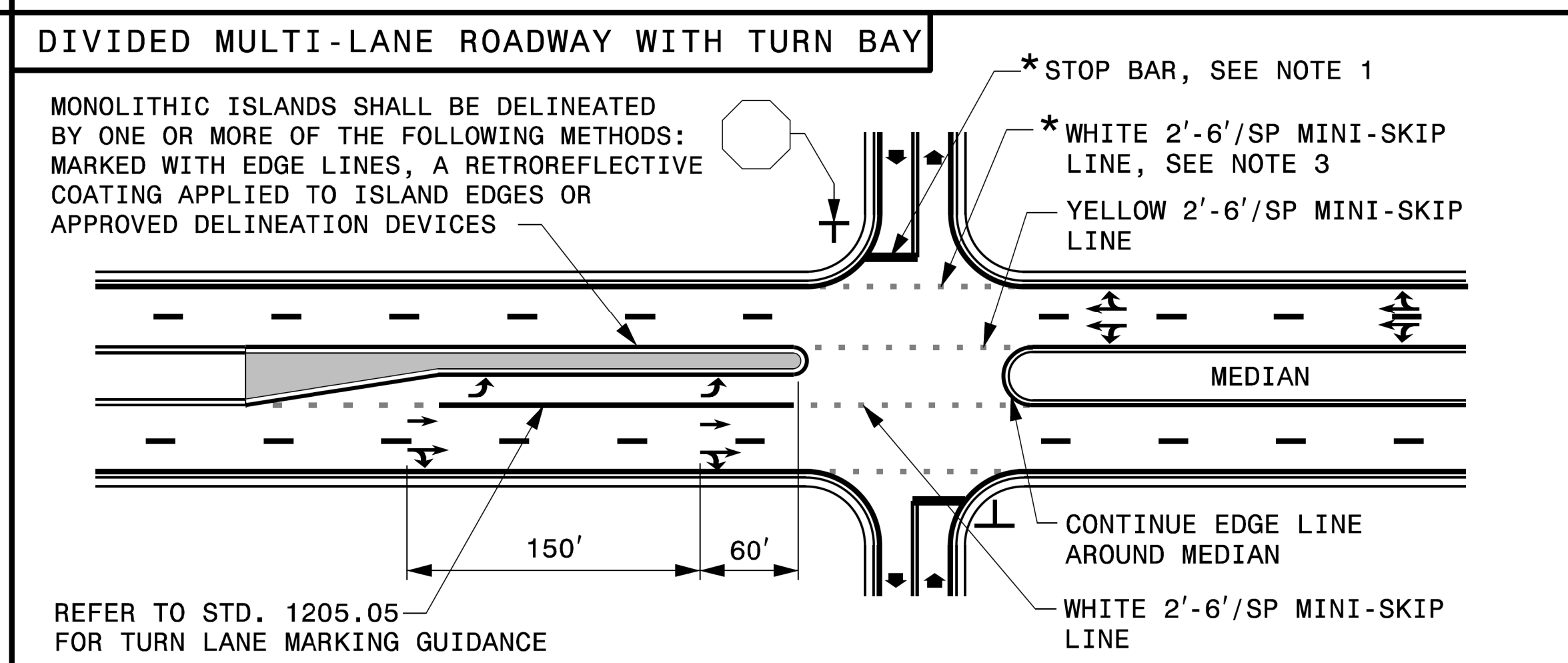
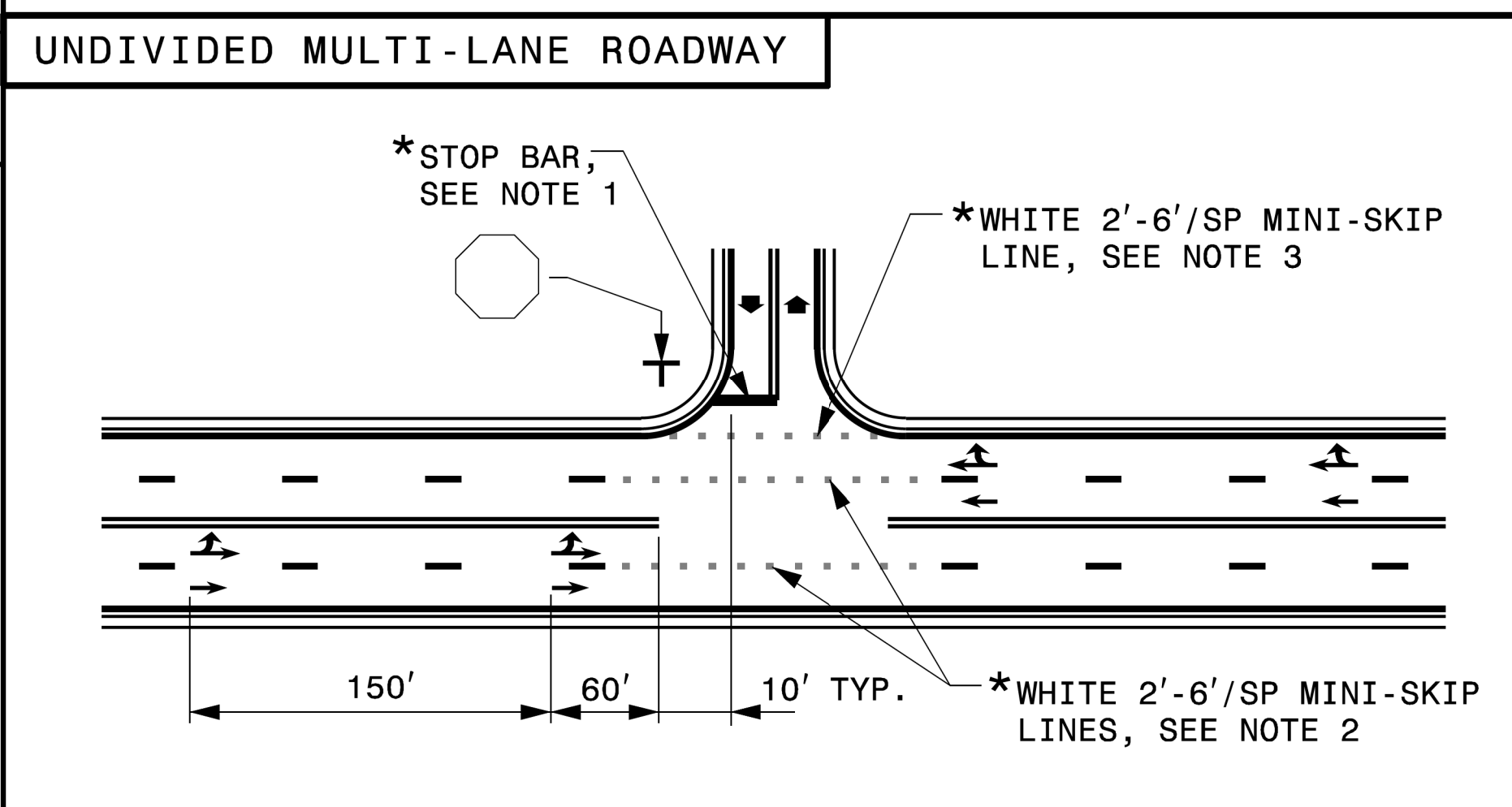



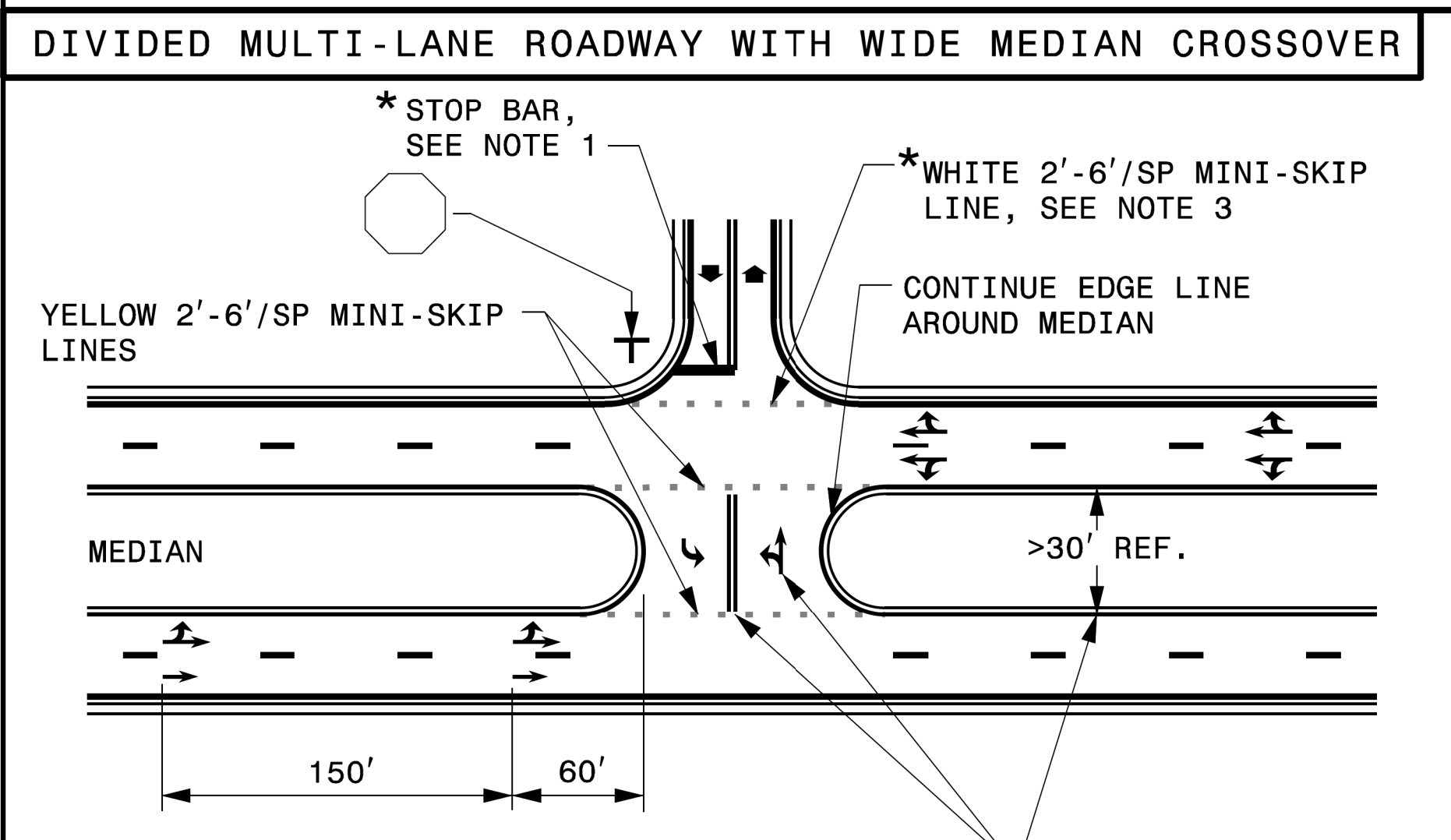

STATE OF NORTH CAROLINA
DEPT. OF TRANSPORTATION
DIVISION OF HIGHWAYS
RALEIGH, N.C.



GENERAL NOTES:

- 1- PLACEMENT OF STOP BARS AT NON-SIGNALIZED INTERSECTIONS IS OPTIONAL AND USED WHERE IT IS IMPORTANT TO INDICATE THE POINT WHICH VEHICLES ARE REQUIRED TO STOP. PLACE STOP BARS NO LESS THAN 4 FEET AND NO MORE THAN 30 FEET FROM THE NEAREST EDGE OF THE INTERSECTING ROADWAY. USE 10 FEET AS THE TYPICAL SETBACK DISTANCE OR AS DIRECTED BY THE ENGINEER.
- 2- MINI-SKIP LANE EXTENSIONS SHOULD BE USED AT INTERSECTIONS THAT HAVE REDUCED VISIBILITY CONDITIONS SUCH AS OFFSET, SKEWED, OR CURVED ROADWAYS.
- 3- MINI-SKIP EDGE LINE EXTENSIONS MAY BE PLACED THROUGH INTERSECTIONS AND MAJOR DRIVEWAYS.
- 4- REFER TO ROADWAY STANDARD DRAWINGS 1205.01, 1205.02, 1205.05, 1205.08 AND 1205.09 FOR ADDITIONAL PAVEMENT MARKING GUIDANCE.

| LEGEND | |
|---|---------------------------|
|  | STOP SIGN |
|  | STATIONARY SIGN |
|  | DIRECTION OF TRAFFIC FLOW |
|  | PAVEMENT MARKING SYMBOLS |
| * | OPTIONAL |

USE DOUBLE YELLOW CENTER LINE AND ARROW SYMBOLS IN MEDIAN CROSSOVER WHEN WIDTH OF MEDIAN EXCEEDS 30 FT, OTHERWISE THEY ARE NOT REQUIRED.

SHEET 2 OF 2
1205D04

SHEET 2 OF 2
1205D04

**REVISED PAVEMENT MARKING
ROADWAY STANDARD DRAWING**

APPROVED: _____
 DATE: _____

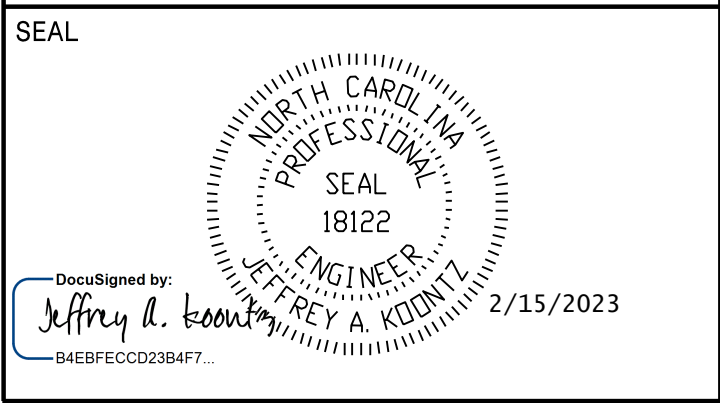

**DOCUMENT NOT CONSIDERED FINAL
UNLESS ALL SIGNATURES COMPLETED**

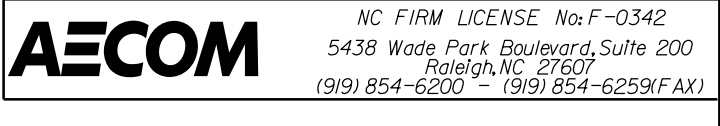

**FINAL PAVEMENT
MARKING SCHEDULE**

| SYMBOL | DESCRIPTION |
|----------------------|---|
| POLYUREA | |
| V1 | WHITE EDGELINE (4", 20 MIL) |
| V2 | WHITE SOLID LANE LINE (4", 20 MIL) |
| V3 | 10FT. WHITE SKIP (4", 20 MIL) |
| V4 | 3 FT. - 9 FT. /SP WHITE MINISKIP (4", 20 MIL) |
| V5 | 2 FT. - 6 FT. /SP WHITE MINISKIP (4", 20 MIL) |
| V10 | YELLOW EDGELINE (4", 20 MIL) |
| V11 | YELLOW SINGLE CENTER (4", 20 MIL) |
| V13 | YELLOW DOUBLE CENTER (4" 20 MIL) |
| V20 | WHITE EDGELINE (6", 20 MIL) |
| V22 | 10FT. WHITE SKIP (6", 20 MIL) |
| V30 | YELLOW EDGELINE (6", 20 MIL) |
| V43 | WHITE SOLID LANE LINE (8", 20 MIL) |
| V44 | 3 FT. - 9 FT. /SP WHITE MINISKIP (8", 20 MIL) |
| V50 | WHITE GORELINE (12", 20 MIL) |
| THERMOPLASTIC | |
| T61 | WHITE STOPBAR (24", 90 MIL) |
| T70 | LEFT TURN ARROW (90 MIL) |
| T71 | RIGHT TURN ARROW (90 MIL) |
| T72 | STRAIGHT ARROW (90 MIL) |
| T74 | COMBO. RIGHT/STRAIGHT ARROW (90 MIL) |
| T80 | WRONG-WAY RAMP ARROW (90 MIL) |
| T100 | ALPHANUMERIC CHAR. (90 MIL) |
| T103 | 24" YIELD LINE TRIANGLE (90 MIL) |

BEGIN PVT MARKING BR-0043
 -L- POT STA. 18+18 +/- WBL
 TIE TO EXISTING MARKINGS

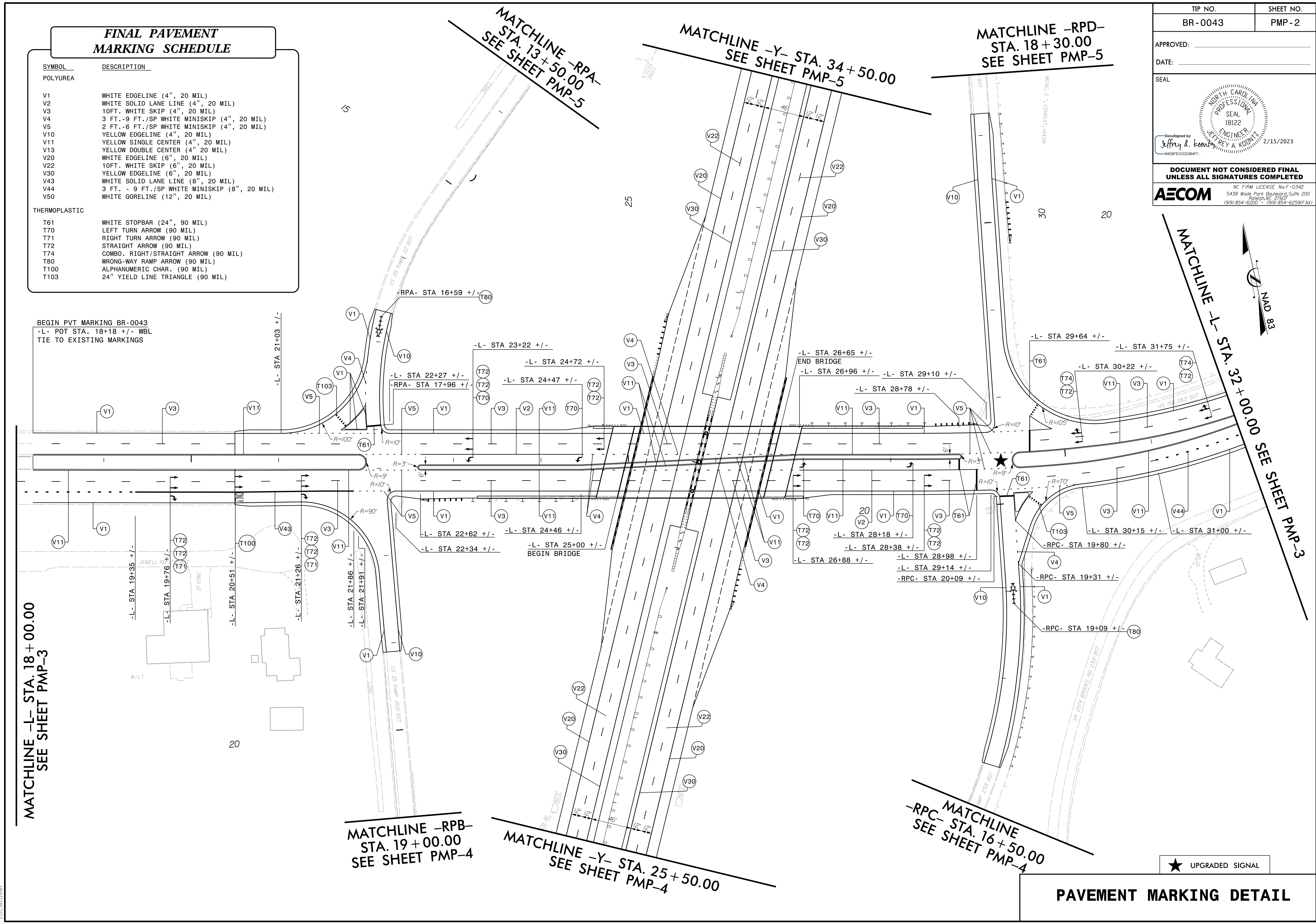

MATCHLINE -L- STA. 18+00.00
SEE SHEET PMP-3

MATCHLINE -RPB-
STA. 19+00.00
SEE SHEET PMP-4

MATCHLINE -Y- STA. 25+50.00
SEE SHEET PMP-4

MATCHLINE -Y- STA. 34+50.00
SEE SHEET PMP-5

MATCHLINE -RPD-
STA. 18+30.00
SEE SHEET PMP-5

MATCHLINE -L- STA. 32+00.00
SEE SHEET PMP-3

MATCHLINE
-RPC- STA. 16+50.00
SEE SHEET PMP-4



PAVEMENT MARKING DETAIL

2/13/2023 pvt\aecom-na-pw.bentley.com\AECOM_DS21_NA_2020\Documents\60581578-NCDDT_SMU_BR-0043\900-CAD_GIS\910-CAD\70-NCDDT_TIP\5\gimg and Delineation\PMP\BR0043_pmp_psh02.dgn localuser

2/13/2023
 p:\a\aecom-ne-pw\ben\jeffrey\com\AECOM_DS21_NA_2020\Documents\60581578-NCDDOT SMU BR-0043\900-CAD GIS\910-CAD\70-NCDDOT_TIP\Signing and Delineation\PM\BR0043_pmp_psh03.dgn
 localuser

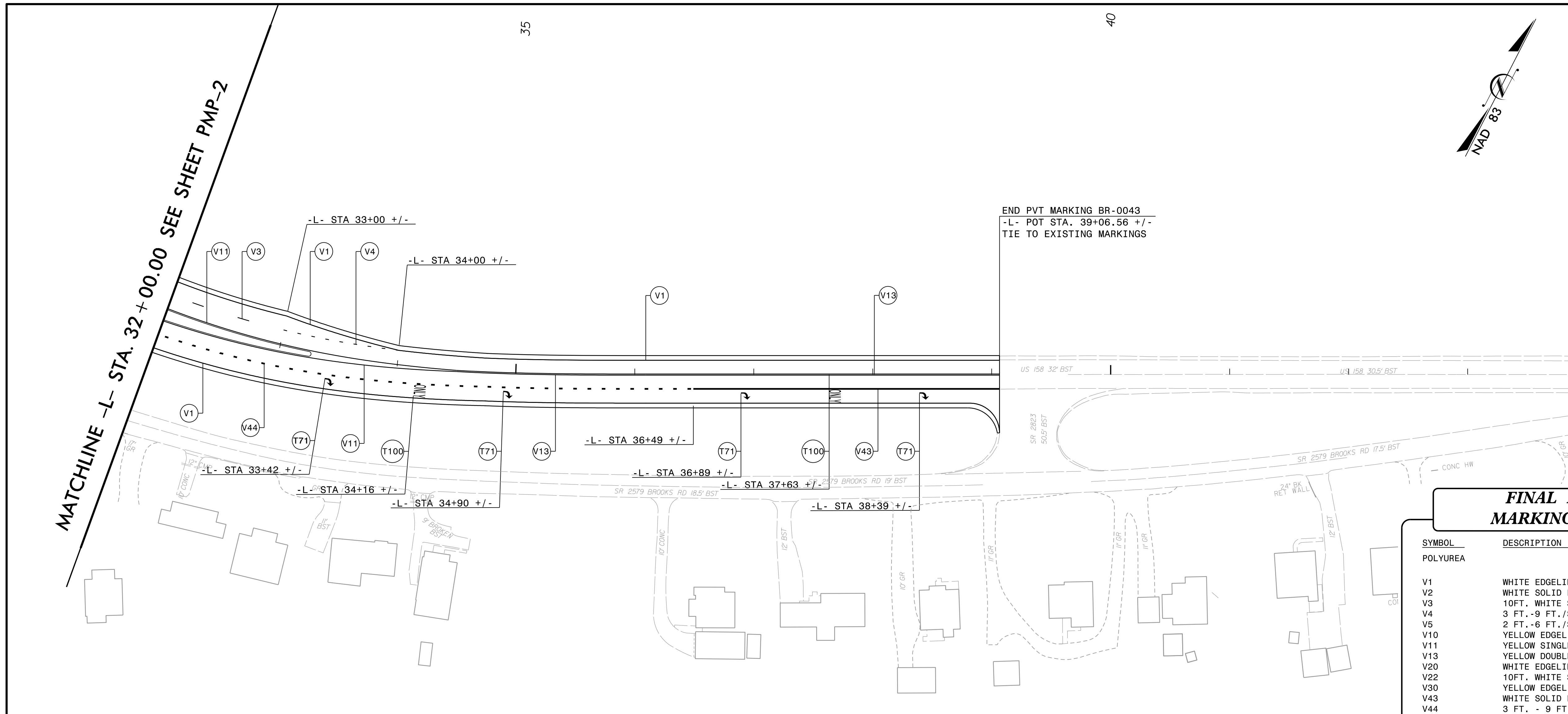

MATCHLINE -L- STA. 32 + 00.00 SEE SHEET PMP-2

END PVT MARKING BR-0043
 -L- POT STA. 39+06.56 +/-
 TIE TO EXISTING MARKINGS

| | |
|---|--------------------|
| TIP NO. BR-0043 | SHEET NO. PMP-3 |
| APPROVED: _____ | |
| DATE: _____ | |
| SEAL | |
| | |
| Documented by: Jeffrey A. Koonz 18122 2/15/2023 | |
| DOCUMENT NOT CONSIDERED FINAL UNLESS ALL SIGNATURES COMPLETED | |
| | |
| NC FIRM LICENSE No. F-0342 5438 Wade Park Boulevard, Suite 200 Raleigh, NC 27603 (919) 854-6200 • (919) 854-6259 (FAX) | |

FINAL PAVEMENT MARKING SCHEDULE

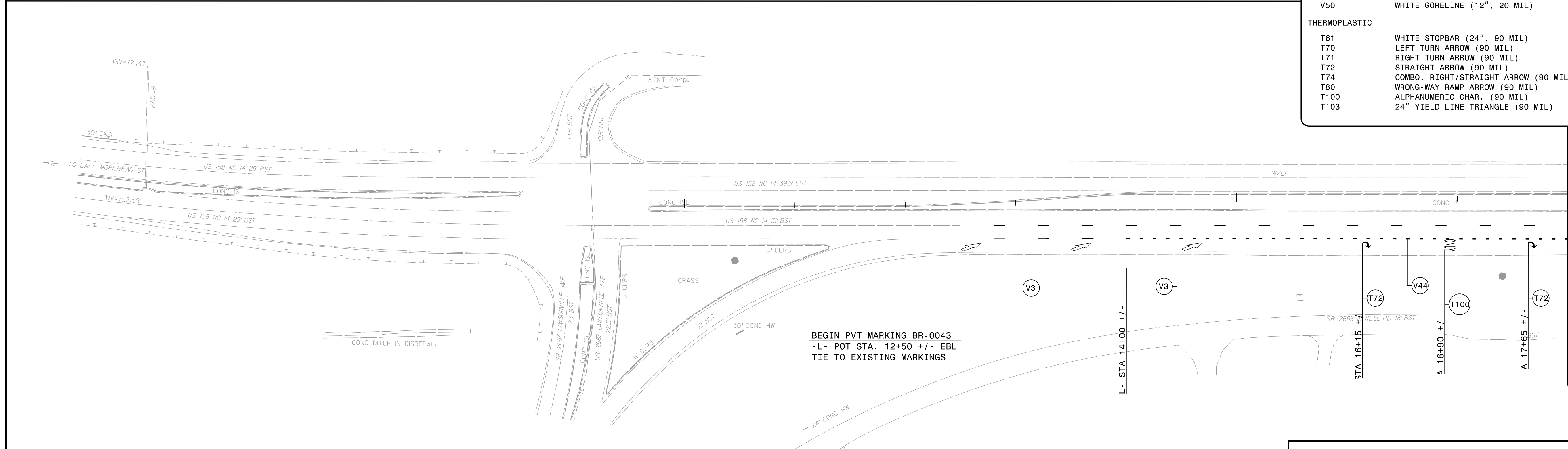

| SYMBOL | DESCRIPTION |
|----------------------|--|
| POLYUREA | |
| V1 | WHITE EDGELINE (4", 20 MIL) |
| V2 | WHITE SOLID LANE LINE (4", 20 MIL) |
| V3 | 10FT. WHITE SKIP (4", 20 MIL) |
| V4 | 3 FT.-9 FT./SP WHITE MINISKIP (4", 20 MIL) |
| V5 | 2 FT.-6 FT./SP WHITE MINISKIP (4", 20 MIL) |
| V10 | YELLOW EDGELINE (4", 20 MIL) |
| V11 | YELLOW SINGLE CENTER (4", 20 MIL) |
| V13 | YELLOW DOUBLE CENTER (4" 20 MIL) |
| V20 | WHITE EDGELINE (6", 20 MIL) |
| V22 | 10FT. WHITE SKIP (6", 20 MIL) |
| V30 | YELLOW EDGELINE (6", 20 MIL) |
| V43 | WHITE SOLID LANE LINE (8", 20 MIL) |
| V44 | 3 FT. - 9 FT./SP WHITE MINISKIP (8", 20 MIL) |
| V50 | WHITE GORELINE (12", 20 MIL) |
| THERMOPLASTIC | |
| T61 | WHITE STOPBAR (24", 90 MIL) |
| T70 | LEFT TURN ARROW (90 MIL) |
| T71 | RIGHT TURN ARROW (90 MIL) |
| T72 | STRAIGHT ARROW (90 MIL) |
| T74 | COMBO. RIGHT/STRAIGHT ARROW (90 MIL) |
| T80 | WRONG-WAY RAMP ARROW (90 MIL) |
| T100 | ALPHANUMERIC CHAR. (90 MIL) |
| T103 | 24" YIELD LINE TRIANGLE (90 MIL) |



BEGIN PVT MARKING BR-0043
 -L- POT STA. 12+50 +/- EBL
 TIE TO EXISTING MARKINGS

**MATCHLINE -L- STA. 18 + 00
SEE SHEET PMP-2**

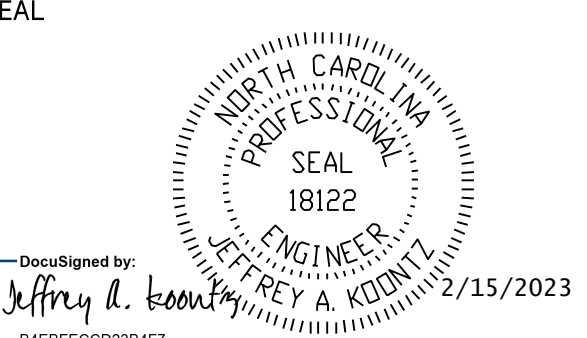
PAVEMENT MARKING DETAIL

| | |
|---|--------------------|
| TIP NO. BR-0043 | SHEET NO. PMP-4 |
| APPROVED: _____ | |
| DATE: _____ | |
| SEAL | |
|  | |
| Signed by: <u>Jeffrey A. Kiontz</u> 2/15/2023 <small>44E8FECC02384F7</small> | |
| DOCUMENT NOT CONSIDERED FINAL UNLESS ALL SIGNATURES COMPLETED | |
|  <small>NC FIRM LICENSE No. F-0342 5438 Wade Park Boulevard, Suite 200 Raleigh, NC 27604 (919) 854-6200 • (919) 854-6259 (FAX)</small> | |

FINAL PAVEMENT MARKING SCHEDULE

| SYMBOL | DESCRIPTION |
|----------------------|--|
| POLYUREA | |
| V1 | WHITE EDGELINE (4", 20 MIL) |
| V2 | WHITE SOLID LANE LINE (4", 20 MIL) |
| V3 | 10FT. WHITE SKIP (4", 20 MIL) |
| V4 | 3 FT.-9 FT./SP WHITE MINISKIP (4", 20 MIL) |
| V5 | 2 FT.-6 FT./SP WHITE MINISKIP (4", 20 MIL) |
| V10 | YELLOW EDGELINE (4", 20 MIL) |
| V11 | YELLOW SINGLE CENTER (4", 20 MIL) |
| V13 | YELLOW DOUBLE CENTER (4" 20 MIL) |
| V20 | WHITE EDGELINE (6", 20 MIL) |
| V22 | 10FT. WHITE SKIP (6", 20 MIL) |
| V30 | YELLOW EDGELINE (6", 20 MIL) |
| V43 | WHITE SOLID LANE LINE (8", 20 MIL) |
| V44 | 3 FT. - 9 FT./SP WHITE MINISKIP (8", 20 MIL) |
| V50 | WHITE GORELINE (12", 20 MIL) |
| THERMOPLASTIC | |
| T61 | WHITE STOPBAR (24", 90 MIL) |
| T70 | LEFT TURN ARROW (90 MIL) |
| T71 | RIGHT TURN ARROW (90 MIL) |
| T72 | STRAIGHT ARROW (90 MIL) |
| T74 | COMBO. RIGHT/STRAIGHT ARROW (90 MIL) |
| T80 | WRONG-WAY RAMP ARROW (90 MIL) |
| T100 | ALPHANUMERIC CHAR. (90 MIL) |
| T103 | 24" YIELD LINE TRIANGLE (90 MIL) |



**MATCHLINE -RPB-
STA. 19+00.00
SEE SHEET PMP-2**

**MATCHLINE -Y- STA. 25+50.00
SEE SHEET PMP-2**

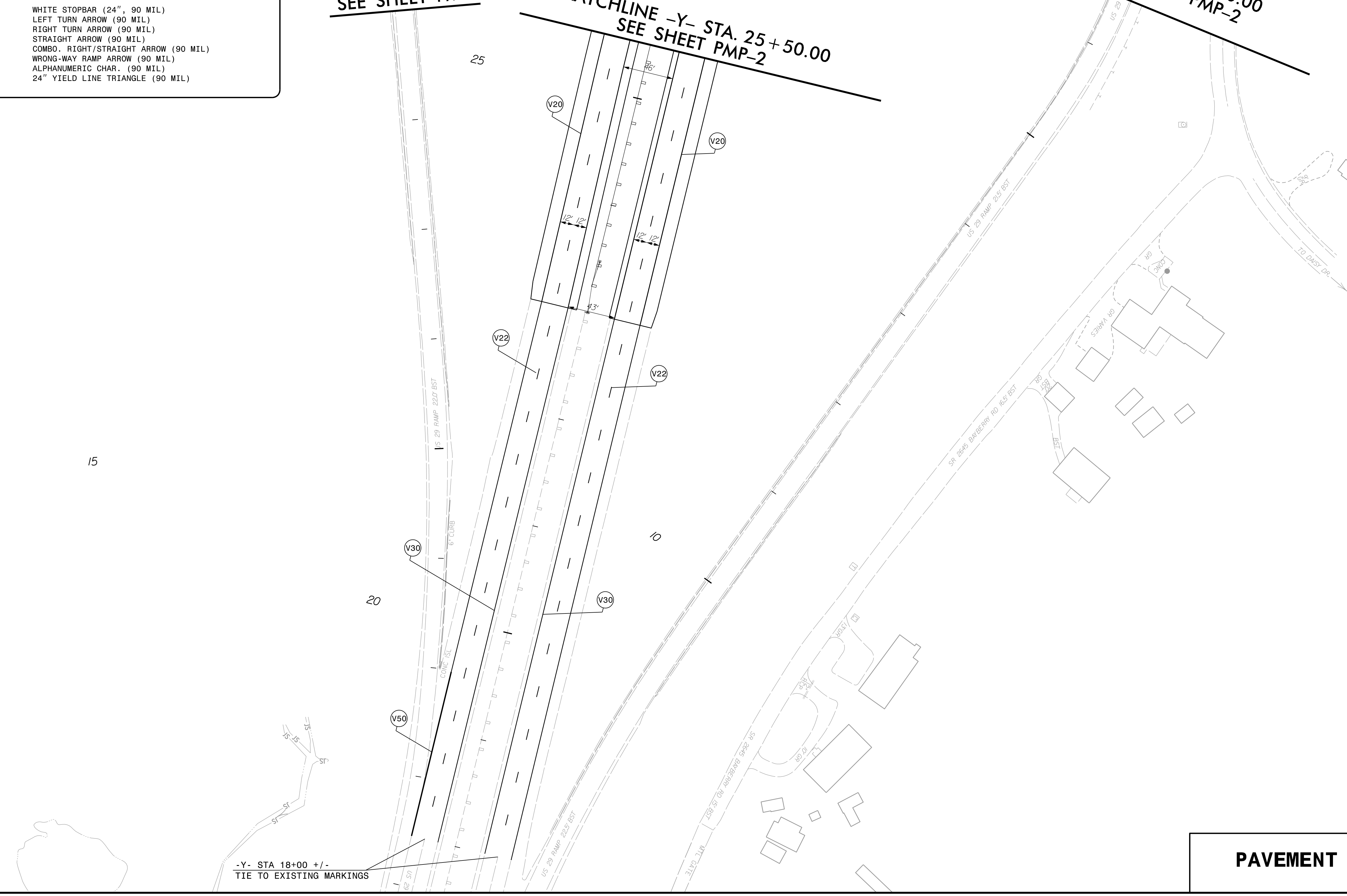

**MATCHLINE -RPC-
STA. 16+50.00
SEE SHEET PMP-2**

2/13/2023 p:\a\aecom-ne-pw\ben\jeffrey.com\AECOM_DS21_NA_2020\Documents\60581578-NCDDOT SMU BR-0043\900-CAD GIS\910-CAD\70-NCDDOT_TIP\5\gimg and Delineation\PM\BR0043.pmp_psh04.dgn localuser

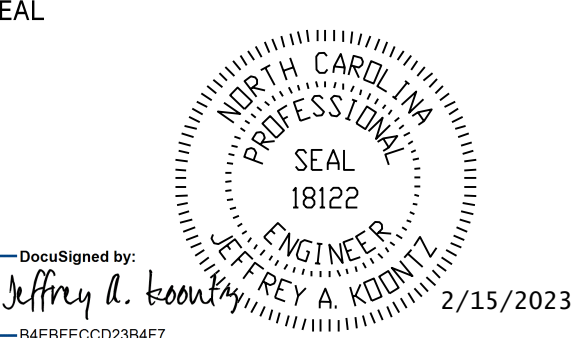

-Y- STA 18+00 +/-
TIE TO EXISTING MARKINGS

PAVEMENT MARKING DETAIL

| | |
|---|--------------------|
| TIP NO. BR-0043 | SHEET NO. PMP-5 |
| APPROVED: _____ | |
| DATE: _____ | |
| SEAL | |
|  | |
| Signed by: <i>Jeffrey A. Koonz</i> 2/15/2023 <small>48EFEC02284F7...</small> | |
| DOCUMENT NOT CONSIDERED FINAL UNLESS ALL SIGNATURES COMPLETED | |
|  <small>NC FIRM LICENSE No. F-0342 5438 Wade Park Boulevard, Suite 200 Raleigh, NC 27604 (919) 854-6200 • (919) 854-6259 (FAX)</small> | |

| FINAL PAVEMENT MARKING SCHEDULE | |
|--|--|
| SYMBOL | DESCRIPTION |
| POLYUREA | |
| V1 | WHITE EDGELINE (4", 20 MIL) |
| V2 | WHITE SOLID LANE LINE (4", 20 MIL) |
| V3 | 10FT. WHITE SKIP (4", 20 MIL) |
| V4 | 3 FT.-9 FT./SP WHITE MINISKIP (4", 20 MIL) |
| V5 | 2 FT.-6 FT./SP WHITE MINISKIP (4", 20 MIL) |
| V10 | YELLOW EDGELINE (4", 20 MIL) |
| V11 | YELLOW SINGLE CENTER (4", 20 MIL) |
| V13 | YELLOW DOUBLE CENTER (4" 20 MIL) |
| V20 | WHITE EDGELINE (6", 20 MIL) |
| V22 | 10FT. WHITE SKIP (6", 20 MIL) |
| V30 | YELLOW EDGELINE (6", 20 MIL) |
| V43 | WHITE SOLID LANE LINE (8", 20 MIL) |
| V44 | 3 FT. - 9 FT./SP WHITE MINISKIP (8", 20 MIL) |
| V50 | WHITE GORELINE (12", 20 MIL) |
| THERMOPLASTIC | |
| T61 | WHITE STOPBAR (24", 90 MIL) |
| T70 | LEFT TURN ARROW (90 MIL) |
| T71 | RIGHT TURN ARROW (90 MIL) |
| T72 | STRAIGHT ARROW (90 MIL) |
| T74 | COMBO. RIGHT/STRAIGHT ARROW (90 MIL) |
| T80 | WRONG-WAY RAMP ARROW (90 MIL) |
| T100 | ALPHANUMERIC CHAR. (90 MIL) |
| T103 | 24" YIELD LINE TRIANGLE (90 MIL) |

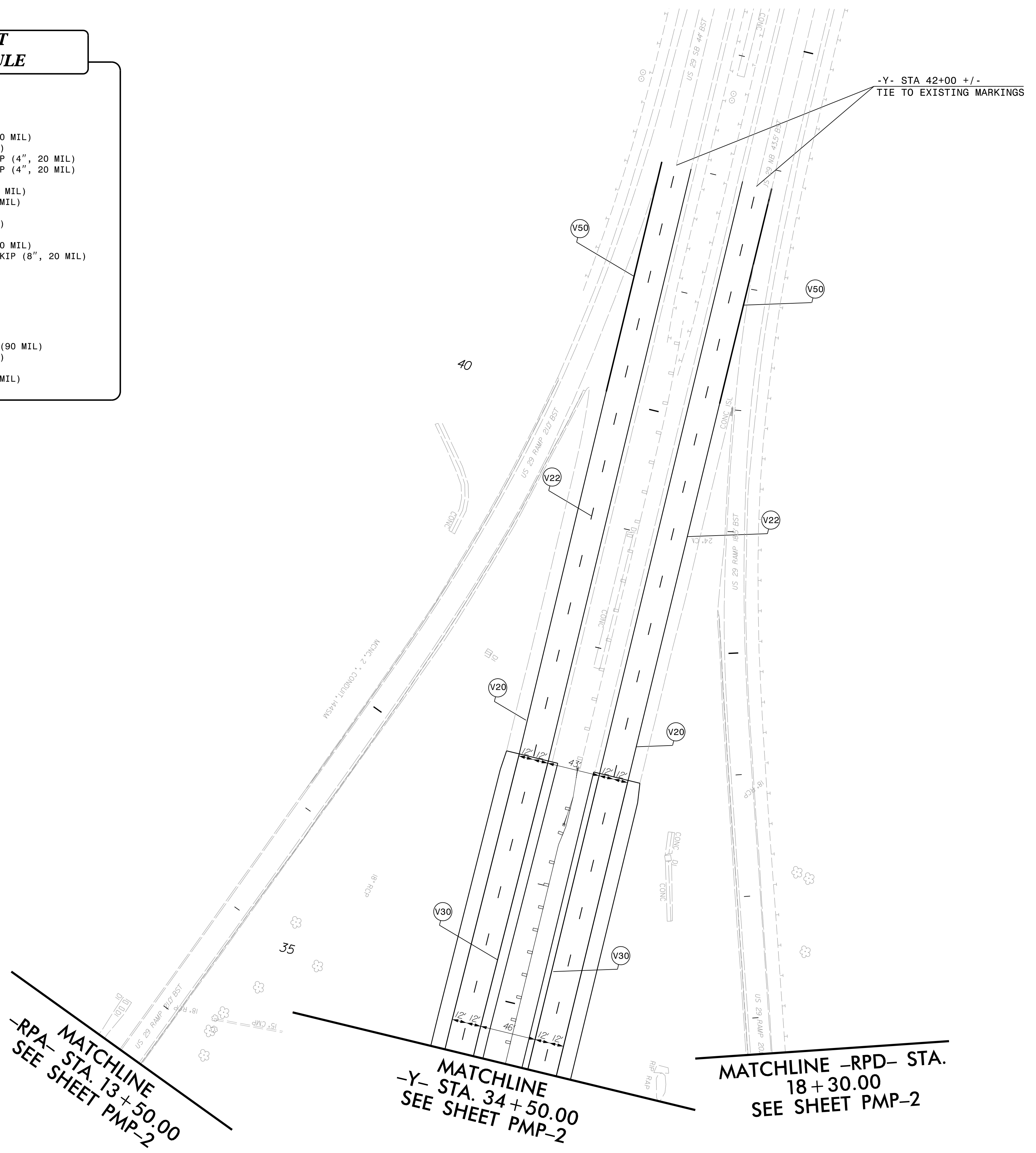

10

15

PAVEMENT MARKING DETAIL

2/13/2023
 pvt\aecom-ne-pw.bentley.com\AECOM_DS21_NA_2020\Documents\60581578-NCDDT SMU BR-0043\900-CAD GIS\910-CAD\70-NCDDT_TIP\5.igmg and Delineation\PMP\BR0043.pmp_psh05.dgn
 localuser