

SECTION A-A

*INVERT ALTERNATE PAIR OF STIRRUPS

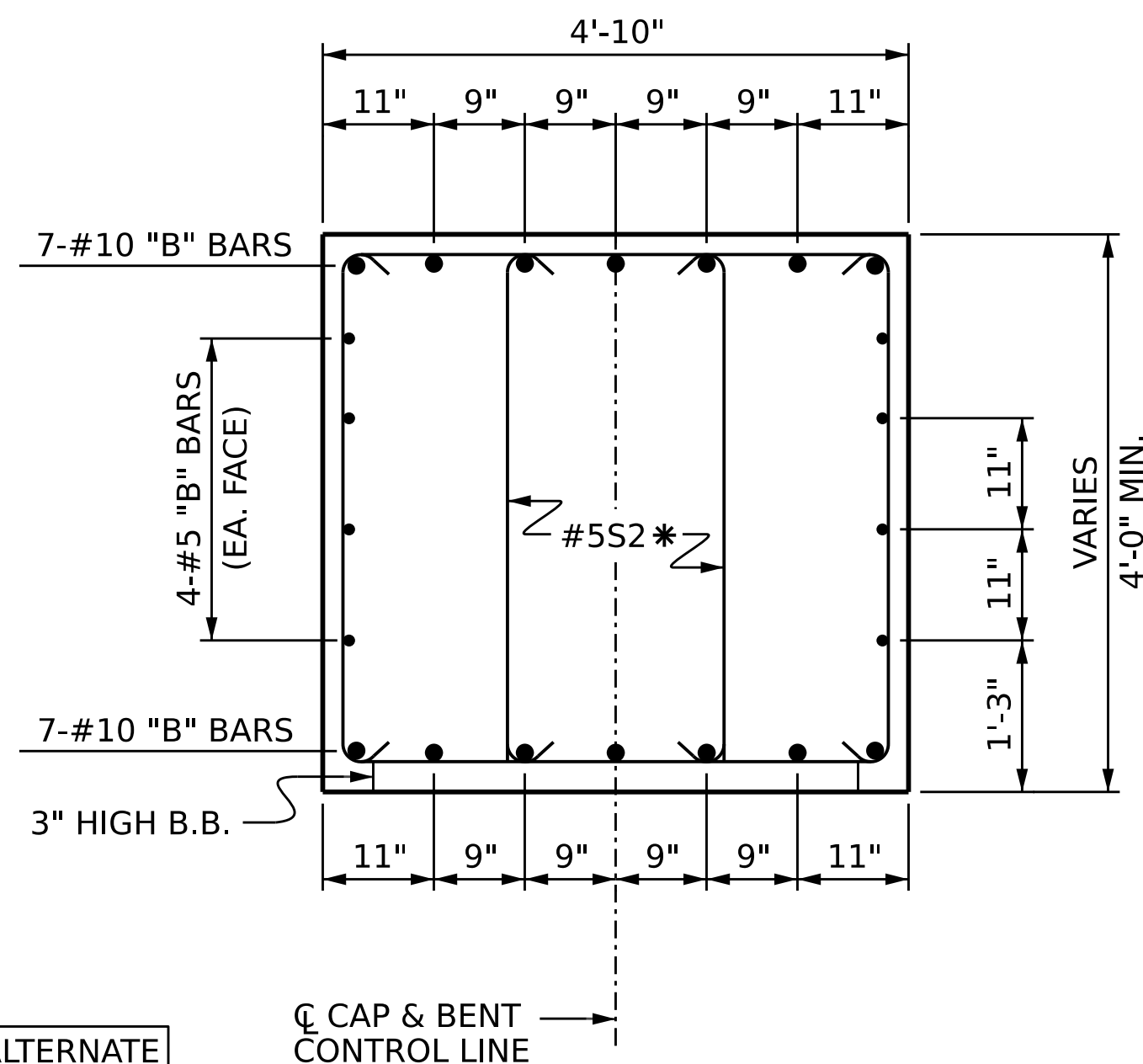

SECTION B-B

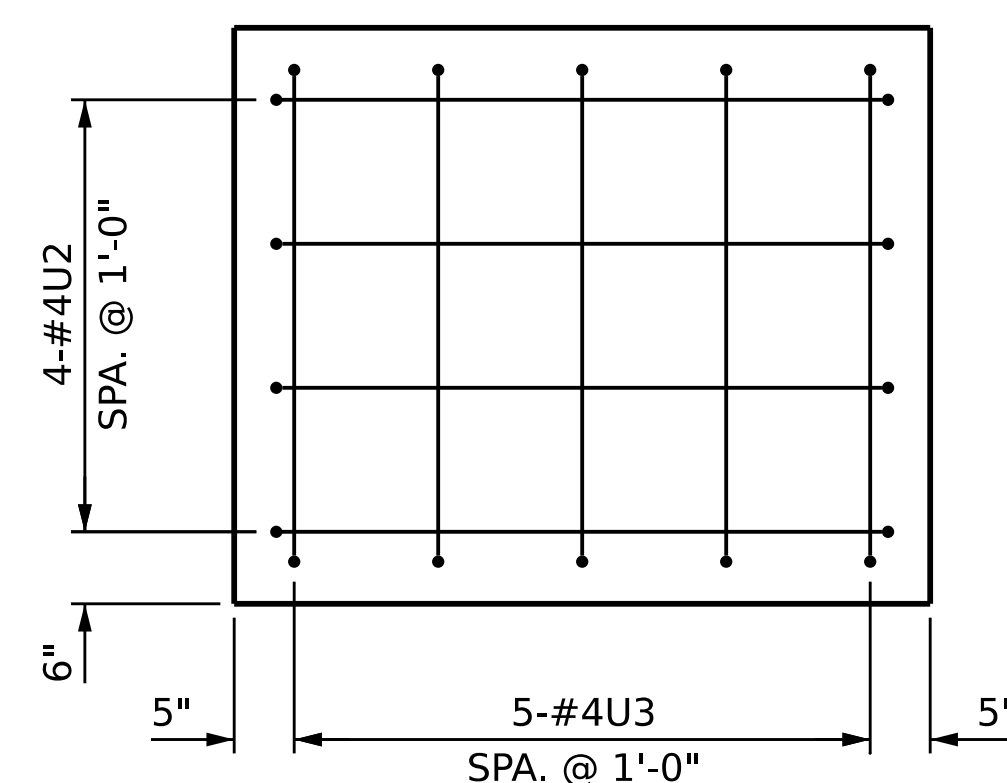

CAP END VIEW

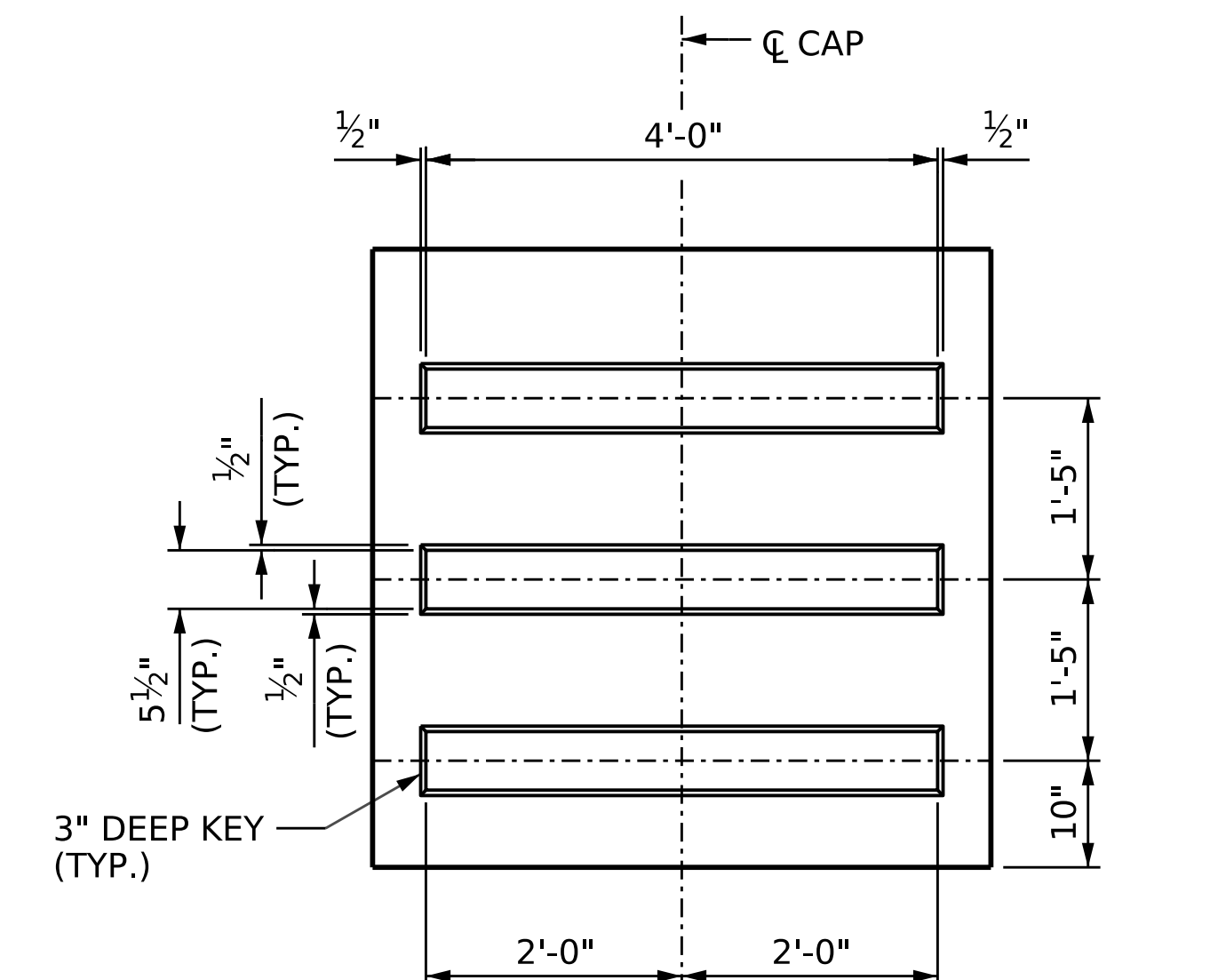

SECTION X-X

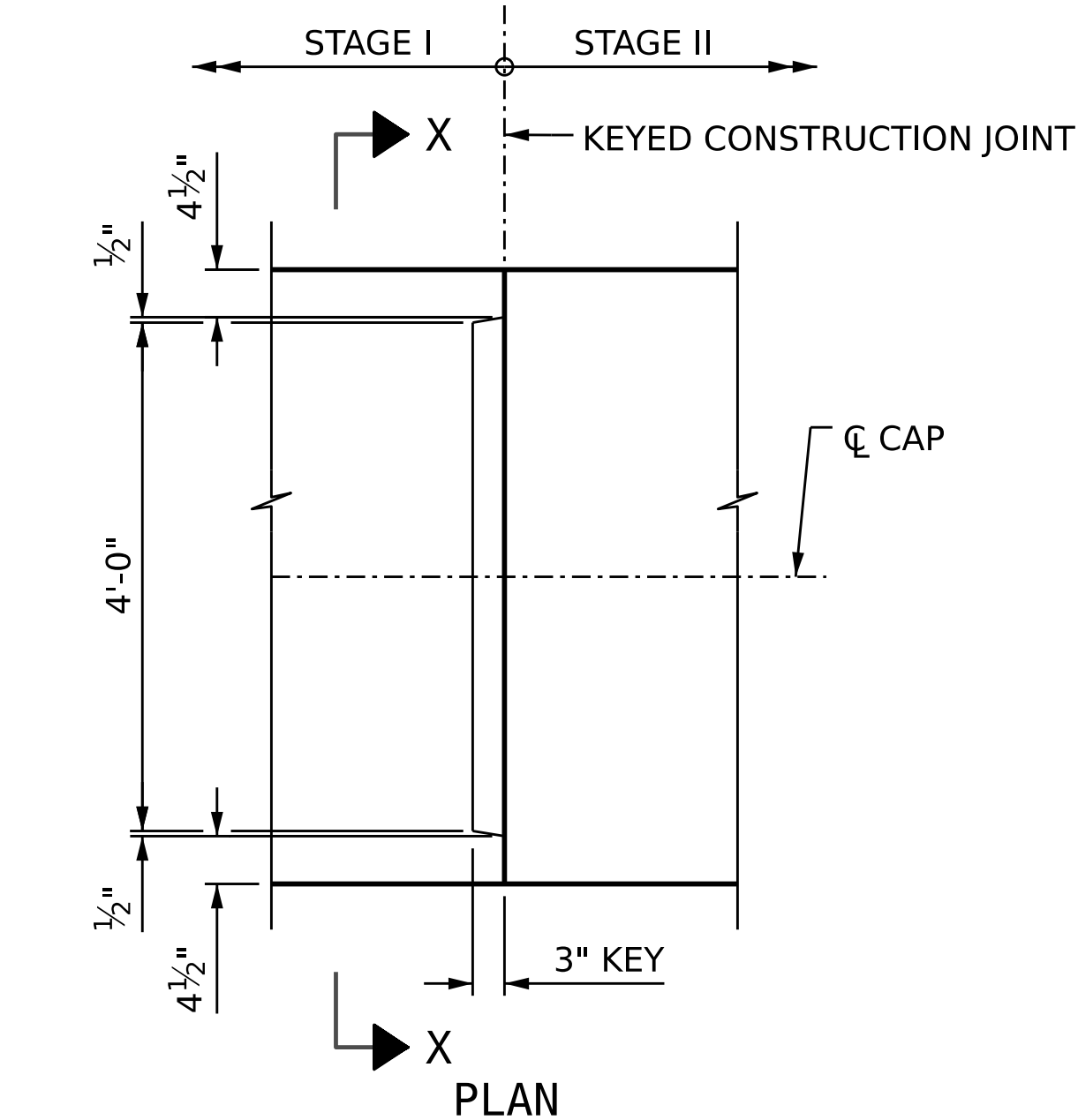

PLAN

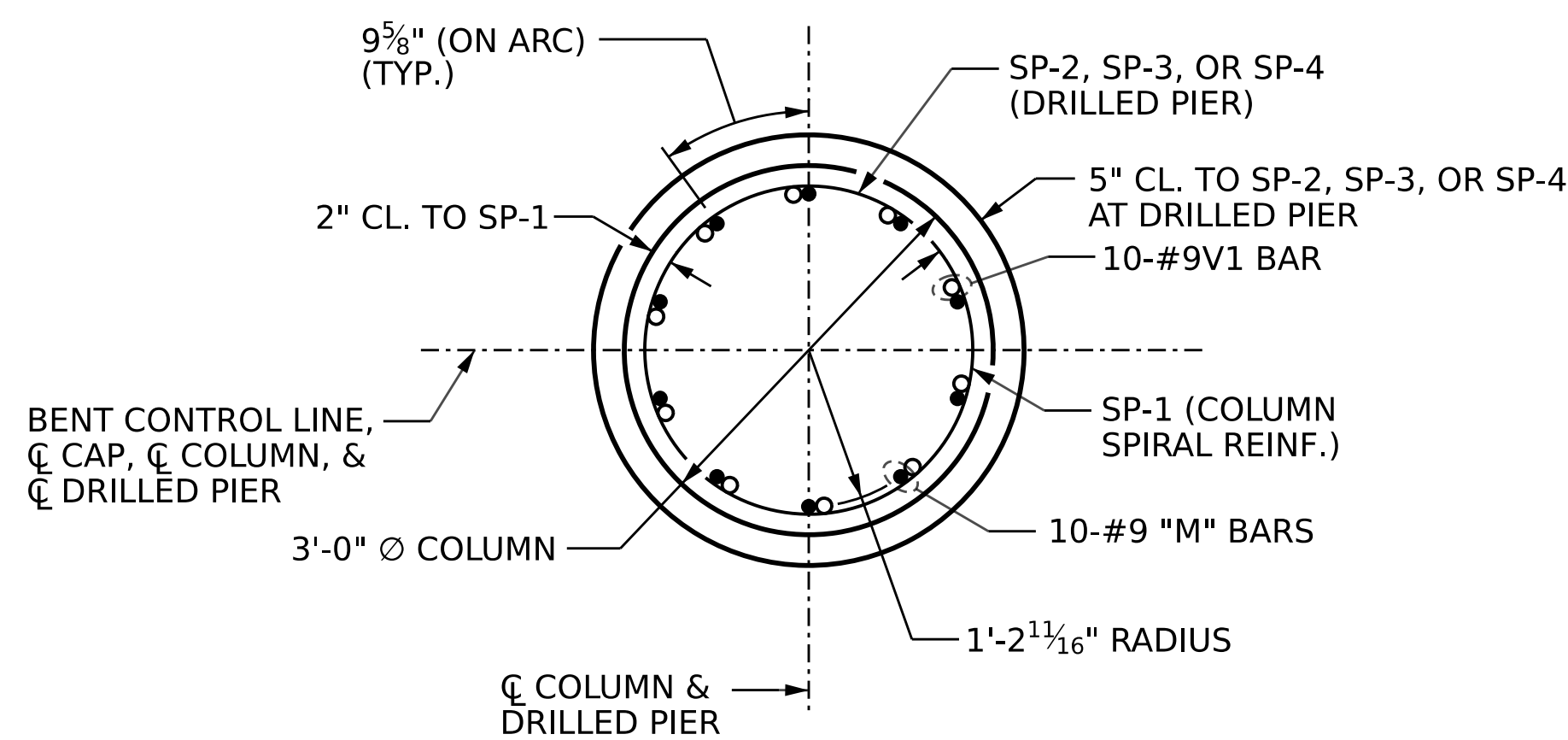

SECTION THRU COLUMN & DRILLED PIER

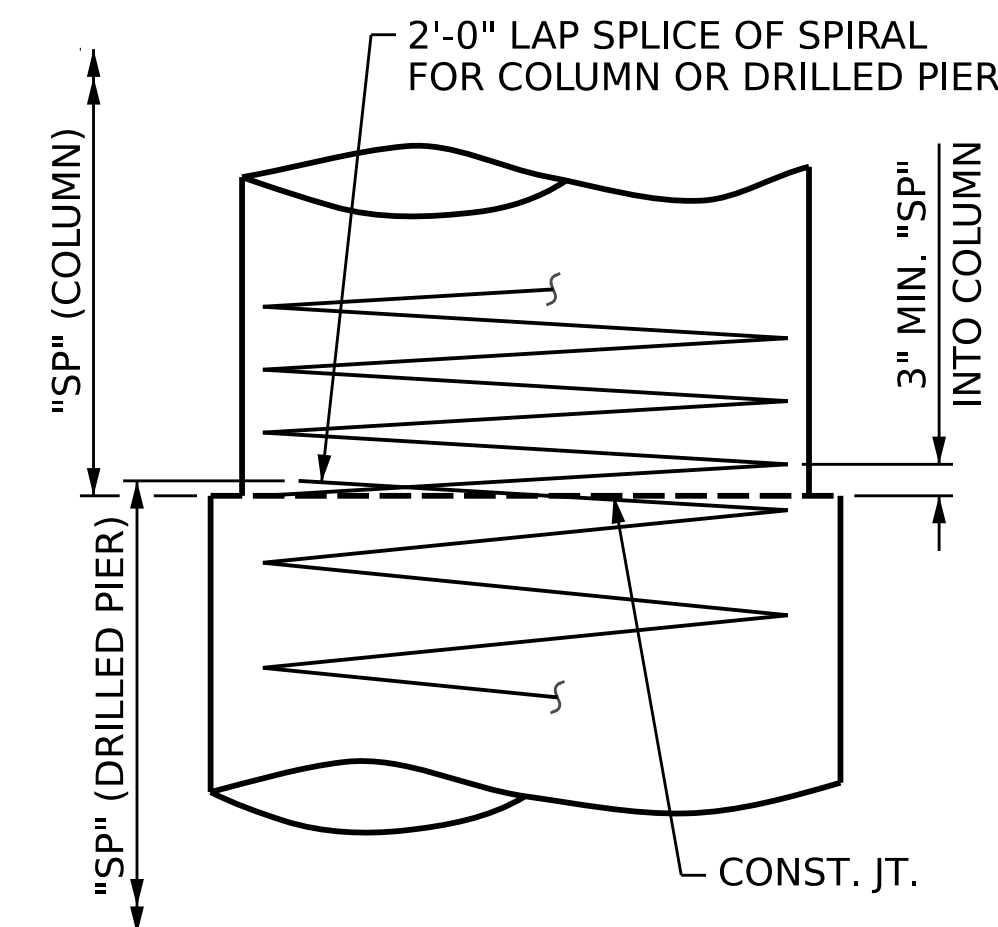

CONSTRUCTION JOINT DETAIL

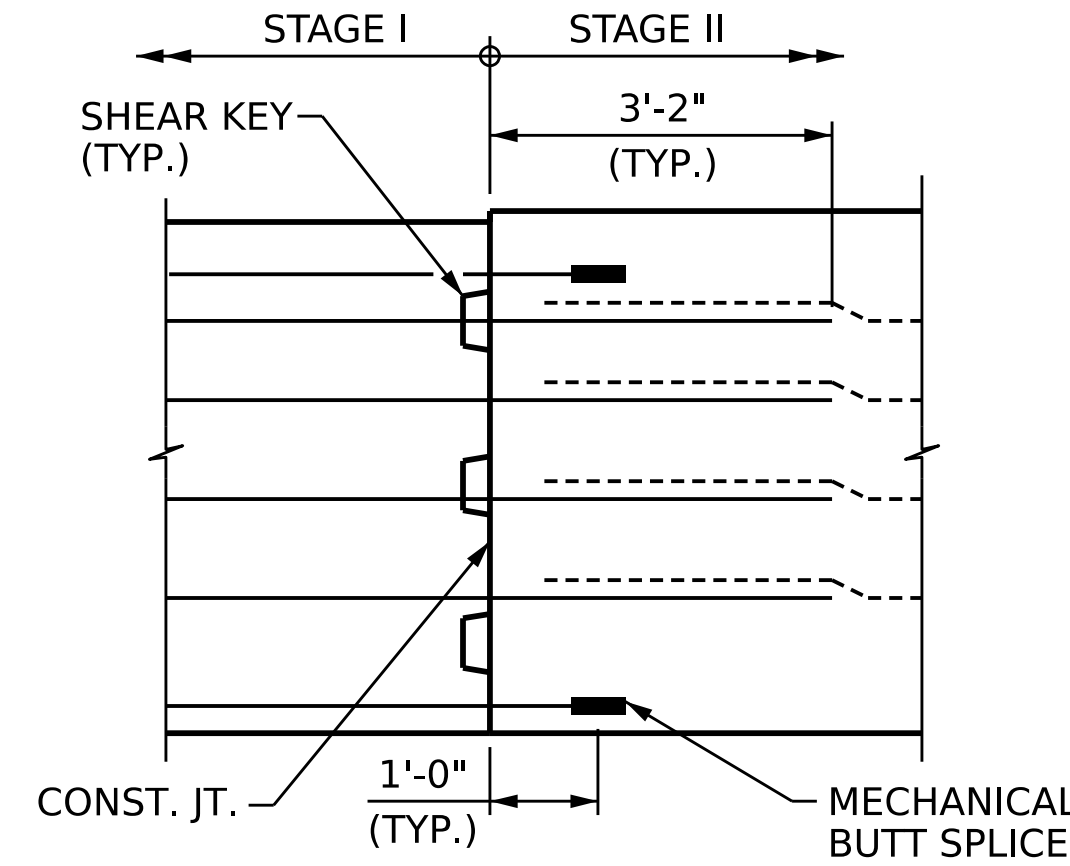

DETAIL "B"

KEYED CONSTRUCTION JOINT DETAIL

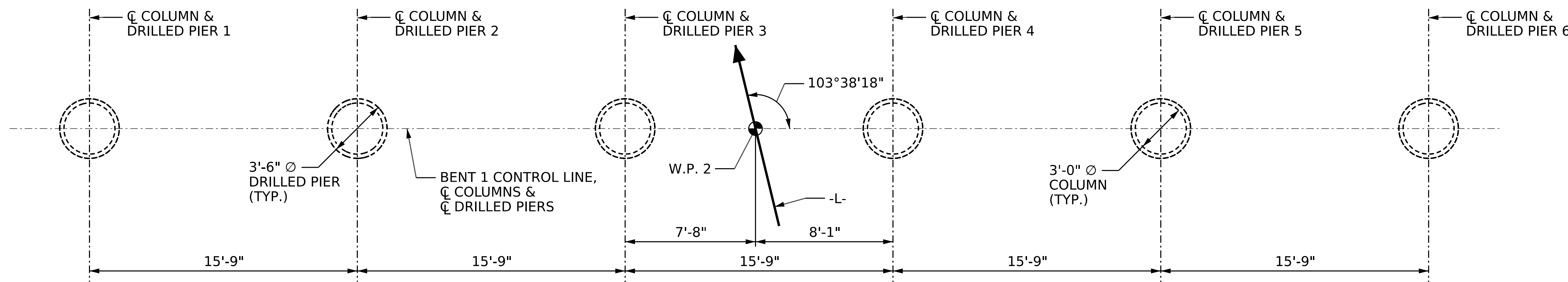

PLAN OF DRILLED PIERS AND COLUMNS

PROJECT NO. BR-0043
ROCKINGHAM COUNTY
 STATION: POT 25+80.88 -L-
 SHEET 3 OF 4

AECOM
 AECOM TECHNICAL SERVICES OF NC, INC.
 5430 WADE PARK BOULEVARD, SUITE 200
 RALEIGH, NC 27607
 (919) 854-6200 www.aecom.com
 AECOM License No. F0242

DocuSigned by:
 John C. Morrison 1/31/2023
 A2FDE142C82F44B...

STATE OF NORTH CAROLINA DEPARTMENT OF TRANSPORTATION RALEIGH					
SUBSTRUCTURE BENT 1					
REVISIONS					
NO.	BY:	DATE:	NO.	BY:	DATE:
1			3		
2			4		
SHEET NO.					S-35
TOTAL SHEETS					45

DRAWN BY: D.R. DRUM DATE: 11/2022
 CHECKED BY: D. RITACCO DATE: 11/2022
 DESIGN ENGINEER OF RECORD: J.C. MORRISON DATE: 12/2022

DOCUMENT NOT CONSIDERED
 FINAL UNLESS ALL
 SIGNATURES COMPLETED