

TIP NO.	SHEET NO.
BR-0041	PMP-1
APPROVED: <i>Jeffrey A. Koontz</i>	DocuSigned by: Jeffrey A. Koontz
DATE: 2/15/2023	RECORDED: 2/15/2023
SEAL	
DOCUMENT NOT CONSIDERED FINAL UNLESS ALL SIGNATURES COMPLETED	

**STATE OF NORTH CAROLINA
DEPARTMENT OF TRANSPORTATION**

**PAVEMENT MARKING PLAN
ROCKINGHAM COUNTY**

**LOCATION: BRIDGE 780001 ON SR 2817 (BARNES ST)
OVER OVER US 29**

T.I.P.: BR-0041

INDEX

SHEET NO.	DESCRIPTION
PMP-1	PAVEMENT MARKING PLAN TITLE AND SCHEDULE SHEET
PMP-1A	PAVEMENT MARKING SPECIAL DETAIL
PMP-2 THRU PMP-4	PAVEMENT MARKING DETAILS

**FINAL PAVEMENT
MARKING SCHEDULE**

SYMBOL	DESCRIPTION	SYMBOL	DESCRIPTION
POLYUREA		THERMOPLASTIC	
V1	WHITE EDGELINE (4", 20 MIL)	T61	WHITE STOPBAR (24", 90 MIL)
V2	WHITE SOLID LANE LINE (4", 20 MIL)	T70	LEFT TURN ARROW (90 MIL)
V3	10FT. WHITE SKIP (4", 90 MIL)	T71	RIGHT TURN ARROW (90 MIL)
V4	3 FT.-9 FT./SP WHITE MINISKIP (4", 20 MIL)	T72	STRAIGHT ARROW (90 MIL)
V5	2 FT.-6 FT./SP WHITE MINISKIP (4", 20 MIL)	T73	COMBO. LEFT/STRAIGHT ARROW (90 MIL)
V10	YELLOW EDGELINE (4", 20 MIL)	T74	COMBO. RIGHT/STRAIGHT ARROW (90 MIL)
V11	YELLOW SINGLE CENTER (4", 20 MIL)	T79	MERGE ARROW (90 MIL)
V12	10 FT. YELLOW SKIP (4", 20 MIL)	T80	WRONG-WAY RAMP ARROW (90 MIL)
V13	YELLOW DOUBLE CENTER (4" 20 MIL)	T103	24" YIELD LINE TRIANGLE (90 MIL)
V20	WHITE EDGELINE (6", 20 MIL)		
V22	10FT. WHITE SKIP (6", 20 MIL)		
V30	YELLOW EDGELINE (6", 20 MIL)		
V50	WHITE GORELINE (12", 20 MIL)		

GENERAL NOTES

THE FOLLOWING GENERAL NOTES APPLY AT ALL TIMES FOR THE DURATION OF THE CONSTRUCTION PROJECT, EXCEPT WHEN OTHERWISE NOTED IN THE PLAN, OR DIRECTED BY THE ENGINEER.

A) INSTALL PAVEMENT MARKINGS AND PAVEMENT MARKERS ON THE FINAL SURFACE AS FOLLOWS:

ROAD NAME	MARKING	MARKER
BARNES STREET	POLYUREA	SNOWPLOWABLE
BARNES STREET (BRIDGE)	POLYUREA	RAISED
US 29	POLYUREA	SNOWPLOWABLE
US 29 RAMPS	POLYUREA	SNOWPLOWABLE
WATLINGTON INDUSTRIAL DR	POLYUREA	SNOWPLOWABLE

B) TIE PROPOSED PAVEMENT MARKING LINES TO EXISTING PAVEMENT MARKING LINES.

C) REMOVE/REPLACE ANY CONFLICTING/DAMAGED PAVEMENT MARKINGS AND MARKERS.

D) STOP BAR LOCATION AT NON-SIGNALIZED INTERSECTIONS MAY BE ADJUSTED AS DIRECTED BY THE ENGINEER.

E) UNLESS OTHERWISE SPECIFIED, HEATED-IN-PLACE THERMOPLASTIC MAY BE USED IN LIEU OF EXTRUDED THERMOPLASTIC FOR STOP BARS, SYMBOLS, CHARACTERS AND DIAGONALS. IF HEATED-IN-PLACE IS USED, IT SHALL BE PAID FOR USING THE EXTRUDED THERMOPLASTIC PAY ITEM.

ROADWAY STANDARD DRAWING

THE FOLLOWING ROADWAY STANDARDS AS APPEAR IN "ROADWAY STANDARD DRAWINGS" - PROJECT SERVICES UNIT - N.C. DEPARTMENT OF TRANSPORTATION - RALEIGH, N.C., DATED JANUARY 2018 ARE APPLICABLE TO THIS PROJECT AND BY REFERENCE HEREBY ARE CONSIDERED A PART OF THESE PLANS:

STD. NO.	TITLE
1205.01	PAVEMENT MARKINGS - LINE TYPES AND OFFSETS
1205.02	PAVEMENT MARKINGS - TWO-LANE AND MULTILANE ROADWAYS
1205.04	PAVEMENT MARKINGS - INTERSECTIONS
1205.05	PAVEMENT MARKINGS - TURN LANES
1205.06	PAVEMENT MARKINGS - LANE DROPS
1205.08	PAVEMENT MARKINGS - SYMBOLS AND WORD MESSAGES
1205.09	PAVEMENT MARKINGS - PAINTED ISLANDS
1205.12	PAVEMENT MARKINGS - BRIDGES
1205.13	PAVEMENT MARKINGS - LANE REDUCTIONS
1250.01	RAISED PAVEMENT MARKERS - INSTALLATION SPACING
1251.01	RAISED PAVEMENT MARKERS - PERMANENT AND TEMPORARY
1253.01	RAISED PAVEMENT MARKERS - SNOWPLOWABLE
1261.01	GUARDRAIL AND BARRIER DELINEATORS - INSTALLATION SPACING
1261.02	GUARDRAIL AND BARRIER DELINEATORS - TYPES AND MOUNTING
1262.01	GUARDRAIL END DELINEATION

PLAN SUBMITTED TO:

DAVID STUTTS, PE

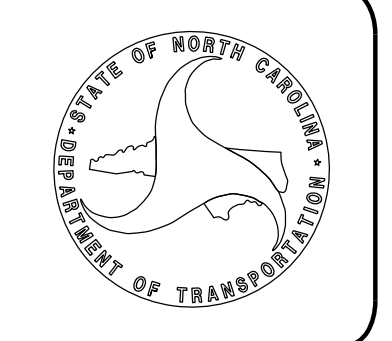

PLAN PREPARED BY:

AECOM NC FIRM LICENSE No: F-0342
5438 Wade Park Boulevard, Suite 200
Raleigh, NC 27604
(919) 461-1100

JEFFREY KOONTZ, PE PROJECT ENGINEER
KALEAB MAREGN, PE DESIGN ENGINEER

2/10/2023
p4\aecom-na-pw\bentley.com\AECOM_DS21_NA_2020\Documents\60581577-NCDDT_SMU_BR-0041\900-CAD_GIS\910-CAD\70-NCDDT_TIP\Signing and Delineation\PMP\BR0041_pmp.psh01.tsh.dgn
Local User

TIP NO.	SHEET NO.
BR - 0041	DocuSigned by PMP - 1A
APPROVED:	<i>Matthew V. Springer</i>
DATE:	8/13/2019
SEAL	



STATE OF NORTH CAROLINA
DEPT. OF TRANSPORTATION
DIVISION OF HIGHWAYS
RALEIGH, N.C.

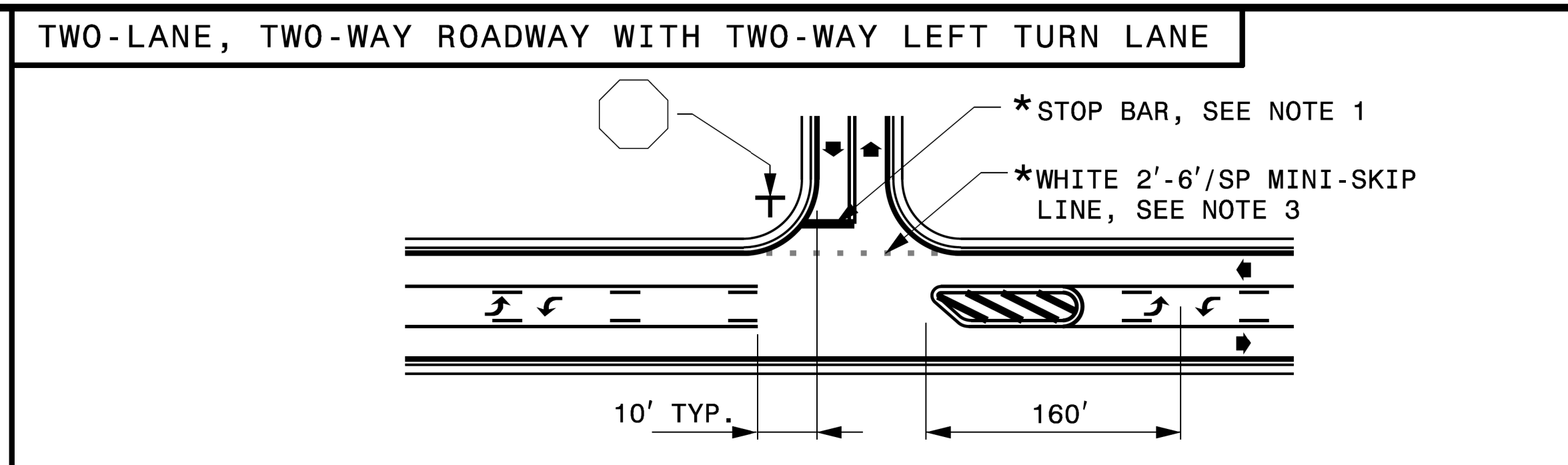
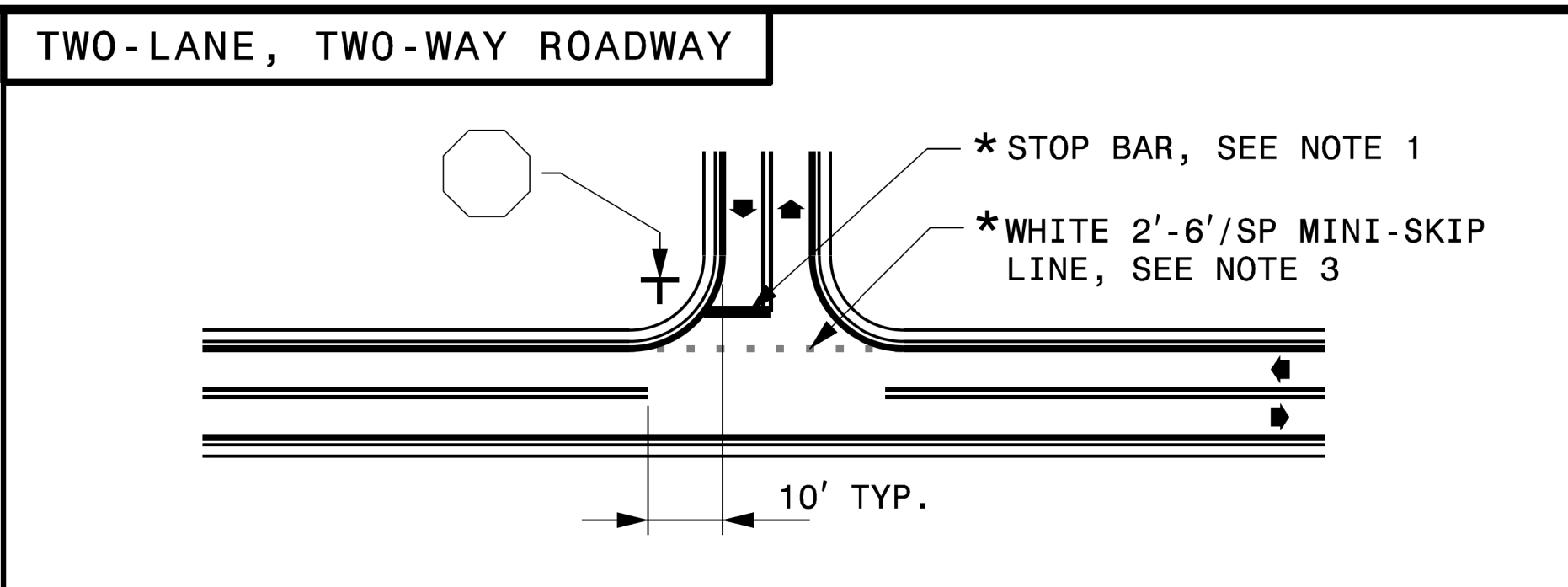

STATE OF NORTH CAROLINA
DEPT. OF TRANSPORTATION
DIVISION OF HIGHWAYS
RALEIGH, N.C.

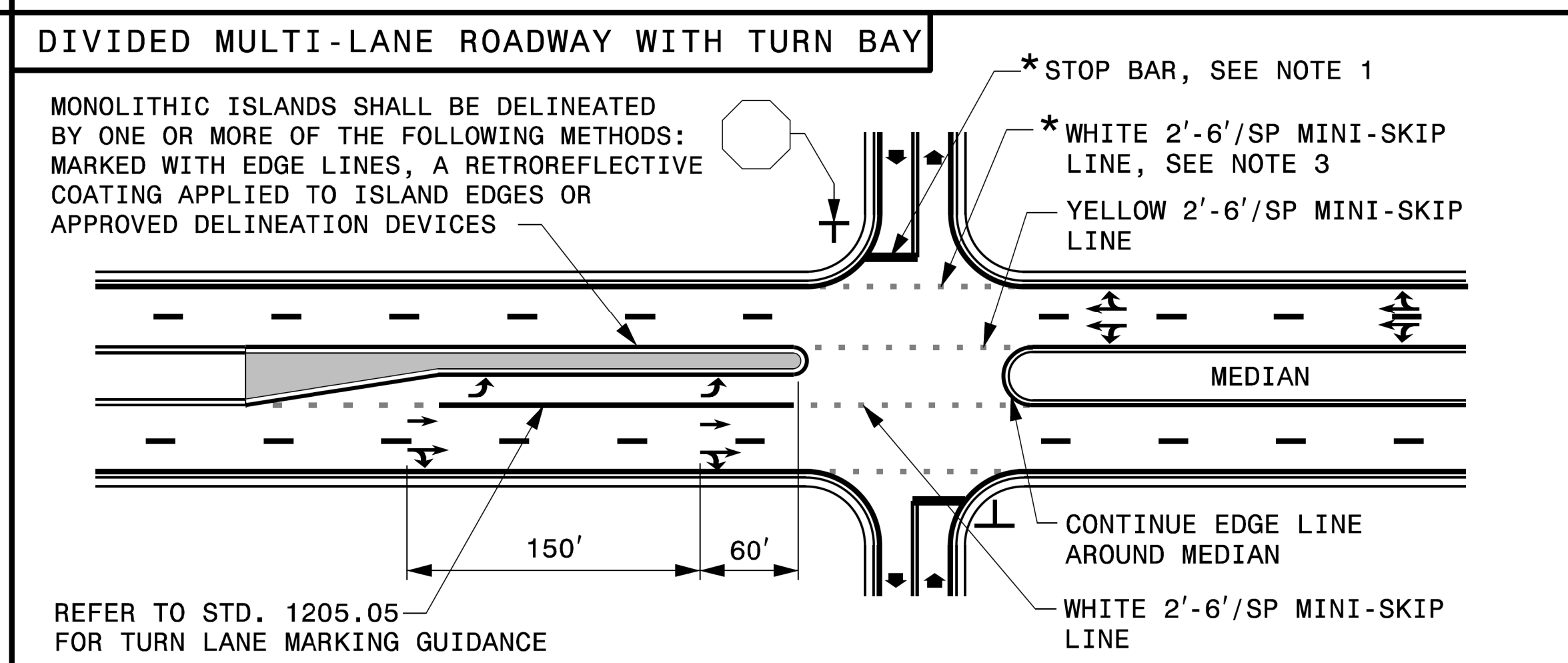
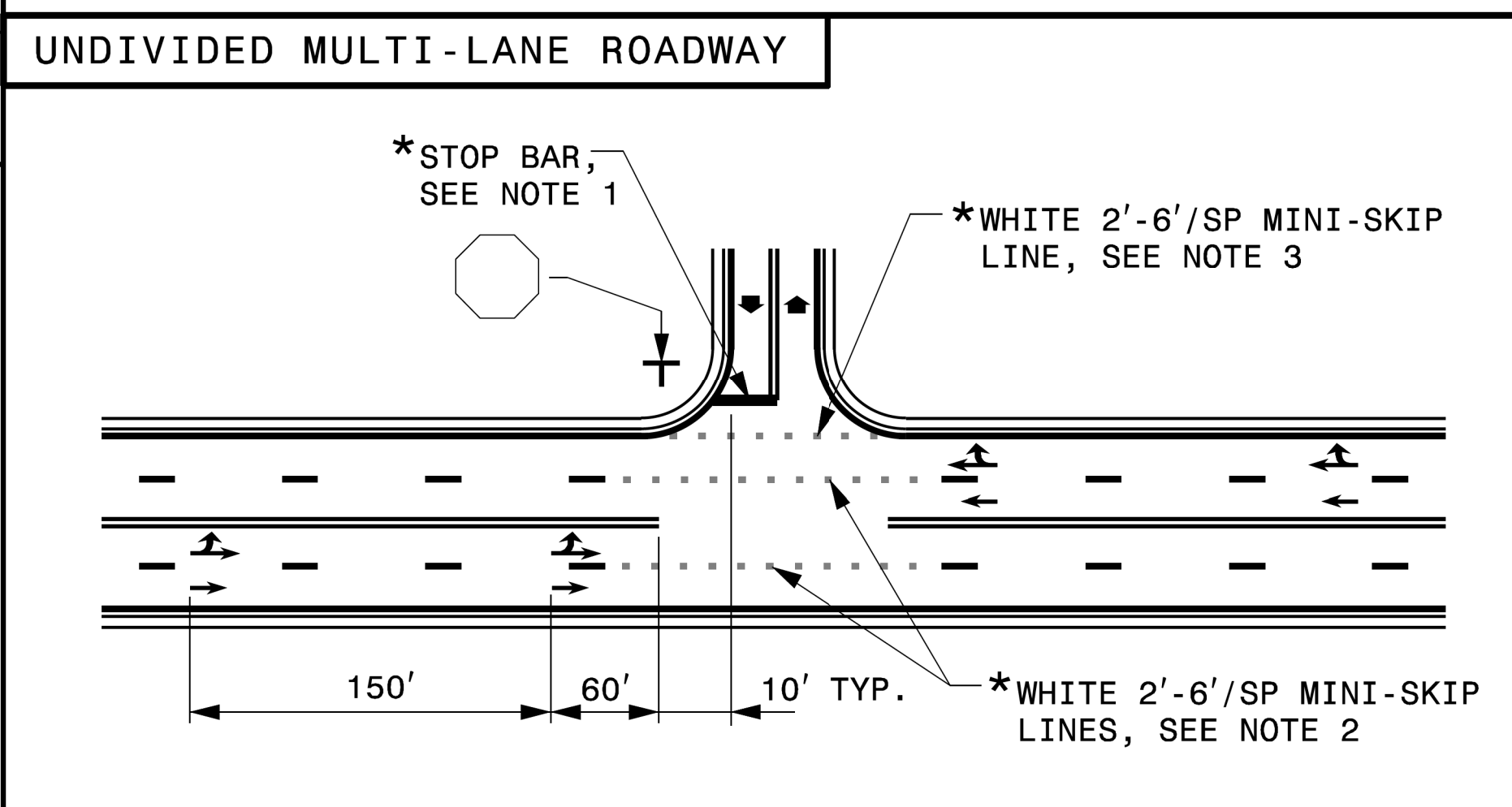

STATE OF NORTH CAROLINA
DEPT. OF TRANSPORTATION
DIVISION OF HIGHWAYS
RALEIGH, N.C.

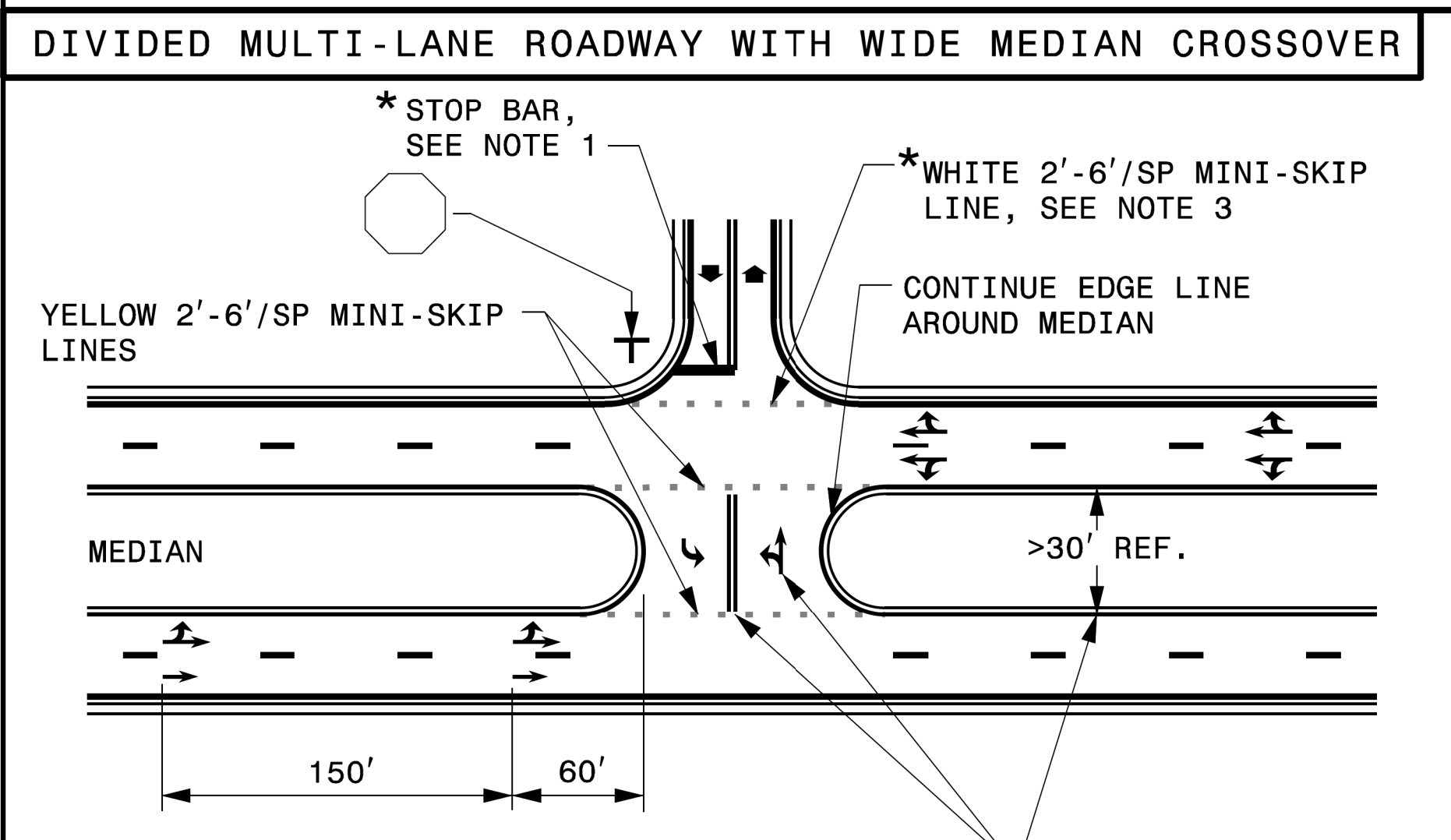

GENERAL NOTES:

- 1- PLACEMENT OF STOP BARS AT NON-SIGNALIZED INTERSECTIONS IS OPTIONAL AND USED WHERE IT IS IMPORTANT TO INDICATE THE POINT WHICH VEHICLES ARE REQUIRED TO STOP. PLACE STOP BARS NO LESS THAN 4 FEET AND NO MORE THAN 30 FEET FROM THE NEAREST EDGE OF THE INTERSECTING ROADWAY. USE 10 FEET AS THE TYPICAL SETBACK DISTANCE OR AS DIRECTED BY THE ENGINEER.
- 2- MINI-SKIP LANE EXTENSIONS SHOULD BE USED AT INTERSECTIONS THAT HAVE REDUCED VISIBILITY CONDITIONS SUCH AS OFFSET, SKEWED, OR CURVED ROADWAYS.
- 3- MINI-SKIP EDGE LINE EXTENSIONS MAY BE PLACED THROUGH INTERSECTIONS AND MAJOR DRIVEWAYS.
- 4- REFER TO ROADWAY STANDARD DRAWINGS 1205.01, 1205.02, 1205.05, 1205.08 AND 1205.09 FOR ADDITIONAL PAVEMENT MARKING GUIDANCE.

LEGEND	
	STOP SIGN
	STATIONARY SIGN
	DIRECTION OF TRAFFIC FLOW
	PAVEMENT MARKING SYMBOLS
*	OPTIONAL

USE DOUBLE YELLOW CENTER LINE AND ARROW SYMBOLS IN MEDIAN CROSSOVER WHEN WIDTH OF MEDIAN EXCEEDS 30 FT, OTHERWISE THEY ARE NOT REQUIRED.

SHEET 2 OF 2
1205D04

SHEET 2 OF 2
1205D04

REVISED PAVEMENT MARKING ROADWAY STANDARD DRAWING

TIP NO. BR-0041	SHEET NO. PMP-2
Approved by: <i>Jeffrey A. Koontz</i> DATE: 2/15/2023	
DOCUMENT NOT CONSIDERED FINAL UNLESS ALL SIGNATURES COMPLETED	

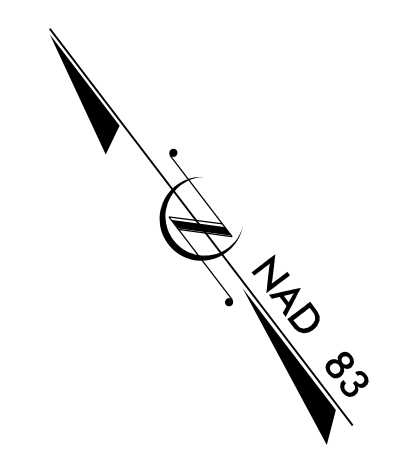

15

20

25

BEGIN TIP PROJECT BR-0041
-L- POT STA. 16+00.00
TIE TO EXISTING MARKINGS

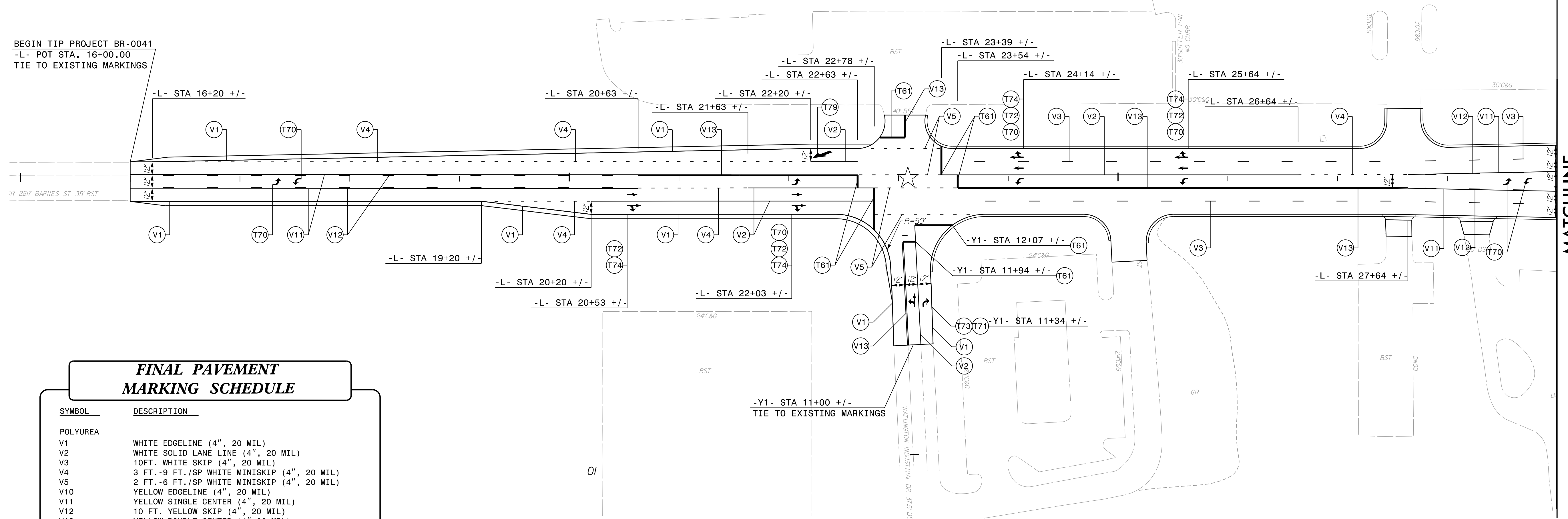

FINAL PAVEMENT MARKING SCHEDULE

SYMBOL	DESCRIPTION
POLYUREA	
V1	WHITE EDGELINE (4", 20 MIL)
V2	WHITE SOLID LANE LINE (4", 20 MIL)
V3	10FT. WHITE SKIP (4", 20 MIL)
V4	3 FT.-9 FT./SP WHITE MINISKIP (4", 20 MIL)
V5	2 FT.-6 FT./SP WHITE MINISKIP (4", 20 MIL)
V10	YELLOW EDGELINE (4", 20 MIL)
V11	YELLOW SINGLE CENTER (4", 20 MIL)
V12	10 FT. YELLOW SKIP (4", 20 MIL)
V13	YELLOW DOUBLE CENTER (4" 20 MIL)
V20	WHITE EDGELINE (6", 20 MIL)
V22	10FT. WHITE SKIP (6", 20 MIL)
V30	YELLOW EDGELINE (6", 20 MIL)
V50	WHITE GORELINE (12", 20 MIL)
THERMOPLASTIC	
T61	WHITE STOPBAR (24", 90 MIL)
T70	LEFT TURN ARROW (90 MIL)
T71	RIGHT TURN ARROW (90 MIL)
T72	STRAIGHT ARROW (90 MIL)
T73	COMBO. LEFT/STRAIGHT ARROW (90 MIL)
T74	COMBO. RIGHT/STRAIGHT ARROW (90 MIL)
T79	MERGE ARROW (90 MIL)
T80	WRONG-WAY RAMP ARROW (90 MIL)
T103	24" YIELD LINE TRIANGLE (90 MIL)

EXISTING SIGNAL

PAVEMENT MARKING DETAIL

MATCHLINE
 -L- STA 29 + 00.00
 SEE SHEET PMP-3

2/9/2023
 p:\aecom-na-pw-bentley.com\AECOM_DS21_NA_2020\Documents\60581577-NC DOT_TIP_Signing and Delineation\PM\BR0041_pmp_psh02.dgn
 localuser

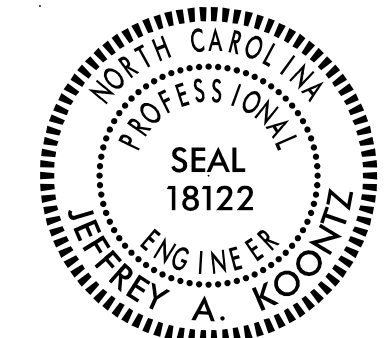
TIP NO. BR-0041	SHEET NO. PMP-3
APPROVED: <i>Jeffrey A. Koontz</i> SHEEP/ECDC22847	
DATE: 2/15/2023	
SEAL 	
DOCUMENT NOT CONSIDERED FINAL UNLESS ALL SIGNATURES COMPLETED	
AECOM <small>NC FIRM LICENSE No. F-0342 5438 Wade Park Boulevard, Suite 200 Raleigh, NC 27607 1997-461-1100</small>	

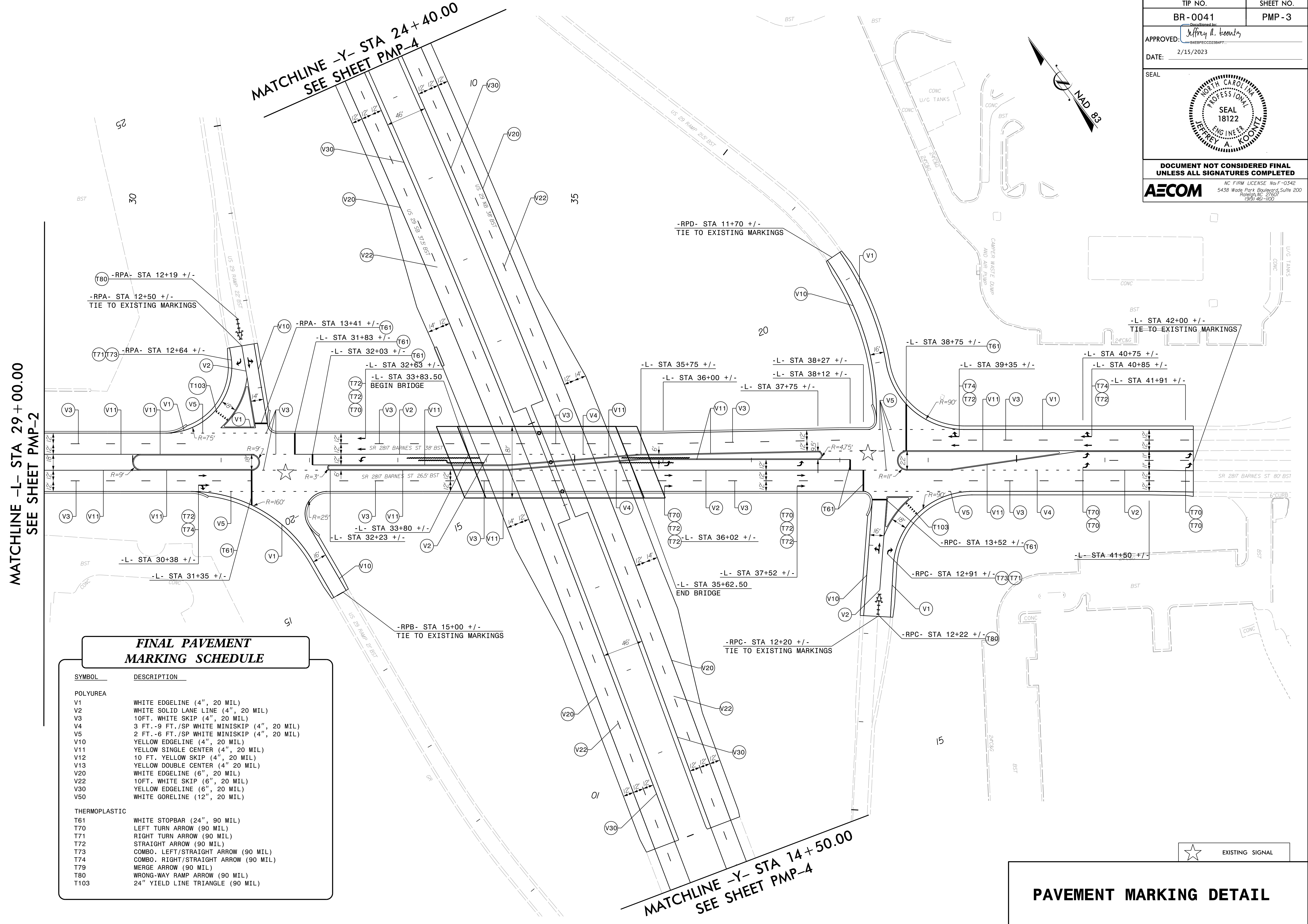

MATCHLINE -L- STA 29+00.00
SEE SHEET PMP-2



MATCHLINE -Y- STA 14+50.00
SEE SHEET PMP-4

FINAL PAVEMENT MARKING SCHEDULE

SYMBOL	DESCRIPTION
POLYUREA	
V1	WHITE EDGELINE (4", 20 MIL)
V2	WHITE SOLID LANE LINE (4", 20 MIL)
V3	10FT. WHITE SKIP (4", 20 MIL)
V4	3 FT.-9 FT./SP WHITE MINISKIP (4", 20 MIL)
V5	2 FT.-6 FT./SP WHITE MINISKIP (4", 20 MIL)
V10	YELLOW EDGELINE (4", 20 MIL)
V11	YELLOW SINGLE CENTER (4", 20 MIL)
V12	10 FT. YELLOW SKIP (4", 20 MIL)
V13	YELLOW DOUBLE CENTER (4" 20 MIL)
V20	WHITE EDGELINE (6", 20 MIL)
V22	10FT. WHITE SKIP (6", 20 MIL)
V30	YELLOW EDGELINE (6", 20 MIL)
V50	WHITE GORELINE (12", 20 MIL)
THERMOPLASTIC	
T61	WHITE STOPBAR (24", 90 MIL)
T70	LEFT TURN ARROW (90 MIL)
T71	RIGHT TURN ARROW (90 MIL)
T72	STRAIGHT ARROW (90 MIL)
T73	COMBO. LEFT/STRAIGHT ARROW (90 MIL)
T74	COMBO. RIGHT/STRAIGHT ARROW (90 MIL)
T79	MERGE ARROW (90 MIL)
T80	WRONG-WAY RAMP ARROW (90 MIL)
T103	24" YIELD LINE TRIANGLE (90 MIL)

PAVEMENT MARKING DETAIL

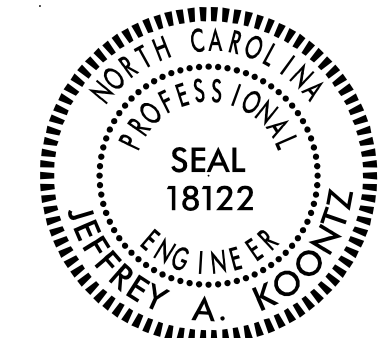
2/9/2023
p:\aecom-na-pw-bentley.com\AECOM_DS21\NA-2020\Documents\60581577-NCDDT SMU BR-0041\900-CAD GIS\910-CAD\70-NCDDT_TIP\Signing and Delineation\PMP\BR0041_pmp_psh03.dgn
localuser

TIP NO. BR-0041	SHEET NO. PMP-4
APPROVED: <i>Jeffrey A. Koontz</i> 848FEEC22384F7	
DATE: 2/15/2023	
SEAL 	
DOCUMENT NOT CONSIDERED FINAL UNLESS ALL SIGNATURES COMPLETED	
 <small>NC FIRM LICENSE No.F-0342 5438 Wade Park Boulevard, Suite 200 Raleigh, NC 27607 1997-461-1100</small>	

MATCHLINE -Y- STA 24 + 40.00
SEE SHEET PMP-3

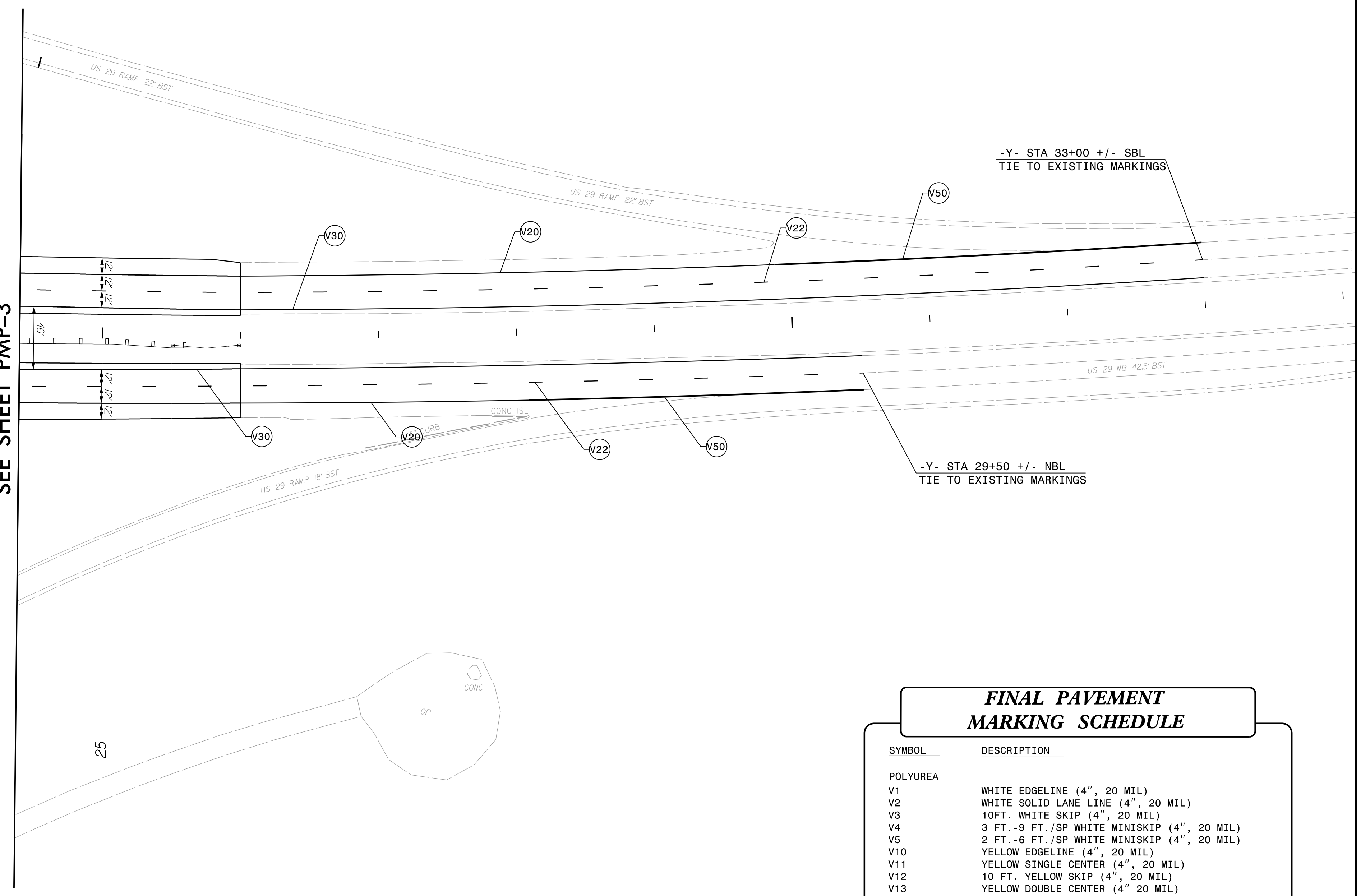

FINAL PAVEMENT MARKING SCHEDULE

SYMBOL	DESCRIPTION
POLYUREA	
V1	WHITE EDGELINE (4", 20 MIL)
V2	WHITE SOLID LANE LINE (4", 20 MIL)
V3	10FT. WHITE SKIP (4", 20 MIL)
V4	3 FT.-9 FT./SP WHITE MINISKIP (4", 20 MIL)
V5	2 FT.-6 FT./SP WHITE MINISKIP (4", 20 MIL)
V10	YELLOW EDGELINE (4", 20 MIL)
V11	YELLOW SINGLE CENTER (4", 20 MIL)
V12	10 FT. YELLOW SKIP (4", 20 MIL)
V13	YELLOW DOUBLE CENTER (4", 20 MIL)
V20	WHITE EDGELINE (6", 20 MIL)
V22	10FT. WHITE SKIP (6", 20 MIL)
V30	YELLOW EDGELINE (6", 20 MIL)
V50	WHITE GORELINE (12", 20 MIL)
THERMOPLASTIC	
T61	WHITE STOPBAR (24", 90 MIL)
T70	LEFT TURN ARROW (90 MIL)
T71	RIGHT TURN ARROW (90 MIL)
T72	STRAIGHT ARROW (90 MIL)
T73	COMBO. LEFT/STRAIGHT ARROW (90 MIL)
T74	COMBO. RIGHT/STRAIGHT ARROW (90 MIL)
T79	MERGE ARROW (90 MIL)
T80	WRONG-WAY RAMP ARROW (90 MIL)
T103	24" YIELD LINE TRIANGLE (90 MIL)

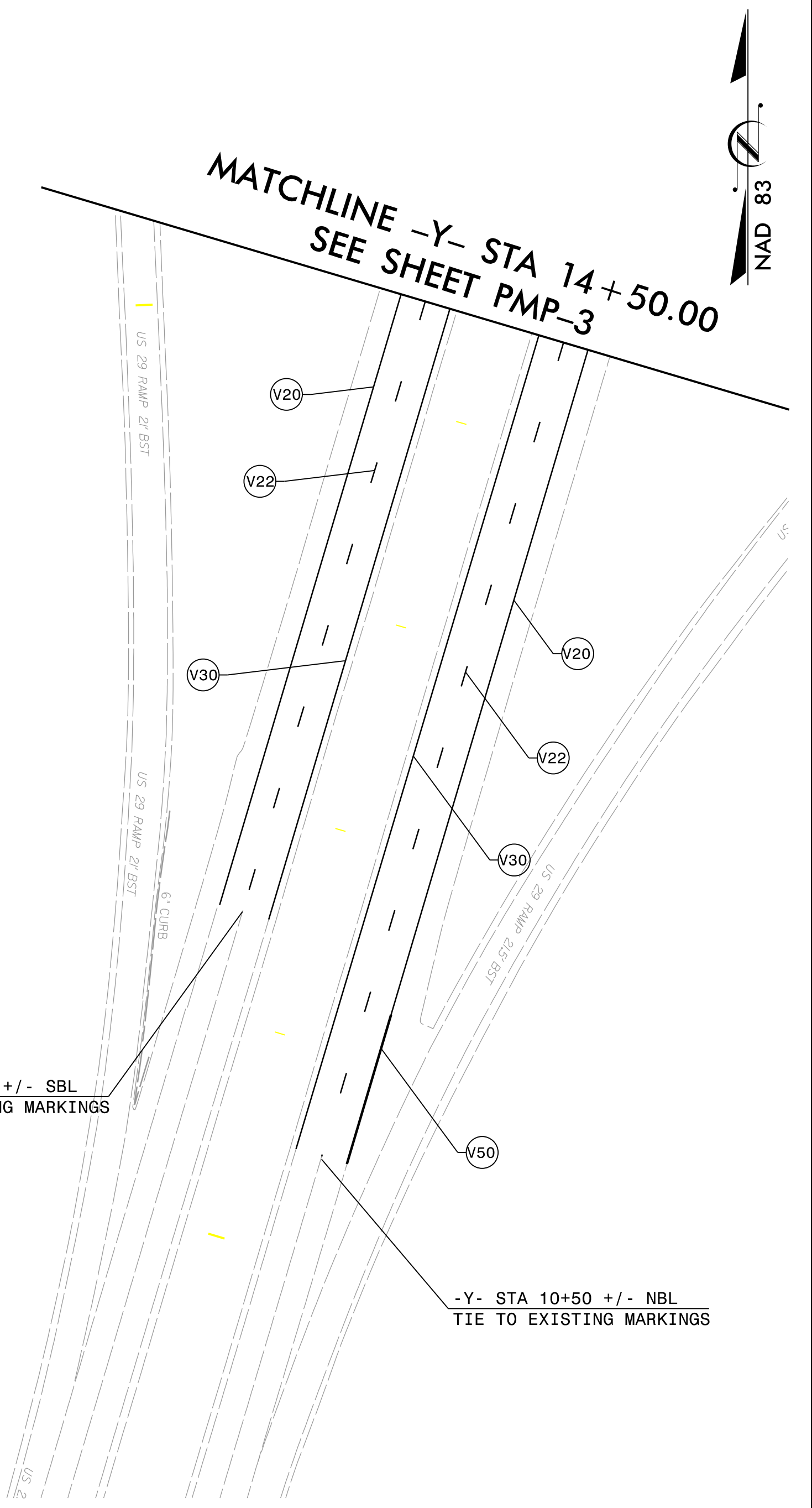

PAVEMENT MARKING DETAIL

2/9/2023
p:\aecom-na-pw-bentley.com\AECOM\DS21\NA_2020\Documents\60581577-NC DOT - TIP - Signing and Delineation\PM\BR0041_pmp_psh04.dgn
localuser