

PLAN

NOTES:

- FOR CONSTRUCTION JOINT DETAIL, SECTIONS A-A AND B-B, SECTION THRU COLUMN, CAP END VIEW, DETAIL "B", AND SHEAR KEY DETAIL, SEE SHEET 3 OF 4.
- STIRRUPS AND "U" BARS IN CAP MAY BE SHIFTED SLIGHTLY TO CLEAR ANCHOR BOLTS.
- ALL STEEL IN THE DRILLED PIERS IS INCLUDED IN THE PAY ITEMS FOR "REINFORCING STEEL" AND "SPIRAL COLUMN REINFORCING STEEL".
- FOR DRILLED PIERS AND PERMANENT STEEL CASING, SEE SECTION 411 OF THE STANDARD SPECIFICATIONS.
- THE CONTRACTOR'S ATTENTION IS CALLED TO THE FACT THAT THE LONGITUDINAL REINFORCEMENT FOR THE DRILLED PIERS IS DETAILED WITH 3 FEET OF EXTRA LENGTH.
- THE LOCATION OF THE CONSTRUCTION JOINT AT BENT 1 IS BASED ON AN APPROXIMATE GROUND LINE ELEVATION. IF THE CONSTRUCTION JOINT IS ABOVE THE ACTUAL GROUND ELEVATION, THE CONTRACTOR SHALL PLACE THE CONSTRUCTION JOINT 1 FOOT BELOW THE GROUND LINE.
- HOOKS ON "V" BARS MAY BE TURNED AS NECESSARY FOR PLACING REINFORCING STEEL.
- SEE PILE AND DRILLED PIER FOUNDATION TABLES FOR DRILLED PIER FOUNDATION DATA.
- MECHANICAL COUPLERS SHALL BE USED TO JOIN THE #9 BARS IN STAGE I WITH THE #9 "B" BARS IN STAGE II.
- FOR MECHANICAL COUPLERS, SEE MECHANICAL BUTT SPLICES FOR REINFORCING STEEL IN STANDARD SPECIFICATIONS.
- THE CONTRACTOR'S ATTENTION IS CALLED TO THE FACT THAT THE LENGTHS OF THE #9 "B" BARS AT THE STAGED CONSTRUCTION JOINT MAY NEED TO BE ADJUSTED DUE TO THE TYPE OF MECHANICAL BUTT SPLICE CHOSEN BY THE CONTRACTOR. NO ADDITIONAL PAYMENT WILL BE MADE FOR ANY ADJUSTMENTS.

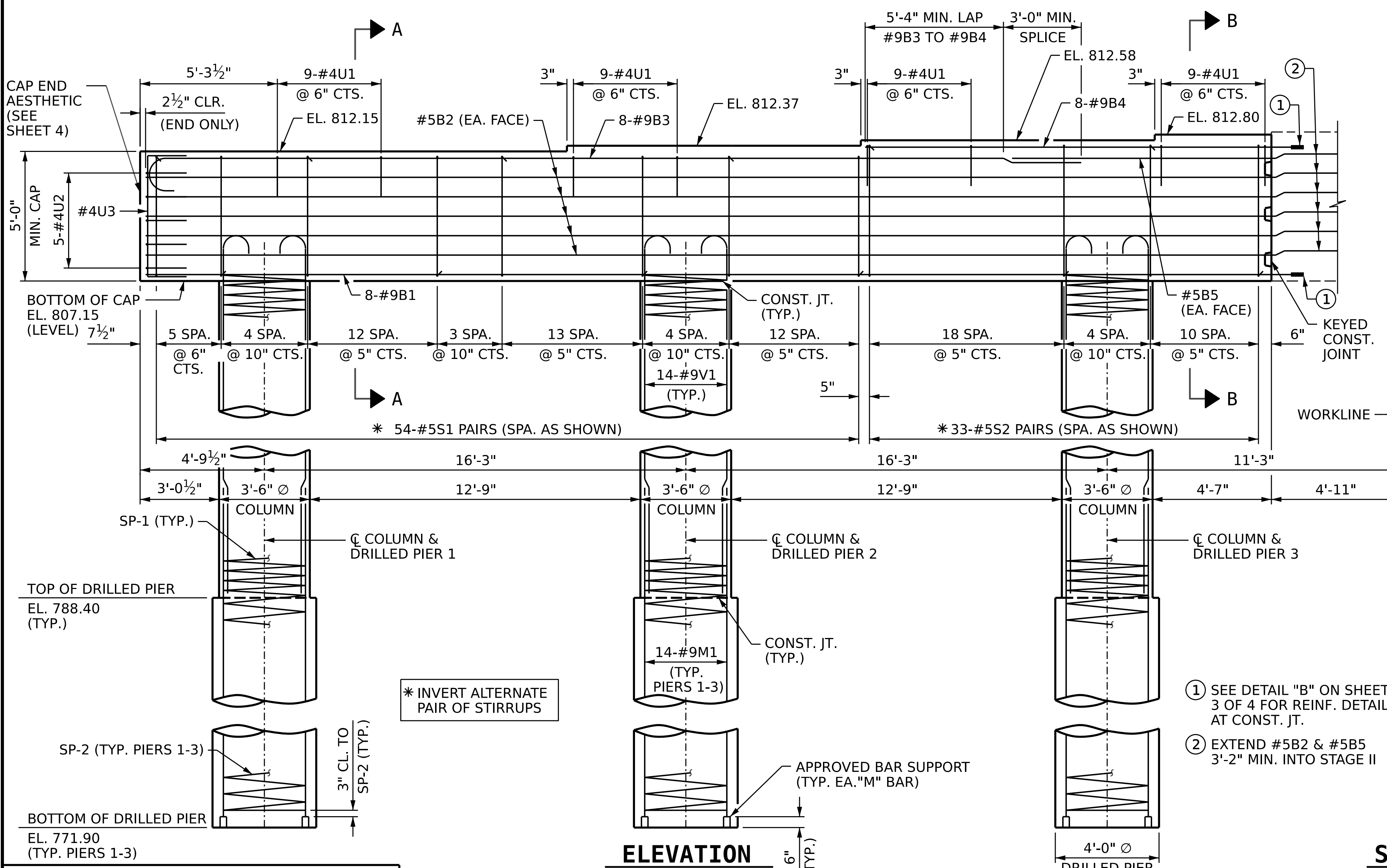

ELEVATION

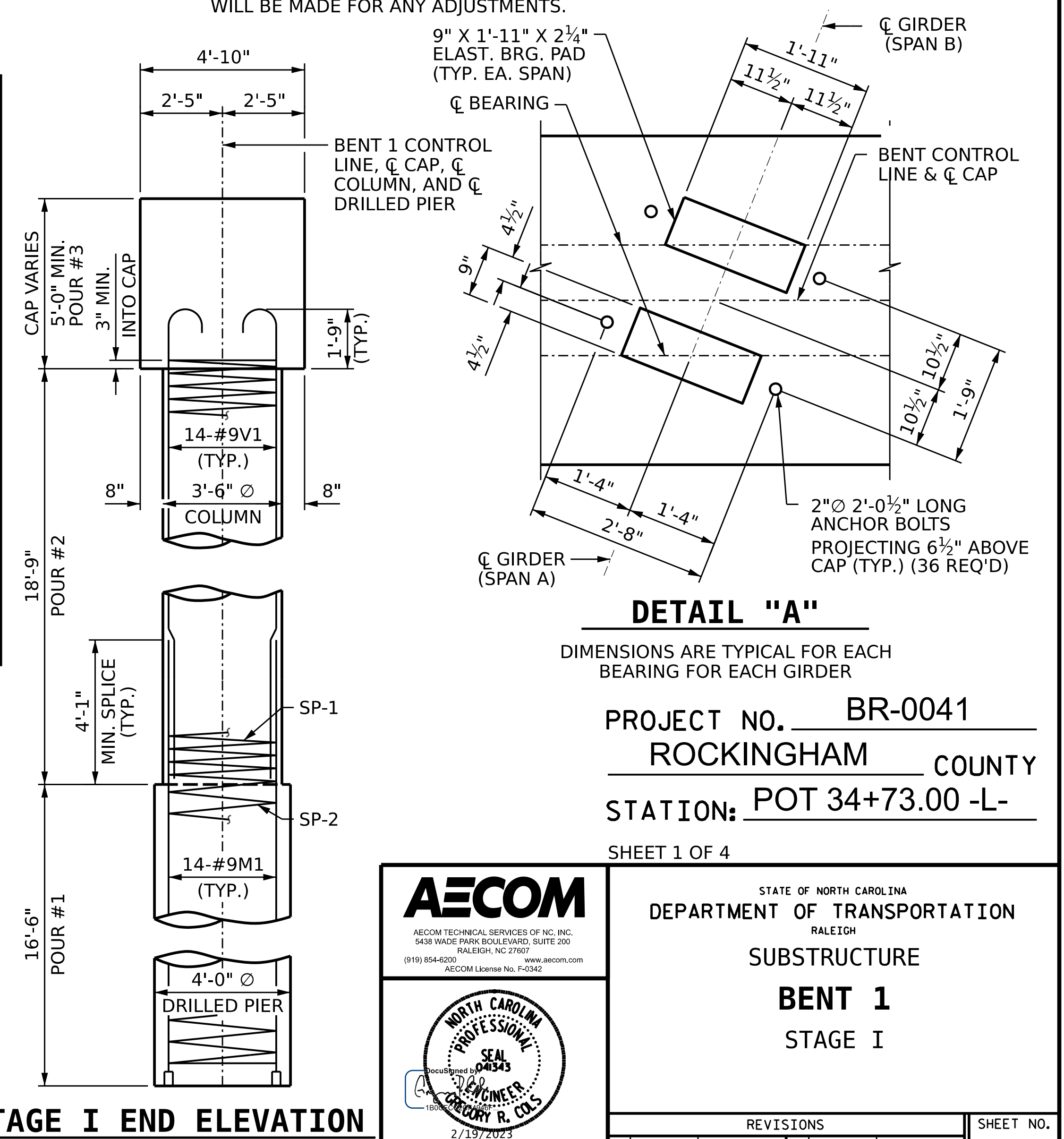

STAGE I END ELEVATION

DETAIL "A"

DIMENSIONS ARE TYPICAL FOR EACH BEARING FOR EACH GIRDER

PROJECT NO. **BR-0041**
ROCKINGHAM COUNTY
 STATION: **POT 34+73.00 -L-**
 SHEET 1 OF 4

STATE OF NORTH CAROLINA DEPARTMENT OF TRANSPORTATION RALEIGH					
SUBSTRUCTURE					
BENT 1					
STAGE I					
REVISIONS					
NO.	BY:	DATE:	NO.	BY:	DATE:
1			3		
2			4		
					SHEET NO. S-36 TOTAL SHEETS 48

DRAWN BY :	D.R. DRUM	DATE :	09/2022
CHECKED BY :	S. NATARAJAN	DATE :	10/2022
DESIGN ENGINEER OF RECORD:	G. COLS	DATE :	12/2022

DOCUMENT NOT CONSIDERED FINAL UNLESS ALL SIGNATURES COMPLETED