

### 18 CHANNEL CONFLICT MONITOR PROGRAMMING DETAIL

(remove jumpers and set switches as shown)

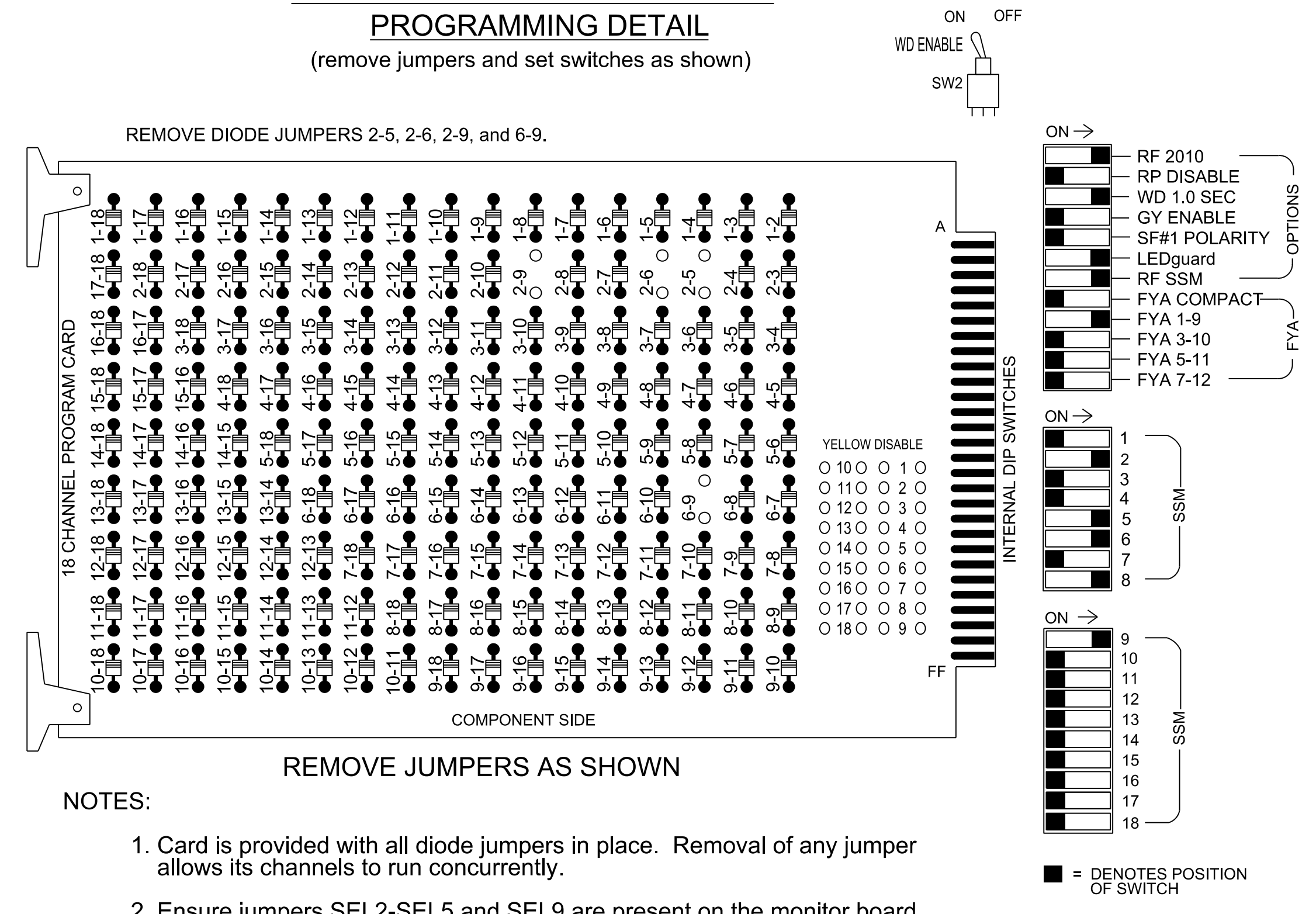

- NOTES:**
- Card is provided with all diode jumpers in place. Removal of any jumper allows its channels to run concurrently.
  - Ensure jumpers SEL2-SEL5 and SEL9 are present on the monitor board.
  - Ensure that the Red Enable is active at all times during normal operation.
  - Connect serial cable from conflict monitor to comm. port 1 of 2070 controller. Ensure conflict monitor communicates with 2070.

### NOTES

- To prevent "flash-conflict" problems, insert red flash program blocks for all unused vehicle load switches in the output file. The installer shall verify that signal heads flash in accordance with the signal plan.
- Program controller to start up in phase 2 Green No Walk and 6 Green No Walk.
- If this signal will be managed by an ATMS software, enable controller and detector logging for all detectors used at this location.
- The cabinet and controller are part of NC 87/ SR 2817 (Barnes Street) Closed Loop System. Signal System #: D07-10 Reidsville.

### EQUIPMENT INFORMATION

Controller.....2070LX  
 Cabinet.....332 w/ Aux  
 Software.....Q-Free MAXTIME  
 Cabinet Mount.....BASE  
 Output File Positions.....18 With Aux. Output File  
 Load Switches Used.....S2, S7, S8, S11, AUX S1  
 Phases Used.....2, 5, 6, 8  
 Overlap "1".....\*  
 Overlap "2".....NOT USED  
 Overlap "3".....NOT USED  
 Overlap "4".....NOT USED

\*See overlap programming detail on this sheet.

### SIGNAL HEAD HOOK-UP CHART

LOAD SWITCH NO.	S1	S2	S3	S4	S5	S6	S7	S8	S9	S10	S11	S12	AUX S1	AUX S2	AUX S3	AUX S4	AUX S5	AUX S6
CMU CHANNEL NO.	1	2	13	3	4	14	5	6	15	7	8	16	9	10	17	11	12	18
PHASE	1	2	2 PED	3	4	4 PED	5	6	6 PED	7	8	8 PED	OL1	OL2	SPARE	OL3	OL4	SPARE
SIGNAL HEAD NO.	NU	21	22	NU	NU	NU	21	61	62	NU	NU	81,82	63	NU	NU	NU	NU	NU
RED		128	128				*	134	134			107	A121					
YELLOW		129	129					135	135			108						
GREEN		130							136			109						
RED ARROW																		
YELLOW ARROW							132						A122					
FLASHING YELLOW ARROW													A123					
GREEN ARROW		130					133	136										

NU = Not Used  
 \* Denotes install load resistor. See load resistor installation detail this sheet.  
 \* See pictorial of head wiring in detail this sheet.

### INPUT FILE POSITION LAYOUT

(front view)

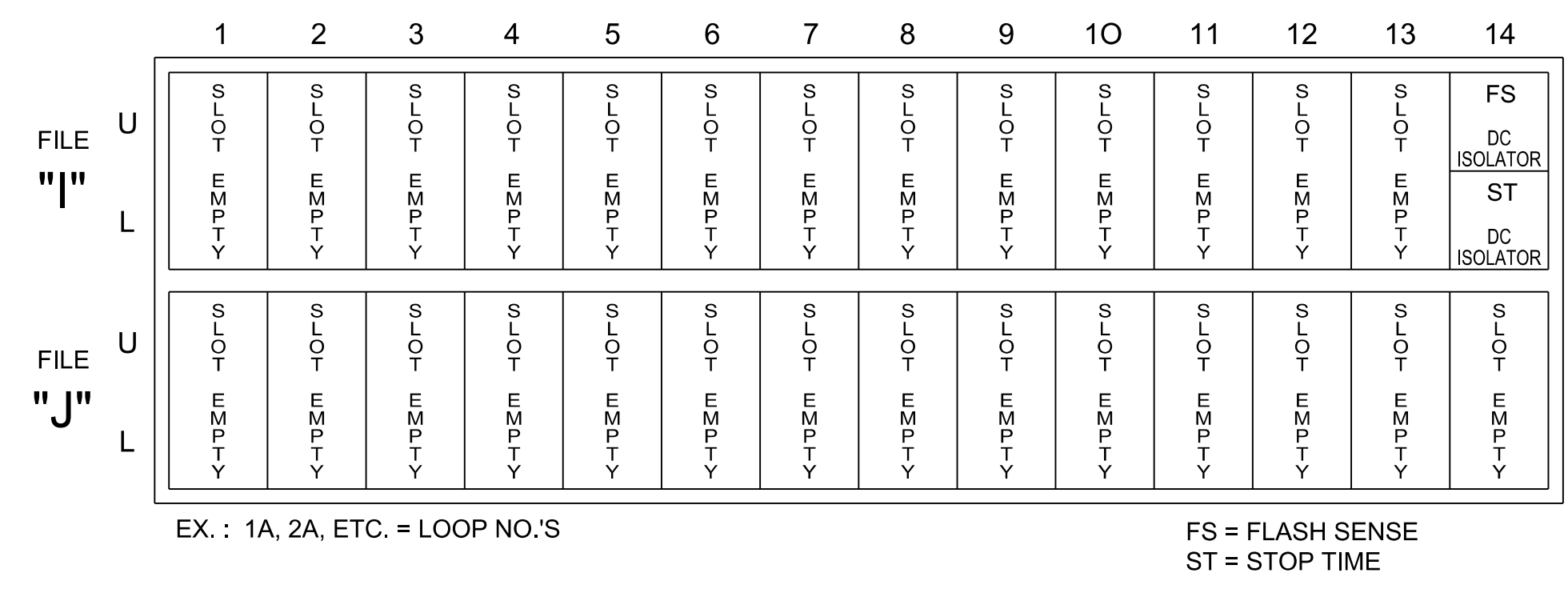

### SPECIAL DETECTOR NOTE

Install a video detection system for vehicle detection. Perform installation according to manufacturer's directions and NCDOT engineer-approved mounting locations to accomplish the detection schemes shown on the Signal Design Plans.

### FYA SIGNAL WIRING DETAIL

(wire signal head as shown)

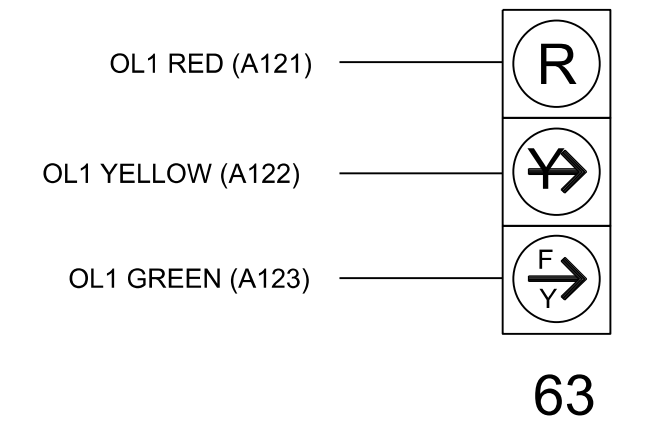

### LOAD RESISTOR INSTALLATION DETAIL

(install resistor as shown)

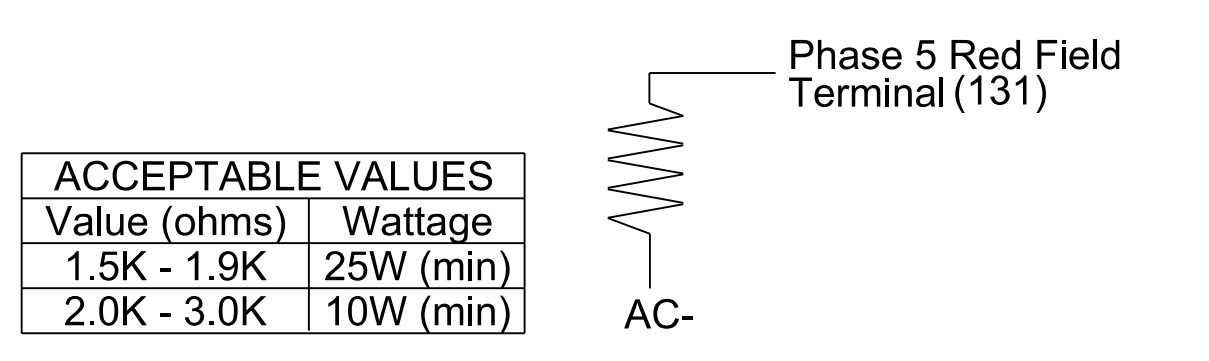

### OVERLAP PROGRAMMING

Front Panel  
 Main Menu > Controller > Overlap > Overlap Parameters/Overlap Timings

Web Interface  
 Home > Controller > Overlap Configuration > Overlaps

Overlap Plan 1

Overlap	1	2	3	4
Type	FYA 4 - Section	-	-	-
Included Phases	6	-	-	-
Modifier Phases	-	-	-	-
Trail Green	0	-	-	-
Trail Yellow	0.0	-	-	-
Trail Red	0.0	-	-	-

THIS ELECTRICAL DETAIL IS FOR THE SIGNAL DESIGN: 07-1675T2  
 DESIGNED: Jan 2023  
 SEALED: 3/10/2023  
 REVISED:

Temporary Design 2 (TMP Phase II)  
 Electrical Detail

Prepared for the Offices of:  
  
 750 N. Greenfield Pkwy, Garner, NC 27529

Electrical and Programming Details For:  
**SR 2817 (Barnes Street) at US 29 NB Ramps**

Division 7 Rockingham County Reidsville

PLAN DATE: January 2023 REVIEWED BY: H M Surti

PREPARED BY: A Raviapati REVIEWED BY:

REVISIONS	INIT.	DATE

DocuSigned by:  
  
 Hemang M. Surti 3/10/2023

DOCUMENT NOT CONSIDERED FINAL UNLESS ALL SIGNATURES COMPLETED

SEAL  
  
 Hemang M. Surti, License No. 034481, State of North Carolina

SIG. INVENTORY NO. 07-1675T2



3/10/2023 10:23:51 AM C:\Users\paw.bentl\OneDrive\Documents\60581577-NCDDT-SMU\BR-0041\300-CAD\6154910-CAD\70-NCDDT-TIP\K51gnal\smle\gph\elc\trf\col\Detail\1\_2022\MAXTIME\_3-10-23\4071675T2-smle\_2022XXXX.dgn  
 mitchell.covenough