

**PROJECT: BP7.R006**

PLOT DRIVER: NCDOT\_pdf\_color\_eng\_50.pht  
 USER: CHARNDEN  
 FILE: p:\p\h\dr\users\01\HARNDEN\US\_Eost\_01\Documents\5705\1012\116\6\_0\_CAD\_BIM\6.2\_WIP\Tr-offic\Signing\CADD\Signing Layout Plans\400225\_SIGN\_S01.dgn

**STATE OF NORTH CAROLINA  
 DEPARTMENT OF TRANSPORTATION**

**SIGNING PLAN  
 GUILFORD COUNTY**

**LOCATION: BRIDGE NO. 225 OVER US 29/70 ON  
 SR 1115 (REHOBETH CHURCH ROAD)**

TIP NO. BP7.R006	SHEET NO. SIGN-1
APPROVED: <i>Michael T. Rzepka</i>	
DATE: 1/20/2023	
	
<b>DOCUMENT NOT CONSIDERED FINAL          UNLESS ALL SIGNATURES COMPLETED</b>	

**SUMMARY OF QUANTITIES**

ITEM NO.		ITEM DESCRIPTION	QUANTITY	UNIT
DESC. NO.	SECT. NO.			
4072000000	903	SUPPORTS, 3 LB STEEL U-CHANNEL	600	L.F.
4096000000	904	SIGN ERECTION, TYPE D	5	EA.
4102000000	904	SIGN ERECTION, TYPE E	14	EA.
4108000000	904	SIGN ERECTION, TYPE F	8	EA.
4116100000	904	SIGN ERECTION, RELOCATE SIGN TYPE D	1	EA.
4155000000	907	DISPOSAL OF SIGN SYSTEM, U-CHANNEL	24	EA.
4192000000	907	DISPOSAL OF SUPPORT, U-CHANNEL	2	EA.

**INDEX**

SHEET NO.	DESCRIPTION
SIGN-1	TITLE SHEET
SIGN-1A	REVISED RSD 904.50, SHEET 1 OF 2
SIGN-2	TYPE "E" AND "F" SIGNS SHEET
SIGN-3 AND SIGN-3A	TYPE "D" SIGN DESIGNS
SIGN-4 AND SIGN-5	SIGN DETAIL SHEETS

**ROADWAY STANDARD DRAWING**

THE FOLLOWING ROADWAY STANDARDS AS APPEAR IN "ROADWAY STANDARD DRAWINGS" -  
 N.C. DEPARTMENT OF TRANSPORTATION - RALEIGH, N.C., DATED JANUARY 2018  
 ARE APPLICABLE TO THIS PROJECT AND BY REFERENCE HEREBY ARE CONSIDERED  
 A PART OF THESE PLANS:

STD. NO.	TITLE
904.10	ORIENTATION OF GROUND MOUNTED SIGNS
904.50, SHEET 2 OF 2	MOUNTING OF TYPE 'D', 'E' AND 'F' SIGNS ON 'U' CHANNEL POSTS
1264.01	OBJECT MARKERS TYPES
1264.02	OBJECT MARKERS INSTALLATION

**GENERAL NOTES**

- SIGNS FURNISHED BY STATE.
- CONFIRM IN WRITING AT LEAST 4 MONTHS IN ADVANCE, THE ACTUAL DATE THE DEPARTMENT FURNISHED SIGNS WILL BE REQUIRED.
- ALL TYPE 'D' SIGNS SHALL BE MOUNTED ON TWO U-CHANNEL POSTS UNLESS OTHERWISE INDICATED ON THE PLANS.
- IF REMOVAL OR RELOCATION OF SIGNS ON PRIVATE STREET (NON-STATE MAINTAINED) IS REQUIRED DUE TO CONSTRUCTION, THE CONTRACTOR SHALL INFORM THE ENGINEER. THE WORK WILL BE COMPLETED BY OTHERS.
- WHEN NOT STATIONED OR DIMENSIONED ON PLANS, ALL 'E' AND 'F' SIGNS SHALL BE FIELD LOCATED BY THE ENGINEER.
- ALL EXISTING SIGNS ON "U" CHANNEL POST WITHIN THE PROJECT LIMITS SHALL BE REMOVED AND DISPOSED OF UNLESS OTHERWISE NOTED ON PLANS.
- THE BACKGROUND FOR TYPE E & F SIGNS SHALL BE TYPE C REFLECTIVE SHEETING.
- SEE ROADWAY PLANS FOR GUARD/GUIDE RAIL DETAILS.

**PLAN REVIEWED BY: N.C.D.O.T. SIGNING AND DELINEATION UNIT**

KELVIN JORDAN \_\_\_\_\_ SIGNING & DELINEATION STANDARDS ENGINEER  
 \_\_\_\_\_ SIGNING & DELINEATION PROJECT DESIGN ENGINEER

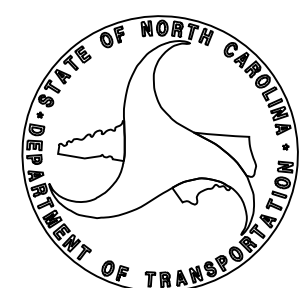

**PLAN PREPARED BY: HDR ENGINEERING, INC. OF THE CAROLINAS**

MIKE RZEPKA, P.E. \_\_\_\_\_ SIGNING & DELINEATION PROJECT DESIGN ENGINEER  
 CHRIS HARNDEN \_\_\_\_\_ SIGNING & DELINEATION PROJECT DESIGN TECHNICIAN



TIP NO.	SHEET NO.
XXXXXX	XXXXXX
APPROVED: <i>Matthew V. Springer</i>	DESIGNED BY: SIGN-1A
DATE: 6/23/2021	
SEAL	
	

STATE OF NORTH CAROLINA  
DEPT. OF TRANSPORTATION  
DIVISION OF HIGHWAYS  
RALEIGH, N.C.

6-21

ENGLISH DETAIL DRAWING FOR  
MOUNTING OF  
TYPE 'D', 'E' AND 'F' SIGNS  
ON 'U' CHANNEL POSTS

SHEET 1 OF 2  
904D50

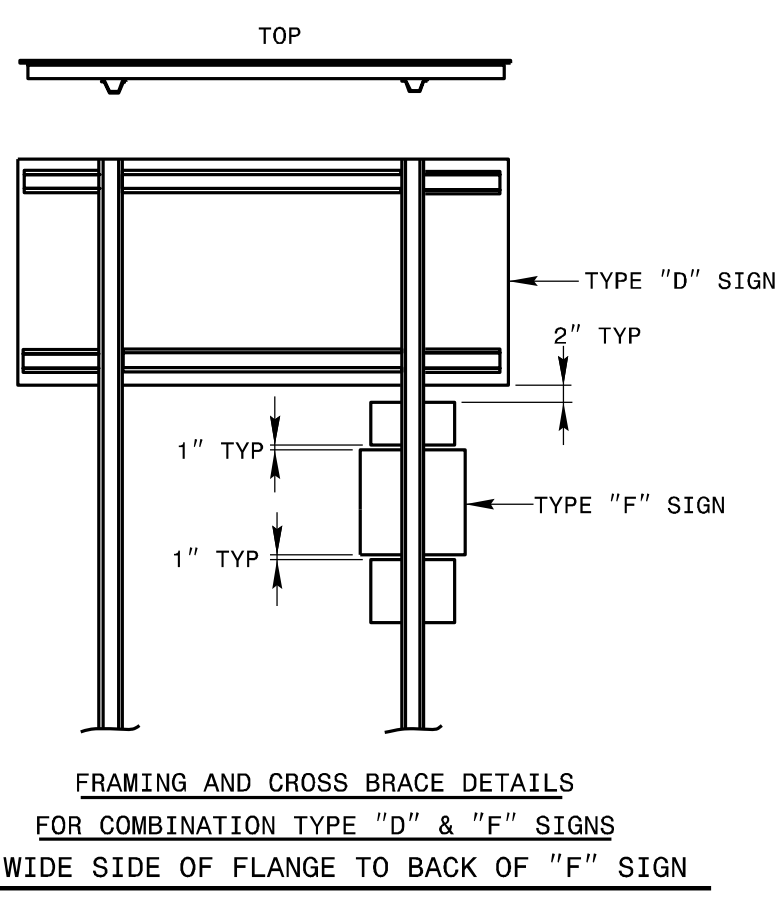
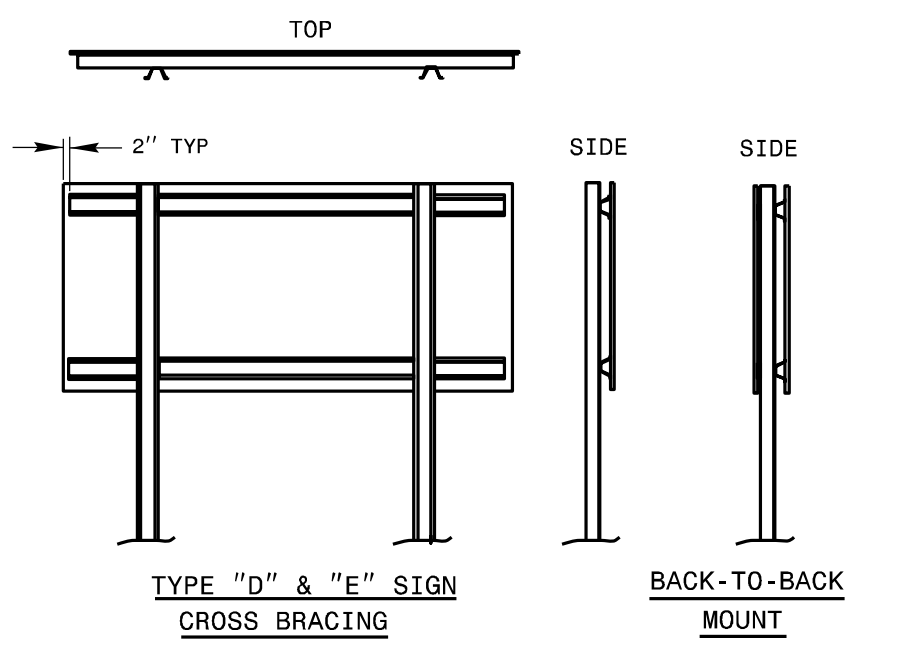
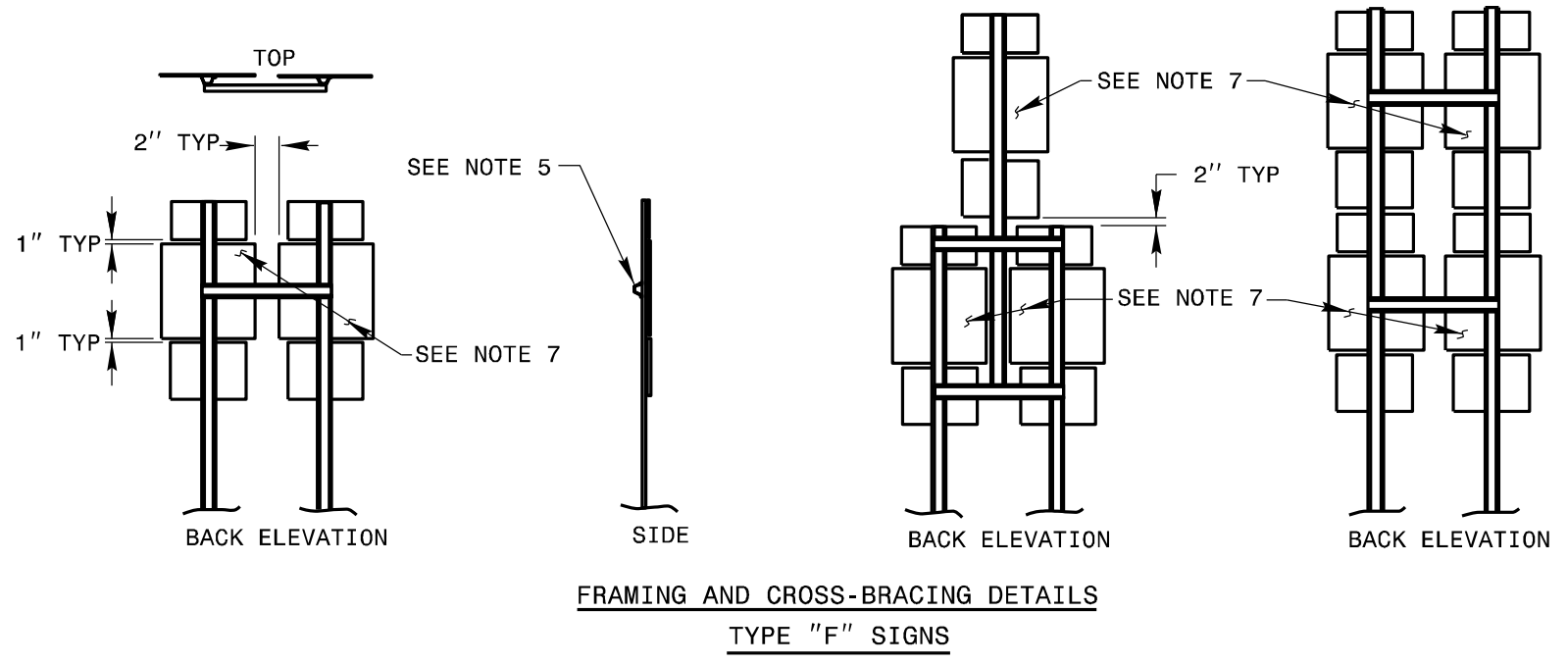
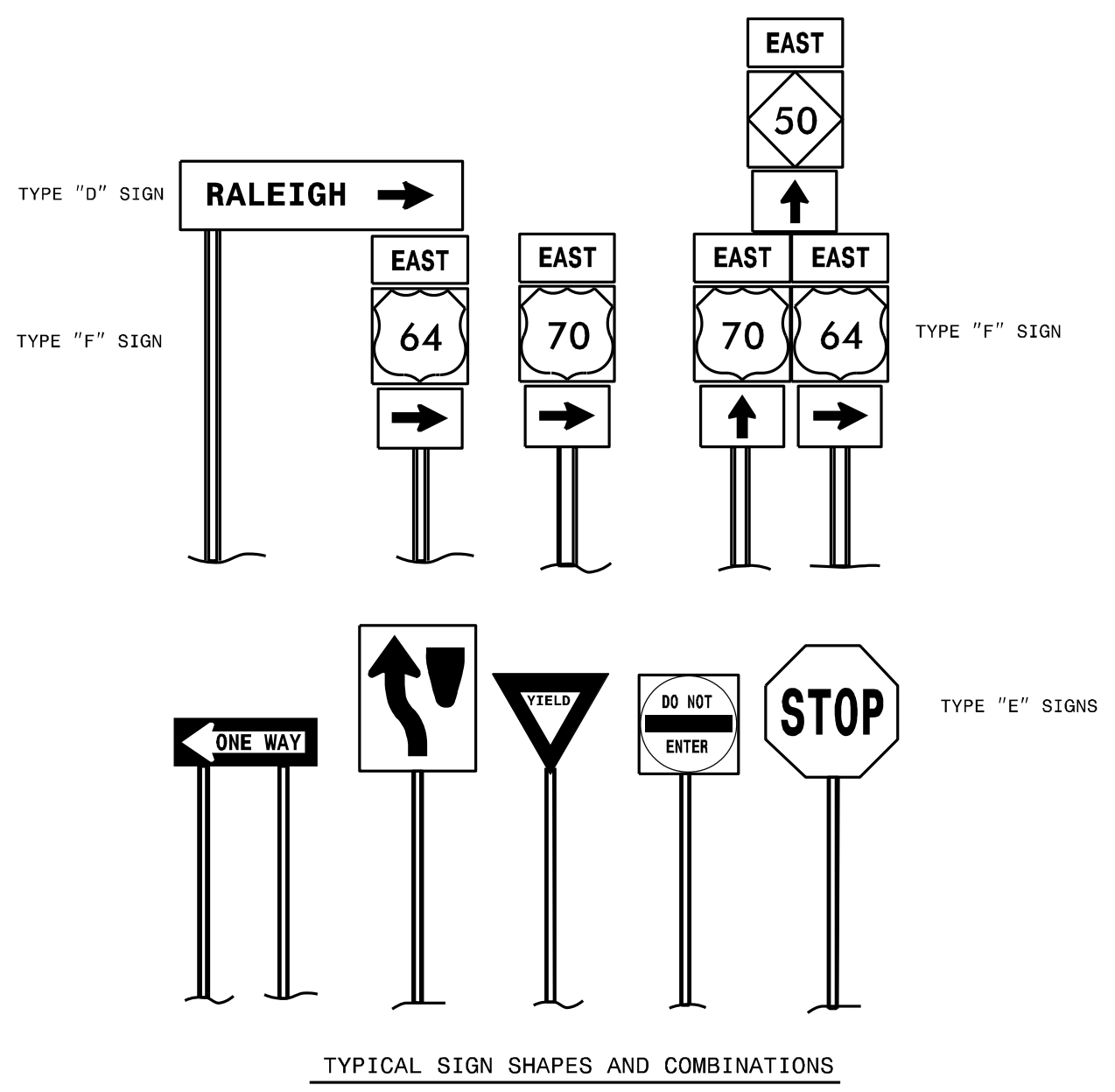
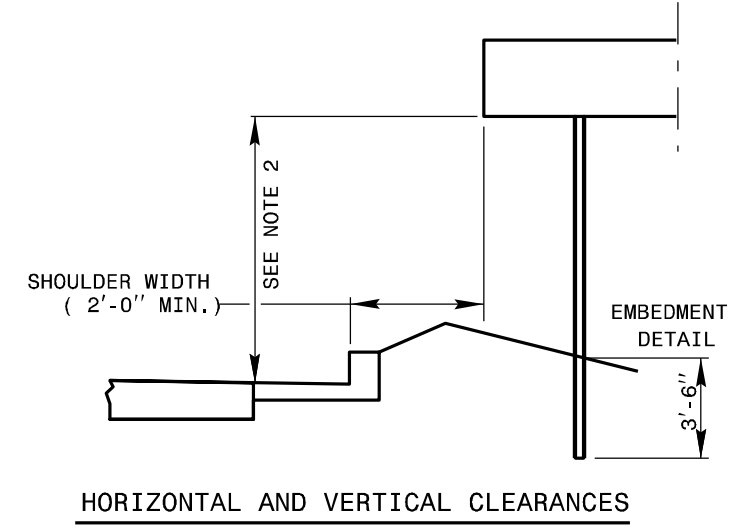
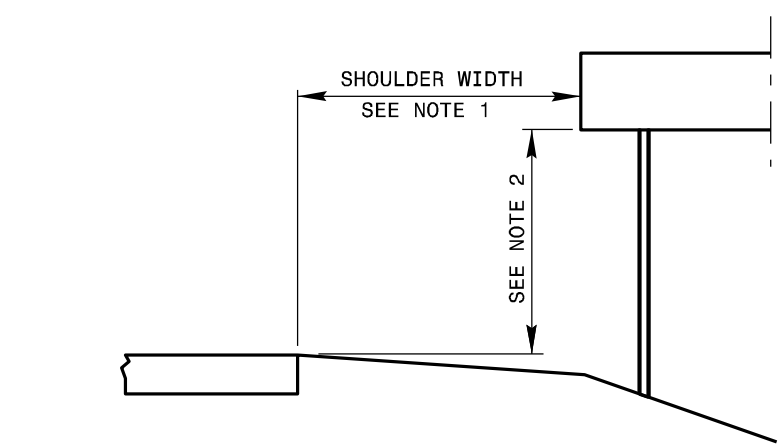

NOTES:

- ERECT TYPE "D", "E", AND "F" SIGNS ON FREEWAYS WITH THE NEAR EDGE OF THE SIGN 20 FT. FROM THE TRAVEL LANE. ERECT ALL OTHER "D", "E", AND "F" SIGNS WITH THE NEAR EDGE OF THE SIGN AT THE EDGE OF THE SHOULDER BREAK (6 FT. MINIMUM CLEARANCE, 12 FT. DESIRABLE, FROM THE EDGE OF TRAVEL LANE), OR AS DIMENSIONED ON PLAN SHEETS.
- ERECT TYPE "D", "E", AND "F" SIGNS WITH THE BOTTOM OF SIGN ASSEMBLY AT LEAST 7 FT. ABOVE THE EDGE OF THE TRAVEL LANE ON ROADS WITH 2 OR MORE LANES IN THE SAME DIRECTION AND AT LEAST 5 FT. ON OTHER ROUTES. THE VERTICAL CLEARANCE IS 7 FT. WHERE REQUIRED FOR PEDESTRIAN TRAFFIC AND/OR PARKED VEHICLES.
- THE VERTICAL DIMENSION BETWEEN MOUNTING HOLE CENTERS ON ALL TYPES "D", "E", AND "F" SIGNS IS 30" MAXIMUM. THE VERTICAL AND HORIZONTAL DIMENSIONS BETWEEN MOUNTING HOLES IS TO THE WHOLE INCH. EACH SIGN PANEL HAS A MINIMUM OF 2 BOLTS PER SUPPORT.
- ATTACH SIGN W/ 3/8" HEX HEAD BOLT, NYLON WASHER, SHIM, FLAT WASHER, LOCK WASHER, HEX NUT. NO BUCKLING OF THE SIGN WILL BE PERMITTED. SEE ASSEMBLY DETAIL SHEET# 2 OF 904.50.
- FURNISH AND INSTALL CROSS-BRACING AS SHOWN IN DETAIL. PAINT ENDS OF CROSS BRACES W/ APPROVED. ZINC PAINT
- INSTALL POST AND CROSS-BRACING WITH THE WIDE SIDE OF THE FLANGE TOWARD THE BACK OF SIGN(S) FOR COMBINATION TYPE "D" AND "F" SIGNS.
- THE SHIELD HEIGHTS IN THESE ASSEMBLIES CAN NOT BE LARGER THAN 24".
- IF SIGN ASSEMBLIES REQUIRE MORE THAN TWO U-CHANNEL SUPPORTS, THE SUPPORTS SHALL BE PLACED A MINIMUM OF 4 FT. BETWEEN POSTS. NO MORE THAN TWO POSTS SHALL FALL WITHIN 7 FT. PATH, OR THE SIGN ASSEMBLY MUST BE PLACED BEHIND BARRIER PROTECTION.

STATE OF NORTH CAROLINA  
DEPT. OF TRANSPORTATION  
DIVISION OF HIGHWAYS  
RALEIGH, N.C.

6-21

ENGLISH DETAIL DRAWING FOR  
MOUNTING OF  
TYPE 'D', 'E' AND 'F' SIGNS  
ON 'U' CHANNEL POSTS

SHEET 1 OF 2  
904D50

REVISED SIGNING  
ROADWAY STANDARD DRAWING

6/18/2021  
S:\S&DU\Standards Group\Standards and Drawings\Drawings\2018 Standard Dwg\Division 9 Final\904.50\_sgn\_sht01\_uchannel.post\_6-21.dgn  
User:rstokes

APPROVED: Michael T. Rzepka  
DATE: 1/20/2023

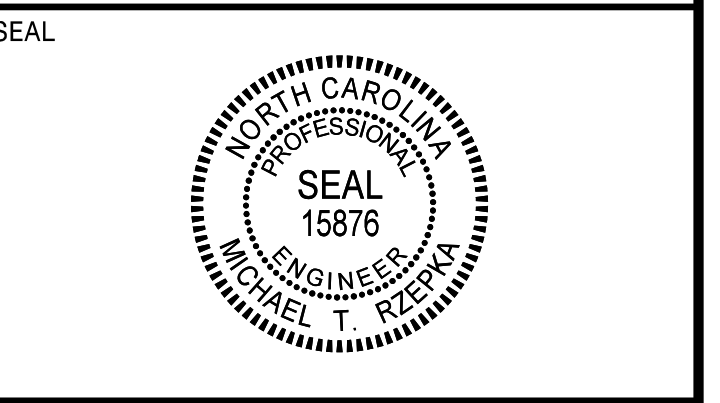

**DOCUMENT NOT CONSIDERED FINAL  
UNLESS ALL SIGNATURES COMPLETED**

401 QUANTITY REQ'D 2

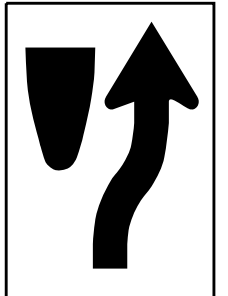

24" X 30"  
R4-7

ONE "U" POST PER SIGN

402 QUANTITY REQ'D 2

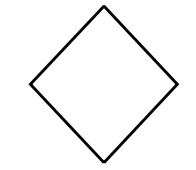

18" X 18"  
OM1-3

MOUNT BELOW SIGN 401  
IN 2 INSTALLATIONS

403 QUANTITY REQ'D 3

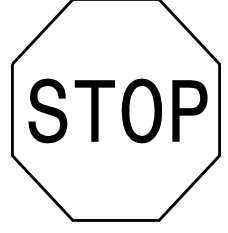

30" X 30"  
R1-1

ONE "U" POST PER SIGN, 2 LOCATIONS  
BACK-TO-BACK WITH SIGN 401, 1 LOCATION

404 QUANTITY REQ'D 2



30" X 36"  
R2-1

ONE "U" POST PER SIGN

405 QUANTITY REQ'D 3



30" X 30"  
R5-1

ONE "U" POST PER SIGN, 2 LOCATIONS  
BACK-TO-BACK WITH SIGN 403, 1 LOCATION

406 QUANTITY REQ'D 1

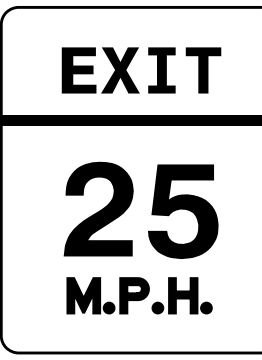

24" X 30"  
W13-2

TWO "U" POST PER SIGN

407 QUANTITY REQ'D 1



36" X 36"  
R3-7

ONE "U" POST PER SIGN

501

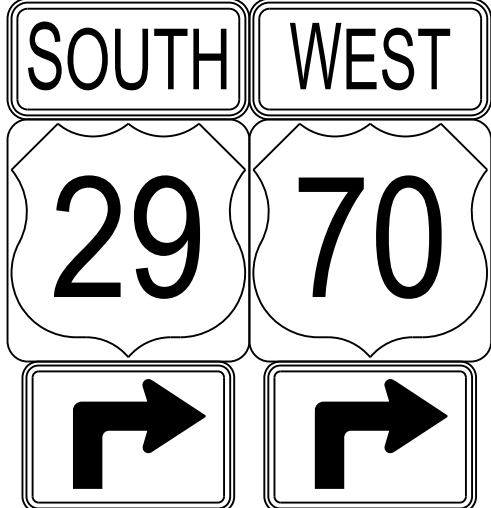

2 - 24" X 12"  
2 - 24" X 24"  
2 - 21" X 15"

502

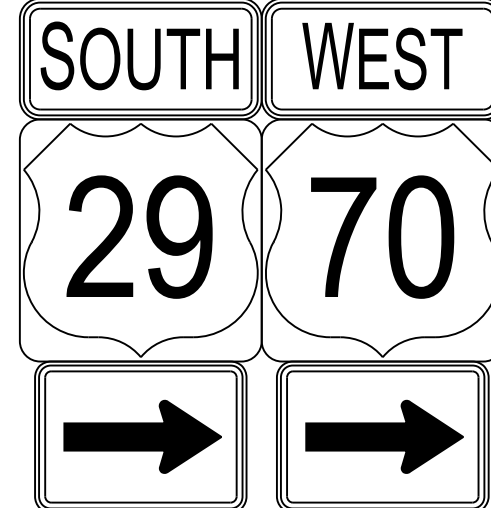

2 - 24" X 12"  
2 - 24" X 24"  
2 - 21" X 15"

503

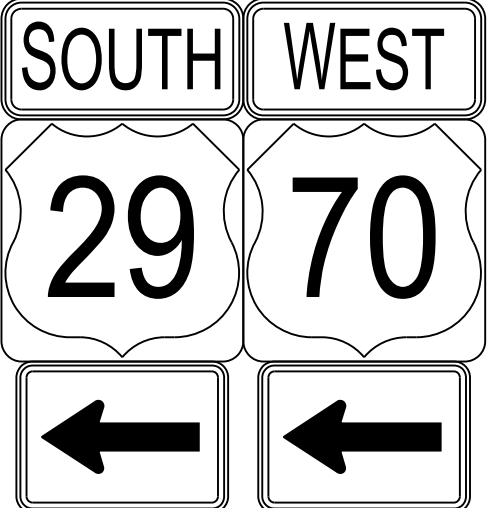

2 - 24" X 12"  
2 - 24" X 24"  
2 - 21" X 15"

504

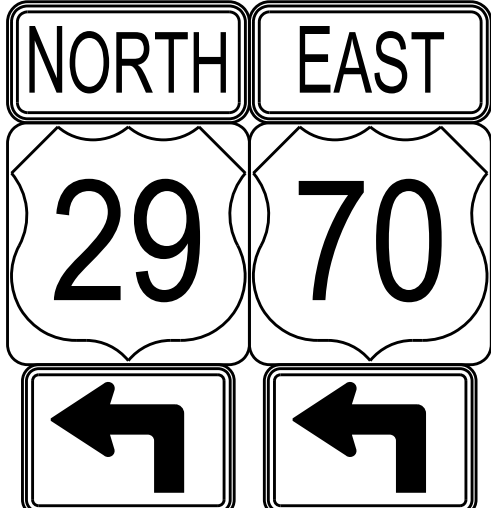

2 - 24" X 12"  
2 - 24" X 24"  
2 - 21" X 15"

505

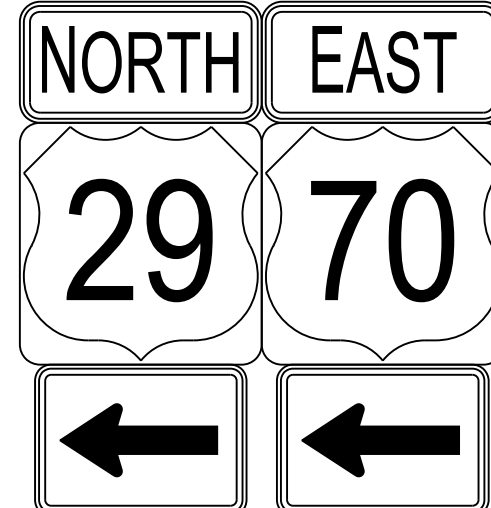

2 - 24" X 12"  
2 - 24" X 24"  
2 - 21" X 15"

506

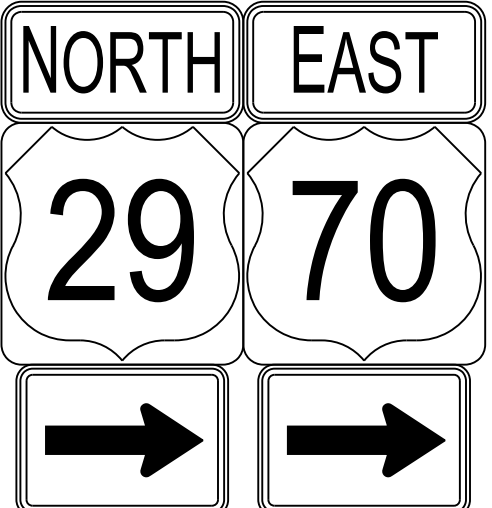

2 - 24" X 12"  
2 - 24" X 24"  
2 - 21" X 15"

507 / 508

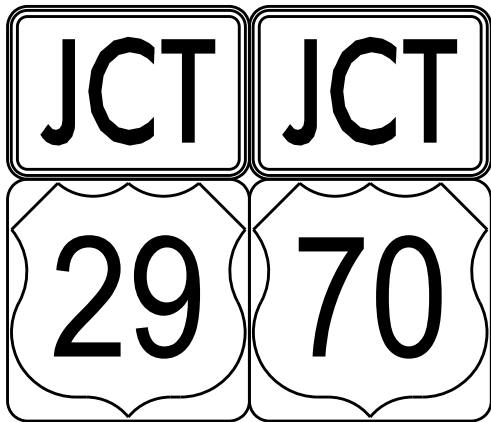

2 - 21" X 15"  
2 - 24" X 24"

**TYPE "E" SIGNS &  
TYPE "F" SIGNS**

PLOT DRIVER: NCDOT\_color\_eng\_50.pit  
USER: CHARNDEN  
FILE: p:\p\h\dr\users\01\HDR\_US\_East\_01\Documents\5705\10127116\6\_0\_CAD\_BIM\6.2\_WIP\Traffic\Signing\CADD\Signing Layout Plans\400225\_SIGN\_S02.dgn  
PENTABLE: NCDOT\_Signing.tbl  
TIME: 13:35:15  
DATE: 01/17/23

APPROVED: Michael T. Rzepka  
DATE: 1/20/2023

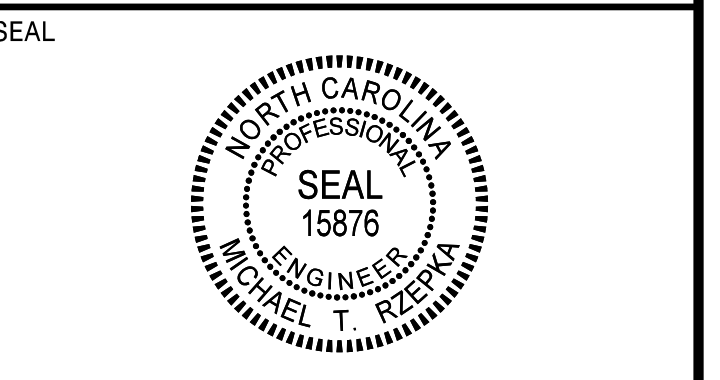

**DOCUMENT NOT CONSIDERED FINAL  
UNLESS ALL SIGNATURES COMPLETED**

SIGN NUMBER: 301 TYPE: D QUANTITY: 2 SIGN WIDTH: 5'-6" HEIGHT: 2'-6" TOTAL AREA: 13.8 Sq.Ft. BORDER TYPE: FLUSH RECESS: 0" WIDTH: 0.75" RADII: 3" NO. Z BARS: LENGTH:	BACKG COLOR: Green COPY COLOR: White <table border="1"> <tr> <th>SYMBOL</th> <th>X</th> <th>Y</th> <th>WID</th> <th>HT</th> </tr> <tr> <td>AR_Type D</td> <td>7.2</td> <td>17.8</td> <td>6</td> <td>9</td> </tr> <tr> <td>AR_Type D</td> <td>51.4</td> <td>4.7</td> <td>6</td> <td>9</td> </tr> </table> MAT'L: 0.125" (3.2 mm) ALUMINUM	SYMBOL	X	Y	WID	HT	AR_Type D	7.2	17.8	6	9	AR_Type D	51.4	4.7	6	9	DESIGN BY: R. DRAYTON PROJECT ID: 17BP.7.R.142 CHECKED BY: M. RZEPKA LOCATION: Oct 08, 2021 DIV: 7
SYMBOL	X	Y	WID	HT													
AR_Type D	7.2	17.8	6	9													
AR_Type D	51.4	4.7	6	9													

Spacing Factor is 1 unless specified otherwise

Letter spacings are to start of next letter													Series/Size Text Length
H	i	g	h	P	o	i	n	t					D 2000
19.2	5.4	1.9	4.8	3.5	6	4.6	4.6	2.2	4.1	2.4	7.2		39.6
G	r	e	e	n	s	b	o	r	o				D 2000
5.6	5.3	2.8	4.1	4.4	4.3	3.6	4.3	4.6	2.8	3.7	20.6		39.8

FILENAME: 400255\_SignDesigns NORTH CAROLINA D.O.T. SIGN DETAIL

SIGN NUMBER: 302 TYPE: D QUANTITY: 1 SIGN WIDTH: 5'-6" HEIGHT: 2'-6" TOTAL AREA: 13.8 Sq.Ft. BORDER TYPE: FLUSH RECESS: 0" WIDTH: 0.75" RADII: 3" NO. Z BARS: LENGTH:	BACKG COLOR: Green COPY COLOR: White <table border="1"> <tr> <th>SYMBOL</th> <th>X</th> <th>Y</th> <th>WID</th> <th>HT</th> </tr> <tr> <td>AR_Type D</td> <td>5.7</td> <td>17.7</td> <td>6</td> <td>9</td> </tr> <tr> <td>AR_Type D</td> <td>5.7</td> <td>4.7</td> <td>6</td> <td>9</td> </tr> </table> MAT'L: 0.125" (3.2 mm) ALUMINUM	SYMBOL	X	Y	WID	HT	AR_Type D	5.7	17.7	6	9	AR_Type D	5.7	4.7	6	9	DESIGN BY: R. DRAYTON PROJECT ID: 17BP.7.R.142 CHECKED BY: M. RZEPKA LOCATION: Jan 17, 2023 DIV: 7
SYMBOL	X	Y	WID	HT													
AR_Type D	5.7	17.7	6	9													
AR_Type D	5.7	4.7	6	9													

Spacing Factor is 1 unless specified otherwise

Letter spacings are to start of next letter													Series/Size Text Length
G	r	e	e	n	s	b	o	r	o				D 2000
20.5	5.3	2.8	4.1	4.4	4.3	3.6	4.3	4.6	2.8	3.7	5.7		39.8
H	i	g	h	P	o	i	n	t					D 2000
20.7	5.4	1.9	4.8	3.5	6	4.6	4.6	2.2	4.1	2.4	5.7		39.6

FILENAME: 400255\_SignDesigns NORTH CAROLINA D.O.T. SIGN DETAIL

PLOT DRIVER: NCDOT\_color\_eng\_50.pht  
 USER: CHARNDEN  
 FILE: p:\pwhdr\users\01\HDR\_US\_East\_01\Documents\5705\1012\1116\6\_0\_CAD\_BITMAP\6.2\_WIP\Traffic\Signing\CADD\Signing Layout Plans\400225\_SIGN\_S03\_new.dgn  
 PENTABLE: NCDOT\_Signing.tbl  
 TIME: 13:45:42  
 DATE: 01/17/23

**TYPE "D" SIGN DESIGN**

APPROVED: Michael T. Rzepka  
 DATE: 1/20/2023

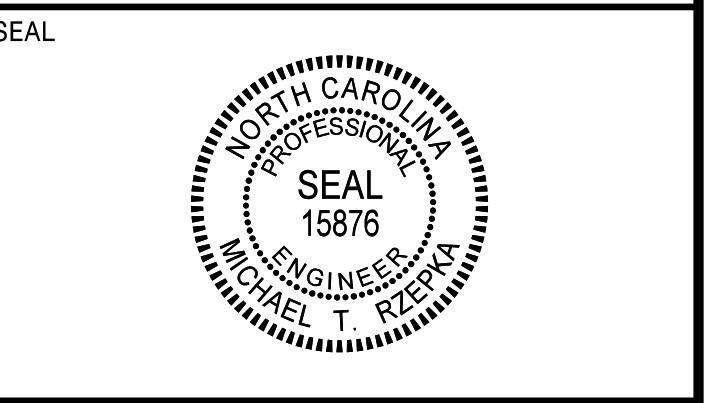

**DOCUMENT NOT CONSIDERED FINAL  
 UNLESS ALL SIGNATURES COMPLETED**

SIGN NUMBER: 303 TYPE: D QUANTITY: 1 SIGN WIDTH: 5'-6" HEIGHT: 1'-6" TOTAL AREA: 8.3 Sq.Ft. BORDER TYPE: FLUSH RECESS: 0" WIDTH: 0.75" RADII: 3" NO. Z BARS: LENGTH:	BACKG COLOR: Green COPY COLOR: White <table border="1"> <tr> <th>SYMBOL</th> <th>X</th> <th>Y</th> <th>WID</th> <th>HT</th> </tr> <tr> <td>AR_Type D</td> <td>5.6</td> <td>6</td> <td>6</td> <td>9</td> </tr> </table> MAT'L: 0.125" (3.2 mm) ALUMINUM	SYMBOL	X	Y	WID	HT	AR_Type D	5.6	6	6	9	DESIGN BY: R. DRAYTON PROJECT ID: 17BP.7.R.142 CHECKED BY: M. RZEPKA DIV: 7 Jan 17, 2023
SYMBOL	X	Y	WID	HT								
AR_Type D	5.6	6	6	9								

BORDER R=3" TH=0.75"

Spacing Factor is 1 unless specified otherwise

Letter spacings are to start of next letter												Series/Size	
												Text Length	
	G	r	e	e	n	s	b	o	r	o		D 2000	
	20.6	5.3	2.8	4.1	4.4	4.3	3.6	4.3	4.6	2.8	3.7	5.6	39.8

USE NOTES: 1,2

- Legend and border(except those that are colored black) shall be direct applied Grade C sheeting.
- Background shall be Grade C reflective sheeting.

FILENAME: 400255\_SignDesigns NORTH CAROLINA D.O.T. SIGN DETAIL

SIGN NUMBER: 304 TYPE: D QUANTITY: 1 SIGN WIDTH: 5'-6" HEIGHT: 1'-6" TOTAL AREA: 8.3 Sq.Ft. BORDER TYPE: FLUSH RECESS: 0" WIDTH: 0.75" RADII: 3" NO. Z BARS: LENGTH:	BACKG COLOR: Green COPY COLOR: White <table border="1"> <tr> <th>SYMBOL</th> <th>X</th> <th>Y</th> <th>WID</th> <th>HT</th> </tr> <tr> <td>AR_Type D</td> <td>51.3</td> <td>6</td> <td>6</td> <td>9</td> </tr> </table> MAT'L: 0.125" (3.2 mm) ALUMINUM	SYMBOL	X	Y	WID	HT	AR_Type D	51.3	6	6	9	DESIGN BY: R. DRAYTON PROJECT ID: 17BP.7.R.142 CHECKED BY: M. RZEPKA DIV: 7 Jan 17, 2023
SYMBOL	X	Y	WID	HT								
AR_Type D	51.3	6	6	9								

BORDER R=3" TH=0.75"

Spacing Factor is 1 unless specified otherwise

Letter spacings are to start of next letter												Series/Size	
												Text Length	
	H	i	g	h	P	o	i	n	t			D 2000	
	5.7	5.4	1.9	4.8	3.5	6	4.6	4.6	2.2	4.1	2.4	20.7	39.6

USE NOTES: 1,2

- Legend and border(except those that are colored black) shall be direct applied Grade C sheeting.
- Background shall be Grade C reflective sheeting.

FILENAME: 400255\_SignDesigns NORTH CAROLINA D.O.T. SIGN DETAIL

PLOT DRIVER: NCDOT\_color\_eng\_50.ppt  
 USER: CHARNDEN  
 FILE: p:\pwhdr\users\01\HDR\_US\_East\_01\Documents\5705\1012\116\6\_0\_CAD\_BIM\6.2\_WIP\Traffic\Signing\CADD\Signing Layout Plans\400225\_SIGN\_S03\_new.dgn  
 PENTABLE: NCDOT\_Signing.tbl  
 TIME: 13:46:04  
 DATE: 01/17/23

**TYPE "D" SIGN DESIGN**

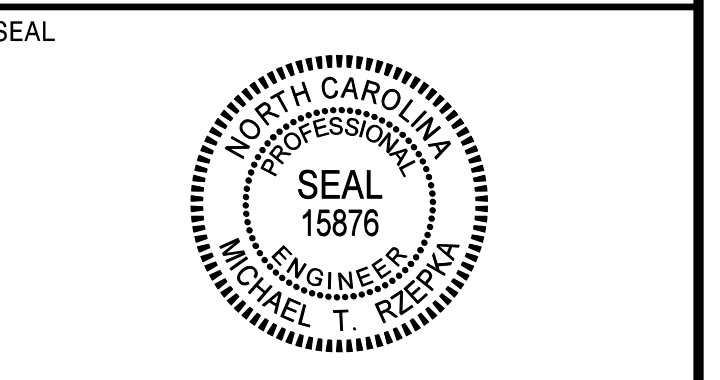

**DOCUMENT NOT CONSIDERED FINAL  
UNLESS ALL SIGNATURES COMPLETED**

PLOT DRIVER: NCDOT\_color\_eng\_50.pit  
USER: CHARNDEN  
DATE: 01/17/23  
TIME: 13:43:41  
FILE: p:\dwg\hdr\users\01\hdr\US\_East\01\Documents\5705\1012\116\6.0\_CAD\_BIM\6.2\_WIP\Traffic\Signing\CADD\Signing Layout Plans\400225\_SIGN\_S04.dgn

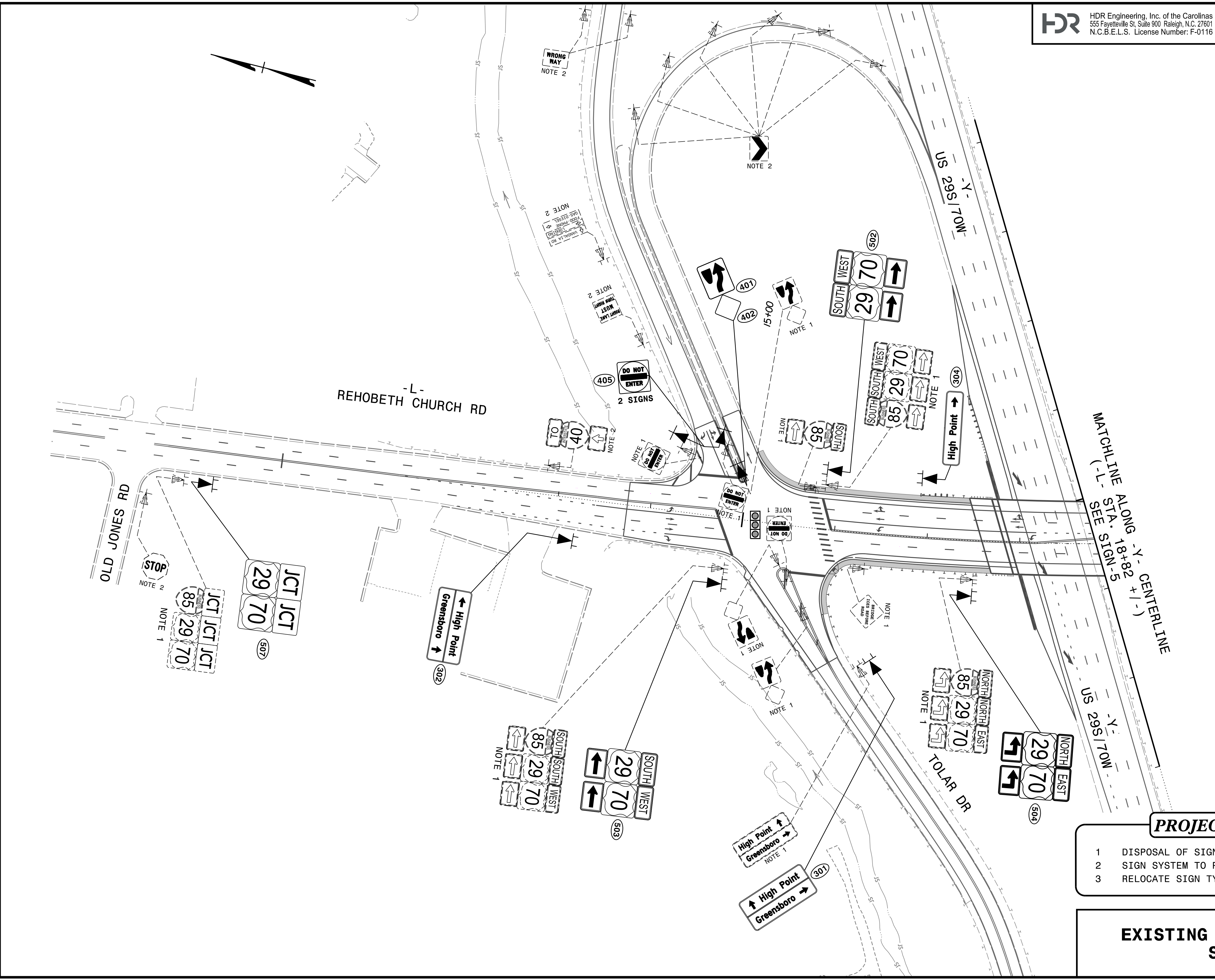

MATCHLINE ALONG  
(-L- STA. 18+82 +1-)  
SEE SIGN-5  
US 29S/70W  
-Y- CENTERLINE

- PROJECT NOTES**
- 1 DISPOSAL OF SIGN SYSTEM, U-CHANNEL
  - 2 SIGN SYSTEM TO REMAIN
  - 3 RELOCATE SIGN TYPE D

**EXISTING AND PROPOSED  
SIGNS**

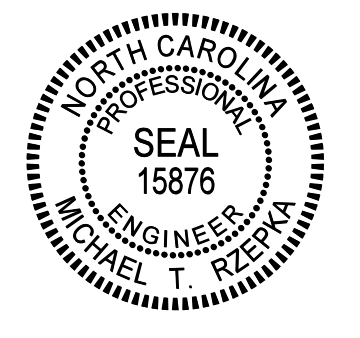

**DOCUMENT NOT CONSIDERED FINAL  
UNLESS ALL SIGNATURES COMPLETED**

PLOT DRIVER: NCDOT\_color\_eng\_50.pit  
USER: CHARNDEN  
DATE: 01/17/23  
FILE: p:\dwg\hdr\users\01\HDR\_US\_East\01\Documents\5705\10127116\6.0\_CAD\_BIM\6.2\_WIP\Traffic\Signing\CADD\Signing Layout Plans\400225\_SIGN\_S05.dgn

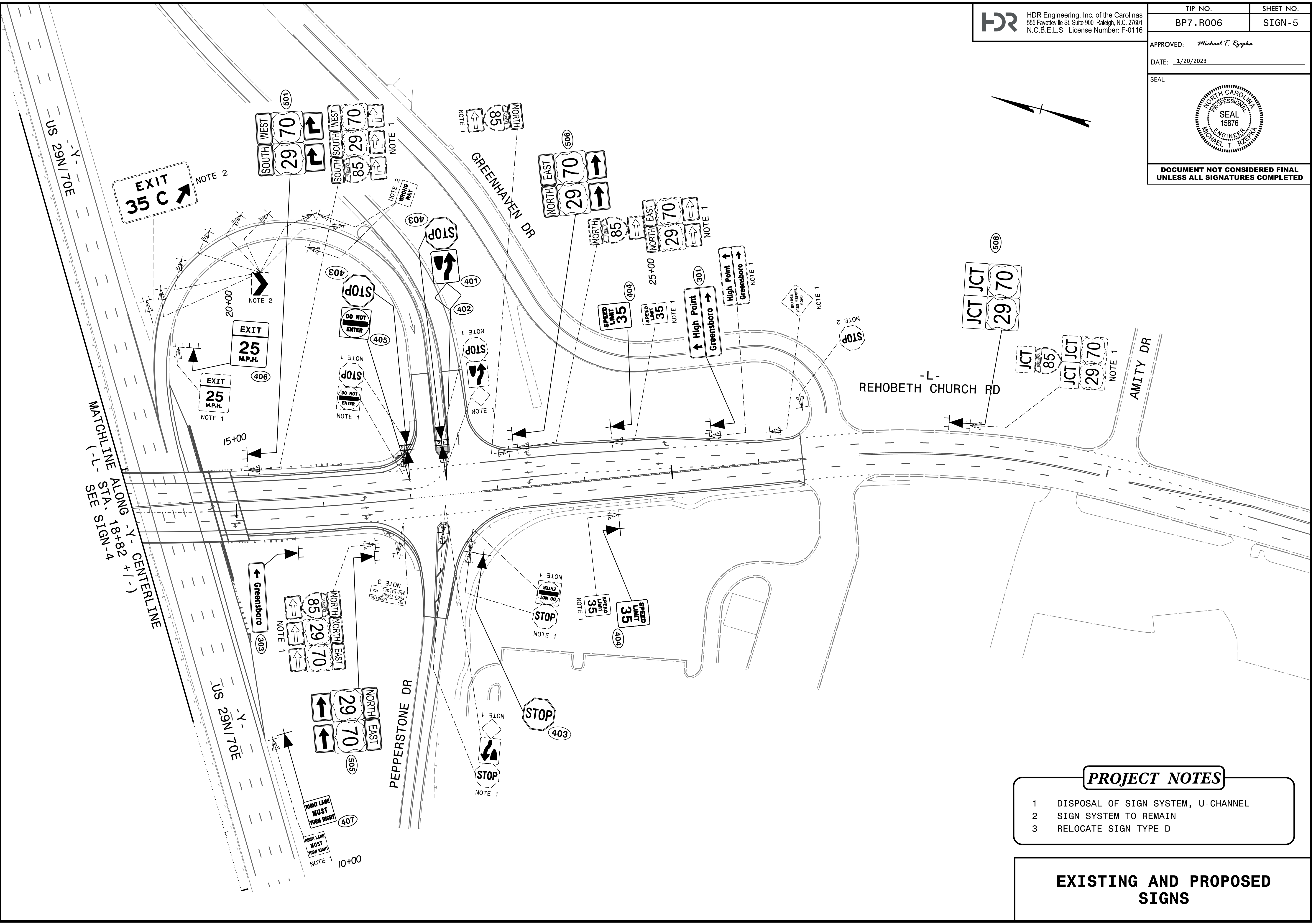

MATCHLINE ALONG -Y- CENTERLINE  
STA. 18+82 +/-  
SEE SIGN-4

**PROJECT NOTES**

- 1 DISPOSAL OF SIGN SYSTEM, U-CHANNEL
- 2 SIGN SYSTEM TO REMAIN
- 3 RELOCATE SIGN TYPE D

**EXISTING AND PROPOSED  
SIGNS**