

UTILITIES BY OTHERS

ALL PROPOSED UTILITY WORK SHOWN ON THIS SHEET WILL BE DONE BY OTHERS. NO PAYMENT WILL BE MADE TO THE CONTRACTOR FOR PROPOSED UTILITY WORK SHOWN ON THIS SHEET.

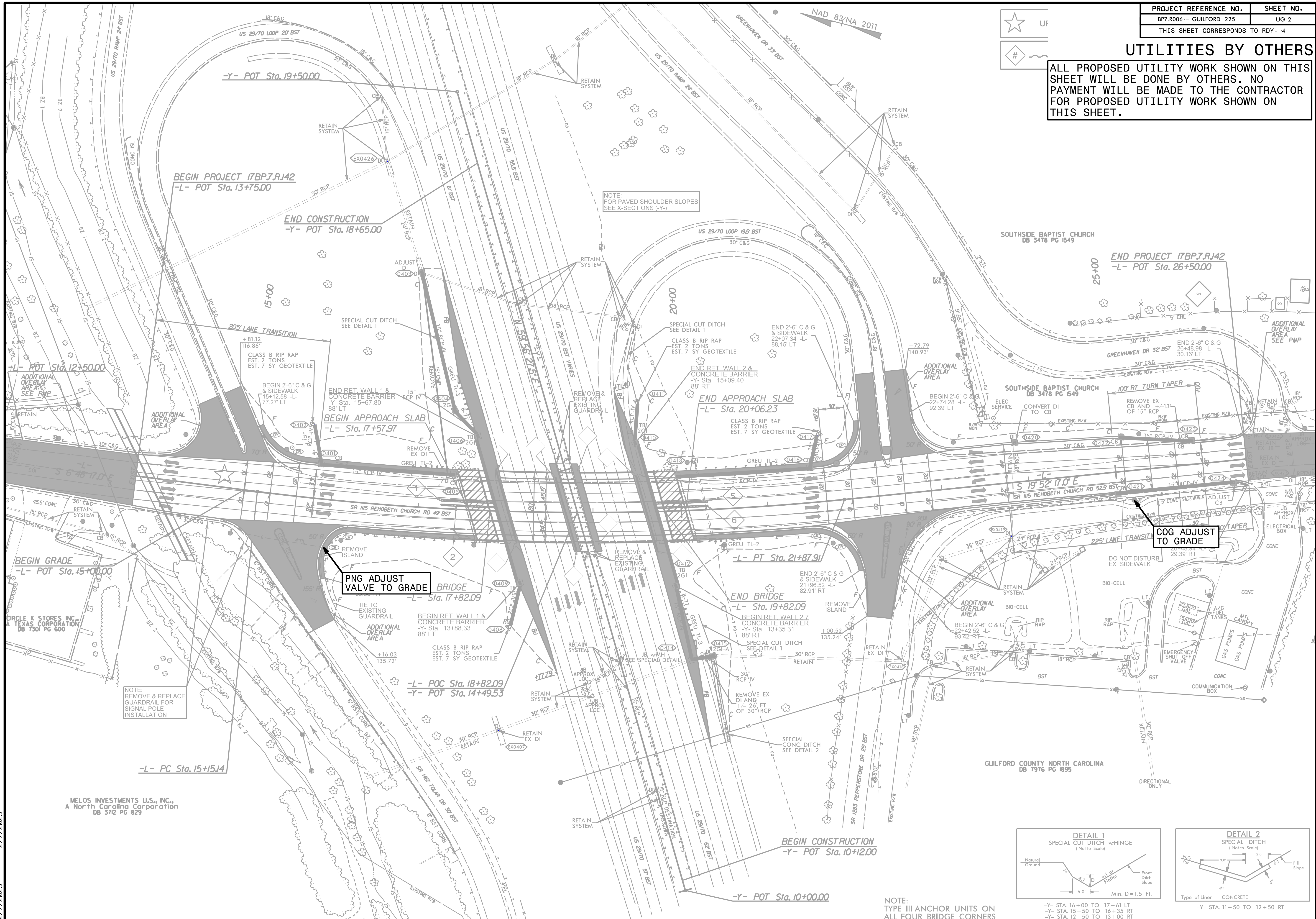

NOTE:
FOR PAVED SHOULDER SLOPES
SEE X-SECTIONS (-Y-)

COG ADJUST
TO GRADE

PNG ADJUST
VALVE TO GRADE

NOTE:
REMOVE & REPLACE
GUARDRAIL FOR
SIGNAL POLE
INSTALLATION

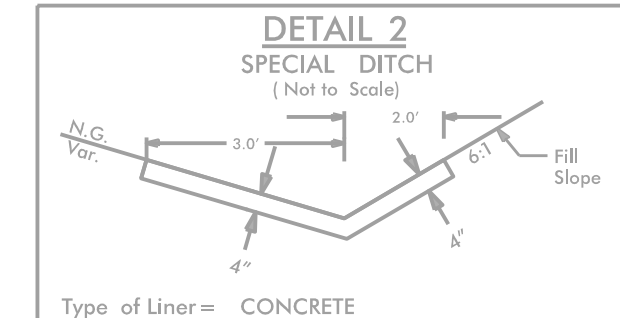
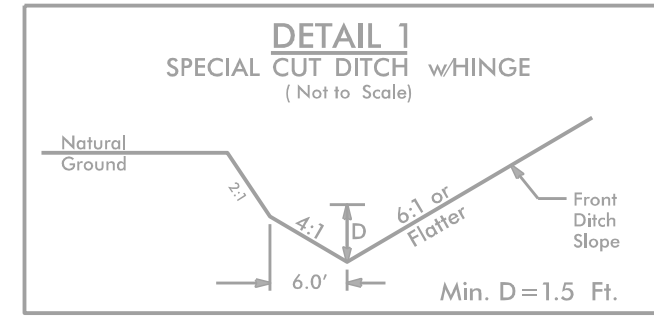

NOTE:
TYPE III ANCHOR UNITS ON
ALL FOUR BRIDGE CORNERS

-Y- STA. 16+00 TO 17+61 LT
-Y- STA. 15+50 TO 16+35 RT
-Y- STA. 12+50 TO 13+00 RT
-Y- STA. 11+50 TO 12+50 RT

3:40:48 PM
 \\400225-rdy-psh.dgn
 2/7/2023

MELOS INVESTMENTS U.S., INC.
A North Carolina Corporation
DB 372 PG 829