

SPAN A
SPAN B

BOTTOM OF CAP

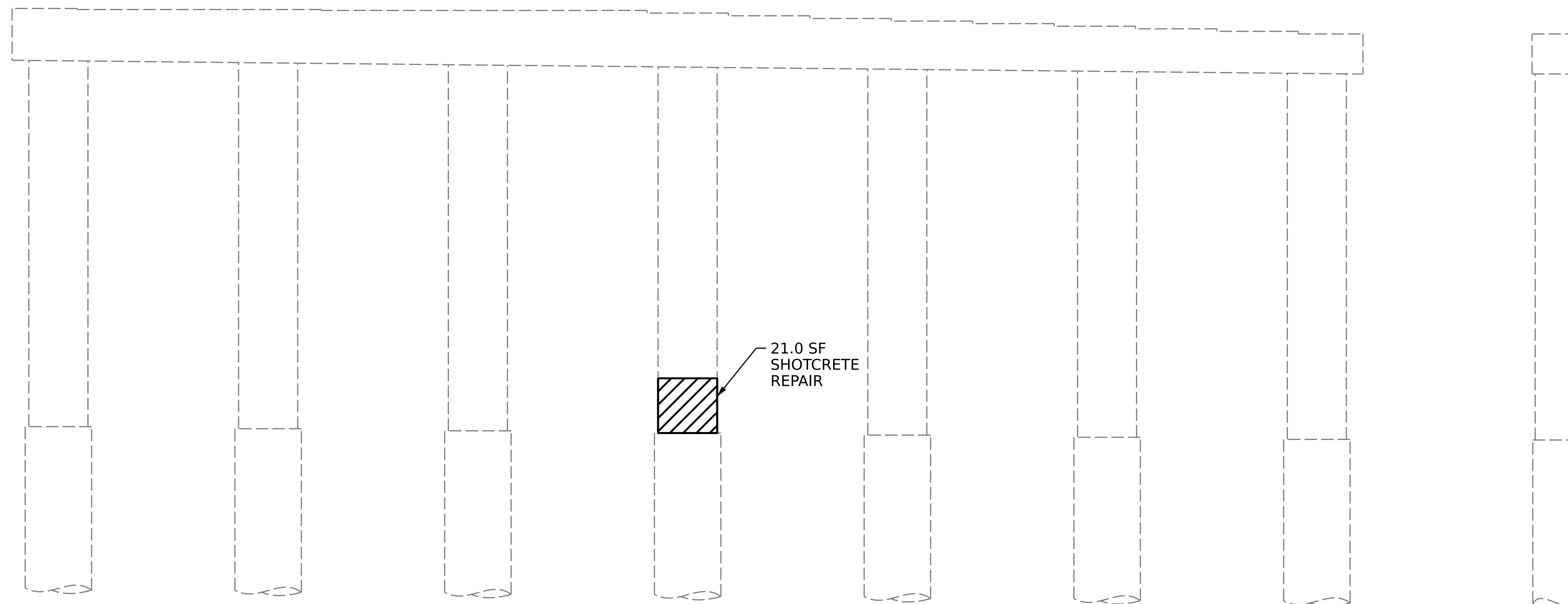

ELEVATION

END VIEW

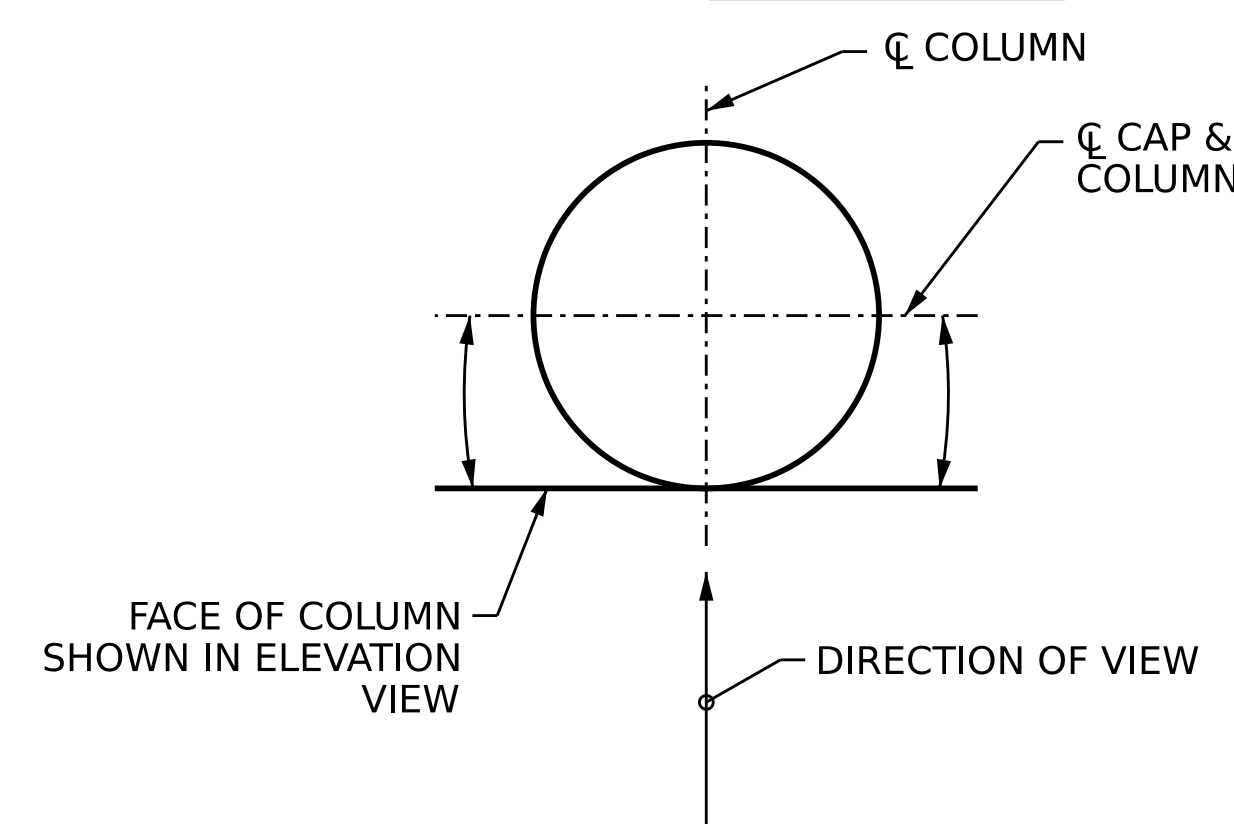

UNWRAPPED COLUMN FACE DETAIL

SUBSTRUCTURE REPAIR QUANTITY TABLE

BENT 1	QUANTITIES			
	ESTIMATE		ACTUAL	
SHOTCRETE REPAIRS	AREA SF	VOLUME CF	AREA SF	VOLUME CF
CAP	0	0		
COLUMN	21.0	10.5		
CONCRETE REPAIRS	AREA SF	VOLUME CF	AREA SF	VOLUME CF
CAP	0	0		
COLUMN	0	0		
EPOXY RESIN INJECTION		LINEAR FT		LINEAR FT
CAP		0		
COLUMN		0		

VALUES IN CHART REPRESENT ESTIMATED REPAIR TOTALS AFTER REMOVAL OF UNSOUND CONCRETE, MIN. OF 1" BEHIND REBAR AND MIN. 2" CLEAR TO SAWCUT. SEE REPAIR DETAILS.

NOTES

REPAIR LOCATIONS AND ESTIMATE OF QUANTITIES ARE GIVEN BASED ON THE BEST INFORMATION AVAILABLE. IF ADDITIONAL REPAIRS NOT SHOWN ON THE DRAWINGS ARE DEEMED NECESSARY BY THE ENGINEER, THE ENGINEER SHALL NOTE ON THE DRAWINGS THE APPROXIMATE LOCATION AND DESCRIPTION OF THE REPAIRS AND ENTER THE ACTUAL QUANTITIES INTO THE REPAIR QUANTITY TABLE.

CLEAN AND REMOVE DEBRIS FROM THE TOP OF THE CAP AND APPLY EPOXY PROTECTIVE COATING. EPOXY COATING SHALL BE APPLIED TO THE TOP SURFACE OF THE CAP. THE CONTRACTOR SHALL NOT COAT THE AREA OF THE CAP BENEATH THE MASONRY PLATES. FOR EPOXY COATING, SEE SPECIAL PROVISIONS.

CONCRETE REPAIRS MAYBE SUBSTITUTED IN LIEU OF SHOTCRETE REPAIRS WITH THE APPROVAL OF THE ENGINEER.

- SHOTCRETE REPAIR AREA
- CONCRETE REPAIR AREA
- EPOXY RESIN INJECTION

PROJECT NO. **15BPR.59**
WAKE COUNTY
 BRIDGE NO. **911084**

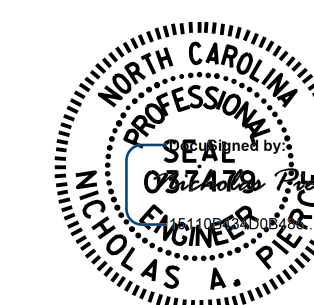

12/08/2022

STATE OF NORTH CAROLINA
 DEPARTMENT OF TRANSPORTATION
 RALEIGH
 SUBSTRUCTURE REPAIR

**BENT 1
 SPAN B FACE**

REVISIONS						SHEET NO.
NO.	BY:	DATE:	NO.	BY:	DATE:	S4-14
1			3			TOTAL SHEETS
2			4			21

DOCUMENT NOT CONSIDERED FINAL UNLESS ALL SIGNATURES COMPLETED

DRAWN BY : D.A. CANTRELL DATE : 03/2021
 CHECKED BY : A.Y. GODFREY DATE : 10/2022
 DESIGN ENGINEER OF RECORD: N.A. PIERCE DATE : 12/2022