

NOTES

REPAIR LOCATIONS AND ESTIMATE OF QUANTITIES ARE BASED ON THE BEST INFORMATION AVAILABLE. IF ADDITIONAL REPAIRS NOT SHOWN ON THE DRAWINGS ARE DEEMED NECESSARY BY THE ENGINEER, THE ENGINEER SHALL NOTE ON THE DRAWINGS THE APPROXIMATE LOCATION AND DESCRIPTION OF THE REPAIRS AND ENTER THE ACTUAL QUANTITIES INTO THE SUBSTRUCTURE REPAIR QUANTITY TABLE.



CLEAN AND REMOVE DEBRIS FROM THE TOP OF THE CAP AND APPLY EPOXY PROTECTIVE COATING. EPOXY COATING SHALL BE APPLIED TO THE TOP SURFACE OF THE CAP. THE CONTRACTOR SHALL NOT COAT THE AREA OF THE CAP BENEATH THE MASONRY PLATES.

CONCRETE REPAIRS MAYBE SUBSTITUTED IN LIEU OF SHOTCRETE REPAIRS WITH THE APPROVAL OF THE ENGINEER.

REMOVAL OF DEBRIS AND DISPOSAL OF EXISTING JOINT SEALANT MATERIAL FROM SLOPE PROTECTION PRIOR TO PLACEMENT OF BACKER ROD AND POURABLE SILICONE JOINT SEALANT SHALL BE CONSIDERED INCIDENTAL TO CONSTRUCTION.

POURABLE SILICONE JOINT SEALANT SHALL BE INSTALLED AS PER THE MANUFACTURER'S RECOMMENDATIONS.

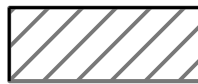
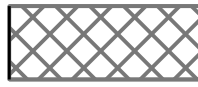
THE INSTALLED POURABLE SILICONE JOINT SEALANT SHALL BE WATER TIGHT.

-  SHOTCRETE REPAIR AREA
-  CONCRETE REPAIR AREA
-  EPOXY RESIN INJECTION

SUBSTRUCTURE REPAIR QUANTITY TABLE

END BENT 2	QUANTITIES			
	ESTIMATE		ACTUAL	
SHOTCRETE REPAIRS	AREA SF	VOLUME CF	AREA SF	VOLUME CF
CAP	0	0		
BACKWALL	0	0		
CONCRETE REPAIRS	AREA SF	VOLUME CF	AREA SF	VOLUME CF
CAP	0	0		
BACKWALL	0	0		
EPOXY RESIN INJECTION		LINEAR FT		LINEAR FT
CAP		0		
BACKWALL		0		
EPOXY COATING		AREA SF		AREA SF
CAP		1052		
POURABLE SILICONE JT. SEALANT		LINEAR FT		LINEAR FT
JOINT		630		

VALUES IN CHART REPRESENT ESTIMATED REPAIR TOTALS AFTER REMOVAL OF UNSOUND CONCRETE, MIN. OF 1" BEHIND REBAR AND MIN. 1" CLEAR TO SAWCUT. SEE REPAIR DETAILS.

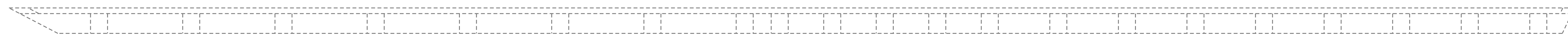

PLAN



ELEVATION

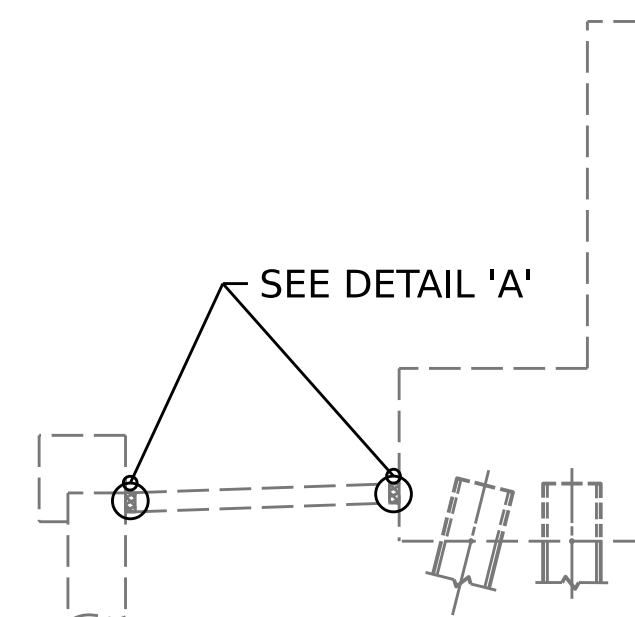

SECTION X-X

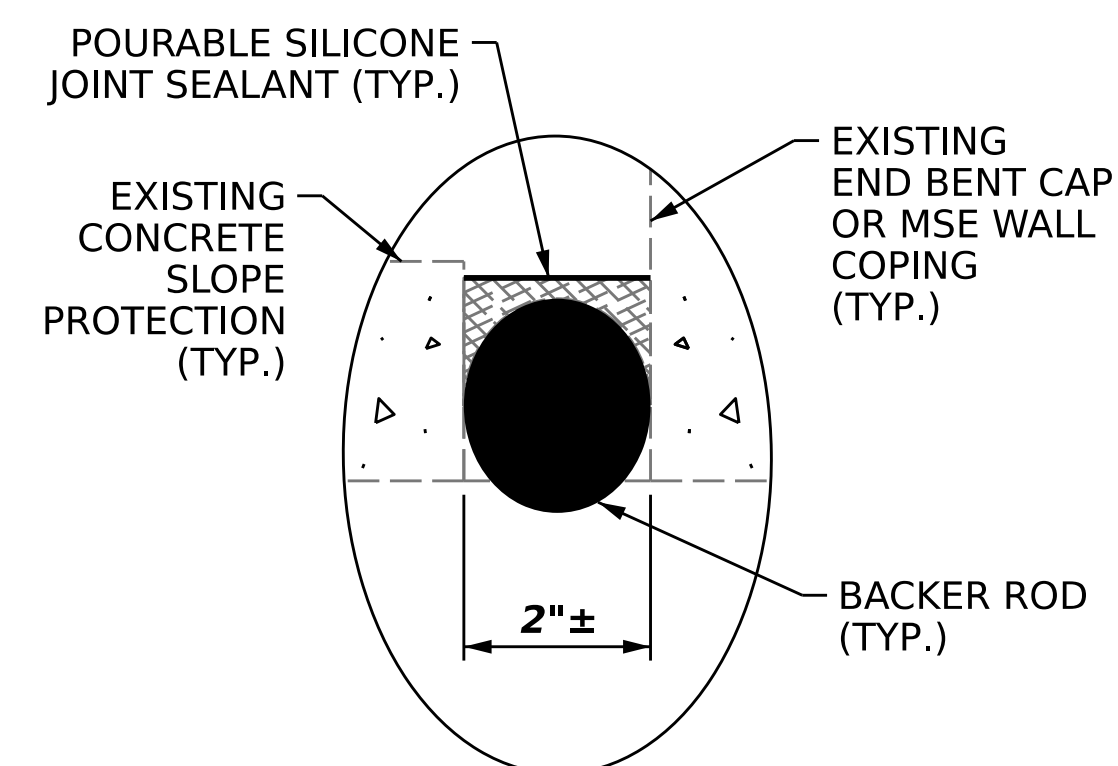

DETAIL 'A'

PROJECT NO. **15BPR.59**
DURHAM COUNTY
BRIDGE NO. **310306**



STATE OF NORTH CAROLINA
DEPARTMENT OF TRANSPORTATION
RALEIGH
SUBSTRUCTURE REPAIR
END BENT 2

DOCUMENT NOT CONSIDERED FINAL UNLESS ALL SIGNATURES COMPLETED

REVISIONS						SHEET NO.
NO.	BY:	DATE:	NO.	BY:	DATE:	SHEET NO.
1			3			S1-14
2			4			TOTAL SHEETS 15

DRAWN BY : N.A. PIERCE DATE : 04/2022
CHECKED BY : A.Y.GODFREY DATE : 10/2022
DESIGN ENGINEER OF RECORD: N.A. PIERCE DATE : 12/2022