

**This electronic collection of documents is provided
for the convenience of the user
and is Not a Certified Document –**

**The documents contained herein were originally issued
and sealed by the individuals whose names and license
numbers appear on each page, on the dates appearing
with their signature on that page.**

**This file or an individual page
shall not be considered a certified document.**

10/5/2022
 R:\Trg\Tg\Delineation\R-5751_pmp.tsh.dgn
 User:bdondj

CONTRACT:

T.I.P.: R-5751

STATE OF NORTH CAROLINA
 DEPARTMENT OF TRANSPORTATION

PAVEMENT MARKING PLAN
 ROBESON COUNTY

TIP NO. R-5751	SHEET NO. PMP-1
APPROVED: _____	
DATE: _____	
	
DOCUMENT NOT CONSIDERED FINAL UNLESS ALL SIGNATURES COMPLETED	

INDEX

SHEET NO.	DESCRIPTION
PMP-1	PAVEMENT MARKING PLAN TITLE AND SCHEDULE SHEET
PMP-2 THRU PMP-9	PAVEMENT MARKING DETAIL

GENERAL NOTES

THE FOLLOWING GENERAL NOTES APPLY AT ALL TIMES FOR THE DURATION OF THE CONSTRUCTION PROJECT, EXCEPT WHEN OTHERWISE NOTED IN THE PLAN, OR DIRECTED BY THE ENGINEER.

A) INSTALL PAVEMENT MARKINGS AND PAVEMENT MARKERS ON THE FINAL SURFACE AS FOLLOWS:

ROAD NAME	MARKING	MARKER
ALL ROADS	THERMOPLASTIC	PERMANENT RAISED
BRIDGE	POLYUREA	

B) TIE PROPOSED PAVEMENT MARKING LINES TO EXISTING PAVEMENT MARKING LINES.

C) REMOVE/REPLACE ANY CONFLICTING/DAMAGED PAVEMENT MARKINGS AND MARKERS.

D) PASSING ZONES WILL BE DETERMINED IN THE FIELD AND MUST BE APPROVED BY THE ENGINEER.

E) STOP BAR LOCATION AT NON-SIGNALIZED INTERSECTIONS MAY BE ADJUSTED AS DIRECTED BY THE ENGINEER.

F) REMOVE ALL RESIDUE AND SURFACE LAITANCE BY ACCEPTABLE METHODS ON CONCRETE BRIDGE DECKS PRIOR TO PLACING THERMOPLASTIC PAVEMENT MARKING MATERIAL.

G) UNLESS OTHERWISE SPECIFIED, HEATED-IN-PLACE THERMOPLASTIC MAY BE USED IN LIEU OF EXTRUDED THERMOPLASTIC FOR STOP BARS, SYMBOLS, CHARACTERS AND DIAGONALS. IF HEATED-IN-PLACE IS USED, IT SHALL BE PAID FOR USING THE EXTRUDED THERMOPLASTIC PAY ITEM.

ROADWAY STANDARD DRAWING

THE FOLLOWING ROADWAY STANDARDS AS APPEAR IN "ROADWAY STANDARD DRAWINGS" - PROJECT SERVICES UNIT - N.C. DEPARTMENT OF TRANSPORTATION - RALEIGH, N.C., DATED JANUARY 2018 ARE APPLICABLE TO THIS PROJECT AND BY REFERENCE HEREBY ARE CONSIDERED A PART OF THESE PLANS:

STD. NO.	TITLE
1205.01	PAVEMENT MARKINGS - LINE TYPES AND OFFSETS
1205.02	PAVEMENT MARKINGS - TWO-LANE AND MULTILANE ROADWAYS
1205.03	PAVEMENT MARKINGS - EXIT AND ENTRANCE RAMPS
1205.04	PAVEMENT MARKINGS - INTERSECTIONS
1205.12	PAVEMENT MARKINGS - BRIDGES
1205.14	PAVEMENT MARKINGS - ROUNDABOUTS
1250.01	RAISED PAVEMENT MARKERS - INSTALLATION SPACING
1251.01	RAISED PAVEMENT MARKERS - PERMANENT AND TEMPORARY
1261.01	GUARDRAIL AND BARRIER DELINEATORS - INSTALLATION SPACING
1261.02	GUARDRAIL AND BARRIER DELINEATORS - TYPES AND MOUNTING
1262.01	GUARDRAIL END DELINEATION
1264.01	OBJECT MARKERS - TYPES
1264.02	OBJECT MARKERS - INSTALLATION

PAVEMENT MARKING SCHEDULE

T20	WHITE EDGELINE	THERMOPLASTIC (6", 90 MIL)	T61	24" WHITE STOPBAR	THERMOPLASTIC (90 MIL)
T22	10' WHITE SKIP	THERMOPLASTIC (6", 90 MIL)	T79	MERGE ARROW	THERMOPLASTIC (90 MIL)
T23	3'-9'/SP WHITE MINISKIP	THERMOPLASTIC (6", 90 MIL)	T103	24" YIELD LINE TRIANGLE	THERMOPLASTIC (90 MIL)
T24	2'-6'/SP WHITE MINISKIP	THERMOPLASTIC (6", 90 MIL)	T112	FISH-HOOK RIGHT/STRAIGHT ARROW	THERMOPLASTIC (90 MIL)
T30	YELLOW EDGELINE	THERMOPLASTIC (6", 90 MIL)	T117	FISH-HOOK W/CIRCLE LEFT/STRAIGHT ARROW	THERMOPLASTIC (90 MIL)
T31	YELLOW SINGLE CENTER	THERMOPLASTIC (6", 90 MIL)	T118	FISH-HOOK W/CIRCLE LEFT/RIGHT/STRAIGHT ARROW	THERMOPLASTIC (90 MIL)
T32	10' YELLOW SKIP	THERMOPLASTIC (6", 90 MIL)	V20	WHITE EDGELINE	POLYUREA (6", 20 MIL)
T33	YELLOW DOUBLE CENTER	THERMOPLASTIC (6", 90 MIL)	V33	YELLOW DOUBLE CENTER	POLYUREA (6", 20 MIL)
T50	WHITE GORELINE	THERMOPLASTIC (12", 90 MIL)			
T55	3'-3'/SP WHITE MINISKIP	THERMOPLASTIC (12", 90 MIL)			

N.C.D.O.T. CONTACT INFORMATION

AYMAN I. ALQUDWAH, PE SIGNING AND DELINEATION REGIONAL ENGINEER
 _____ SIGNING AND DELINEATION PROJECT DESIGN ENGINEER

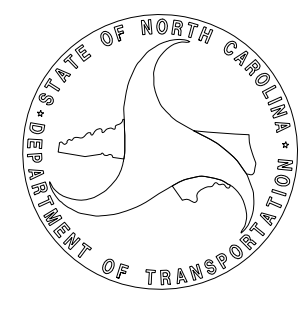

PLAN PREPARED BY: RS&H

DREW MORROW, PE PROJECT ENGINEER
JARED BOND, PE PROJECT DESIGNER



TIP NO. R-5751	SHEET NO. PMP-2
APPROVED: _____	
DATE: _____	
SEAL	
	
DOCUMENT NOT CONSIDERED FINAL UNLESS ALL SIGNATURES COMPLETED	

NAD 83/NA 2011

-L- 15

-L- 20

-L- 25

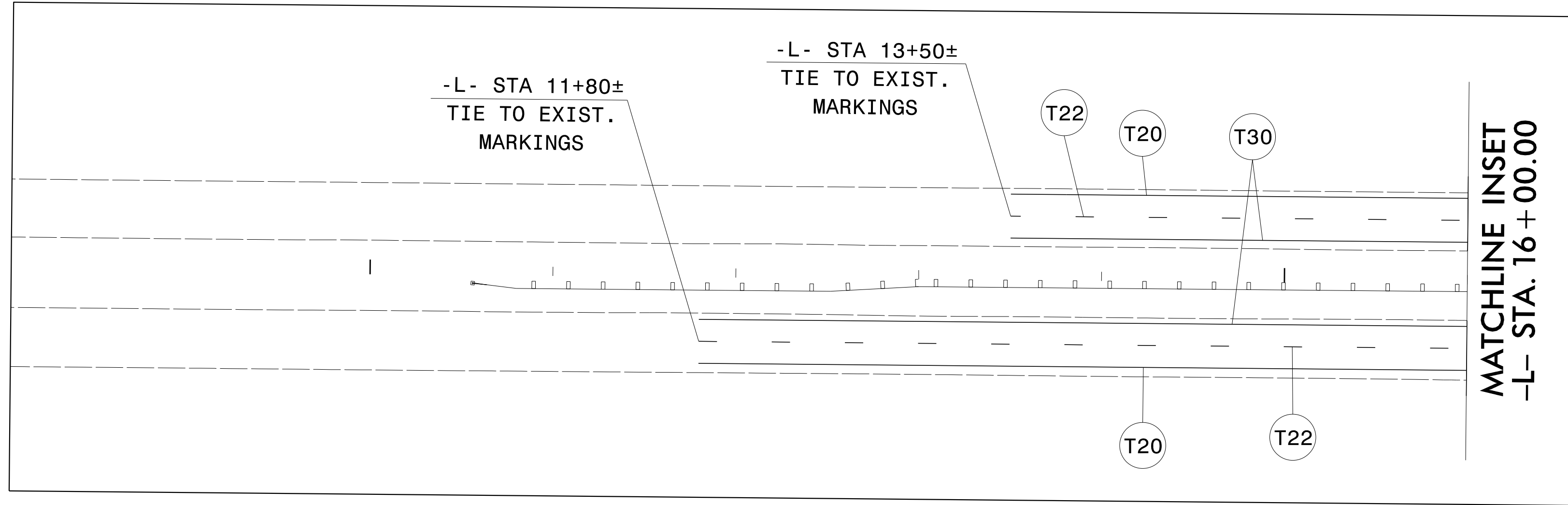
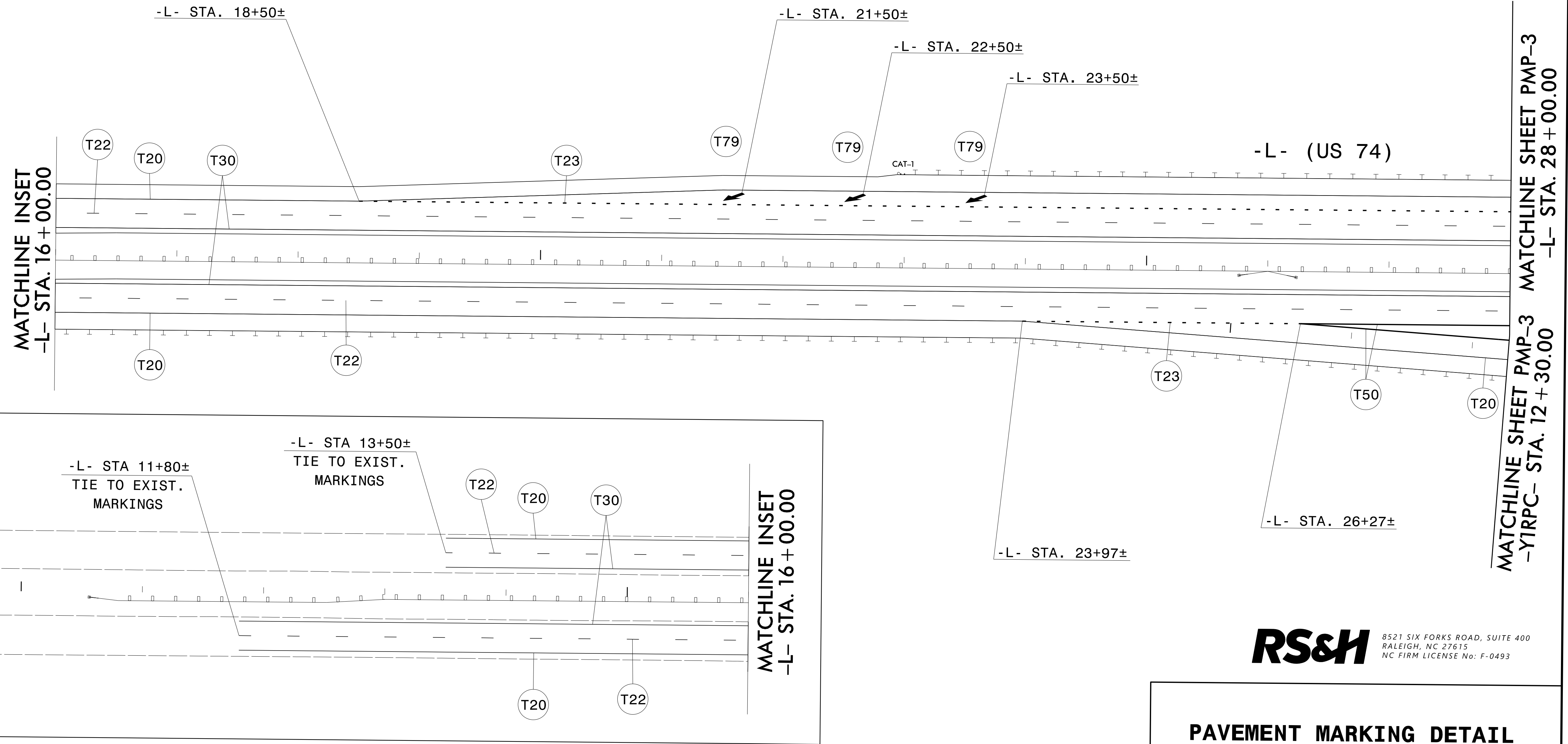

MATCHLINE SHEET PMP-3
 -L- STA. 28 + 00.00
 MATCHLINE SHEET PMP-3
 -YIRPC- STA. 12 + 30.00

RS&H 8521 SIX FORKS ROAD, SUITE 400
 RALEIGH, NC 27615
 NC FIRM LICENSE No: F-0493

PAVEMENT MARKING DETAIL

10/5/2022
 R:\Trcf\Fic\Delineation\NR-5751_pmp_dtl_02.dgn
 User:Rbondj

10/27/2022
R:\Traffic\Delinecton\R-5751_pmp.dtl.03.dgn
User:Bondu

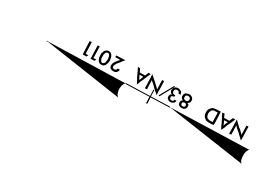

TIP NO. R-5751	SHEET NO. PMP-3
APPROVED: _____	
DATE: _____	
SEAL	
DOCUMENT NOT CONSIDERED FINAL UNLESS ALL SIGNATURES COMPLETED	

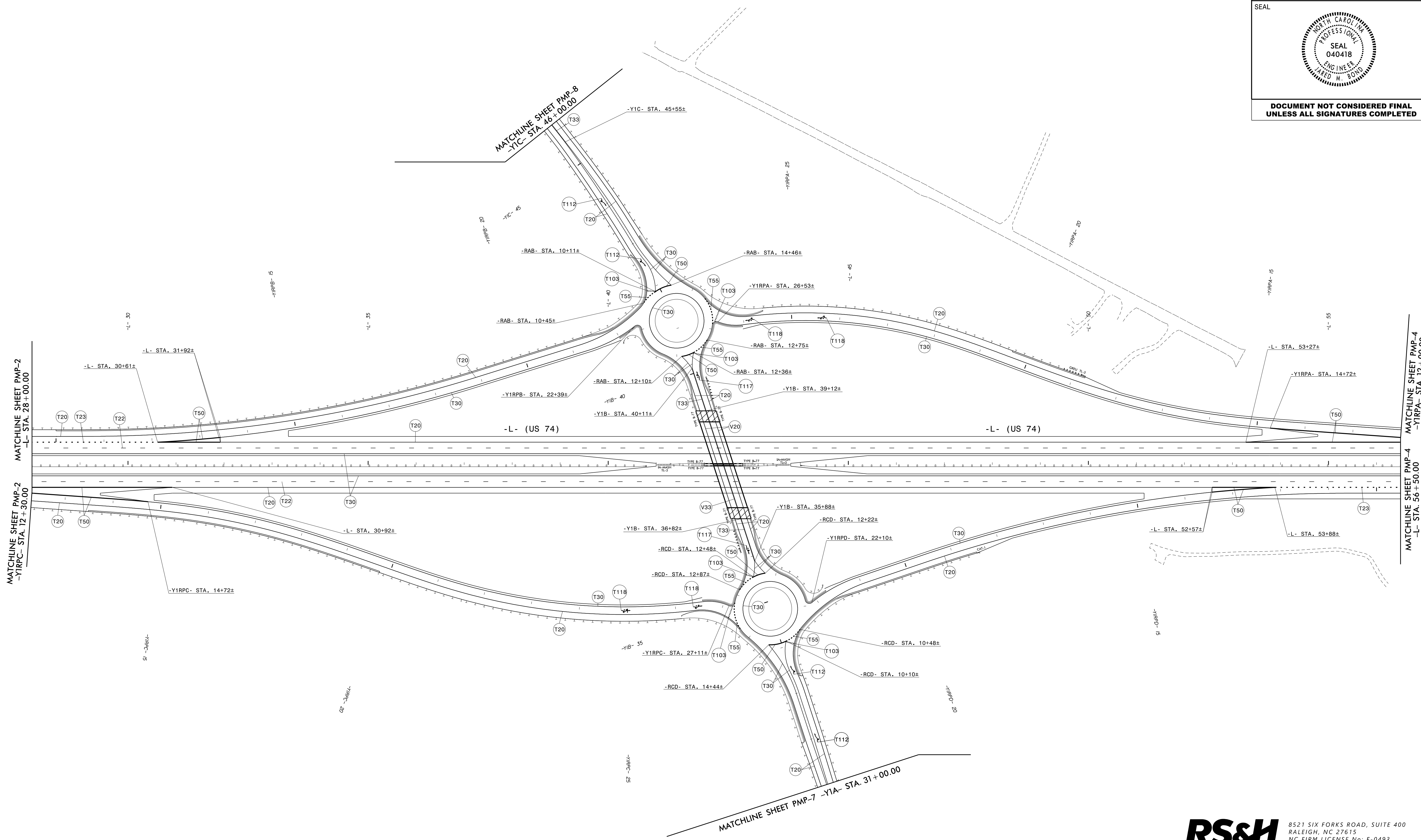

RS&H 8521 SIX FORKS ROAD, SUITE 400
RALEIGH, NC 27615
NC FIRM LICENSE No: F-0493

PAVEMENT MARKING DETAIL

TIP NO. R-5751	SHEET NO. PMP-4
APPROVED: _____	
DATE: _____	
SEAL	
	
DOCUMENT NOT CONSIDERED FINAL UNLESS ALL SIGNATURES COMPLETED	

NAD 83/NA 2011

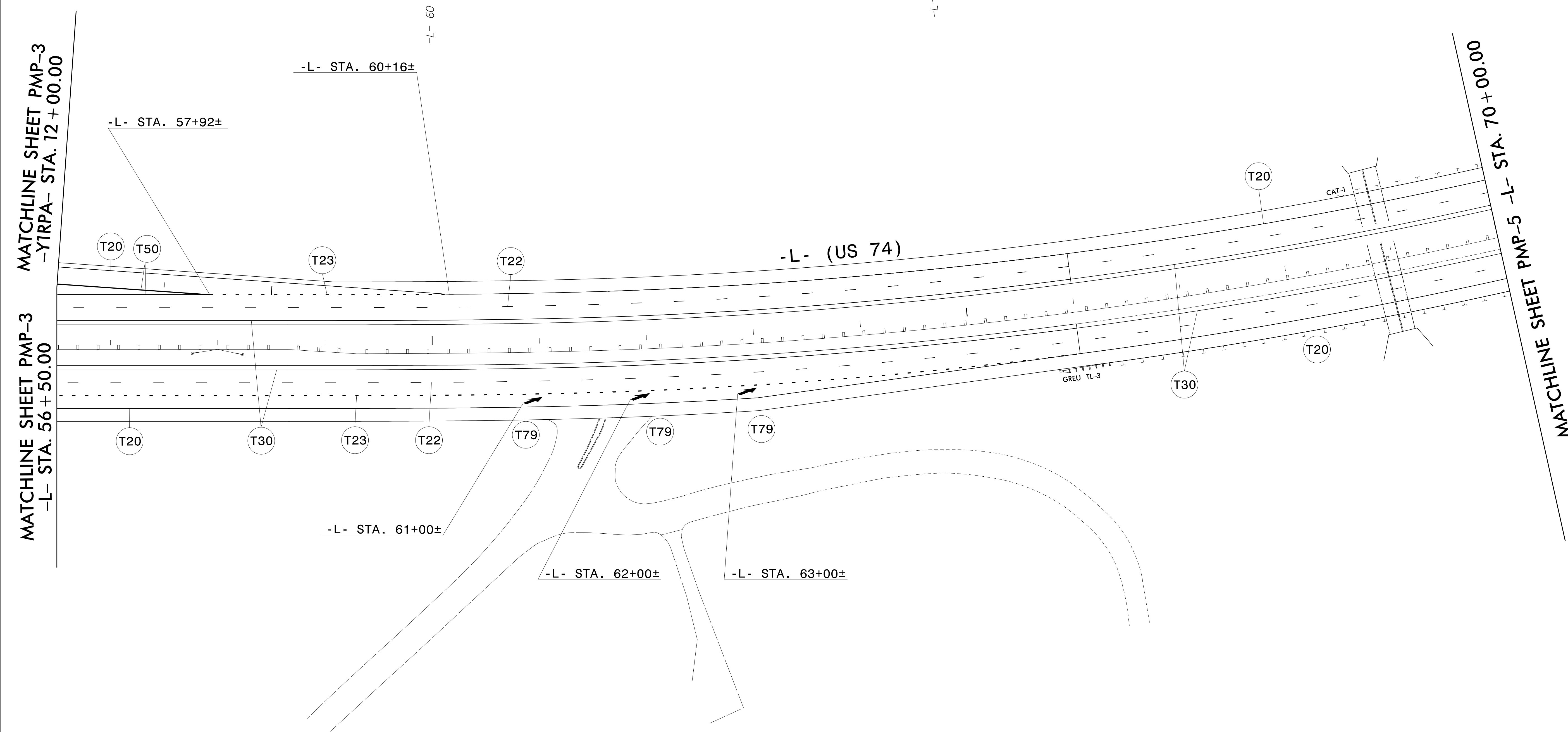

MATCHLINE SHEET PMP-3
-YIRPA- STA. 12+00.00

MATCHLINE SHEET PMP-3
-L- STA. 56+50.00

MATCHLINE SHEET PMP-5 -L- STA. 70+00.00

10/5/2022
R:\Tr\office\Delinect\N-5751\pmp-dtl\04.dgn
User: Bondu

RS&H 8521 SIX FORKS ROAD, SUITE 400
RALEIGH, NC 27615
NC FIRM LICENSE No: F-0493

PAVEMENT MARKING DETAIL

TIP NO. SHEET NO.

R-5751 PMP-5

APPROVED: _____

DATE: _____

SEAL



DOCUMENT NOT CONSIDERED FINAL
UNLESS ALL SIGNATURES COMPLETED

NAD 83/NA 2011

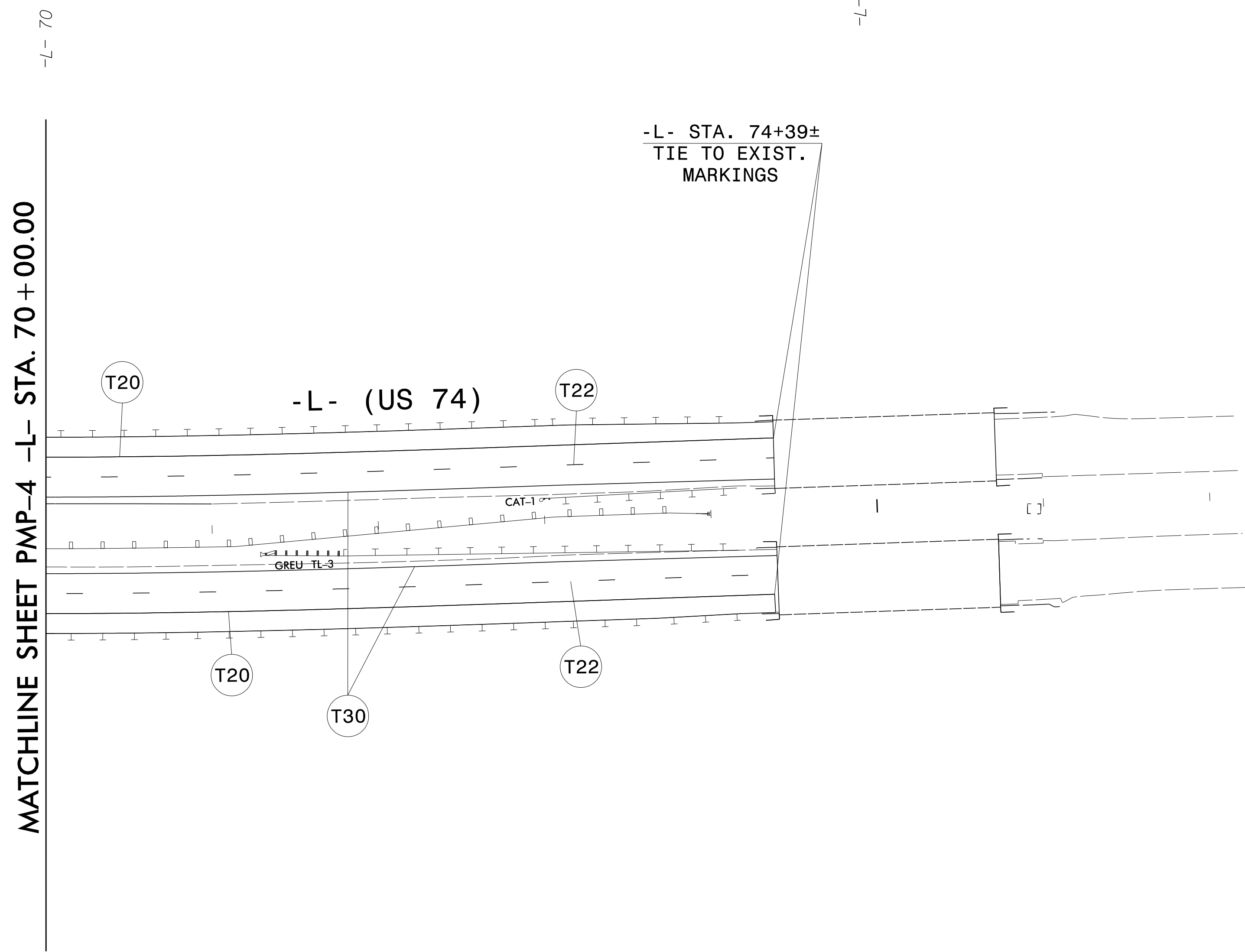

10/5/2022
R:\Tr\office\Delinect\N-5751_pmp-dtl-05.dgn
User:Bondu

RS&H 8521 SIX FORKS ROAD, SUITE 400
RALEIGH, NC 27615
NC FIRM LICENSE No: F-0493

PAVEMENT MARKING DETAIL

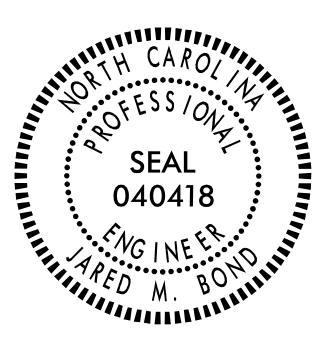
TIP NO. R-5751	SHEET NO. PMP-6
APPROVED: _____	
DATE: _____	
SEAL	
	
DOCUMENT NOT CONSIDERED FINAL UNLESS ALL SIGNATURES COMPLETED	

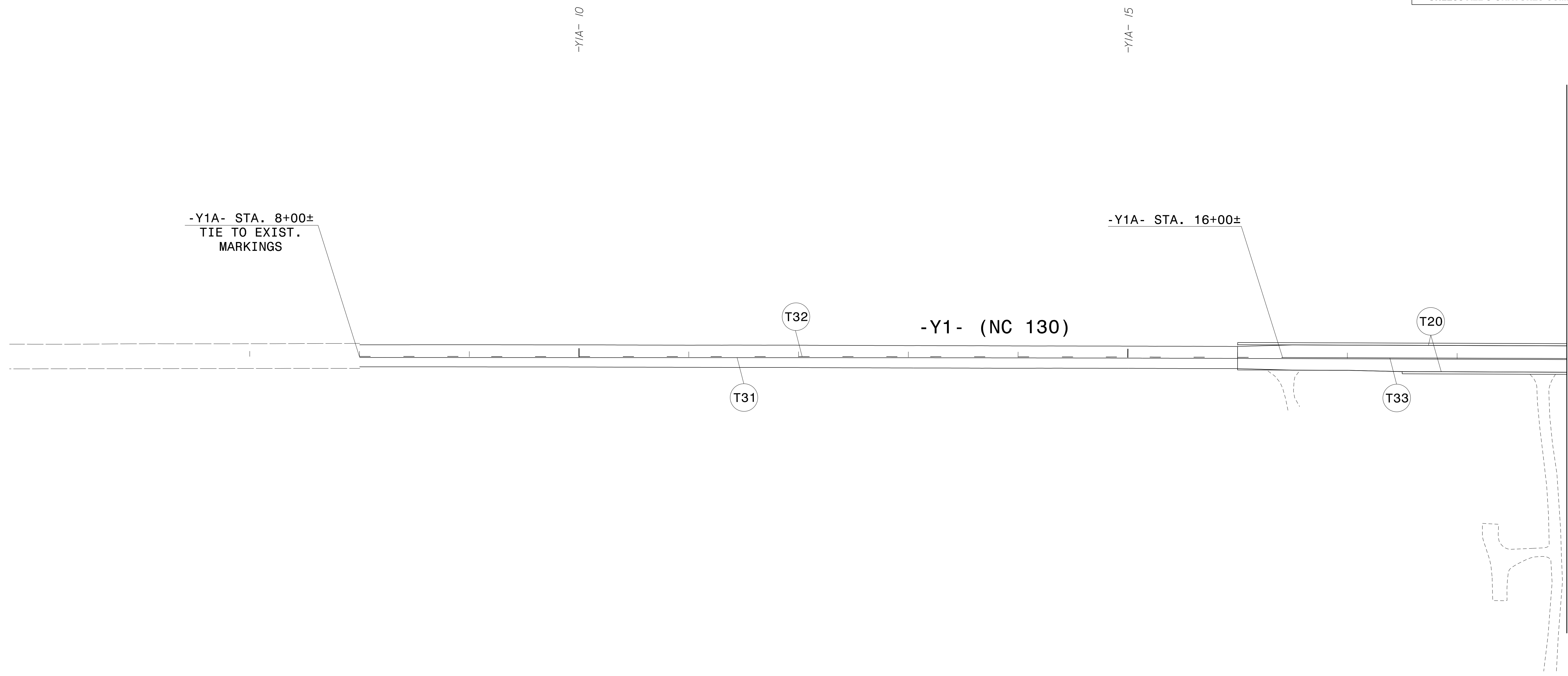
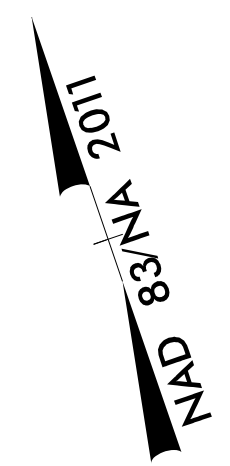

10/5/2022
 R:\Tr\office\Delinect\N-R-5751.pmp.dtl.06.dgn
 User:Bondu

RS&H
 8521 SIX FORKS ROAD, SUITE 400
 RALEIGH, NC 27615
 NC FIRM LICENSE No: F-0493

PAVEMENT MARKING DETAIL

TIP NO. R-5751	SHEET NO. PMP-7
APPROVED: _____	
DATE: _____	
SEAL	
	
DOCUMENT NOT CONSIDERED FINAL UNLESS ALL SIGNATURES COMPLETED	

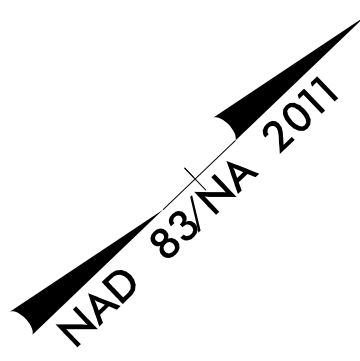

MATCHLINE SHEET PMP-6 -Y1A- STA. 19+00.00

MATCHLINE SHEET PMP-3 -Y1A- STA. 31+00.00

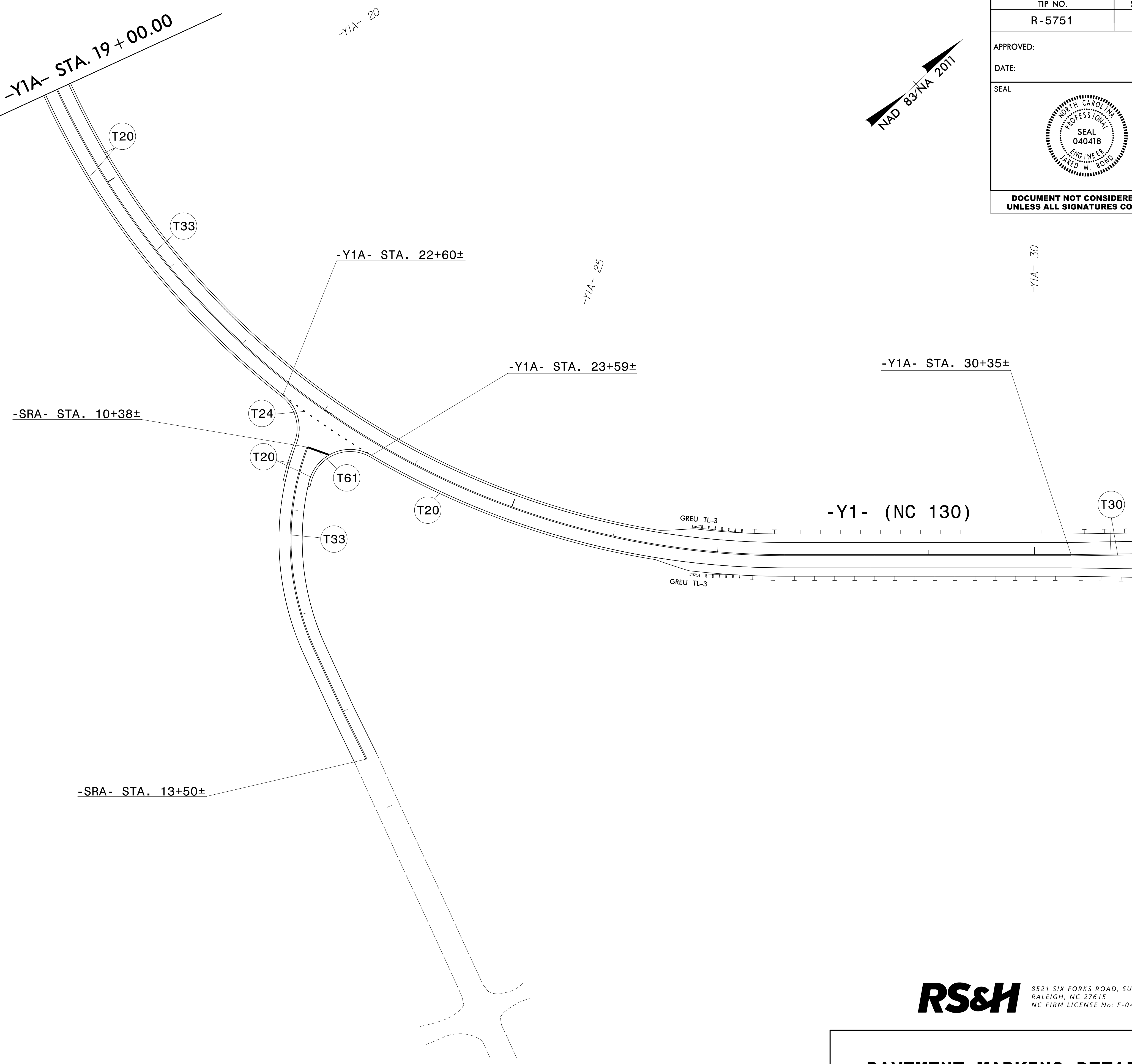

RS&H 8521 SIX FORKS ROAD, SUITE 400
RALEIGH, NC 27615
NC FIRM LICENSE No: F-0493

PAVEMENT MARKING DETAIL

10/5/2022
 R:\Tr\office\Delinect\ion\R-5751.pmp.dtl.07.dgn
 User: Bondu

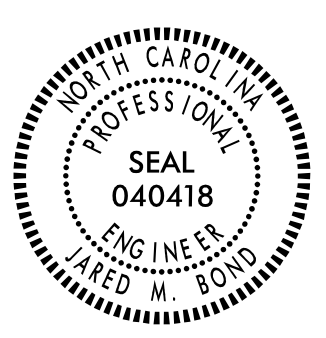
TIP NO. R-5751	SHEET NO. PMP-8
APPROVED: _____	
DATE: _____	
SEAL	
	
DOCUMENT NOT CONSIDERED FINAL UNLESS ALL SIGNATURES COMPLETED	

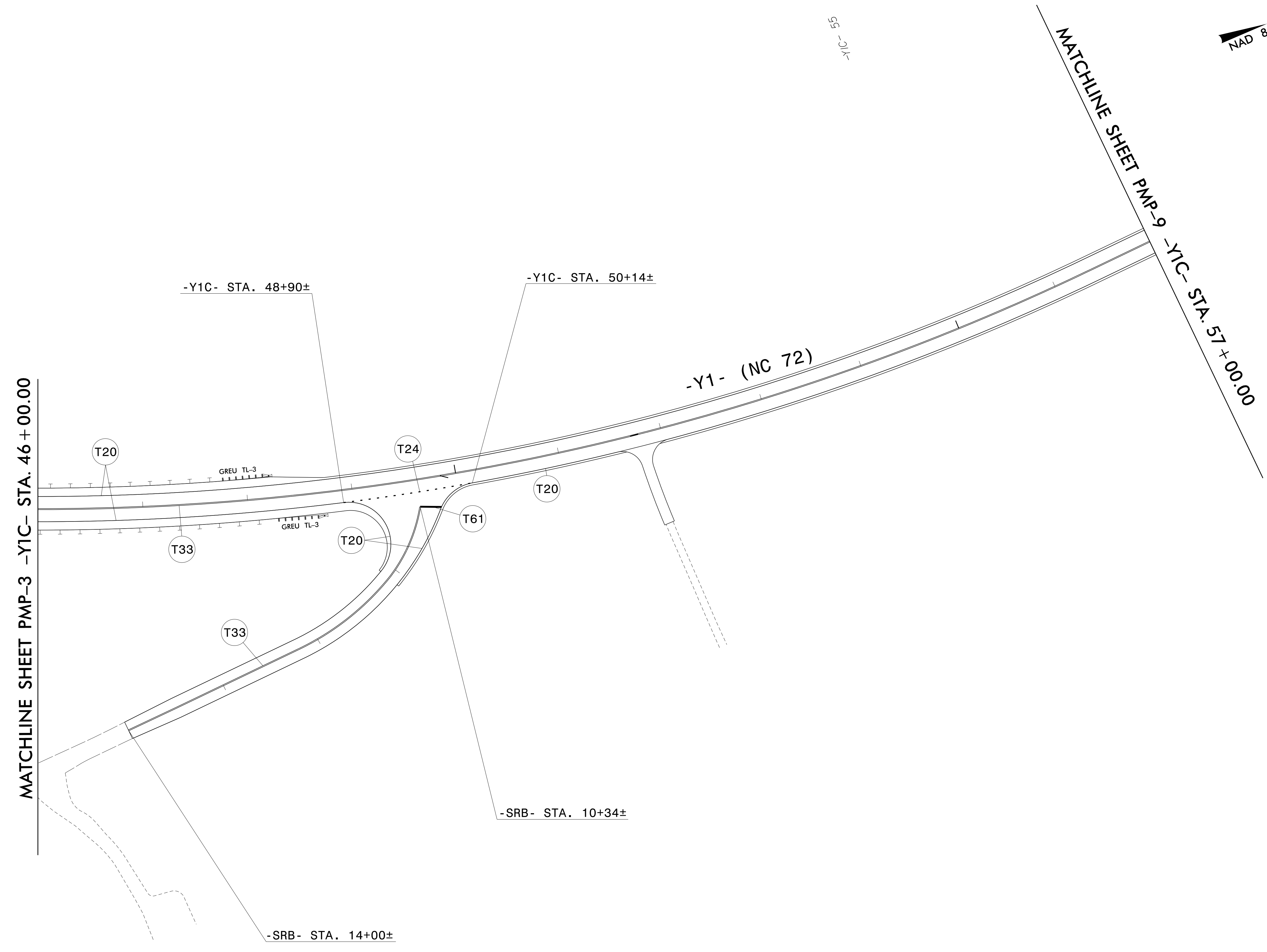
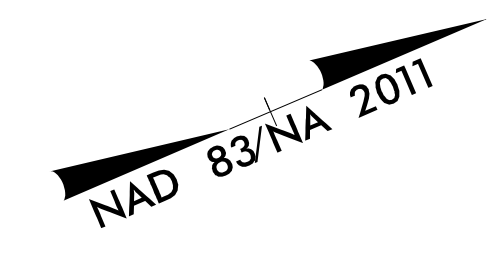

10/5/2022
 R:\Tr\office\Delinect\N-5751.pmp-dtL08.dgn
 User:Bondu

RS&H
 8521 SIX FORKS ROAD, SUITE 400
 RALEIGH, NC 27615
 NC FIRM LICENSE No: F-0493

PAVEMENT MARKING DETAIL

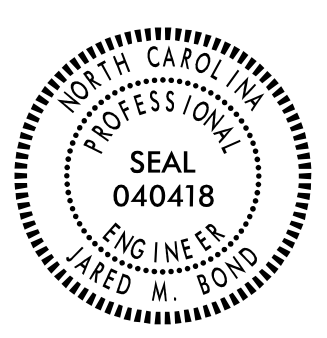
TIP NO.	SHEET NO.
R-5751	PMP-9
APPROVED: _____	
DATE: _____	
SEAL	
	
DOCUMENT NOT CONSIDERED FINAL UNLESS ALL SIGNATURES COMPLETED	



MATCHLINE SHEET PMP-8 -Y1C- STA. 57 + 00.00

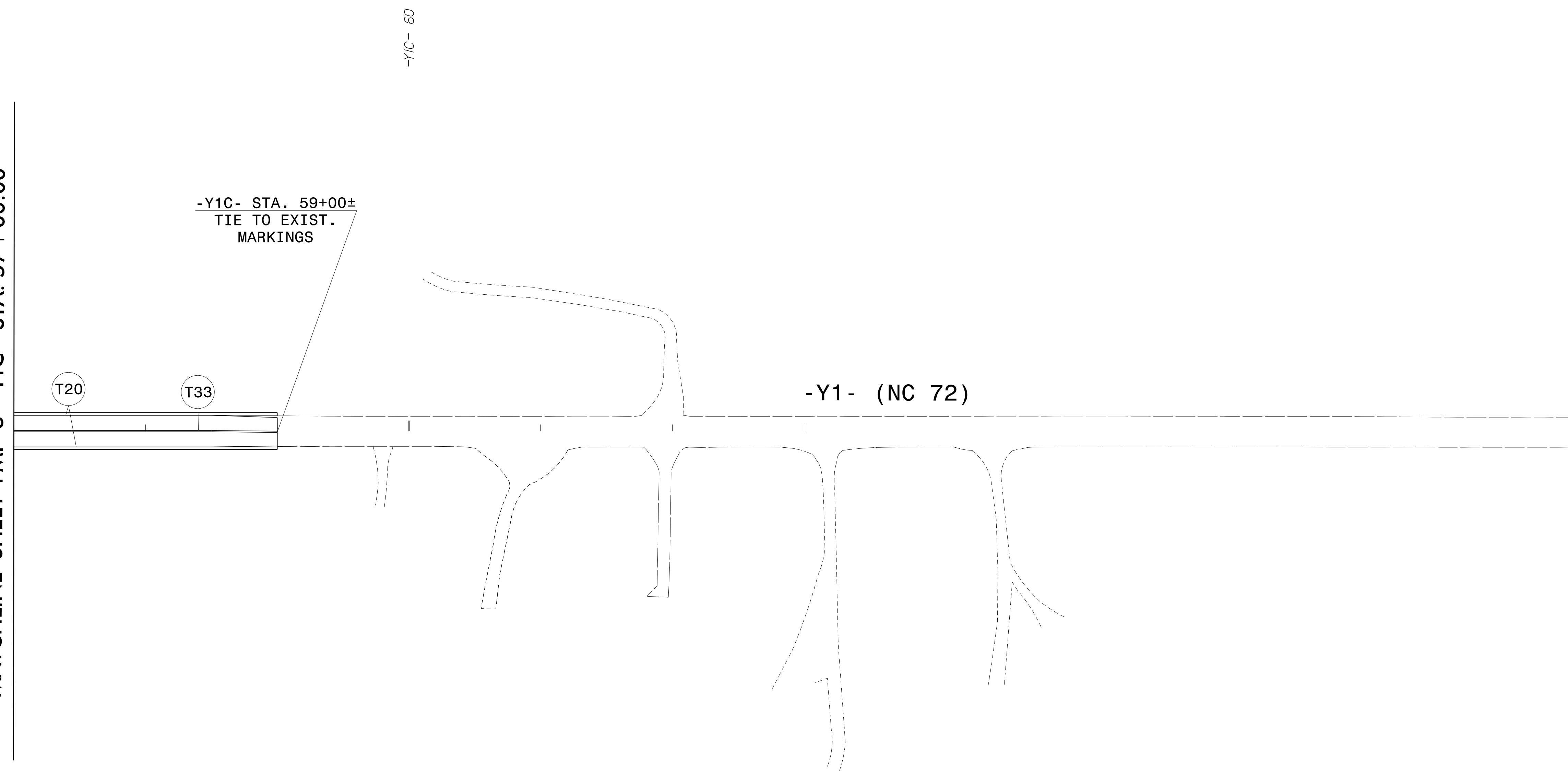

10/5/2022
R:\Tr\office\Delinect\N-5751.pmp.dtl.09.dgn
User: Bondu

RS&H 8521 SIX FORKS ROAD, SUITE 400
RALEIGH, NC 27615
NC FIRM LICENSE No: F-0493

PAVEMENT MARKING DETAIL