

TIP NO. SHEET NO.

R-5751 PMP-5

APPROVED: *Jared M. Bond*  
DocuSigned by:  
E7F10591C74F469...

DATE:

SEAL



**DOCUMENT NOT CONSIDERED FINAL  
UNLESS ALL SIGNATURES COMPLETED**

**NAD 83/NA 2011**

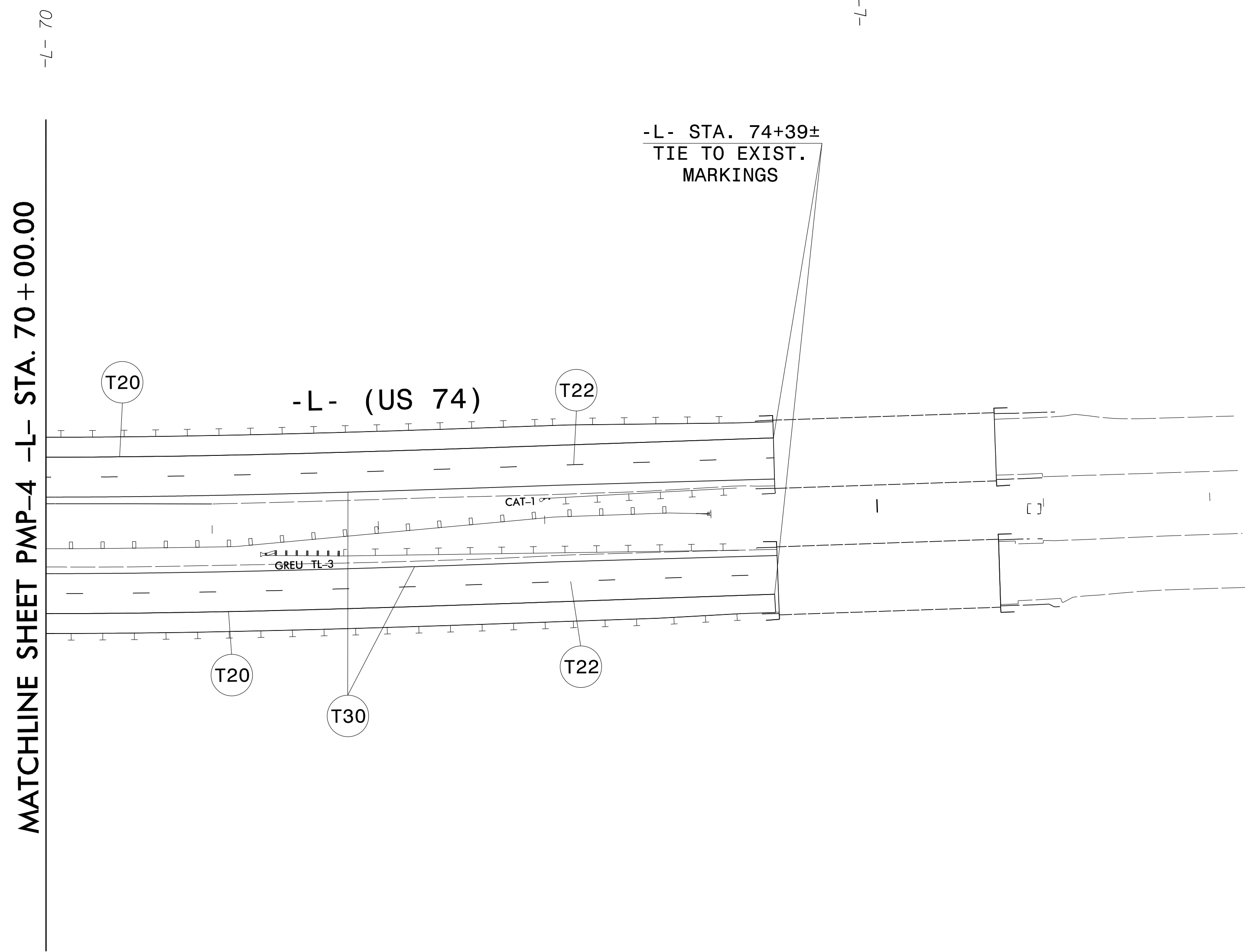

10/5/2022  
R:\Tr\office\Delinect\N-5751.pmp-dtL05.dgn  
User: BondJ

**RS&H** 8521 SIX FORKS ROAD, SUITE 400  
RALEIGH, NC 27615  
NC FIRM LICENSE No: F-0493

**PAVEMENT MARKING DETAIL**