

PROJ. REFERENCE NO.	SHEET NO.	TOTAL SHEETS
IREDELL COUNTY	7	
STATE PROJ. NO.	F.A. PROJ. NO.	DESCRIPTION
2023CPT. 12.05.10491		PRIMARY RESURFACING
2023CPT. 12.05.20491		SECONDARY RESURFACING

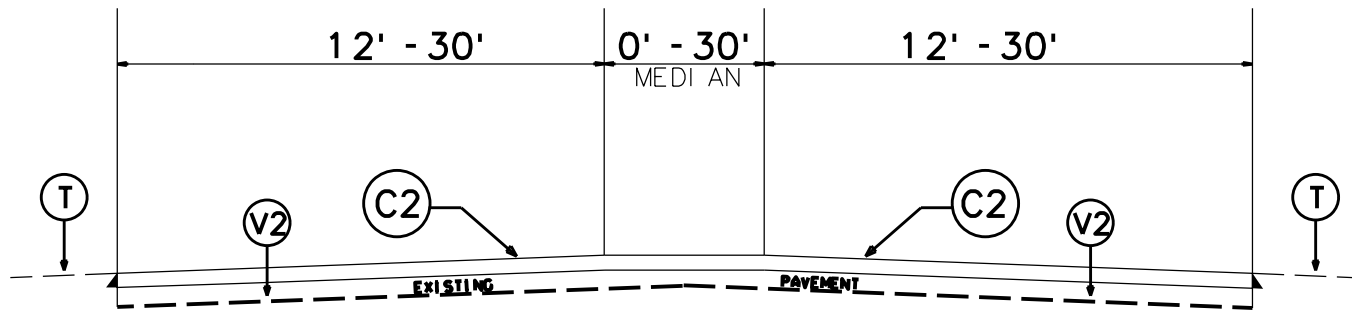

TYPICAL SECTION NO. 1
Maps: 1 (ALL)

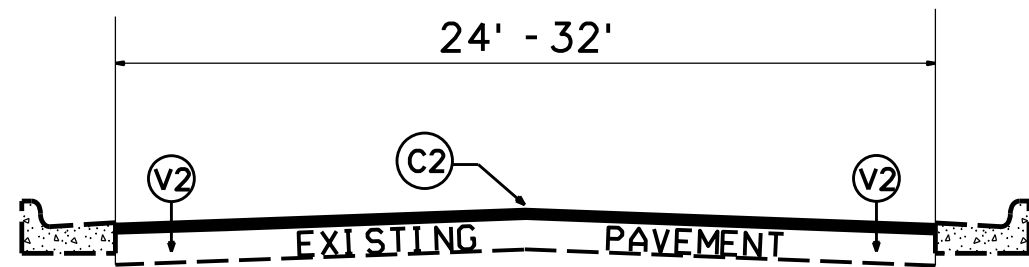

TYPICAL SECTION NO. 2
Maps: 24, 25, 26, 43 (ALL)

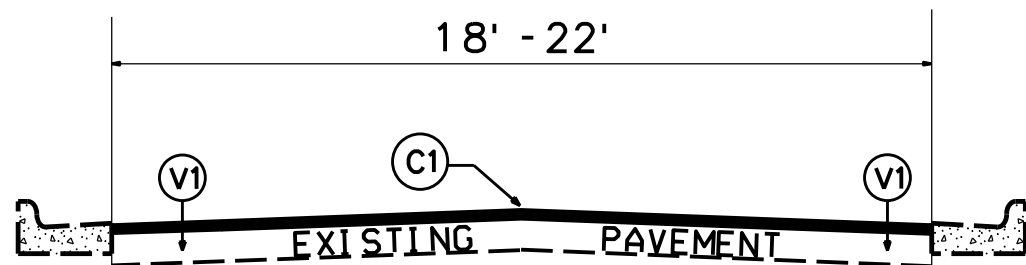

TYPICAL SECTION NO. 3
Maps: 7, 18, 19, 20, 21, 22, 23, 27, 28, 29, 30, 31, 32, 33, 34, 35, 36, 37, 38, 39 (ALL)

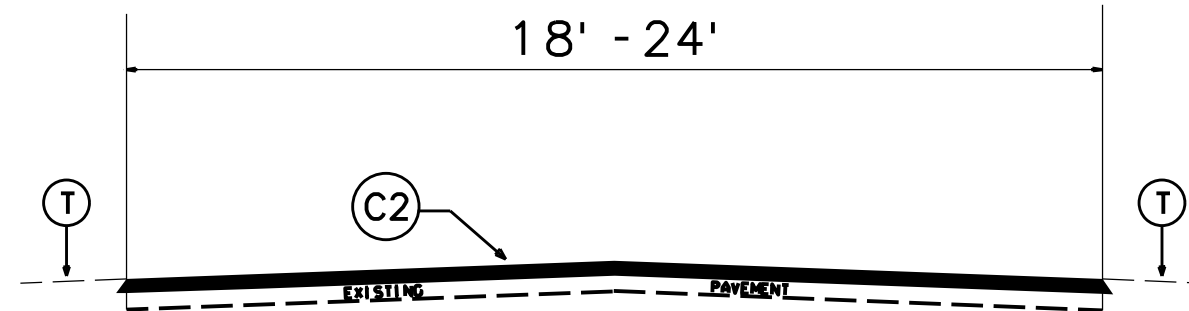

TYPICAL SECTION NO. 4
Maps: 5, 10, 11, 12, 13, 15, 40, 41, 42 (ALL)

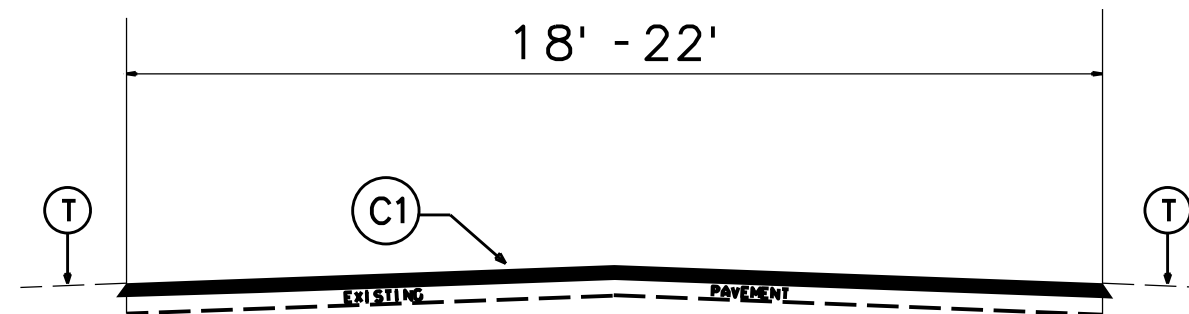

TYPICAL SECTION NO. 5
Maps: 2, 3, 4, 6, 8, 9, 14, 16, 17, 44, 45, 46 (ALL)

PAVEMENT SCHEDULE	
C1	PROP. APPROX. 1.0" ASPHALT CONCRETE SURFACE COURSE, TYPE S9.5B, AT AN AVERAGE RATE OF 110 LBS. PER SQ. YD.
C2	PROP. APPROX. 1.5" ASPHALT CONCRETE SURFACE COURSE, TYPE S9.5C, AT AN AVERAGE RATE OF 168 LBS. PER SQ. YD.
T	AGGREGATE SHOULDER BORROW (SHOULDER RECONSTRUCTION)
V1	MILL EXISTING ASPHALT PAVEMENT APPROX. 1" IN DEPTH
V2	MILL EXISTING ASPHALT PAVEMENT APPROX. 1.5" IN DEPTH

2023-2024
Resurfacing Program
Typical Sections
Iredell County

PROJ. REFERENCE NO.	SHEET NO.	TOTAL SHEETS
IREDELL COUNTY	8	
STATE PROJ. NO.	F.A. PROJ. NO.	DESCRIPTION
2023CPT. 12. 05. 10491		PRIMARY RESURFACING
2023CPT. 12. 05. 20491		SECONDARY RESURFACING

DETAIL A
PATCHING EXISTING PAVEMENT

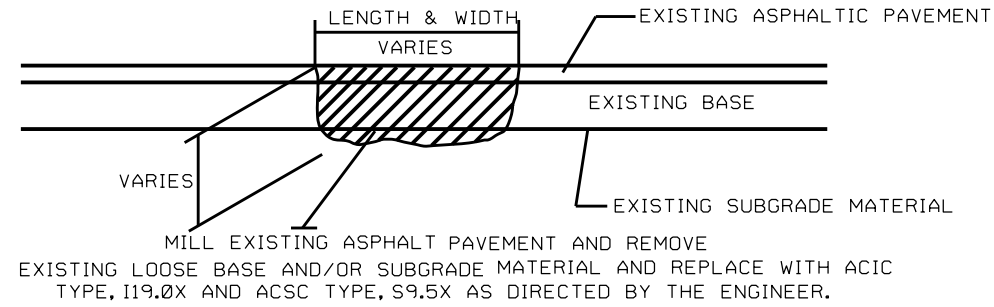

DETAIL C
MILLING BRIDGE APPROACHES



(Maps 5, 8, 10, 11, 14, 40, 44)

DETAIL B

ASPHALT CONCRETE SURFACE COURSE
TYPE S9.5B & S9.5C (LEVELING COURSE)

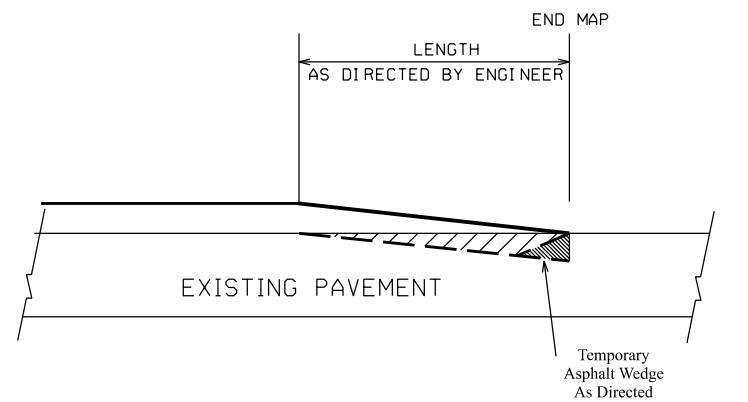
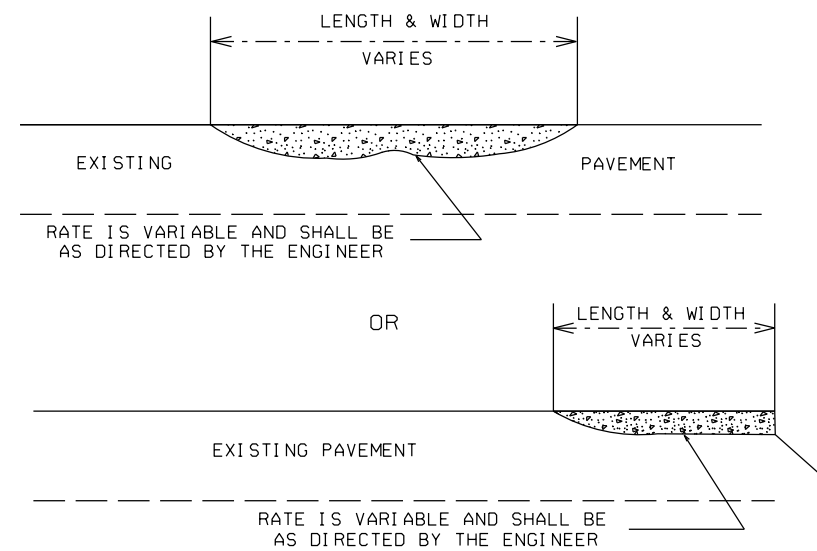

TIE-IN (INCIDENTAL) MILLING DETAIL

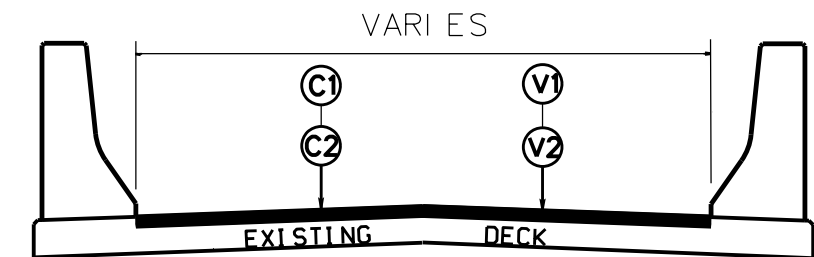

ASPHALT BRIDGE SECTION
Use for all asphalt bridges

DETAIL E

BRIDGE HALF TYPICAL SECTION

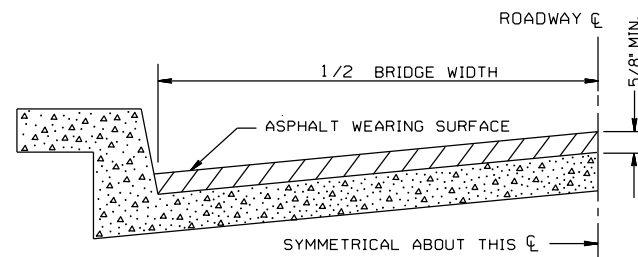

FOR BRIDGES WITH FLOOR DRAINS, CARE SHALL BE EXERCISED IN PLACING THE WEARING SURFACE AROUND FLOOR DRAINS SO AS NOT TO HINDER EFFECTIVE DRAINAGE. ALL DRAINS SHALL BE LEFT OPEN.

THE PROPOSED WEARING SURFACE SHALL VARY IN THICKNESS AS NECESSARY TO PROVIDE A SMOOTH RIDING SURFACE. A THICKNESS OF NOT LESS THAN 5/8" SHALL BE PROVIDED. THE MAXIMUM THICKNESS SHALL PREFERABLY BE 1-1/2" UNLESS IT IS IMPRACTICAL TO PROVIDE A SMOOTH RIDING SURFACE OTHERWISE.

NOTES

ALL UNPAVED S.R. ROADS TO BE SURFACED 50' FROM EDGE OF PAVEMENT OF MAIN PROJECT.
ALL PAVED S.R. ROADS TO BE RESURFACED TO THE ENDS OF THE RADII, OR AS DIRECTED BY THE ENGINEER.
EDGES, PAVEMENT WIDENING, INTERSECTIONS AND BRIDGE FLARES ARE INCLUDED IN THE TABLE OF QUANTITIES.
SHOULDERS AND DITCHES ARE TO BE CONSTRUCTED BY OTHERS UNLESS OTHERWISE NOTED.
BRIDGES TO BE RESURFACED AT LOCATIONS AND TO DEPTH AS DIRECTED BY THE ENGINEER.

PAVEMENT SCHEDULE

C1	PROP. APPROX. 1.0" ASPHALT CONCRETE SURFACE COURSE, TYPE S9.5B, AT AN AVERAGE RATE OF 110 LBS. PER SQ. YD.
C2	PROP. APPROX. 1.5" ASPHALT CONCRETE SURFACE COURSE, TYPE S9.5C, AT AN AVERAGE RATE OF 168 LBS. PER SQ. YD.
T	AGGREGATE SHOULDER BORROW (SHOULDER RECONSTRUCTION)
V1	MILL EXISTING ASPHALT PAVEMENT APPROX. 1" IN DEPTH
V2	MILL EXISTING ASPHALT PAVEMENT APPROX. 1.5" IN DEPTH

2023 - 2024
Resurfacing Program
Typical Sections
Iredell County

NOTES:

- 1) DETAIL DOES NOT APPLY TO OGAFB AND ULTRA-THIN BONDED WEARING COURSE.
- 2) BACKFILL SHOULDER WITH APPROVED MATERIAL.
- 3) THE SHOULDER WEDGE DEVICE MAY BE DISENGAGED AT PAVED DRIVEWAYS, SIDE STREETS, HIGH SHOULDERS, AND OTHER LOCATIONS NOT FEASIBLE TO CONSTRUCT AS APPROVED BY THE ENGINEER.

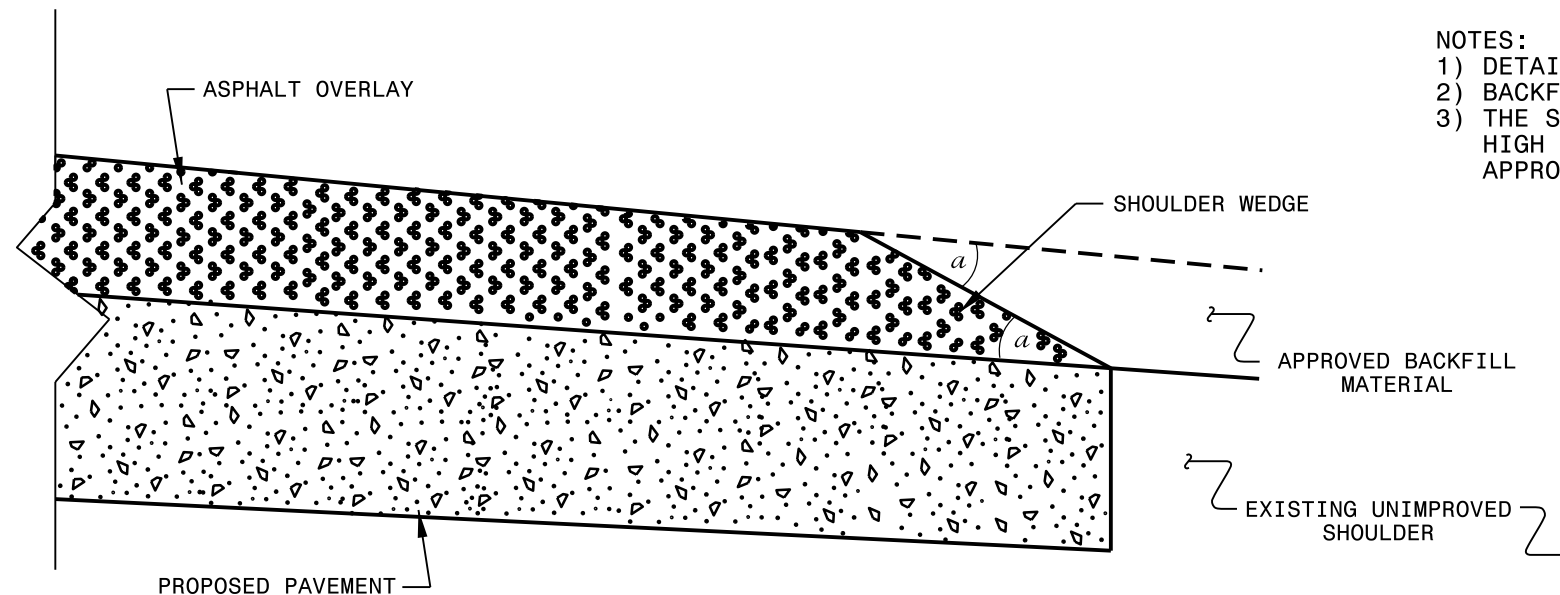

SHOULDER WEDGE DETAIL
 (Resurfacing Projects w/ Widening or
 with Existing Paved Shoulder having no dropoffs)

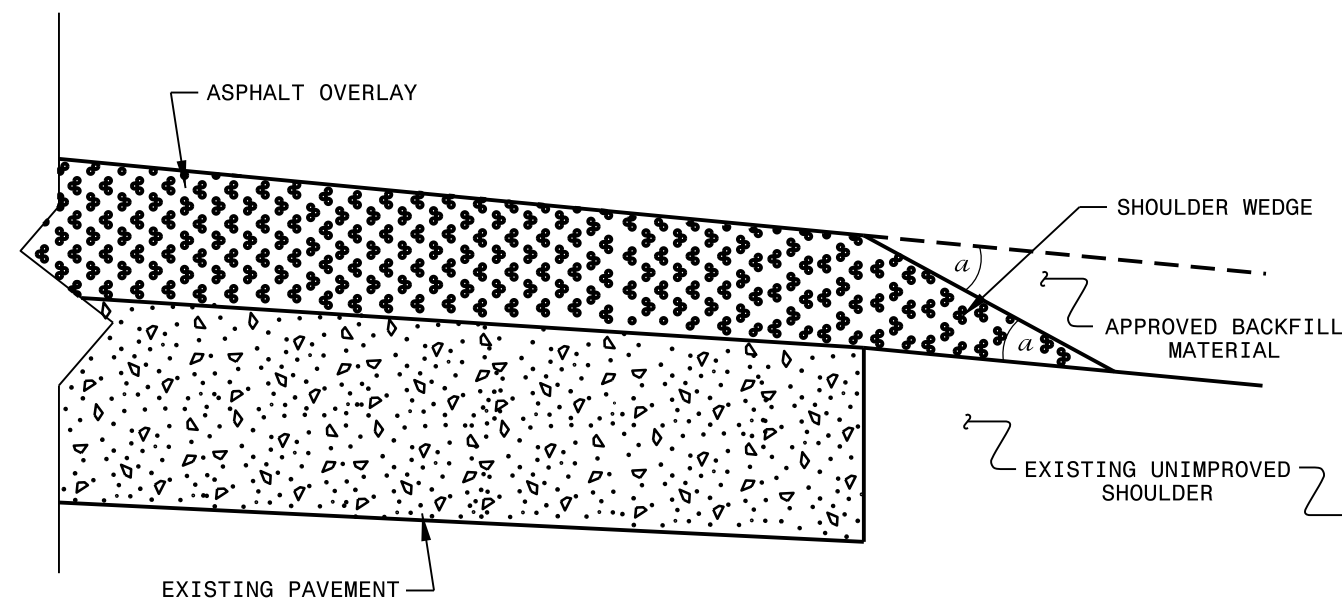

SHOULDER WEDGE DETAIL
 (Resurfacing Projects w/ NO Widening)

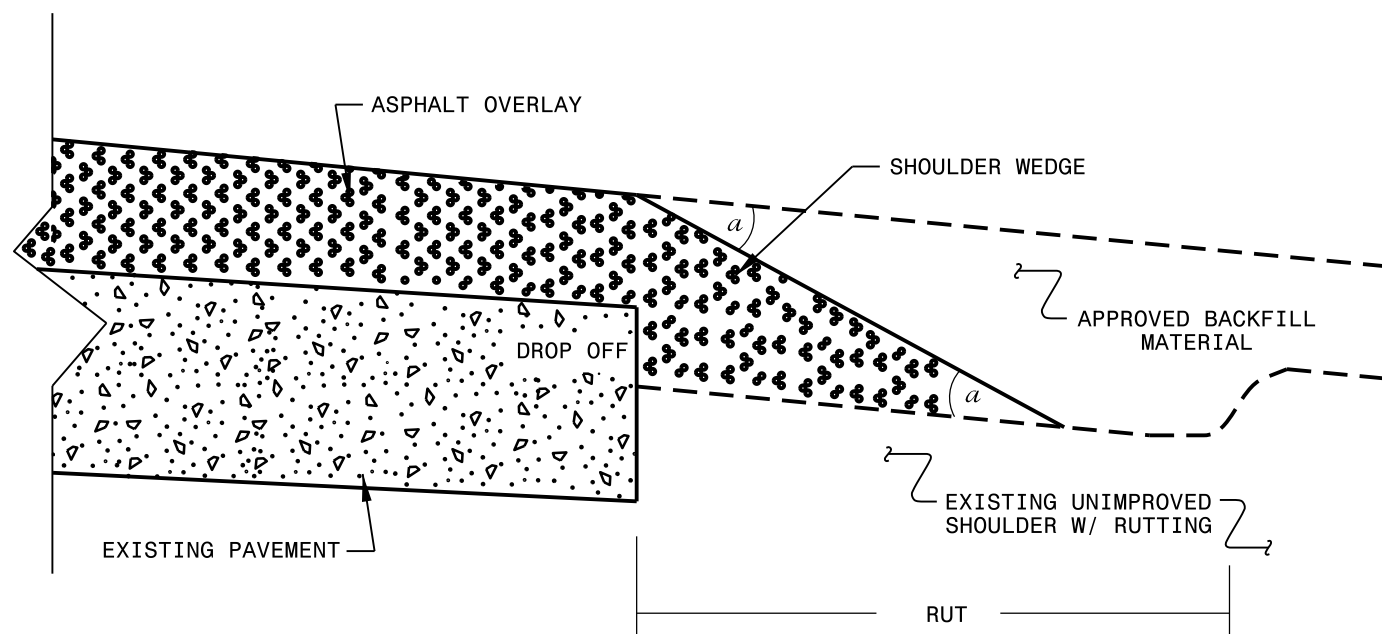

SHOULDER WEDGE DETAIL
 (Resurfacing Adjacent to
 Rutted Shoulder)

- SHOULDER WEDGE ANGLE = 30°

\$\$\$\$SYTIME\$\$\$\$
 \$\$\$USERNAME\$\$\$

CONTRACT STANDARDS AND DEVELOPMENT UNIT	
Office 919-707-6950 FAX 919-250-4119	
SHOULDER WEDGE DETAILS	
ORIGINAL BY: T.SPELL	DATE: 7-19-11
MODIFIED BY:	DATE: 2/2/16
CHECKED BY:	DATE:
FILE SPEC.: s:\usr\det11s\stand\shoulderwedgedeta11.dgn	

DOCUMENT NOT CONSIDERED FINAL
UNLESS ALL SIGNATURES COMPLETED

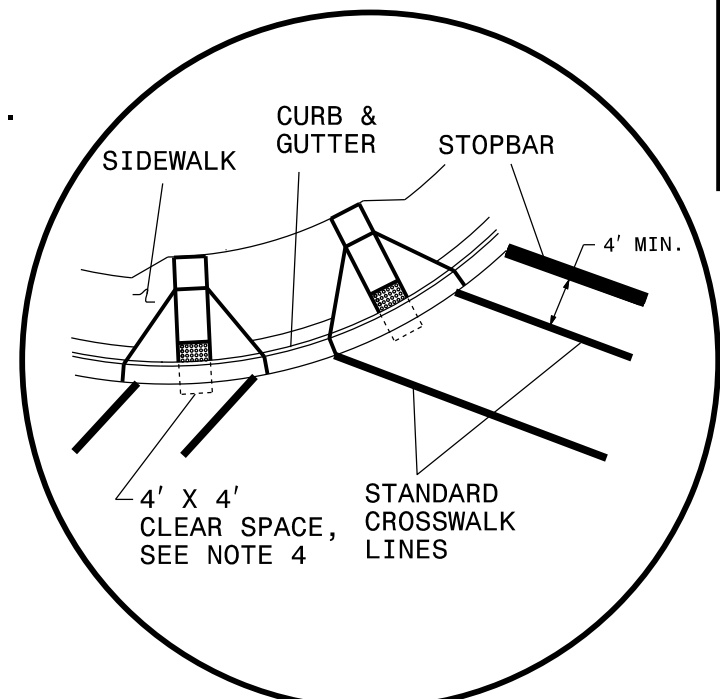
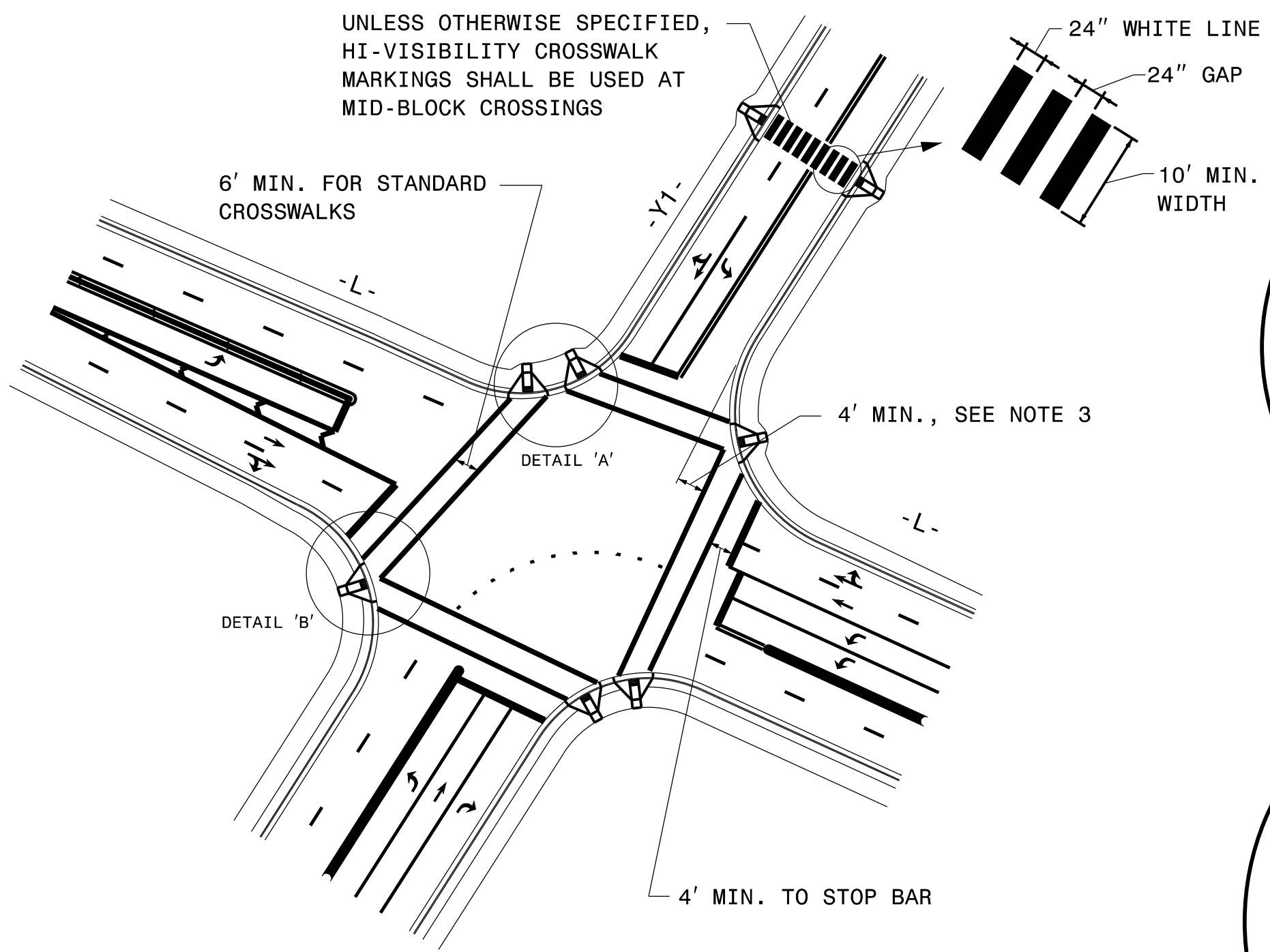

DETAIL 'A'- DUAL CURB RAMPS

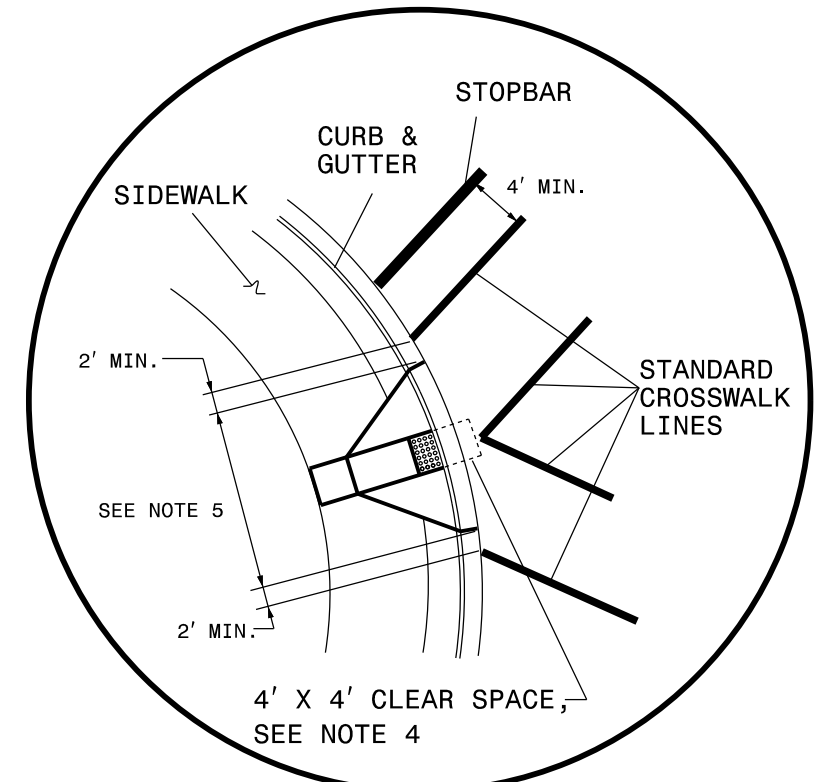

DETAIL 'B'- SINGLE DIAGONAL CURB RAMP

GUIDANCE DETAIL FOR CROSSWALK MARKINGS

NOTES:

1. USE THE DETAILS ABOVE AND THE FOLLOWING NOTES FOR GUIDANCE IN PLACING CROSSWALK MARKINGS NOT STATIONED ON THE DETAIL SHEETS OR WHEN FIELD ADJUSTMENTS REQUIRED MOVING STATIONED MARKINGS AS DIRECTED BY THE ENGINEER. REFER TO NCDOT ROADWAY STANDARD DRAWINGS, MUTCD AND ADA STANDARDS FOR ADDITIONAL GUIDANCE.
2. THE CROSSWALK MARKINGS SHOWN ON THE ABOVE DETAILS ARE FOR REFERENCE ONLY. ONLY INSTALL CROSSWALK MARKINGS WHERE SHOWN ON THE DETAIL SHEETS OR AS DIRECTED BY THE ENGINEER. THE CROSSWALK MARKING TYPE, STANDARD OR HI-VISIBILITY, SHALL BE INSTALL AS SPECIFIED ON THE DETAIL SHEETS OR AS DIRECTED BY THE ENGINEER.
3. SET BACK DISTANCE FROM INSIDE CROSSWALK MARKING TO NEAREST EDGE OF TRAVEL IS 4' MIN.
4. BEYOND THE BOTTOM GRADE BRAKE, A CLEAR SPACE OF 4' X 4' MINIMUM SHALL BE PROVIDED WITHIN THE MARKINGS.
5. SINGLE DIAGONAL CURB RAMPS WITH FLARED SIDES SHALL HAVE A SEGMENT OF CURB 2 FEET LONG MINIMUM LOCATED ON EACH SIDE OF THE CURB RAMP AND WITHIN THE MARKED CROSSING, SEE DETAIL 'B'.
6. CURB RAMPS SHALL BE CONSTRUCTED IN ACCORDANCE TO THE LATEST NCDOT ROADWAY STANDARD DRAWINGS.

\$\$\$\$\$SYTIME\$\$\$\$\$
 \$\$\$DCON\$\$\$\$\$
 \$\$\$USERNAME\$\$\$\$\$

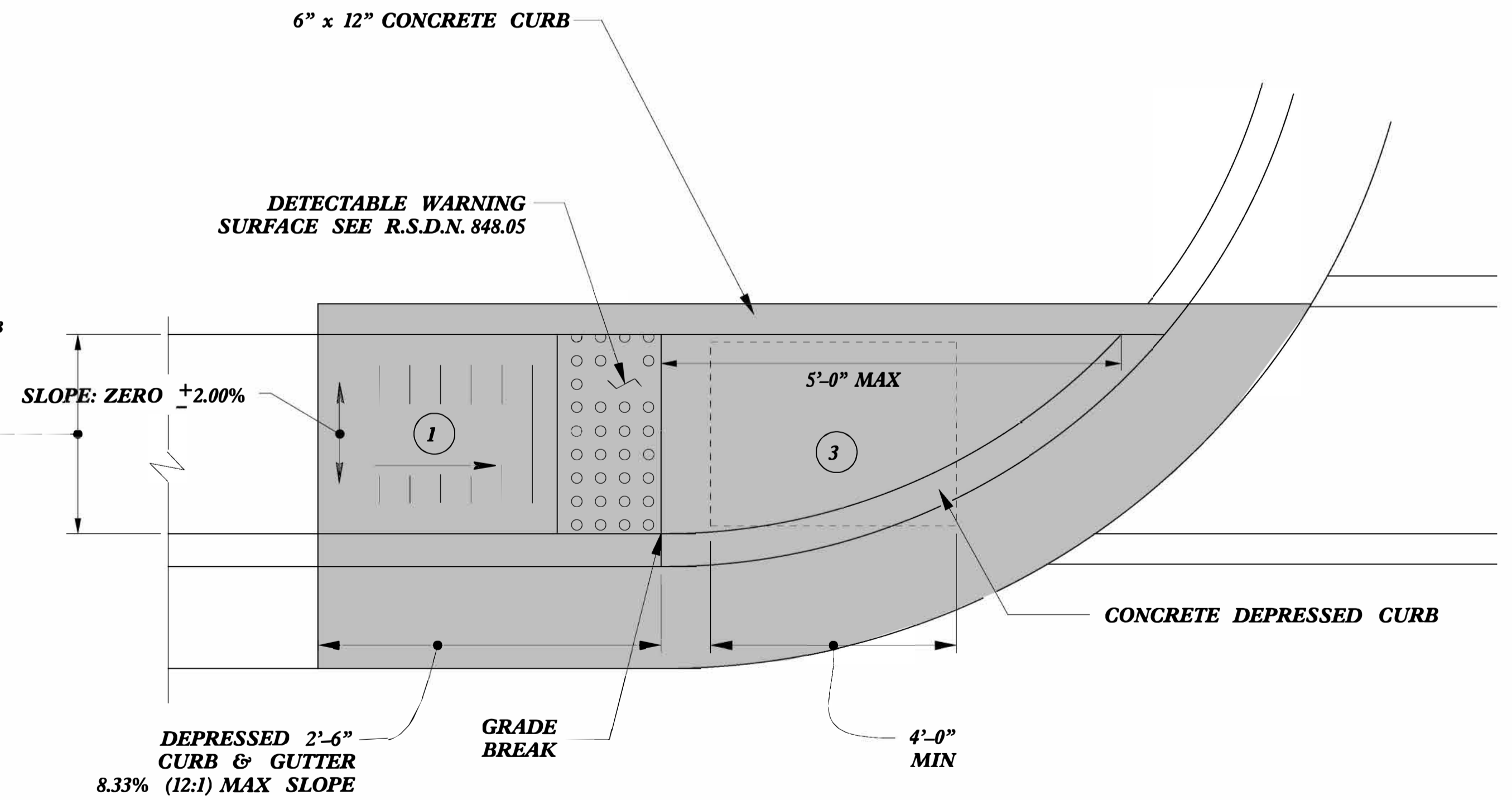
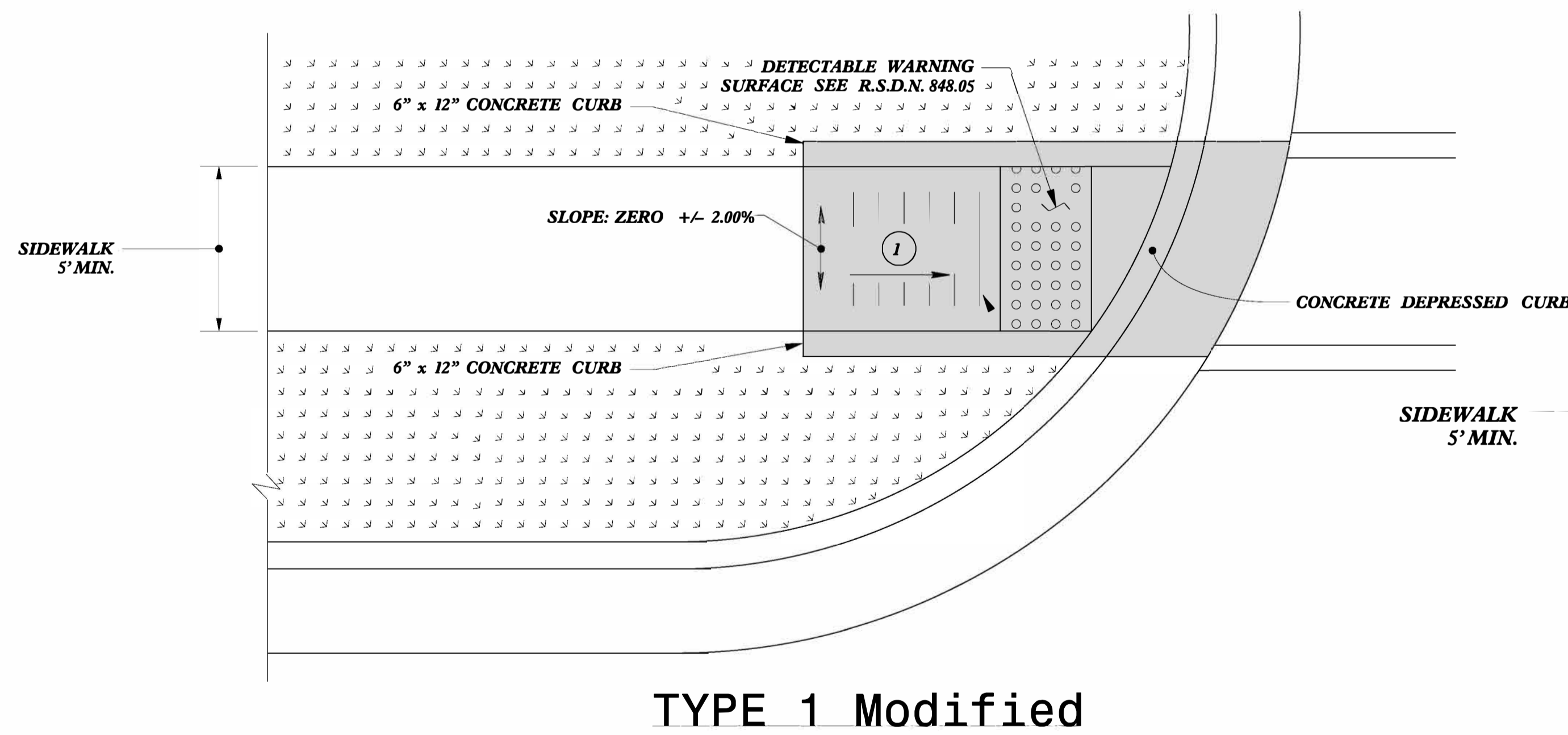
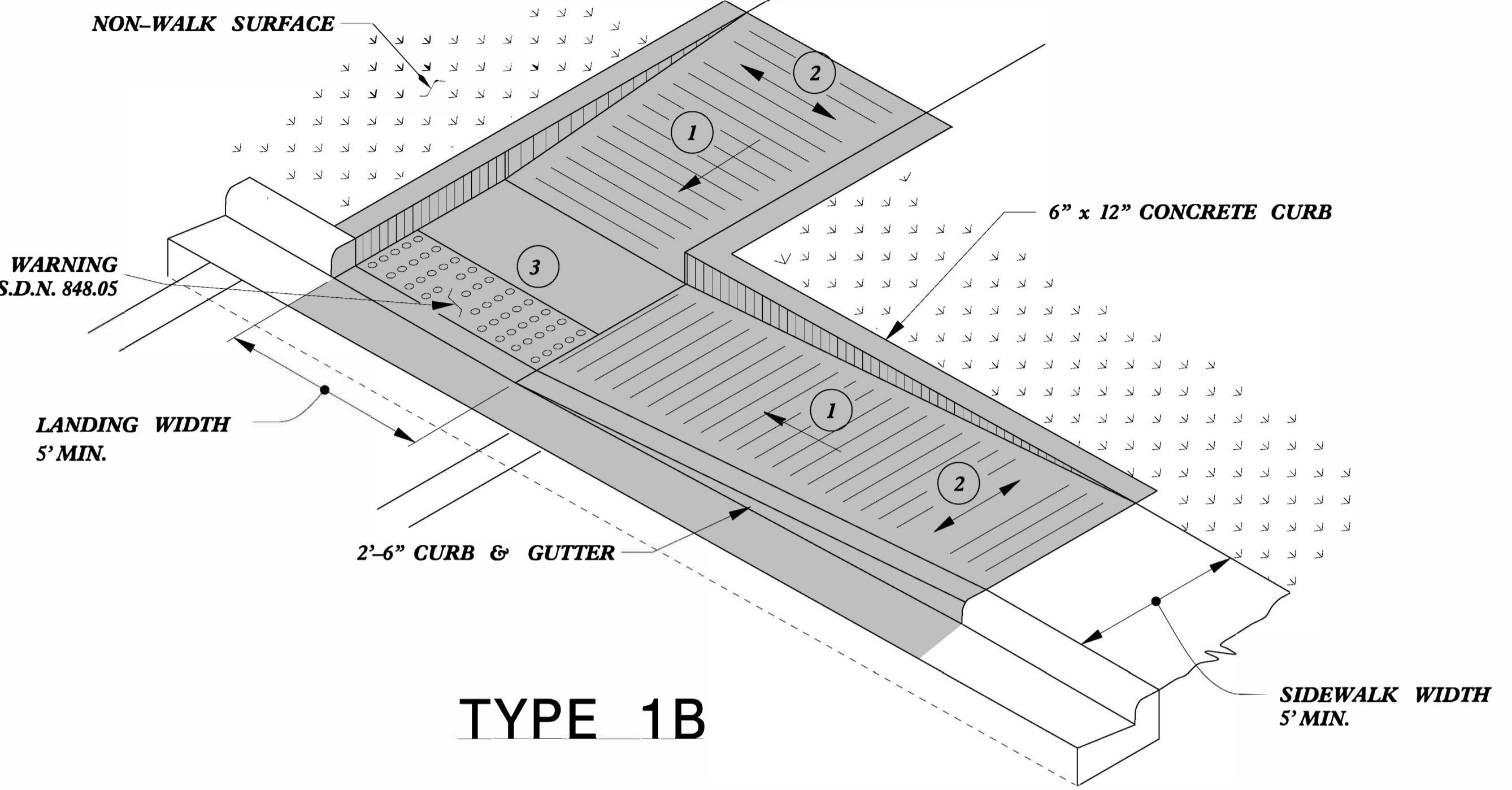
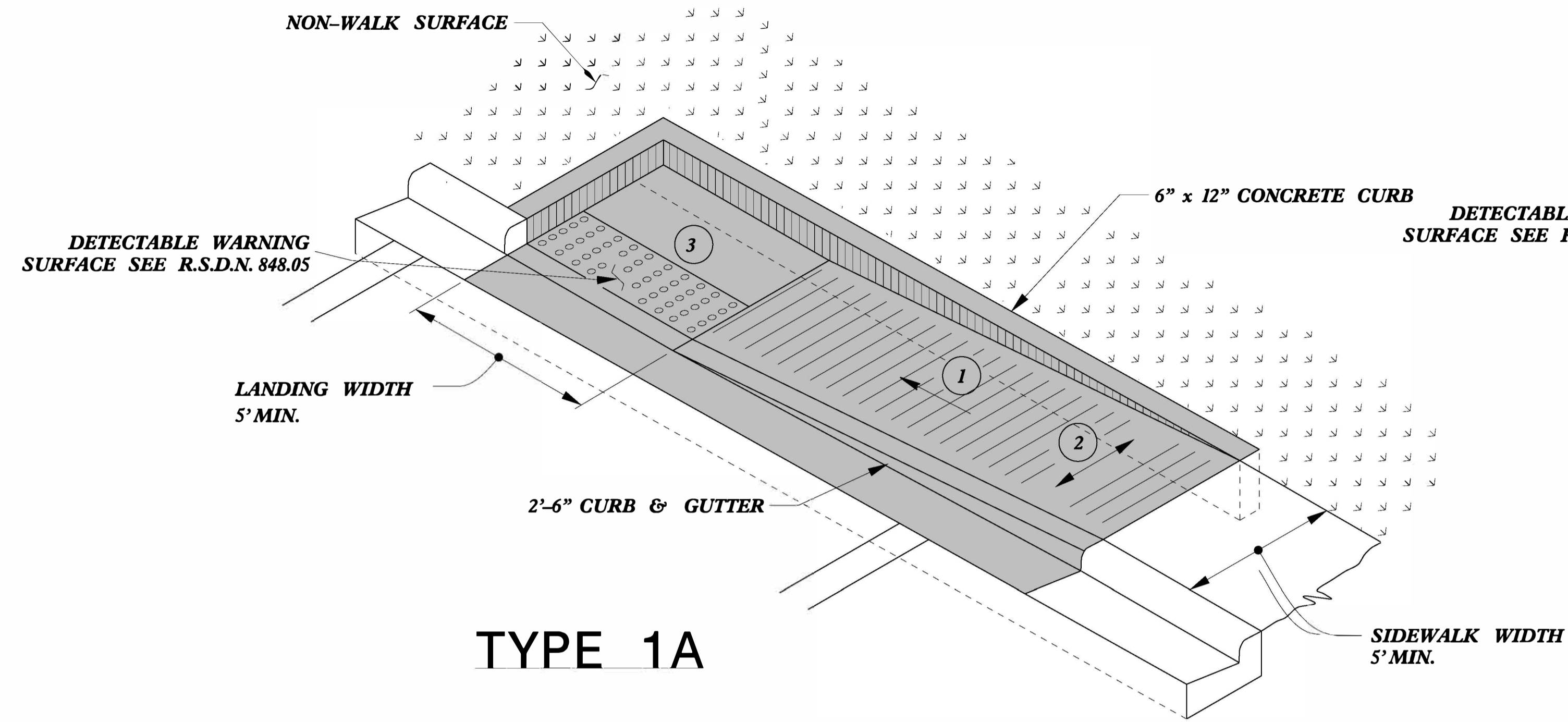

- 1 8.33% (12:1) MAX RAMP SLOPE
- 2 CROSS SLOPE: 2.00%
- 3 CURB RAMPS REQUIRE A (4'-0") MINIMUM LANDING WITH A MAXIMUM CROSS SLOPE AND LONGITUDINAL SLOPE OF 2.00% WHERE PEDESTRIANS PERFORM TURNING MANEUVERS. SLOPE TO DRAIN TO CURB.

PAY LIMITS FOR 1 CURB RAMP

REFER TO ROADWAY STANDARD DRAWING NUMBER 848.05 SHEET 3 OF 3 FOR ALL RAMP NOTES

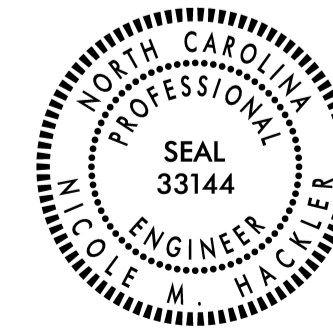

DOCUMENT NOT CONSIDERED FINAL UNLESS ALL SIGNATURES COMPLETED

CONTRACT STANDARDS AND DEVELOPMENT UNIT
Office 919-707-6950 FAX 919-250-4119

CURB RAMPS
Directional Ramps

ORIGINAL BY: J.S. HOWERTON DATE: 7/7/11
MODIFIED BY: DATE:
CHECKED BY: DATE:
FILE SPEC: stds/2012CurbRamp/CurbRampDetails.dgn

5/14/99

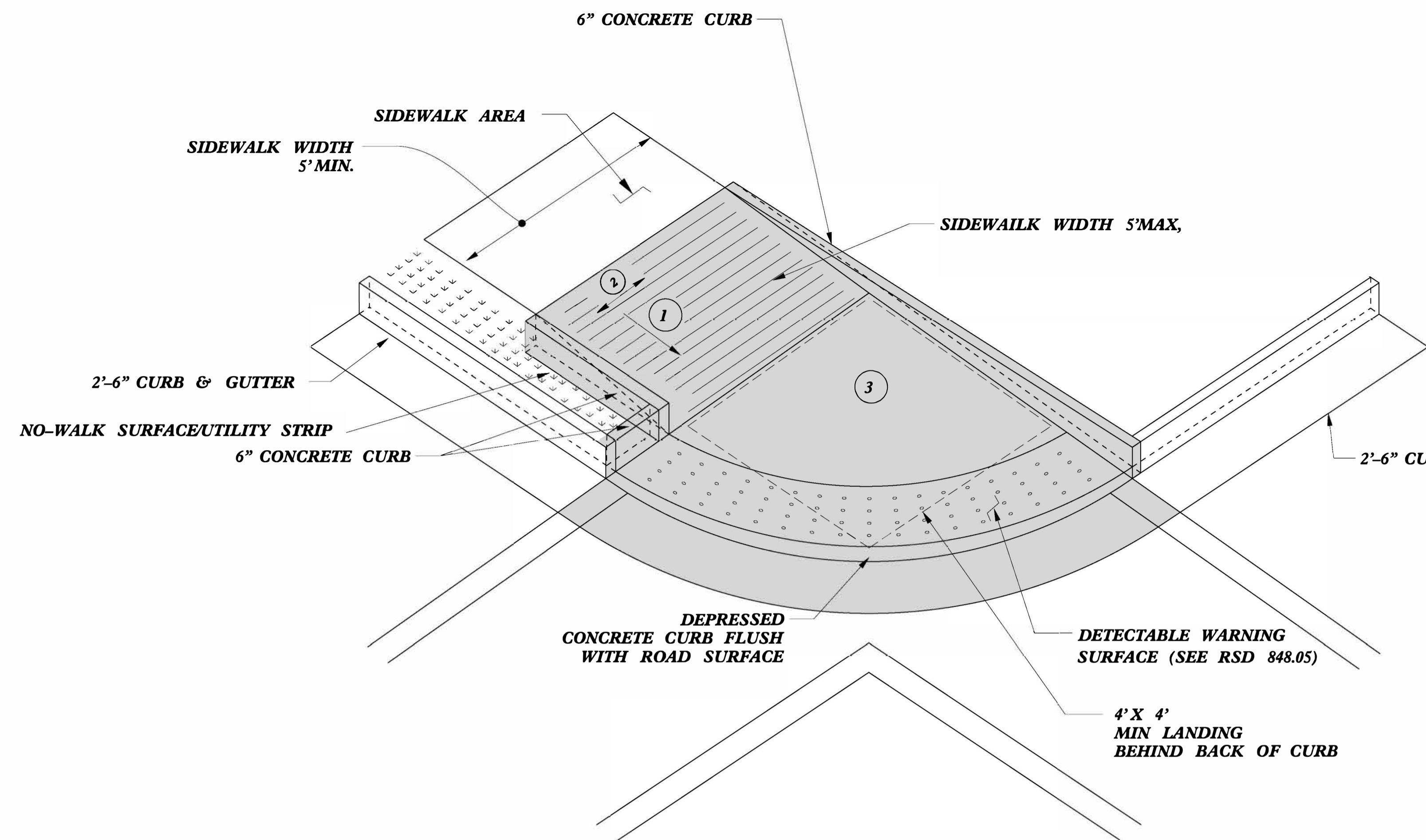

TYPE 2A MOD

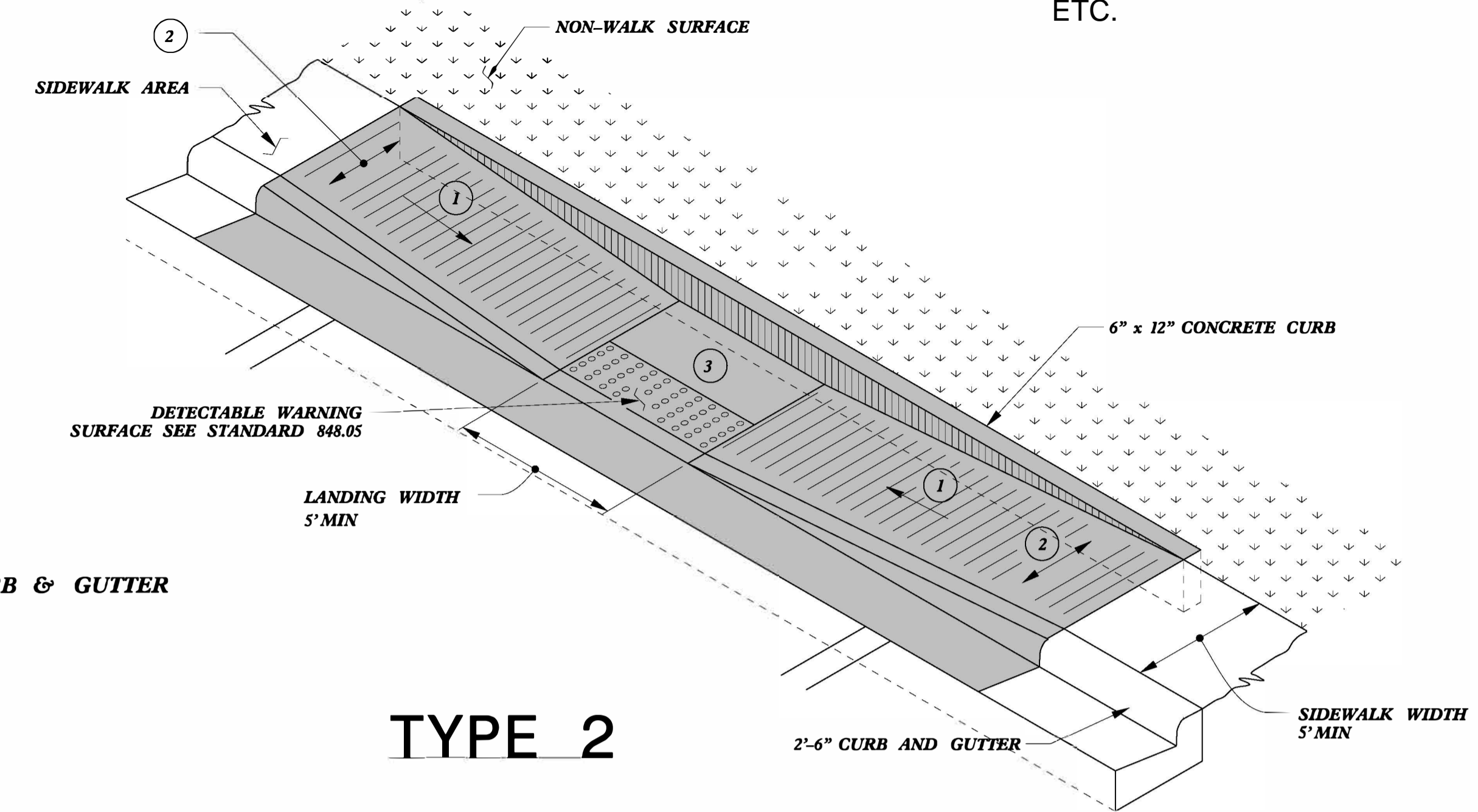

TYPE 2

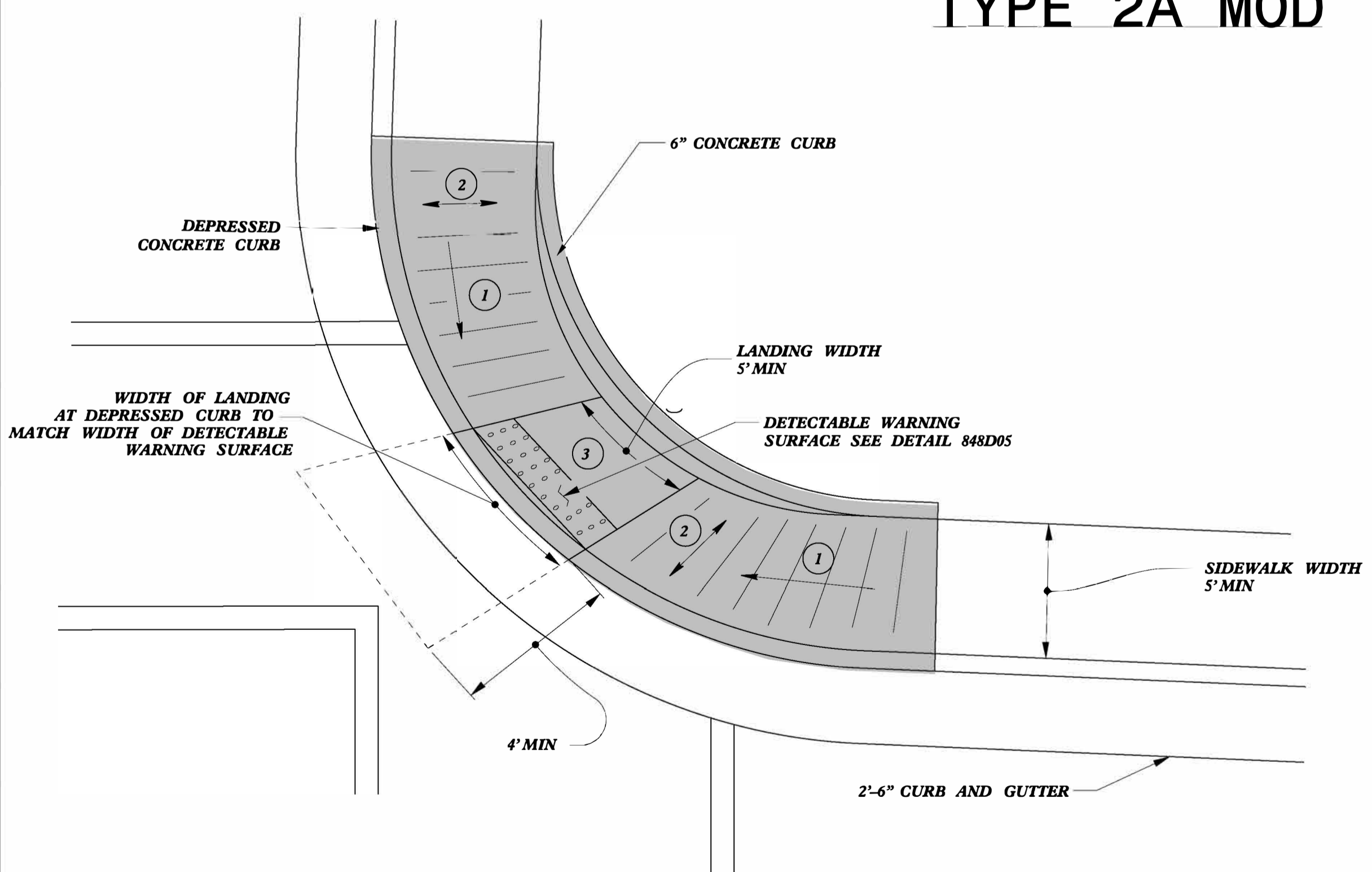

TYPE 2B

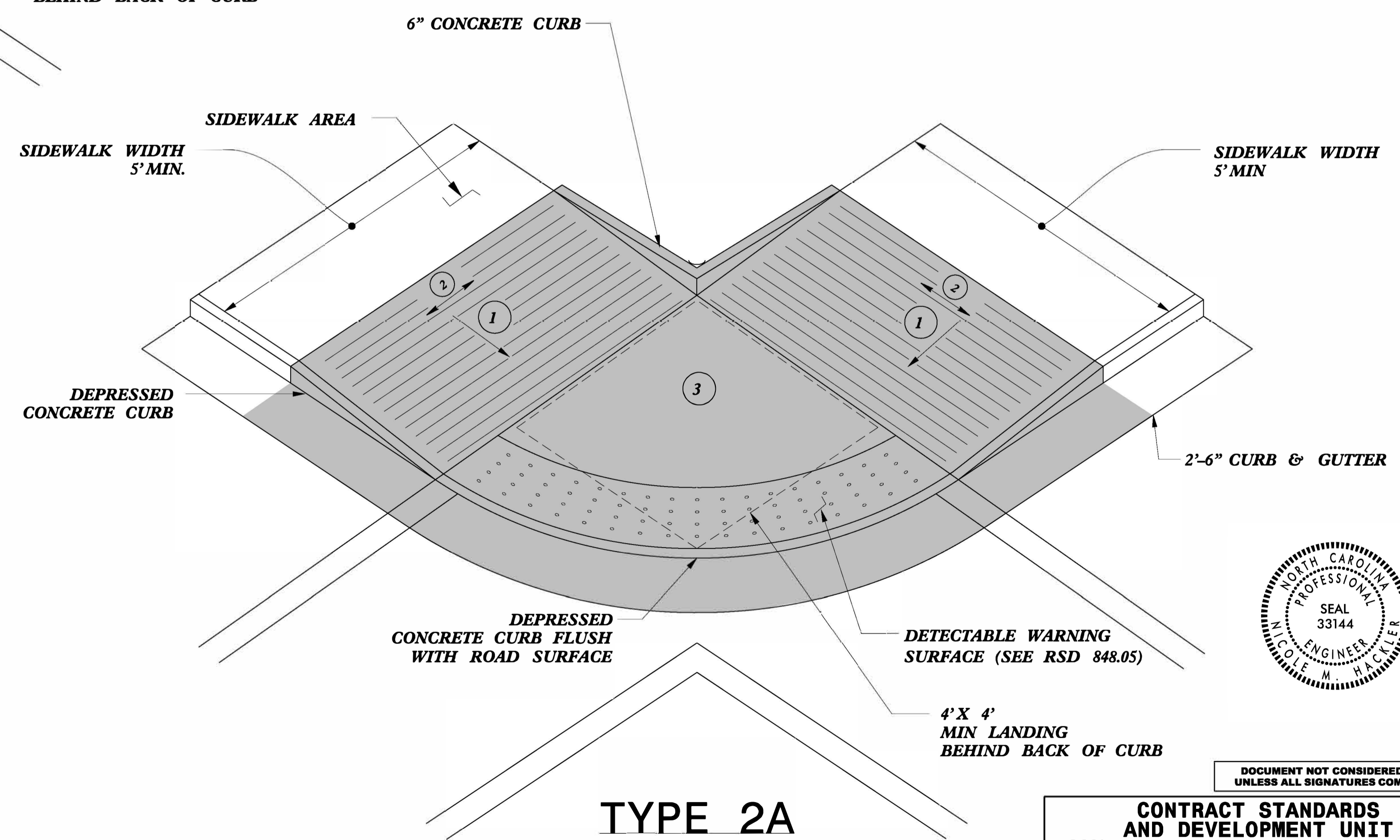

TYPE 2A



DOCUMENT NOT CONSIDERED FINAL UNLESS ALL SIGNATURES COMPLETED

CONTRACT STANDARDS AND DEVELOPMENT UNIT
Office 919-707-6950 FAX 919-250-4119

CURB RAMPS

ORIGINAL BY: J.S. HOWERTON DATE: 7/7/11
MODIFIED BY: DATE:
CHECKED BY: DATE:
FILE SPEC. stds/2012CurbRamp/CurbRampDetails.dgn

- 1 8.33% (12:1) MAX RAMP SLOPE
- 2 CROSS SLOPE: 2.00%
- 3 CURB RAMPS REQUIRE A (4'-0") MINIMUM LANDING WITH A MAXIMUM CROSS SLOPE AND LONGITUDINAL SLOPE OF 2.00% WHERE PEDESTRIANS PERFORM TURNING MANEUVERS. SLOPE TO DRAIN TO CURB.

PAY LIMITS FOR 1 CURB RAMP

5/14/99
 C:\P\2012\2012CurbRamp\CurbRampDetails.dgn

PAY LIMITS FOR 1 CURB RAMP

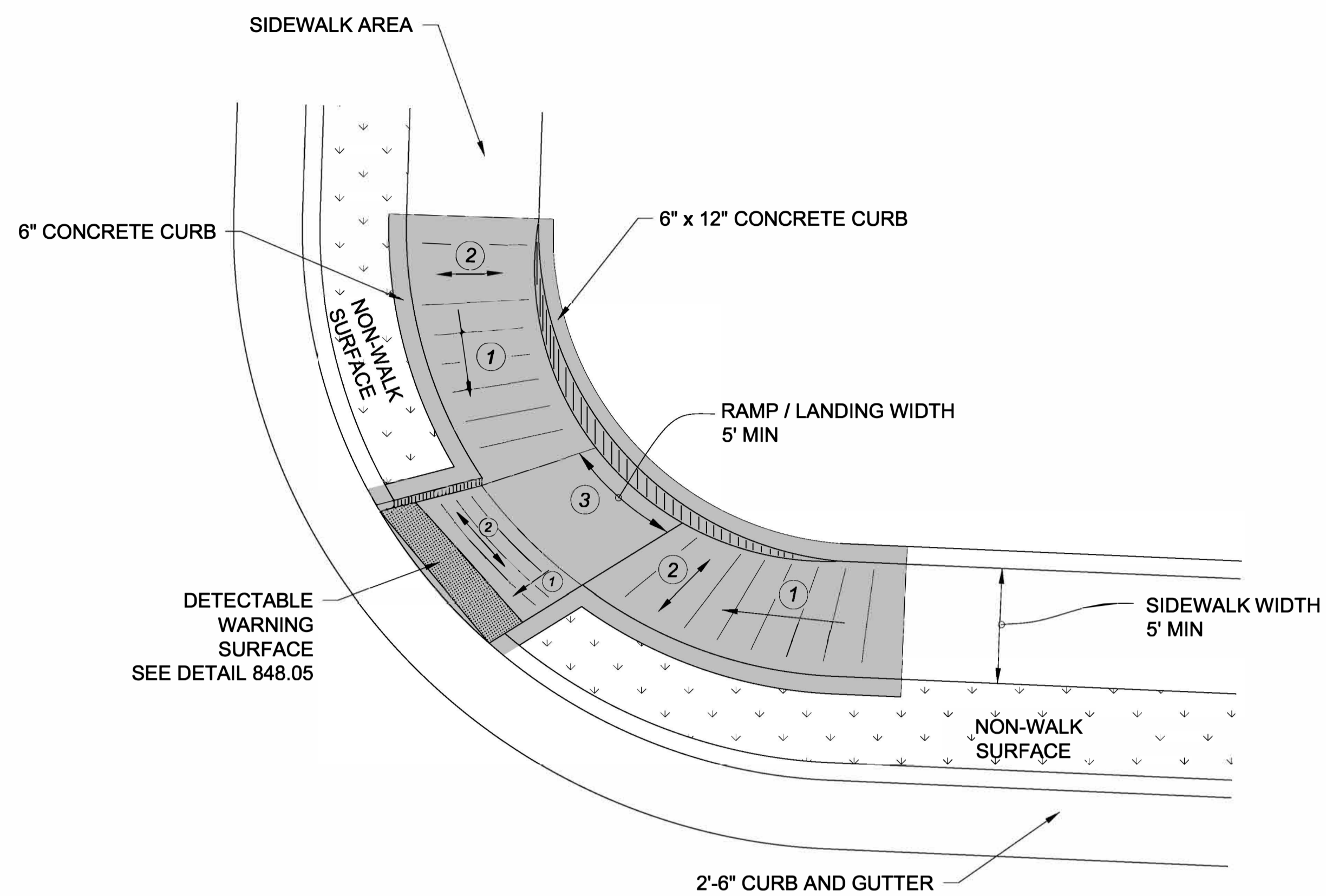

**TYPE 3 MODIFIED
INSTALLATION IN A RADIUS**

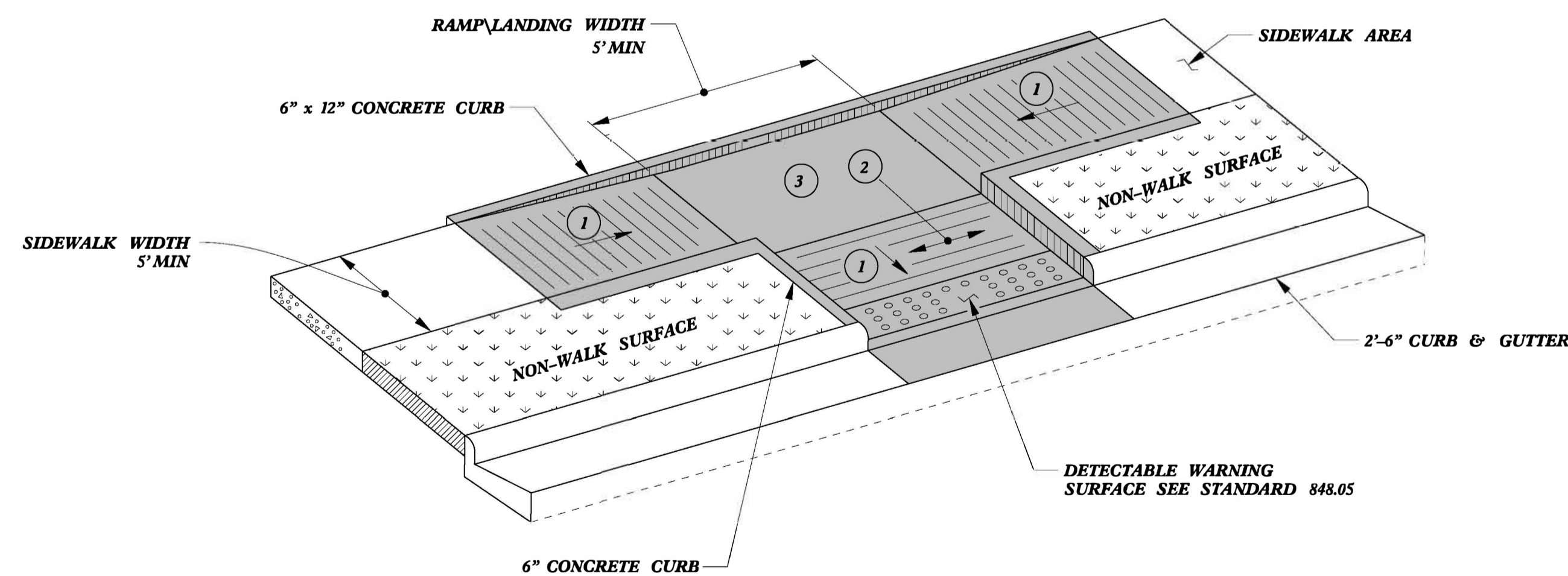

TYPE 3

- 1 8.33% (12:1) MAX RAMP SLOPE
- 2 CROSS SLOPE: 2.00%
- 3 CURB RAMPS REQUIRE A (4'-0") MINIMUM LANDING WITH A MAXIMUM CROSS SLOPE AND LONGITUDINAL SLOPE OF 2.00% WHERE PEDESTRIANS PERFORM TURNING MANEUVERS. SLOPE TO DRAIN TO CURB.

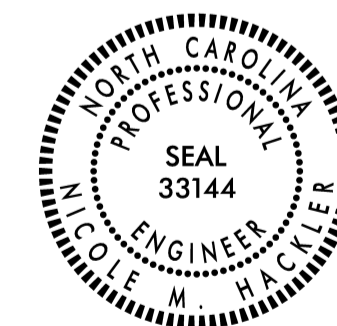

DOCUMENT NOT CONSIDERED FINAL
UNLESS ALL SIGNATURES COMPLETED

**CONTRACT STANDARDS
AND DEVELOPMENT UNIT**
Office 919-707-6950 FAX 919-250-4119

CURB RAMPS

ORIGINAL BY: J.S. HOWERTON DATE: 7/7/11
 MODIFIED BY: _____ DATE: _____
 CHECKED BY: _____ DATE: _____
 FILE SPEC. :stds/2012CurbRamp/CurbRampDetails.dgn

5/14/99
 1
 2
 3
 4
 5
 6
 7
 8
 9
 10
 11
 12
 13
 14
 15
 16
 17
 18
 19
 20
 21
 22
 23
 24
 25
 26
 27
 28
 29
 30
 31
 32
 33
 34
 35
 36
 37
 38
 39
 40
 41
 42
 43
 44
 45
 46
 47
 48
 49
 50
 51
 52
 53
 54
 55
 56
 57
 58
 59
 60
 61
 62
 63
 64
 65
 66
 67
 68
 69
 70
 71
 72
 73
 74
 75
 76
 77
 78
 79
 80
 81
 82
 83
 84
 85
 86
 87
 88
 89
 90
 91
 92
 93
 94
 95
 96
 97
 98
 99
 100

PAY LIMITS FOR 1 OR 2 CURB RAMPS
(CALCULATE BASED ON NUMBER OF SETS
OF TRUNCATED DOMES)

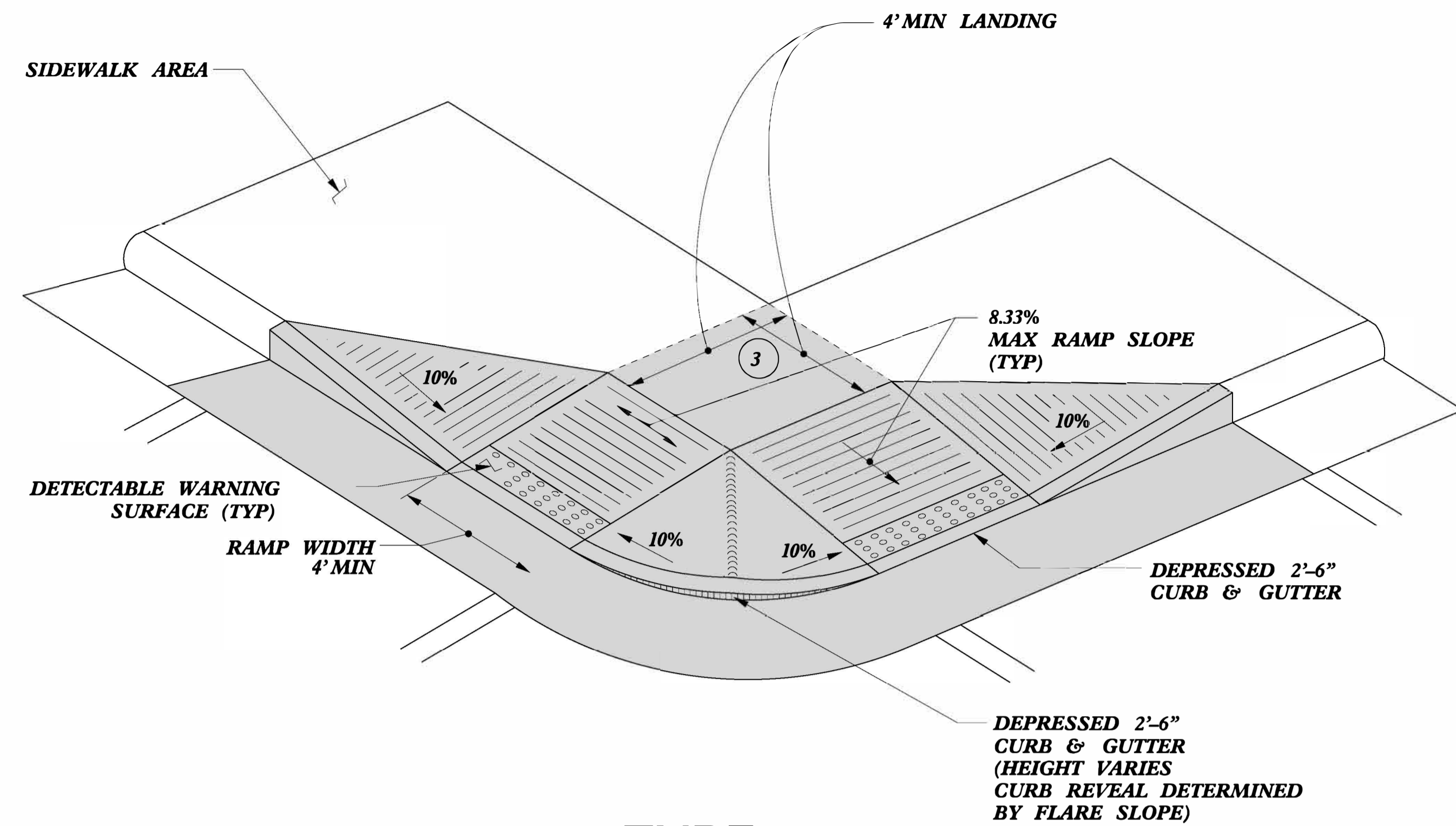

TYPE 4

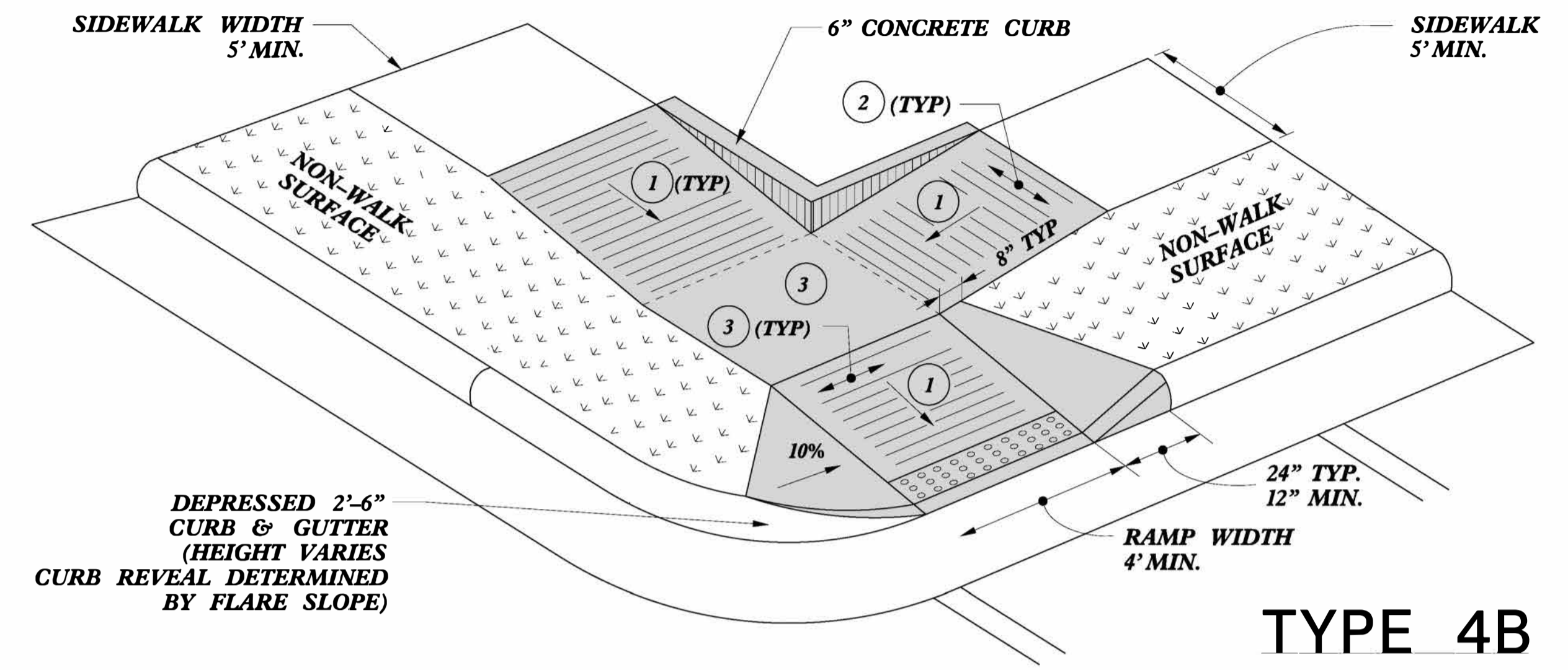

TYPE 4B

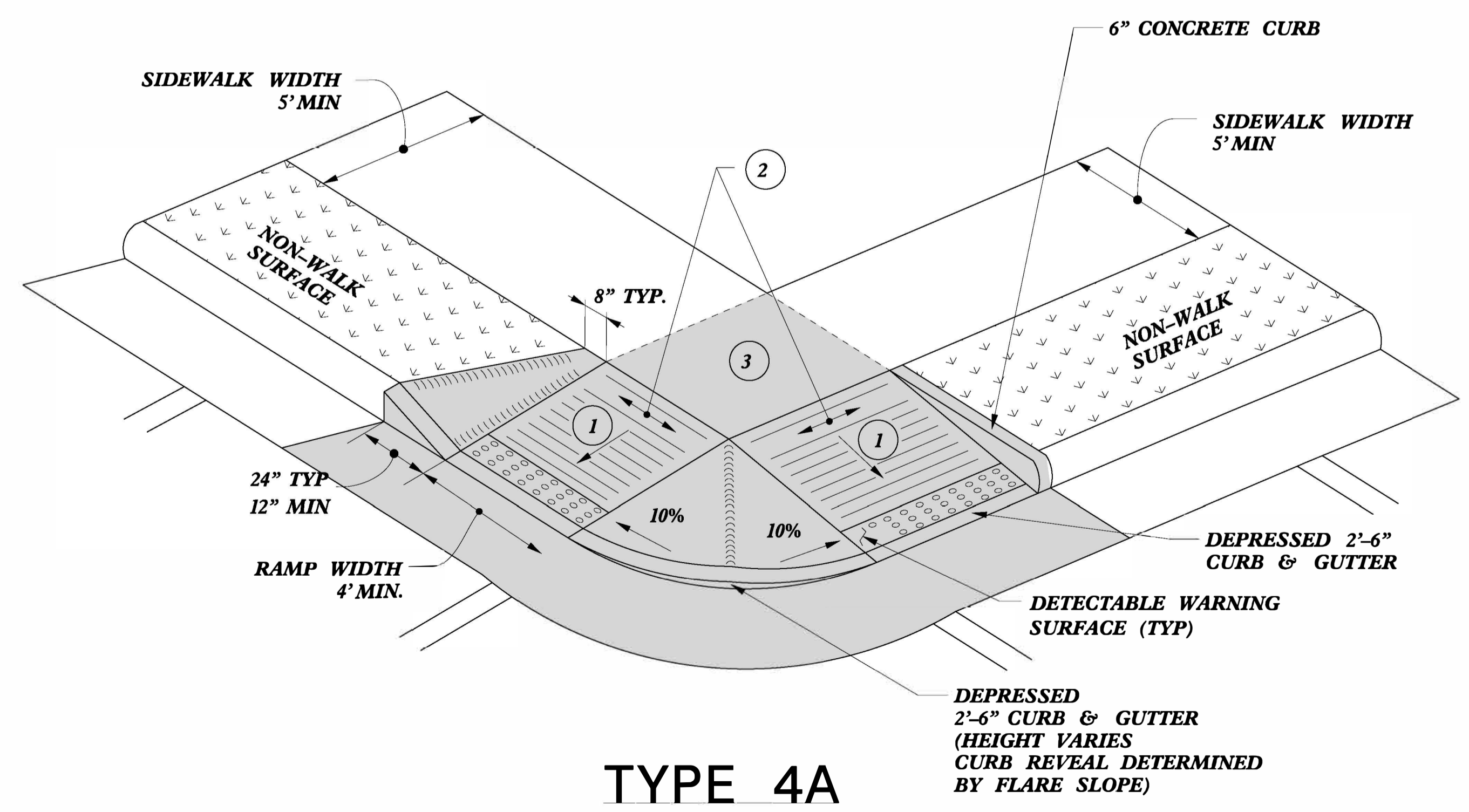

TYPE 4A

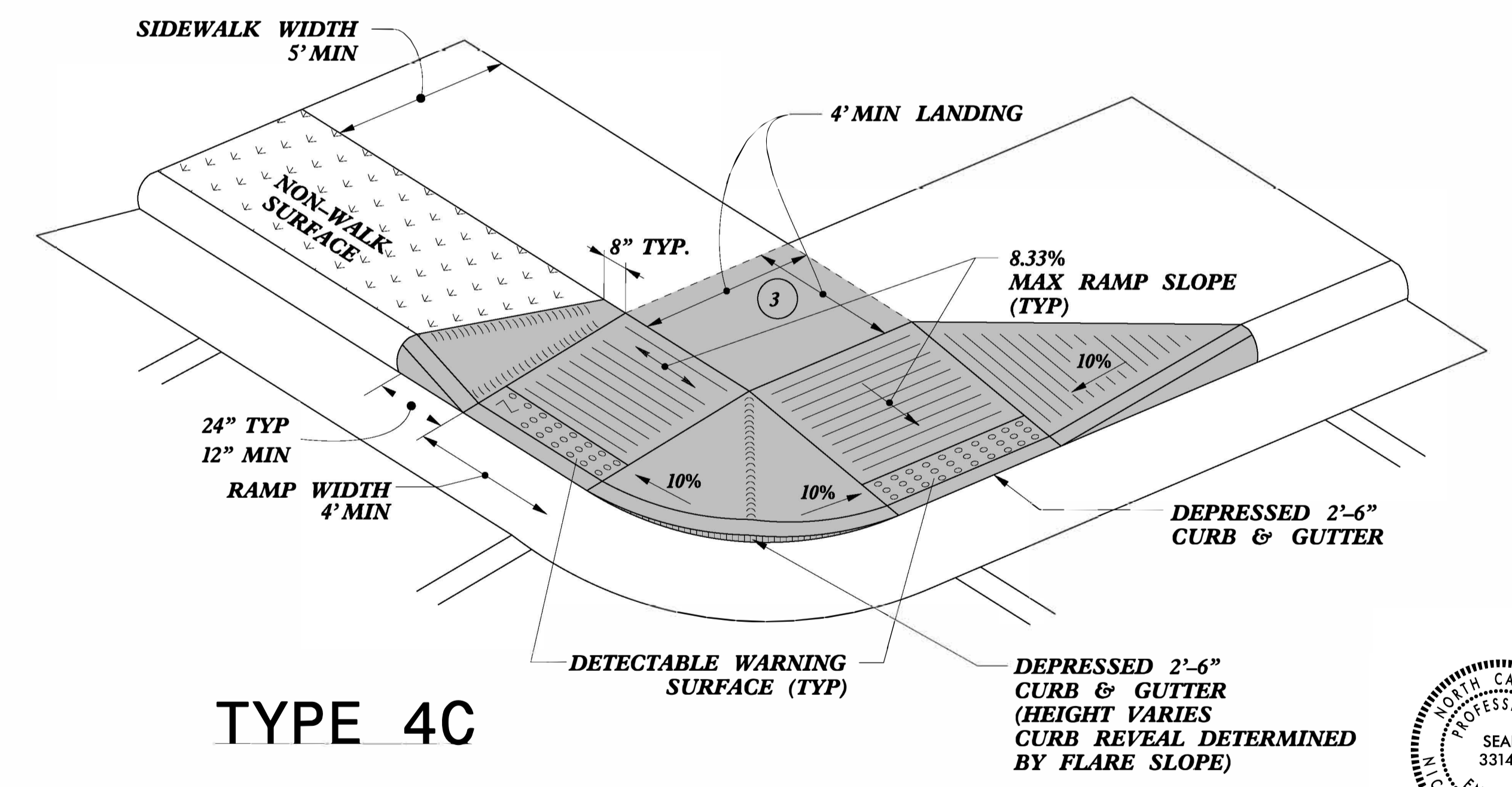

TYPE 4C

- 1 8.33% (12:1) MAX RAMP SLOPE
- 2 CROSS SLOPE: 2.00%
- 3 CURB RAMPS REQUIRE A (4'-0") MINIMUM LANDING WITH A MAXIMUM CROSS SLOPE AND LONGITUDINAL SLOPE OF 2.00% WHERE PEDESTRIANS PERFORM TURNING MANEUVERS. SLOPE TO DRAIN TO CURB.



DOCUMENT NOT CONSIDERED FINAL
UNLESS ALL SIGNATURES COMPLETED

**CONTRACT STANDARDS
AND DEVELOPMENT UNIT**
Office 919-707-6950 FAX 919-250-4119

CURB RAMPS

ORIGINAL BY: J.S. HOWERTON DATE: 7/7/11
 MODIFIED BY: DATE:
 CHECKED BY: DATE:
 FILE SPEC. :stds/2012CurbRamp/CurbRampDetails.dgn

REFER TO ROADWAY STANDARD DRAWING NUMBER 848.05 SHEET 3 OF 3 FOR ALL RAMP NOTES

5/14/99
 C:\TIME\5555\DWG\2012CurbRamp\CurbRampDetails.dgn
 PLOT: 2023CPT.12.05.10491.dwg
 PLOT DATE: 7/7/11 10:00 AM
 PLOT BY: J.S. HOWERTON
 PLOT SCALE: 1:1
 PLOT SHEET: 14 OF 14

PAY LIMITS FOR 1 OR 2 CURB RAMPS
(CALCULATE BASED ON NUMBER OF SETS
OF TRUNCATED DOMES)

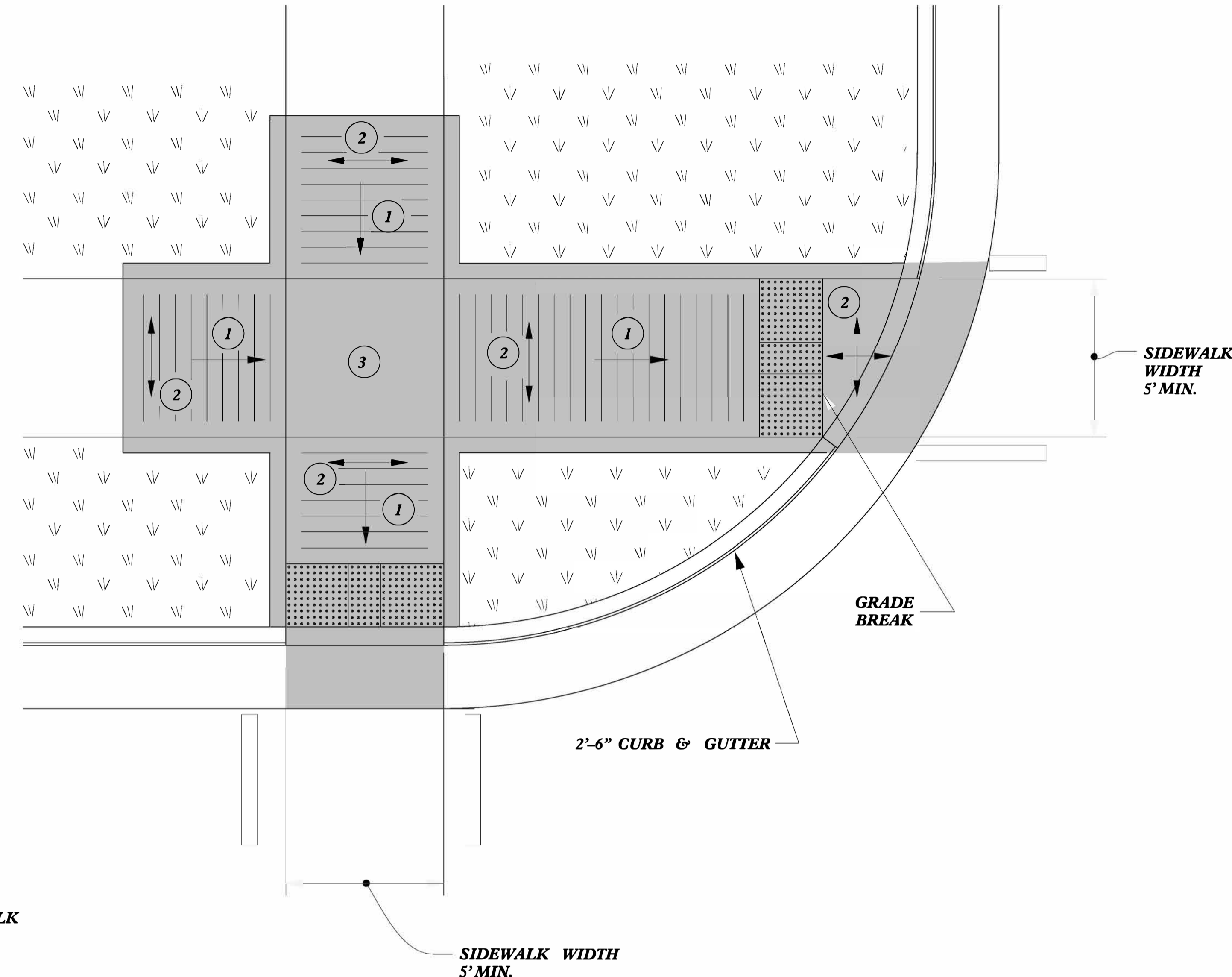

TYPE 5A

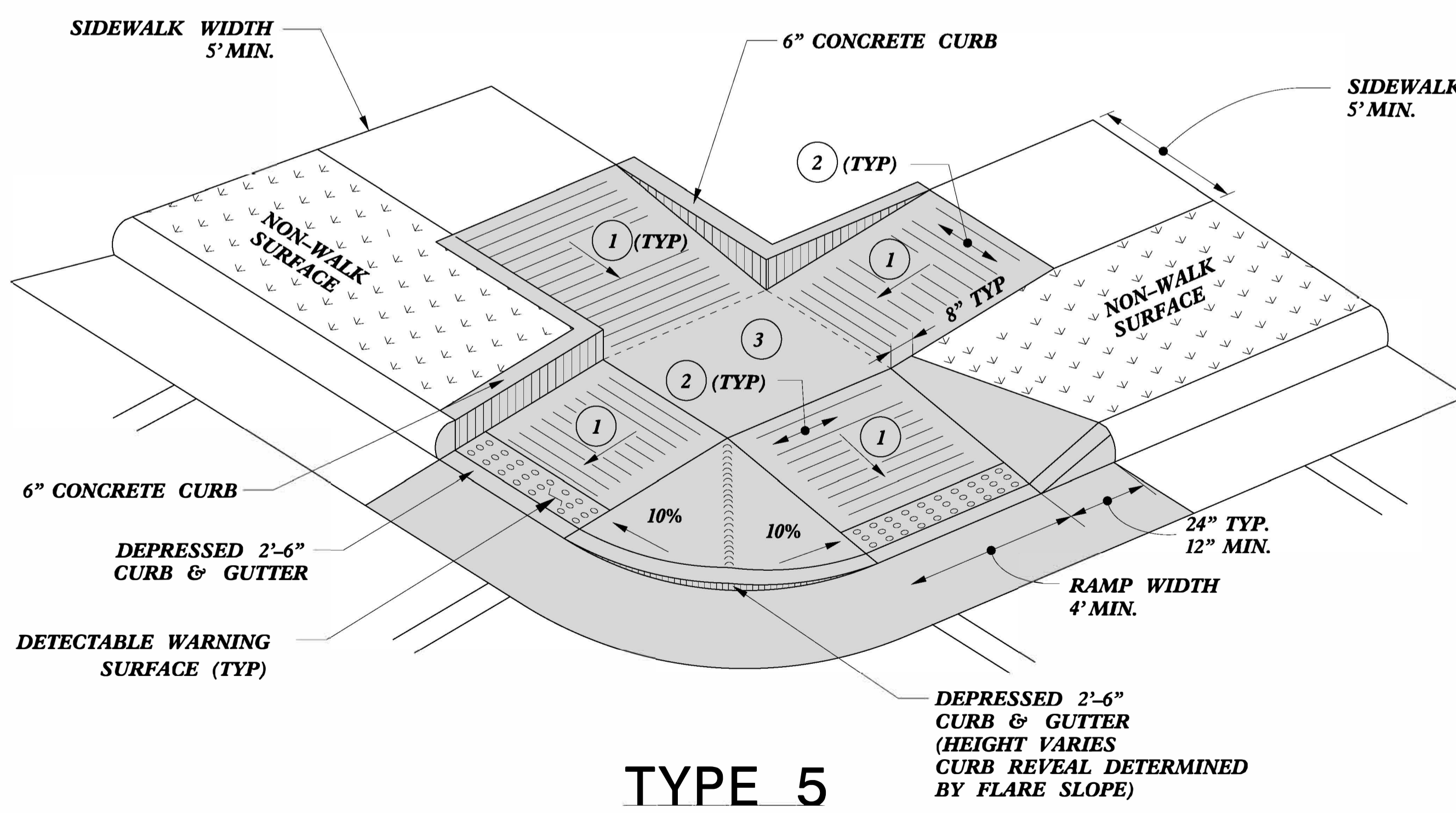

TYPE 5

- 1 8.33% (12:1) MAX RAMP SLOPE
- 2 CROSS SLOPE: 2.00%
- 3 CURB RAMPS REQUIRE A (4'-0") MINIMUM LANDING WITH A MAXIMUM CROSS SLOPE AND LONGITUDINAL SLOPE OF 2.00% WHERE PEDESTRIANS PERFORM TURNING MANEUVERS. SLOPE TO DRAIN TO CURB.



CONTRACT STANDARDS AND DEVELOPMENT UNIT
Office 919-707-6950 FAX 919-250-4119

CURB RAMPS

ORIGINAL BY: J.S. HOWERTON DATE: 7/7/11
MODIFIED BY: _____ DATE: _____
CHECKED BY: _____ DATE: _____
FILE SPEC: stds/2012CurbRamp/CurbRampDetails.dgn

REFER TO ROADWAY STANDARD DRAWING NUMBER 848.05 SHEET 3 OF 3 FOR ALL RAMP NOTES

5/14/99
SYTIME
DU
SUGERNAVE

SIGNING FOR RESURFACING PROJECTS

LEGEND

┃ STATIONARY SIGN

← DIRECTION OF TRAFFIC FLOW

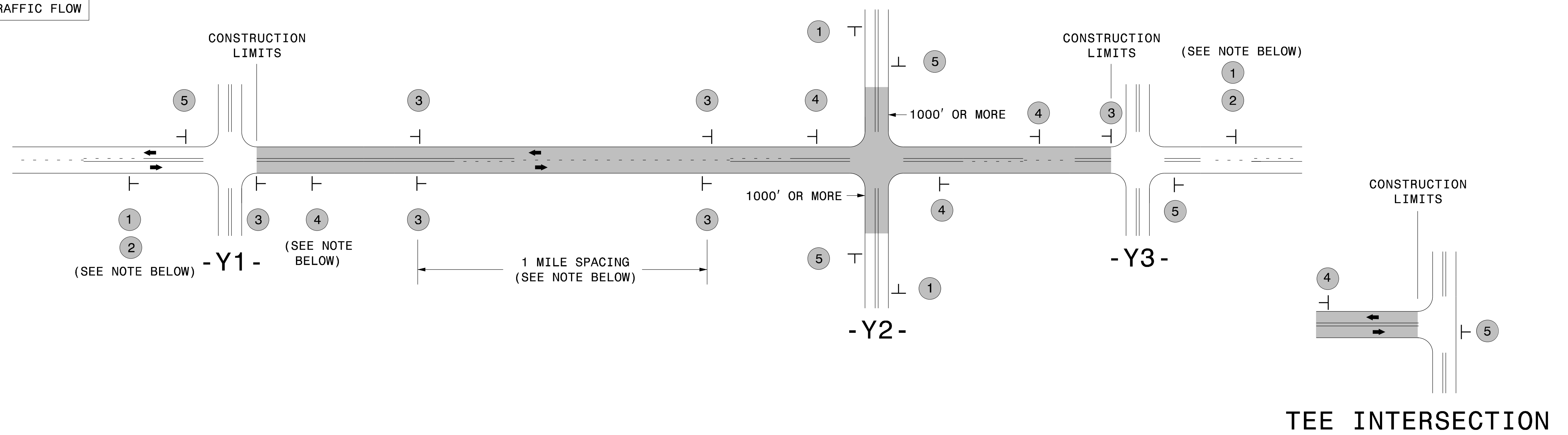

MAINLINE (-L-) SIGNING

-Y- LINE SIGNING

SIGNING NOTES AND PLACEMENT PER DIRECTION	1		PLACE 1000' PRIOR TO BEGINNING OF CONSTRUCTION LIMITS. ONLY USED ON -Y- LINES IF RESURFACING LIMITS EXTEND 1000' ALONG -Y- LINE.	<p>NO REQUIRED STATIONARY SIGNING FOR THE FOLLOWING -Y- LINE CONDITIONS:</p> <ol style="list-style-type: none"> LESS THAN 1000' OF RESURFACING ALONG -Y- LINE SUBDIVISION ROADS DEAD END ROADS <p>WHEN PAVING/CONSTRUCTION ACTIVITIES PROCEED ACROSS AN UNSIGNED -Y- LINE, PORTABLE ADVANCE WARNING SIGNS SHALL BE USED ALONG THE -Y- LINE AS SHOWN BELOW. REMOVE UPON COMPLETION OF WORK.</p> <div style="display: flex; justify-content: space-around;"> <div style="text-align: center;"> PLACED 500' IN ADVANCE OF FLAGGER. </div> <div style="text-align: center;"> PLACED 250' IN ADVANCE OF FLAGGER. </div> </div>
	2		#2 SIGN ONLY USED WHEN CONSTRUCTION LIMITS ARE 2 OR MORE MILES IN LENGTH. ROUND UP TO NEXT WHOLE NUMBER. (NO FRACTIONAL OR DECIMAL NUMBERS)	
	3		<ul style="list-style-type: none"> PLACE INITIALLY AT THE CONSTRUCTION LIMITS AND SPACE 1 MILE APART THEREAFTER. AT TEE INTERSECTIONS INSTALL INITIALLY 1/2 MILE FROM INTERSECTION AND SPACE 1 MILE APART THEREAFTER. 	
	4		<ul style="list-style-type: none"> THESE ARE FOR -Y- LINES THAT ARE "THROUGH" ROADWAYS. DEAD END AND SUBDIVISION ROADS ARE NOT "THROUGH" ROADWAYS. INSTALL 500' +/- FROM EACH -Y- LINE APPROACH AS SHOWN ABOVE. FOR MULTIPLE -Y- LINES THAT ARE SEPARATED BY 0.25 MILES OR LESS, TREAT AS A SINGLE UNIT AND INSTALL WITHIN 500' OF EACH APPROACH. A MAXIMUM OF 2 SIGN SETS PER MILE. DO NOT INSTALL WHEN -Y- LINES ARE WITHIN 0.5 MILES FROM "END ROAD WORK" SIGN. FOR TEE INTERSECTIONS, INSTALL WITHIN 500' +/- OF THE INTERSECTION ALONG -L- LINE. 	
	5		PLACE 500' FOLLOWING THE END OF CONSTRUCTION LIMITS OR AS SHOWN WHEN WORK ENDS AT A 3-WAY TEE INTERSECTION.	

THE ABOVE SIGNS ARE ALL THAT ARE REQUIRED FOR A CONTRACTOR TO BEGIN A RESURFACING CONTRACT. ANY ADDITIONAL SIGNS REQUESTED BY NCDOT DIVISIONS SHALL BE INSTALLED WITHIN 7 BUSINESS DAYS OF THE START OF CONTRACT WORK.

MAPS LESS THAN 2 MILES

FOR RESURFACING MAPS WITH CONSTRUCTION LIMITS LESS THAN 2 MILES IN LENGTH, NO STATIONARY SIGNS ARE REQUIRED. USE PORTABLE "ROAD UNDER CONSTRUCTION" OR "ROAD WORK AHEAD" SIGNS IN LIEU OF STATIONARY ADVANCE WARNINGS SIGNS.

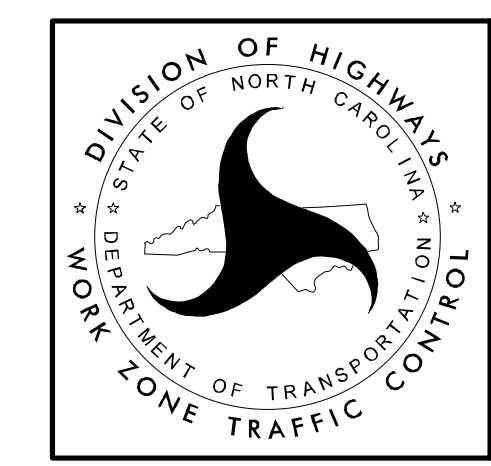

ADVANCE WARNING SIGNS FOR RURAL AND SUBURBAN 2-LANE ROADWAY RESURFACING

5/15/2017 S:\TMU\WZTC\Resurfacing\2L2W & AST Resurfacing Details\Resurfacing_AdvWarn_2Ln.dgn User:kadai

DIVIDED MEDIANS WITH WIDTHS 46' OR GREATER

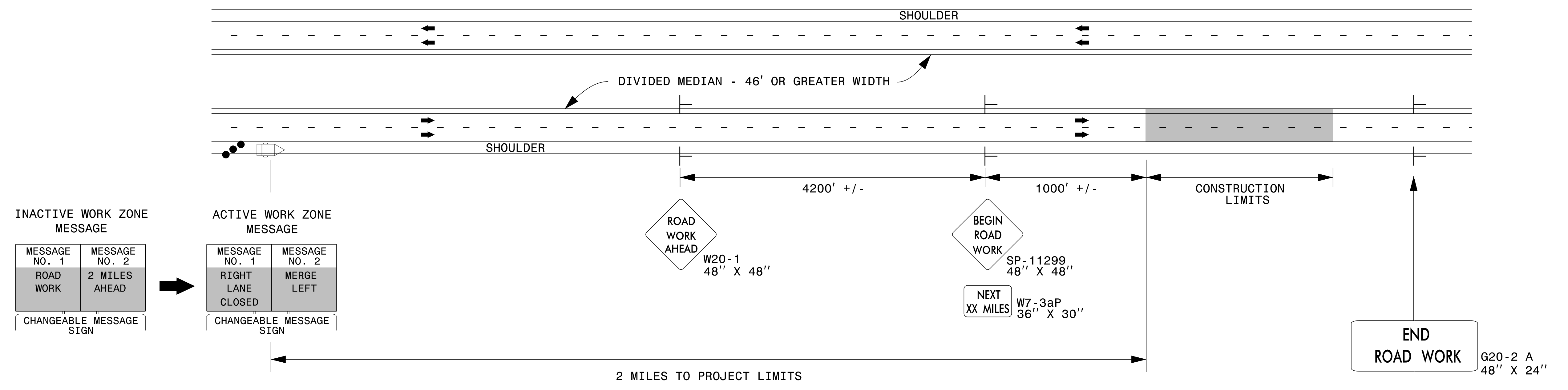

DIVIDED MEDIANS WITH WIDTHS LESS THAN 46' OR WITH PERMANENT MEDIAN BARRIER

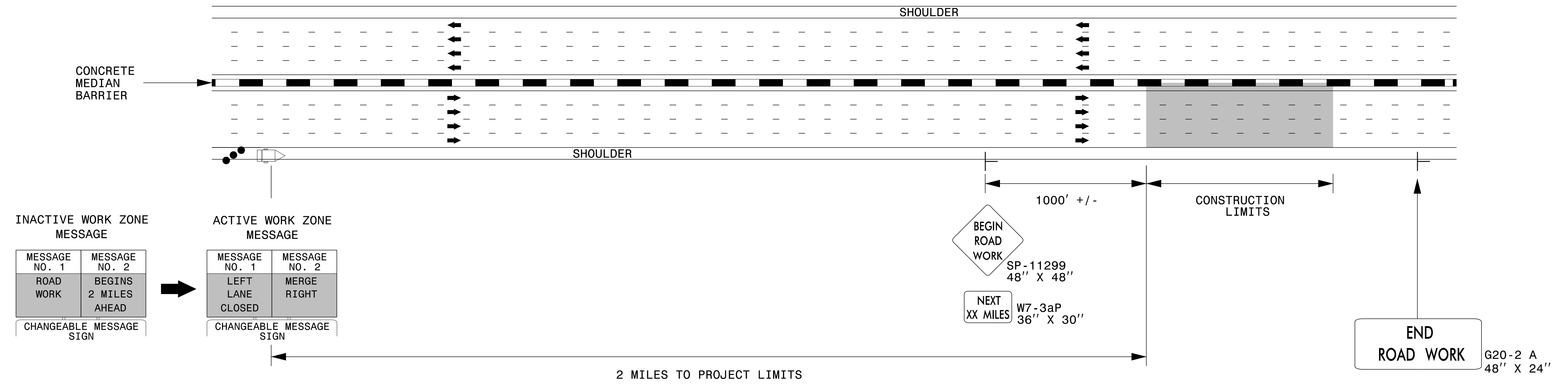

NOTES:

- 1) LATERAL CLEARANCE AT ALL SIGN LOCATIONS SHALL BE 6' AS MEASURED FROM THE EDGE OF PAVEMENT.
- 2) MOUNT SIGNS THAT ARE LARGER THAN 10 SQUARE FEET IN AREA ON TWO OR MORE WOOD OR U-CHANNEL SUPPORTS. PERFORATED SQUARE TUBING SUPPORT SYSTEMS MAY SUPPORT LARGER AREAS ON A SINGLE SUPPORT. FOLLOW MANUFACTURER'S RECOMMENDATIONS. THESE SYSTEMS SHALL BE NCHRP 350 COMPLIANT AND NCDOT APPROVED.
- 3) FOR MEDIAN WIDTHS LESS THAN 46' (MEASURED EDGELINE TO EDGELINE) USE THE BOTTOM DRAWING.
- 4) IF STATIONARY GENERAL WARNING SIGNS ARE USED, THEY WILL BE PAID FOR PER SECTION 104 OF THE NCDOT STANDARD SPECIFICATIONS AS EXTRA WORK.
- 5) INSTALL "ROAD WORK AHEAD" (W20-1) ALONG ENTRANCE RAMP 500' PRIOR TO RAMP TERMINAL, AND "END ROAD WORK" (G20-2a) AT THE END OF EXIT RAMP WITHIN THE WORK ZONE.
- 6) IF MILLED AREAS ARE NOT PAVED BACK BY THE END OF THE WORK DAY, PORTABLE SIGNS SHALL BE USED TO WARN DRIVERS OF THE PRESENT CONDITIONS. THESE ARE TO INCLUDE, BUT NOT LIMITED TO "ROUGH ROAD" W8-8, "UNEVEN LANES" W8-11, "GROOVED PAVEMENT" W8-15 w/MOTORCYCLE PLAQUE MOUNTED BELOW. THESE ARE TO BE DOUBLE INDICATED ON MULTI-LANE ROADWAYS WITH SPEED LIMITS 45 MPH AND GREATER AND WITH DIVIDED MEDIANS OF 46' OR GREATER. THESE PORTABLE SIGNS ARE INCIDENTAL TO THE OTHER ITEMS OF WORK INCLUDED IN THE TEMPORARY TRAFFIC CONTROL (LUMP SUM) PAY ITEM.

LEGEND

- CHANGEABLE MESSAGE SIGN (CMS)
- STATIONARY SIGN
- DIRECTION OF TRAFFIC FLOW
- TRAFFIC DRUM

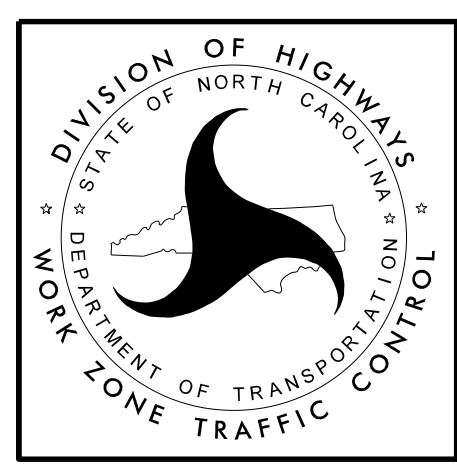

**RESURFACING ADVANCE
WARNING SIGNS FOR
HIGH SPEED FACILITIES
≥ 60 MPH**

3/23/2015 C:\Users\rmgarrrett\Downloads\Resurfacing_AdvWarn_HSpd.dgn User:rmgarrrett

High Speed Detection (≥40 mph)

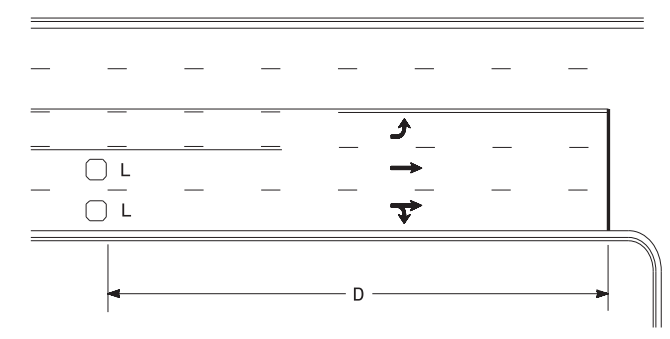

Speed Limit mph	D ft
40	250
45	300
50	355
55	420

L = 6ft X 6ft
Wired separately

Volume Density Operation

OR

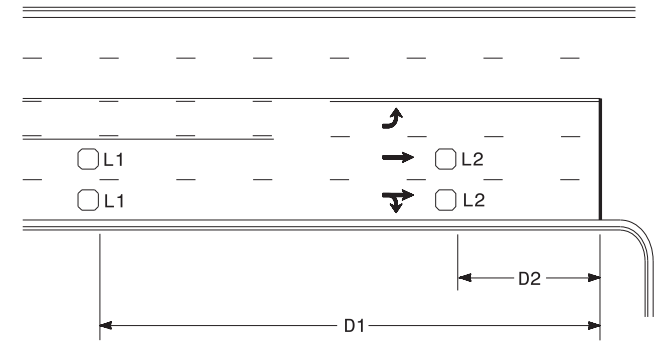

Speed Limit mph	D1 ft	D2 ft
40	250	80
45	300	90
50	355	100
55	420	110

L1 = 6ft X 6ft
Wired in series

L2 = 6ft X 6ft
Wired in series

"Stretch" Operation

Low Speed Detection (≤35 mph)

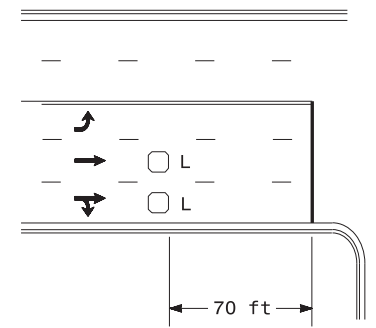

L = 6ft X 6ft
Wired in series

OR

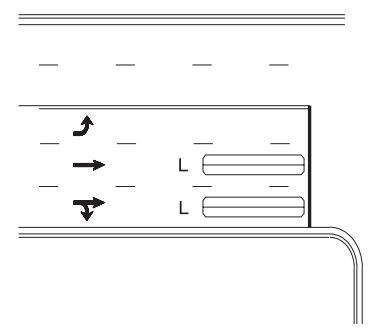

L = 6ft X 40ft
Quadrupole loop, wired separately

Left Turn Lane Detection

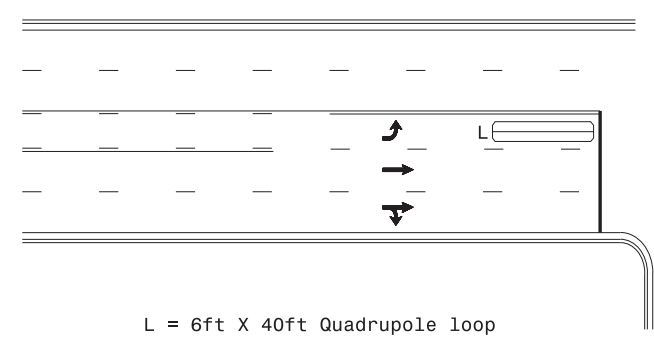

L = 6ft X 40ft Quadrupole loop

Presence Loop Detection

OR

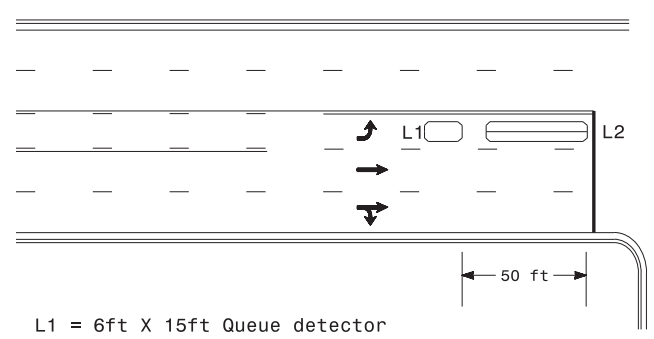

L1 = 6ft X 15ft Queue detector
L2 = 6ft X 40ft Quadrupole loop

Queue Loop Detection

Right Turn Lane Detection

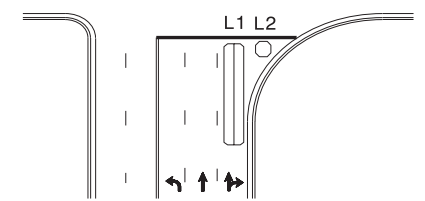

Shared Lane/
Wide Radius Turn

L1 = 6ft X 40ft Quadrupole loop
L2 = 6ft X 6ft [Minimum] Presence loop
Wired separately

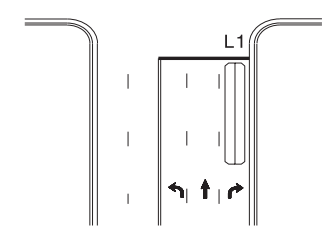

Standard Turn

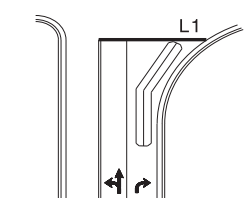

Wide Radius Turn

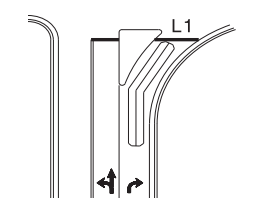

Channelized Turn

Side Street Detection

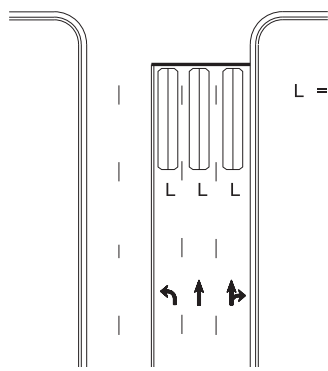

L = 6ft X 40ft
Quadrupole loop
Wired to separate
detectors/channels

Presence Loop Placement at Stop Lines

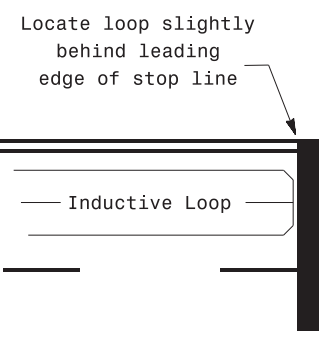

Note:
Loop may be located in advance of stop line under any of the following conditions:
1) stop line is greater than 15' from edge of intersecting roadway
2) loop detects a permissive or protected/permissive left turn
3) for an exclusive right turn lane

Recommended Number of Turns

Single 6' X 6' loop
(when wired separately):

Length of Lead-in ft	Number of Turns
< 250	3
250-375	4
375-525	5
> 525	6

Quadrupole loops: Use 2-4-2 turns

6' X 15' Loops:
Lead-in < 150', use 2 turns
Lead-in > 150', use 3 turns

09-SEP-2020 11:54 S:\MITS\SIG\15\SIGNAL\SIGNAL Design Section\Eastern Region\Loop Typo\cal\looptypo\cal2015.dgn JGallaway

	<p>Prepared In the Offices of:</p> <p>PLANNING, MOBILITY AND SAFETY DIVISION STATE OF NORTH CAROLINA SIGNAL DESIGN SECTION 750 N. Greenfield Pkwy, Garner, NC 27529</p>		<p>SEAL NORTH CAROLINA PROFESSIONAL ENGINEER 029904 JASON P. GALLOWAY</p>	
	<p>PLAN DATE: September 2020</p>		<p>REVIEWED BY: JPG</p>	
<p>PREPARED BY: PLA</p>		<p>REVIEWED BY:</p>		
<p>SCALE N/A</p>	<p>REVISIONS</p>	<p>INIT.</p>	<p>DATE</p>	
<p>9/8/2020</p>		<p>DATE</p>		
<p>SIG. INVENTORY NO.</p>				