

p:\gfn\p-w\ben\p-w-01\Documents\Projects\67945\5-Working\Task 010 - I-5955 Greensboro Rehab\Structures\CAD\2.0 100% Plans\409_013_I-5955_SMU_JT_007_400348
 I:\7/2022 9:57:45 AM pdf_color_gfclt_FS.plt I-5955.tbl

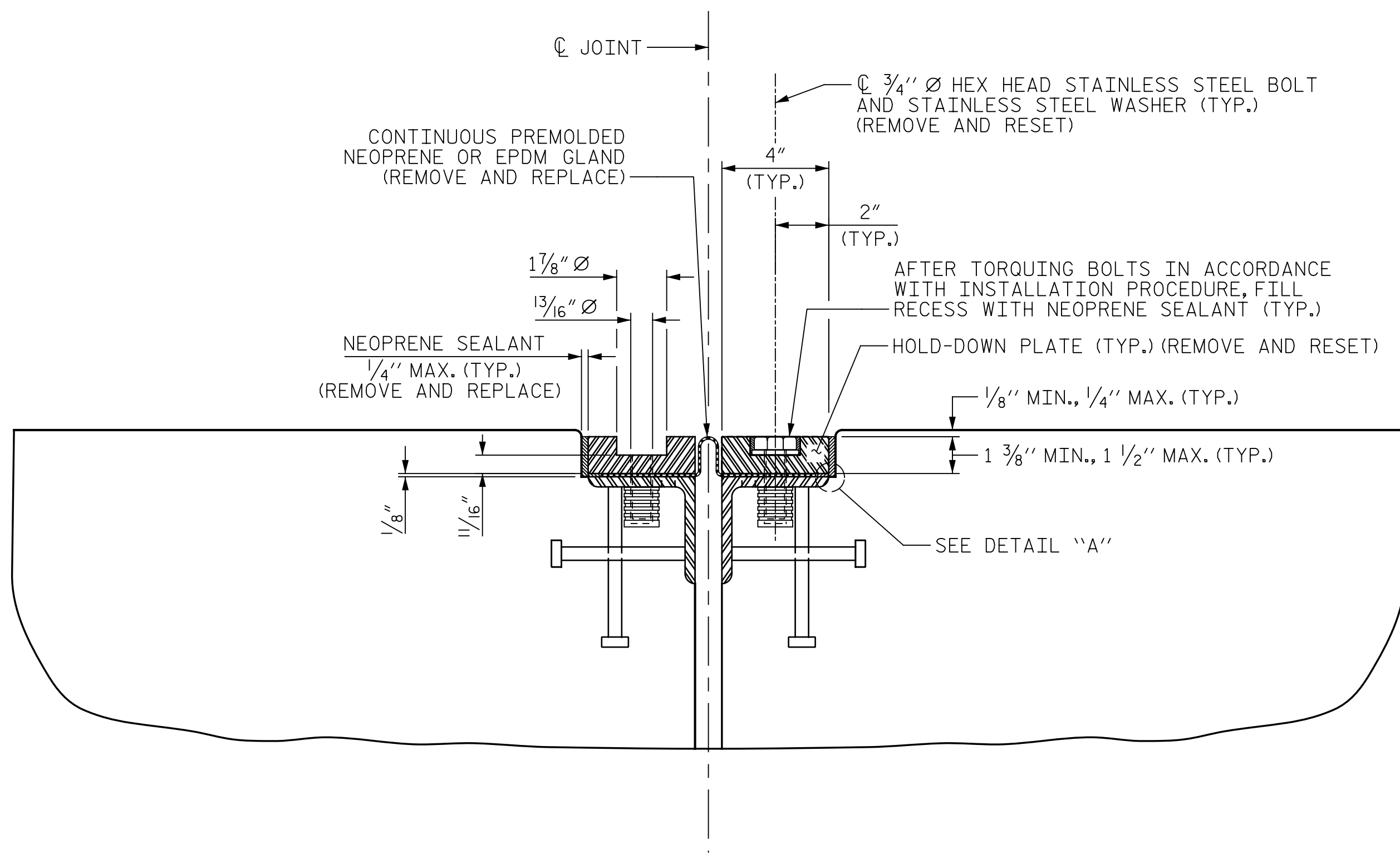

SECTION E-E

SECTION NORMAL TO JOINT -- STEEL SUPERSTRUCTURE

REPAIR INSTALLATION PROCEDURE

LOOSEN THE EXISTING BOLTS AND HOLD-DOWN PLATES TO REMOVE AND REPLACE THE EXISTING GLAND. REMOVE THE EXISTING NEOPRENE SEALANT AND CLEAN THE EXISTING BASE ANGLE OF OIL, GREASE AND OTHER LATENTS.

LAY THE NEW GLAND ON THE BASE ANGLE AND FIELD MARK THE NEW GLAND FOR THE BOLT HOLES. HOLES IN THE NEW GLAND SHALL BE PUNCHED $\frac{7}{8}$ " IN DIAMETER WITH A HAND PUNCH.

IN ORDER TO CHECK FOR PROPER ALIGNMENT, PLACE THE NEW GLAND HOLD-DOWN PLATES ON THE BASE ANGLE. DO NOT APPLY NEW NEOPRENE SEALANT. BOLT THE HOLD-DOWN PLATES TO THE BASE ANGLE, BUT DO NOT TIGHTEN. THE ENGINEER WILL INSPECT THE JOINT SEAL DEVICE FOR PROPER ALIGNMENT.

AFTER INSPECTION, REMOVE THE HOLD-DOWN PLATES AND NEW GLAND. APPLY NEW NEOPRENE SEALANT TO THE BASE ANGLE IN ACCORDANCE WITH THE "INSTALLATION SKETCH". PLACE NEW GLAND AND HOLD-DOWN PLATES ON THE BASE ANGLE. BOLT THE HOLD-DOWN PLATES TO THE BASE ANGLE ASSEMBLY AND TORQUE THE BOLTS TO 88 FT-LBS WITH A TORQUE WRENCH. CHECK THE TORQUE AFTER THREE (3) HOURS AND, IF NECESSARY, RETIGHTEN TO 88 FT-LBS. A FINAL CHECK SHALL BE MADE AT SEVEN (7) DAYS. TORQUE SHALL NOT BE LESS THAN 80 FT-LBS AFTER SEVEN (7) DAYS.

AFTER PROPER TORQUING, CLEAN THE BOLT HOLE RECESSES AND THE RECESS BETWEEN THE JOINT SEAL DEVICE AND CONCRETE. COMPLETELY FILL THESE RECESSES WITH NEW NEOPRENE SEALANT.

GENERAL NOTES

ALL HOLD-DOWN BOLTS SHALL CONFORM TO ASTM F593 ALLOY 304 STAINLESS STEEL AND WASHERS SHALL CONFORM TO ASTM F844 EXCEPT THEY SHALL BE MADE FROM ALLOY 304 STAINLESS STEEL.

A PREMOLDED CORRUGATED OR NON-CORRUGATED GLAND SHALL BE USED FOR JOINTS SKEWED BETWEEN 50° THRU 130° . FOR JOINTS SKEWED LESS THAN 50° OR MORE THAN 130° , ONLY A CORRUGATED GLAND SHALL BE USED.

THE FINISHED EXPANSION SEAL DEVICE SHALL BE A MINIMUM $\frac{1}{8}$ " AND A MAXIMUM OF $\frac{1}{4}$ " BELOW THE TOP OF SLAB.

FOR EXPANSION JOINT SEAL REPAIR, SEE SPECIAL PROVISIONS.

NO SEPARATE PAYMENT WILL BE MADE FOR REMOVING AND REINSTALLING MEDIAN AND BARRIER RAIL COVER PLATES. THE ENTIRE COST OF THIS WORK SHALL BE INCLUDED IN THE UNIT PRICE BID FOR "EXPANSION JOINT SEAL REPAIR".

CLEAN AND REMOVE DEBRIS FROM THE TOP OF THE BENT CAP AND APPLY EPOXY PROTECTIVE COATING. EPOXY COATING SHALL BE APPLIED TO THE TOP SURFACE OF THE CAP. THE CONTRACTOR SHALL NOT COAT THE AREA OF THE CAP BENEATH THE ELASTOMERIC BEARINGS AND MASONRY PLATES. FOR EPOXY COATING, SEE SPECIAL PROVISIONS.

MOVEMENT AND SETTING AT JOINT

LOCATION	SKEW ANGLE	TOTAL MOVEMENT (ALONG ϕ RDWY)	PERPENDICULAR JOINT OPENING AT 45° F	PERPENDICULAR JOINT OPENING AT 60° F	PERPENDICULAR JOINT OPENING AT 90° F
BENT 1	$154^{\circ}-50'-57"$	$\frac{9}{16}"$	$1\frac{1}{8}"$	$1\frac{13}{16}"$	$1\frac{3}{4}"$

SUMMARY OF QUANTITIES

LOCATION	EXPANSION JOINT SEAL REPAIRS		EPOXY COATING	
	ESTIMATED (LIN. FT)	ACTUAL (LIN. FT)	ESTIMATED (SQ. FT)	ACTUAL (SQ. FT)
BENT 1	134.0		395	

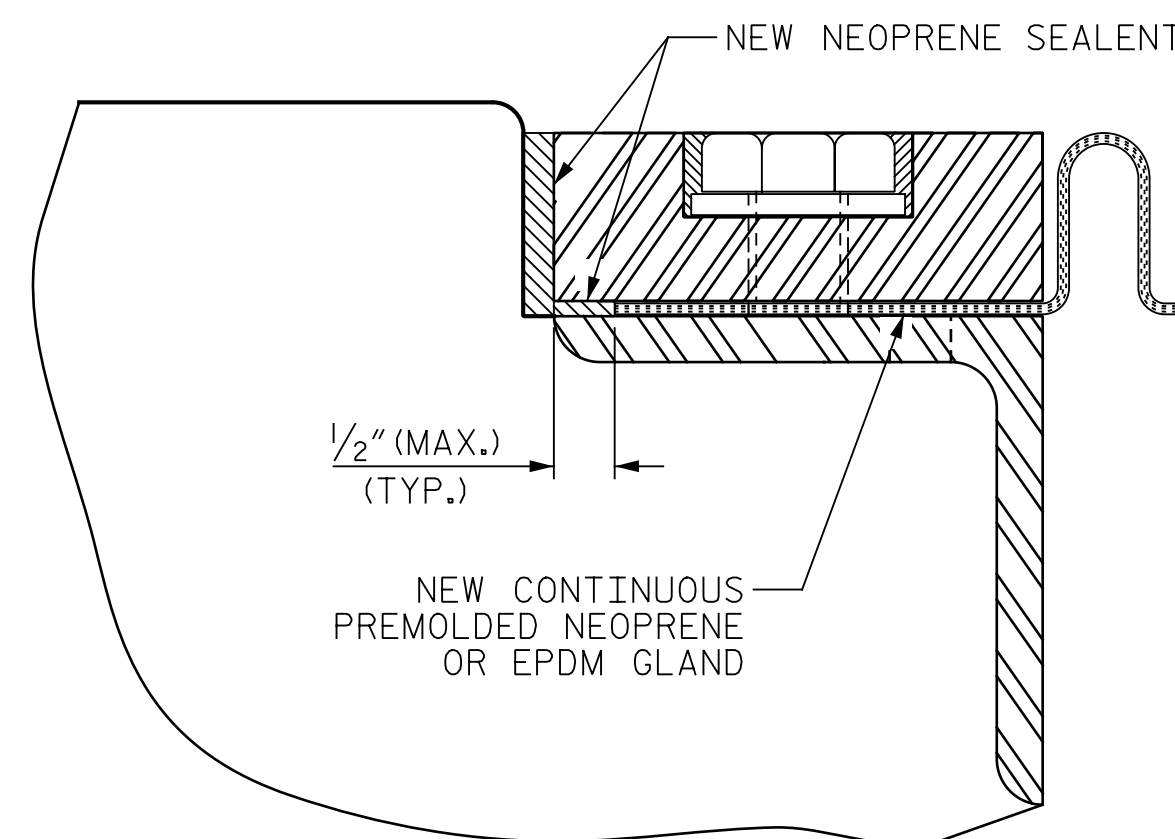

DETAIL A

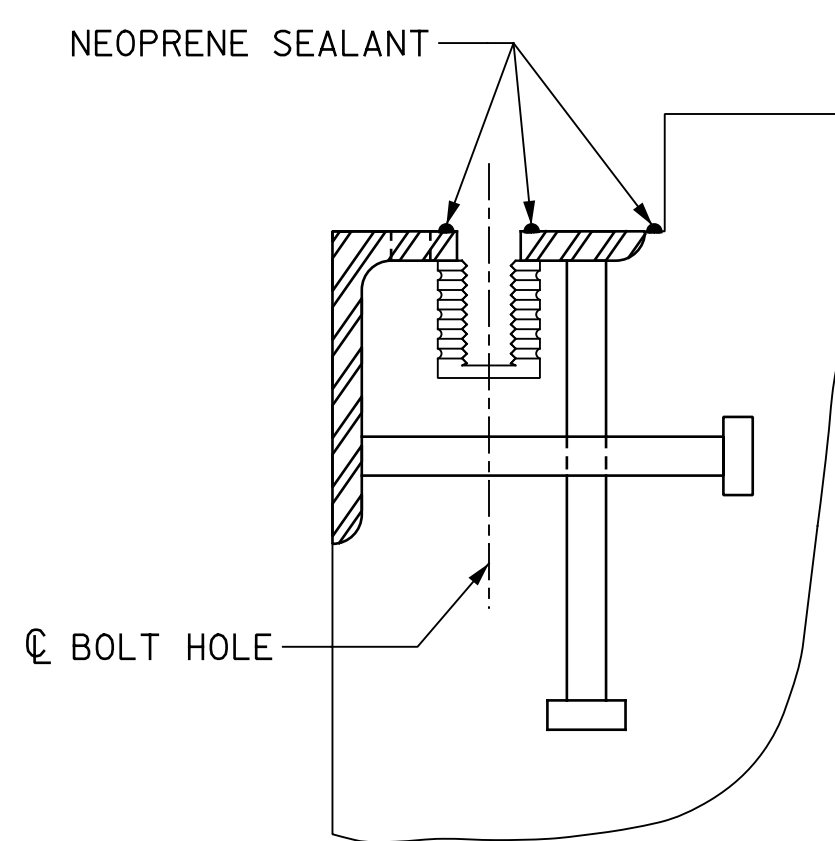

CROSS SECTION

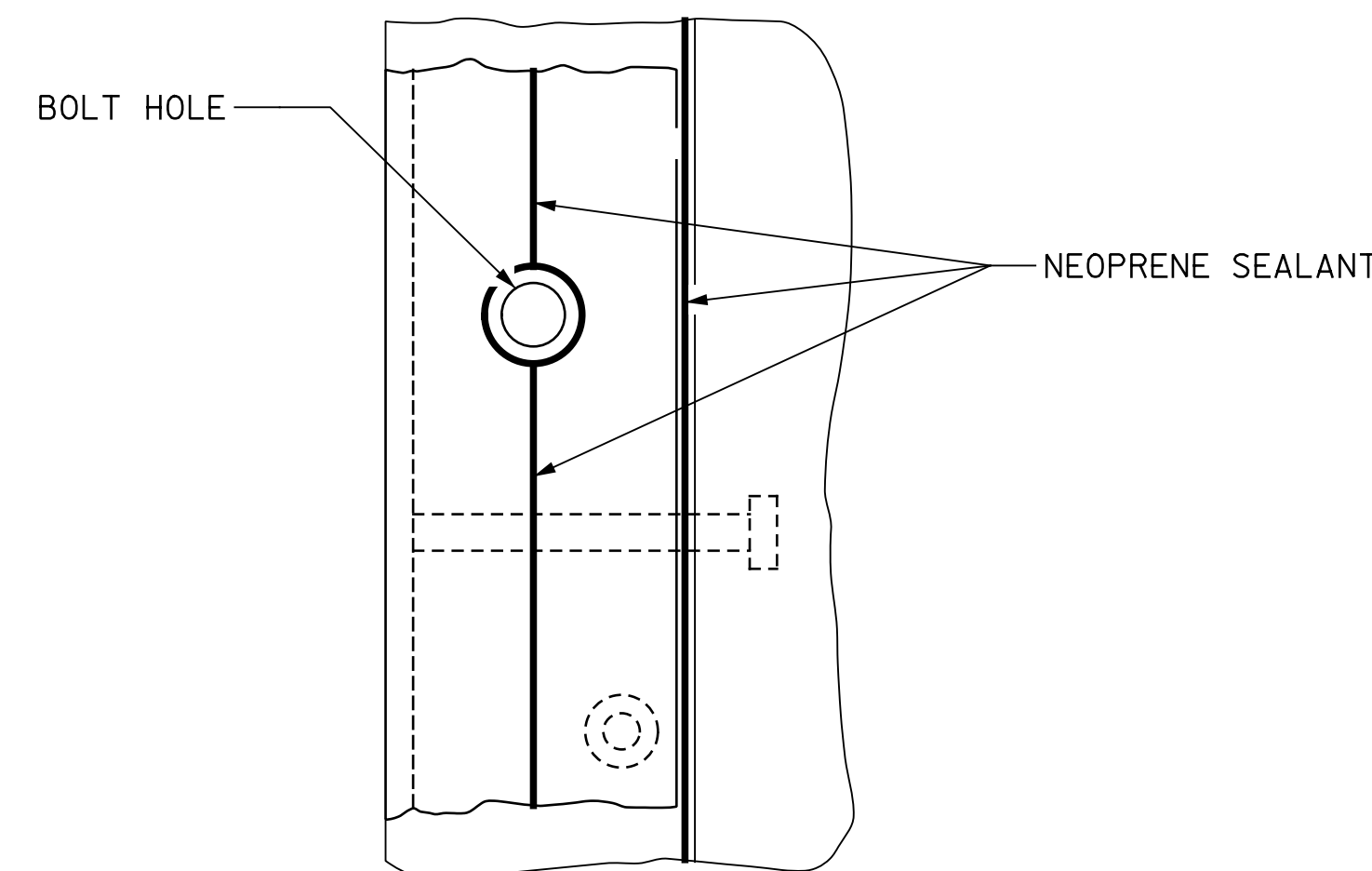

CROSS SECTION

INSTALLATION SKETCH

PROJECT NO. I-5955
GUILFORD COUNTY
 BRIDGE NO. 400348

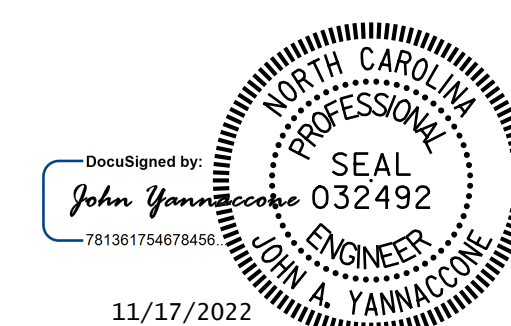

11/17/2022

STATE OF NORTH CAROLINA
 DEPARTMENT OF TRANSPORTATION
 RALEIGH

EXPANSION JOINT SEAL DETAILS

DRAWN BY : J. MYA DATE : 10/2022
 CHECKED BY : J. YANNACCONE DATE : 10/2022



DOCUMENT NOT CONSIDERED FINAL UNLESS ALL SIGNATURES COMPLETED

REVISIONS						SHEET NO. S9-7
NO.	BY:	DATE:	NO.	BY:	DATE:	
1			3			TOTAL SHEETS 127
2			4			