

Docusign Envelope ID: 5391C456-74E9-442A-9E05-6GF2E510744D
 I:\717\2022 9:55:47 AM pdf_color_gfclt_FS.plt I-5995.tbl
 p:\gfnct-pw\bentley.com:gfnct-pw-01\Documents\Projects\67945\5-Working\Task 010 - I-5955 Greensboro Rehab\Structures\CAD\2.0 100%\Plans\408_005_I-5955_SMU_TS_003_400340

NOTES:
 SEE TRAFFIC MANAGEMENT PLANS FOR LANE WIDTHS, SEQUENCING, AND OTHER TRAFFIC CONTROL MEASURES FOR STAGING OF OVERLAY SURFACE PREPARATION AND ASPHALT WEARING SURFACE (AWS) PLACEMENT.
 SEE ROADWAY PLANS FOR MILLING AND OVERLAY OF THE BRIDGE DECK.
 THE CONTRACTOR SHALL ENSURE THAT THE EXISTING DECK DRAINS ARE OPEN AND FULLY FUNCTIONAL AFTER PLACEMENT OF THE ASPHALT WEARING SURFACE.

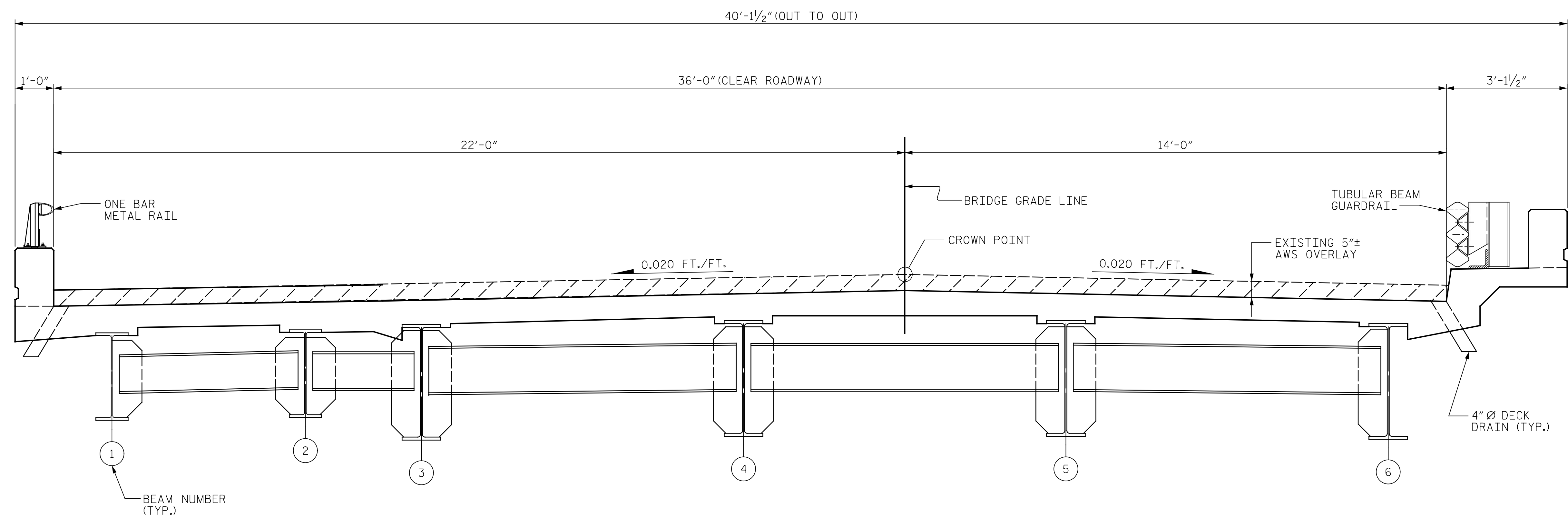

TYPICAL SECTION
(EXISTING)

PROJECT NO. I-5955
GUILFORD COUNTY
 BRIDGE NO. 400340



STATE OF NORTH CAROLINA
 DEPARTMENT OF TRANSPORTATION
 RALEIGH
TYPICAL SECTION AND SURFACE PREPARATION DETAILS

DRAWN BY : J. HARRIS DATE : 10/2022
 CHECKED BY : J. YANNACCONE DATE : 10/2022



DOCUMENT NOT CONSIDERED FINAL UNLESS ALL SIGNATURES COMPLETED

REVISIONS						SHEET NO.
NO.	BY:	DATE:	NO.	BY:	DATE:	
1			3			S8-3
2			4			TOTAL SHEETS 127