

p:\gfnnet-pw\benfley.com\gfnnet-pw-01\Documents\Projects\67945\5-Working\Task 010 - I-5955 Greensboro Rehab\Structures\CAD\2.0 100% Plans\405\_015\_I-5955\_SMU\_JT\_008\_400329  
 I-5955.tbl  
 I:\17\2022 9:53:43 AM pdf\_color\_gfclt\_FS.plt  
 DocuSign Envelope ID: 5391C456-74E9-442A-9E05-AGF2E510744D

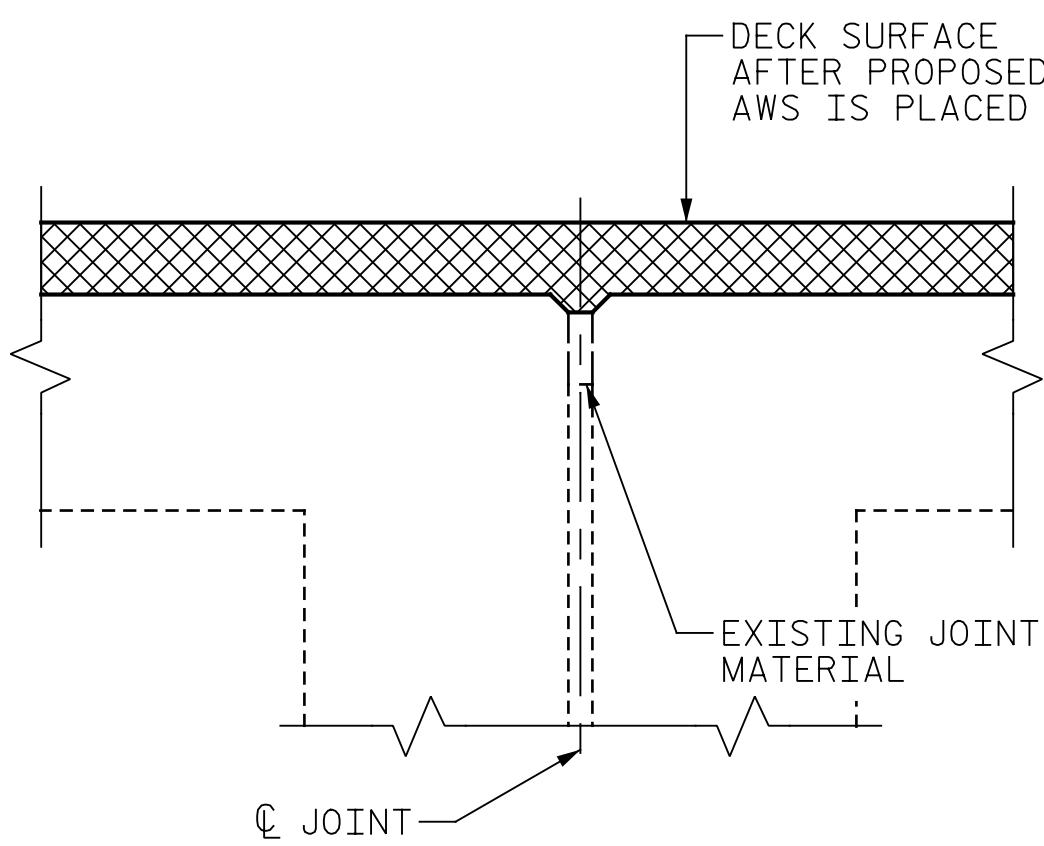

EXISTING JOINT AFTER AWS PLACEMENT

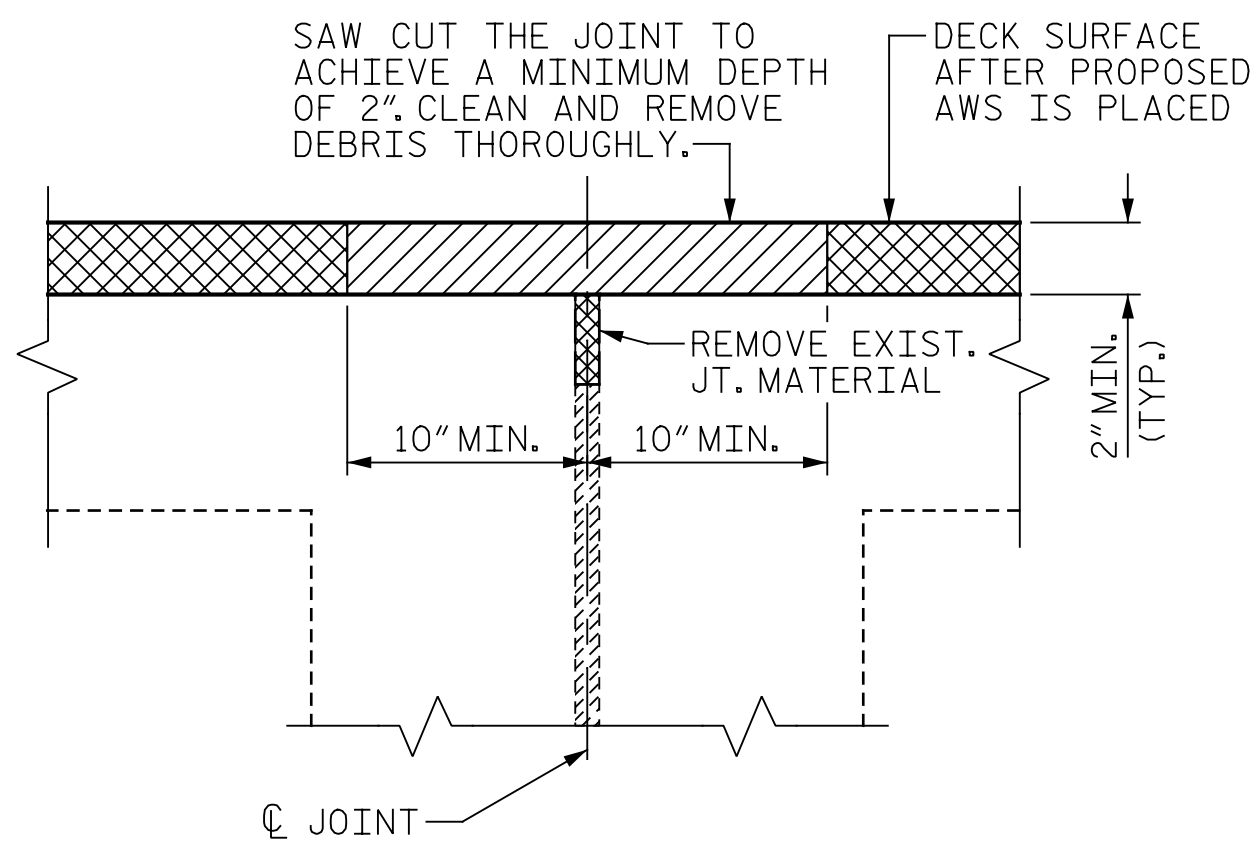

DEMOLITION PREPARATION

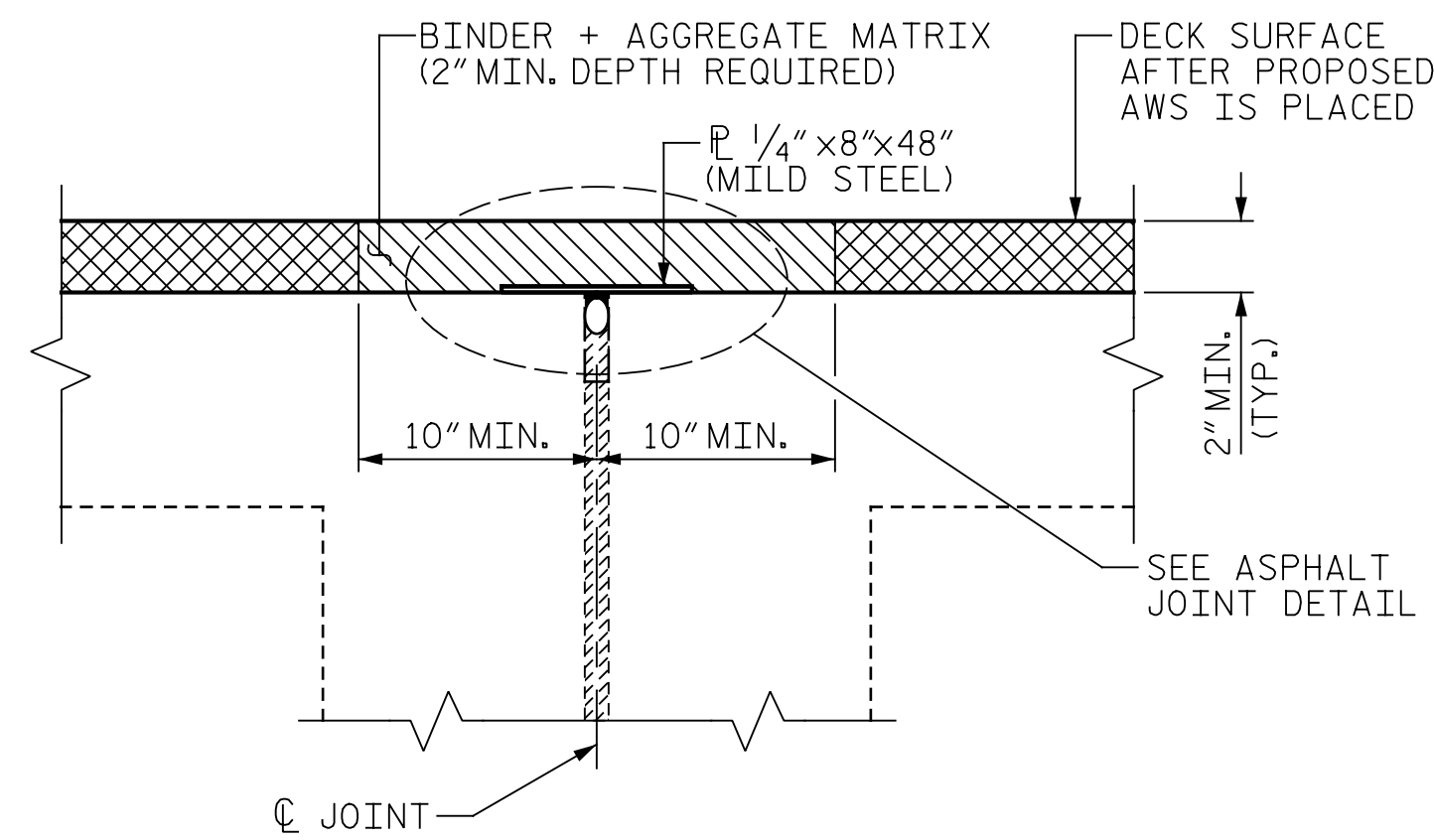

PROPOSED JOINT

SECTION G-G  
(TYP. AT BENTS)

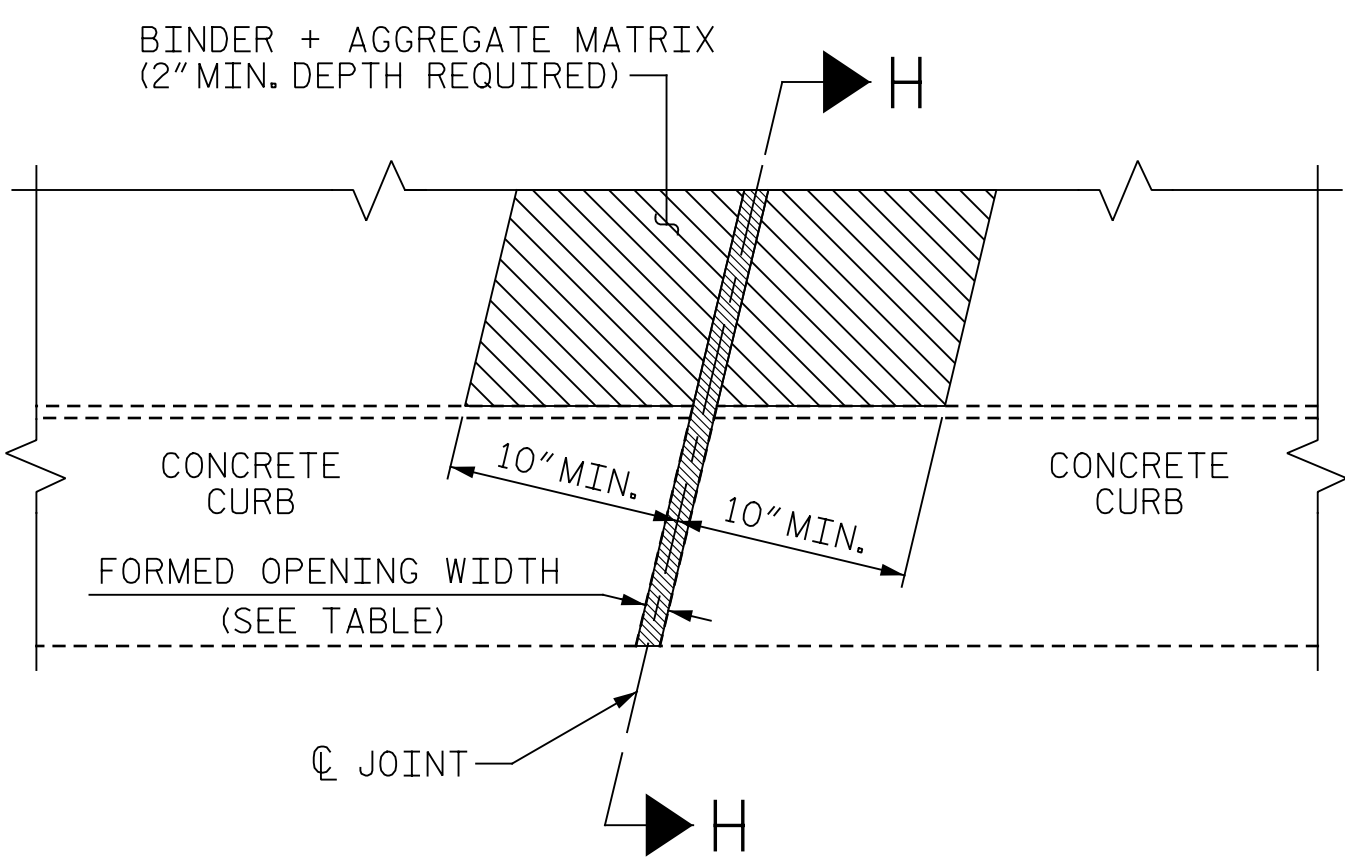

PLAN AT BARRIER

(PROPOSED JOINT SEAL, STEEL P NOT SHOWN FOR CLARITY)

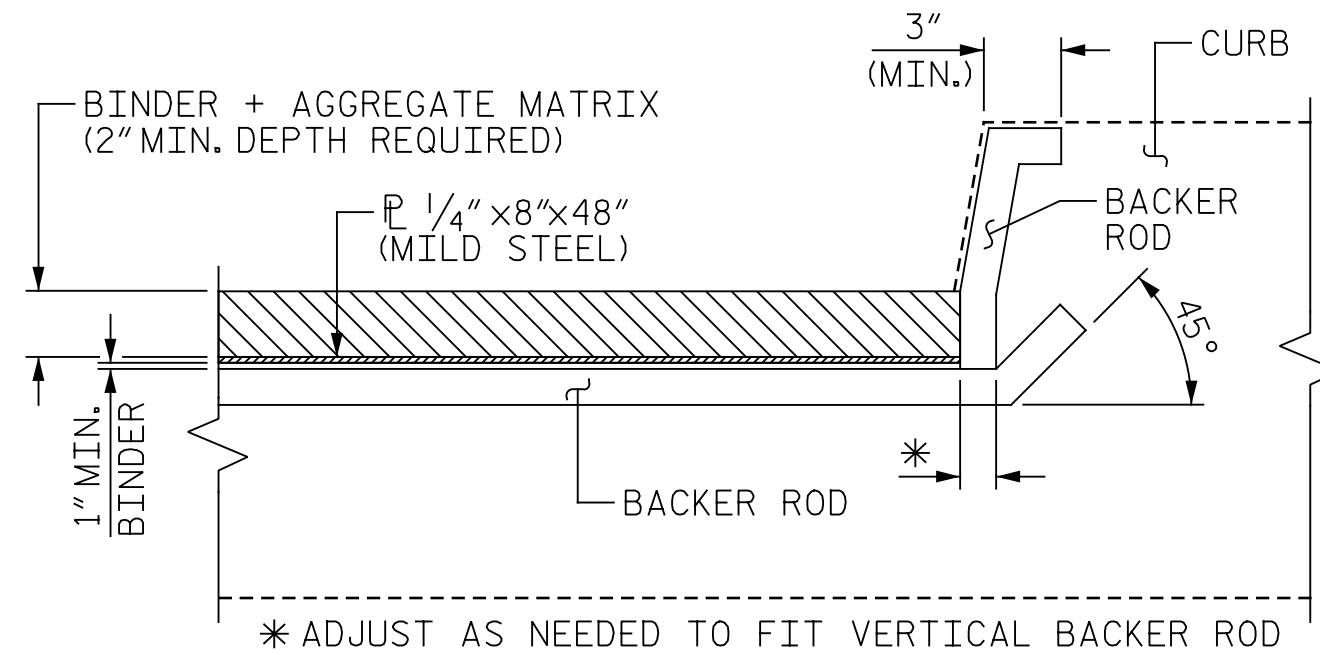

SECTION H-H  
(PROPOSED JOINT SEAL)

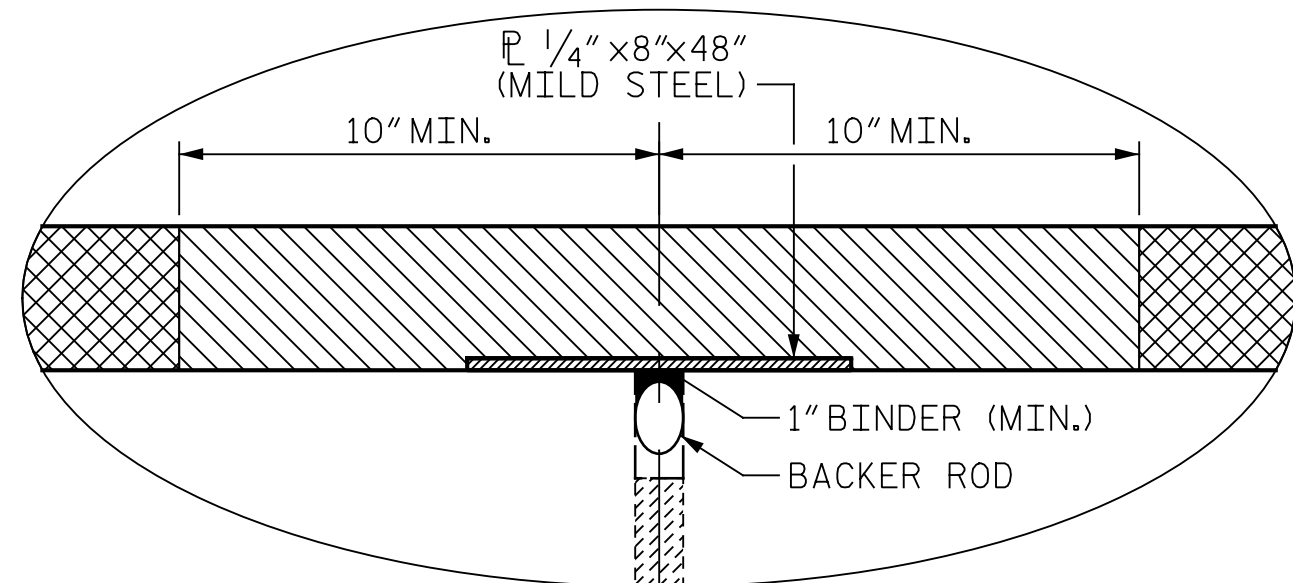

ASPHALT JOINT DETAIL

NOTES:

THE CONTRACTOR SHALL FIELD VERIFY THE EXISTING JOINT OPENING PRIOR TO ORDERING JOINT SEAL MATERIAL. IF THE ACTUAL OPENING VARIES FROM TO OPENING INDICATED IN THE DETAIL BY MORE THAN 1/4", NOTIFY THE ENGINEER. REVISION OF THE JOINT SEAL SIZE MIGHT BE NECESSARY.

THE CONTRACTOR SHALL TAKE CARE DURING JOINT REPAIR OPERATIONS NOT TO DROP ANY MATERIAL THAT FALLS BELOW THE BRIDGE WITHOUT PROTECTIVE DEVICES BELOW TO CATCH THE MATERIAL. ANY MATERIAL THAT FALLS BELOW THE BRIDGE SHALL BE CONTAINED, REMOVED AND DISPOSED OF BY THE CONTRACTOR AT NO EXTRA COST TO THE DEPARTMENT. IF THE ENGINEER DETERMINES THAT THE PROTECTIVE DEVICES ARE NOT ADEQUATE OR NOT BEING EMPLOYED, THE WORK SHALL BE SUSPENDED UNTIL ADEQUATE PROTECTION IS PROVIDED.

THE CONTRACTOR WILL NOT BE PERMITTED TO FORM THE JOINTS IN LIEU OF SAWING THE JOINT.

THE INSTALLED BACKER ROD AND SILICONE SEALANT SHALL BE WATER TIGHT.

FOR EXCAVATION BELOW THE BOTTOM OF THE PLANNED JOINT DECK DEMOLITION, CONCRETE FOR DECK REPAIRS SHALL BE PLACED IN THE EXCAVATED AREA TO THE ELEVATION AT BOTTOM OF THE PROPOSED ASPHALT JOINT DETAIL SHOWN.

DEMOLISH BRIDGE JOINT AREA SUCH THAT THE BOTTOM OF THE EXCAVATION SHALL BE REASONABLY FLAT AND LEVEL AND TO THE NECESSARY DEPTH, SUCH THAT ASPHALT JOINT SHALL BE FOUNDED ON CONCRETE OR REPAIR CONCRETE SUBSTRATE.

PRIOR TO ASPHALT JOINT REPAIR/REPLACEMENT, PERFORM DECK SURFACE REPAIR IN ACCORDANCE WITH "PLAN OF SPAN" SHEETS.

BACKER ROD SHALL BE INSTALLED AS PER MANUFACTURER'S RECOMMENDATIONS.

FOR ASPHALT PLUG JOINTS FOR PRESERVATION, SEE SPECIAL PROVISIONS.

FOR CONCRETE DECK REPAIR FOR ASPHALT OVERLAY, SEE SPECIAL PROVISIONS.

SEE ROADWAY PLANS FOR MILLING AND OVERLAY OF THE BRIDGE DECK.

LOCATION	ASPHALT PLUG JOINT FOR PRESERVATION (LIN. FT.)	FORMED OPENING WIDTH PER EXISTING BRIDGE PLANS	TOTAL THEORETICAL MOVEMENT PERPENDICULAR TO THE JOINT
BENT 1	31.0	1"	1/2"
BENT 2	31.0	1"	5/8"
BENT 3	31.0	1 1/4"	15/16"

PROJECT NO. I-5955  
GUILFORD COUNTY  
 BRIDGE NO. 400329

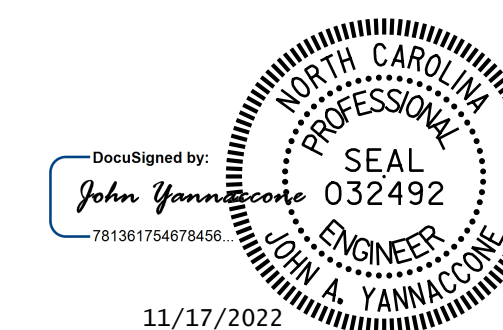

STATE OF NORTH CAROLINA  
 DEPARTMENT OF TRANSPORTATION  
 RALEIGH

ASPHALT PLUG JOINT DETAILS

DRAWN BY: J. HARRIS DATE: 10/2022  
 CHECKED BY: J. YANNAKONE DATE: 10/2022



DOCUMENT NOT CONSIDERED FINAL UNLESS ALL SIGNATURES COMPLETED

REVISIONS						SHEET NO.
NO.	BY:	DATE:	NO.	BY:	DATE:	
1			3			S5-8
2			4			TOTAL SHEETS 127