

p:\gfn\gfnet-pw-bentley.com\gfnet-pw-01\Documents\Projects\67945\5-Work\King\Task\_010 - I-5955 Greensboro Rehab\Structures\CAD\2.0 100% Plans\401\_005.I-5955\_SMU\_TS\_003\_400285  
 I:\17\2022 9:45:29 AM pdf\_color\_gfclt\_FS.plt I-5955.tbl

**NOTES:**  
 SEE TRAFFIC MANAGEMENT PLANS FOR LANE WIDTHS, SEQUENCING, AND OTHER TRAFFIC CONTROL MEASURES FOR STAGING OF ASPHALT WEARING SURFACE (AWS) PLACEMENT.  
 SEE ROADWAY PLANS FOR MILLING AND OVERLAY OF THE BRIDGE DECK.  
 THE CONTRACTOR SHALL ENSURE THAT THE EXISTING DECK DRAINS ARE OPEN AND FULLY FUNCTIONAL AFTER PLACEMENT OF THE ASPHALT WEARING SURFACE.

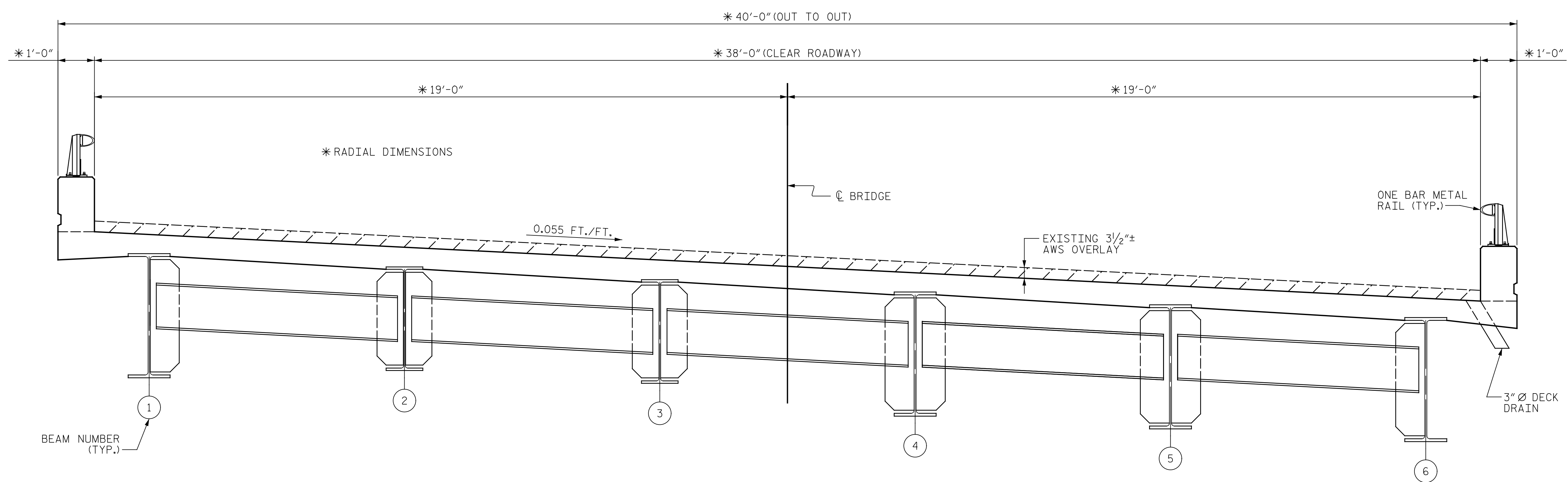

BEAM NUMBER (TYP.)

HALF SECTION  
(SPAN A & C)

HALF SECTION  
(SPAN B)

TYPICAL SECTION  
(EXISTING)

PROJECT NO. I-5955  
GUILFORD COUNTY  
 BRIDGE NO. 400285

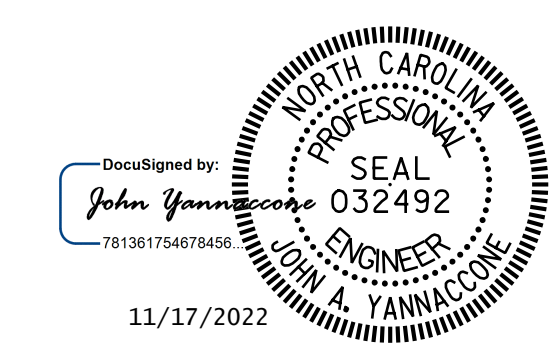

STATE OF NORTH CAROLINA  
 DEPARTMENT OF TRANSPORTATION  
 RALEIGH  
**TYPICAL SECTION AND  
 SURFACE PREPARATION  
 DETAILS**

DRAWN BY : J. HARRIS DATE : 10/2022  
 CHECKED BY : J. YANNACCONE DATE : 10/2022



DOCUMENT NOT CONSIDERED  
 FINAL UNLESS ALL  
 SIGNATURES COMPLETED

REVISIONS						SHEET NO.
NO.	BY:	DATE:	NO.	BY:	DATE:	TOTAL SHEETS
1			3			S1-3
2			4			127