

DETAIL - GORE AREAS

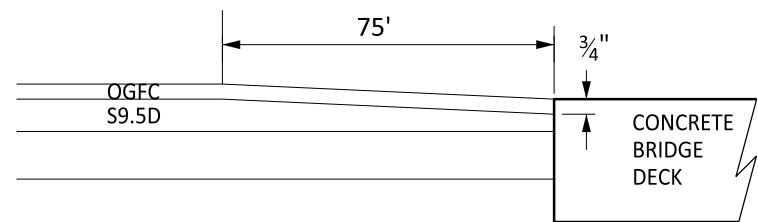

**INCIDENTAL MILLING PAVEMENT
DETAIL AT CONCRETE BRIDGES**

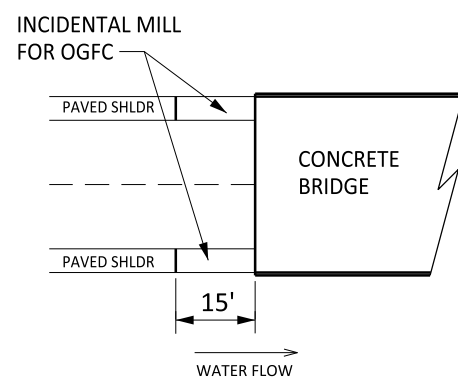

MILLING DETAIL 1

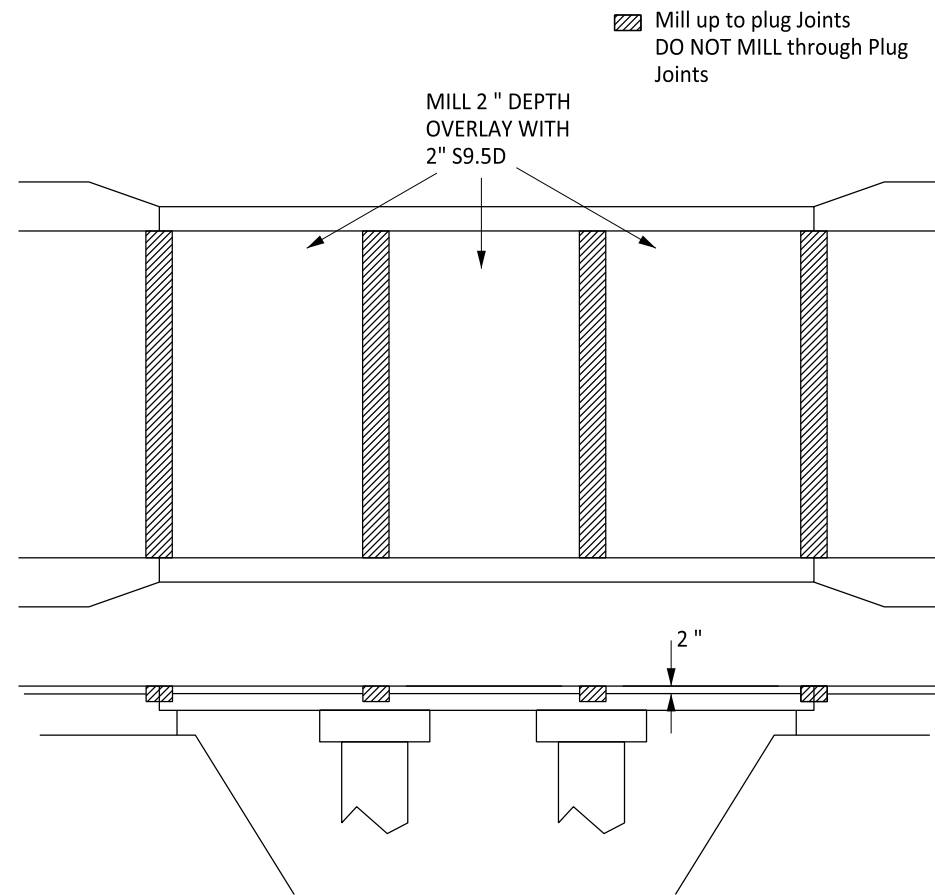

ASPHALT BRIDGE MILLING

NOTE

1. All milling, S9.5D and OGFC must be completed before plug joint work can begin.
2. OGFC may be placed directly over existing plug joints.
3. Refer to the structure plans and contract special provisions for any necessary bridge deck repairs encountered after milling the AWS, and before placing the new AWS, on Bridges 285, 299, 339 and 340.