

**PART SECTION AT INTERMEDIATE DIAPHRAGM**  
(63" BULB TEE GIRDER SHOWN)

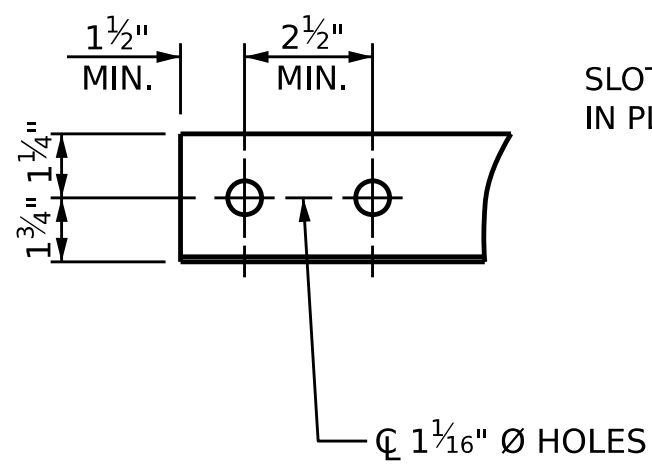

**ANGLE END**  
(L 3 X 3 X 5/16)

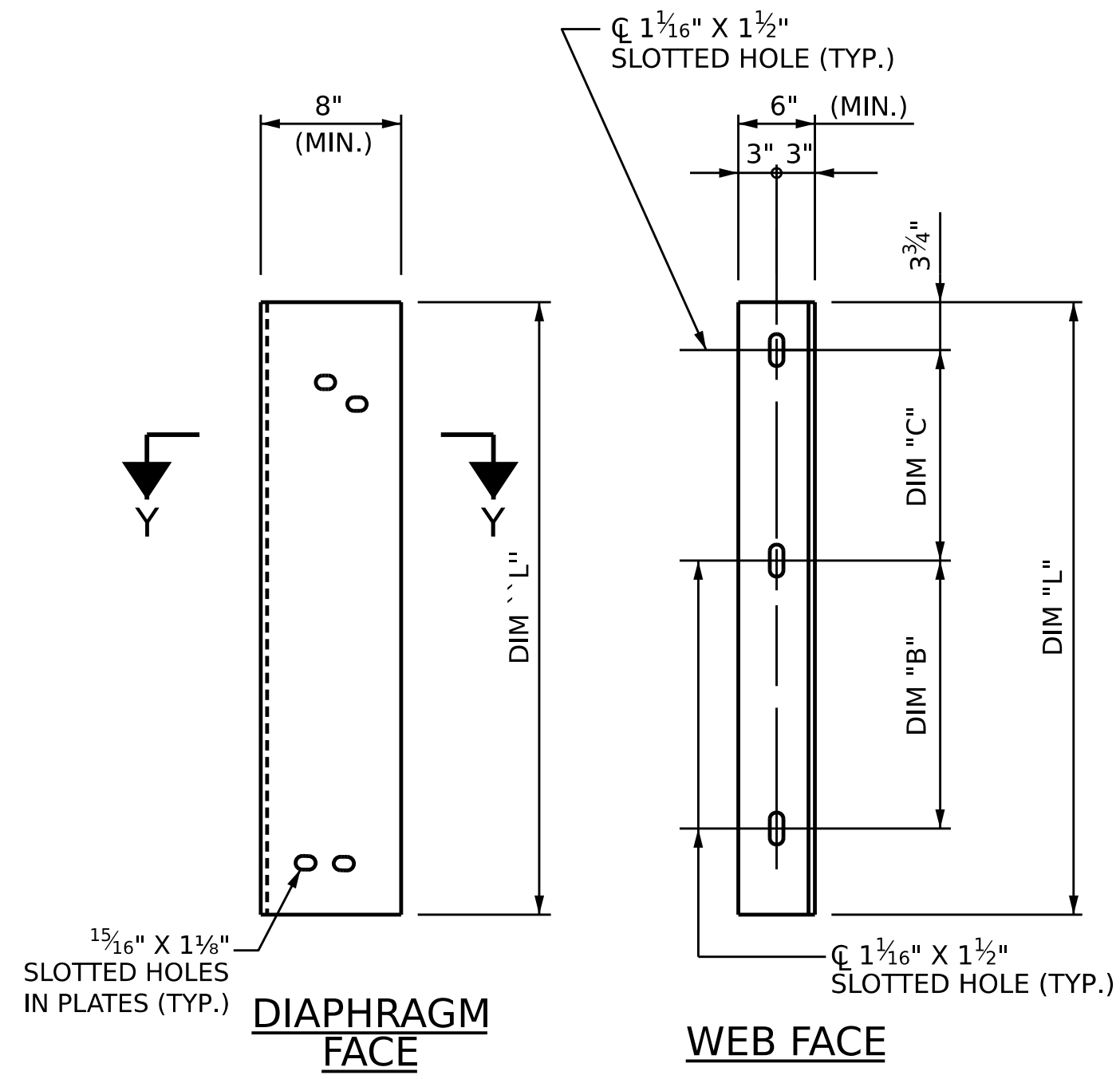

**CONNECTOR PLATE DETAIL**

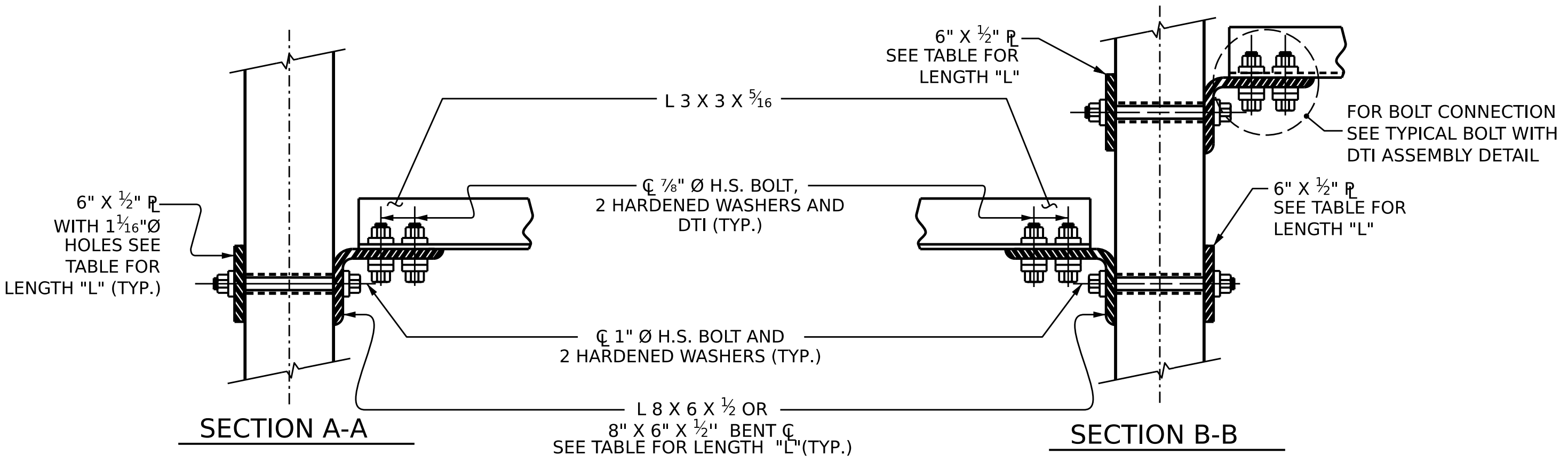

**CONNECTION DETAILS**

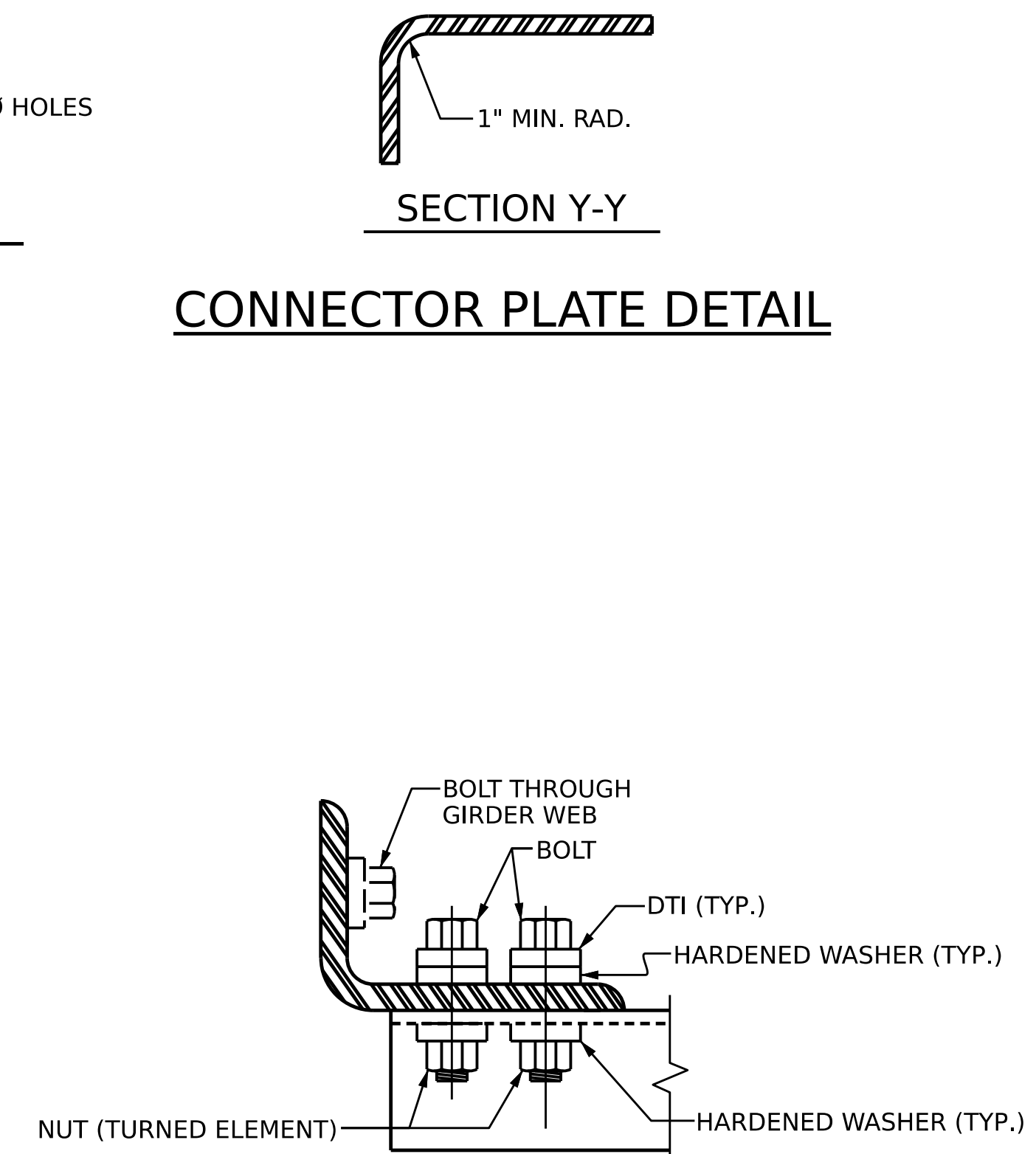

**BOLT WITH DTI ASSEMBLY DETAIL**

**STRUCTURAL STEEL NOTES**

ALL INTERMEDIATE DIAPHRAGM STEEL AND CONNECTOR PLATES SHALL BE AASHTO M270 GRADE 50 OR APPROVED EQUAL.

TENSION ON THE ASTM A325 BOLTS THROUGH THE ANGLE MEMBER SHALL BE CALIBRATED USING DIRECT TENSION INDICATOR WASHERS IN ACCORDANCE WITH THE STANDARD SPECIFICATIONS.

TENSION ON THE ASTM A449 BOLTS THROUGH THE GIRDER WEB SHALL BE SNUG TIGHTENED FOLLOWED BY AN ADDITIONAL 1/4 TURN.

THE PLATES, BENT PLATES, AND ANGLES SHALL BE GALVANIZED OR METALLIZED IN ACCORDANCE WITH THE STANDARD SPECIFICATIONS. FOR THERMAL SPRAYED COATINGS (METALLIZATION), SEE SPECIAL PROVISIONS.

FOR METALLIZATION, APPLY A THERMAL SPRAYED COATING WITH A SEAL COAT TO ALL STEEL DIAPHRAGM SURFACES IN ACCORDANCE WITH THE DEPARTMENT'S THERMAL SPRAYED COATINGS (METALLIZATION) PROGRAM, THERMAL SPRAYED COATINGS SPECIAL PROVISION AND SECTION 442 OF THE STANDARD SPECIFICATIONS.

GALVANIZE THE HIGH STRENGTH BOLTS, NUTS, WASHERS AND DIRECT TENSION INDICATORS IN ACCORDANCE WITH THE STANDARD SPECIFICATIONS.

USE AN ASTM F436 HARDENED WASHER WITH STANDARD AND SLOTTED HOLES UNDER EACH BOLT HEAD AND NUT.

FOR BOLTS THROUGH THE GIRDER WEB, PROVIDE SUFFICIENT LENGTH OF THREADS ON ALL BOLTS TO ACCOMMODATE WASHERS AND THE THICKNESS OF CONNECTING MEMBER PLUS AT LEAST 1/4" PROJECTION BEYOND THE NUT.

INTERMEDIATE DIAPHRAGM ASSEMBLY SHALL COMPLY WITH SECTION 1072 OF THE STANDARD SPECIFICATIONS.

SUBMIT TWO SETS OF WORKING DRAWINGS FOR THE INTERMEDIATE DIAPHRAGM ASSEMBLY FOR REVIEW, COMMENTS AND ACCEPTANCE. AFTER REVIEW, COMMENTS, AND ACCEPTANCE, SUBMIT SEVEN SETS FOR DISTRIBUTION.

IN THE EXTERIOR BAYS, PLACE TEMPORARY STRUTS BETWEEN PRESTRESSED GIRDERS ADJACENT TO THE STEEL DIAPHRAGMS. STRUTS SHALL REMAIN IN PLACE 3 DAYS AFTER CONCRETE IS PLACED.

THE COST OF THE STEEL DIAPHRAGMS AND ASSEMBLIES SHALL BE INCLUDED IN THE UNIT PRICE BID FOR PRESTRESSED CONCRETE GIRDERS.

**TABLE**

| GIRDER TYPE  | DIM "A" | DIM "B" | DIM "C" | DIM "L" |
|--------------|---------|---------|---------|---------|
| 63" BULB TEE | 1'-5"   | 1'-4"   | 1'-4"   | 3'-5"   |

PROJECT NO. BR-0094  
ROCKINGHAM COUNTY  
 STATION: 20+38.70 -L-



STATE OF NORTH CAROLINA  
 DEPARTMENT OF TRANSPORTATION  
 RALEIGH  
**STANDARD**  
**INTERMEDIATE**  
**STEEL DIAPHRAGMS FOR**  
**63" MODIFIED BULB TEE**  
**PRESTRESSED CONCRETE**  
**GIRDERS**

ASSEMBLED BY : O. T. NGUYEN DATE: 08/2022  
 CHECKED BY : F. LEA DATE: 09/2022  
 DRAWN BY : RWW 11/09 REV. 10/1/11 MAA/GM  
 CHECKED BY : GM 11/09 REV. 12/17 MAA/THC

| NO | REVISIONS |       |    | SHEET NO.       |
|----|-----------|-------|----|-----------------|
|    | BY:       | DATE: | NO |                 |
| 1  |           |       | 3  | S-14            |
| 2  |           |       | 4  | TOTAL SHEETS 30 |

DOCUMENT NOT CONSIDERED FINAL UNLESS ALL SIGNATURES COMPLETED