

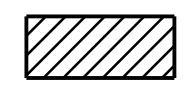

CLEARING AND GRUBBING EROSION CONTROL FOR CONSTRUCTION SHEET 4

NOTE: UTILIZE TEMPORARY SEDIMENT BASIN OR SPECIAL STILLING BASIN(S) AS STILLING BASIN WHERE APPLICABLE.

NOTE: PLACE TEMPORARY ROCK SEDIMENT DAMS TYPE - B AND TEMPORARY ROCK SILT CHECKS TYPE - A AT DRAINAGE OUTLETS.

NOTE: UTILIZE COIR FIBER MATTING ADJACENT TO WETLANDS/JURISDICTIONAL AREAS, AND AS DIRECTED

 ENVIRONMENTALLY SENSITIVE AREA SEE PROJECT SPECIAL PROVISIONS

 INCLUDED CLEARING AND GRUBBING FOR DETOUR BRIDGE

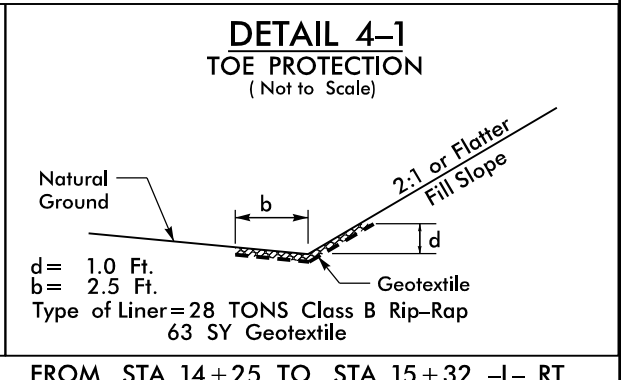
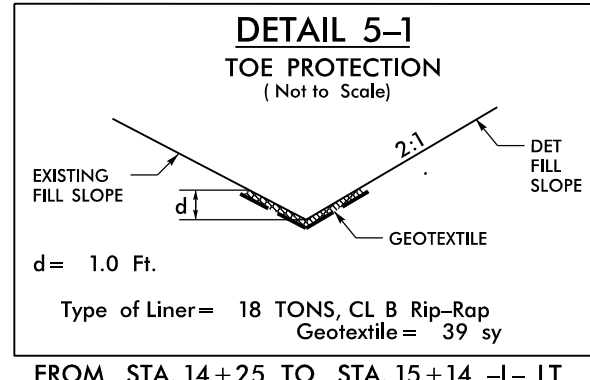
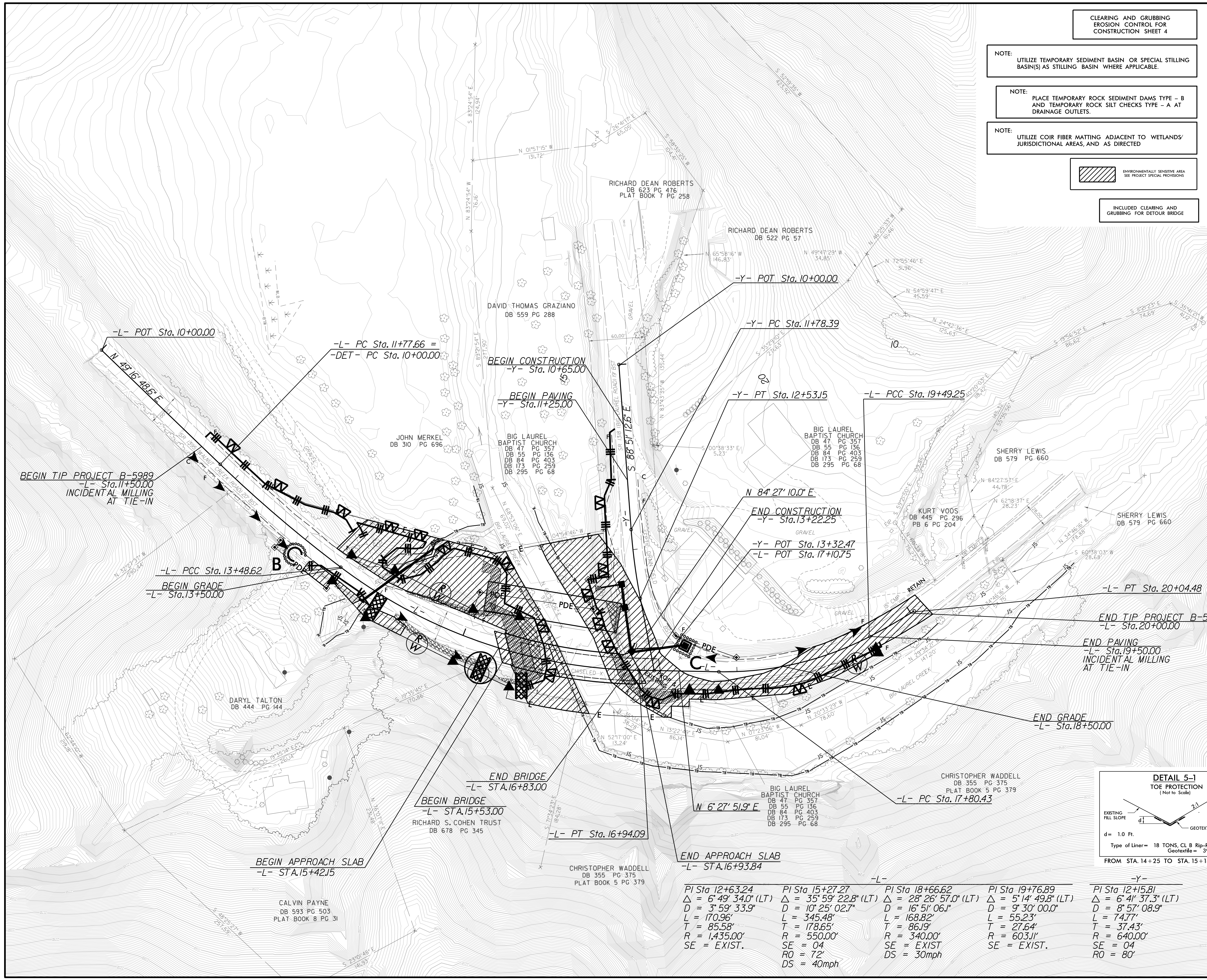
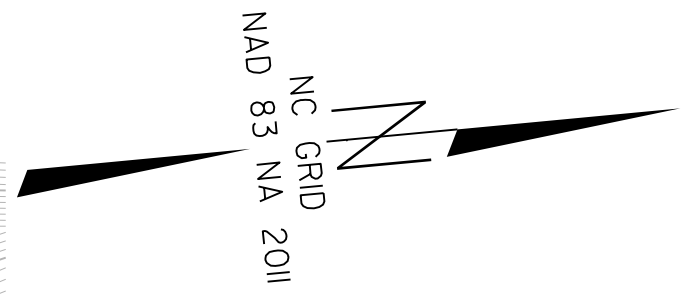

PI Sta	Δ	D	L	T	R	SE	RO
12+63.24	6° 49' 34.0" (LT)	3' 59' 33.9"	170.96'	85.58'	1,435.00'	EXIST.	
15+27.27	35° 59' 22.8" (LT)	10' 25' 02.7"	345.48'	178.65'	550.00'	04	72'
18+66.62	28° 26' 57.0" (LT)	16' 51' 06.1"	168.82'	86.19'	340.00'	EXIST.	30mph
19+76.89	5° 14' 49.8" (LT)	9' 30' 00.0"	55.23'	27.64'	603.11'	EXIST.	
12+15.81	6° 41' 37.3" (LT)	8' 57' 08.9"	74.77'	37.43'	640.00'	04	80'