

**This electronic collection of documents is provided
for the convenience of the user
and is Not a Certified Document –**

**The documents contained herein were originally issued
and sealed by the individuals whose names and license
numbers appear on each page, on the dates appearing
with their signature on that page.**

**This file or an individual page
shall not be considered a certified document.**

STATE OF NORTH CAROLINA
DIVISION OF HIGHWAYS

TRANSPORTATION MANAGEMENT PLAN

CUMBERLAND COUNTY

DIVISION 6

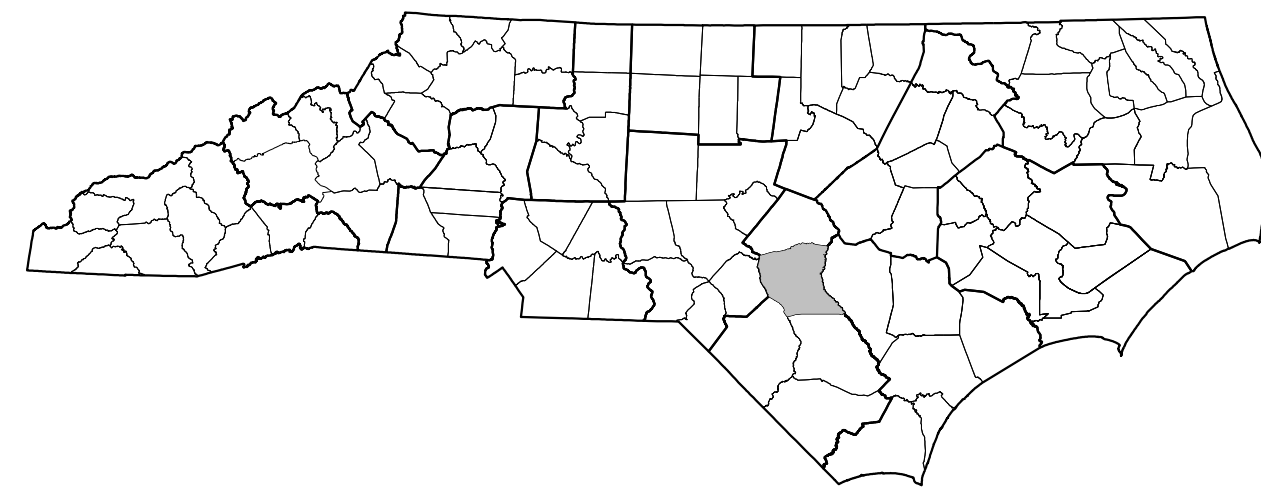

LOCATION: BRIDGES 250326, 250327, 250352, AND 250362

TYPE OF WORK: BRIDGE PRESERVATION - SHOTBLASTING AND SILANE DECK TREATMENT

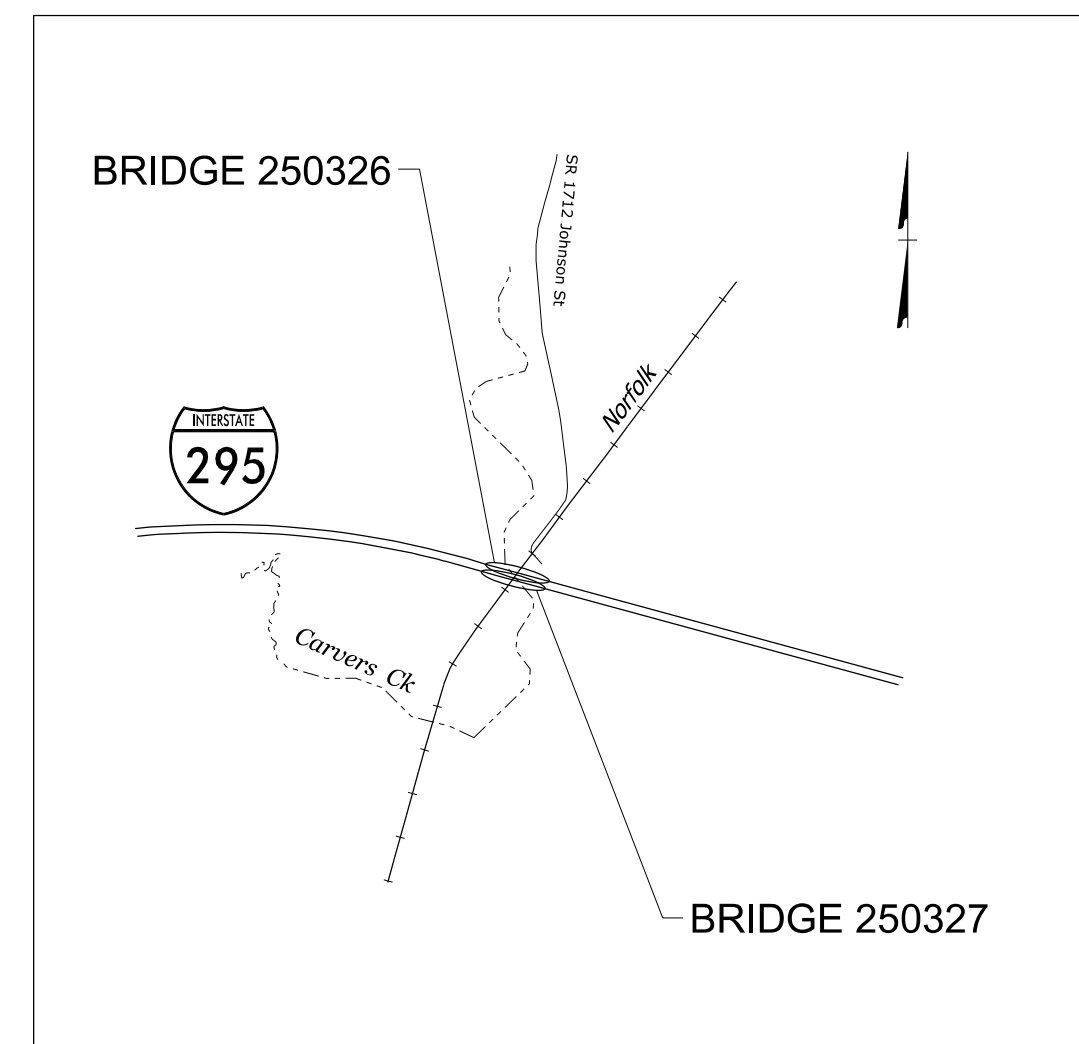
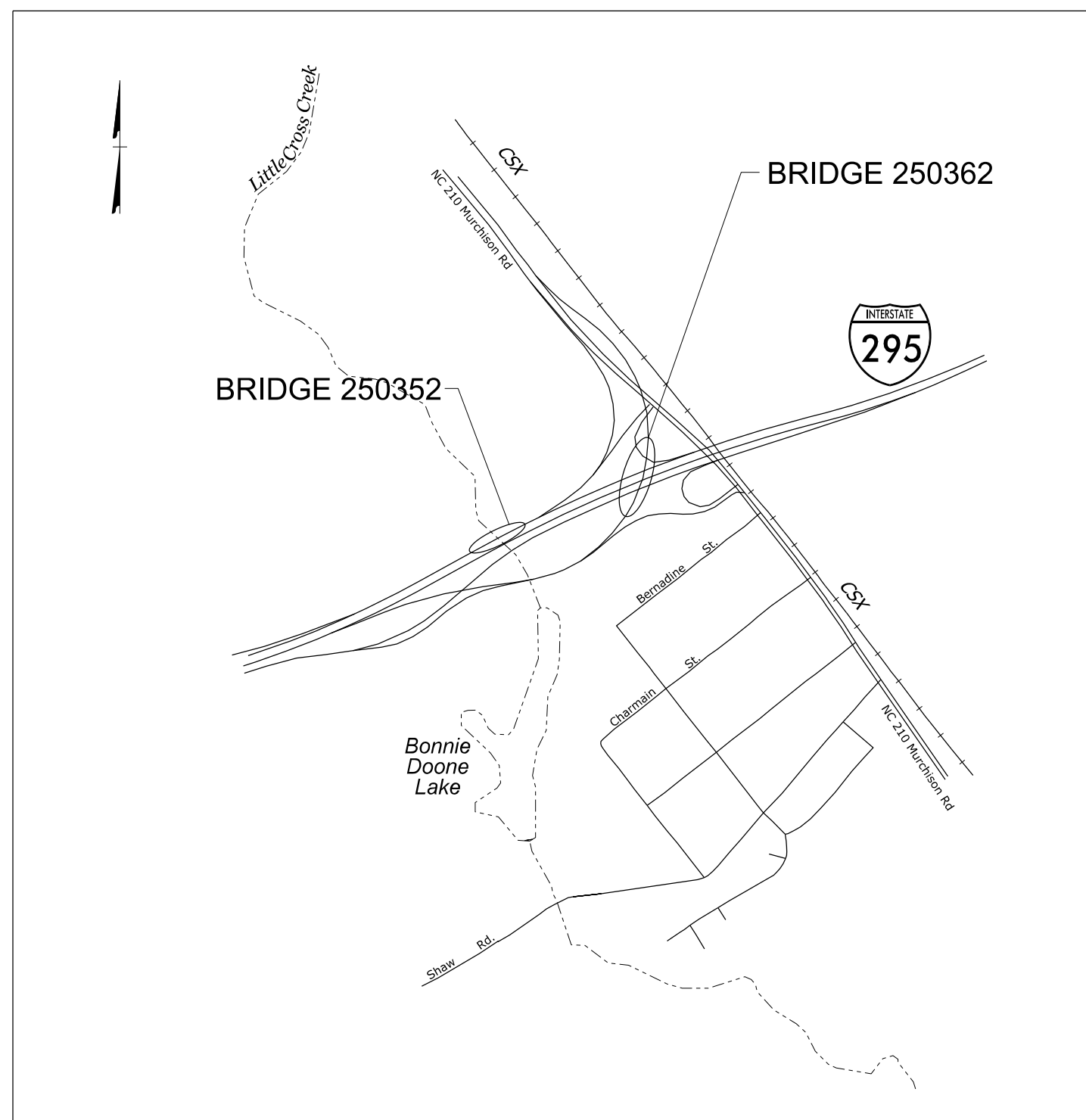

INDEX OF SHEETS

SHEET NO.	TITLE
TMP-1	TITLE SHEET, VICINITY MAP, AND INDEX OF SHEETS
TMP-1A	LIST OF APPLICABLE ROADWAY STANDARD DRAWINGS, AND LEGEND
TMP-2	GENERAL NOTES
TMP-3	TEMPORARY TRAFFIC CONTROL PHASING
TMP-4	BRIDGE 250326
TMP-5 THRU TMP-10	BRIDGE 250327
TMP-11 THRU TMP-14	BRIDGE 250352
TMP-15 THRU TMP-18	BRIDGE 250362

10/20/2022 U:\Traffic\Transportation Management Plan\TCP\PLAN SHEETS\15BPR.58-TMP_01-TITLE.dgn dorichardson

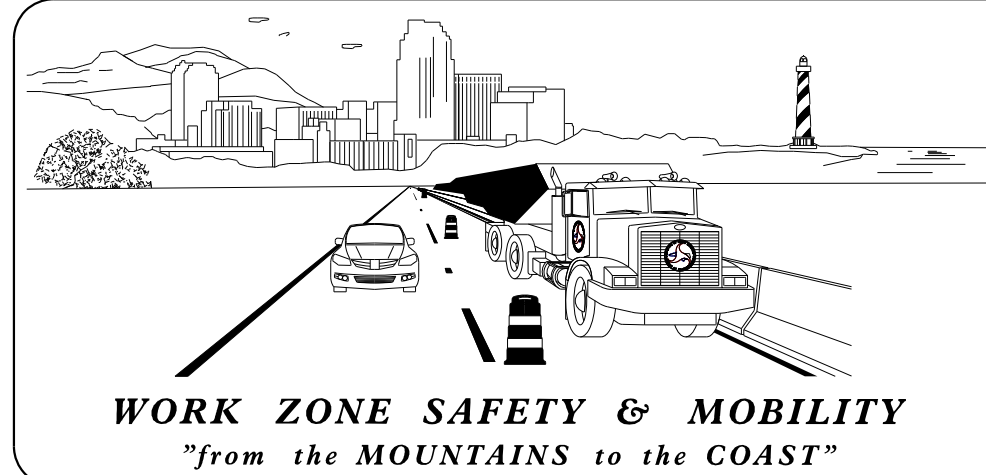

PLANS PREPARED BY:
 JAY W. WOOLARD, PE
 SENIOR TRANSPORTATION ENGINEER
 DONALD RICHARDSON
 SENIOR TRANSPORTATION DESIGNER

NCDOT CONTACTS:
 TIM SHERRILL, PE
 STRUCTURE MANAGEMENT UNIT

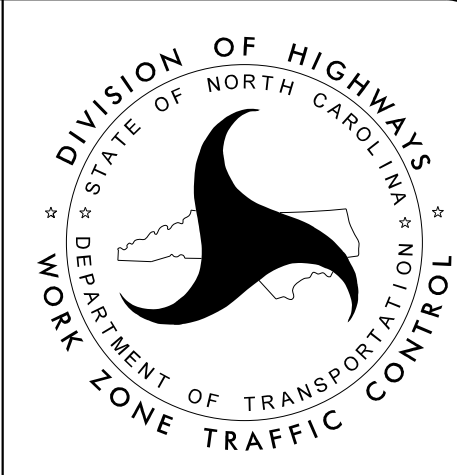

Stantec Consulting Services Inc.
 801 Jones Franklin Road, Suite 300
 Raleigh, NC 27606
 Tel. 919.851.6866
 Fax. 919.851.7024
 www.stantec.com
 License No. F-0672

**DOCUMENT NOT CONSIDERED FINAL
UNLESS ALL SIGNATURES COMPLETED**

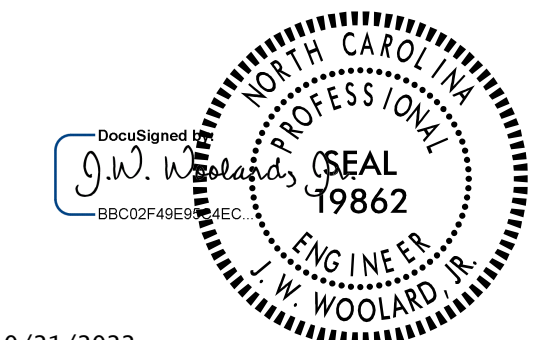

10/21/2022

TIP PROJECT: 15BPR.58

ROADWAY STANDARD DRAWINGS

THE FOLLOWING ROADWAY STANDARDS AS APPEAR IN "ROADWAY STANDARD DRAWINGS" - PROJECT SERVICES UNIT - N.C. DEPARTMENT OF TRANSPORTATION - RALEIGH, N.C., DATED JANUARY 2018 ARE APPLICABLE TO THIS PROJECT AND BY REFERENCE HEREBY ARE CONSIDERED A PART OF THESE PLANS:

STD. NO.	TITLE
1101.01	WORK ZONE ADVANCE WARNING SIGNS
1101.02	TEMPORARY LANE CLOSURES
1101.11	TRAFFIC CONTROL DESIGN TABLES
1110.02	PORTABLE WORK ZONE SIGNS
1115.01	FLASHING ARROW BOARDS
1130.01	DRUMS
1165.01	TRUCK MOUNTED ATTENUATOR
1180.01	SKINNY - DRUM

LEGEND

GENERAL

- DIRECTION OF TRAFFIC FLOW
- EXIST. PVMT.
- PROPOSED PVMT.
- NORTH ARROW
- TEMP. SHORING (LOCATION PURPOSES ONLY)
- WORK AREA
- PREVIOUSLY STARTED / CONCURRENT CONSTRUCTION
- PAVEMENT REMOVAL
- TEMPORARY PAVEMENT
- TEMPORARY PAVEMENT ASPHALT PAD
- TEMPORARY PAVEMENT BREAKDOWN LANE

PAVEMENT MARKINGS

- | | |
|--|---------------------|
| | EXISTING LINES |
| | TEMPORARY MARKINGS |
| | PREVIOUSLY PLACED |
| | WHITE EDGE LINE |
| | YELLOW EDGE LINE |
| | BROKEN LANE LINES |
| | MINISKIP LANE LINES |
| | DOUBLE YELLOW LINES |
| | GORELINE |
| | STOP BAR |

PAVEMENT MARKING SYMBOLS

- EXISTING PAVEMENT MARKING SYMBOLS (HOLLOW)
- TEMPORARY SYMBOLS
- PREVIOUSLY PLACED
- PAVEMENT MARKING SYMBOLS
- ONLY PAVEMENT MARKING ALPHANUMERIC CHARACTERS

TRAFFIC CONTROL DEVICES

- | TEMPORARY DEVICES | PREVIOUSLY PLACED | |
|-------------------|-------------------|-----------------------------------|
| | | BARRICADE (TYPE III) |
| | | CONE |
| | | DRUM |
| | | FLASHING ARROW BOARD |
| | | FLAGGER |
| | | LAW ENFORCEMENT |
| | | TRUCK MOUNTED ATTENUATOR (TMA) |
| | | CHANGEABLE MESSAGE SIGN |
| | | TEMPORARY CRASH CUSHION |
| | | TEMPORARY CRASH CUSHION RESET |
| | | PORTABLE CONCRETE BARRIER |
| | | PORTABLE CONCRETE BARRIER (RESET) |
| | | ANCHORED CONCRETE BARRIER |
| | | ANCHORED CONCRETE BARRIER (RESET) |

SIGNALS

- | | | | | | |
|--|----------|--|----------|--|-----------|
| | EXISTING | | PROPOSED | | TEMPORARY |
|--|----------|--|----------|--|-----------|

TEMPORARY SIGNING

- | TEMPORARY SIGNS | PREVIOUSLY PLACED | |
|-----------------|-------------------|-----------------------------|
| | | PORTABLE SIGN |
| | | STATIONARY SIGN |
| | | STATIONARY OR PORTABLE SIGN |

PAVEMENT MARKERS

- CRYSTAL/CRYSTAL
- CRYSTAL/RED
- YELLOW/YELLOW

10/20/2022
 U:\Traffic\Transportation Management\Plan\TCP\PLAN SHEETS\15BPR.58-TMP_01A-RDWYSTDSLEGEND.dgn
 dorichardson

Stantec Consulting Services Inc.
 801 Jones Franklin Road
 Suite 300
 Raleigh, NC 27606
 Tel. 919.851.6866
 Fax. 919.851.7024
 www.stantec.com
 License No. F-0672

10/21/2022

DOCUMENT NOT CONSIDERED FINAL
 UNLESS ALL SIGNATURES COMPLETED

ROADWAY STANDARD
 DRAWINGS,
 AND LEGEND

GENERAL NOTES

PROJ. REFERENCE NO.	SHEET NO.
15.BPR.58	TMP-2

CHANGES MAY BE REQUIRED WHEN PHYSICAL DIMENSIONS IN THE DETAIL DRAWINGS, STANDARD DETAILS, AND ROADWAY DETAILS ARE NOT ATTAINABLE TO MEET FIELD CONDITIONS OR RESULT IN DUPLICATE OR UNDESIRE OVERLAPPING OF DEVICES. MODIFICATION MAY INCLUDE: MOVING, SUPPLEMENTING, COVERING, OR REMOVAL OF DEVICES AS DIRECTED BY THE ENGINEER.

THE FOLLOWING GENERAL NOTES APPLY AT ALL TIMES FOR THE DURATION OF THE CONSTRUCTION PROJECT EXCEPT WHEN OTHERWISE NOTED IN THE PLAN OR DIRECTED BY THE ENGINEER.

TIME RESTRICTIONS

A) DO NOT CLOSE OR NARROW TRAVEL LANES AS FOLLOWS:

ROAD NAME	DAY AND TIME RESTRICTIONS
ALL ROADS	6:00 A.M.-7:00 P.M. MONDAY THRU FRIDAY

B) DO NOT CLOSE OR NARROW TRAVEL LANES DURING HOLIDAYS AND SPECIAL EVENTS AS FOLLOWS:

- | ROAD NAME | HOLIDAY |
|-----------|---|
| ALL ROADS | |
| 1) | FOR ANY UNEXPECTED OCCURRENCE THAT CREATES UNUSUALLY HIGH TRAFFIC VOLUMES, AS DIRECTED BY THE ENGINEER. |
| 2) | FOR NEW YEAR'S, BETWEEN THE HOURS OF 6:00 A.M. DECEMBER 31ST TO 7:00 P.M. JANUARY 2ND. IF NEW YEAR'S DAY IS ON A FRIDAY, SATURDAY, SUNDAY, OR MONDAY THEN UNTIL 7:00 P.M. THE FOLLOWING TUESDAY. |
| 3) | FOR EASTER, BETWEEN THE HOURS OF 6:00 A.M. THURSDAY AND 7:00 P.M. MONDAY. |
| 4) | FOR MEMORIAL DAY, BETWEEN THE HOURS OF 6:00 A.M. FRIDAY TO 7:00 P.M. TUESDAY. |
| 5) | FOR INDEPENDENCE DAY, BETWEEN THE HOURS OF 6:00 A.M. THE DAY BEFORE INDEPENDENCE DAY AND 7:00 P.M. THE DAY AFTER INDEPENDENCE DAY. IF INDEPENDENCE DAY IS ON A FRIDAY, SATURDAY, SUNDAY OR MONDAY; THEN BETWEEN THE HOURS OF 6:00 A.M. THE THURSDAY BEFORE INDEPENDENCE DAY AND 7:00 P.M. THE TUESDAY AFTER INDEPENDENCE DAY. |
| 6) | FOR LABOR DAY, BETWEEN THE HOURS OF 6:00 A.M. FRIDAY AND 7:00 P.M. TUESDAY. |
| 7) | FOR THANKSGIVING DAY, BETWEEN THE HOURS OF 6:00 A.M. TUESDAY TO 7:00 P.M. MONDAY. |
| 8) | FOR CHRISTMAS, BETWEEN THE HOURS OF 6:00 A.M. THE FRIDAY BEFORE THE WEEK OF CHRISTMAS DAY AND 7:00 P.M. THE FOLLOWING TUESDAY AFTER THE WEEK OF CHRISTMAS. |

LANE AND SHOULDER CLOSURE REQUIREMENTS

- C) REMOVE LANE CLOSURE DEVICES FROM THE LANE WHEN WORK IS NOT BEING PERFORMED BEHIND THE LANE CLOSURE OR WHEN A LANE CLOSURE IS NO LONGER NEEDED OR AS DIRECTED BY THE ENGINEER.
- D) WHEN PERSONNEL AND/OR EQUIPMENT ARE WORKING WITHIN 15 FT OF AN OPEN TRAVEL LANE, CLOSE THE NEAREST OPEN SHOULDER USING ROADWAY STANDARD DRAWING NO. 1101.04 UNLESS THE WORK AREA IS PROTECTED BY BARRIER OR GUARDRAIL OR A LANE CLOSURE IS INSTALLED.
- E) WHEN PERSONNEL AND/OR EQUIPMENT ARE WORKING ON THE SHOULDER ADJACENT TO AN UNDIVIDED FACILITY AND WITHIN 5 FT OF AN OPEN TRAVEL LANE, CLOSE THE NEAREST OPEN TRAVEL LANE USING ROADWAY STANDARD DRAWING NO. 1101.02 UNLESS THE WORK AREA IS PROTECTED BY BARRIER OR GUARDRAIL.
- F) WHEN PERSONNEL AND/OR EQUIPMENT ARE WORKING ON THE SHOULDER ADJACENT TO A DIVIDED FACILITY AND WITHIN 10 FT OF AN OPEN TRAVEL LANE, CLOSE THE NEAREST OPEN TRAVEL LANE USING ROADWAY STANDARD DRAWING NO. 1101.02 UNLESS THE WORK AREA IS PROTECTED BY BARRIER OR GUARDRAIL.
- F) WHEN PERSONNEL AND/OR EQUIPMENT ARE WORKING WITHIN A LANE OF TRAVEL OF AN UNDIVIDED OR DIVIDED FACILITY, CLOSE THE LANE ACCORDING TO THE TRANSPORTATION MANAGEMENT PLANS, ROADWAY STANDARD DRAWINGS, OR AS DIRECTED BY THE ENGINEER. CONDUCT THE WORK SO THAT ALL PERSONNEL AND/OR EQUIPMENT REMAIN WITHIN THE CLOSED TRAVEL LANE.
- G) DO NOT WORK SIMULTANEOUSLY WITHIN 15 FT ON BOTH SIDES OF AN OPEN TRAVELWAY, RAMP, OR LOOP WITHIN THE SAME LOCATION UNLESS PROTECTED WITH GUARDRAIL OR BARRIER.

SIGNING

- H) INSTALL ADVANCE WORK ZONE WARNING SIGNS WHEN WORK IS WITHIN 40 FT FROM THE EDGE OF TRAVEL LANE AND NO MORE THAN THREE (3) DAYS PRIOR TO THE BEGINNING OF CONSTRUCTION.
- I) ENSURE ALL NECESSARY SIGNING IS IN PLACE PRIOR TO ALTERING ANY TRAFFIC PATTERN.

TRAFFIC CONTROL DEVICES

- J) WHEN LANE CLOSURES ARE NOT IN EFFECT SPACE CHANNELIZING DEVICES IN WORK AREAS NO GREATER IN FEET THAN TWICE THE POSTED SPEED LIMIT (MPH), EXCEPT 10 FT ON-CENTER IN RADII, AND 3 FT OFF THE EDGE OF AN OPEN TRAVELWAY. REFER TO STANDARD SPECIFICATIONS FOR ROADS AND STRUCTURES SECTIONS 1130 (DRUMS), 1135 (CONES) AND 1180 (SKINNY DRUMS) FOR ADDITIONAL REQUIREMENTS.
- K) PLACE ADDITIONAL SETS OF THREE CHANNELIZING DEVICES (DRUMS, CONES OR SKINNY DRUMS) PERPENDICULAR TO THE EDGE OF TRAVELWAY ON 500 FT CENTERS WHEN UNOPENED LANES ARE CLOSED TO TRAFFIC.

10/20/2022 U:\Traffic\Transportation Management\Plan\TCP\PLAN SHEETS\15BPR.58-TMP_02-GENERALNOTES-PHASING.dgn dorichardson

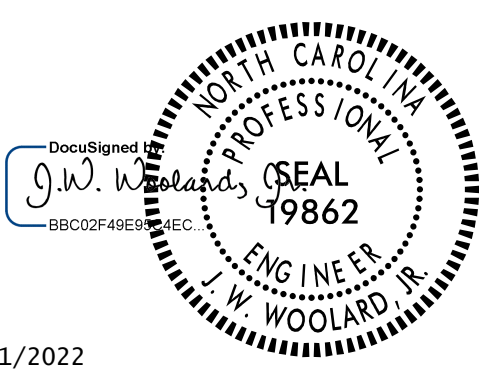
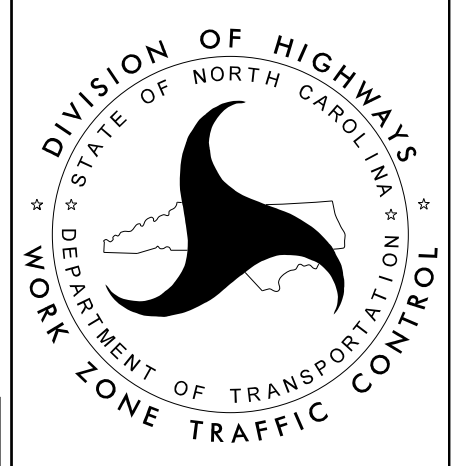
 Stantec Consulting Services Inc. 801 Jones Franklin Road Suite 300 Raleigh, NC 27606 Tel. 919.851.6866 Fax. 919.851.7024 www.stantec.com License No. F-0672	 10/21/2022 DOCUMENT NOT CONSIDERED FINAL UNLESS ALL SIGNATURES COMPLETED		<h2 style="margin: 0;">GENERAL NOTES</h2>
---	---	---	---

PHASING

BRIDGE 250327

PRIOR TO ANY WORK OPERATIONS, INSTALL WORK ZONE ADVANCE WARNING SIGNS PER RSD 1101.01, SHEET 1 OF 3.

PHASE I (TMP-5 THRU TMP-7)

USING TEMPORARY LANE CLOSURES PER RSD 1101.02, SHEET 4 OF 14 AND AND DETAILS SHOWN ON TMP-5 THRU TMP-7, PERFORM THE FOLLOWING, IN ORDER, ON EACH STRUCTURE:

- 1- PERFORM SHOTBLASTING AND SILANE DECK TREATMENT ON A SECTION OF THE BRIDGE DECK.
- 2- INSTALL FINAL PAVEMENT MARKINGS ON THIS SECTION OF THE BRIDGE DECK. (SEE PM PLANS)
- 3- COVER OR REMOVE ANY TRAFFIC CONTROL DEVICES AND OPEN TO FINAL TRAFFIC PATTERN.

PHASE II (TMP-8 THRU TMP-10)

USING TEMPORARY LANE CLOSURES PER RSD 1101.02, SHEET 4 OF 14 AND AND DETAILS SHOWN ON TMP-8 THRU TMP-10, PERFORM THE FOLLOWING, IN ORDER, ON EACH STRUCTURE:

- 1- PERFORM SHOTBLASTING AND SILANE DECK TREATMENT ON A SECTION OF THE BRIDGE DECK.
- 2- INSTALL FINAL PAVEMENT MARKINGS ON THIS SECTION OF THE BRIDGE DECK. (SEE PM PLANS)
- 3- COVER OR REMOVE ANY TRAFFIC CONTROL DEVICES AND OPEN TO FINAL TRAFFIC PATTERN.

PHASING

BRIDGE 250352

PRIOR TO ANY WORK OPERATIONS, INSTALL WORK ZONE ADVANCE WARNING SIGNS PER RSD 1101.01, SHEET 1 OF 3.

PHASE I (TMP-11 THRU TMP-12)

USING TEMPORARY LANE CLOSURES PER RSD 1101.02, SHEET 4 OF 14 AND AND DETAILS SHOWN ON TMP-11 THRU TMP-12, PERFORM THE FOLLOWING, IN ORDER, ON EACH STRUCTURE:

- 1- PERFORM SHOTBLASTING AND SILANE DECK TREATMENT ON A SECTION OF THE BRIDGE DECK.
- 2- INSTALL FINAL PAVEMENT MARKINGS ON THIS SECTION OF THE BRIDGE DECK. (SEE PM PLANS)
- 3- COVER OR REMOVE ANY TRAFFIC CONTROL DEVICES AND OPEN TO FINAL TRAFFIC PATTERN.

PHASE II (TMP-13 THRU TMP-14)

USING TEMPORARY LANE CLOSURES PER RSD 1101.02, SHEET 4 OF 14 AND AND DETAILS SHOWN ON TMP-13 THRU TMP-14, PERFORM THE FOLLOWING, IN ORDER, ON EACH STRUCTURE:

- 1- PERFORM SHOTBLASTING AND SILANE DECK TREATMENT ON A SECTION OF THE BRIDGE DECK.
- 2- INSTALL FINAL PAVEMENT MARKINGS ON THIS SECTION OF THE BRIDGE DECK. (SEE PM PLANS)
- 3- COVER OR REMOVE ANY TRAFFIC CONTROL DEVICES AND OPEN TO FINAL TRAFFIC PATTERN.

PHASING

BRIDGE 250362

PRIOR TO ANY WORK OPERATIONS, INSTALL WORK ZONE ADVANCE WARNING SIGNS PER RSD 1101.01, SHEET 1 OF 3.

PHASE I (TMP-15 THRU TMP-16)

USING TEMPORARY LANE CLOSURES PER RSD 1101.02, SHEET 4 OF 14 AND AND DETAILS SHOWN ON TMP-15 THRU TMP-16, PERFORM THE FOLLOWING, IN ORDER, ON EACH STRUCTURE:

- 1- PERFORM SHOTBLASTING AND SILANE DECK TREATMENT ON A SECTION OF THE BRIDGE DECK.
- 2- INSTALL FINAL PAVEMENT MARKINGS ON THIS SECTION OF THE BRIDGE DECK. (SEE PM PLANS)
- 3- COVER OR REMOVE ANY TRAFFIC CONTROL DEVICES AND OPEN TO FINAL TRAFFIC PATTERN.

PHASE II (TMP-17 THRU TMP-18)

USING TEMPORARY LANE CLOSURES PER RSD 1101.02, SHEET 4 OF 14 AND AND DETAILS SHOWN ON TMP-17 THRU TMP-18, PERFORM THE FOLLOWING, IN ORDER, ON EACH STRUCTURE:

- 1- PERFORM SHOTBLASTING AND SILANE DECK TREATMENT ON A SECTION OF THE BRIDGE DECK.
- 2- INSTALL FINAL PAVEMENT MARKINGS ON THIS SECTION OF THE BRIDGE DECK. (SEE PM PLANS)
- 3- COVER OR REMOVE ANY TRAFFIC CONTROL DEVICES AND OPEN TO FINAL TRAFFIC PATTERN.

10/20/2022 U:\Traffic\Transportation Management Plan\TCP\PLAN SHEETS\58BPR.58-TMP_03_PHASING.dgn dorichardson



Stantec Consulting Services Inc.
801 Jones Franklin Road
Suite 300
Raleigh, NC 27606
Tel. 919.851.6866
Fax. 919.851.7024
www.stantec.com
License No. F-0672

10/21/2022

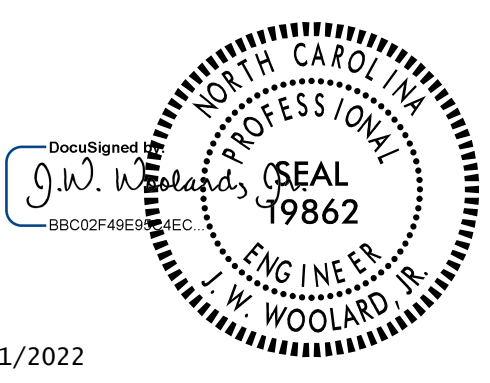

**DOCUMENT NOT CONSIDERED FINAL
UNLESS ALL SIGNATURES COMPLETED**

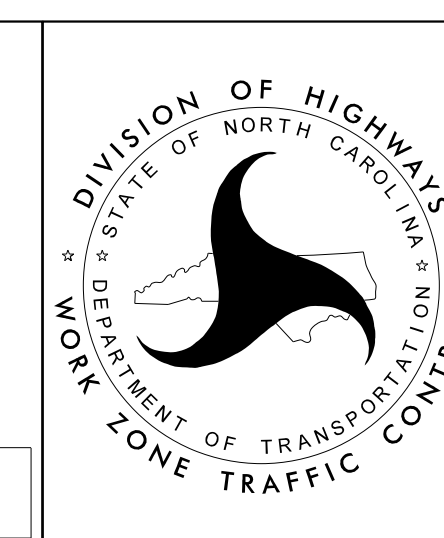

**TEMPORARY TRAFFIC
CONTROL PHASING**

PHASING

BRIDGE 250326

PRIOR TO ANY WORK OPERATIONS, INSTALL WORK ZONE ADVANCE WARNING SIGNS PER RSD 1101.01, SHEET 1 OF 3.

USING TEMPORARY LANE CLOSURES PER RSD 1101.02, SHEET 4 OF 14, PERFORM THE FOLLOWING, IN ORDER, ON STRUCTURE 250326:

- 1- PERFORM SHOTBLASTING AND SILANE DECK TREATMENT ON A SECTION OF THE BRIDGE DECK.
- 2- INSTALL FINAL PAVEMENT MARKINGS ON THIS SECTION OF THE BRIDGE DECK. (SEE PM PLANS)
- 3- REMOVE ANY TRAFFIC CONTROL DEVICES AND OPEN TO FINAL TRAFFIC PATTERN.
- 4- REPEAT STEPS 1-3 UNTIL THE ENTIRE BRIDGE DECK IS COMPLETE.

SEE RSD 1101.02 4/14

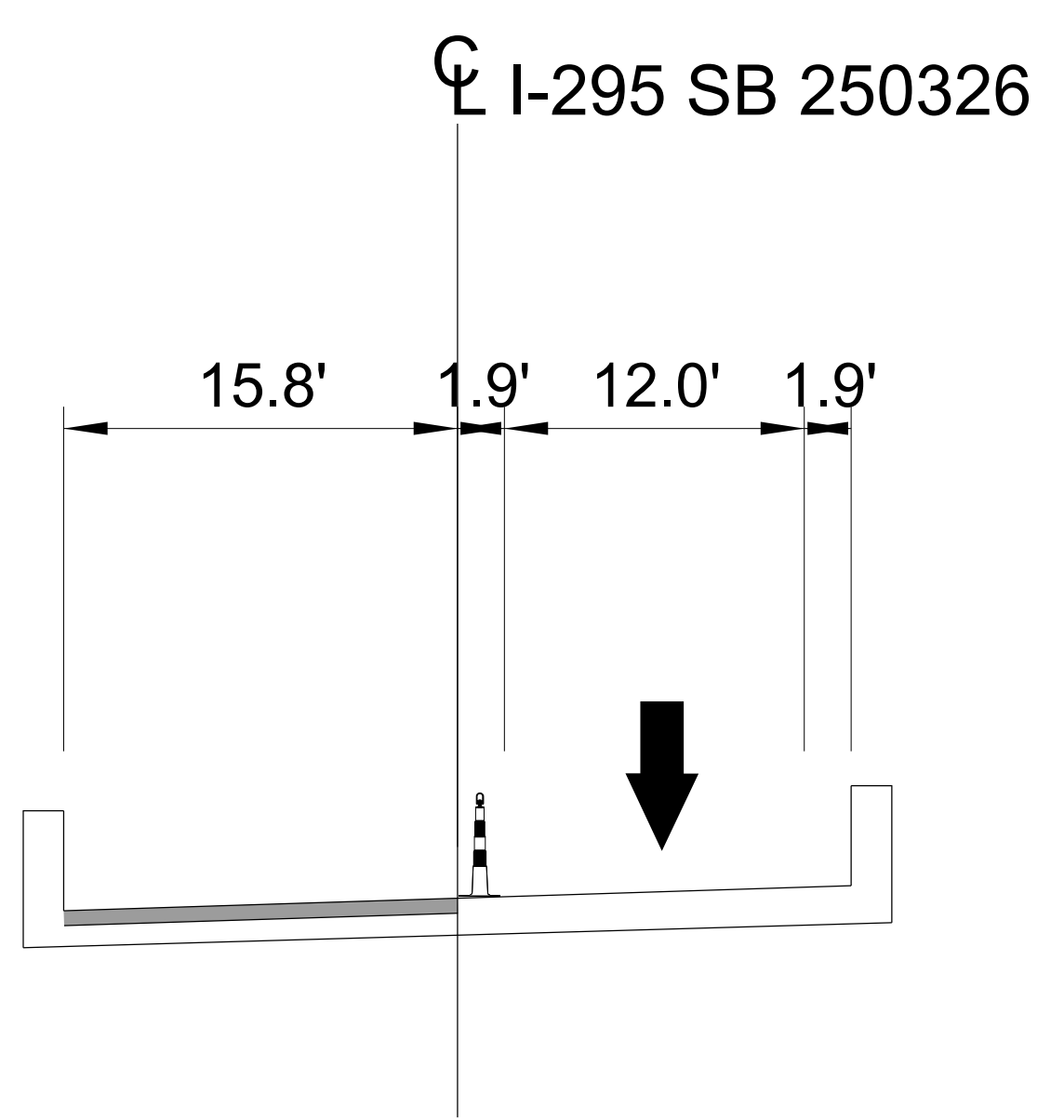

SEE RSD 1101.02 4/14

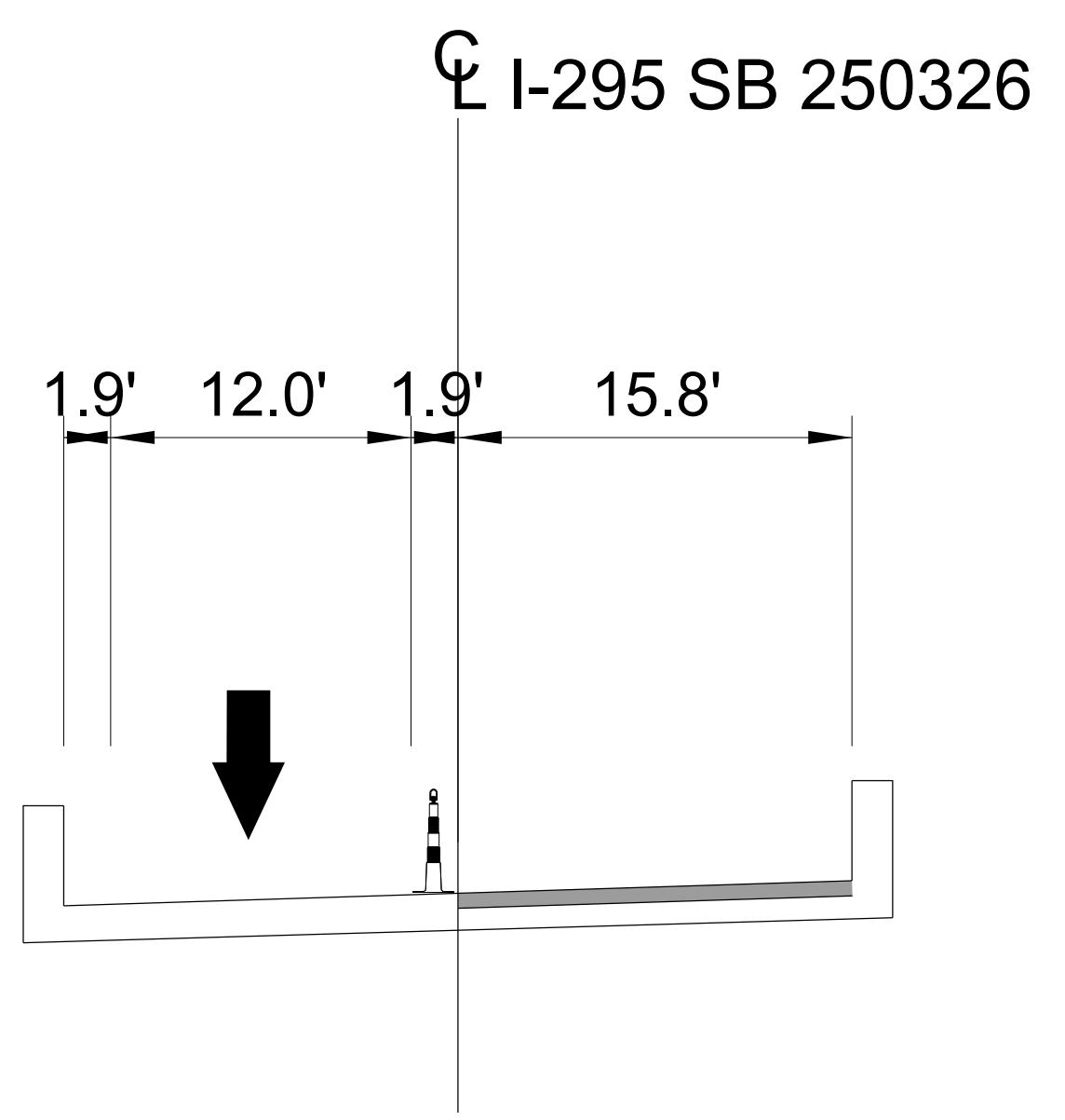

10/20/2022
 U:\Traffic\Transportation Management\Plan\TCP\PLAN SHEETS\58BPR_58_TMP_04_326_PHASING.dgn
 dorichardson

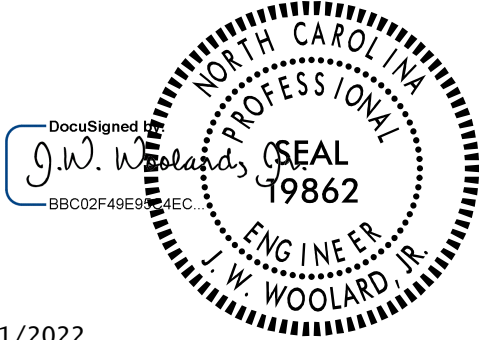
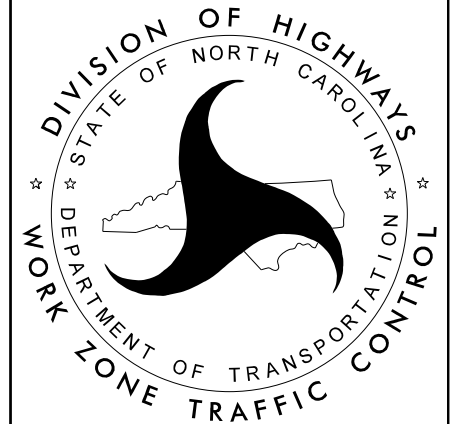
 <p>Stantec Consulting Services Inc. 801 Jones Franklin Road Suite 300 Raleigh, NC 27606 Tel. 919.851.6866 Fax. 919.851.7024 www.stantec.com License No. F-0672</p>	<p style="font-size: small;">DocuSigned by: J.W. Woolard BB0C0F49E1EC</p>  <p style="font-size: x-small;">10/21/2022</p> <p style="font-weight: bold; font-size: small;">DOCUMENT NOT CONSIDERED FINAL UNLESS ALL SIGNATURES COMPLETED</p>	 <p style="font-size: x-small;">DIVISION OF HIGHWAYS STATE OF NORTH CAROLINA DEPARTMENT OF TRANSPORTATION WORK ZONE TRAFFIC CONTROL</p>	<h2 style="margin: 0;">BRIDGE 250326</h2>
---	--	---	---

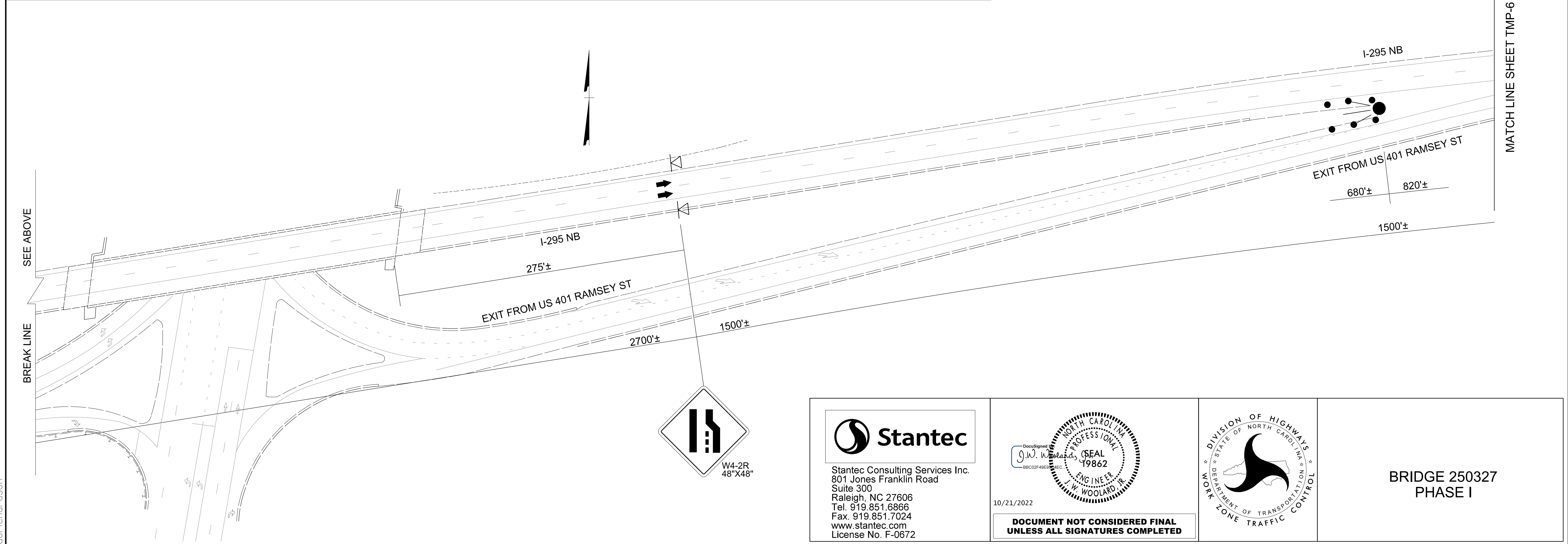
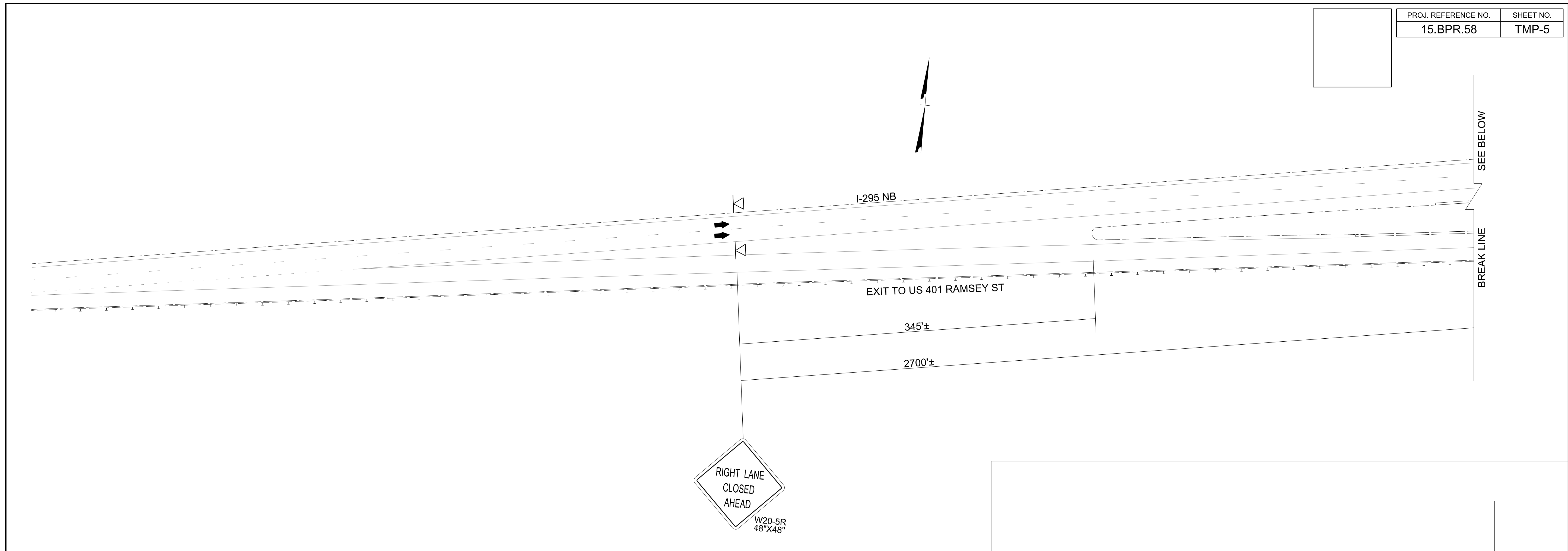

10/20/2022
 U:\Traffic\Transportation Management Plan\TCP\PLAN SHEETS\15BPR.58_TMP_05_327_PHASE_01.dgn
 dorichardson

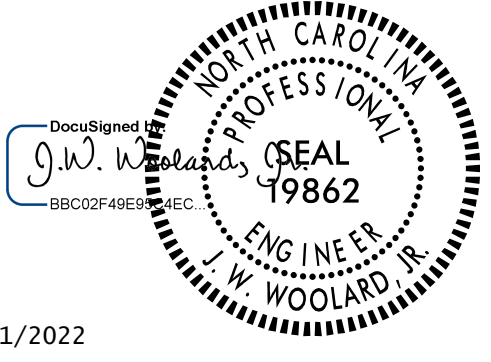

 Stantec Consulting Services Inc.
 801 Jones Franklin Road
 Suite 300
 Raleigh, NC 27606
 Tel. 919.851.6866
 Fax. 919.851.7024
 www.stantec.com
 License No. F-0672

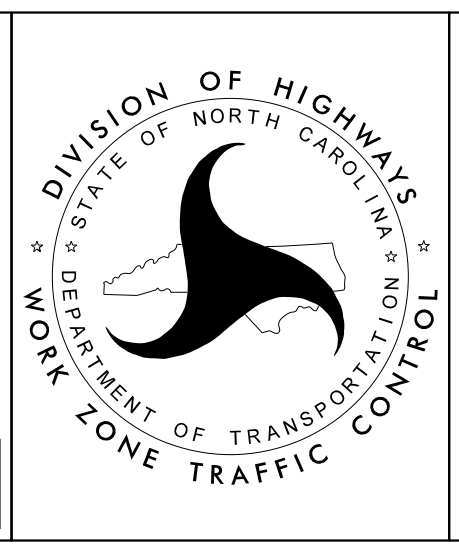
10/21/2022

**DOCUMENT NOT CONSIDERED FINAL
 UNLESS ALL SIGNATURES COMPLETED**

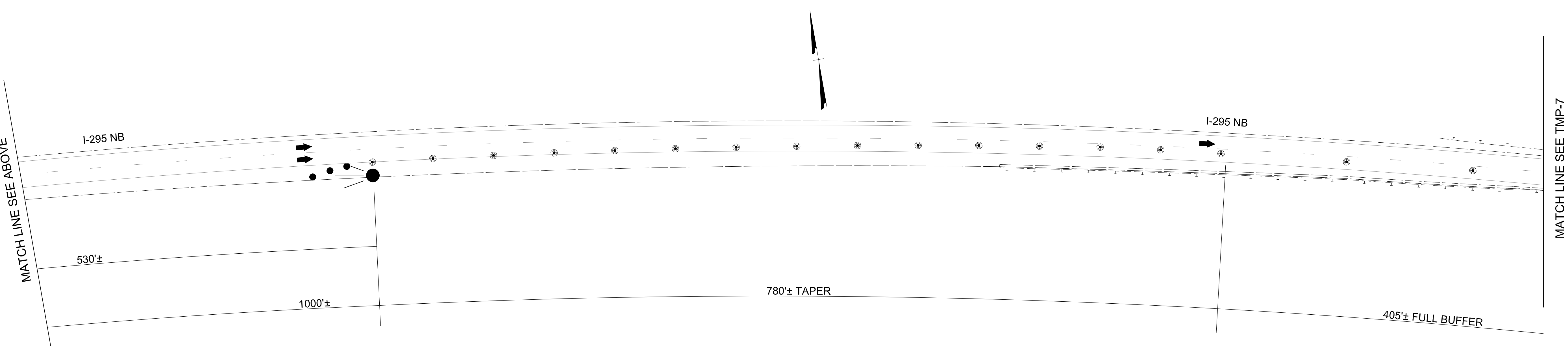
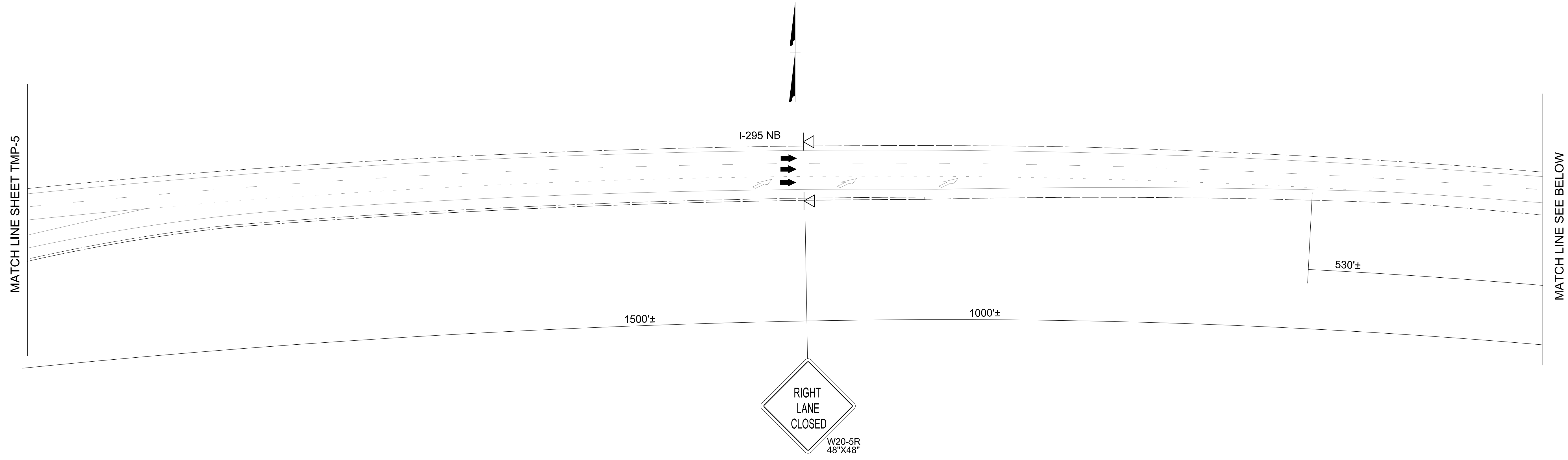

**BRIDGE 250327
 PHASE I**

PROJ. REFERENCE NO.	SHEET NO.
15.BPR.58	TMP-6



10/20/2022
 U:\Traffic\Transportation Management\Plan\TCP\PLAN SHEETS\15BPR.58_TMP_06_327_PHASE_01.dgn
 dorichardson

 Stantec Consulting Services Inc.
 801 Jones Franklin Road
 Suite 300
 Raleigh, NC 27606
 Tel. 919.851.6866
 Fax. 919.851.7024
 www.stantec.com
 License No. F-0672

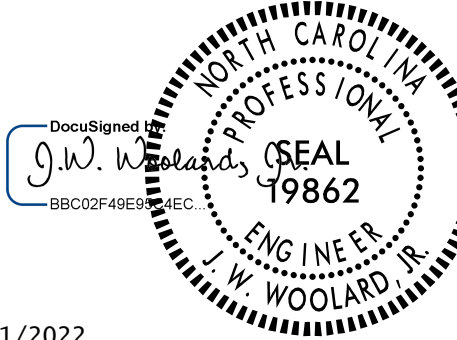
10/21/2022

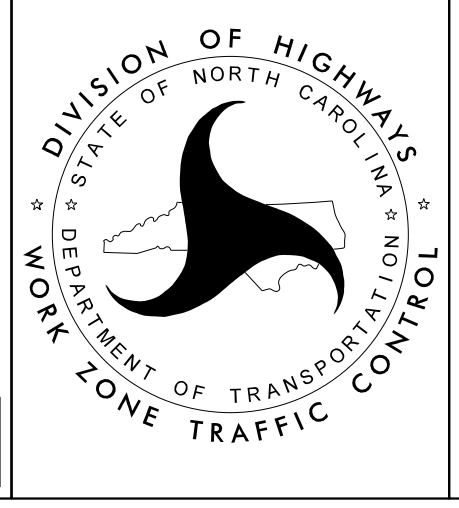
**DOCUMENT NOT CONSIDERED FINAL
 UNLESS ALL SIGNATURES COMPLETED**

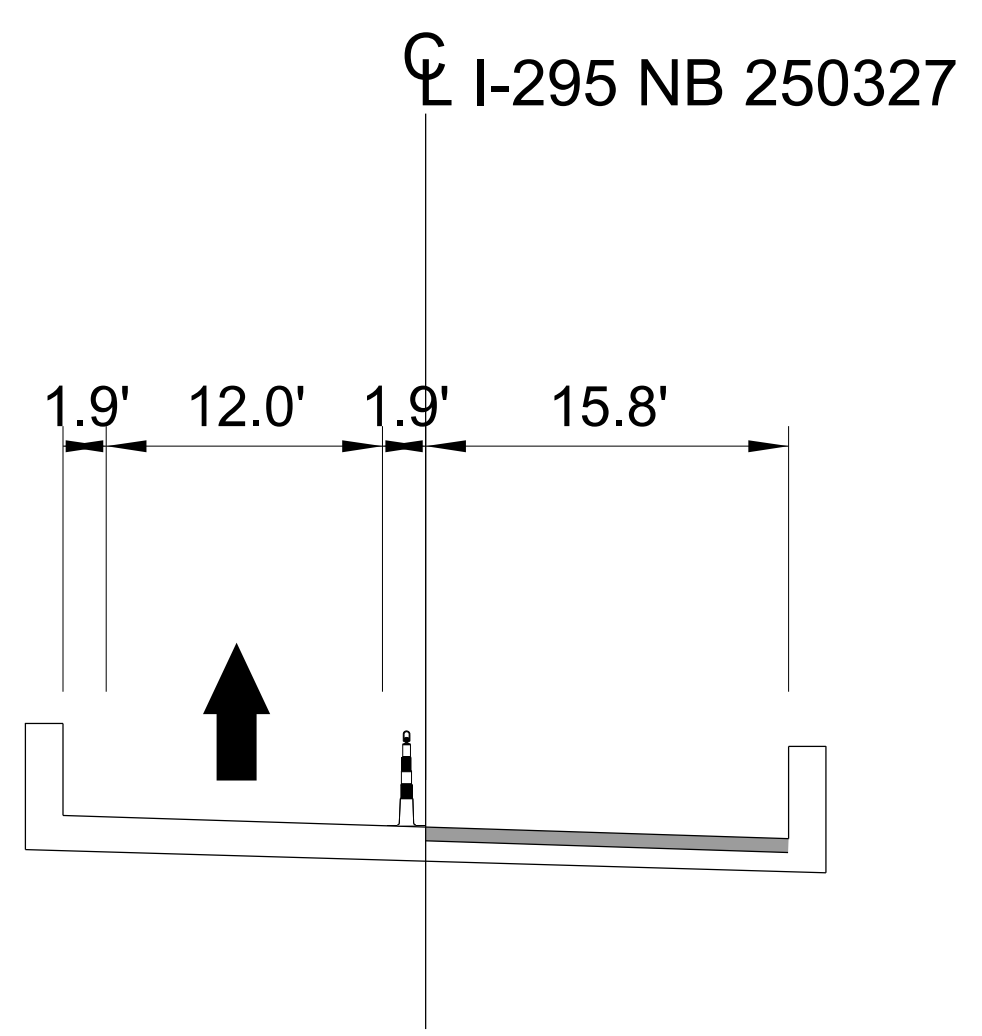
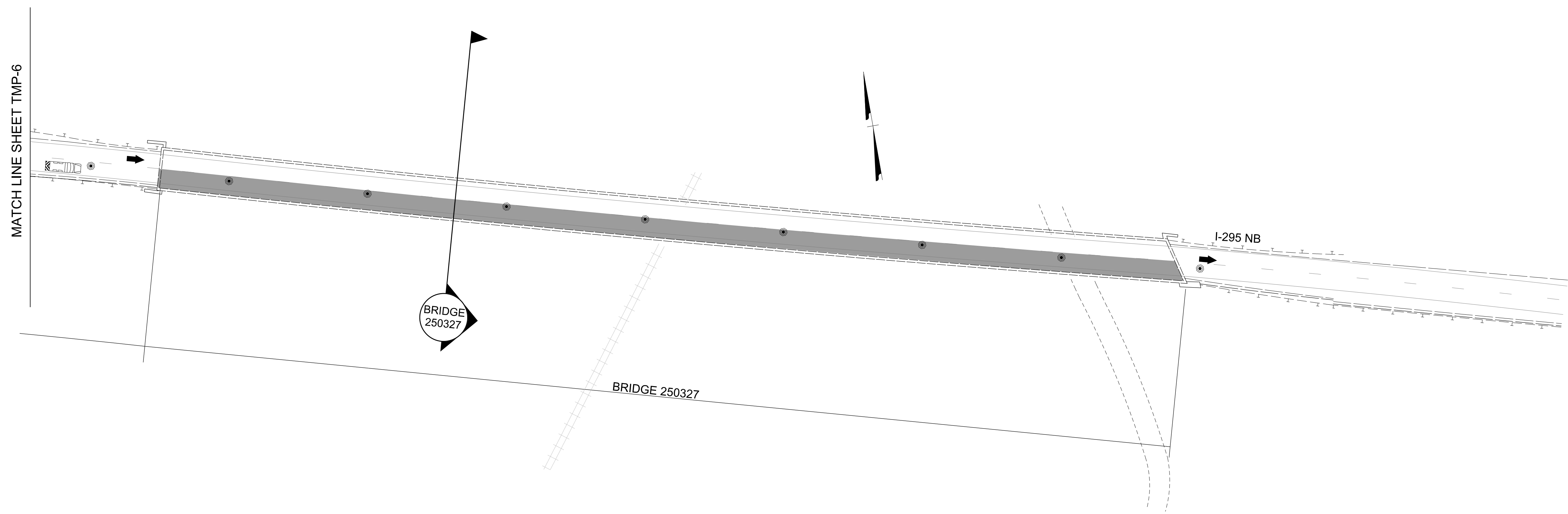

**BRIDGE 250327
 PHASE I**



10/20/2022
 U:\Traffic\Transportation Management\Plan\TCP\PLAN SHEETS\58BPR.58-TMP_07_327_PHASE-01.dgn
 dorichardson

Stantec Consulting Services Inc.
 801 Jones Franklin Road
 Suite 300
 Raleigh, NC 27606
 Tel. 919.851.6866
 Fax. 919.851.7024
 www.stantec.com
 License No. F-0672

10/21/2022

**DOCUMENT NOT CONSIDERED FINAL
UNLESS ALL SIGNATURES COMPLETED**

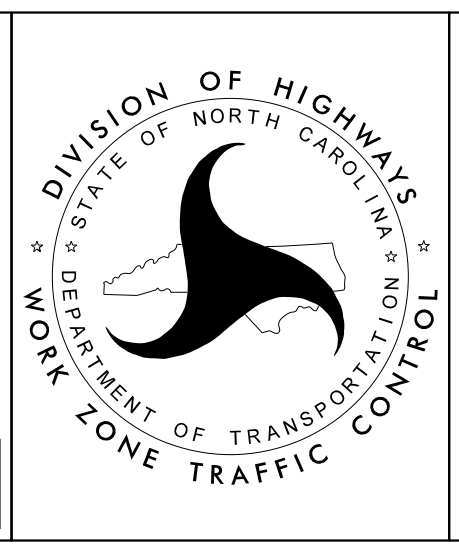

**BRIDGE 250327
PHASE I**

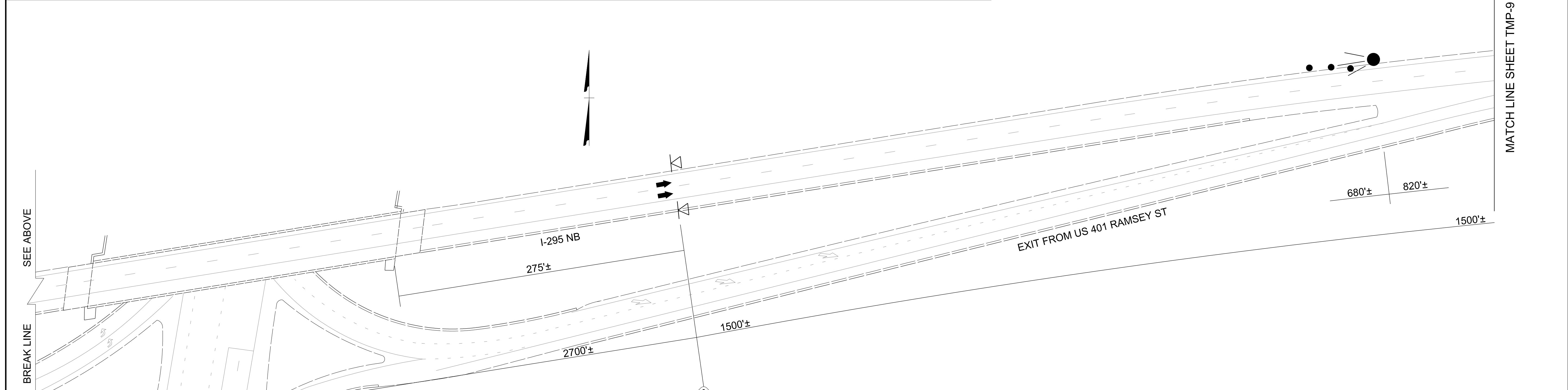
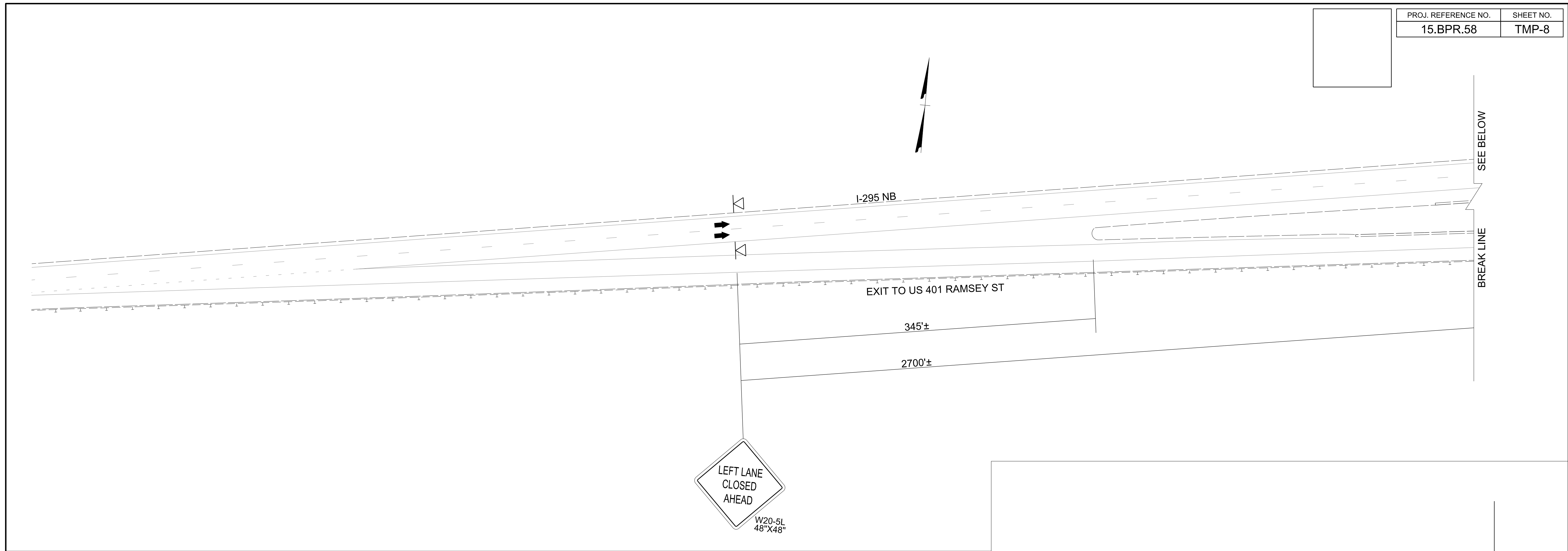

10/20/2022
 U:\Traffic\Transportation Management Plan\TCP\PLAN SHEETS\15BPR.58_TMP_08_327_PHASE_02.dgn
 dorichardson

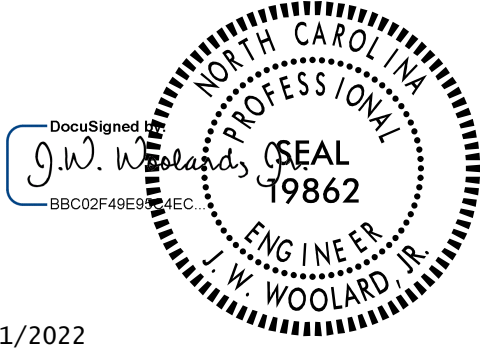

 Stantec Consulting Services Inc.
 801 Jones Franklin Road
 Suite 300
 Raleigh, NC 27606
 Tel. 919.851.6866
 Fax. 919.851.7024
 www.stantec.com
 License No. F-0672

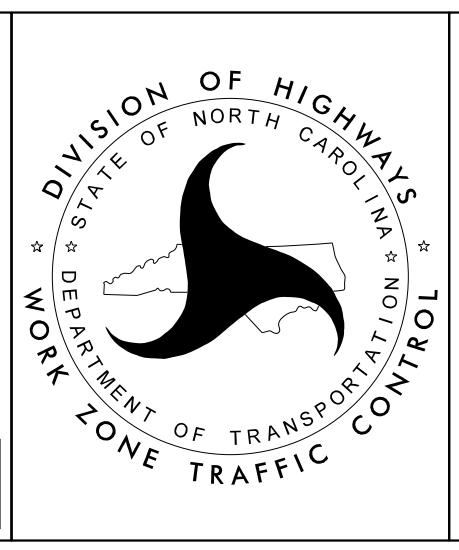
10/21/2022

**DOCUMENT NOT CONSIDERED FINAL
 UNLESS ALL SIGNATURES COMPLETED**

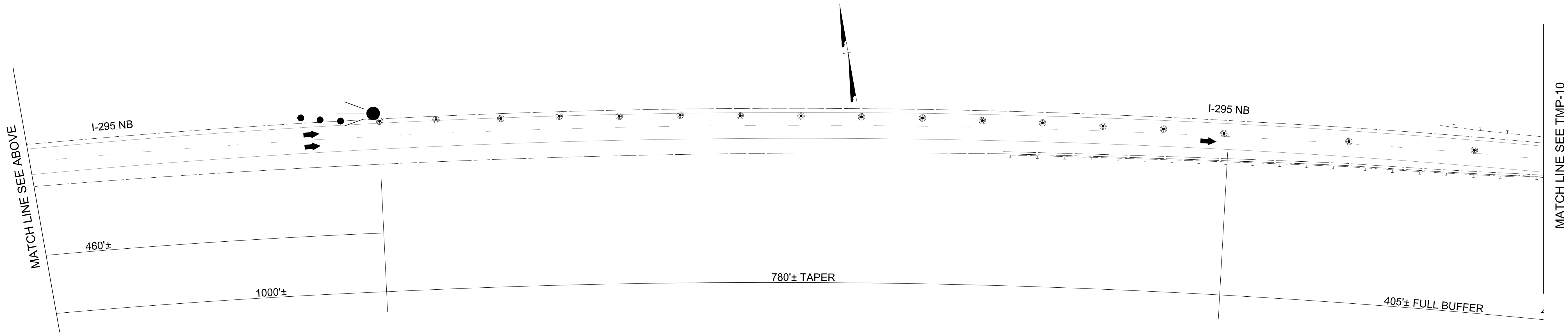
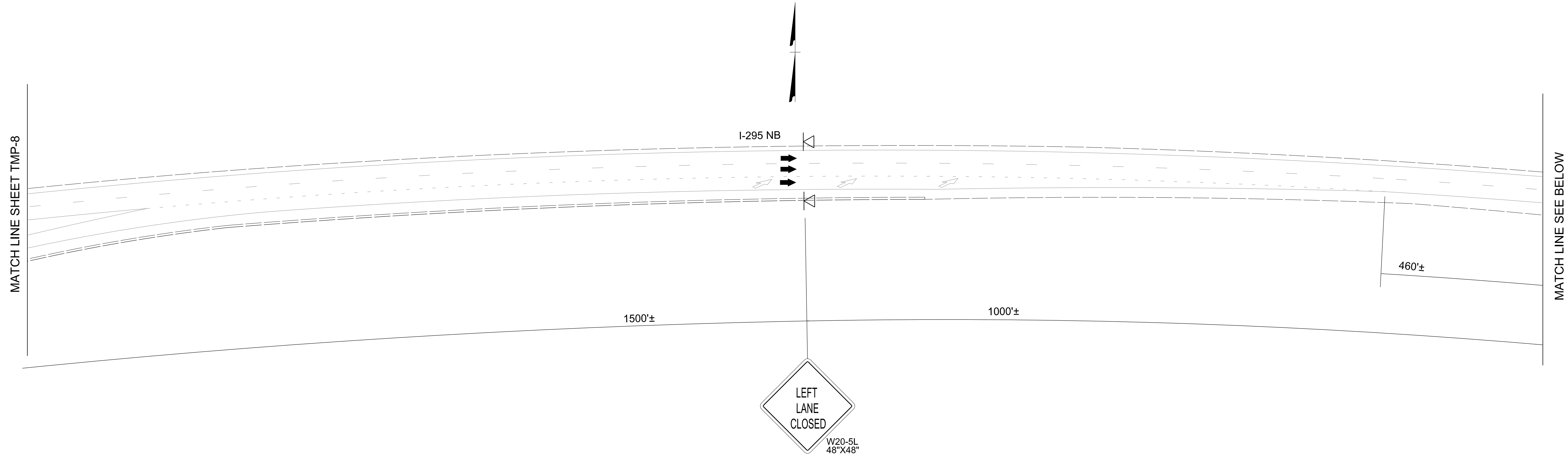

**BRIDGE 250327
 PHASE II**

PROJ. REFERENCE NO.	SHEET NO.
15.BPR.58	TMP-9



10/20/2022
 U:\Traffic\Transportation Management\Plan\TCP\PLAN SHEETS\15BPR.58-TMP_09_327_PHASE-02.dgn
 dorichardson

Stantec
 Stantec Consulting Services Inc.
 801 Jones Franklin Road
 Suite 300
 Raleigh, NC 27606
 Tel. 919.851.6866
 Fax. 919.851.7024
 www.stantec.com
 License No. F-0672

10/21/2022
**DOCUMENT NOT CONSIDERED FINAL
 UNLESS ALL SIGNATURES COMPLETED**

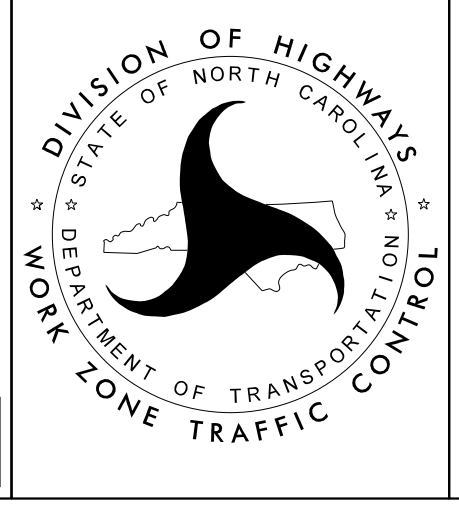

**BRIDGE 250327
 PHASE II**

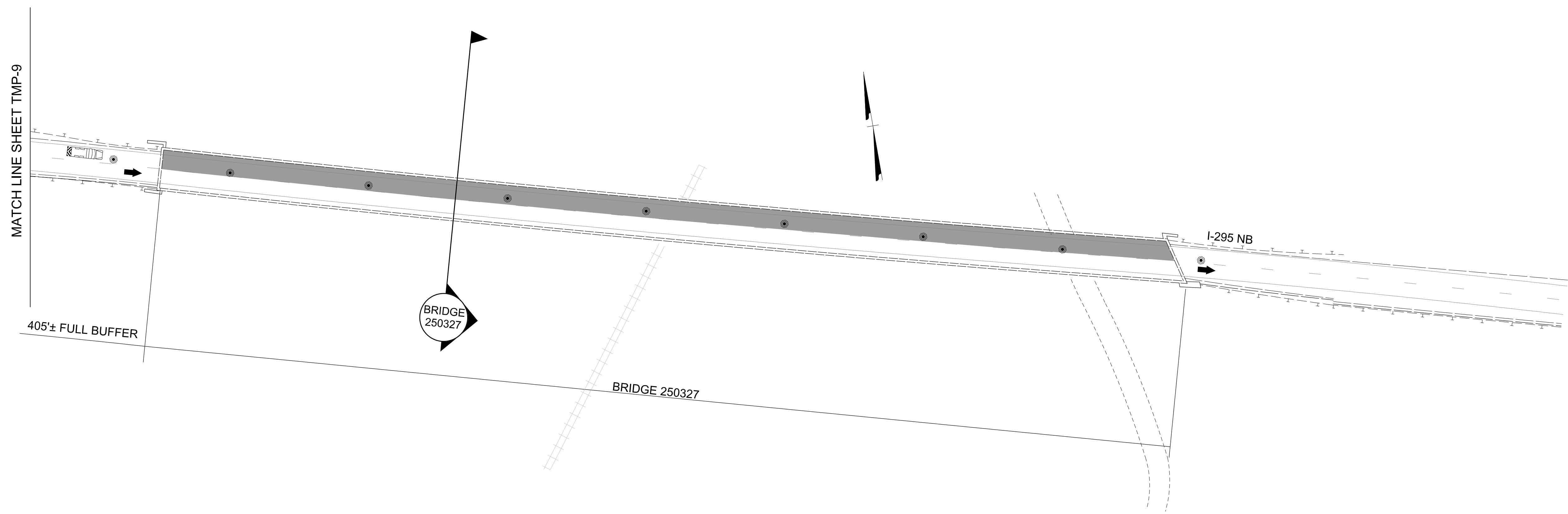

MATCH LINE SEE ABOVE

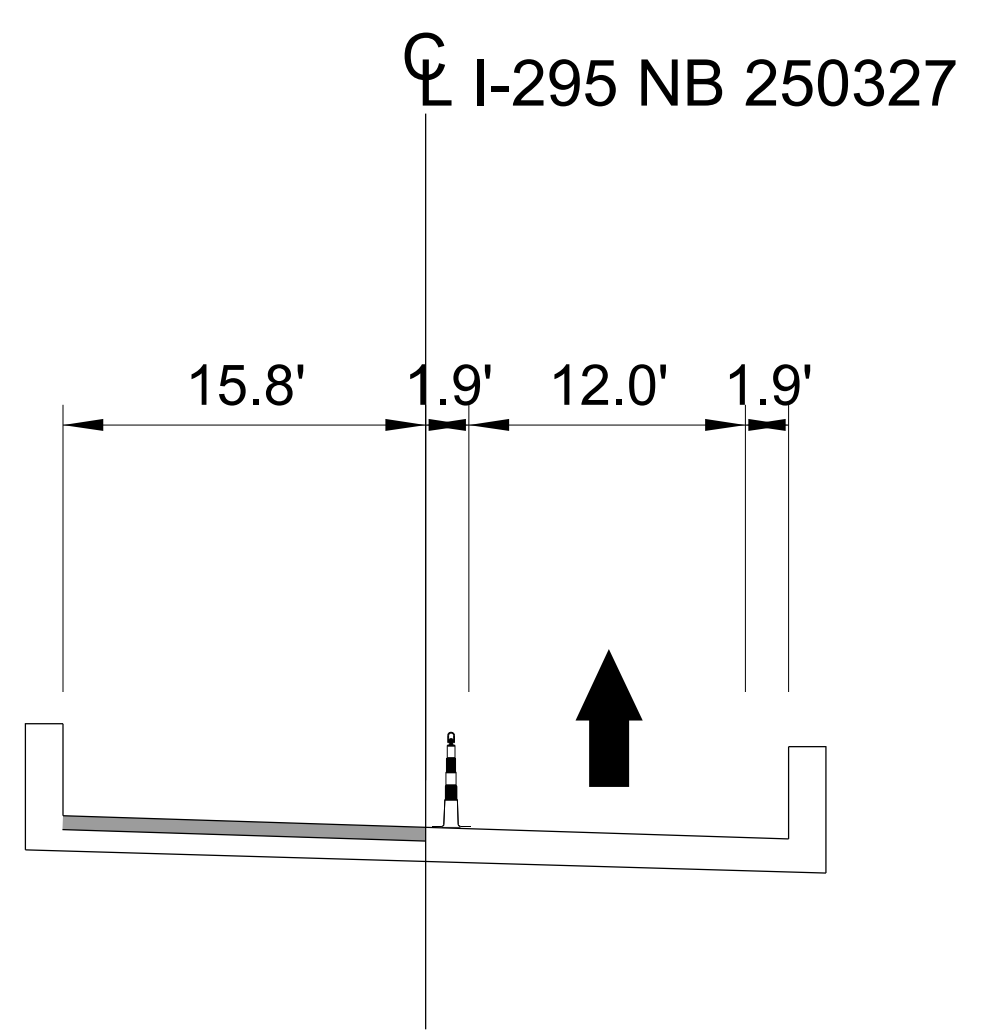

10/20/2022
U:\Traffic\Transportation Management\Plan\TCP\PLAN SHEETS\15BPR_58_TMP_10_327_PHASE_02.dgn
dorichardson

Stantec
 Stantec Consulting Services Inc.
 801 Jones Franklin Road
 Suite 300
 Raleigh, NC 27606
 Tel. 919.851.6866
 Fax. 919.851.7024
 www.stantec.com
 License No. F-0672

10/21/2022
**DOCUMENT NOT CONSIDERED FINAL
 UNLESS ALL SIGNATURES COMPLETED**

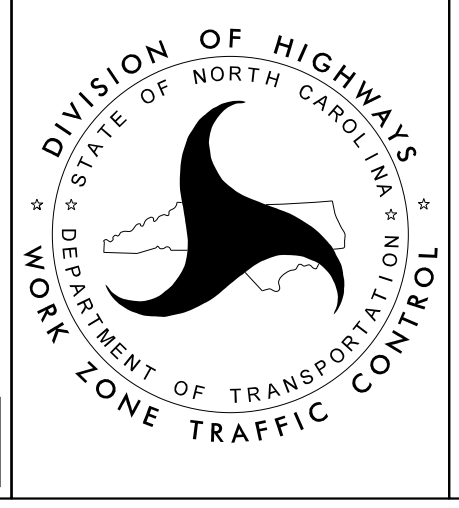

**BRIDGE 250327
 PHASE II**

Logo of the North Carolina Department of Transportation, Division of Highways, Work Zone Traffic Control.

NOTE
SEE TMP-11A FOR NC 210 (MURCHISON RD) RAMPS

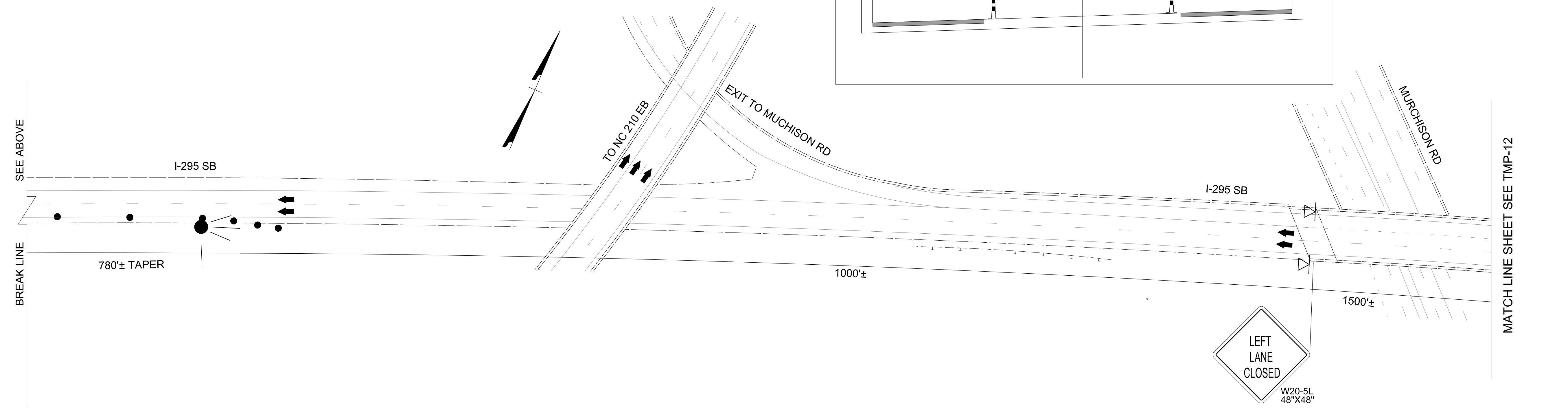
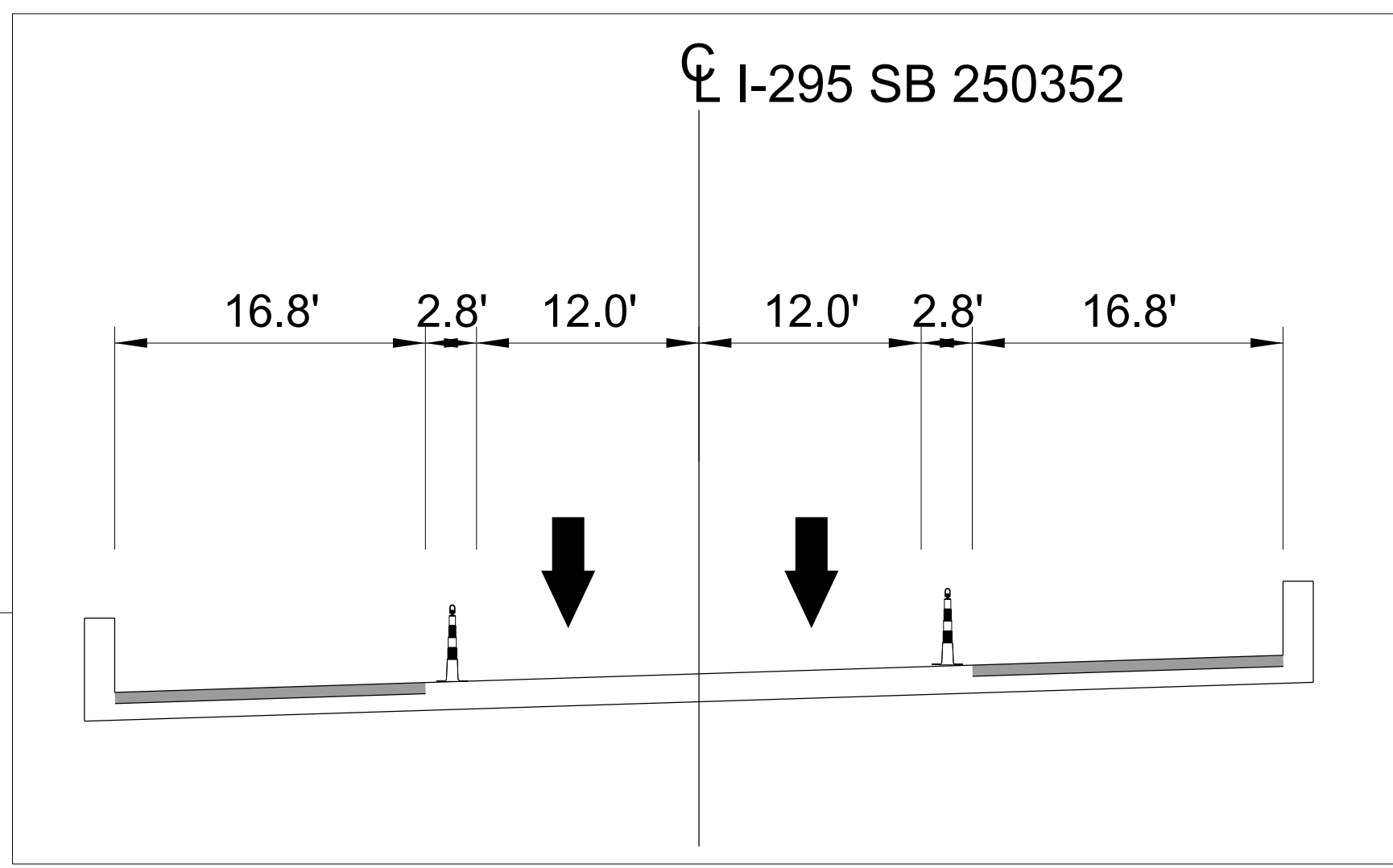
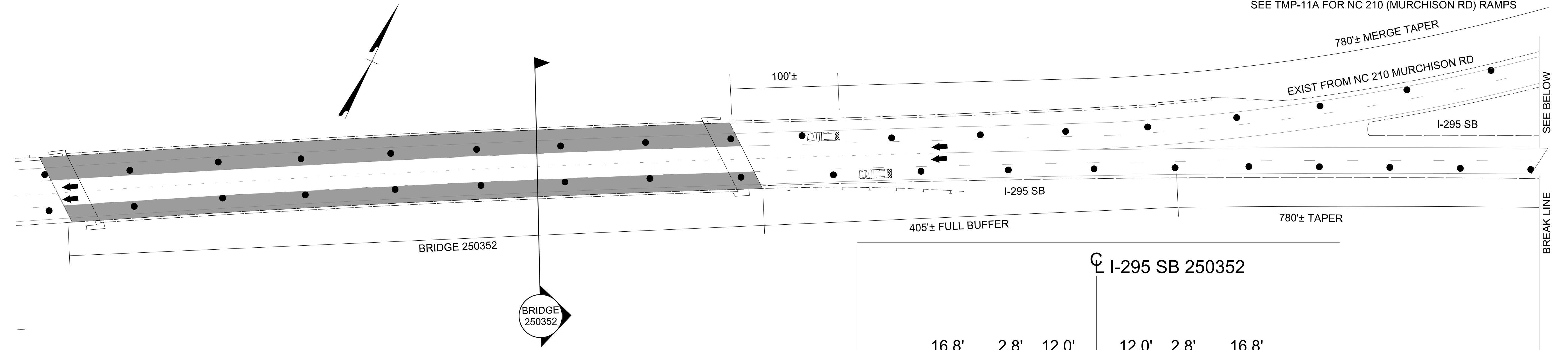

10/20/2022
U:\Traffic\Transportation Management\Plan\TCP\PLAN SHEETS\15BPR.58-TMP-11-352-PHASE-01.dgn
dorichardson

Stantec
Stantec Consulting Services Inc.
801 Jones Franklin Road
Suite 300
Raleigh, NC 27606
Tel. 919.851.6866
Fax. 919.851.7024
www.stantec.com
License No. F-0672

10/21/2022
DOCUMENT NOT CONSIDERED FINAL
UNLESS ALL SIGNATURES COMPLETED

DIVISION OF HIGHWAYS
DEPARTMENT OF TRANSPORTATION
WORK ZONE TRAFFIC CONTROL

**BRIDGE 250352
PHASE I**

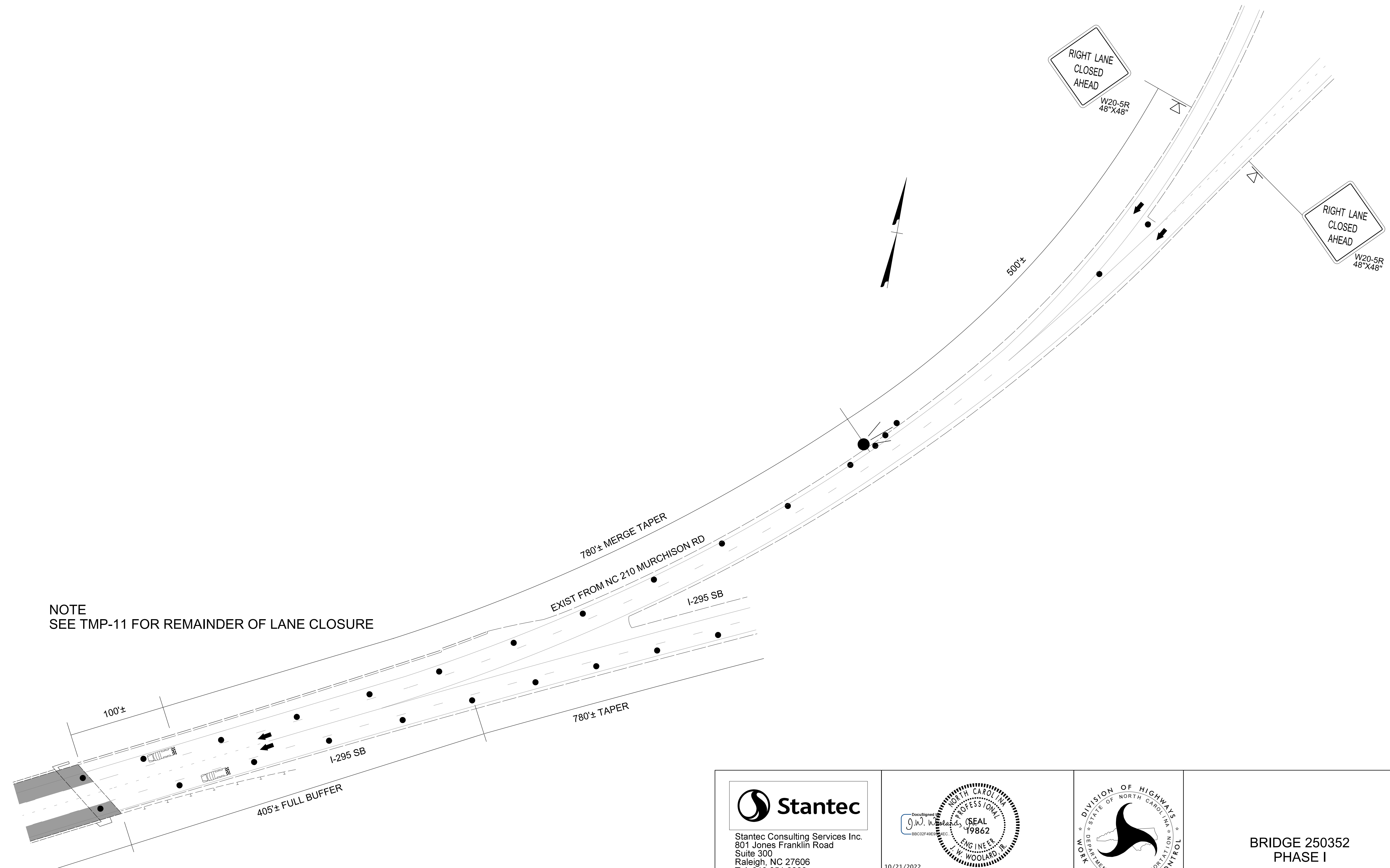

NOTE
SEE TMP-11 FOR REMAINDER OF LANE CLOSURE

10/20/2022
U:\Traffic\Transportation Management Plan\TCP\PLAN SHEETS\58BPR.58-TMP-11A-352-PHASE-01.dgn
dorichardson

Stantec Consulting Services Inc.
801 Jones Franklin Road
Suite 300
Raleigh, NC 27606
Tel. 919.851.6866
Fax. 919.851.7024
www.stantec.com
License No. F-0672

10/21/2022

**DOCUMENT NOT CONSIDERED FINAL
UNLESS ALL SIGNATURES COMPLETED**

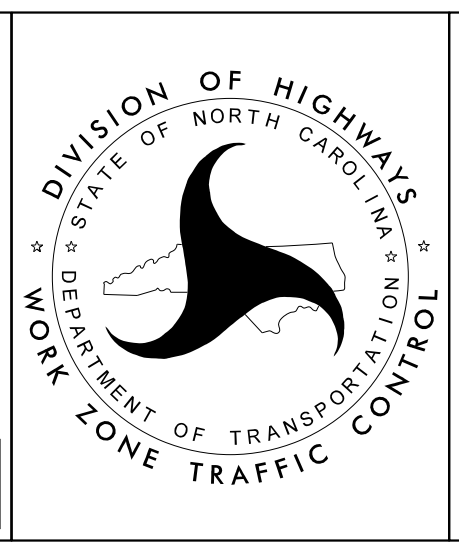

**BRIDGE 250352
PHASE I**

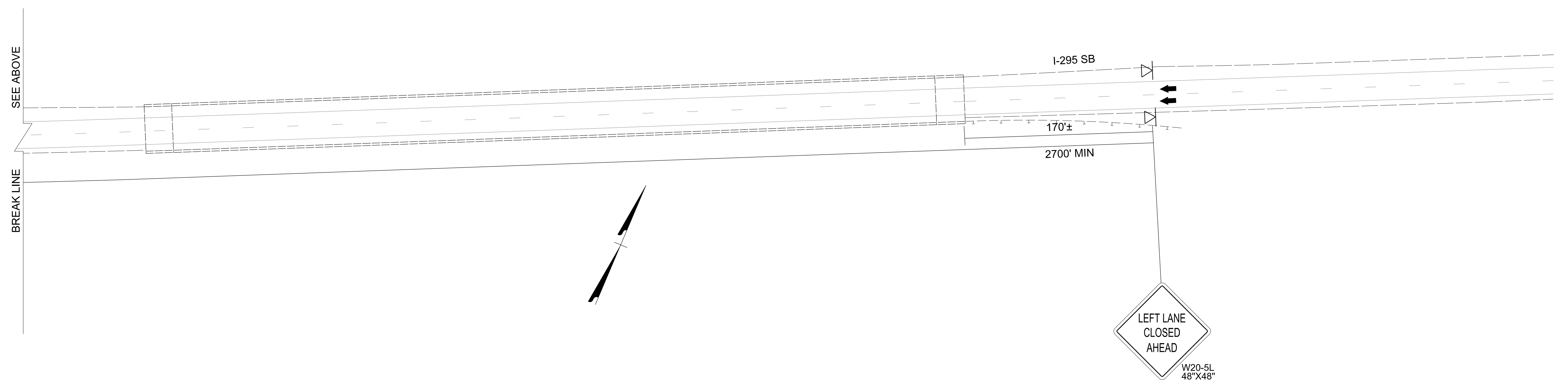
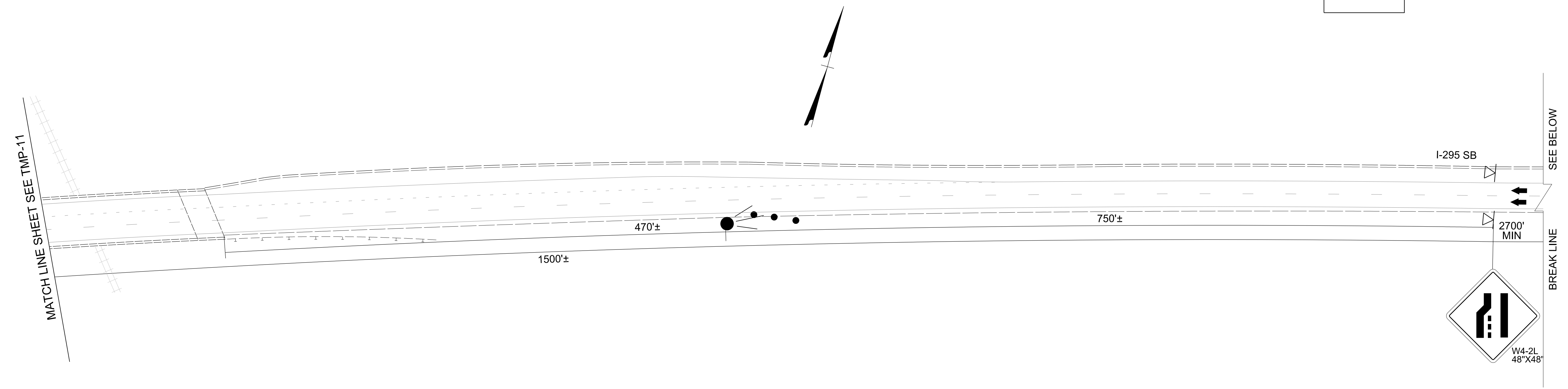

10/20/2022
U:\Traffic\Transportation Management\Plan\TCP\PLAN SHEETS\15BPR.58_TMP_12_352_PHASE_01.dgn
dorichardson

Stantec
Stantec Consulting Services Inc.
801 Jones Franklin Road
Suite 300
Raleigh, NC 27606
Tel. 919.851.6866
Fax. 919.851.7024
www.stantec.com
License No. F-0672

10/21/2022

DOCUMENT NOT CONSIDERED FINAL
UNLESS ALL SIGNATURES COMPLETED

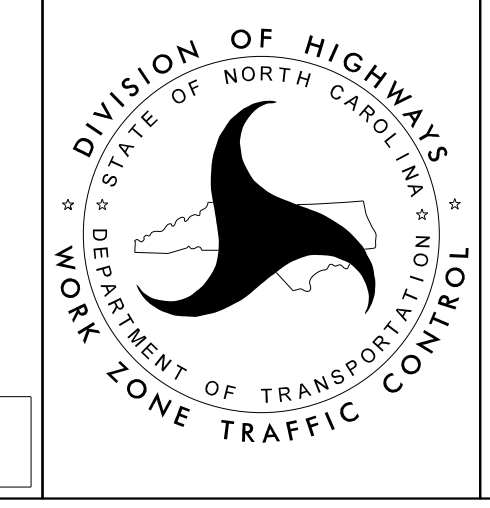

BRIDGE 250352
PHASE I

NOTE
SEE TMP-11A FOR NC 210 (MURCHISON RD) RAMPS

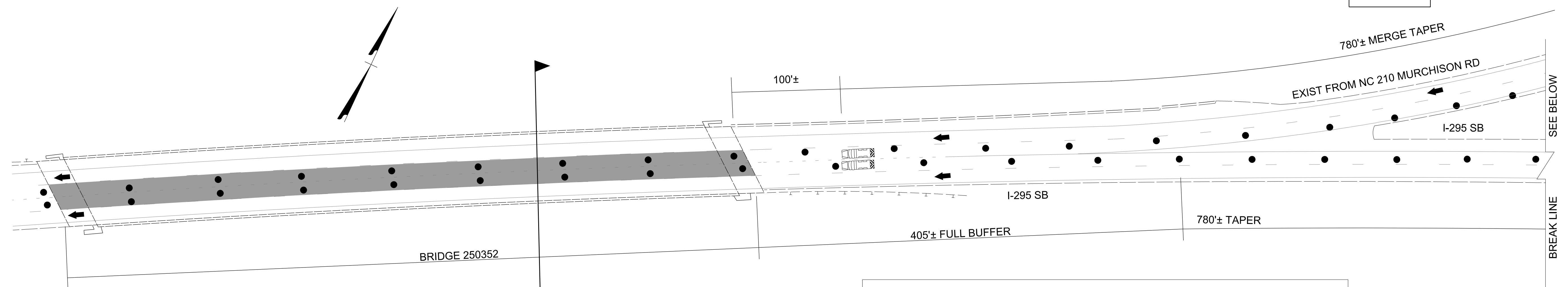

BRIDGE 250352

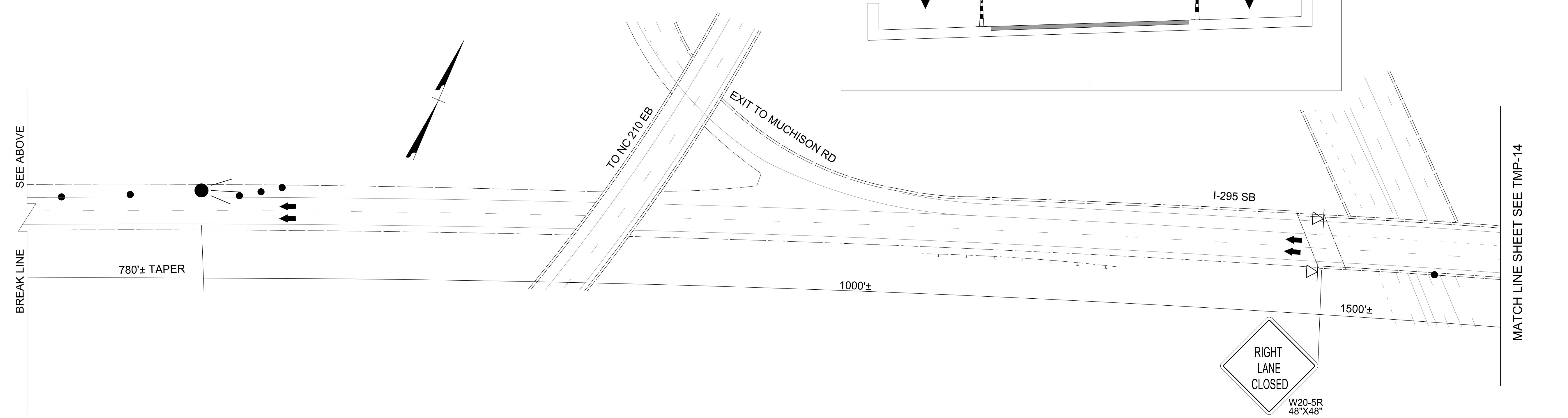
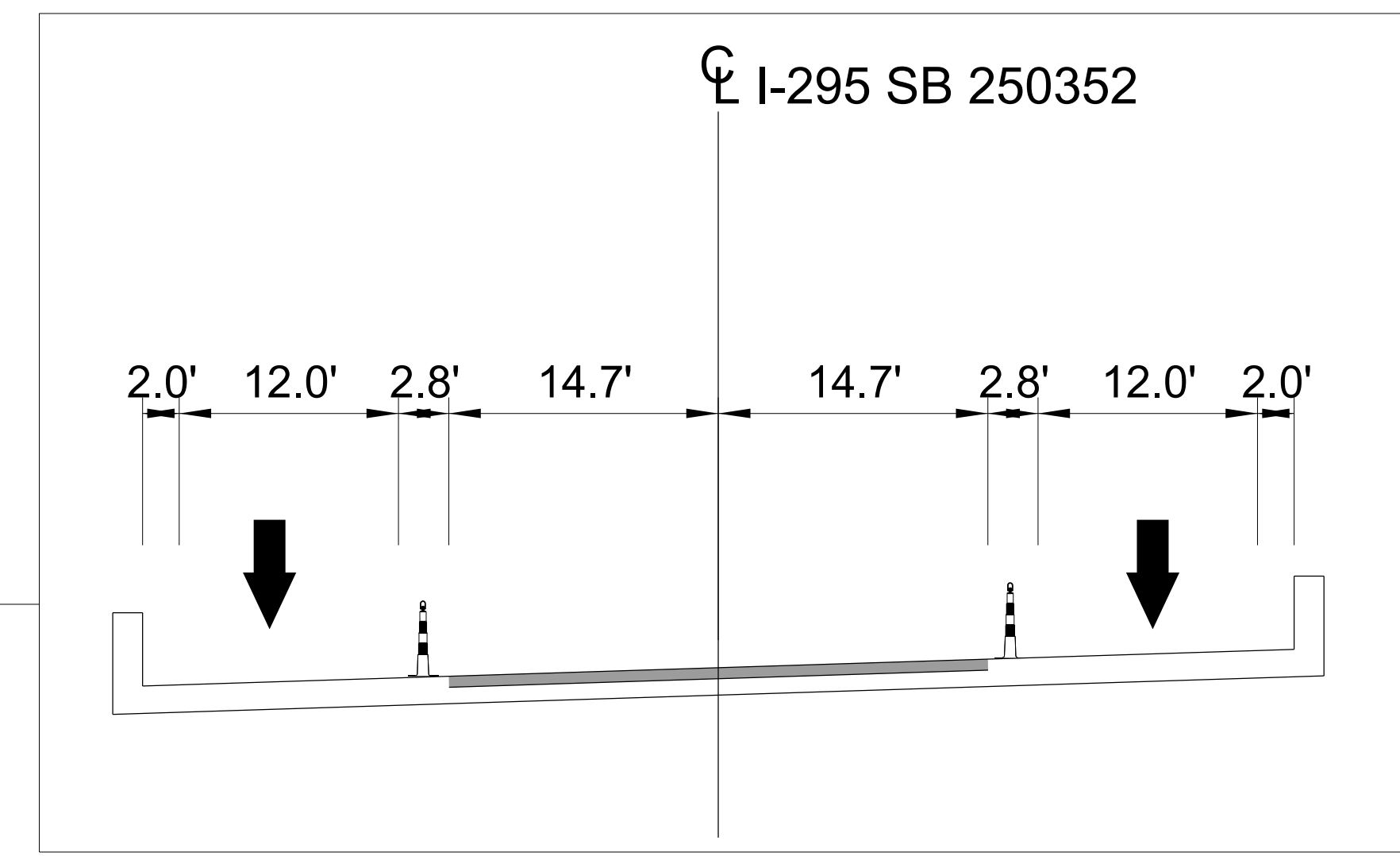

RIGHT
LANE
CLOSED

W20-5R
48"X48"

10/20/2022
U:\Traffic\Transportation Management\Plan\TCP\PLAN SHEETS\15BPR.58-TMP-13-352-PHASE.02.dgn
dorichardson

Stantec

Stantec Consulting Services Inc.
801 Jones Franklin Road
Suite 300
Raleigh, NC 27606
Tel. 919.851.6866
Fax. 919.851.7024
www.stantec.com
License No. F-0672

10/21/2022

DOCUMENT NOT CONSIDERED FINAL
UNLESS ALL SIGNATURES COMPLETED

DIVISION OF HIGHWAYS
DEPARTMENT OF TRANSPORTATION
WORK ZONE TRAFFIC CONTROL

BRIDGE 250352
PHASE II

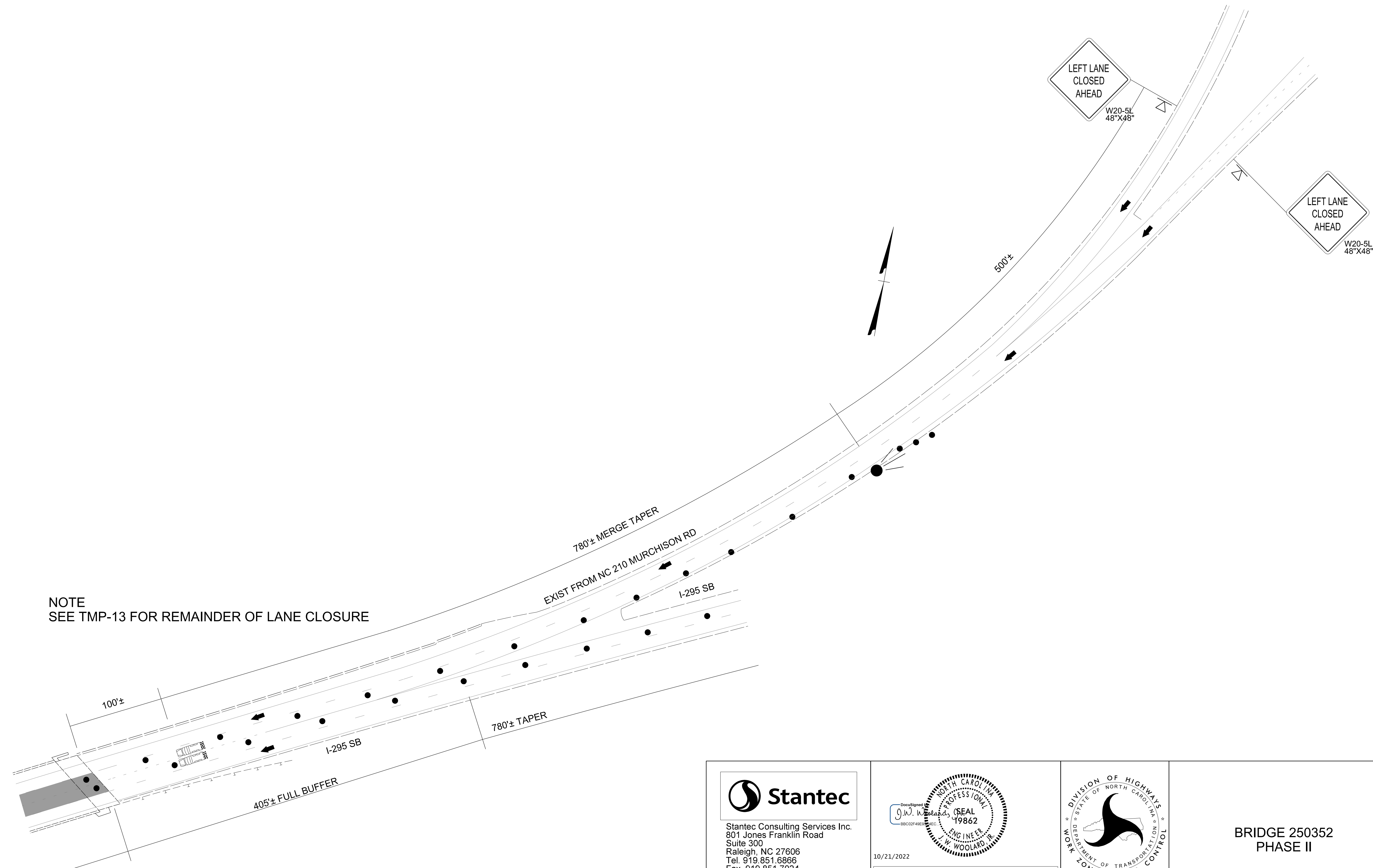

NOTE
SEE TMP-13 FOR REMAINDER OF LANE CLOSURE

10/20/2022
U:\Traffic\Transportation Management Plan\TCP\PLAN SHEETS\58BPR.58-TMP_13A_352_PHASE_02.dgn
dorichardson

Stantec Consulting Services Inc.
801 Jones Franklin Road
Suite 300
Raleigh, NC 27606
Tel. 919.851.6866
Fax. 919.851.7024
www.stantec.com
License No. F-0672

10/21/2022

DOCUMENT NOT CONSIDERED FINAL
UNLESS ALL SIGNATURES COMPLETED

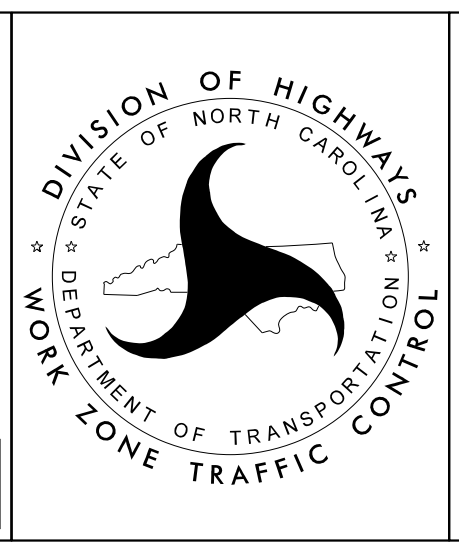

BRIDGE 250352
PHASE II

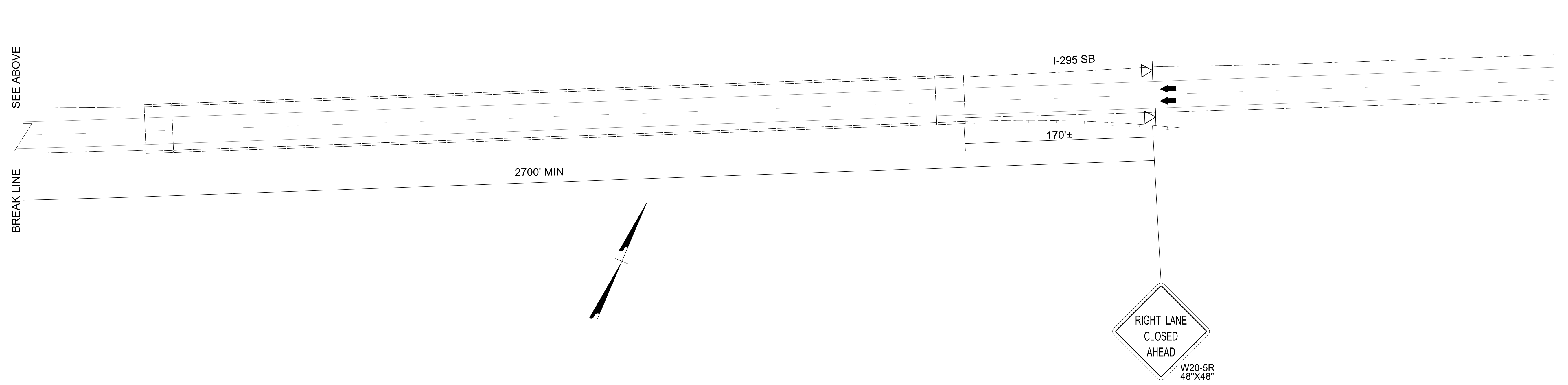
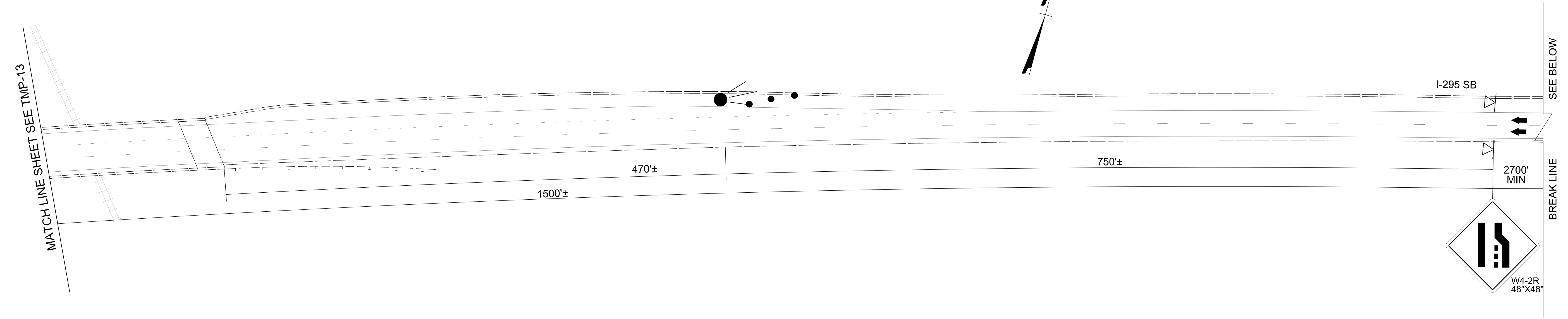

10/20/2022
U:\Traffic\Transportation Management\Plan\TCP\PLAN SHEETS\58BPR_58_TMP_14_352_PHASE_02.dgn
dorichardson

Stantec
 Stantec Consulting Services Inc.
 801 Jones Franklin Road
 Suite 300
 Raleigh, NC 27606
 Tel. 919.851.6866
 Fax. 919.851.7024
 www.stantec.com
 License No. F-0672

DocuSigned by:
 J.W. Woolard
 PROFESSIONAL SEAL
 19862
 ENGINEER
 J. W. WOOLARD, R.
 10/21/2022
**DOCUMENT NOT CONSIDERED FINAL
 UNLESS ALL SIGNATURES COMPLETED**

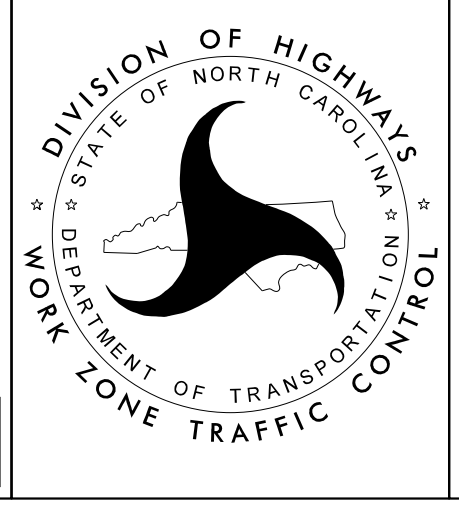

**BRIDGE 250352
PHASE II**

PROJ. REFERENCE NO.	SHEET NO.
15.BPR.58	TMP-15

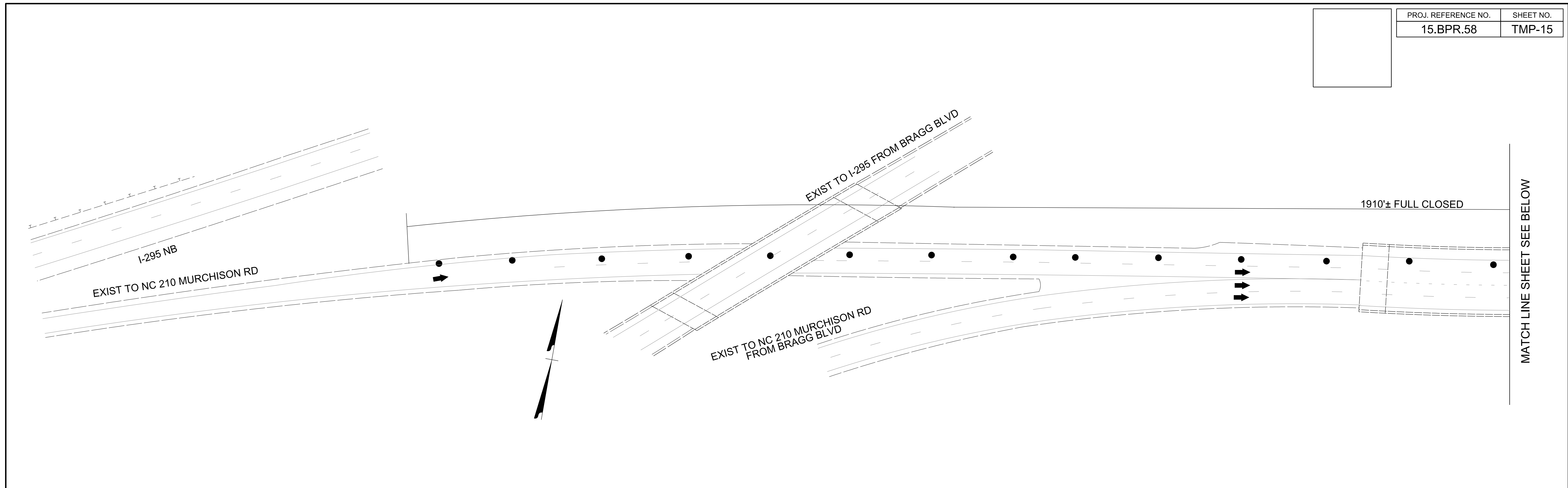

MATCH LINE SHEET SEE BELOW

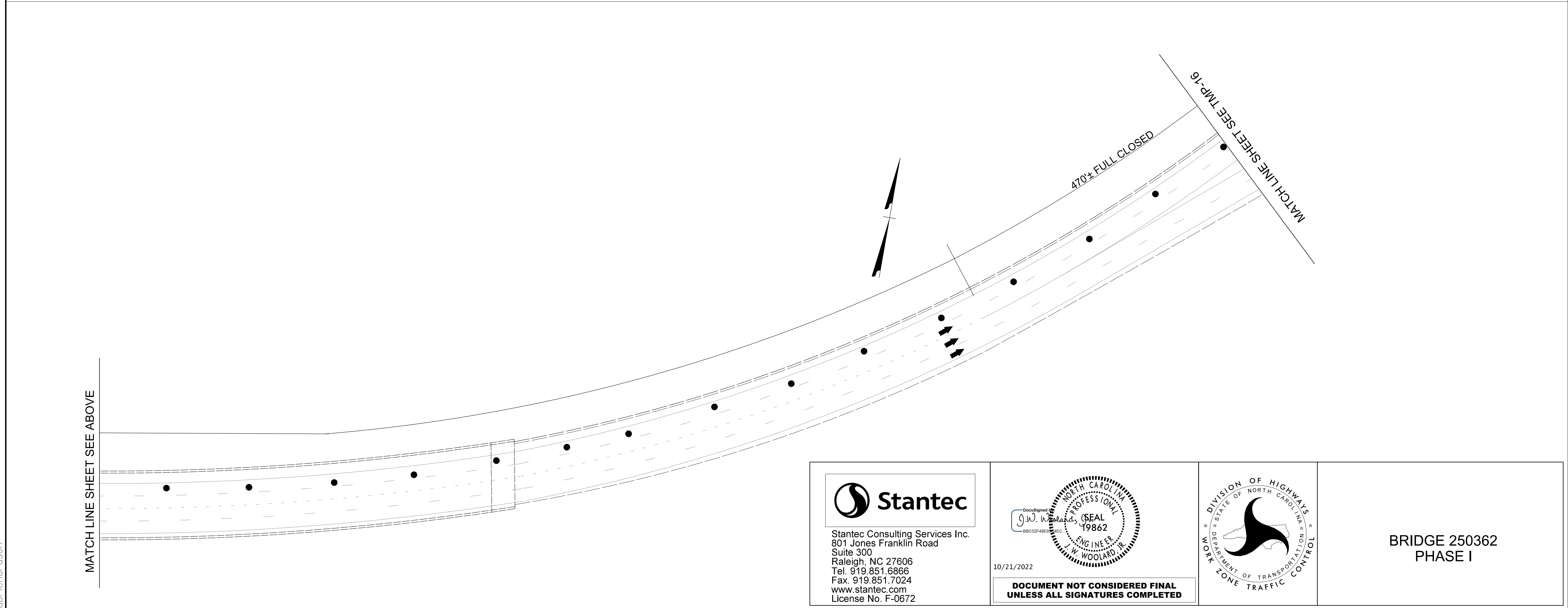

MATCH LINE SHEET SEE ABOVE

10/20/2022
U:\Traffic\Transportation Management Plan\TCP\PLAN SHEETS\15BPR.58-TMP-15-362-PHASE-01.dgn
dorichardson

Stantec
 Stantec Consulting Services Inc.
 801 Jones Franklin Road
 Suite 300
 Raleigh, NC 27606
 Tel. 919.851.6866
 Fax. 919.851.7024
 www.stantec.com
 License No. F-0672

10/21/2022
**DOCUMENT NOT CONSIDERED FINAL
 UNLESS ALL SIGNATURES COMPLETED**

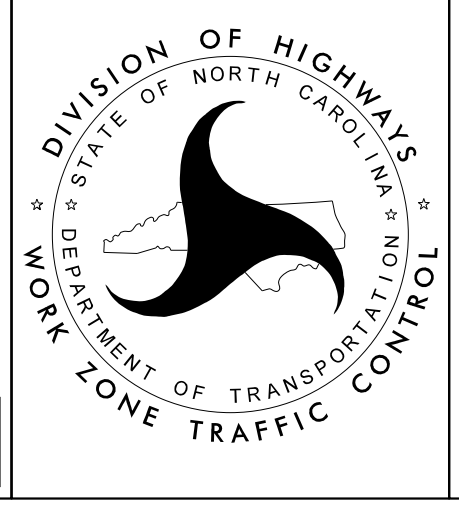
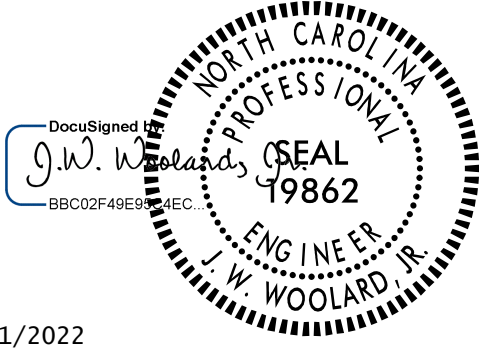

**BRIDGE 250362
 PHASE I**

PROJ. REFERENCE NO.	SHEET NO.
15.BPR.58	TMP-16

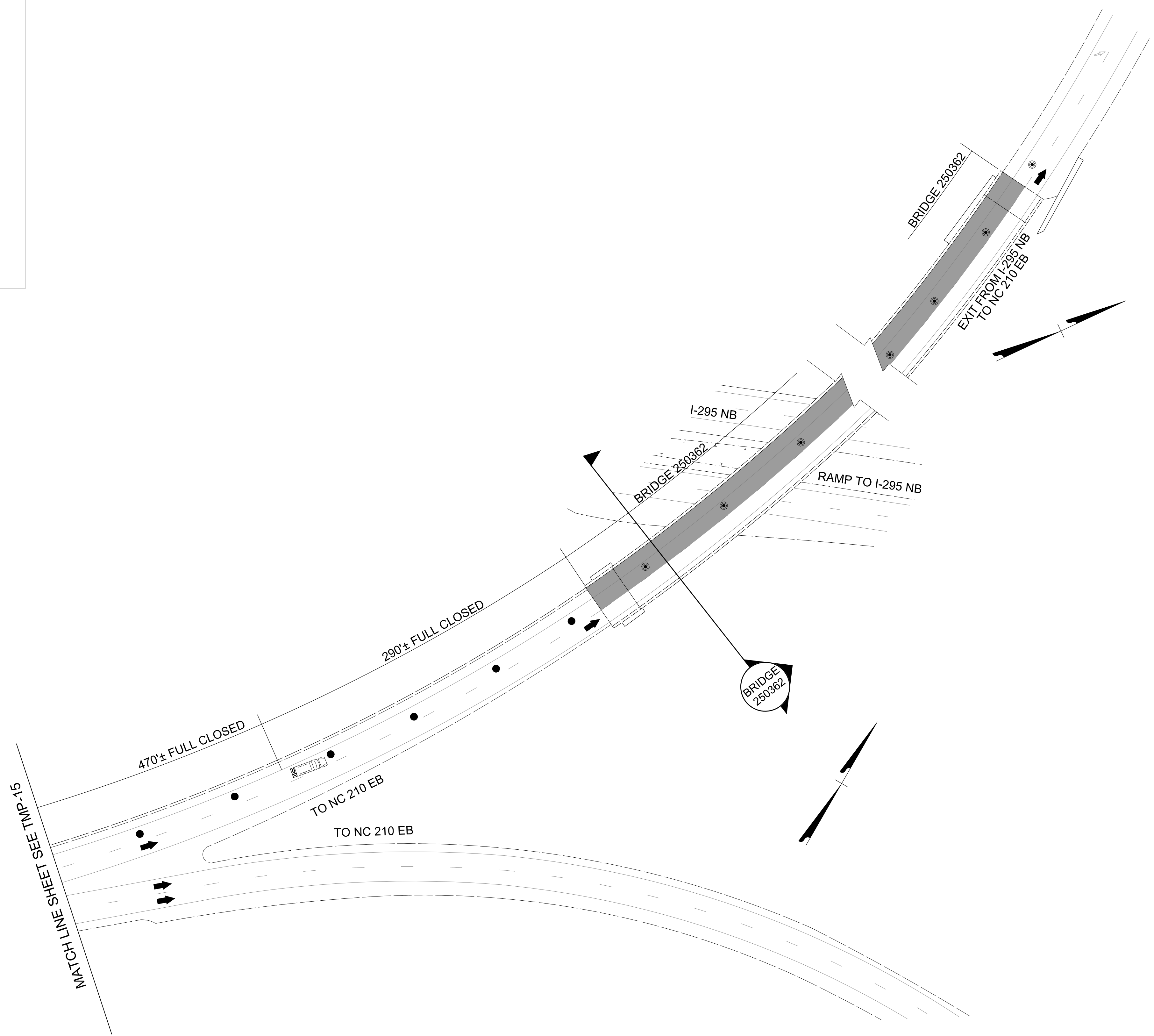
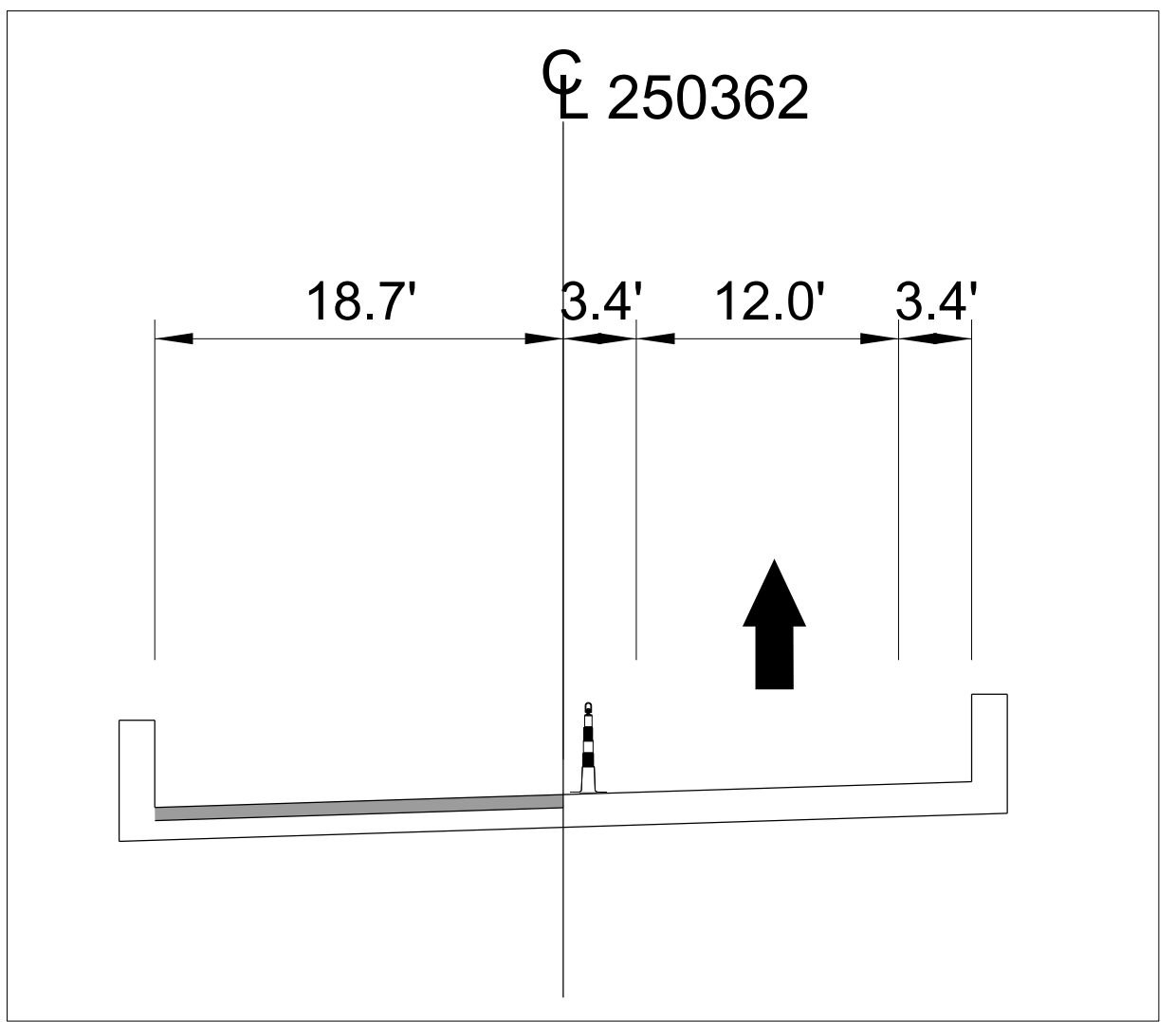

MATCH LINE SHEET SEE T.M.P. 15

10/20/2022
 U:\Traffic\Transportation Management\Plan\TCP\PLAN SHEETS\15BPR.58_TMP_16_362_PHASE_01.dgn
 dorichardson

Stantec
 Stantec Consulting Services Inc.
 801 Jones Franklin Road
 Suite 300
 Raleigh, NC 27606
 Tel. 919.851.6866
 Fax. 919.851.7024
 www.stantec.com
 License No. F-0672

10/21/2022
**DOCUMENT NOT CONSIDERED FINAL
 UNLESS ALL SIGNATURES COMPLETED**

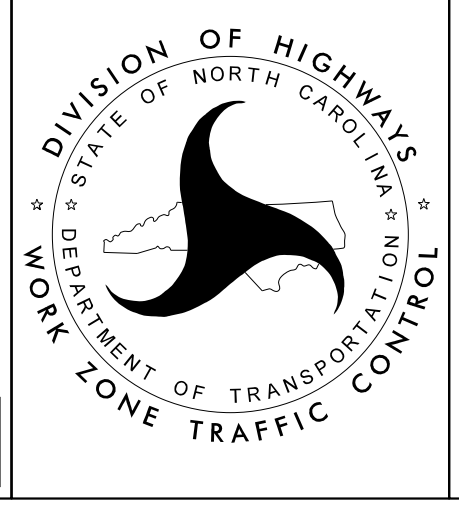

**BRIDGE 250362
 PHASE I**

North Carolina Department of Transportation logo.

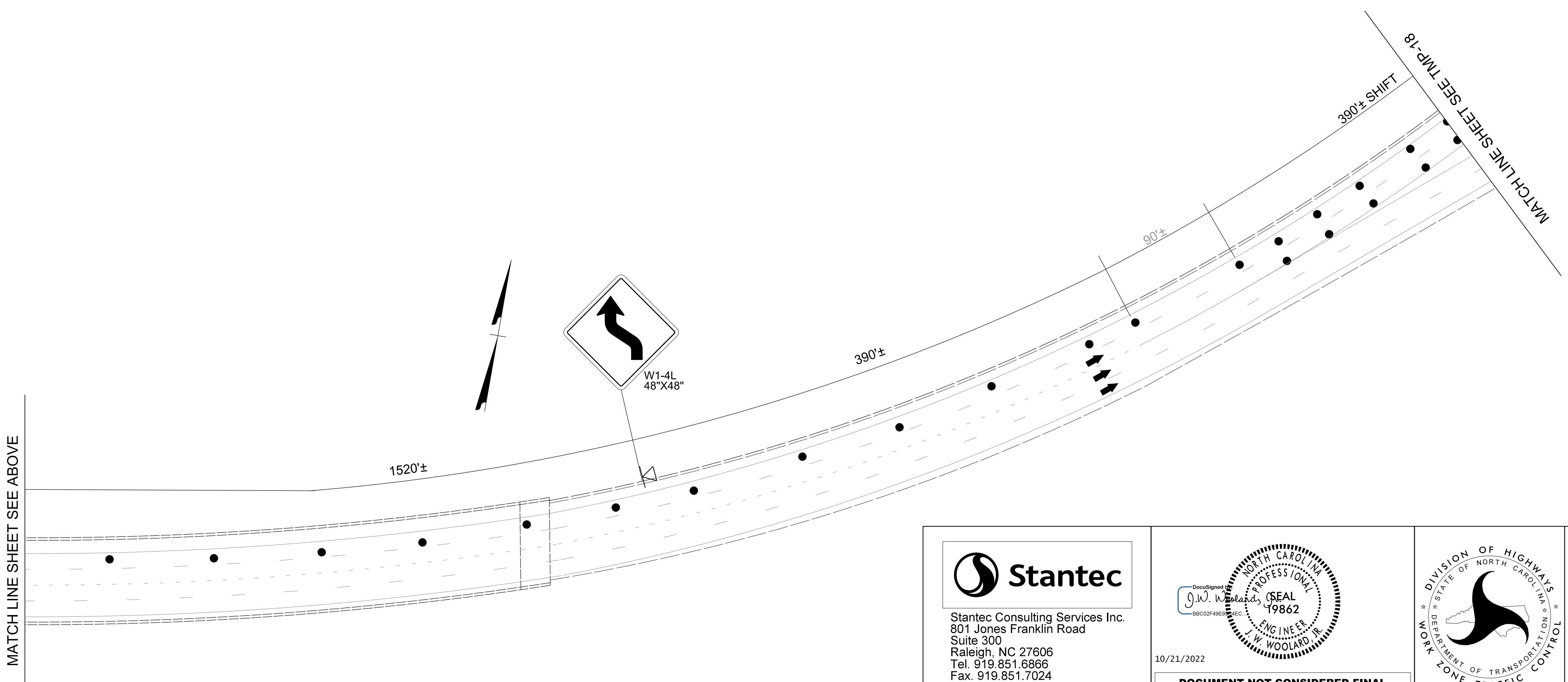
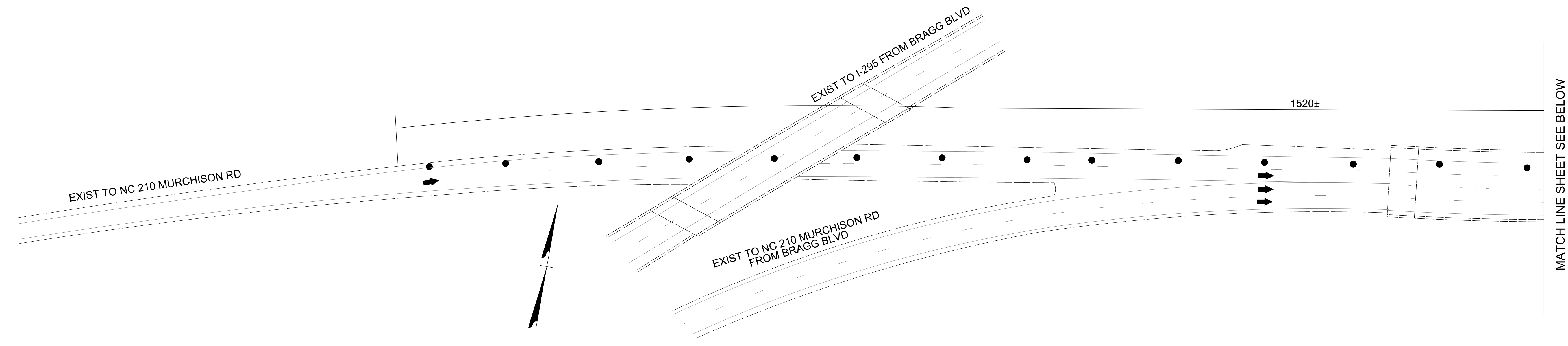

10/20/2022
U:\Traffic\Transportation Management\Plan\TCP\PLAN SHEETS\15BPR.58_TMP_17_362_PHASE_02.dgn
dorichardson

Stantec
 Stantec Consulting Services Inc.
 801 Jones Franklin Road
 Suite 300
 Raleigh, NC 27606
 Tel. 919.851.6866
 Fax. 919.851.7024
 www.stantec.com
 License No. F-0672

10/21/2022
**DOCUMENT NOT CONSIDERED FINAL
 UNLESS ALL SIGNATURES COMPLETED**

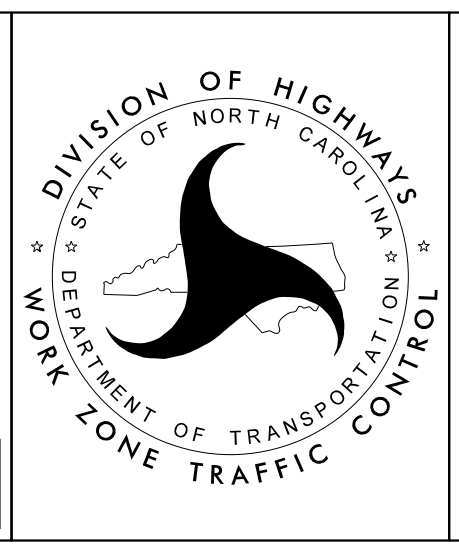

**BRIDGE 250362
 PHASE II**

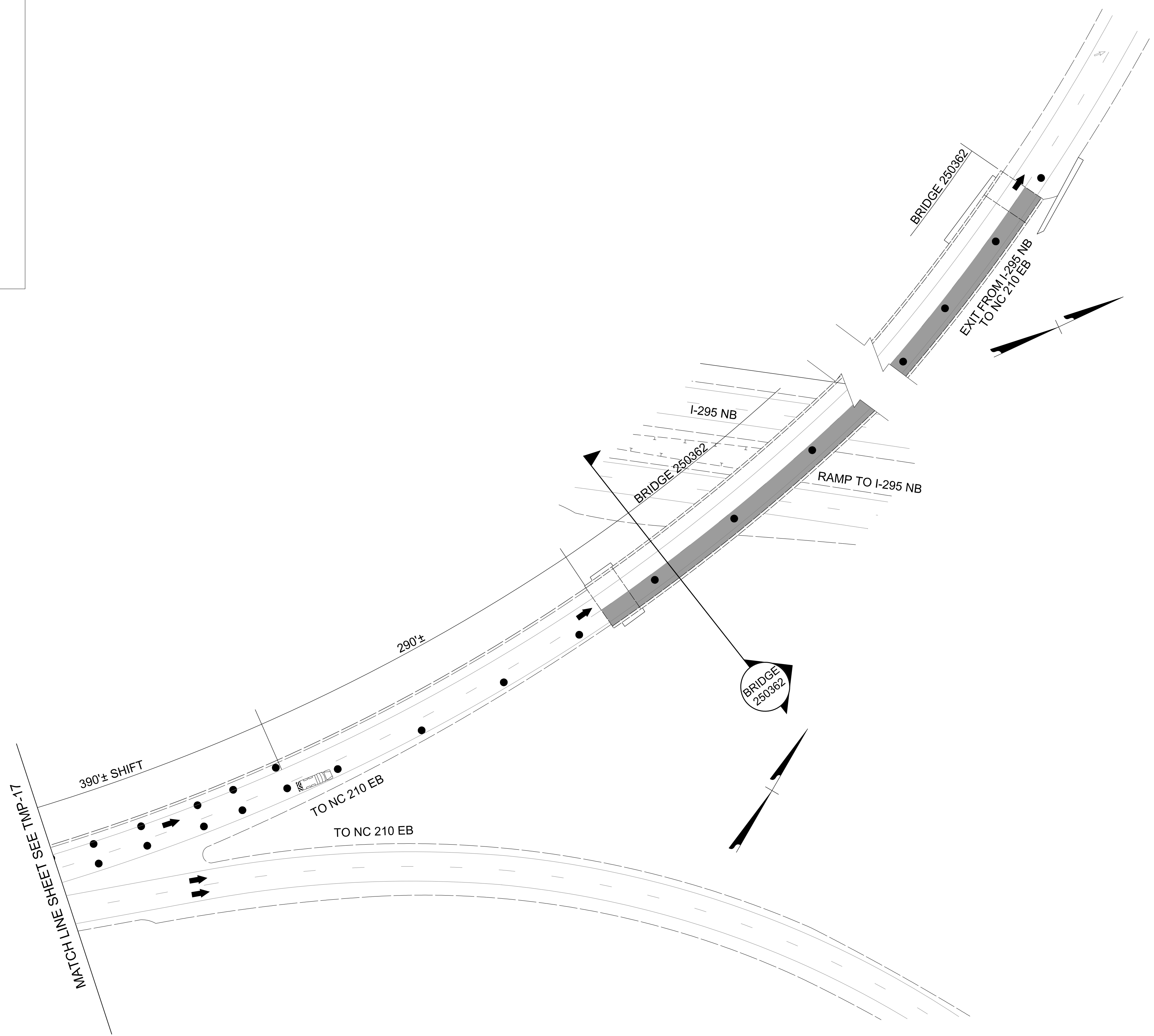
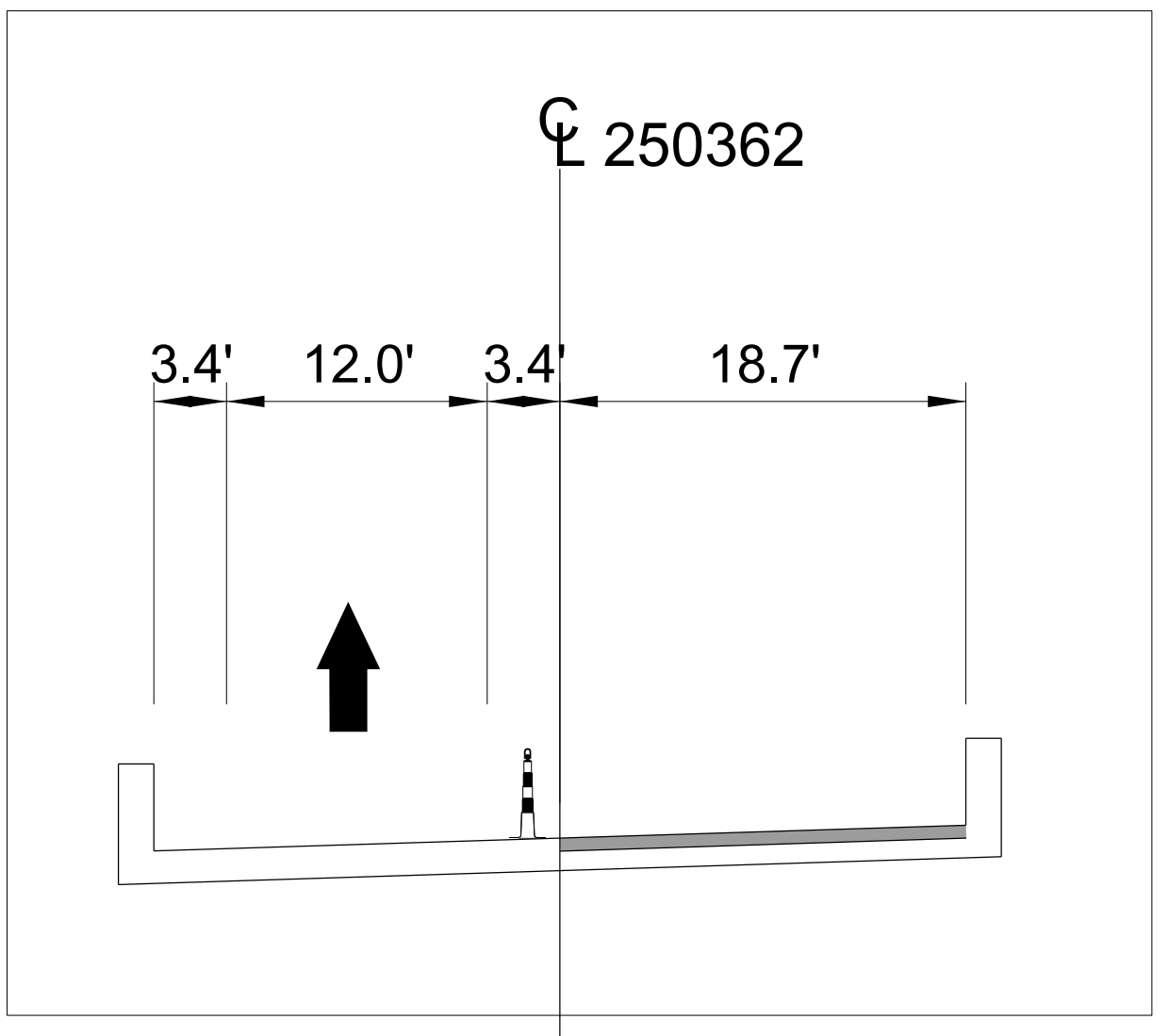

10/20/2022
 U:\Traffic\Transportation Management\Plan\TCP\PLAN SHEETS\15BPR.58_TMP_18_362_PHASE_02.dgn
 dorichardson

Stantec Consulting Services Inc.
 801 Jones Franklin Road
 Suite 300
 Raleigh, NC 27606
 Tel. 919.851.6866
 Fax. 919.851.7024
 www.stantec.com
 License No. F-0672

10/21/2022

**DOCUMENT NOT CONSIDERED FINAL
 UNLESS ALL SIGNATURES COMPLETED**

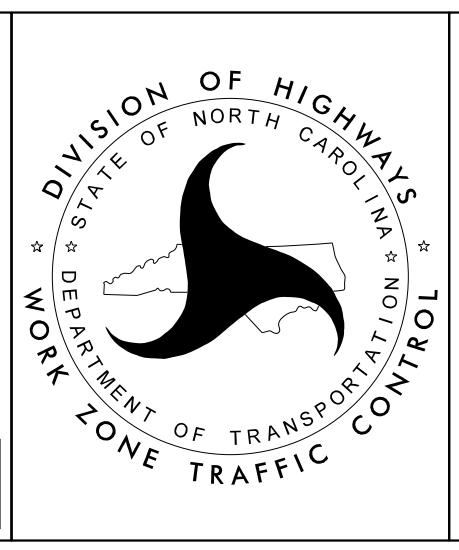

**BRIDGE 250362
 PHASE II**