

**This electronic collection of documents is provided
for the convenience of the user
and is Not a Certified Document –**

**The documents contained herein were originally issued
and sealed by the individuals whose names and license
numbers appear on each page, on the dates appearing
with their signature on that page.**

**This file or an individual page
shall not be considered a certified document.**

10/5/2022 p:\csm\smith-oz02-pw.bentley.com\FW_PL1\Documents\117240\235078\10 Transportation\04 Client Folder Structure\B-5644\Traffic\Signing\CADD\B5644_Sgn_SGN01.dgn

CONTRACT: TIP PROJECT: B-5644

STATE OF NORTH CAROLINA DEPARTMENT OF TRANSPORTATION

SIGNING PLAN PENDER COUNTY

LOCATION: REPLACE BRIDE NO.15 OVER CROOKED RUN ON NC 11

<small>PROJECT REFERENCE NO.</small> B-5644	<small>SHEET NO.</small> SIGN-1
<small>DocuSigned by:</small> <i>Adam M. Conrad</i>	
<small>APPROVED:</small>	
<small>DATE:</small> 10/5/2022	
DOCUMENT NOT CONSIDERED FINAL UNLESS ALL SIGNATURES COMPLETED	
<small>CDM Smith Inc. 5400 Glenwood Avenue Suite 400 Raleigh, NC 27612-3228 NC COA No. F-1255</small>	

SUMMARY OF QUANTITIES

ITEM NO.		ITEM DESCRIPTION	QUANTITY	UNIT
DESC. NO.	SECT. NO.			
4072000000	903	SUPPORTS, 3 LB STEEL U-CHANNEL	20	L.F.
4116100000	904	SIGN ERECTION, RELOCATE TYPE E (GROUND MOUNTED)	2	EA.
4155000000	907	DISPOSAL OF SIGN SYSTEM, U-CHANNEL	4	EA.

ROADWAY STANDARD DRAWING

THE FOLLOWING ROADWAY STANDARDS AS APPEAR IN "ROADWAY STANDARD DRAWINGS" - N.C. DEPARTMENT OF TRANSPORTATION - RALEIGH, N.C., DATED JANUARY 2018 ARE APPLICABLE TO THIS PROJECT AND BY REFERENCE HEREBY ARE CONSIDERED A PART OF THESE PLANS:

<u>STD. NO.</u>	<u>TITLE</u>
904.10	ORIENTATION OF GROUND MOUNTED SIGNS
904.50	MOUNTING OF TYPE 'D', 'E' AND 'F' SIGNS ON 'U' CHANNEL POSTS

GENERAL NOTES

- . SIGNS FURNISHED BY STATE
- . CONFIRM IN WRITING AT LEAST 4 MONTHS IN ADVANCE, THE ACTUAL DATE THE DEPARTMENT FURNISHED SIGNS WILL BE REQUIRED.
- . SEE ROADWAY PLANS FOR GUARD/GUIDE RAIL DETAILS.
- . IF REMOVAL OR RELOCATION OF SIGNS ON PRIVATE STREET (NON-STATE MAINTAINED) IS REQUIRED DUE TO CONSTRUCTION, THE CONTRACTOR SHALL INFORM THE ENGINEER. THE WORK WILL BE COMPLETED BY OTHERS.
- . ALL EXISTING SIGNS ON "U" CHANNEL POST WITHIN THE PROJECT LIMITS SHALL BE REMOVED AND DISPOSED OF UNLESS OTHERWISE NOTED ON PLANS.
- . WHEN EXISTING SIGNS ARE REMOVED AND INSTALLED ON NEW SUPPORTS, THE RE-ERECTION SHALL IMMEDIATELY FOLLOW THE REMOVAL.

PLAN PREPARED BY: CDM SMITH, INC.

DAVID Z. KEISER, P. E. PROJECT MANAGER
ADAM M. CONRAD, P. E. PROJECT DESIGN ENGINEER

CDM Smith Inc.
5400 Glenwood Avenue
Suite 400
Raleigh, NC 27612-3228
NC COA No. F-1255

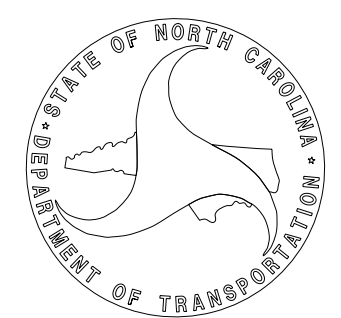

PLAN PREPARED FOR: N.C.D.O.T. SIGNING AND DELINEATION UNIT

AYMAN ALQUDWAH, P.E. SIGNING & DELINEATION REGIONAL ENGINEER
MITCH EATON, P.E. SIGNING & DELINEATION PROJECT DESIGN ENGINEER

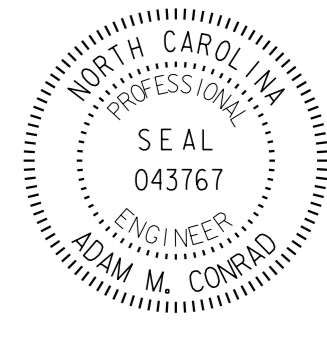

INDEX

<u>SHEET NO.</u>	<u>DESCRIPTION</u>
SIGN-1	TITLE SHEET
SIGN-2	EXISTING AND PROPOSED SIGN

TIP NO.	SHEET NO.
B-5644	SIGN-2
Approved by: <i>Aden M. Conrad</i> <small>DESIGNED BY</small> DATE: 3/23/2022	
SEAL 	
DOCUMENT NOT CONSIDERED FINAL UNLESS ALL SIGNATURES COMPLETED	
 CDM Smith Inc. 5400 Glenwood Avenue Suite 400 Raleigh, NC 27612-3228 NC COA No. F-1255	

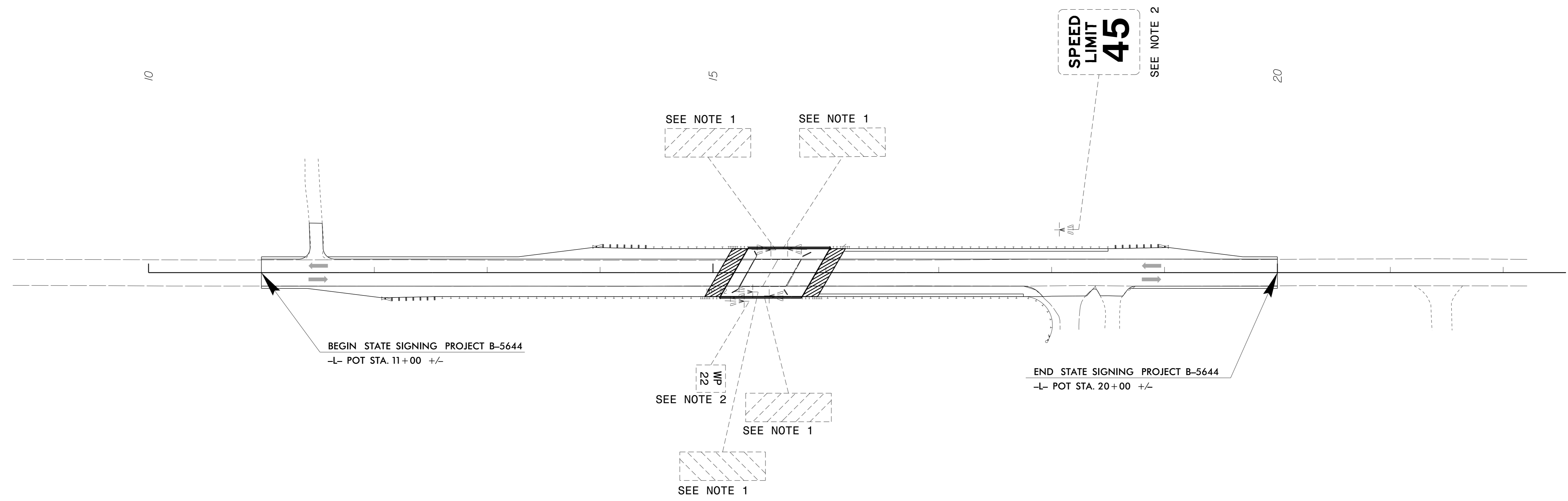

NOTE: FOR PROPOSED WIDENING ALONG THE DETOUR ROUTE, SHOWN ON SHEETS 2B-1 THRU 2B-3 IN THE ROADWAY PLANS, ALL EXISTING SIGNS THAT ARE IMPACTED BY CONSTRUCTION ACTIVITIES SHALL BE RELOCATED IN THE FIELD AS DIRECTED BY THE ENGINEER.

- NOTES:
- 1 DISPOSAL OF SIGN SYSTEM, U-CHANNEL
 - 2 RELOCATE SIGN, TYPE E

EXISTING AND PROPOSED SIGNS

3/23/2022
 pwa\cdmsmith-az02-pw.bentley.com\FW_PLI\Documents\IT240\235078\0 Transportation\04 Client Folder Structure\B-5644\Traffic\Signing\CADD\B5644_Sgn_SGN02.dgn
 User:CONRADAM