

NOTES

STIRRUPS IN CAP MAY BE SHIFTED AS NECESSARY TO CLEAR DOWELS.

THE CONCRETE IN THE SHADED AREA OF THE WING SHALL BE POURED AFTER THE VERTICAL CONCRETE BARRIER RAIL IS CAST IF SLIP FORMING IS USED.

FOR PILE SPLICE DETAILS, SEE SHEET 4 OF 4.

FOR WING DETAILS, SEE SHEET 3 OF 4.

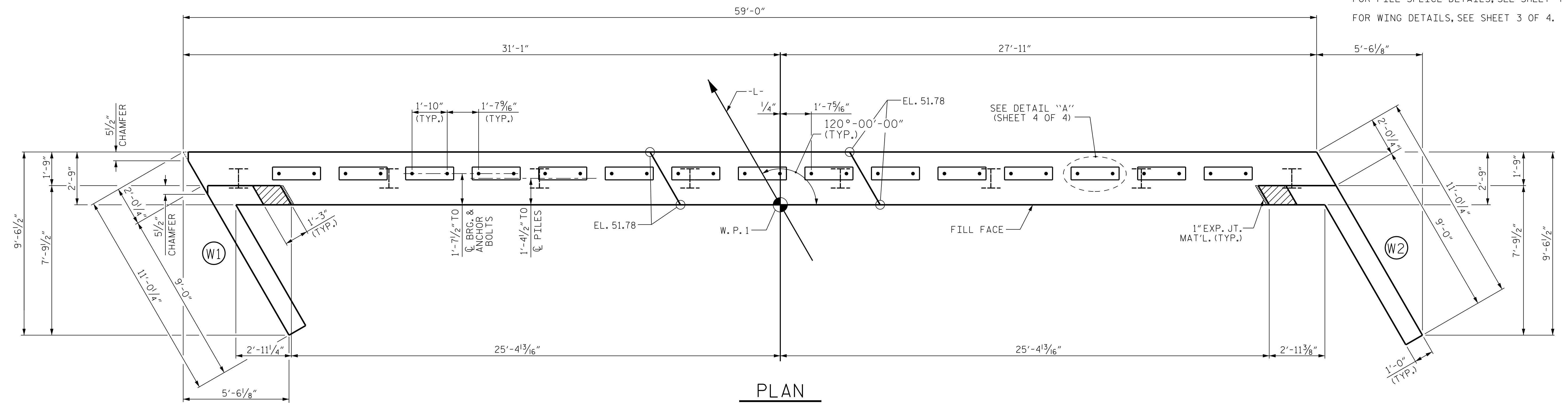

PLAN

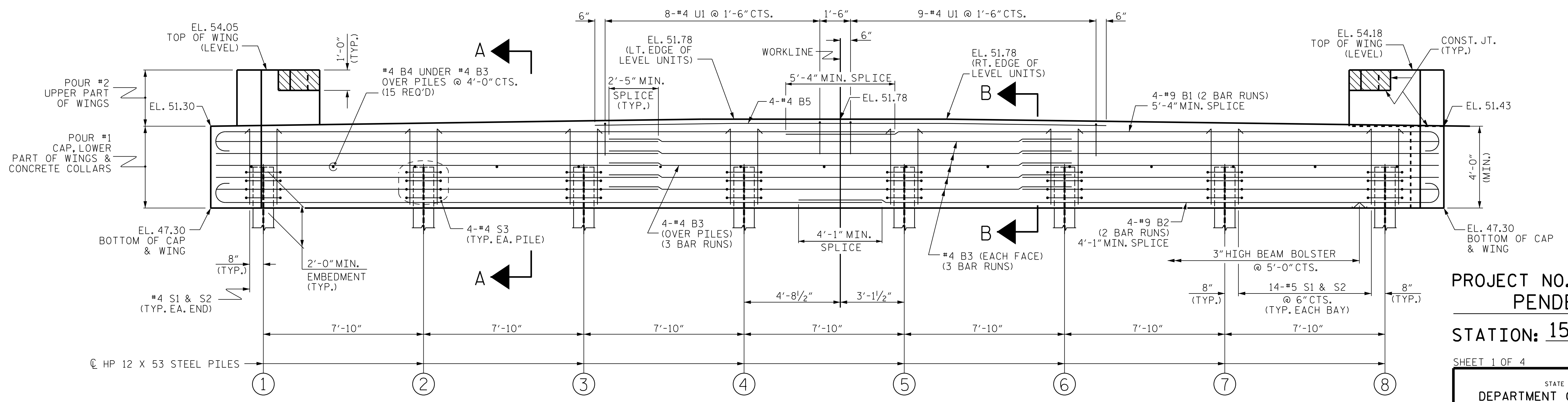

ELEVATION

WINGS NOT SHOWN FOR CLARITY. FOR SECTION A-A, SEE SHEET 4 OF 4.
 CONCRETE COLLARS FOR STEEL PILES NOT SHOWN IN PLAN AND ELEVATION VIEWS FOR CLARITY. SEE "CORROSION PROTECTION FOR STEEL PILES DETAIL", SHEET 4 OF 4.

PROJECT NO. B-5644
 PENDER COUNTY
 STATION: 15+55.00 -L-

SHEET 1 OF 4

STATE OF NORTH CAROLINA
 DEPARTMENT OF TRANSPORTATION
 RALEIGH
 SUPERSTRUCTURE

END BENT 1

DOCUMENT NOT CONSIDERED
 FINAL UNLESS ALL
 SIGNATURES COMPLETED

CDM Smith
 CDM SMITH
 5400 Glenwood Avenue, Suite 400
 Raleigh, NC 27612-3228
 NC COA No. F-1255

DRAWN BY: VDK DATE: 5/19
 CHECKED BY: THF DATE: 4/20
 DESIGN ENGINEER: VDK DATE: 5/20

DWG. No.

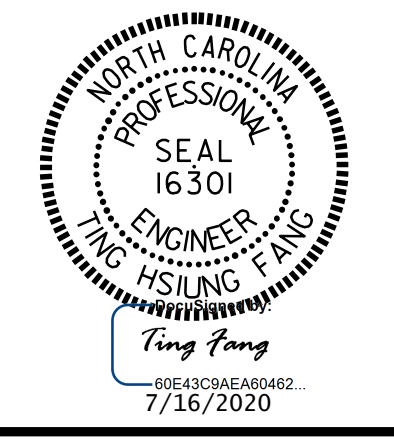

REVISIONS				SHEET NO.	
NO.	BY:	DATE:	NO.	BY:	DATE:
1			3		
2			4		

TOTAL SHEETS: 19

FILE: c:\pwworking\16154831\d01_007_B5644_SXU_ET_014.dgn
 DATE: 7/15/2020 10:26:54 AM