

3/23/2022  
pwa\cdmsmith-az02-pw.bentley.com\FW\_PLI\Documents\17240\235078\0 Transportation\04 Client Folder Structure\B-5644\Traffic\Signing\CADD\B5644\_Sgn\_SGN02.dgn  
User:CONRADAM

TIP NO. <b>B-5644</b>	SHEET NO. <b>SIGN-2</b>
DESIGNED BY: <i>Aden M. Conrad</i> APPROVED: _____ <small>(Signature)</small> DATE: 3/23/2022	
SEAL 	
<b>DOCUMENT NOT CONSIDERED FINAL UNLESS ALL SIGNATURES COMPLETED</b>	
<b>CDM Smith</b> <small>CDM Smith Inc. 5400 Glenwood Avenue Suite 400 Raleigh, NC 27612-3228 NC COA No. F-1255</small>	

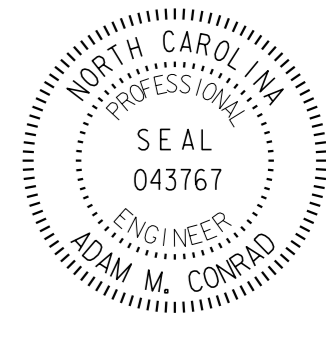
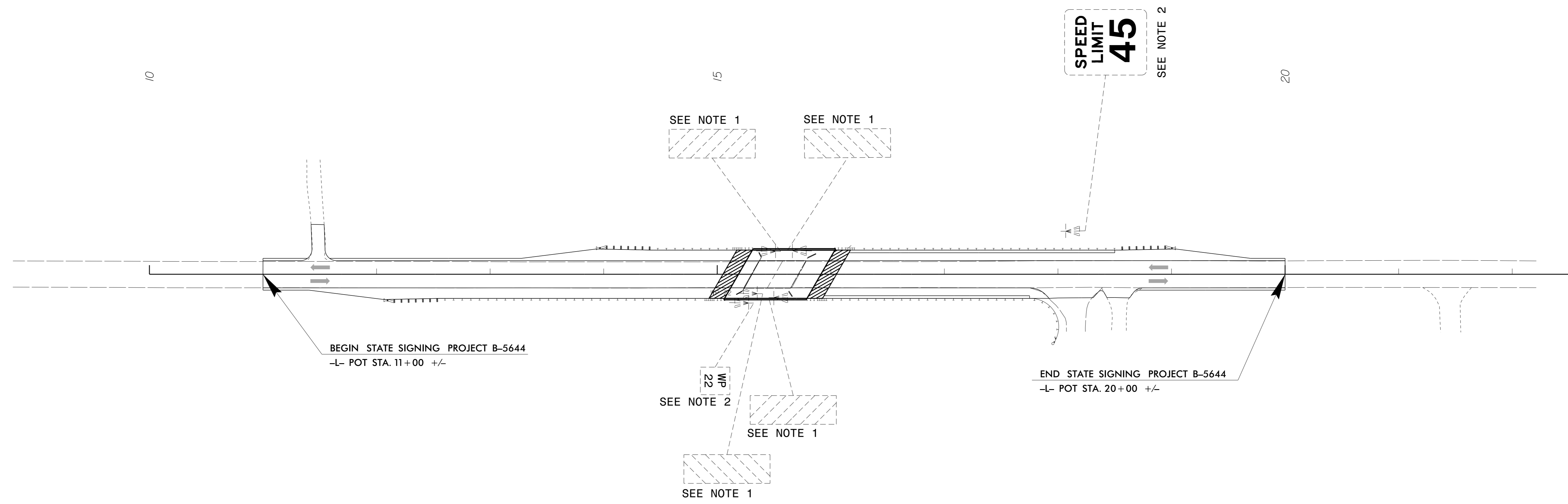

NOTE: FOR PROPOSED WIDENING ALONG THE DETOUR ROUTE, SHOWN ON SHEETS 2B-1 THRU 2B-3 IN THE ROADWAY PLANS, ALL EXISTING SIGNS THAT ARE IMPACTED BY CONSTRUCTION ACTIVITIES SHALL BE RELOCATED IN THE FIELD AS DIRECTED BY THE ENGINEER.

- NOTES:
- 1 DISPOSAL OF SIGN SYSTEM, U-CHANNEL
  - 2 RELOCATE SIGN, TYPE E

**EXISTING AND PROPOSED SIGNS**