

T.I.P.: A-0009CC

**STATE OF NORTH CAROLINA
DEPARTMENT OF TRANSPORTATION**

**PAVEMENT MARKING PLAN
GRAHAM COUNTY**

**LOCATION: NC 143 FROM 0.5 MI NORTH OF APPALACHIAN TRAIL TO NC 28
NC 28 FROM 0.2 MI WEST OF NC 143 TO 0.2 MI WEST OF SR 1228 (STECOAH RD)**

<small>TIP NO.</small> A-0009CC	<small>SHEET NO.</small> PMP-1
<small>APPROVED:</small> <small>DATE:</small> 10/18/2022	
<small>DOCUMENT NOT CONSIDERED FINAL UNLESS ALL SIGNATURES COMPLETED</small>	

INDEX

<u>SHEET NO.</u>	<u>DESCRIPTION</u>
PMP-1	PAVEMENT MARKING PLAN TITLE, INDEX OF SHEETS, LIST OF APPLICABLE ROADWAY STANDARD DRAWINGS, GENERAL NOTES AND FINAL PAVEMENT MARKING SCHEDULE
PMP-1A	REVISED PAVEMENT MARKING RDY STD 1205.04 SHEET 2 OF 2
PMP-2 THRU PMP-7	PAVEMENT MARKING DETAIL

GENERAL NOTES

THE FOLLOWING GENERAL NOTES APPLY AT ALL TIMES FOR THE DURATION OF THE CONSTRUCTION PROJECT, EXCEPT WHEN OTHERWISE NOTED IN THE PLAN, OR DIRECTED BY THE ENGINEER.

A) INSTALL PAVEMENT MARKINGS AND PAVEMENT MARKERS ON THE FINAL SURFACE AS FOLLOWS:

<u>ROAD NAME</u>	<u>MARKING</u>	<u>MARKER</u>
NC 143 -L-	}	NON-CAST IRON SNOWPLOWABLE
NC 28 -Y2-		THERMOPLASTIC
SR 1226 STECOAH RD	THERMOPLASTIC	NONE

B) TIE PROPOSED PAVEMENT MARKING LINES TO EXISTING PAVEMENT MARKING LINES.

C) REMOVE/REPLACE ANY CONFLICTING/DAMAGED PAVEMENT MARKINGS AND MARKERS.

D) STOP BAR LOCATION AT NON-SIGNALIZED INTERSECTIONS MAY BE ADJUSTED AS DIRECTED BY THE ENGINEER.

E) UNLESS OTHERWISE SPECIFIED, HEATED-IN-PLACE THERMOPLASTIC MAY BE USED IN LIEU OF EXTRUDED THERMOPLASTIC FOR STOP BARS, SYMBOLS, CHARACTERS AND DIAGONALS. IF HEATED-IN-PLACE IS USED, IT SHALL BE PAID FOR USING THE EXTRUDED THERMOPLASTIC PAY ITEM.

F) SEE ROADWAY PLANS FOR ALTERNATE CURB RAMP DESIGNS WHEN INDICATED ON PAVEMENT MARKING DETAIL SHEETS.

FINAL PAVEMENT MARKING SCHEDULE

<u>SYMBOL</u>	<u>DESCRIPTION</u>
PAVEMENT MARKINGS	
THERMOPLASTIC (4", 90 MILS)	
T1	(4") WHITE EDGELINE
T2	(4") WHITE SOLID LANE LINE
T3	(4") 10 FT. WHITE SKIP
T4	(4") 3 FT. - 9 FT./SP WHITE MINISKIP
T5	(4") 2 FT. - 6 FT./SP WHITE MINISKIP
T10	(4") YELLOW EDGELINE
T13	(4") YELLOW DOUBLE CENTER
THERMOPLASTIC (8", 90 MILS)	
T43	(8") WHITE SOLID LANE LINE
T44	(8") 3 FT. - 9 FT./SP WHITE MINISKIP
THERMOPLASTIC (12", 90 MILS)	
T52	(12") YELLOW DIAGONAL
THERMOPLASTIC (24", 90 MILS)	
T61	WHITE STOPBAR (24", 90 MIL)
THERMOPLASTIC PAVEMENT MARKING SYMBOLS (90 MILS)	
T70	LEFT TURN ARROW
T71	RIGHT TURN ARROW
THERMOPLASTIC PAVEMENT MARKING CHARACTER (90 MILS)	
T100	ALPHANUMERIC CHAR. (90 MIL)

ROADWAY STANDARD DRAWING

THE FOLLOWING ROADWAY STANDARDS AS APPEAR IN "ROADWAY STANDARD DRAWINGS" - PROJECT SERVICES UNIT - N.C. DEPARTMENT OF TRANSPORTATION - RALEIGH, N.C., DATED JANUARY 2018 ARE APPLICABLE TO THIS PROJECT AND BY REFERENCE HEREBY ARE CONSIDERED A PART OF THESE PLANS:

<u>STD. NO.</u>	<u>TITLE</u>
1205.01	PAVEMENT MARKINGS - LINE TYPES AND OFFSETS
1205.02	PAVEMENT MARKINGS - TWO-LANE AND MULTILANE ROADWAYS
1205.04	PAVEMENT MARKINGS - INTERSECTIONS
1205.05	PAVEMENT MARKINGS - TURN LANES
1205.06	PAVEMENT MARKINGS - LANE DROPS
1205.08	PAVEMENT MARKINGS - SYMBOLS AND WORD MESSAGES
1205.09	PAVEMENT MARKINGS - PAINTED ISLANDS
1250.01	RAISED PAVEMENT MARKERS - INSTALLATION SPACING
1253.01	RAISED PAVEMENT MARKERS - SNOWPLOWABLE
1261.01	GUARDRAIL AND BARRIER DELINEATORS - INSTALLATION SPACING
1261.02	GUARDRAIL AND BARRIER DELINEATORS - TYPES AND MOUNTING
1262.01	GUARDRAIL END DELINEATION

PLAN SUBMITTED TO: NCDOT DIVISION 14

WANDA H. AUSTIN, PE DIVISION ENGINEER

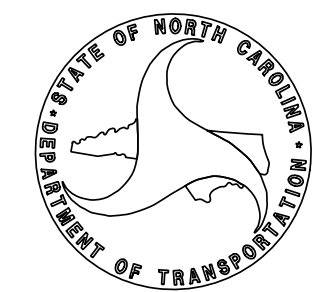

PLAN PREPARED BY: TGS ENGINEERS

JIMMY TERRY, PE PROJECT ENGINEER
SANDRA MELVIN DESIGN TECHNICIAN

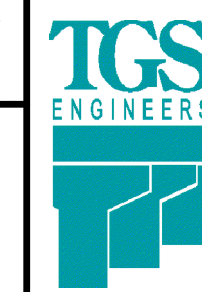

TGS ENGINEERS
201 W. MARION ST
SHELBY, NC 28150
PH (704) 476-0003
CORP. LICENSE NO.: C-0275

TIP NO.	SHEET NO.
DocuSigned by:	
APPROVED:	<i>Matthew V. Springer</i>
DATE:	8/13/2019
SEAL	

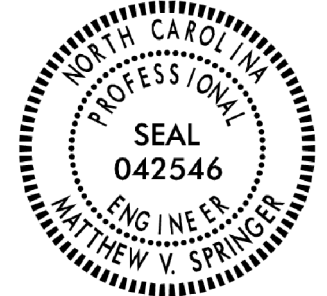
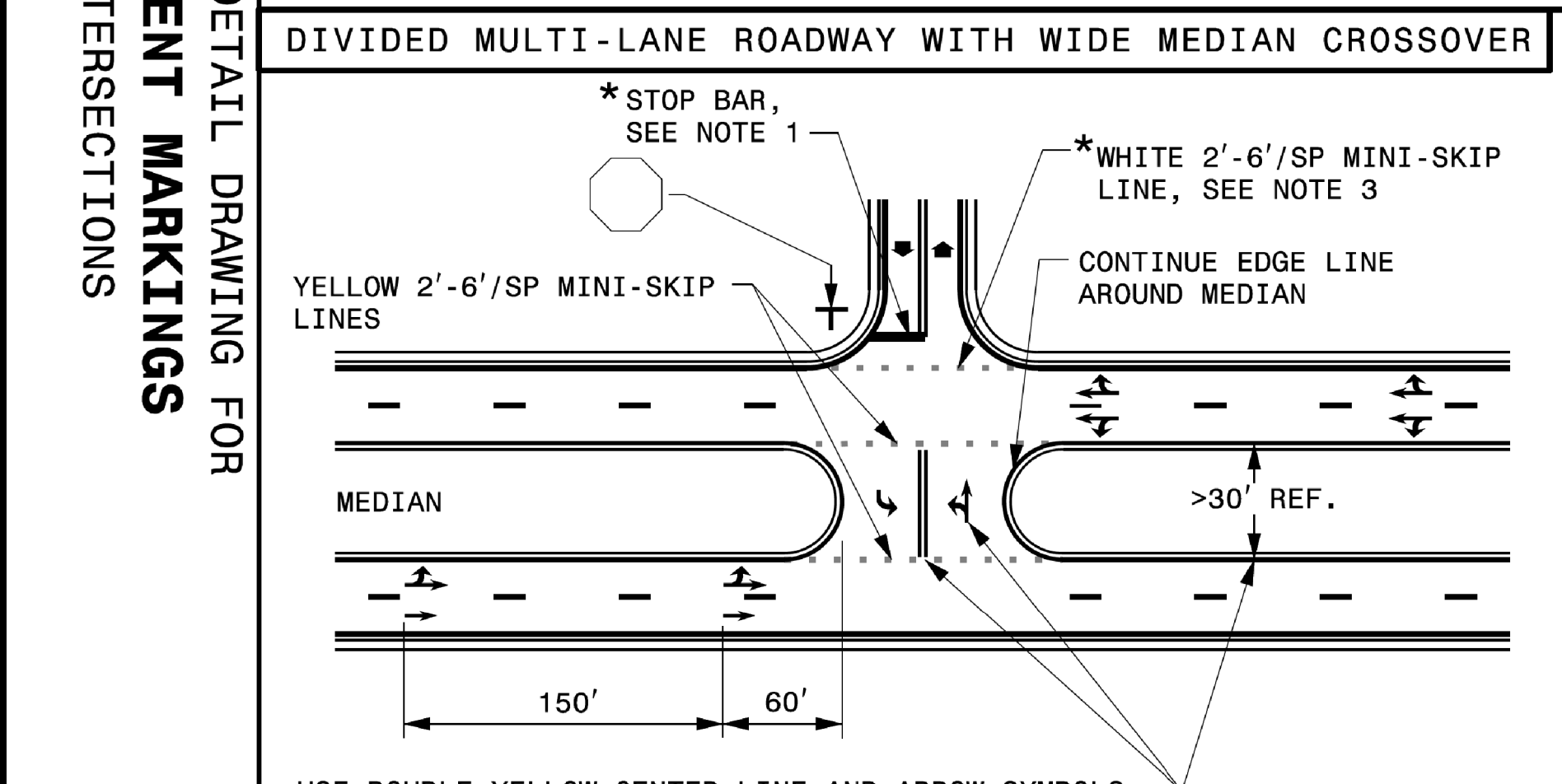
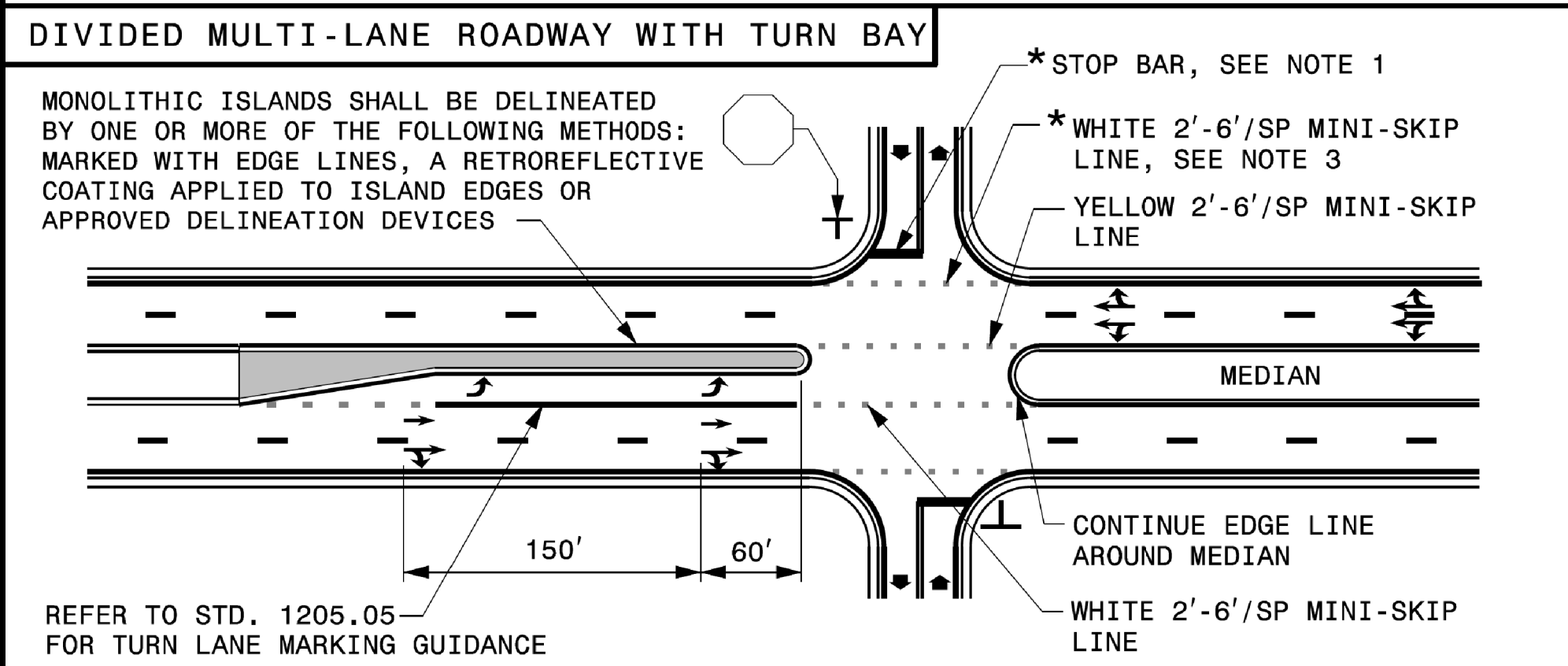
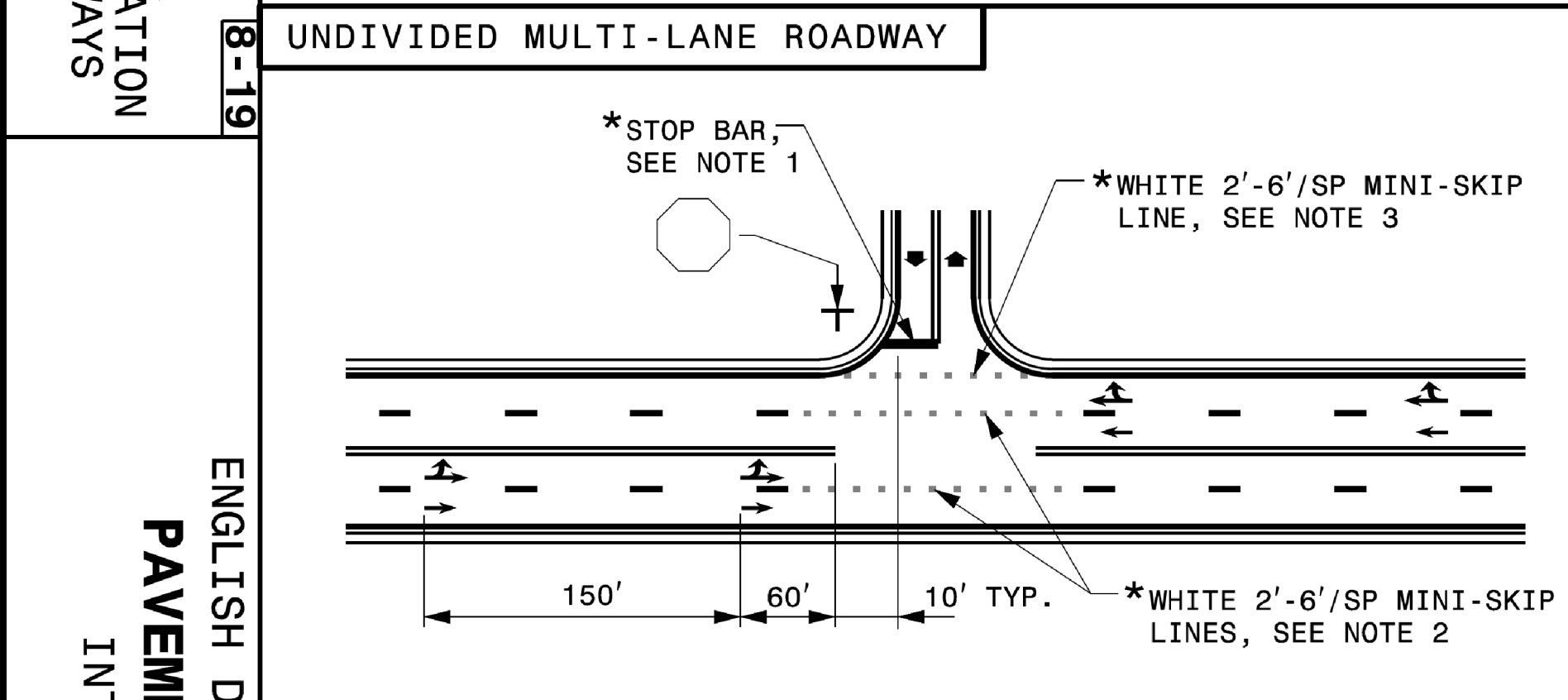
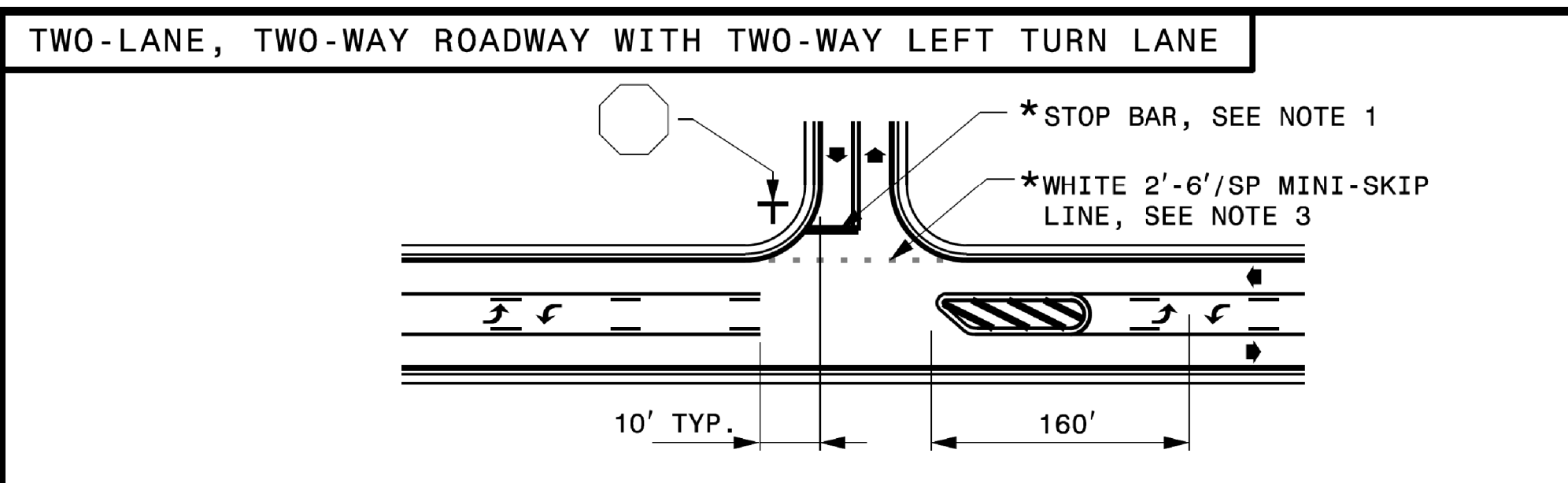
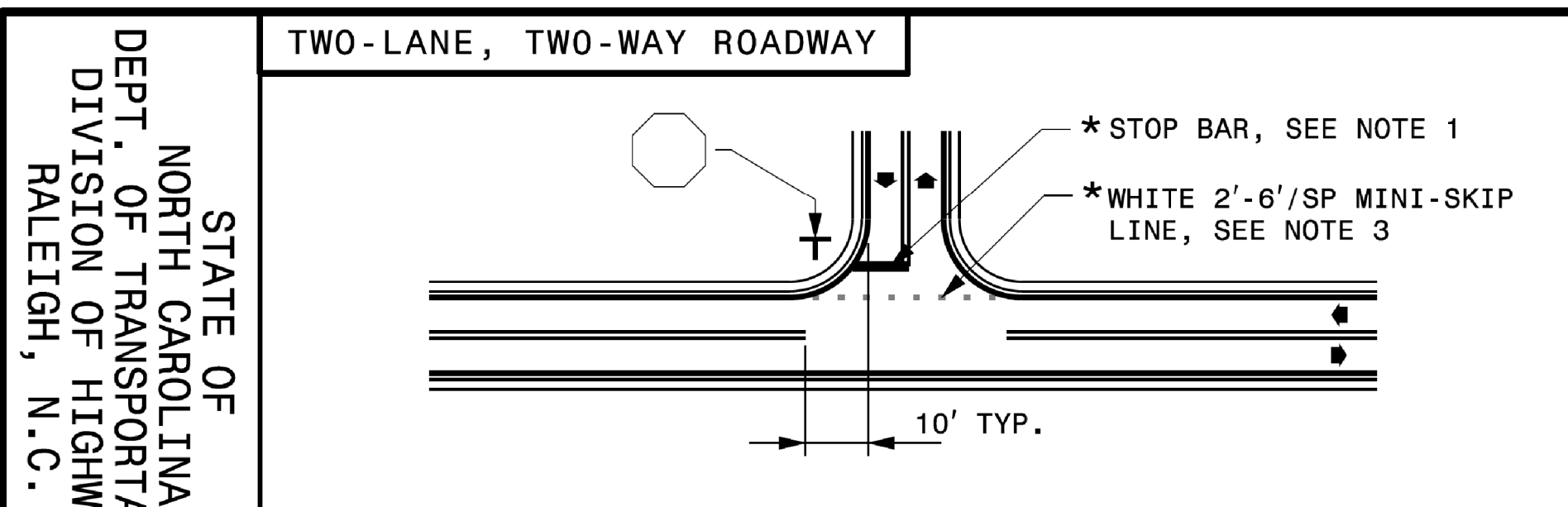
- GENERAL NOTES:**
- 1- PLACEMENT OF STOP BARS AT NON-SIGNALIZED INTERSECTIONS IS OPTIONAL AND USED WHERE IT IS IMPORTANT TO INDICATE THE POINT WHICH VEHICLES ARE REQUIRED TO STOP. PLACE STOP BARS NO LESS THAN 4 FEET AND NO MORE THAN 30 FEET FROM THE NEAREST EDGE OF THE INTERSECTING ROADWAY. USE 10 FEET AS THE TYPICAL SETBACK DISTANCE OR AS DIRECTED BY THE ENGINEER.
 - 2- MINI-SKIP LANE LINE EXTENSIONS SHOULD BE USED AT INTERSECTIONS THAT HAVE REDUCED VISIBILITY CONDITIONS SUCH AS OFFSET, SKEWED, OR CURVED ROADWAYS.
 - 3- MINI-SKIP EDGE LINE EXTENSIONS MAY BE PLACED THROUGH INTERSECTIONS AND MAJOR DRIVEWAYS.
 - 4- REFER TO ROADWAY STANDARD DRAWINGS 1205.01, 1205.02, 1205.05, 1205.08 AND 1205.09 FOR ADDITIONAL PAVEMENT MARKING GUIDANCE.

LEGEND	
	STOP SIGN
	STATIONARY SIGN
	DIRECTION OF TRAFFIC FLOW
	PAVEMENT MARKING SYMBOLS
*	OPTIONAL

USE DOUBLE YELLOW CENTER LINE AND ARROW SYMBOLS IN MEDIAN CROSSOVER WHEN WIDTH OF MEDIAN EXCEEDS 30 FT, OTHERWISE THEY ARE NOT REQUIRED.

SHEET 2 OF 2
1205D04

STATE OF NORTH CAROLINA
 DEPT. OF TRANSPORTATION
 DIVISION OF HIGHWAYS
 RALEIGH, N.C.

8-19
 ENGLISH DETAIL DRAWING FOR
PAVEMENT MARKINGS
 INTERSECTIONS
 SHEET 2 OF 2
1205D04

REVISED PAVEMENT MARKING ROADWAY STANDARD DRAWING

10/14/2022
 X:\VICTOR\A-0009\Traffic\Pavement Markings\A-0009CC\A-0009CC_Sgn_PMP_01A(12050402_08-13-19_Signed).dgn
 User:smelvin

U:\13\1\Standards Group\Standards and Drawings\Drawings\2018 Standard Dwgs\Division 12 Final\12050402_08-13-19.dgn
 User:ststokes

TIP NO. A-0009CC	SHEET NO. PMP-2
APPROVED: <i>Jimmy Terry</i> FD39F3882E94D0	
DATE: 10/18/2022	
SEAL 	
DOCUMENT NOT CONSIDERED FINAL UNLESS ALL SIGNATURES COMPLETED	
TGS ENGINEERS 201 W. MARION ST., STE 200 SHELBY, NC 28150 PH: (704) 476-0003 CORP. LICENSE NO.: C-0275	

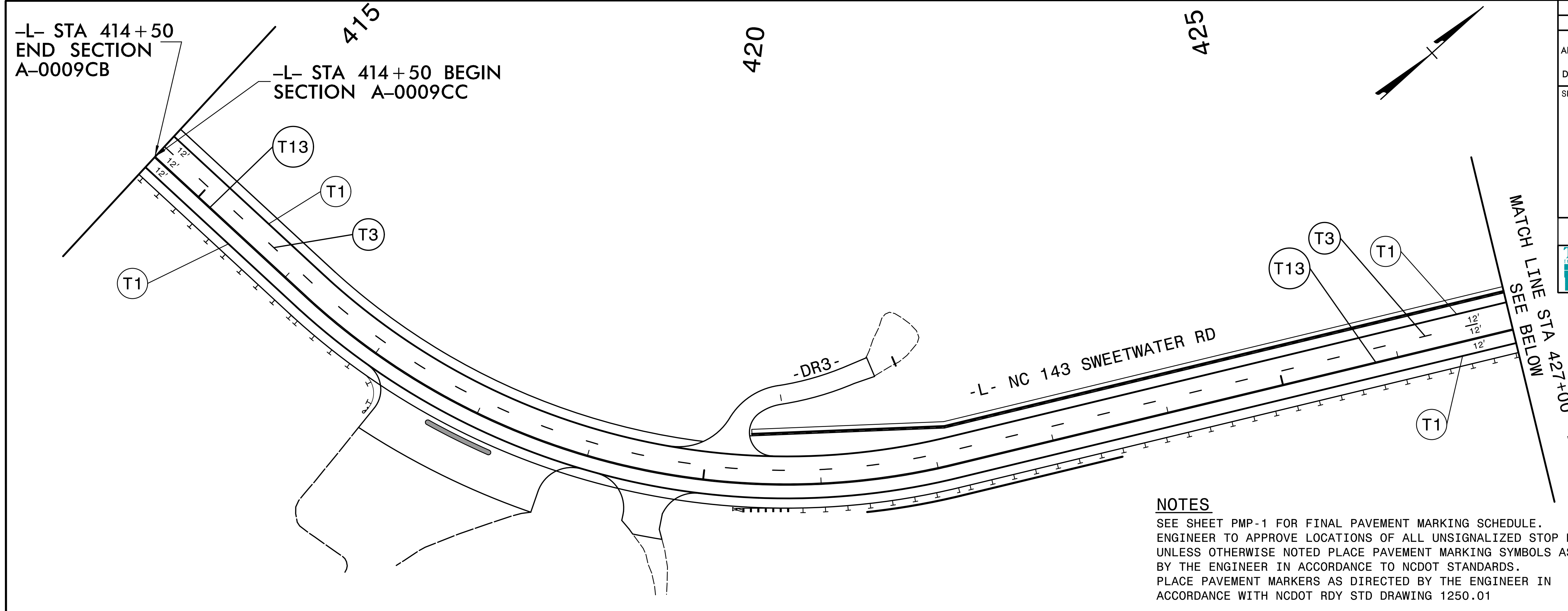

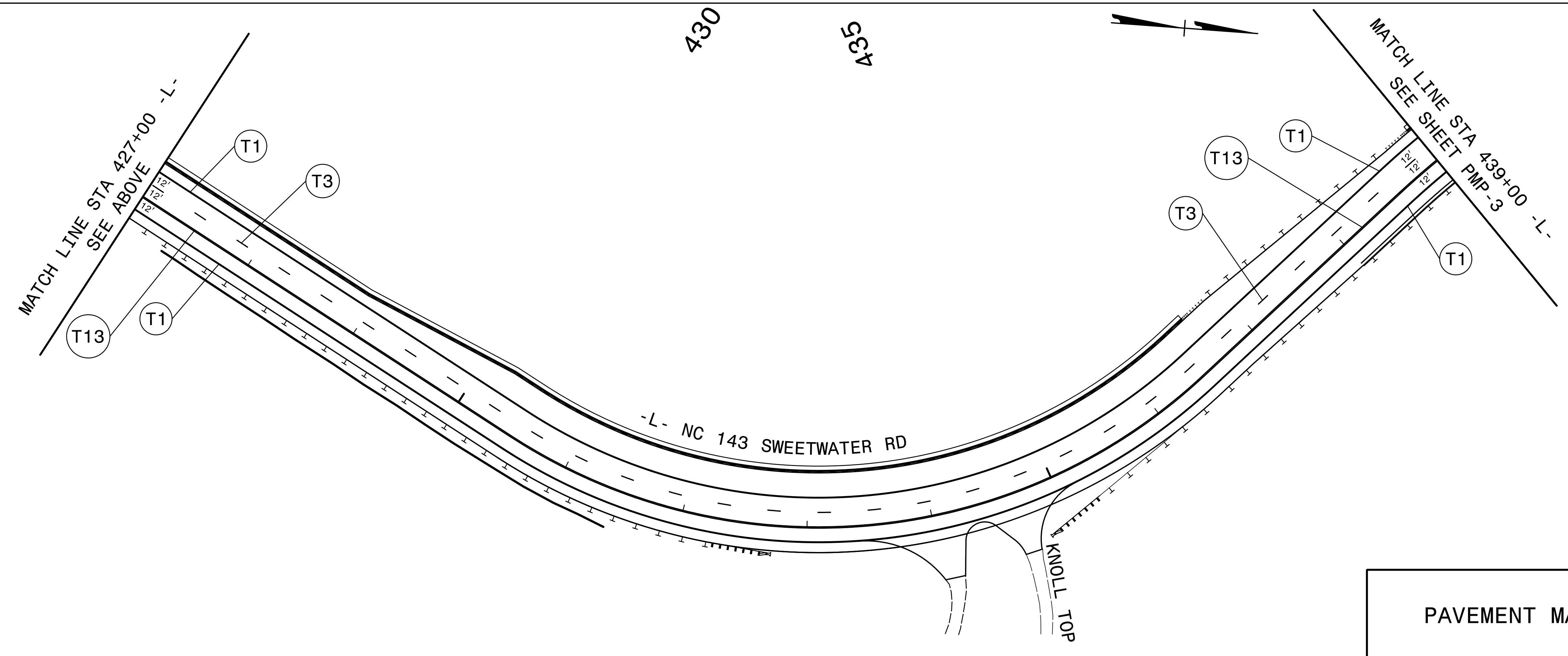

NOTES
 SEE SHEET PMP-1 FOR FINAL PAVEMENT MARKING SCHEDULE.
 ENGINEER TO APPROVE LOCATIONS OF ALL UNSIGNALIZED STOP BARS.
 UNLESS OTHERWISE NOTED PLACE PAVEMENT MARKING SYMBOLS AS DIRECTED
 BY THE ENGINEER IN ACCORDANCE TO NCDOT STANDARDS.
 PLACE PAVEMENT MARKERS AS DIRECTED BY THE ENGINEER IN
 ACCORDANCE WITH NCDOT RDY STD DRAWING 1250.01

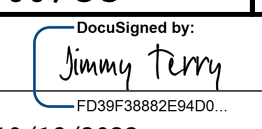

PAVEMENT MARKING DETAIL

I:\10\2022\10\18\2022\A-0009CC\Traffic\ Pavement Markings\A-0009CC\A-0009CC_Sgn_PMP_02.dgn
 User:smelvin

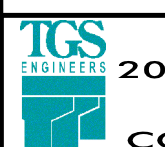
TIP NO. A-0009CC	SHEET NO. PMP-3
APPROVED:  FD99F3882E54D0	
DATE: 10/18/2022	
SEAL	
	
DOCUMENT NOT CONSIDERED FINAL UNLESS ALL SIGNATURES COMPLETED	
 TGS ENGINEERS 201 W. MARION ST., STE 200 SHELBY, NC 28150 PH: (704) 476-0003 CORP. LICENSE NO.: C-0275	

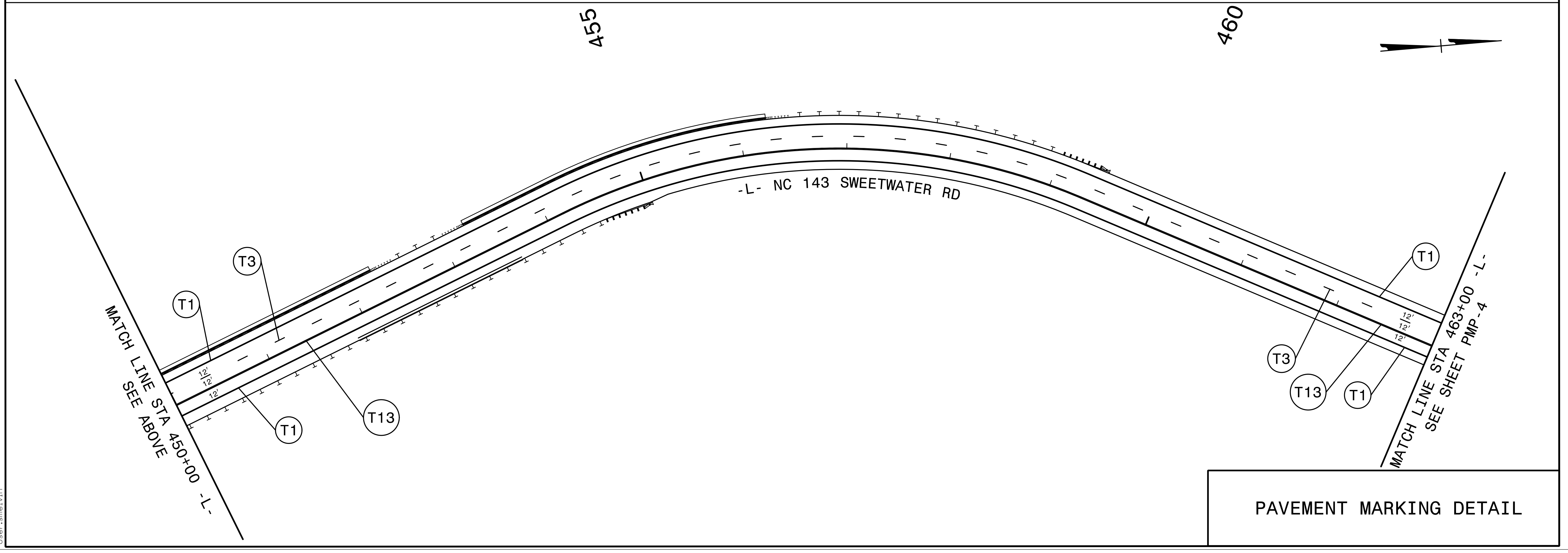
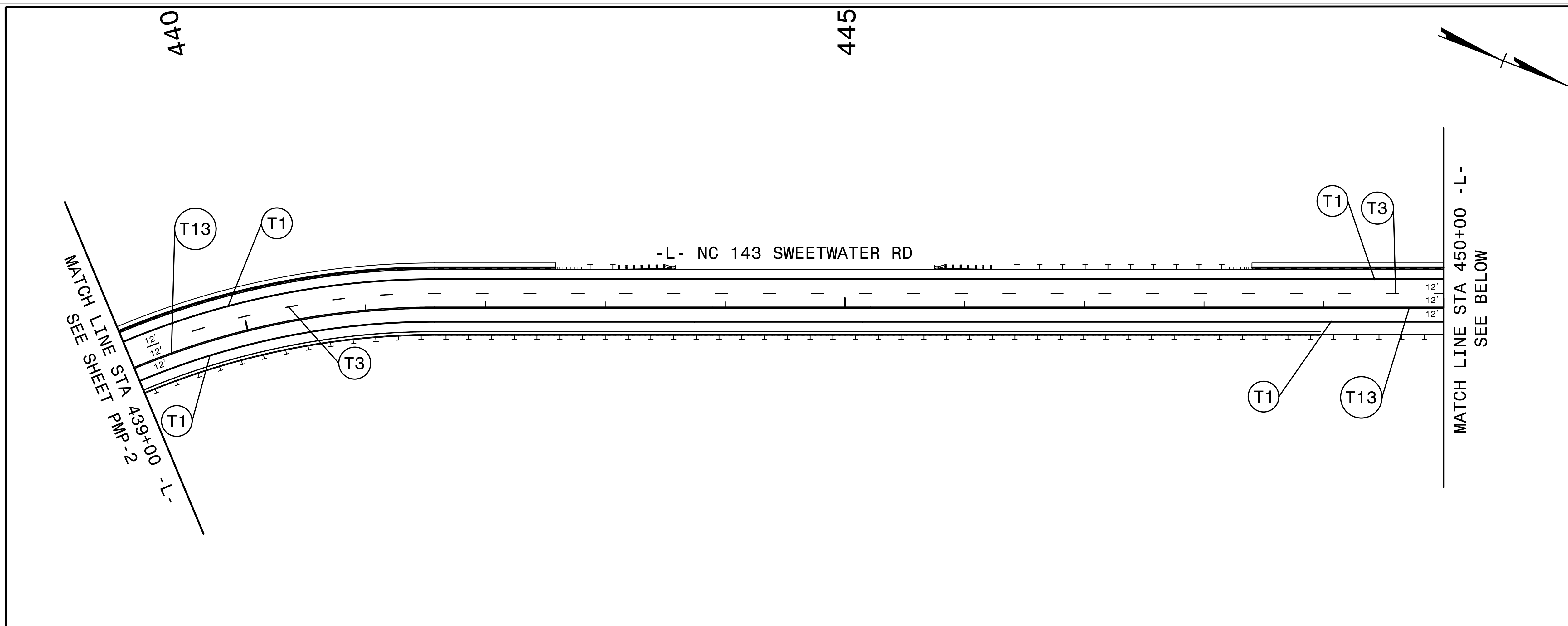

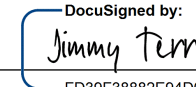
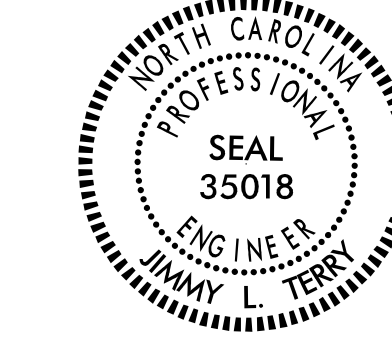

PAVEMENT MARKING DETAIL

I:\10\14\2022\A-0009\Traffic\Pavement Markings\A-0009CC\A-0009CC_Sgn_PMP_03.dgn
User: smelvin

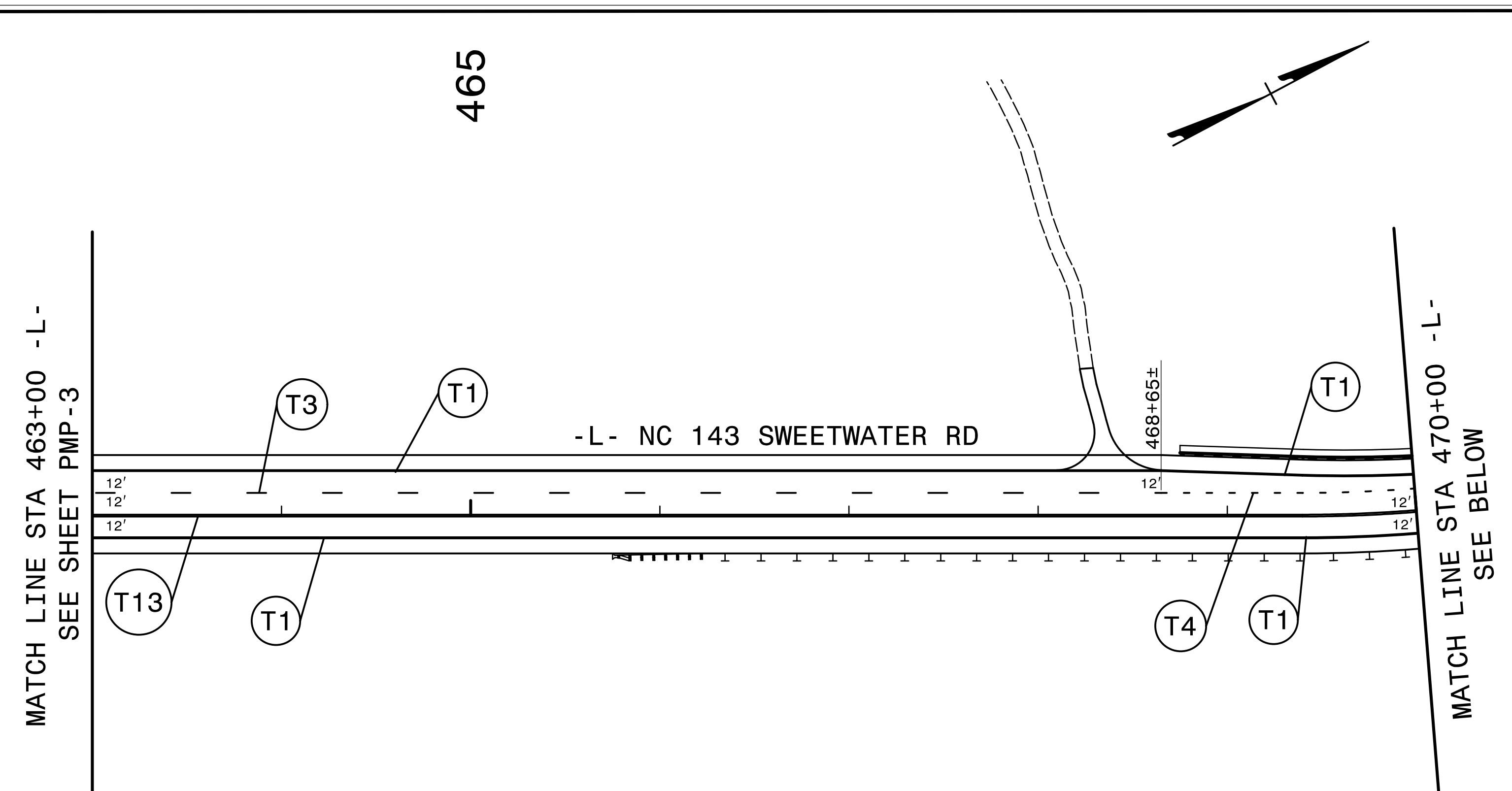
TIP NO. A-0009CC	SHEET NO. PMP-4
APPROVED:  10/18/2022	
DATE: 10/18/2022	
SEAL 	
DOCUMENT NOT CONSIDERED FINAL UNLESS ALL SIGNATURES COMPLETED	
TGS ENGINEERS 201 W. MARION ST. STE 200 SHELBY, NC 28150 PH: (704) 476-0003 CORP. LICENSE NO.: C-0275	



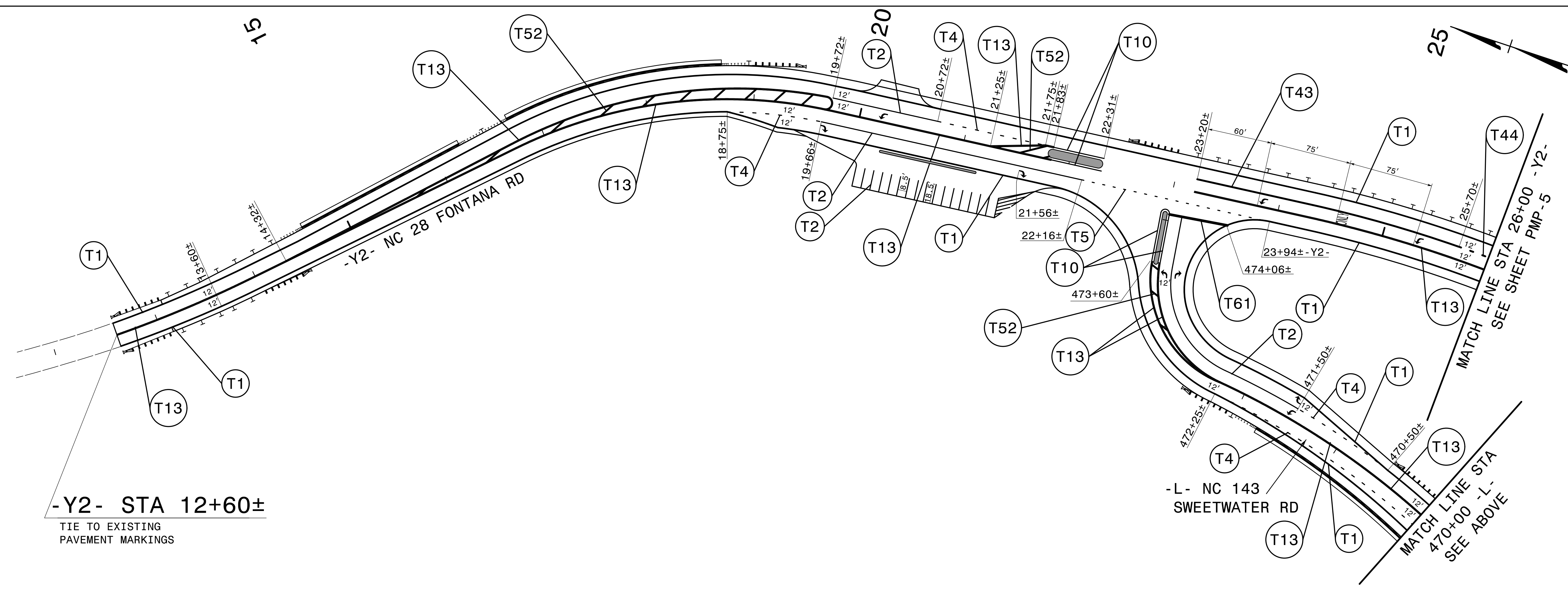

PAVEMENT MARKING SYMBOLS

	T70
	T71
ONLY	T100

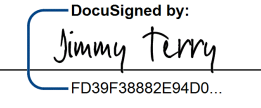

PAVEMENT MARKING DETAIL

I:\04\2022\X:\NC\001\A-0009\Traffic\ Pavement Markings\A-0009CC\A-0009CC_Sgn_PMP_04.dgn
 User:smelvin

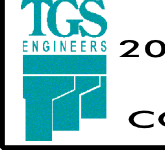
TIP NO. A-0009CC	SHEET NO. PMP-5
APPROVED:  FD38F3882E4D0E	
DATE: 10/18/2022	
SEAL	
	
DOCUMENT NOT CONSIDERED FINAL UNLESS ALL SIGNATURES COMPLETED	
 TGS ENGINEERS 201 W. MARION ST., STE 200 SHELBY, NC 28150 PH: (704) 476-0003 CORP. LICENSE NO.: C-0275	

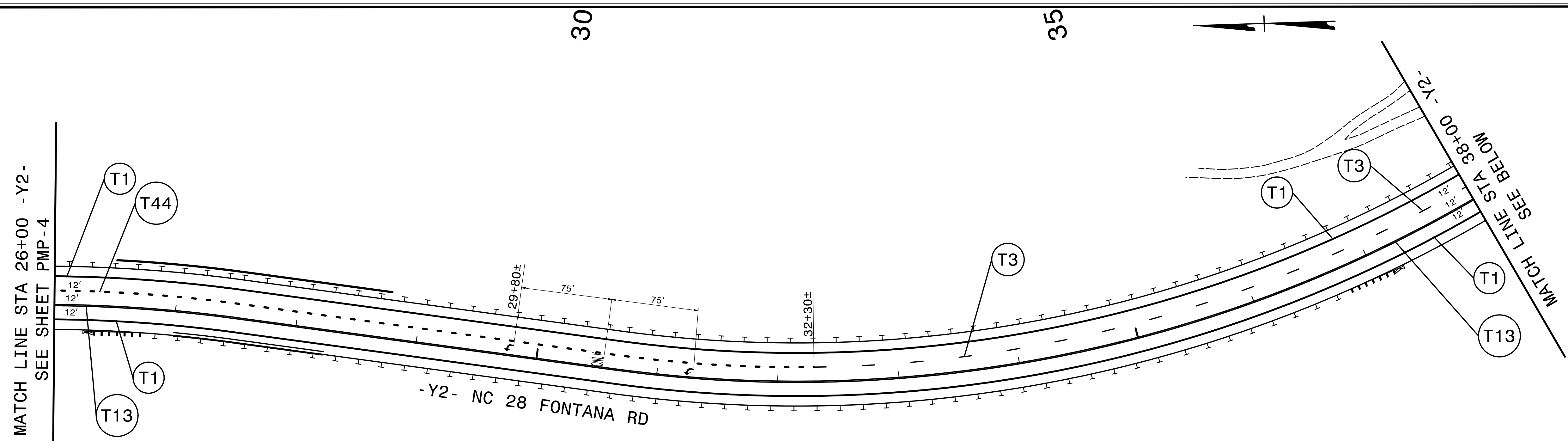

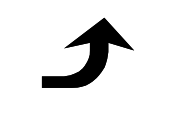

PAVEMENT MARKING SYMBOLS

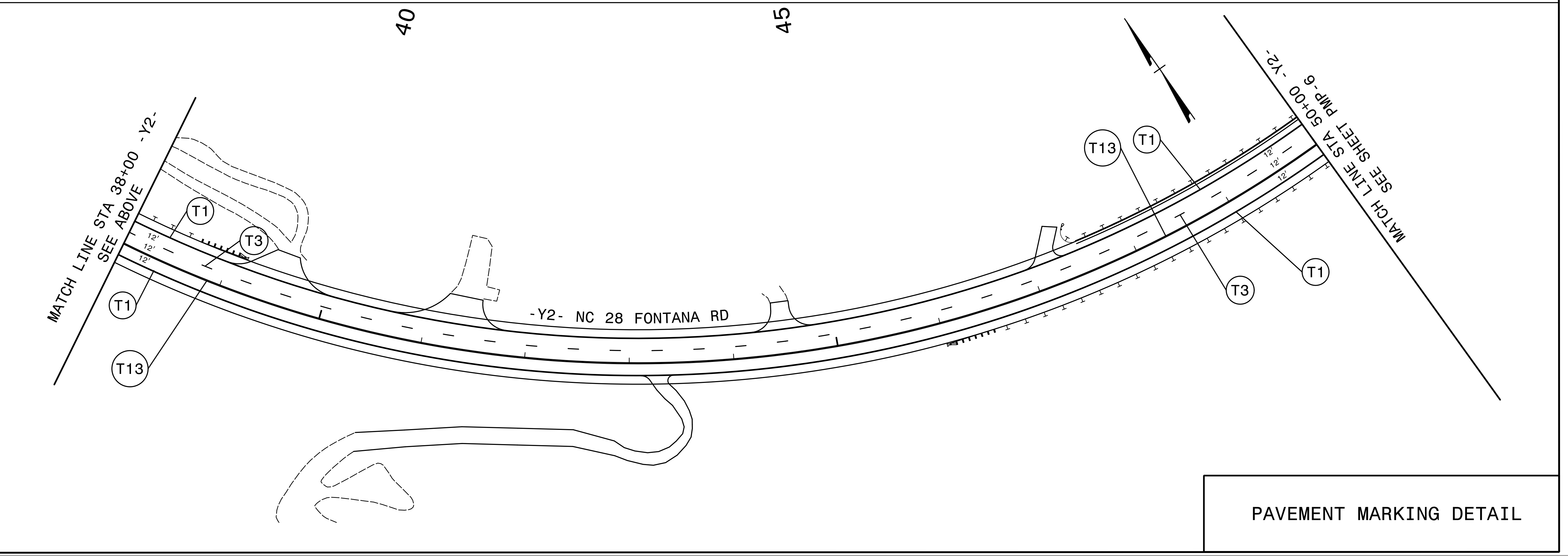
	T70
ONLY	T100



PAVEMENT MARKING DETAIL

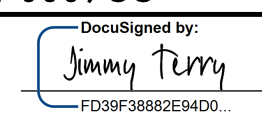

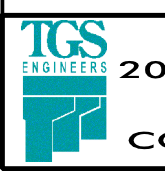
10/14/2022
 X:\NC\001\A-0009\Traffic\Pavement Markings\A-0009CC\A-0009CC_Sgn_PMP_05.dgn
 User:smelvin

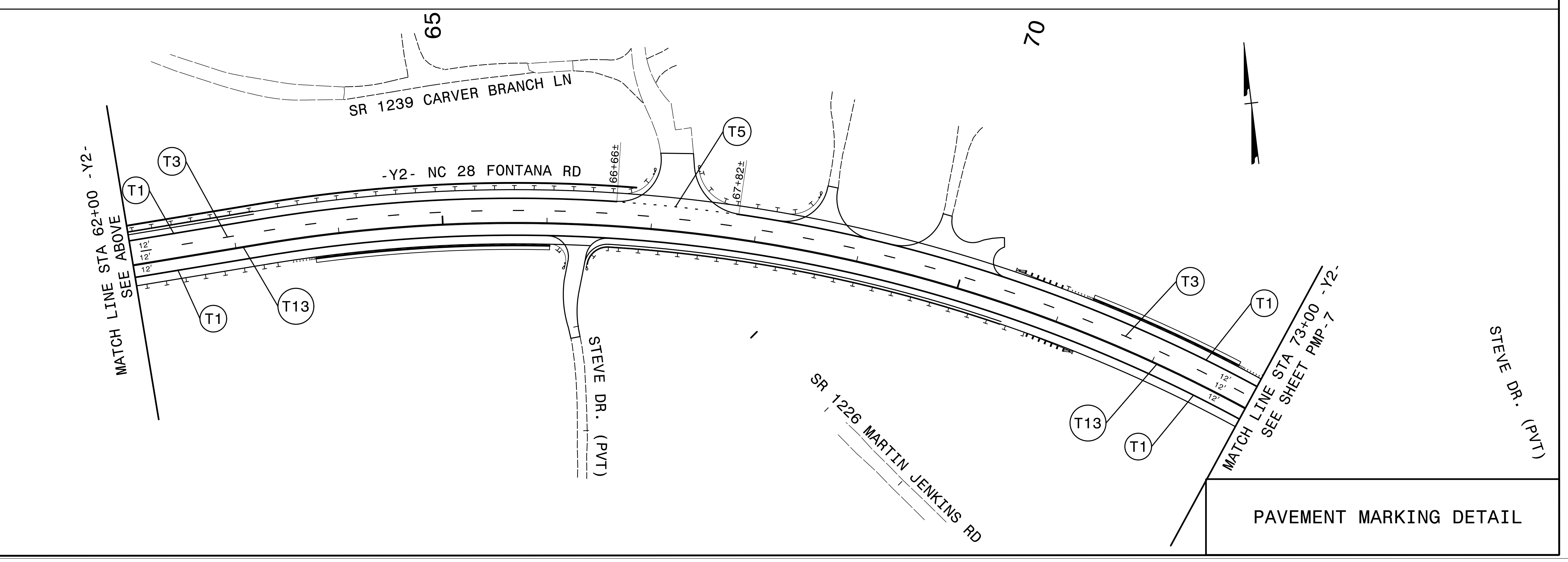
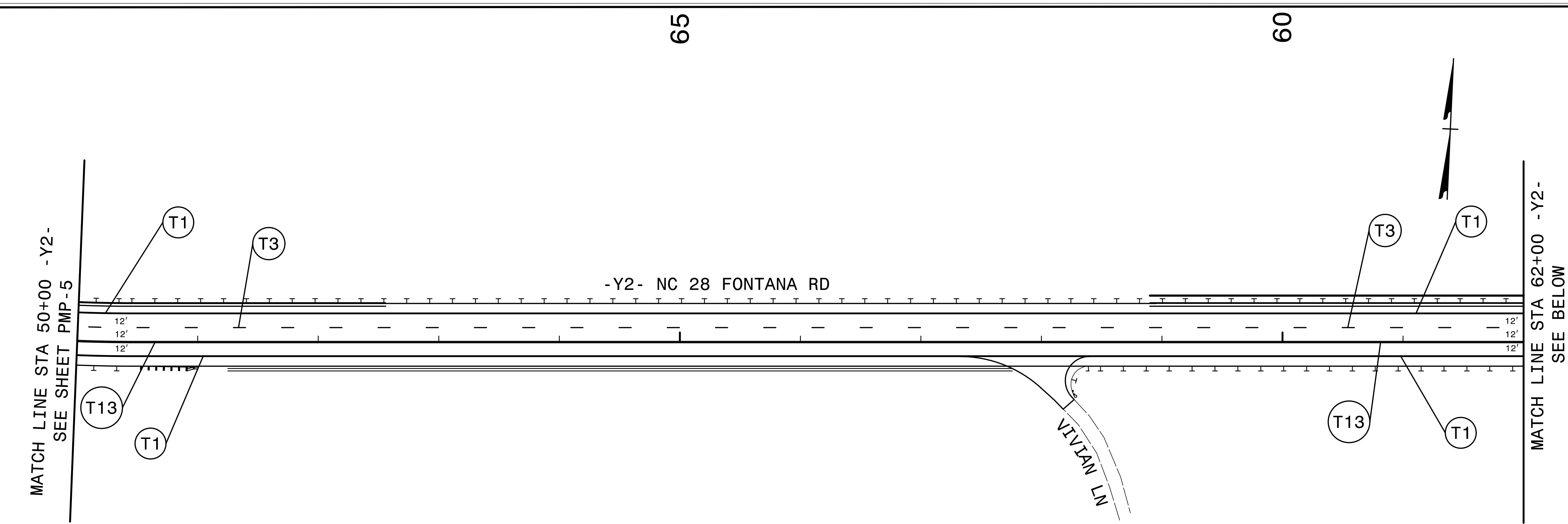
TIP NO. A-0009CC	SHEET NO. PMP-6
APPROVED: 	
DATE: 10/18/2022	
SEAL	
	
DOCUMENT NOT CONSIDERED FINAL UNLESS ALL SIGNATURES COMPLETED	
 TGS ENGINEERS 201 W. MARION ST., STE 200 SHELBY, NC 28150 PH: (704) 476-0003 CORP. LICENSE NO.: C-0275	

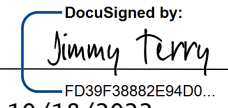

PAVEMENT MARKING DETAIL

I:\10\14\2022\X:\NC\001\A-0009\Traffic\Pavement_Markings\A-0009CC\A-0009CC_Sgn_PMP_06.dgn
User:smelvin

TIP NO. A-0009CC	SHEET NO. PMP-7
APPROVED:  DATE: 10/18/2022	
SEAL 	
DOCUMENT NOT CONSIDERED FINAL UNLESS ALL SIGNATURES COMPLETED	
TGS ENGINEERS 201 W. MARION ST., STE 200 SHELBY, NC 28150 PH (704) 476-0003 CORP. LICENSE NO.: C-0275	

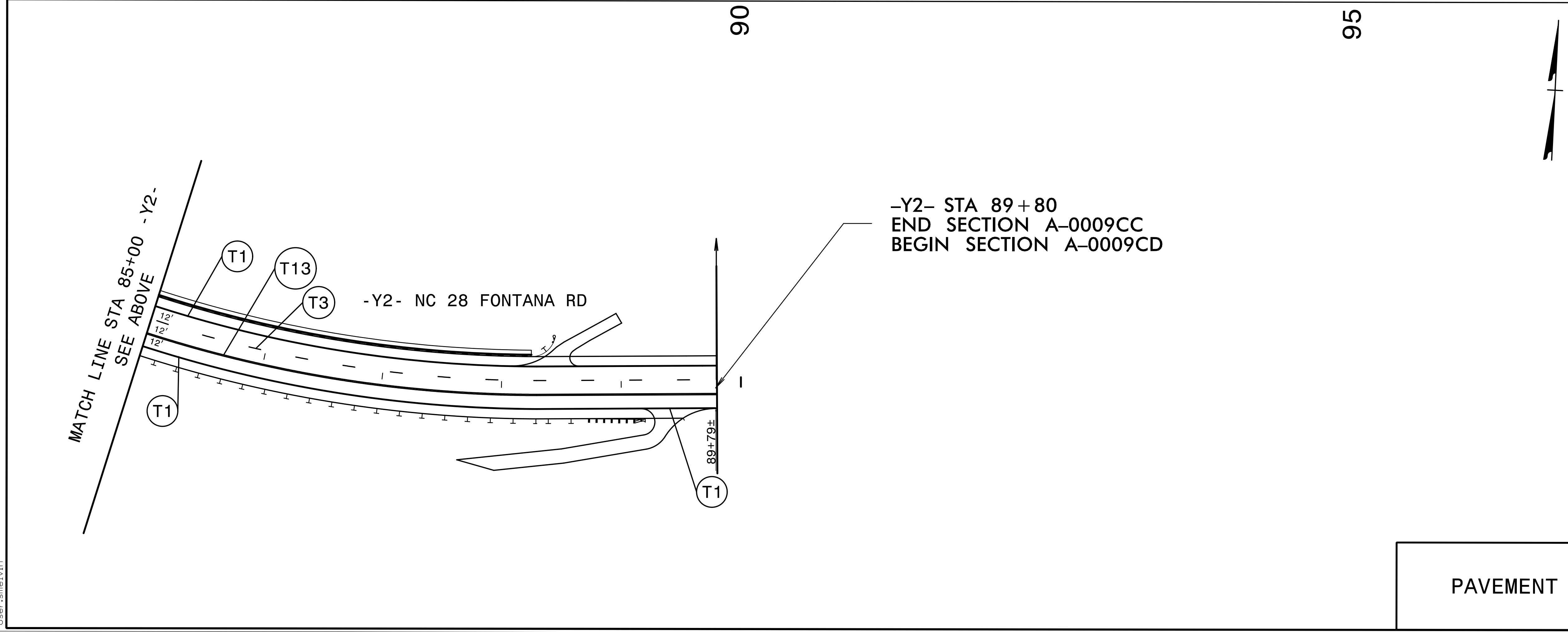
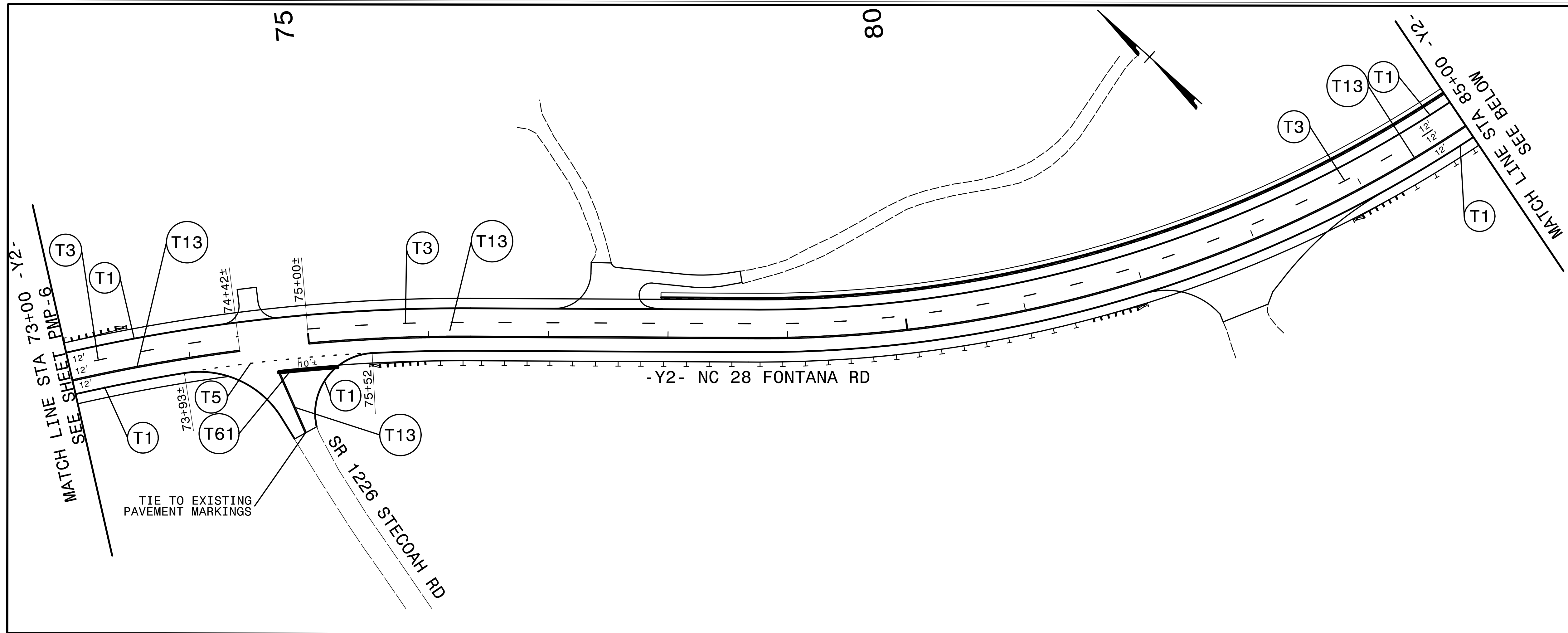

PAVEMENT MARKING DETAIL

10/17/2022
X:\NC009\A-0009\Traffic\Pavement_Markings\VA-0009CC-A-0009CC_Sgn_PMP_07.dgn
User:smelvin