

UTILITIES BY OTHERS

ALL PROPOSED UTILITY WORK SHOWN ON THIS SHEET WILL BE DONE BY OTHERS. NO PAYMENT WILL BE MADE TO THE CONTRACTOR FOR PROPOSED UTILITY WORK SHOWN ON THIS SHEET.

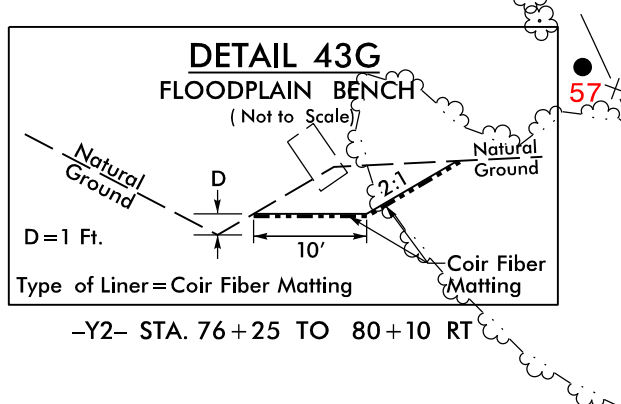
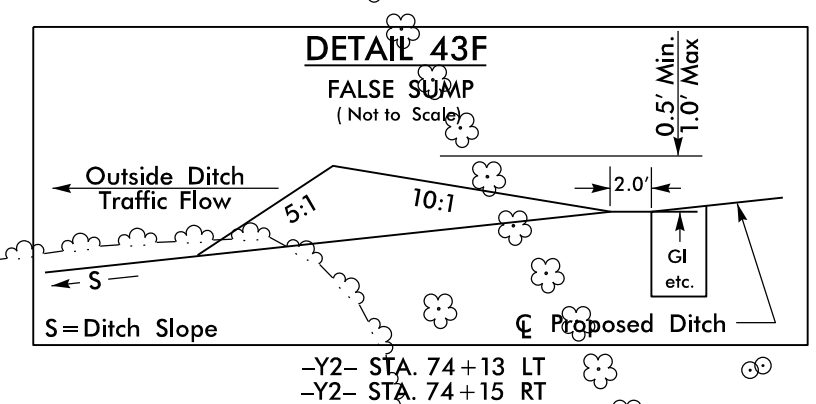
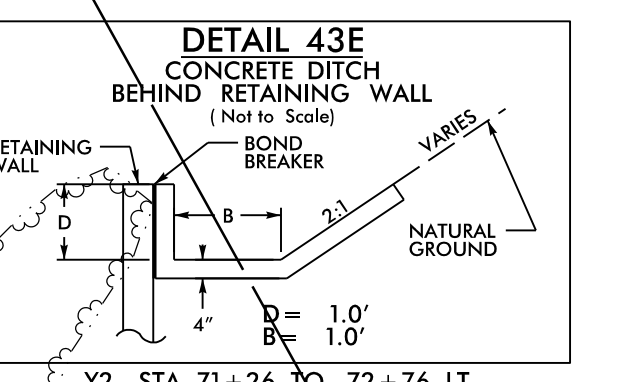
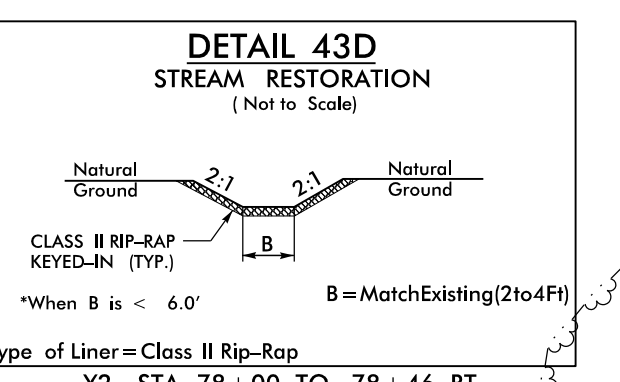
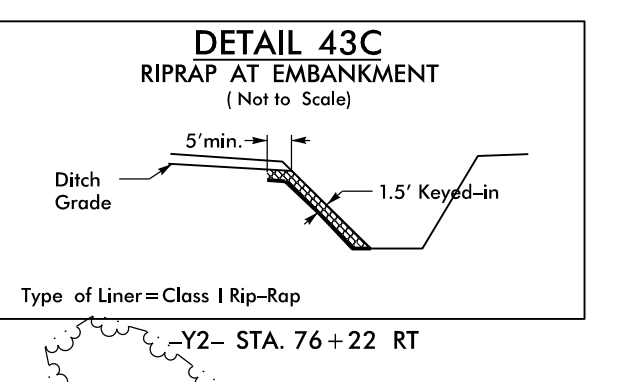
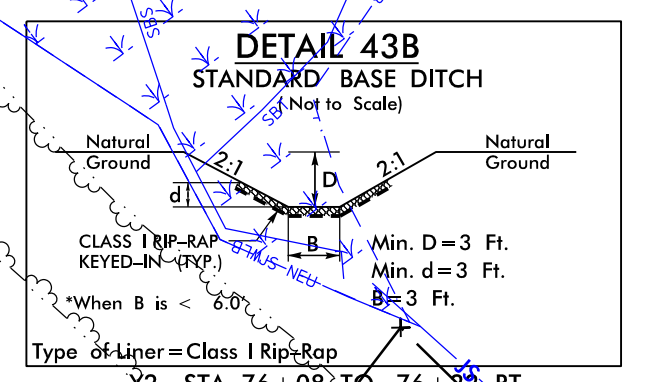
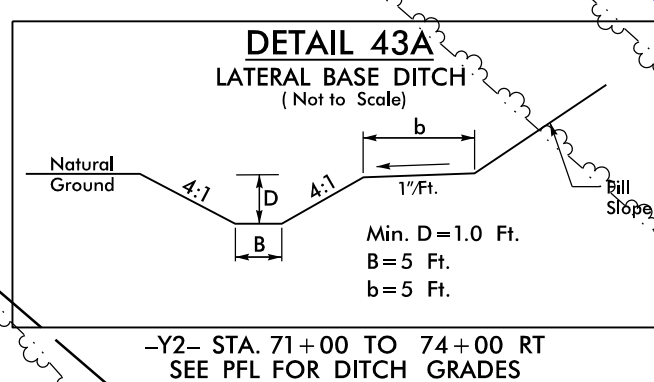
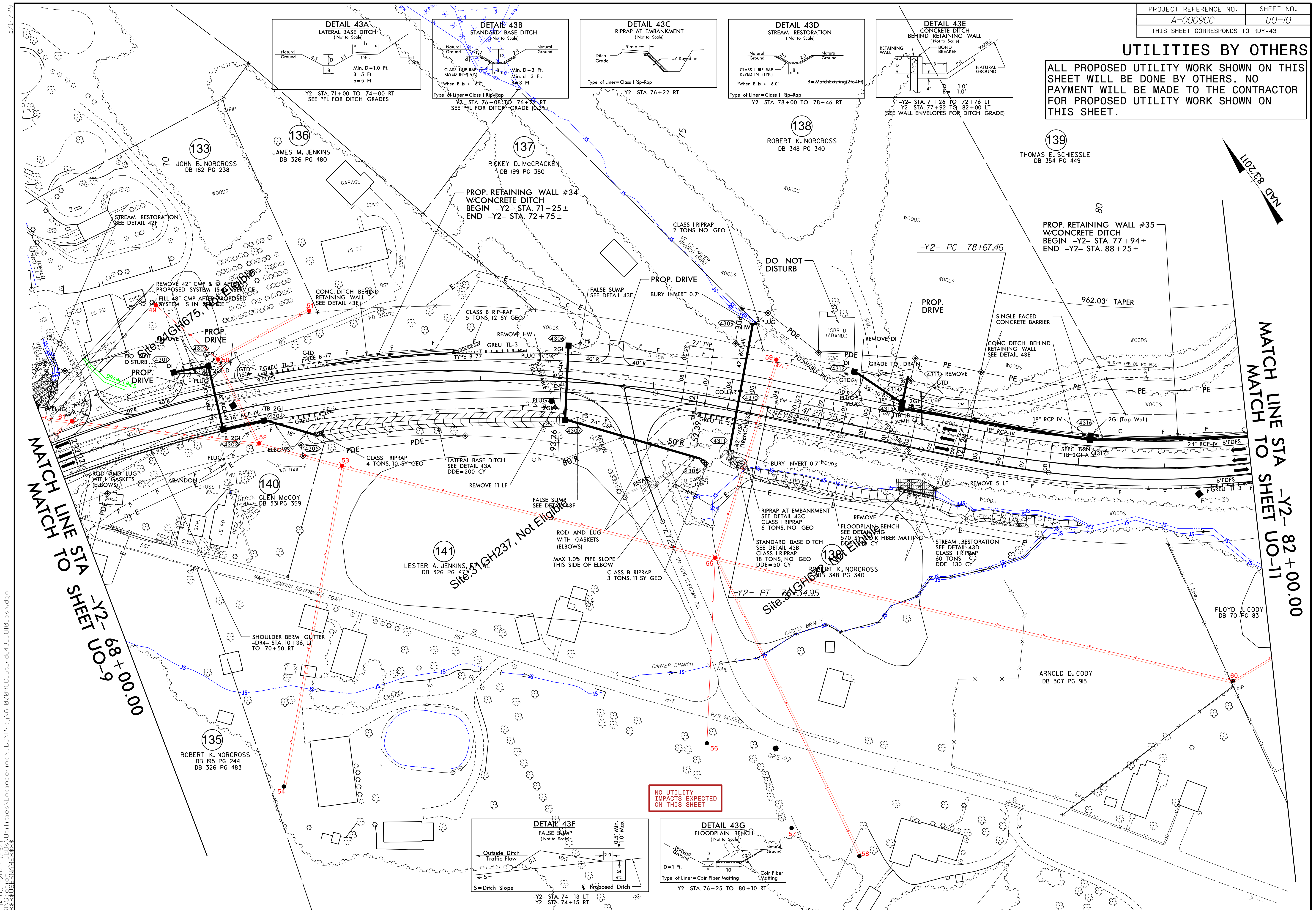

NO UTILITY IMPACTS EXPECTED ON THIS SHEET

5/14/99
14-OCT-2022 09:27 Utilities\Engineering\UBO\Proj\A-0009CC-ut_rdy\43-U010_psh.dgn
10/23/2022 10:53:33 AM

MATCH LINE STA -Y2- 82+00.00
MATCH LINE TO SHEET UO-11

MATCH LINE TO SHEET -Y2- UO-9
MATCH LINE TO SHEET -Y2- 68+00.00