

5/14/2022

14-OCT-2022 08:21  
C:\Users\jstern\Documents\Engineering\UBD\Proj\A-0009CC.ctb.rdy40\_U007\_psh.dgn

PROJECT REFERENCE NO.	SHEET NO.
A-0009CC	U0-7
THIS SHEET CORRESPONDS TO RDY-40	

### UTILITIES BY OTHERS

ALL PROPOSED UTILITY WORK SHOWN ON THIS SHEET WILL BE DONE BY OTHERS. NO PAYMENT WILL BE MADE TO THE CONTRACTOR FOR PROPOSED UTILITY WORK SHOWN ON THIS SHEET.

**-Y2- CURVE DATA**

PI Sta 25+91.41	PI Sta 44+39.36
$\Delta = 15^{\circ}17'06.5"$ (RT)	$\Delta = 102^{\circ}05'50.9"$ (LT)
$D = 4^{\circ}46'28.7"$	$D = 5^{\circ}09'42.4"$
$L = 320.13'$	$L = 1,977.95'$
$T = 161.02'$	$T = 1,373.12'$
$R = 1,200.00'$	$R = 1,110.00'$
$SE = 0.08$	$SE = 0.08$
$DS = 60$ MPH	$DS = 55$ MPH

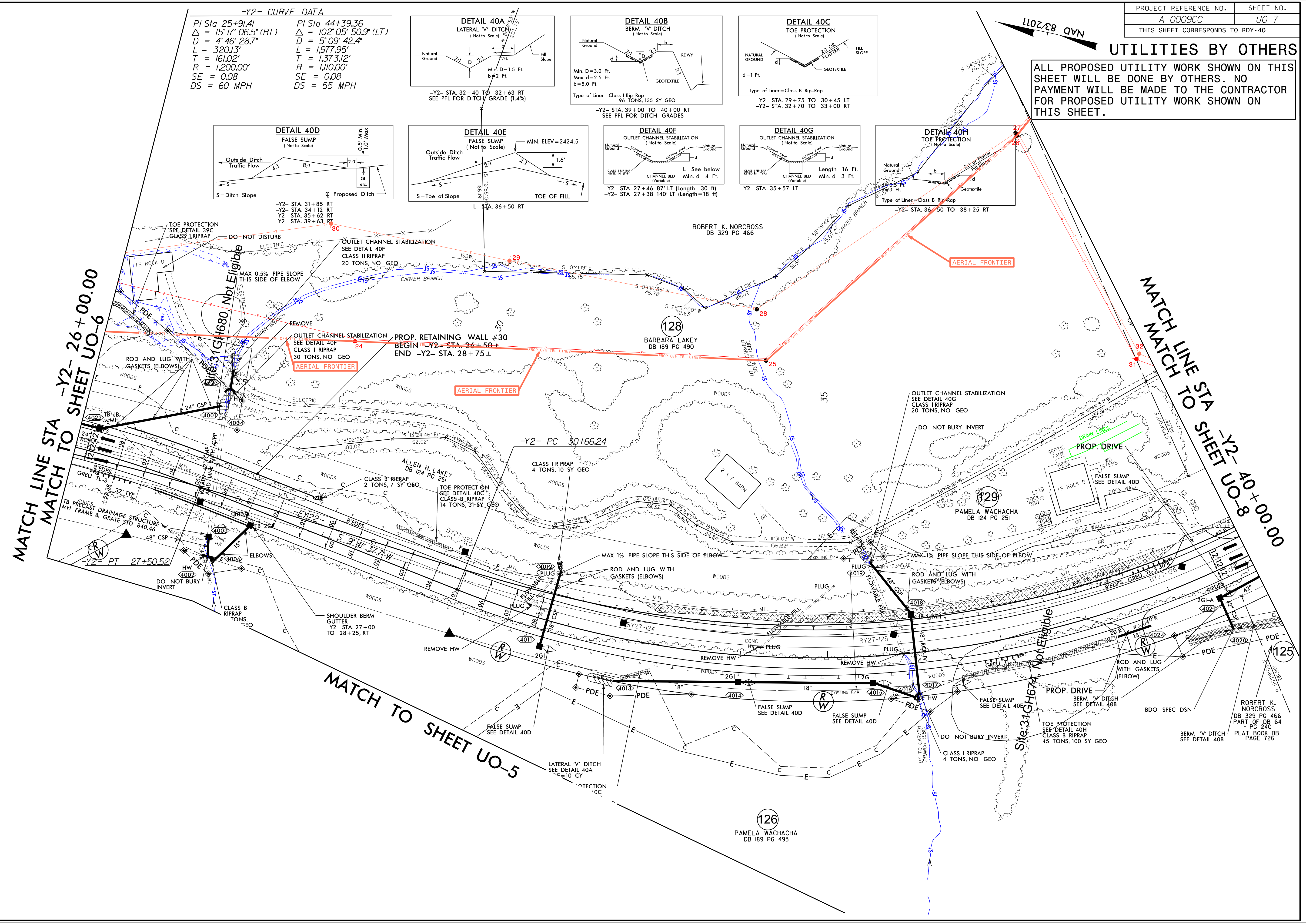
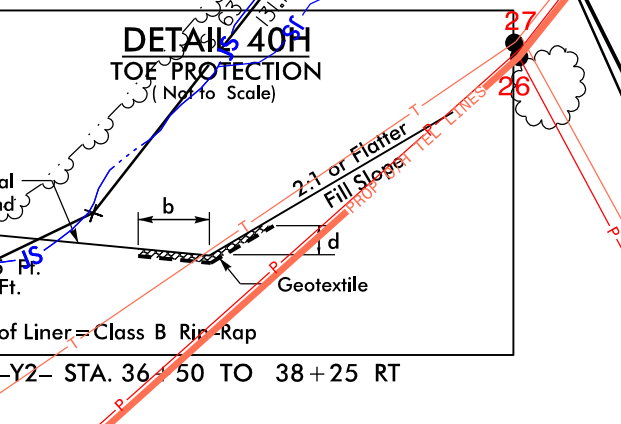
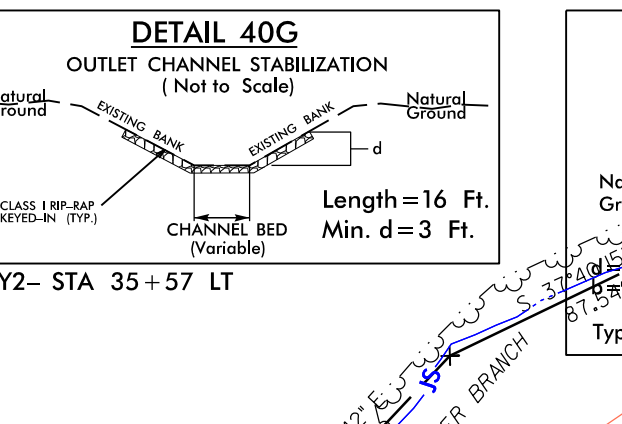
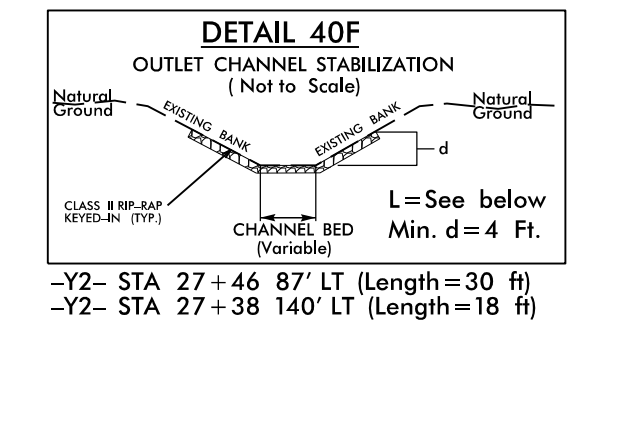
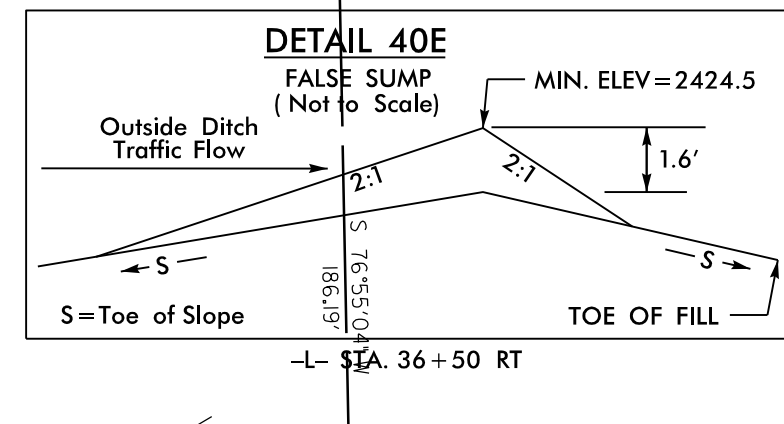
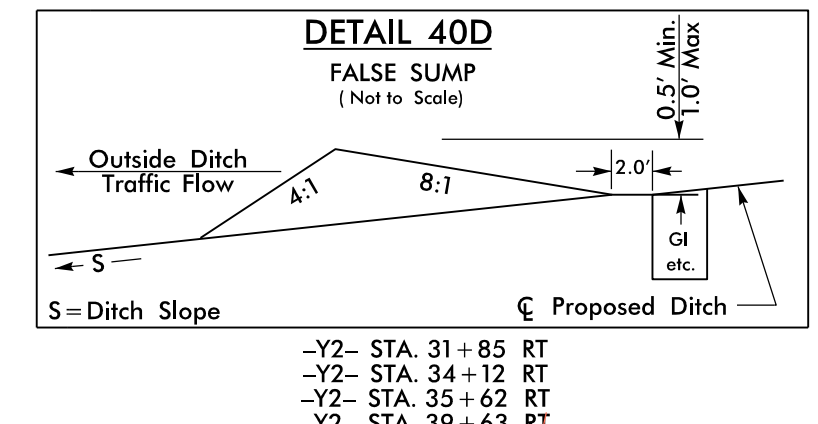
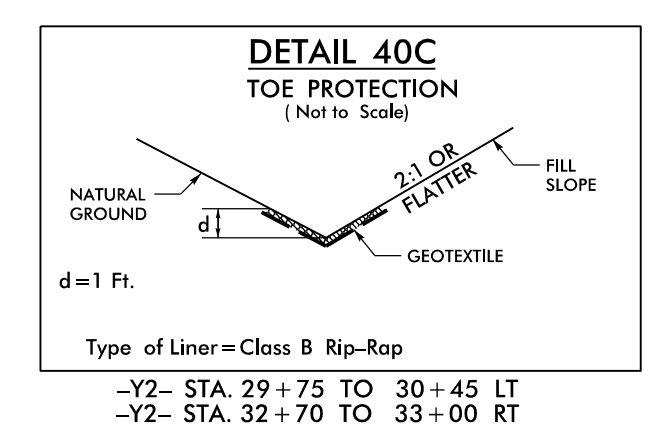
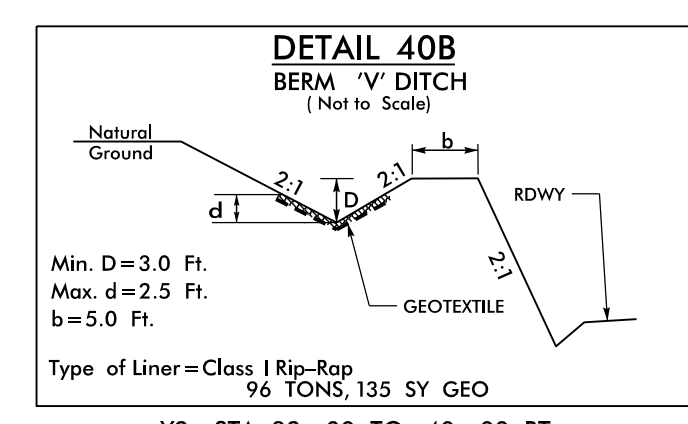
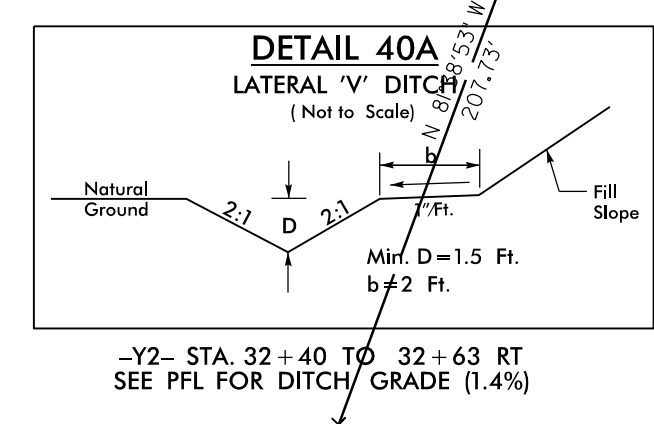

MATCH LINE STA -Y2- 26+00.00  
MATCH TO SHEET UO-6

MATCH LINE STA -Y2- 40+00.00  
MATCH TO SHEET UO-8

MATCH TO SHEET UO-5

Site 31GH674 Not Eligible

ROBERT K. NORCROSS  
DB 329 PG 466  
PART OF DB 64  
- PG 240  
PLAT BOOK DB  
- PAGE 726