

### UTILITIES BY OTHERS

ALL PROPOSED UTILITY WORK SHOWN ON THIS SHEET WILL BE DONE BY OTHERS. NO PAYMENT WILL BE MADE TO THE CONTRACTOR FOR PROPOSED UTILITY WORK SHOWN ON THIS SHEET.

-Y2- CURVE DATA			-L- CURVE DATA		
PI Sta 11+99.45	PI Sta 18+27.84	PI Sta 25+91.41	PI Sta 470+84.26	PI Sta 473+03.33	
$\Delta = 19^{\circ} 44' 48.4" (LT)$	$\Delta = 38^{\circ} 45' 19.5" (RT)$	$\Delta = 15^{\circ} 17' 06.5" (RT)$	$\Delta = 2^{\circ} 31' 55.6" (LT)$	$\Delta = 75^{\circ} 53' 24.9" (RT)$	
D = 5' 00" 00.0"	D = 12' 52" 31.6"	D = 4' 46" 28.7"	D = 7' 32" 20.1"	D = 57' 17" 44.8"	
L = 394.94'	L = 301.00'	L = 320.13'	L = 285.61'	L = 132.45'	
T = 199.45'	T = 156.51'	T = 161.02'	T = 144.51'	T = 77.97'	
R = 1,145.92'	R = 445.00'	R = 1,200.00'	R = 760.00'	R = 100.00'	
SE = 0.08	SE = 0.08	SE = 0.08	SE = 0.04	SE = 0.03	
DS = 55 MPH	DS = 40 MPH	DS = 60 MPH	DS = 45 MPH	DS = 20 MPH	

① -Y2- PC 24+30.38

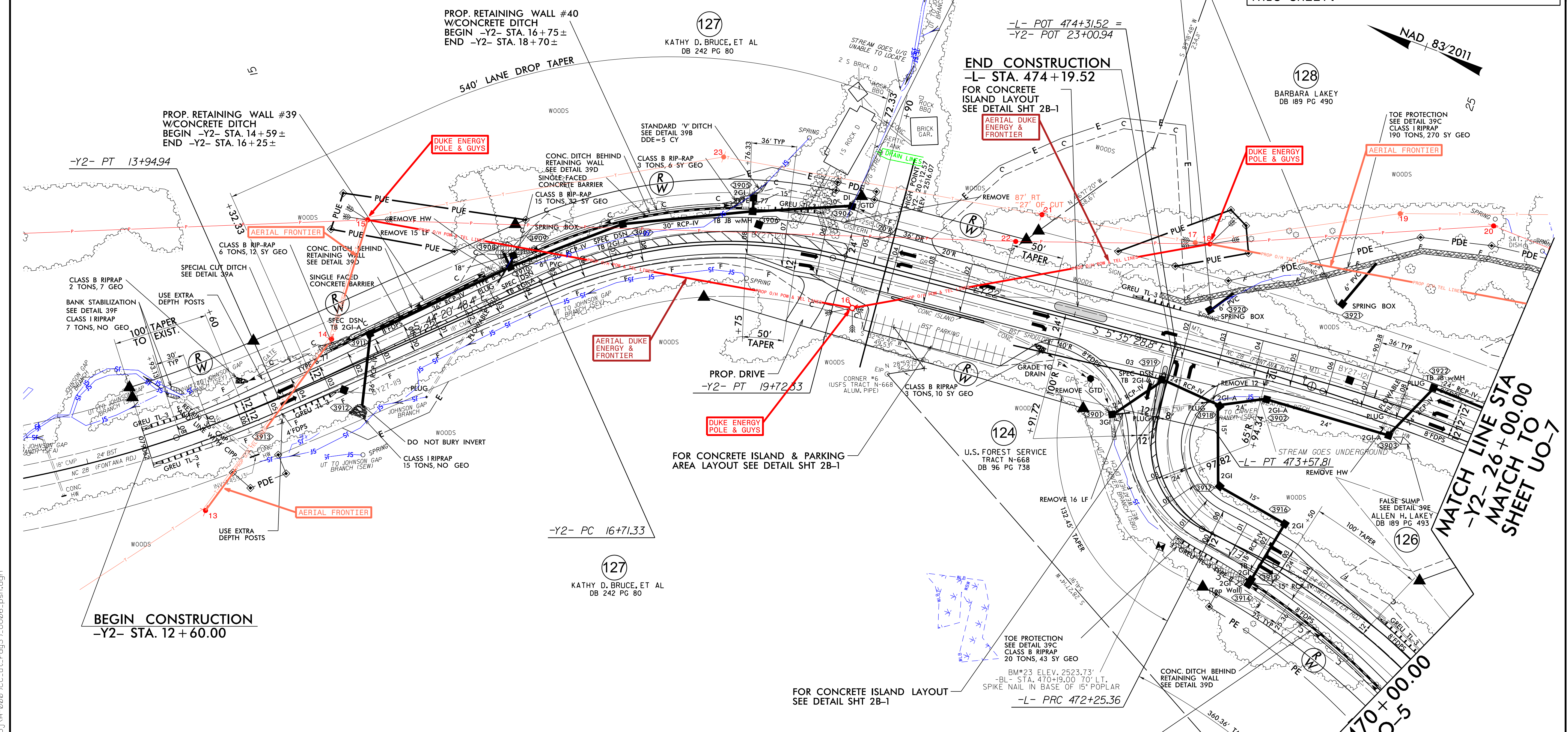

**BEGIN CONSTRUCTION**  
-Y2- STA. 12 + 60.00

**END CONSTRUCTION**  
-L- STA. 474 + 19.52  
FOR CONCRETE ISLAND LAYOUT  
SEE DETAIL SHT 2B-1

FOR CONCRETE ISLAND & PARKING AREA LAYOUT  
SEE DETAIL SHT 2B-1

FOR CONCRETE ISLAND LAYOUT  
SEE DETAIL SHT 2B-1

**PROP. RETAINING WALL #25**  
W/CONCRETE DITCH  
BEGIN -L- STA. 468 + 75.00  
END -L- STA. 471 + 75.00

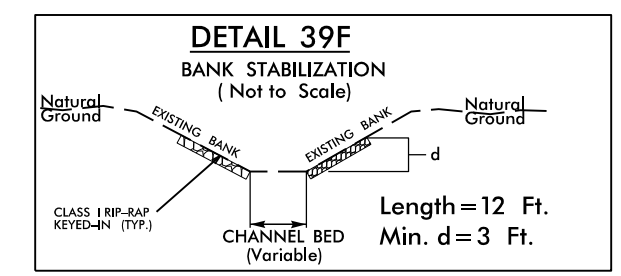
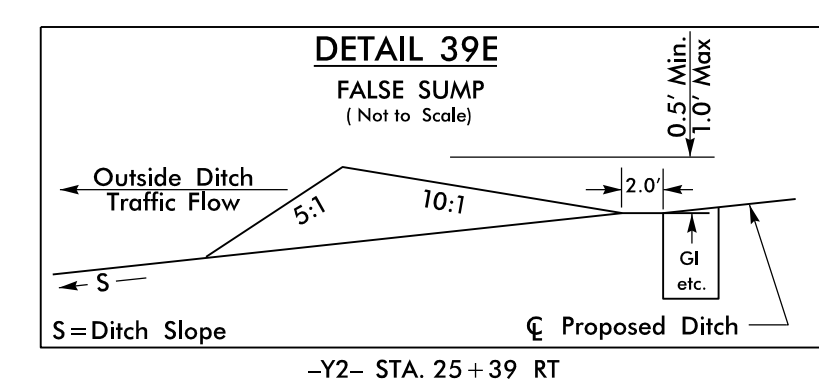
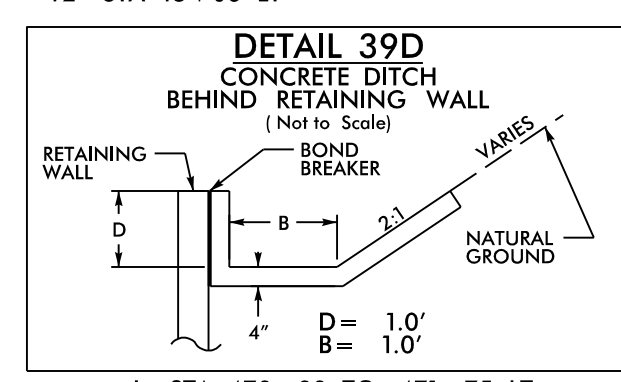
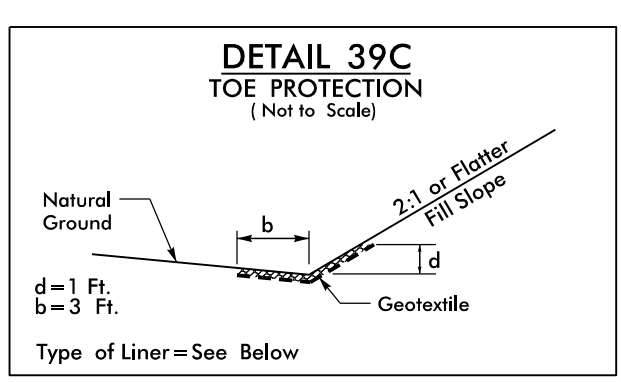
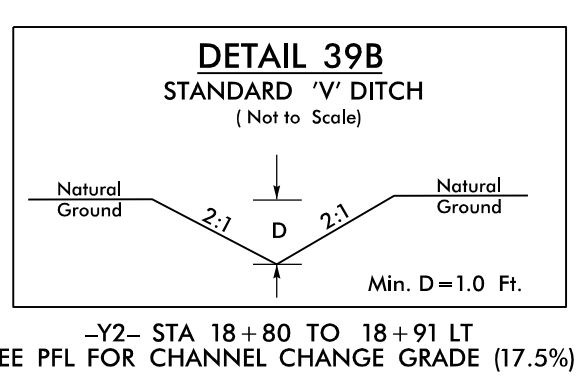
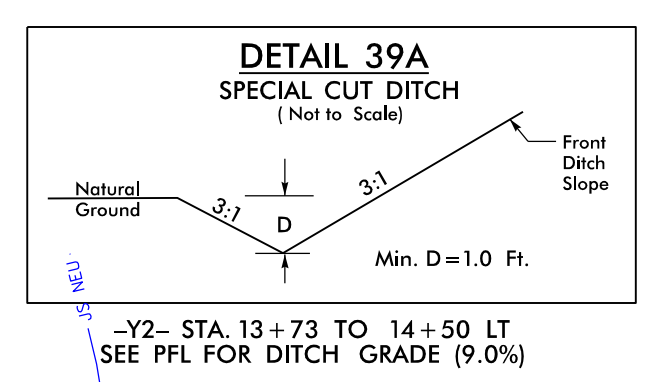

**MATCH LINE STA -Y2- 26 + 00.00**  
**MATCH TO SHEET UO-7**

**MATCH LINE STA -L- 470 + 00.00**  
**MATCH TO SHEET UO-5**

5/14/09  
14-OCT-2022 08:16  
C:\Users\jacob\OneDrive\Engineering\UBO\Proj\A-0009CC-ut.-rdy39\_u006\_psh.dgn