

PROJECT REFERENCE NO.	SHEET NO.
A-0009CC	UO-4
THIS SHEET CORRESPONDS TO RDY-37	

UTILITIES BY OTHERS

ALL PROPOSED UTILITY WORK SHOWN ON THIS SHEET WILL BE DONE BY OTHERS. NO PAYMENT WILL BE MADE TO THE CONTRACTOR FOR PROPOSED UTILITY WORK SHOWN ON THIS SHEET.



-L- CURVE DATA
 PI Sta 456+91.51
 $\Delta = 49^{\circ}15'00.2" (RT)$
 $D = 9^{\circ}32'57.5"$
 $L = 515.75'$
 $R = 275.02'$
 $SE = 0.08$
 $DS = 45 \text{ MPH}$

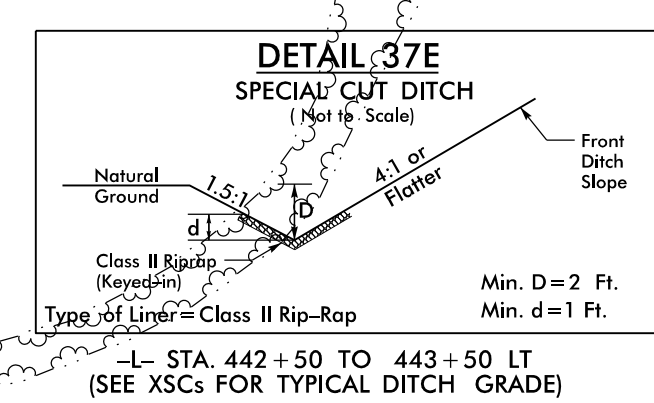
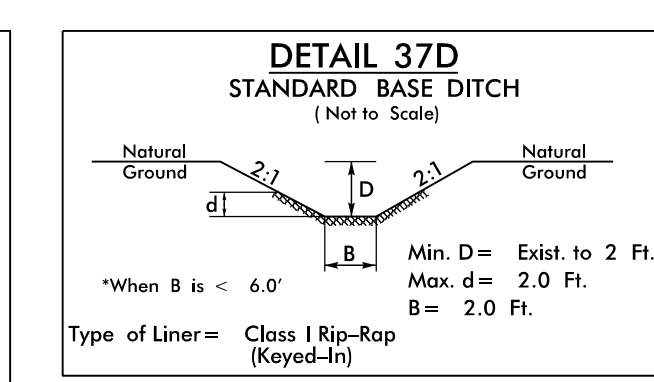
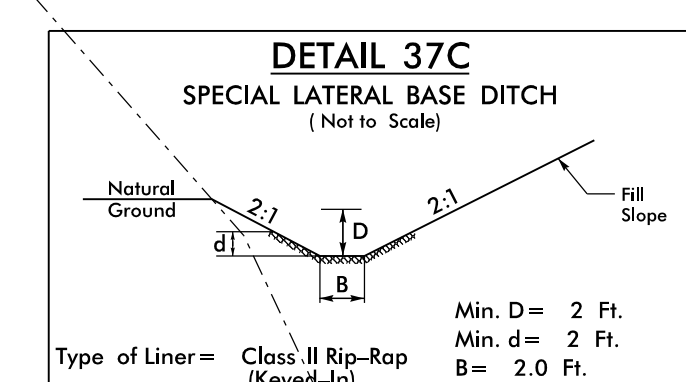
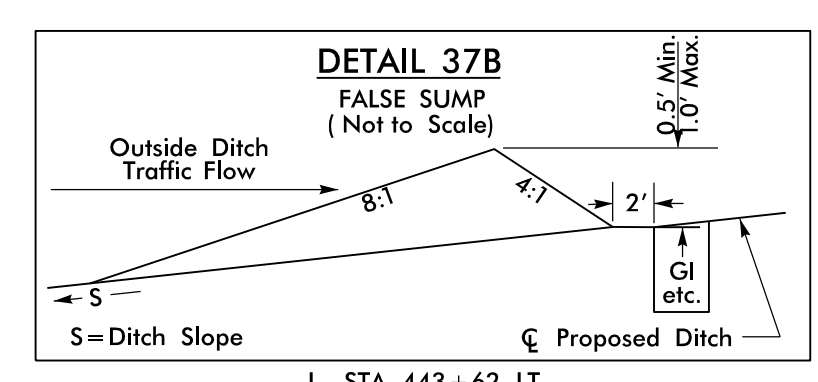
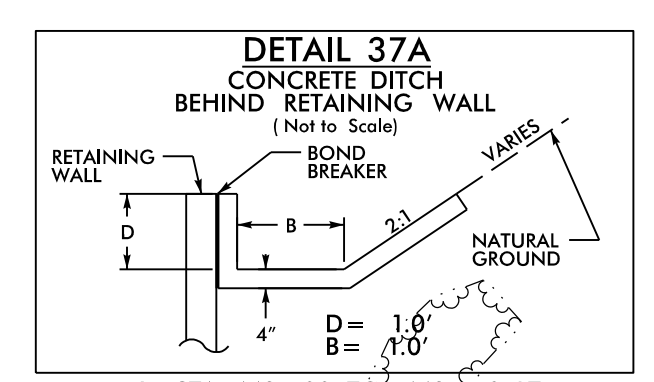

MATCH LINE STA -L- 442+00.00
MATCH TO SHEET UO-3

MATCH LINE STA -L- 456+00.00
MATCH TO SHEET UO-5

15-OCT-2022 09:07 U:\Utilities\Engineering\LIB0\Pro\A-A-0009CC-ut-rdy37-UO04_psh.dgn

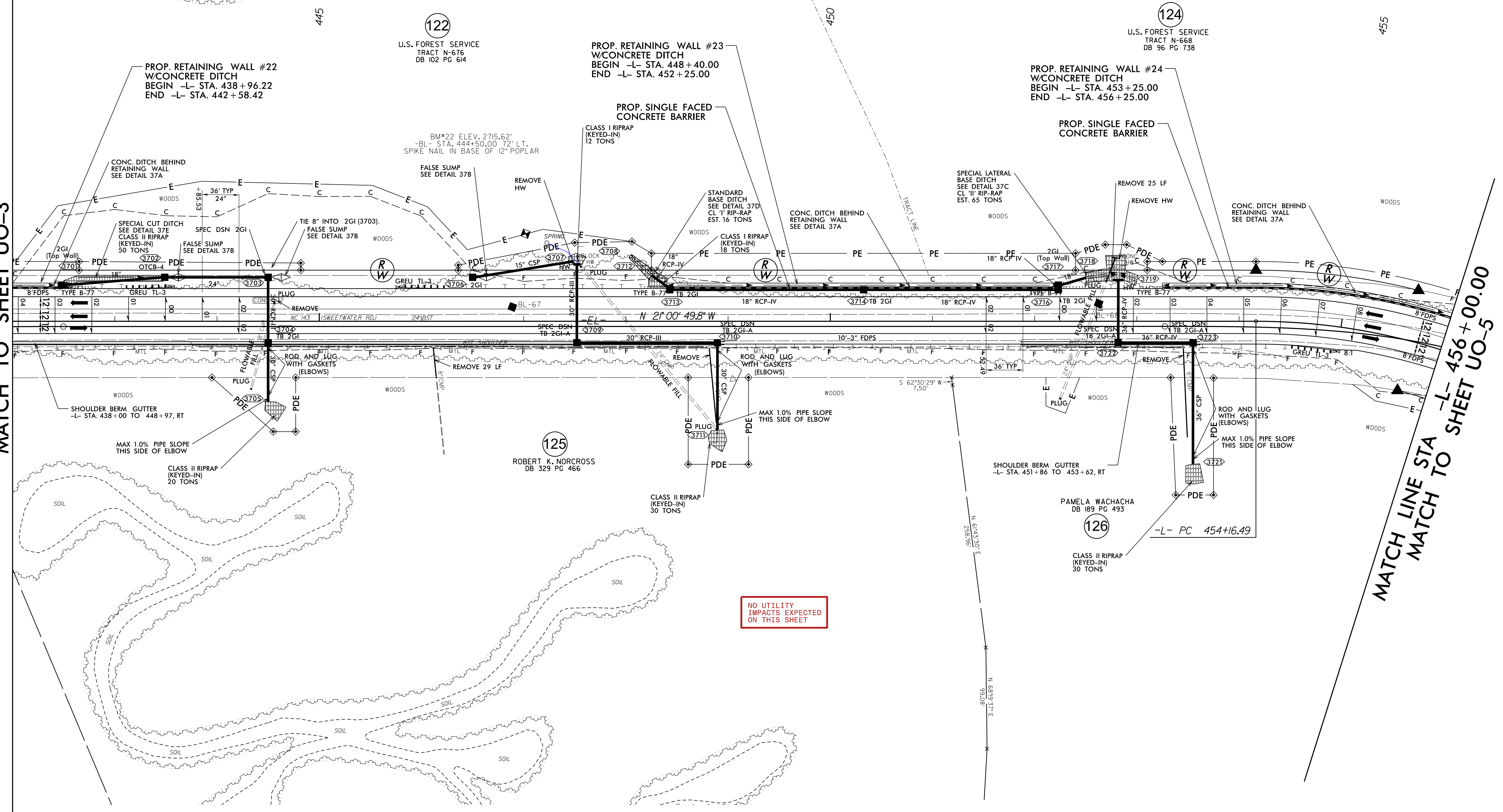

NO UTILITY IMPACTS EXPECTED ON THIS SHEET