

DETAIL No. 06000.07
SHEET 3 OF 3
EFFECTIVE: 12/01/18

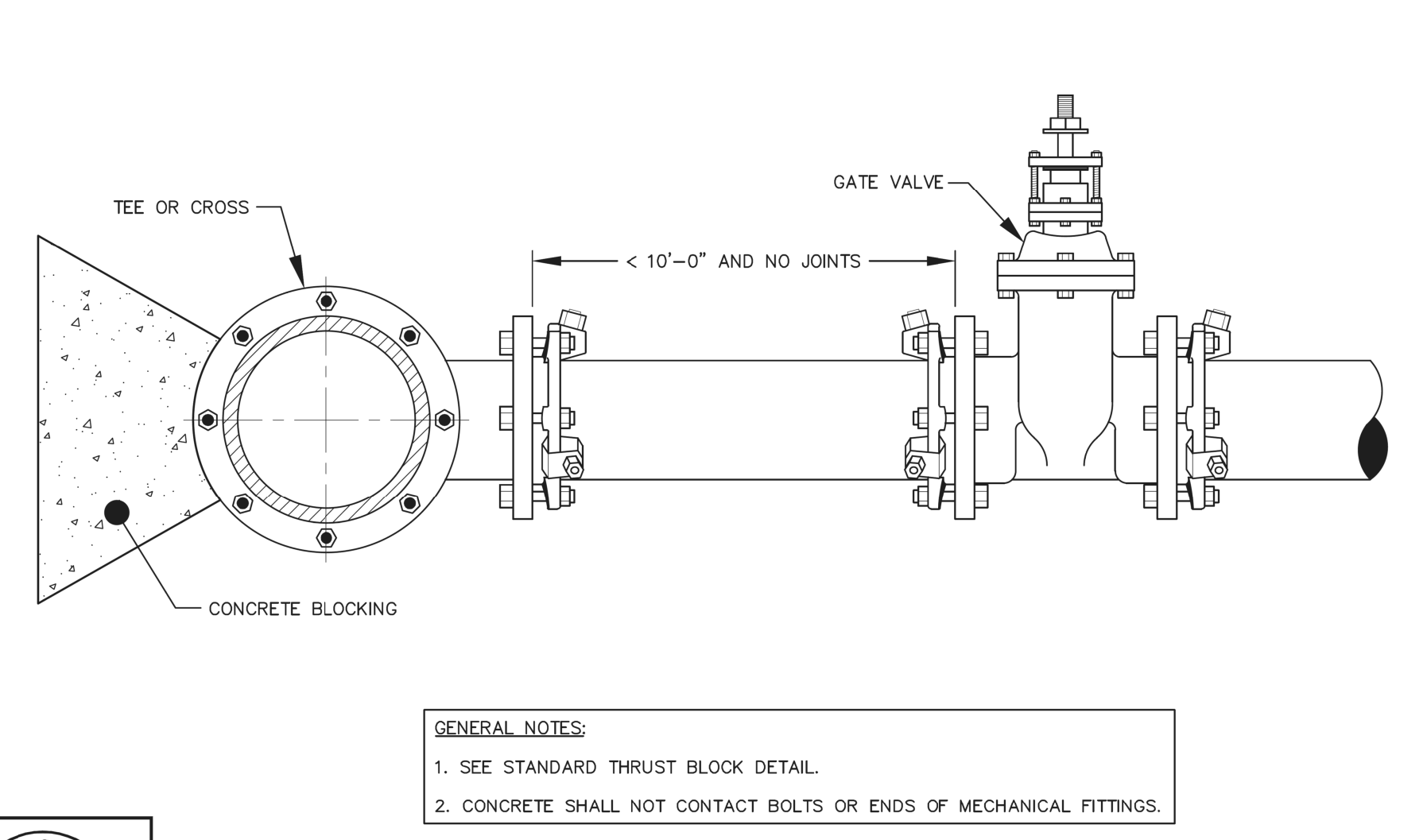

DETAIL No. 06000.08
SHEET 2 OF 2
EFFECTIVE: 12/01/18

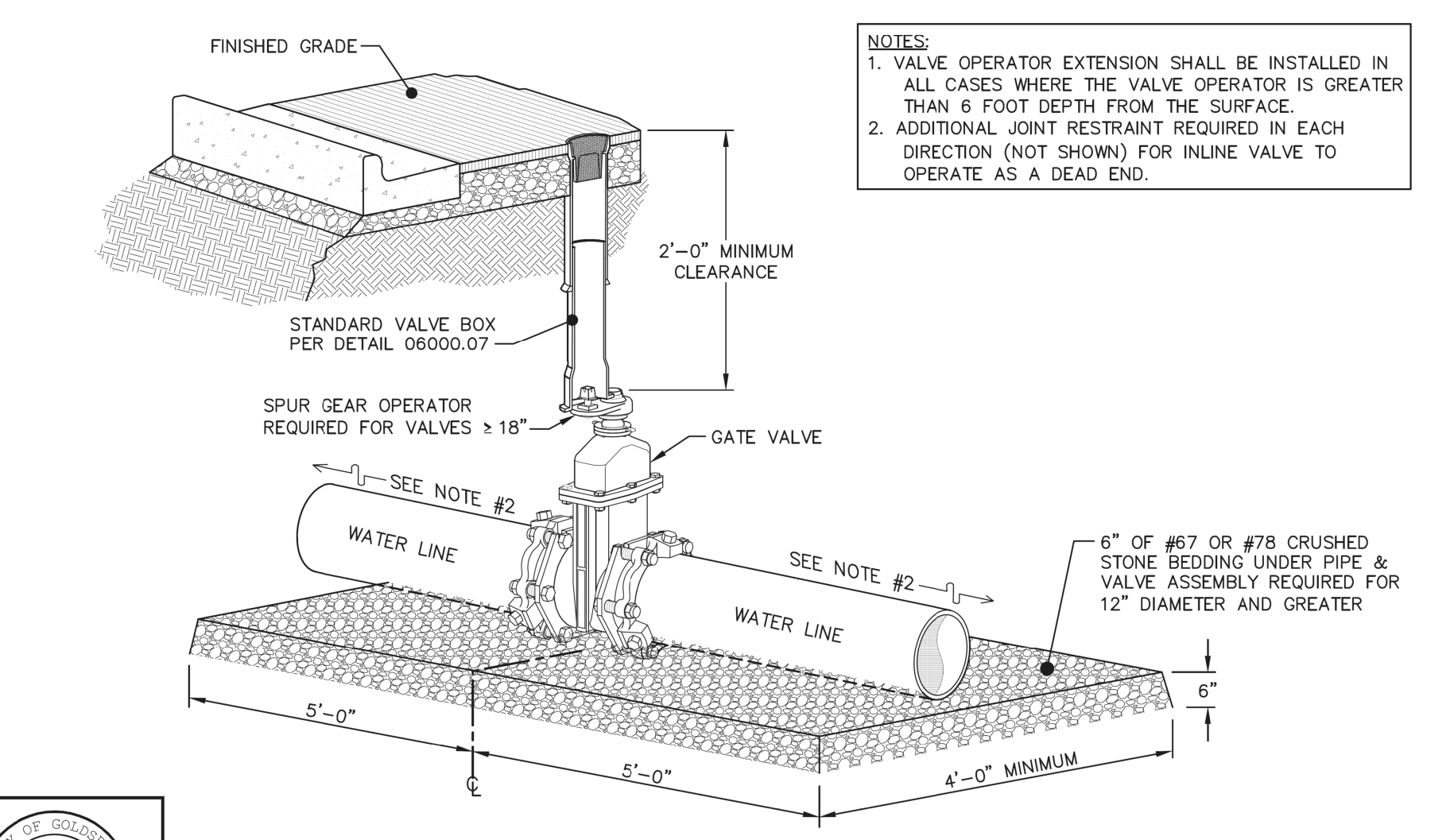

DETAIL No. 06000.09
SHEET 1 OF 2
EFFECTIVE: 12/01/18

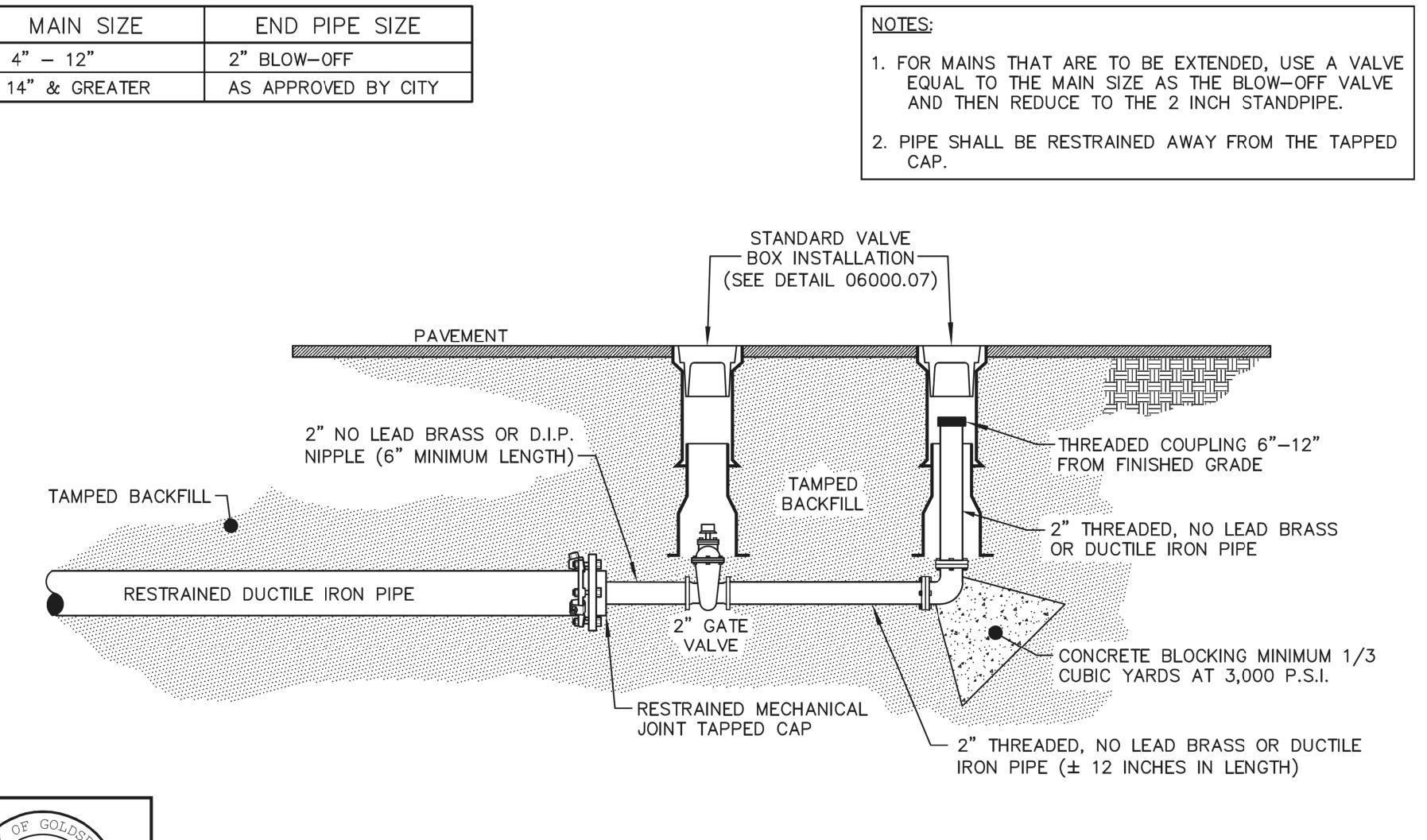

DETAIL No. 06000.10
SHEET 1 OF 1
EFFECTIVE: 12/01/18

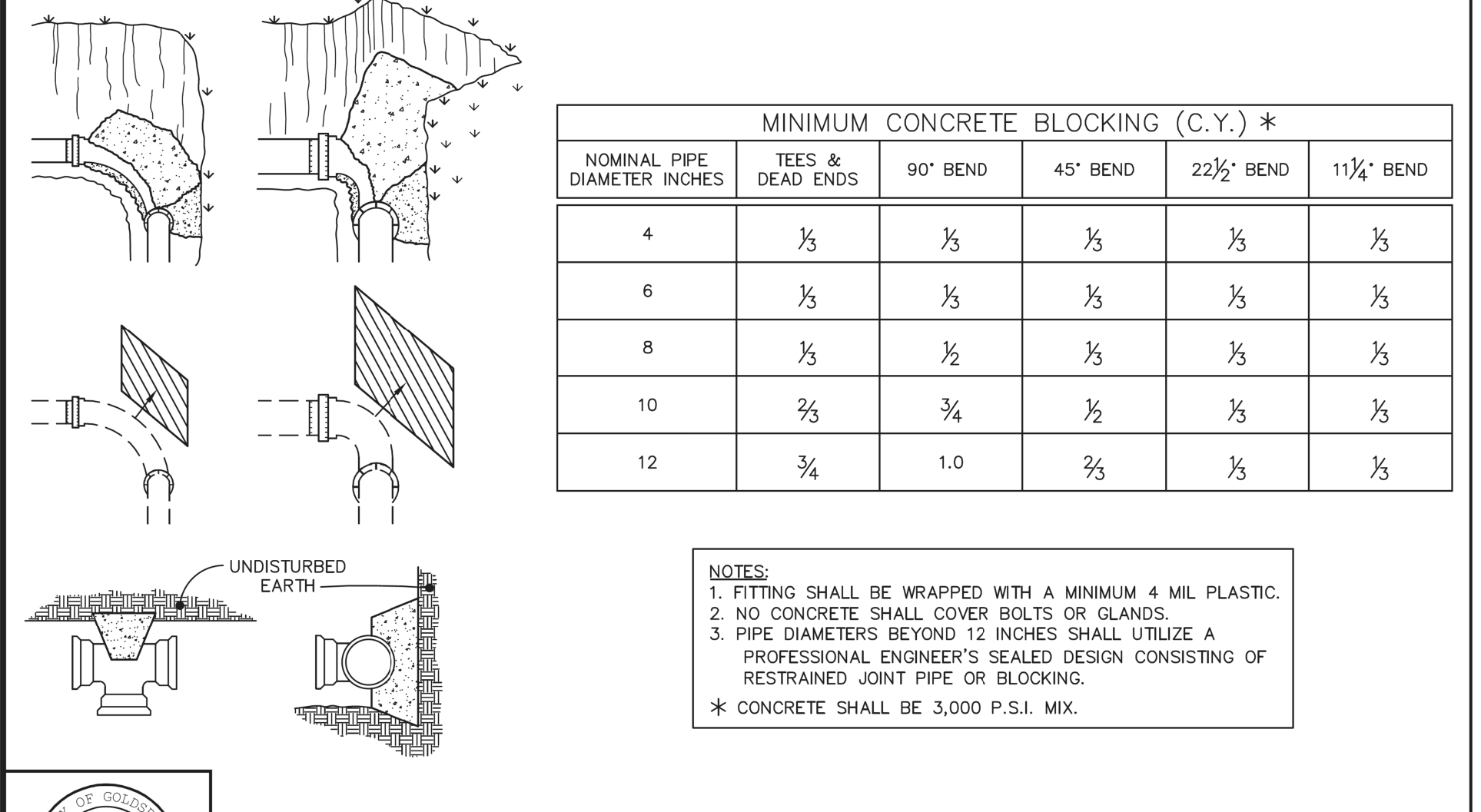

DETAIL No. 06000.12
SHEET 1 OF 1
EFFECTIVE: 12/01/18

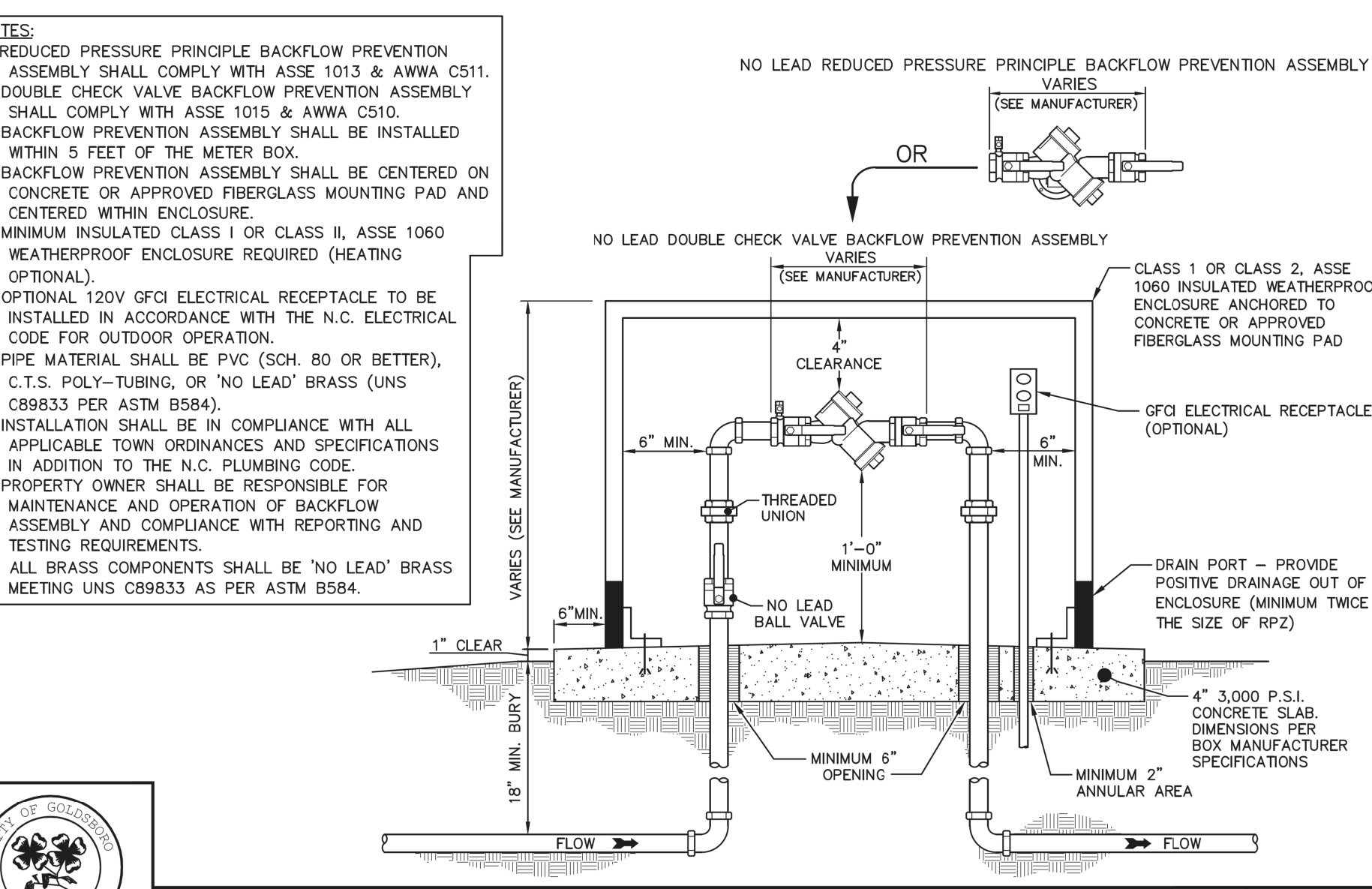

DETAIL No. 07000.03
SHEET 1 OF 1
EFFECTIVE: 12/01/18

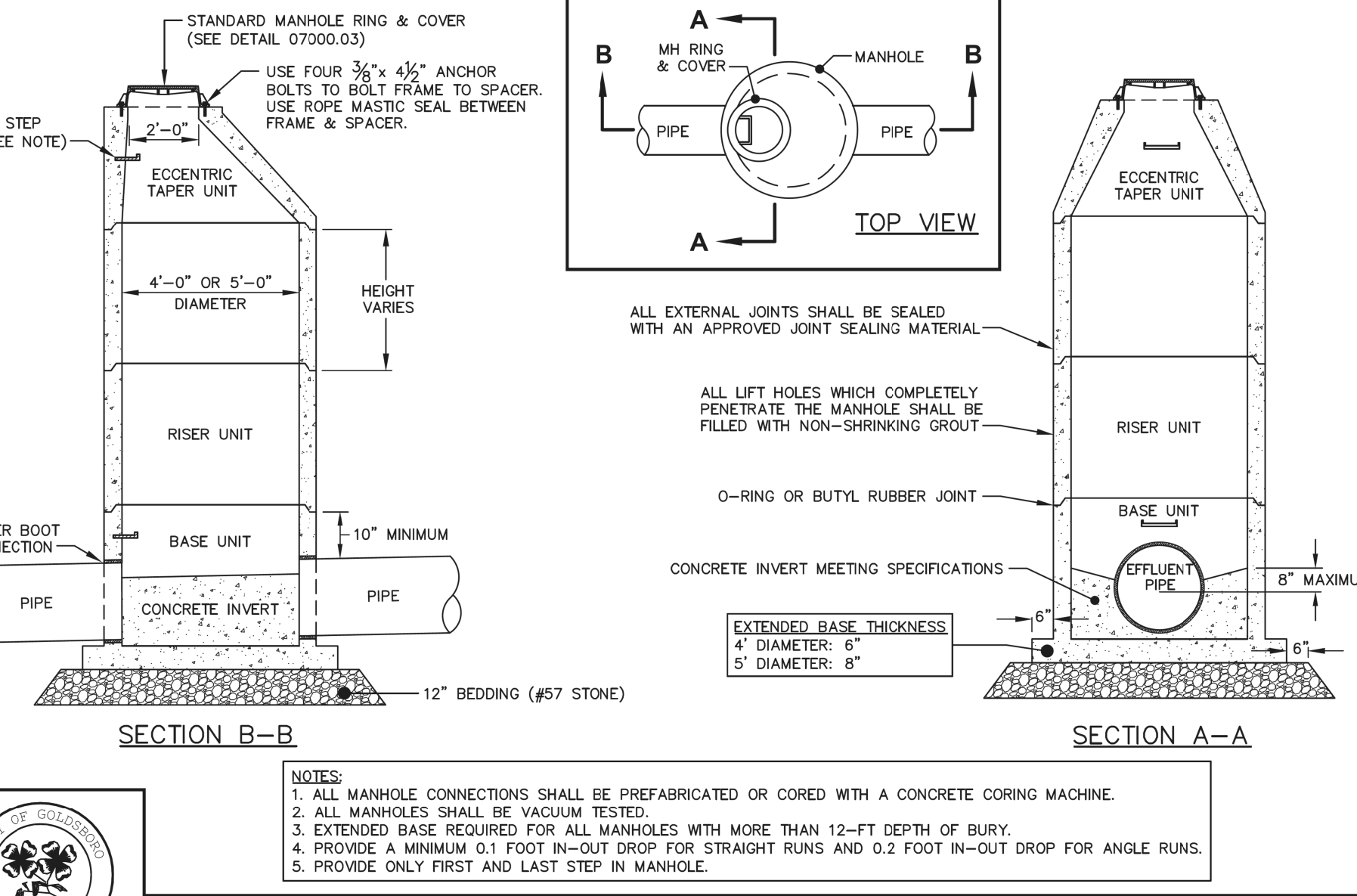

DETAIL No. 08000.01
SHEET 1 OF 4
EFFECTIVE: 12/01/18

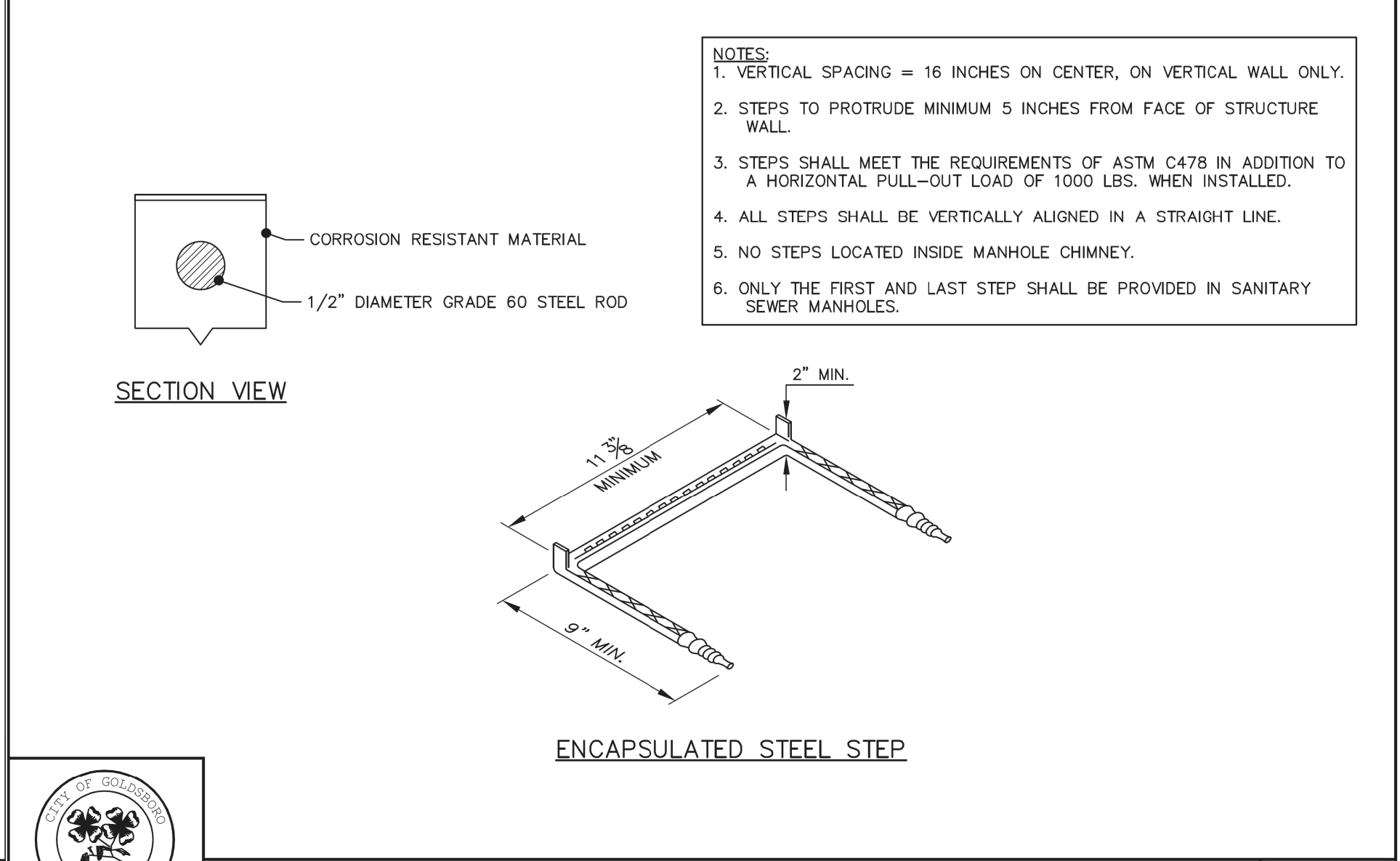

DETAIL No. 08000.01
SHEET 4 OF 4
EFFECTIVE: 12/01/18

REVISIONS

5/14/99