

EDI MODEL 2018ECL-NC CONFLICT MONITOR PROGRAMMING DETAIL

(remove jumpers and set switches as shown)

REMOVE DIODE JUMPERS: 1-5, 1-6, 1-9, 1-11, 1-15, 2-5, 2-6, 2-9, 2-11, 2-13, 2-15, 5-9, 5-11, 5-13, 6-9, 6-11, 6-13, 6-15, 9-11, 9-13, 9-15, 11-13, 11-15 and 13-15

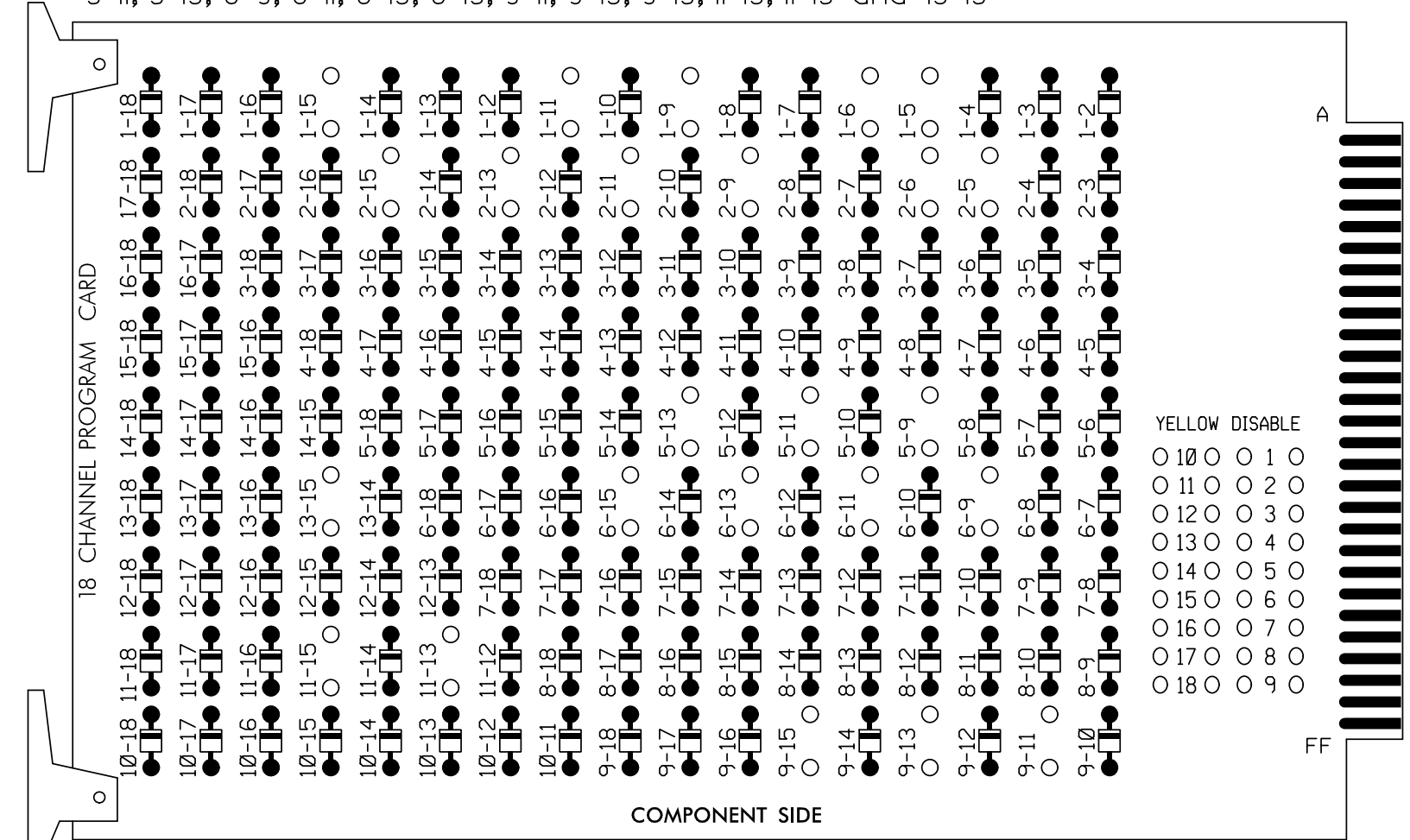

REMOVE JUMPERS AS SHOWN

NOTES:

- Card is provided with all diode jumpers in place. Removal of any jumper allows its channels to run concurrently.
- Ensure jumpers SEL2-SEL5 and SEL9 are present on the monitor board.
- Ensure that Red Enable is active at all times during normal operation.
- Connect serial cable from conflict monitor to comm. port 1 of 2070 controller. Ensure conflict monitor communicates with 2070.

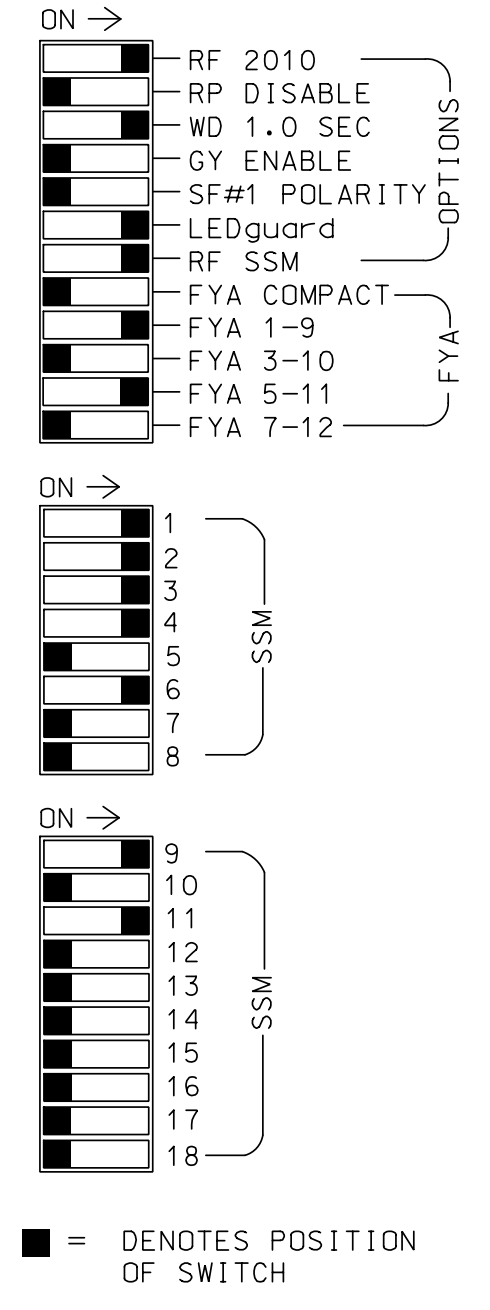
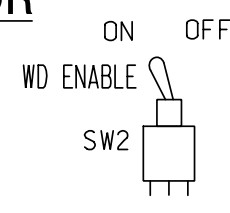

■ = DENOTES POSITION OF SWITCH

NOTES

- To prevent "flash-conflict" problems, insert red flash program blocks for all unused vehicle load switches in the output file. The installer shall verify that signal heads flash in accordance with the Signal Plans.
- Enable Simultaneous Gap-Out for all Phases.
- Program phases 2 and 6 for Variable Initial and Gap Reduction.
- Program phases 2 and 6 for Startup In Green.
- Program phases 2 and 6 for Startup Ped Call.
- Program phases 2 and 6 for Yellow Flash, and overlaps 1 and 2 as Wag Overlaps.
- The cabinet and controller are part of the Goldsboro Signal System.

EQUIPMENT INFORMATION

CONTROLLER.....2070
 CABINET.....332 W/ AUX
 SOFTWARE.....ECONOLITE OASIS
 CABINET MOUNT.....BASE
 OUTPUT FILE POSITIONS...18 WITH AUX. OUTPUT FILE
 LOAD SWITCHES USED.....S1,S2,S3,S4,S5,S7,S8,S9,AUX S1,AUX S4
 PHASES USED.....1,2,2PED,3,4,5,6,6PED
 OVERLAP "A".....1+2
 OVERLAP "B".....NOT USED
 OVERLAP "C".....5+6
 OVERLAP "D".....NOT USED

SIGNAL HEAD HOOK-UP CHART

LOAD SWITCH NO.	S1	S2	S3	S4	S5	S6	S7	S8	S9	S10	S11	S12	AUX S1	AUX S2	AUX S3	AUX S4	AUX S5	AUX S6	
CMU CHANNEL NO.	1	2	13	3	4	14	5	6	15	7	8	16	9	10	17	11	12	18	
PHASE	1	2	2 PED	3	4	4 PED	5	6	6 PED	7	8	8 PED	OLA	OLB	SPARE	OLC	OLD	SPARE	
SIGNAL HEAD NO.	11	32	21,22	P21, P22	31	32	41	42	NU	51	61,62	P61, P62	NU	NU	NU	11	NU	51	NU
RED		*	128	116	116	101	101				134								
YELLOW			129	117	117	102	102		*		135								
GREEN			130	118	118	103	103				136								
RED ARROW																A121		A114	
YELLOW ARROW		126														A122		A115	
FLASHING YELLOW ARROW																A123		A116	
GREEN ARROW	127	127			118	103			133										
Hand icon					113													119	
Person icon					115													121	

NU = Not Used

* Denotes install load resistor. See load resistor installation detail this sheet.

★ See pictorial of head wiring in detail this sheet.

INPUT FILE POSITION LAYOUT

(from view)

FILE	1	2	3	4	5	6	7	8	9	10	11	12	13	14
U	∅ 1	∅ 1	∅ 2	∅ 3	∅ 4	∅ 5	∅ 6	∅ 7	∅ 8	∅ 9	∅ 10	∅ 11	∅ 12	∅ 13
L	1A	1B	2A	3A	4A	5A	6A	7A	8A	9A	10A	11A	12A	13A
U	NOT USED	NOT USED	∅ 2	∅ 3	∅ 4	∅ 5	∅ 6	∅ 7	∅ 8	∅ 9	∅ 10	∅ 11	∅ 12	∅ 13
L	5A	6A	2B	3B	4B	5B	6B	7B	8B	9B	10B	11B	12B	13B
U	NOT USED	∅ 6	∅ 7	∅ 8	∅ 9	∅ 10	∅ 11	∅ 12	∅ 13	∅ 14	∅ 15	∅ 16	∅ 17	∅ 18
L	6B	7B	8B	9B	10B	11B	12B	13B	14B	15B	16B	17B	18B	19B

EX.: 1A, 2A, ETC. = LOOP NO.'S
 FS = FLASH SENSE
 ST = STOP TIME

⊗ Wired Input - Do not populate slot with detector card

INPUT FILE CONNECTION & PROGRAMMING CHART

LOOP NO.	LOOP TERMINAL	INPUT FILE POS.	PIN NO.	INPUT ASSIGNMENT NO.	DETECTOR NO.	NEMA PHASE	CALL	EXTEND	FULL TIME DELAY	STRETCH TIME	DELAY TIME
1A ¹	TB2-1,2	I1U	56	18	1	1	Y	Y			15
	-	J4U	48	10★	26	6	Y	Y	Y		3
	-	I1U	56	18★	51	1	Y	Y			3
1B	TB2-5,6	I2U	39	1	2	1	Y	Y			
2A	TB2-9,10	I3U	63	25	32	2	Y	Y			
2B	TB2-11,12	I3L	76	38	42	2	Y	Y			
3A	TB4-5,6	I5U	58	20	3	3	Y	Y			3
4A	TB4-9,10	I6U	41	3	4	4	Y	Y			5
5A ²	TB3-1,2	J1U	55	17	5	5	Y	Y			15
	-	I4U	47	9★	22	2	Y	Y	Y		3
	-	J1U	55	17★	55	5	Y	Y			3
6A	TB3-5,6	J2U	40	2	6	6	Y	Y			
6B	TB3-7,8	J2L	44	6	16	6	Y	Y			
PED PUSH BUTTONS											
P21,P22	TB8-4,6	I12U	67	29					2 PED		
P61,P62	TB8-7,9	I13U	68	30					6 PED		

NOTE:
 INSTALL DC ISOLATORS IN INPUT FILE SLOTS 112 AND 113.

- Add jumper from I1-W to J4-W, on rear of input file.
 - Add jumper from J1-W to I4-W, on rear of input file.
- ★ See Input Page Assignment programming details on sheets 3 and 4.
 * System detector only. Remove the vehicle phase assigned to this detector in the default programming.

INPUT FILE POSITION LEGEND: J2L

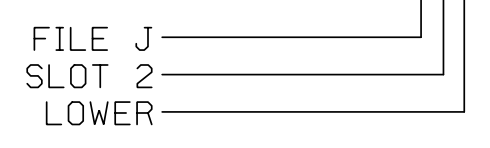

LOAD RESISTOR INSTALLATION DETAIL

(install resistors as shown below)

VALUE (ohms)	WATTAGE
1.5K - 1.9K	25W (min)
2.0K - 3.0K	10W (min)

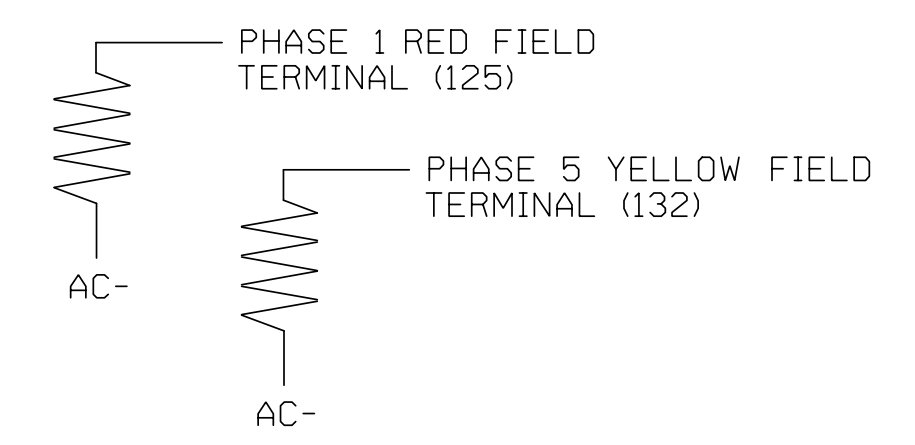

FYA SIGNAL WIRING DETAIL

(wire signal heads as shown)

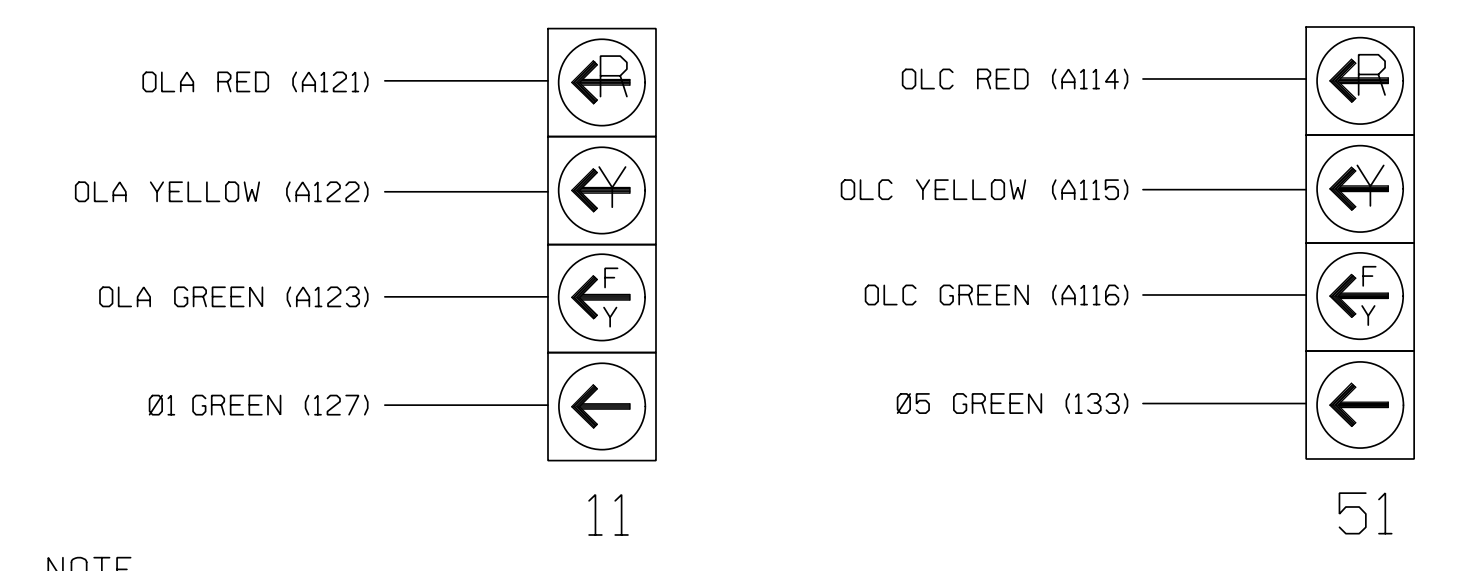

NOTE

The sequence display for signal heads 11 and 51 requires special logic programming. See sheet 2 for programming instructions.

COUNTDOWN PEDESTRIAN SIGNAL OPERATION

Countdown Ped Signals are required to display timing only during Ped Clearance Interval. Consult Ped Signal Module user's manual for instructions on selecting this feature.

THIS ELECTRICAL DETAIL IS FOR THE SIGNAL DESIGN: 04-1444
 DESIGNED: NOVEMBER 2019
 SEALED: 6/30/20
 REVISED: N/A

Electrical Detail - Sheet 1 of 5

Prepared For:

 750 N. Greenfield Pkwy, Garner, NC 27529

US 13 (BERKELEY BOULEVARD) AT FALLIN BOULEVARD AND HILL DRIVE CIRCLE

DIVISION 4 WAYNE COUNTY GOLDSBORO
 PLAN DATE: NOVEMBER 2019 REVIEWED BY: SL PHILLIPS
 PREPARED BY: SP PENNINGTON REVIEWED BY:

REVISIONS	INIT.	DATE

DOCUMENT NOT CONSIDERED FINAL UNLESS ALL SIGNATURES COMPLETED

SEAL

 Stacie L. Phillips
 6/30/2020
 DATE

PLANS PREPARED IN THE OFFICE OF:
KimleyHorn
 NC License #F-0102
 421 Fayetteville Street, Suite 600
 Raleigh, NC 27601
 (919) 617-2000