



5/14/19

REVISIONS

PROJECT REFERENCE NO.		SHEET NO.	
U-5724		2D-1	
R/W SHEET NO.			
ROADWAY DESIGN ENGINEER		HYDRAULICS ENGINEER	
			
DOCUMENT NOT CONSIDERED FINAL UNLESS ALL SIGNATURES COMPLETED			

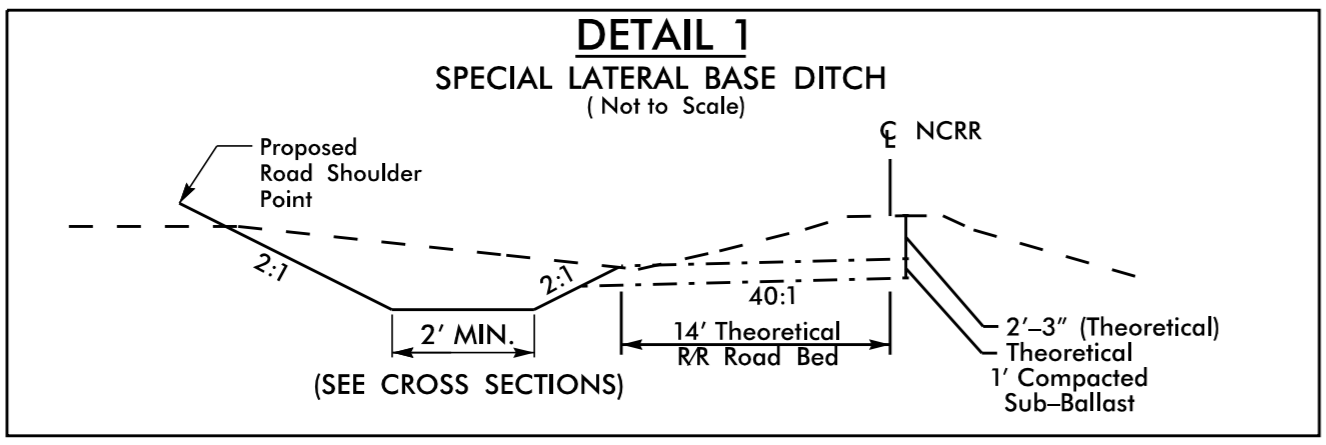

FROM STA. 18+00 TO STA. 25+50 -L- (RT)
FROM STA. 27+35 TO STA. 42+00 -L- (RT)

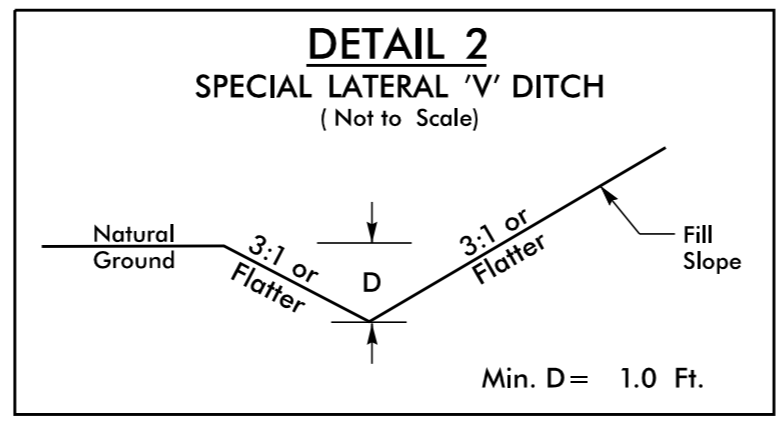

FROM STA. 18+00 TO STA. 18+70 -L- (LT)
FROM STA. 19+50 TO STA. 20+25 -L- (LT)
FROM STA. 20+25 TO STA. 21+00 -L- (LT)
FROM STA. 24+50 TO STA. 25+00 -L- (LT)
FROM STA. 25+00 TO STA. 25+50 -L- (LT)
FROM STA. 43+25 TO STA. 47+50 -L- (RT)
FROM STA. 47+85 TO STA. 48+25 -L- (RT)
FROM STA. 48+60 TO STA. 49+50 -L- (RT)
FROM STA. 49+50 TO STA. 50+25 -L- (RT)
FROM STA. 50+60 TO STA. 51+30 -L- (RT)
FROM STA. 51+30 TO STA. 51+60 -L- (RT)
FROM STA. 53+50 TO STA. 57+50 -L- (LT)
FROM STA. 53+44 TO STA. 58+00 -L- (RT)
FROM STA. 10+66 TO STA. 13+50 -Y2- (RT)
FROM STA. 17+87 TO STA. 20+75 -Y2- (RT)
FROM STA. 19+93 TO STA. 21+00 -Y2- (LT)

FROM STA. 24+00 TO STA. 27+68 -Y2- (LT)
FROM STA. 29+60 TO STA. 29+90 -Y2- (LT)
FROM STA. 29+90 TO STA. 31+00 -Y2- (LT)
FROM STA. 29+90 TO STA. 34+00 -Y2- (RT)
FROM STA. 34+00 TO STA. 34+58 -Y2- (LT)
FROM STA. 54+05 TO STA. 55+75 -Y2- (RT)
FROM STA. 15+45 TO STA. 16+85 -Y3- (LT)
FROM STA. 18+00 TO STA. 21+25 -Y3- (LT)
FROM STA. 21+25 TO STA. 22+30 -Y3- (LT)
FROM STA. 22+60 TO STA. 24+80 -Y3- (LT)
FROM STA. 12+00 TO STA. 12+20 -Y5- (RT)
FROM STA. 12+70 TO STA. 13+00 -Y5- (RT)
FROM STA. 12+00 TO STA. 12+16 -Y5- (LT)
FROM STA. 12+68 TO STA. 14+00 -Y5- (LT)

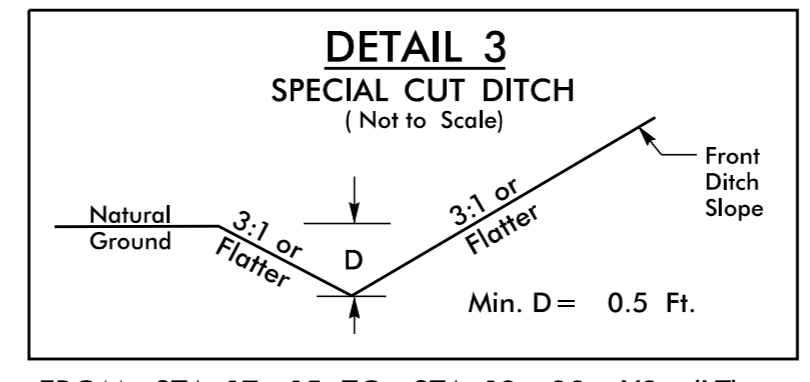

FROM STA. 17+15 TO STA. 18+00 -Y3- (LT)

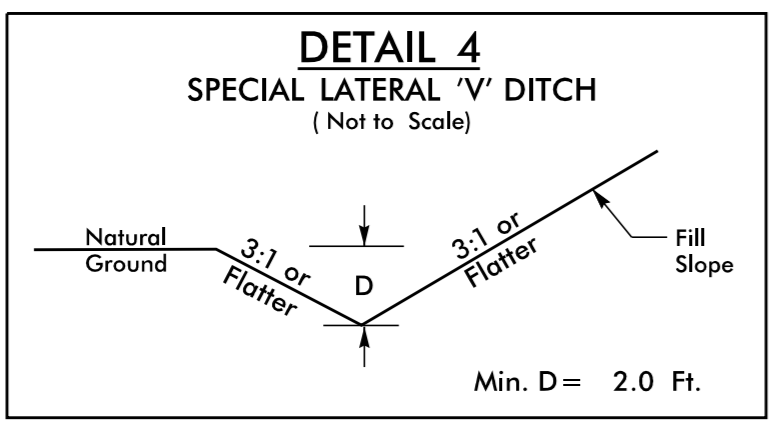

FROM STA. 14+00 TO STA. 17+87 -Y2- (RT)
FROM STA. 21+75 TO STA. 23+25 -Y2- (LT)

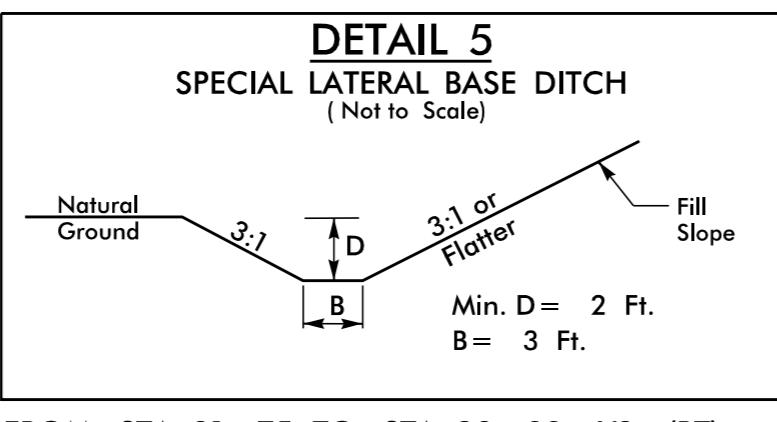

FROM STA. 21+75 TO STA. 29+00 -Y2- (RT)

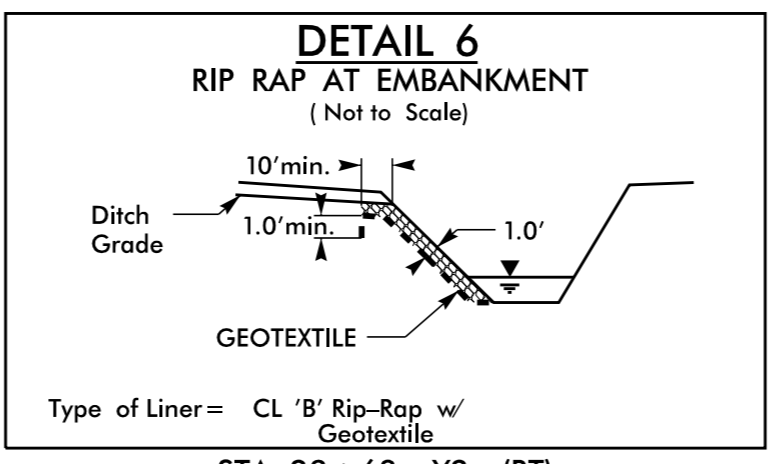

STA. 29+68 -Y2- (RT)

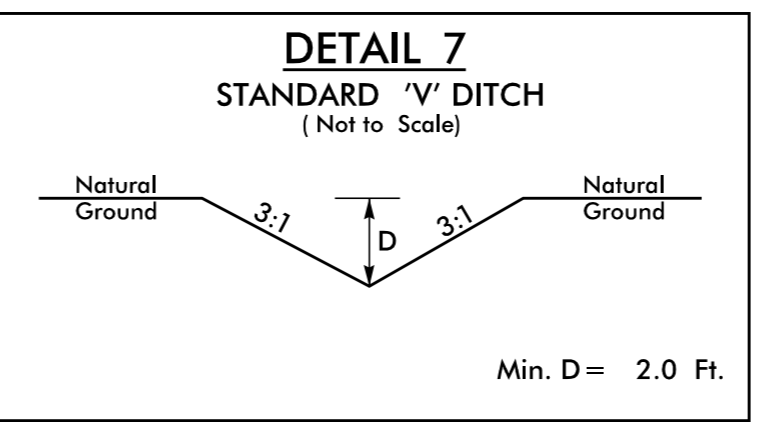

FROM STA. 29+68 TO STA. 29+90 -Y2- (RT)
FROM STA. 10+20 TO STA. 11+96 -Y4- (LT)

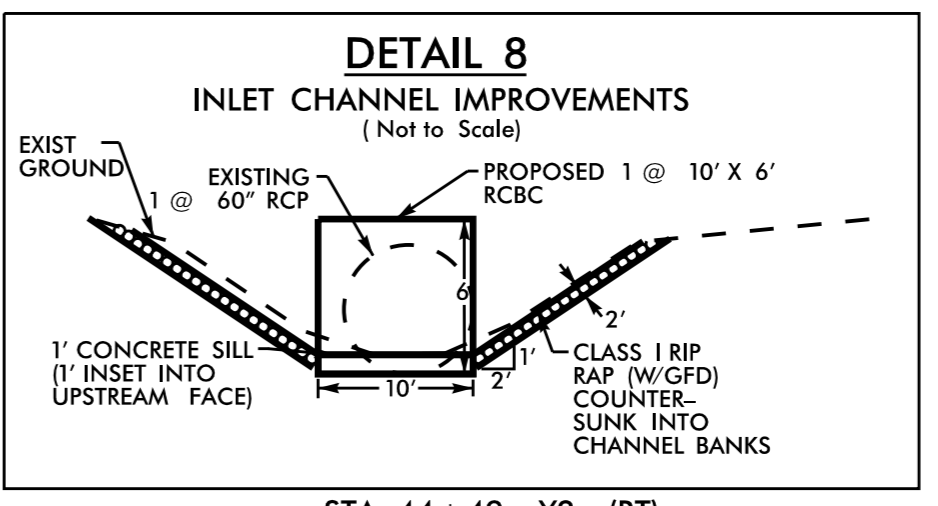

STA. 44+49 -Y2- (RT)

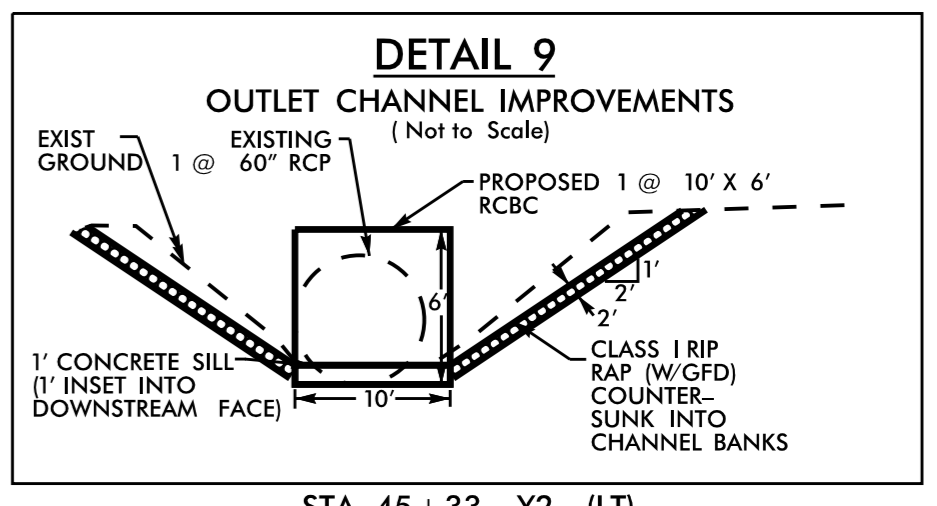

STA. 45+33 -Y2- (LT)

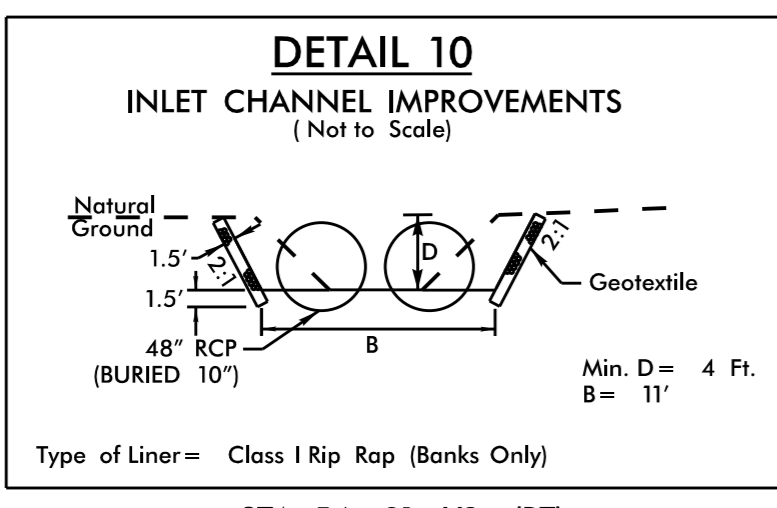

STA. 54+01 -Y2- (RT)

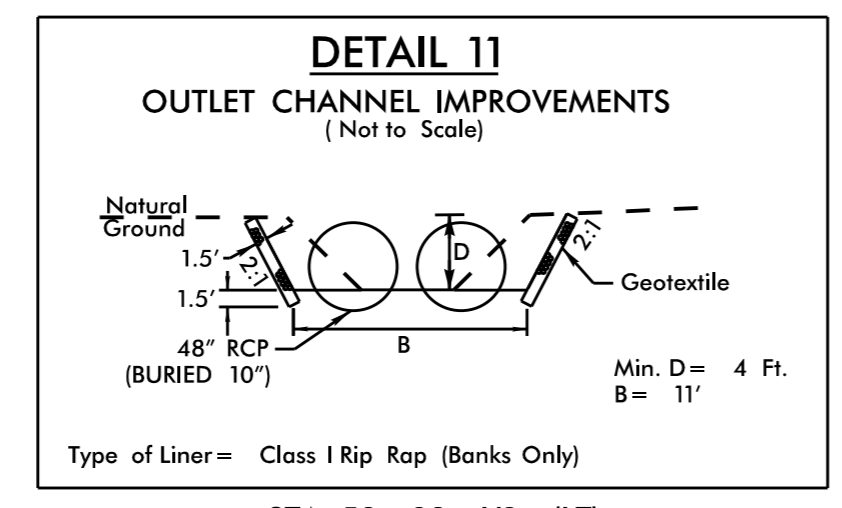

STA. 53+98 -Y2- (LT)

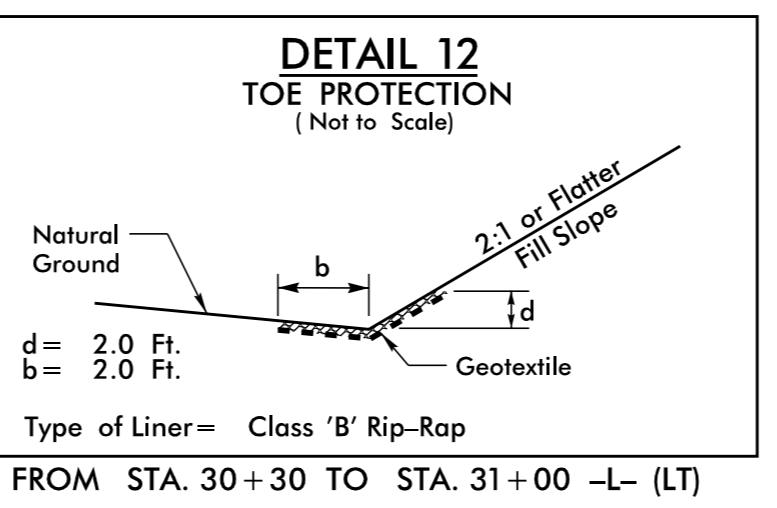

FROM STA. 30+30 TO STA. 31+00 -L- (LT)

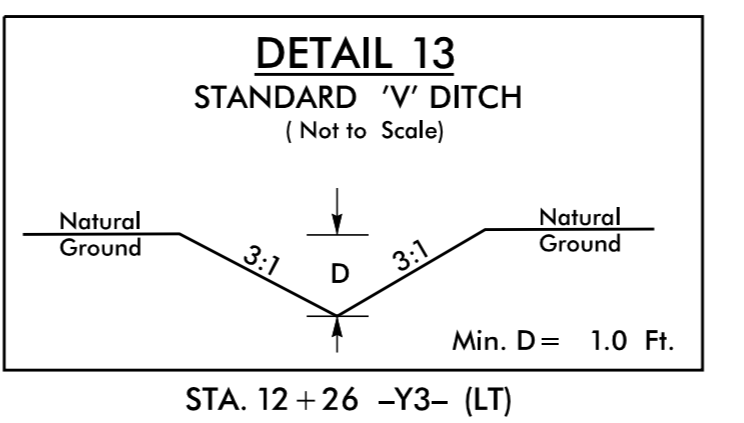

STA. 12+26 -Y3- (LT)

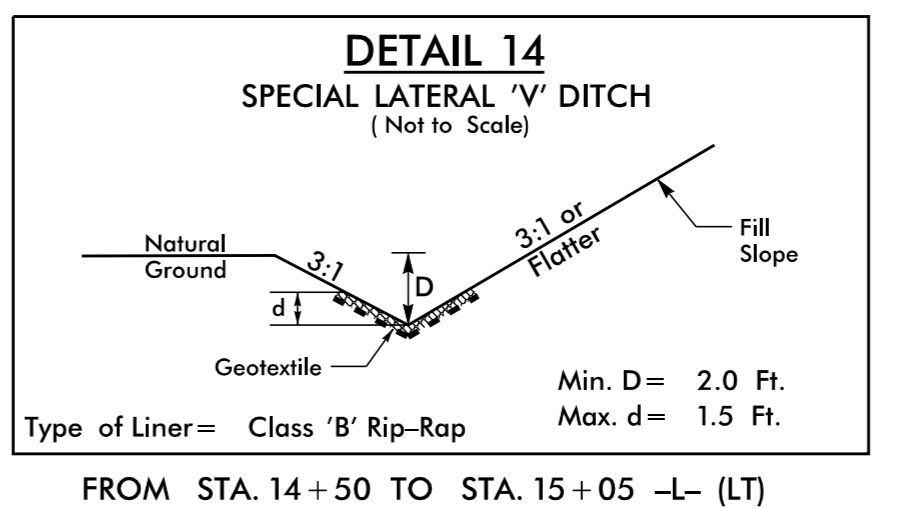

FROM STA. 14+50 TO STA. 15+05 -L- (LT)

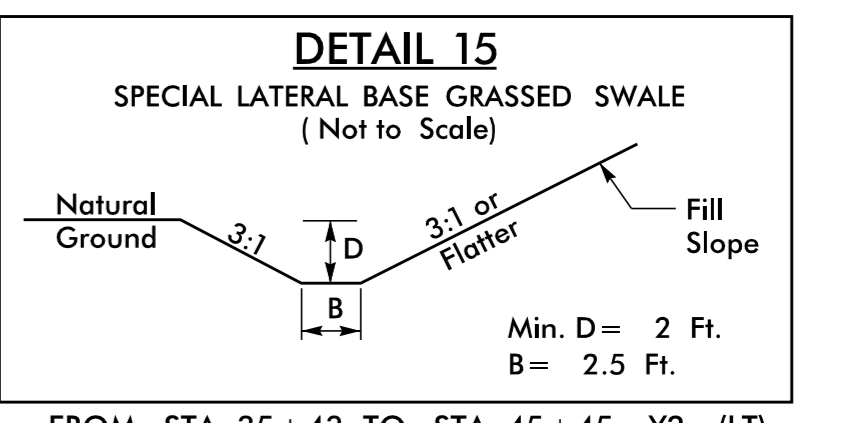

FROM STA. 35+43 TO STA. 45+45 -Y2- (LT)

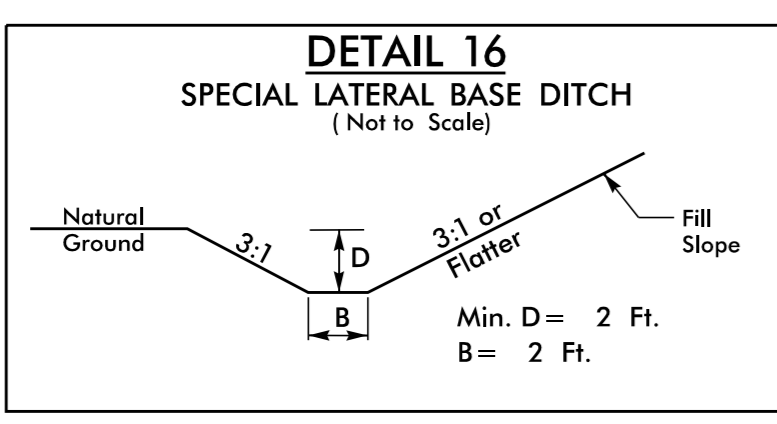

FROM STA. 12+54 TO STA. 19+80 -Y2- (LT)

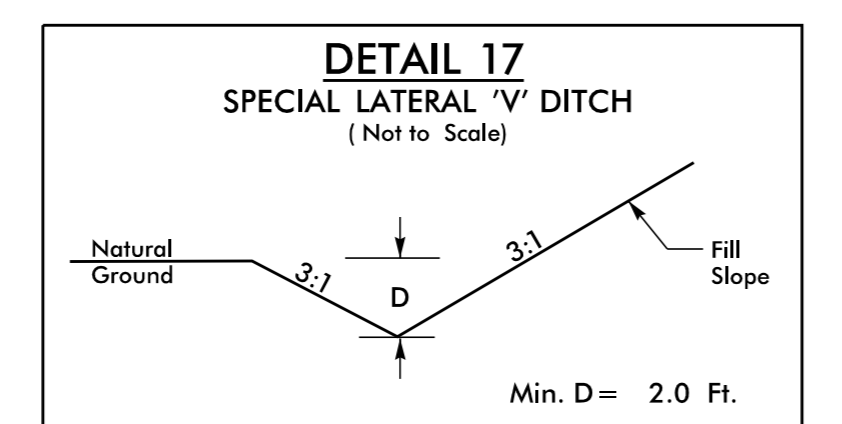

FROM STA. 10+50 TO STA. 14+92 -Y3- (RT)
FROM STA. 14+00 TO STA. 14+94 -Y3- (LT)

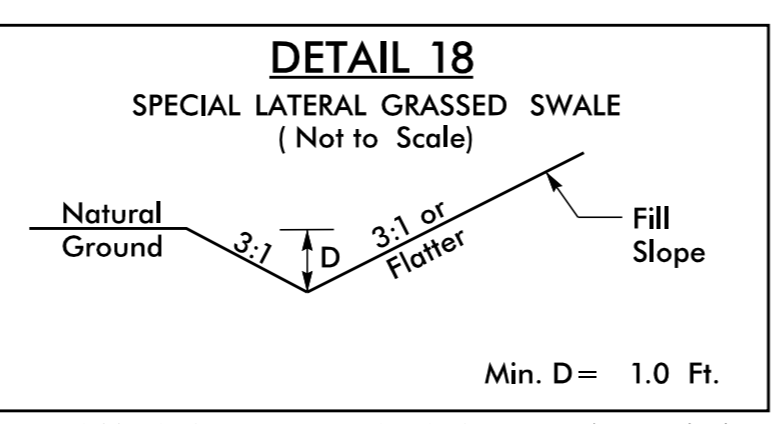

FROM STA. 40+00 TO STA. 44+36 -L- (LT)
FROM STA. 45+60 TO STA. 48+06 -Y2- (LT)
FROM STA. 53+00 TO STA. 53+88 -Y2- (LT)
FROM STA. 54+05 TO STA. 55+39 -Y2- (LT)

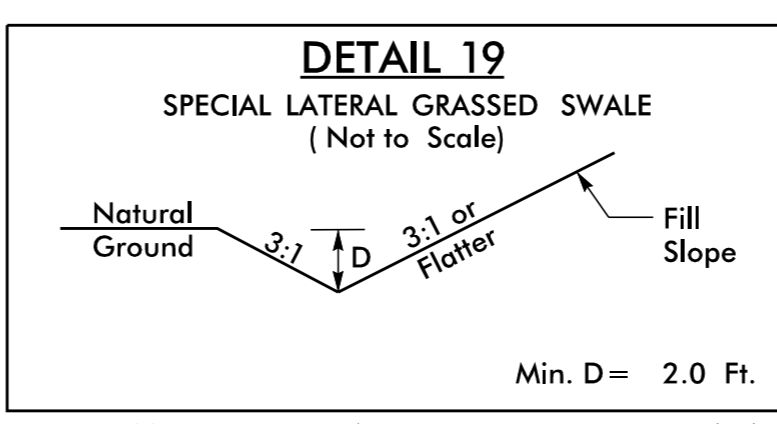

FROM STA. 44+36 TO STA. 51+40 -L- (LT)
FROM STA. 35+43 TO STA. 44+25 -Y2- (RT)

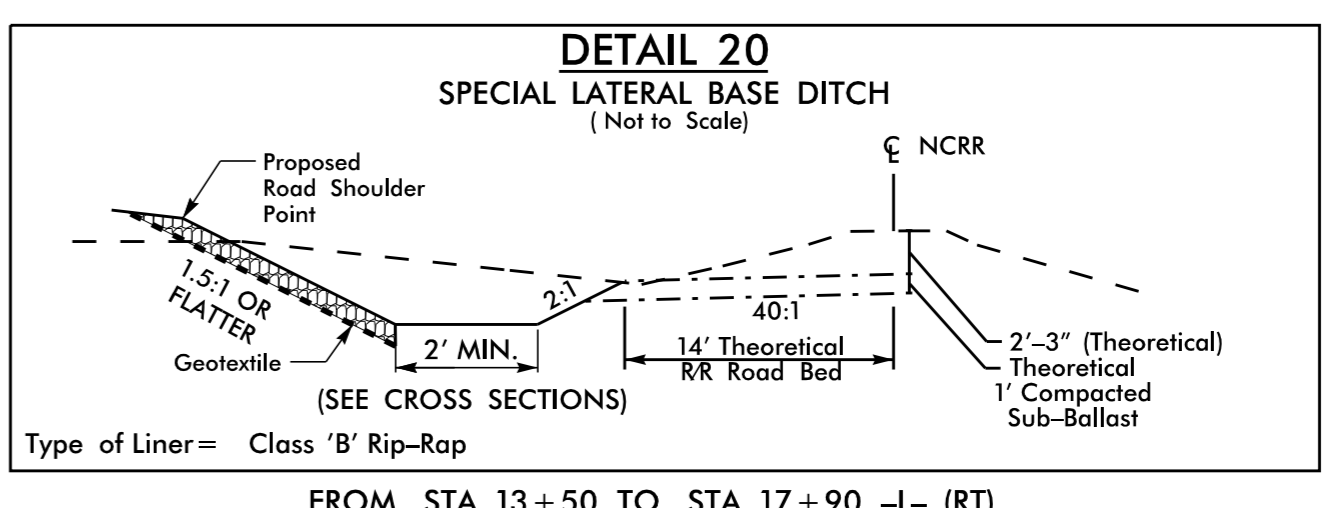

FROM STA. 13+50 TO STA. 17+90 -L- (RT)

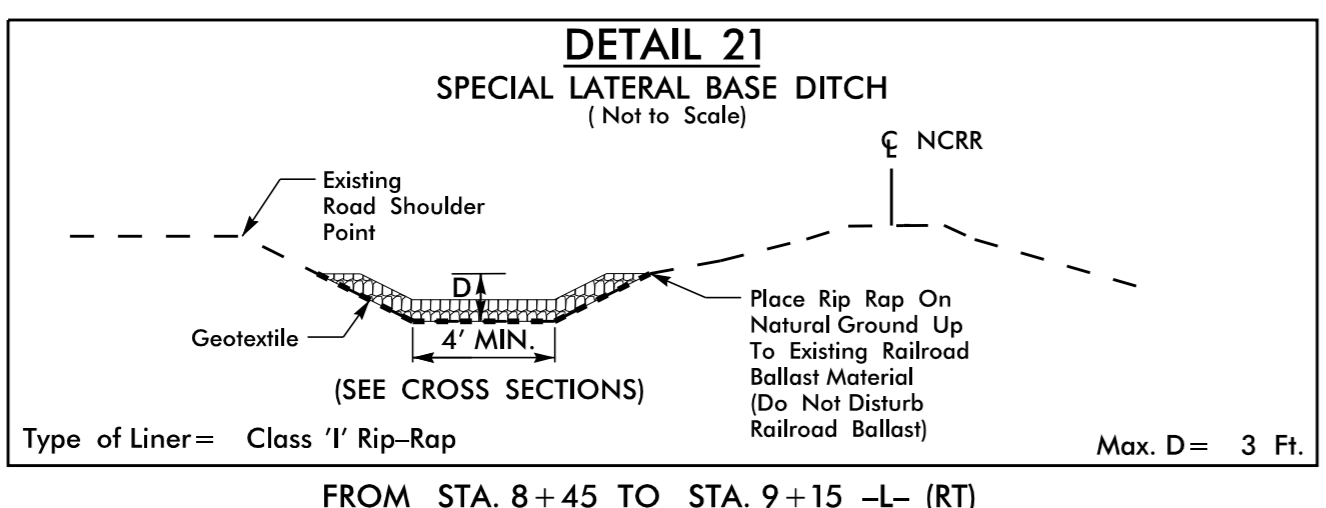

FROM STA. 8+45 TO STA. 9+15 -L- (RT)

K:\PAL_Roadway\01036333 - U-5724 - Central Heights\Roadway\Pro\U-5724_rdy_hyp.dgn

10/12/2022