

10

15

20

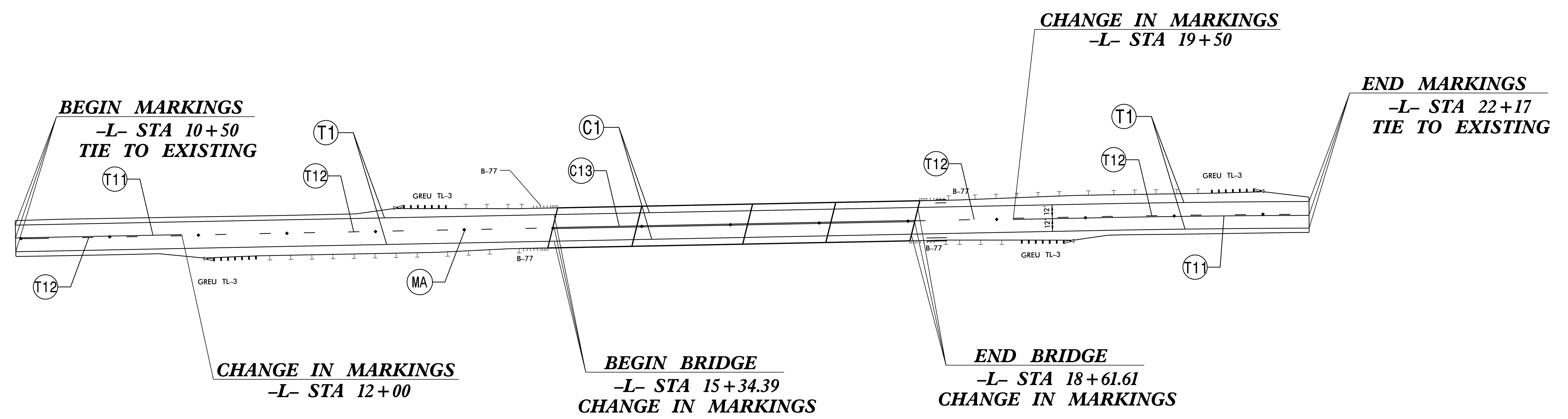

I6-AUG-2022 08:55
 N:\2016\201601945_23 B-5670\TrafficControl\TCP\B5670_PMP_02.dgn
 \$\$\$\$SERIALNAME\$\$\$\$

PAVEMENT MARKING LEGEND	
(T1)	WHITE EDGELINE (4", 90 MILS)
(T11)	YELLOW SINGLE CENTER (4", 90 MILS)
(T12)	10-FOOT YELLOW SKIP (4", 90 MILS)
(C1)	WHITE EDGELINE, COLD APPLIED (4", TYPE 1)
(C13)	YELLOW DOUBLE CENTER, COLD APPLIED (4", TYPE 1)
(MA)	PERMANENT RAISED MARKER, YELLOW AND YELLOW

PAVEMENT MARKING DETAIL