

8/25/2022 2:05:23 PM P:\Raleigh\Projects\2015\Y-4810K (NCDOT RailDiv)\Structures\Drawings\Final\Y4810K_SMU_AS.dgn

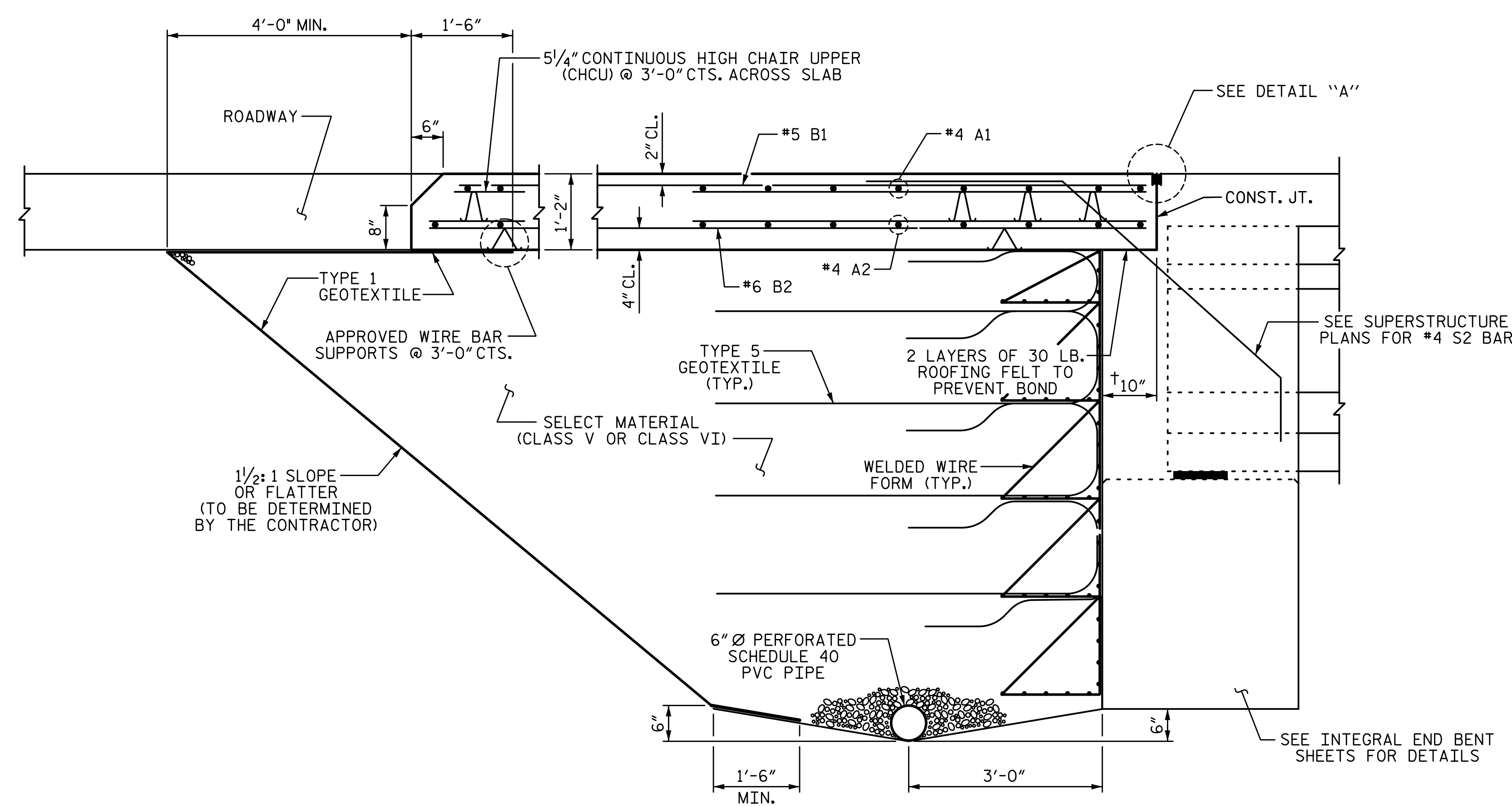

SECTION THRU SLAB (TYPE A - ALTERNATE APPROACH FILL)

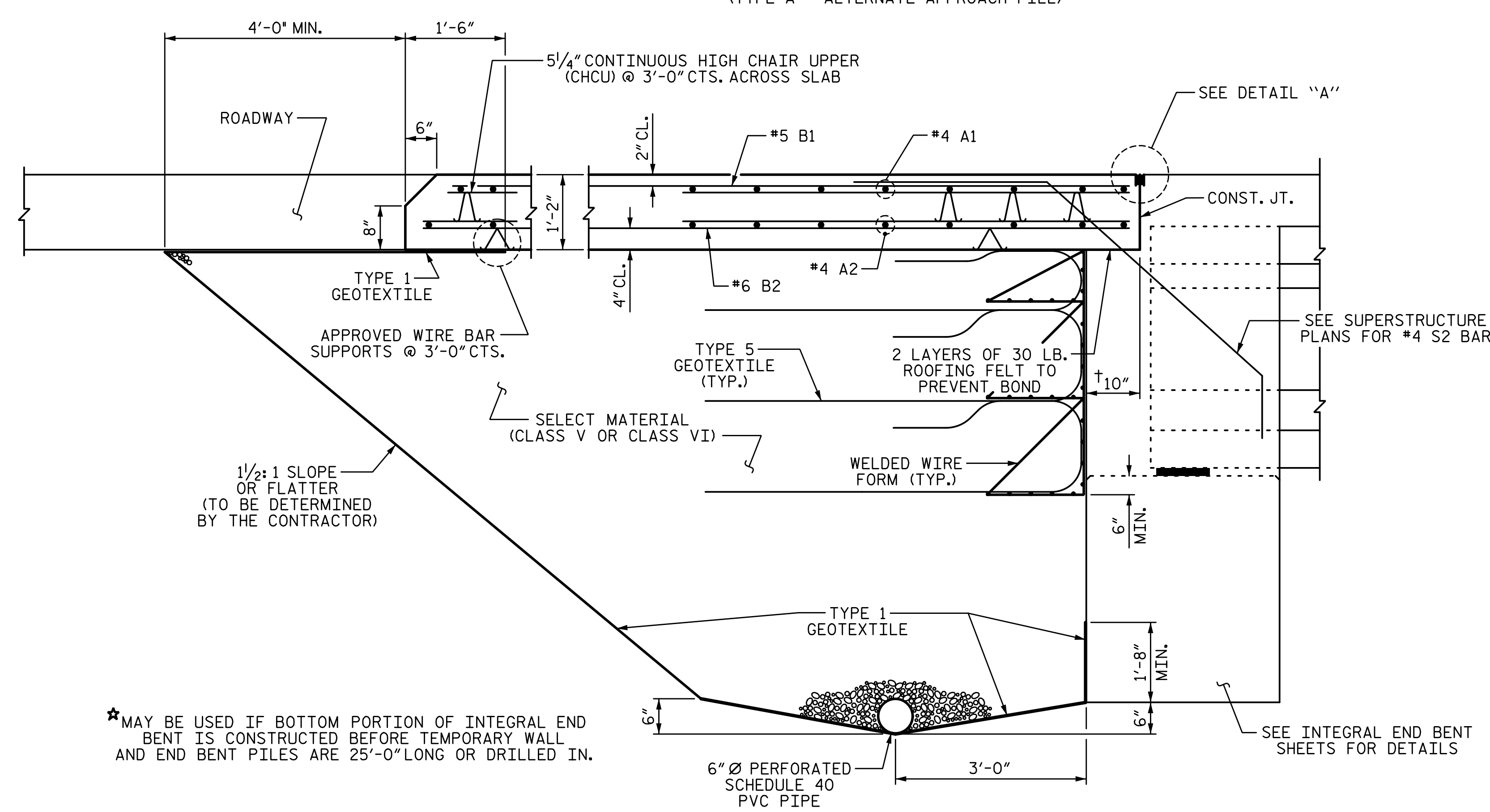

SECTION THRU SLAB (TYPE A - ALTERNATE APPROACH FILL)

*MAY BE USED IF BOTTOM PORTION OF INTEGRAL END BENT IS CONSTRUCTED BEFORE TEMPORARY WALL AND END BENT PILES ARE 25'-0" LONG OR DRILLED IN.

NOTES:

APPROACH SLAB SHALL NOT BE CONSTRUCTED PRIOR TO COMPLETION OF THE BRIDGE DECK.

FOR TEMPORARY GEOTEXTILE WALL INCLUDING GEOTEXTILE, 6" Ø DRAINAGE PIPE, WELDED WIRE FORM, AND SELECT MATERIAL, SEE ROADWAY PLANS.

GEOTEXTILE (TYPE 1 OR TYPE 5) SHALL BE IN ACCORDANCE WITH THE STANDARD SPECIFICATIONS SECTION 1056.

SELECT MATERIAL BACKFILL (CLASS V OR CLASS VI) SHALL BE IN ACCORDANCE WITH STANDARD SPECIFICATIONS SECTION 1016.

SELECT MATERIAL BACKFILL IS TO BE CONTINUOUS ALONG FILL FACE OF BACKWALL FROM OUTSIDE EDGE TO OUTSIDE EDGE OF APPROACH SLAB.

FOR THE 6" Ø DRAINAGE PIPE OUTLET(S), SEE ROADWAY STANDARD DRAWINGS.

AREA BETWEEN THE WINGWALL AND APPROACH SLAB SHALL BE GRADED TO DRAIN THE WATER AWAY FROM THE FILL FACE OF THE BRIDGE AND SHALL BE PAVED. SEE ROADWAY PLANS.

THE JOINT OPENING AT THE APPROACH SLAB/DECK INTERFACE SHALL BE SAWED NO MORE THAN 12 HOURS AFTER THE APPROACH SLAB IS CAST. THE JOINT SHALL BE CLEANED OF ALL DEBRIS BEFORE THE SEALANT IS APPLIED. THE JOINT SEALER MATERIAL SHALL CONFORM TO THE REQUIREMENTS OF SECTION 1028-3 OF THE STANDARD SPECIFICATIONS.

PROJECT NO. Y-4810K
CABARRUS COUNTY
 STATION: 31+94.08 -L-

SHEET 2 OF 3

STATE OF NORTH CAROLINA
 DEPARTMENT OF TRANSPORTATION
 RALEIGH

BRIDGE APPROACH SLAB
 FOR INTEGRAL
 END BENT

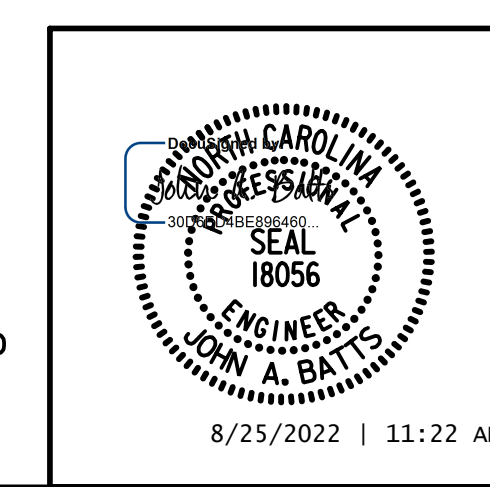

DRAWN BY: S.D. COOPER	DATE: 2-19
CHECKED BY: J. A. BATTS	DATE: 2-19
DESIGN ENGINEER OF RECORD: J. A. BATTS	DATE: 2-19

REVISIONS						SHEET NO.
NO.	BY:	DATE:	NO.	BY:	DATE:	S-52
1			3			TOTAL SHEETS
2			4			53

LICENSURE NO. C-4434

8/25/2022 | 11:22 AM

**DOCUMENT NOT CONSIDERED FINAL
 UNLESS ALL SIGNATURES COMPLETED**