

8/25/2022 2:05:06 PM P:\Rail\Projects\2015\Y-4810K (NCDOT Rail)\Div\Structures\Drawings\Final\Y-4810K_SMU_BM.dgn

SUPERSTRUCTURE REINFORCING STEEL LENGTHS ARE BASED ON THE FOLLOWING MINIMUM SPLICE LENGTHS					
BAR SIZE	SUPERSTRUCTURE EXCEPT APPROACH SLABS, PARAPET, AND BARRIER RAIL		APPROACH SLABS		PARAPET AND BARRIER RAIL
	EPOXY COATED	UNCOATED	EPOXY COATED	UNCOATED	
#4	2'-0"	1'-9"	2'-0"	1'-9"	2'-9"
#5	2'-6"	2'-2"	2'-6"	2'-2"	3'-5"
#6	3'-0"	2'-7"	3'-10"	2'-7"	4'-4"
#7	5'-3"	3'-6"			
#8	6'-10"	4'-7"			

GROOVING BRIDGE FLOORS		
APPROACH SLABS	1,596	SF
BRIDGE DECK	15,698	SF
TOTAL	17,294	SF

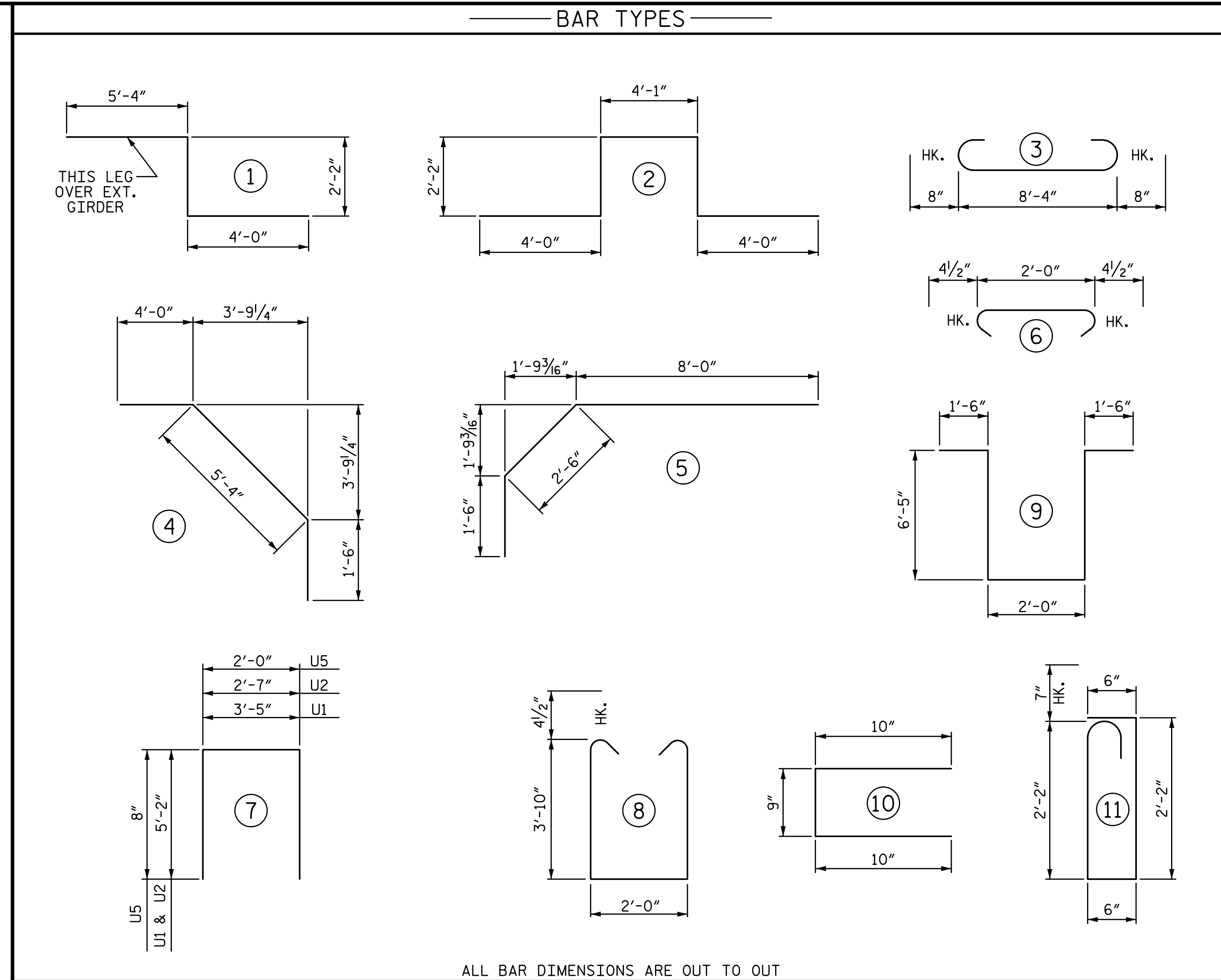

BILL OF MATERIAL					
BAR	NO.	SIZE	TYPE	LENGTH	WEIGHT
*A1	762	#5	STR	43'-9"	34771
A2	762	#5	STR	43'-9"	34771
*B1	176	#6	STR	22'-10"	6036
*B2	120	#4	STR	28'-6"	2285
*B3	60	#5	STR	24'-3"	1518
*B4	60	#5	STR	60'-0"	3755
*B5	116	#6	STR	48'-0"	8363
*B6	180	#4	STR	29'-6"	3547
B7	520	#5	STR	49'-6"	26847
*B8	50	#4	STR	24'-9"	827
*B9	50	#4	STR	27'-2"	907
*G1	2	#5	STR	43'-9"	91
*G2	476	#4	STR	5'-0"	1590
K1	24	#4	STR	23'-3"	373
K2	8	#4	STR	6'-9"	36
K3	40	#4	STR	8'-4"	223
K4	4	#4	STR	2'-1"	6
K5	20	#4	STR	2'-11"	39
K6	16	#4	STR	5'-7"	60
K7	80	#4	STR	8'-4"	445
K8	16	#4	STR	5'-4"	57
K9	28	#4	STR	20'-2"	377
*K10	8	#8	1	11'-6"	246
*K11	12	#8	2	16'-5"	526
K12	16	#6	STR	5'-4"	128
K13	16	#6	3	9'-8"	232
*S1	56	#4	5	12'-0"	449
*S2	56	#4	4	10'-10"	405
S3	352	#4	6	2'-9"	647
*S4	48	#4	10	2'-5"	77
*S5	48	#5	11	5'-11"	296
U1	60	#4	7	13'-9"	551
U2	4	#4	7	12'-11"	35
U3	16	#4	8	10'-5"	111
U4	48	#4	9	17'-10"	572
*U5	140	#4	7	3'-4"	312

* INDICATES EPOXY COATED REINFORCING STEEL

— SUPERSTRUCTURE BILL OF MATERIAL —			
	CLASS AA CONCRETE	REINFORCING STEEL	EPOXY COATED REINFORCING STEEL
	CY	LB	LB
POUR 1	138.4		
POUR 2	214.5		
POUR 3	138.4		
POUR 4	214.5		
POUR 5	89.4		
SIDEWALK	58.3		
TOTALS**	853.5	65,510	66,001

** QUANTITIES FOR PARAPETS AND END POSTS ARE NOT INCLUDED

PROJECT NO. Y-4810K
CABARRUS COUNTY
 STATION: 31+94.08 -L-

SHEET 2 OF 2

STATE OF NORTH CAROLINA
 DEPARTMENT OF TRANSPORTATION
 RALEIGH
 SUPERSTRUCTURE

BILL OF MATERIAL

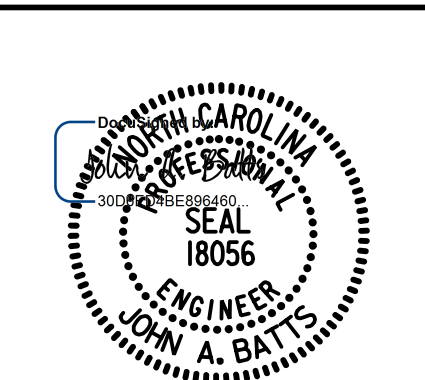

8/25/2022 | 11:22 AM

LICENSURE NO. C-4434

DOCUMENT NOT CONSIDERED FINAL UNLESS ALL SIGNATURES COMPLETED

REVISIONS				SHEET NO.
NO.	BY:	DATE:	NO.	DATE:
1			3	
2			4	

TOTAL SHEETS: 53

DRAWN BY: J. R. SEALEY DATE: 2-19
 CHECKED BY: J. A. BATTS DATE: 2-19
 DESIGN ENGINEER OF RECORD: J. A. BATTS DATE: 2-19