

p:\gfn\pw\benfley.com\gfn\pw-01\Documents\Projects\67945\5-Working\Task 005 - I-5889B Rehab\Structures\CAD\2.0 100% Plans\404_105_I-5889B_SMU_GD01_001_100347.rvt/2/21/2022 11:29:50 PM pdf_color_gfclt_FS.plt I-5889B.TBI

NOTE:
 GENERAL DRAWING INFORMATION IS TAKEN FROM THE ORIGINAL PLANS AND THE ROUTINE INSPECTION REPORT DATED 10/17/2019.
 BRIDGE ORIENTATION CONFORMS TO THE EXISTING BRIDGE PLANS AND ROUTINE INSPECTION REPORT.

- SCOPE OF WORK**
- REMOVE ASPHALT WEARING SURFACE AND PARTIALLY REMOVE TOP OF BRIDGE DECK CONCRETE BY FINE MILLING AND HYDRO-DEMOLITION.
 - OVERLAY PREPARED TOP OF BRIDGE DECK WITH VERY EARLY STRENGTH LATEX MODIFIED CONCRETE (LMC-VES).
 - REMOVE EXISTING JOINT MATERIAL AND INSTALL FOAM JOINTS.
 - GROOVE LMC-VES BRIDGE DECK.
 - REMOVE AND REPLACE EXISTING TUBULAR TRIPLE CORRUGATED STEEL BEAM BRIDGE RAIL.
 - REMOVE AND REPLACE EXISTING STEEL BEAM GUARDRAIL AND GUARDRAIL ANCHOR UNITS.
 - MILL AND REPAVE ASPHALT APPROACH ROADWAYS.
 - REMOVE DEBRIS FROM TOP OF EXISTING BENT CAPS AND APPLY EPOXY COATING.
 - EPOXY RESIN INJECTION OF CONCRETE CRACKS.
 - REMOVE UNSOUND CONCRETE AND PROPERLY PREPARE EXISTING END BENT AND BENT AREAS FOR SHOTCRETE AND CONCRETE REPAIRS.

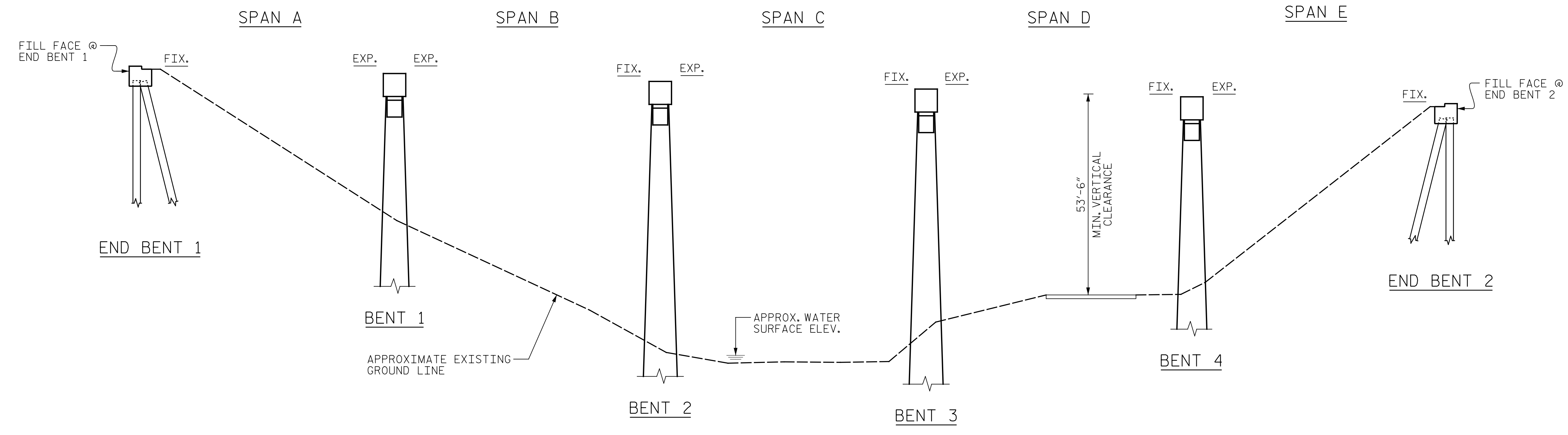

SECTION ALONG Q BRIDGE
 (SECTION AT BENTS AND END BENTS ARE AT RIGHT ANGLES)

I HEREBY CERTIFY THAT THIS STRUCTURE WAS REHABILITATED ACCORDING TO THESE PLANS OR AS NOTED HEREIN.

RESIDENT ENGINEER _____ DATE _____

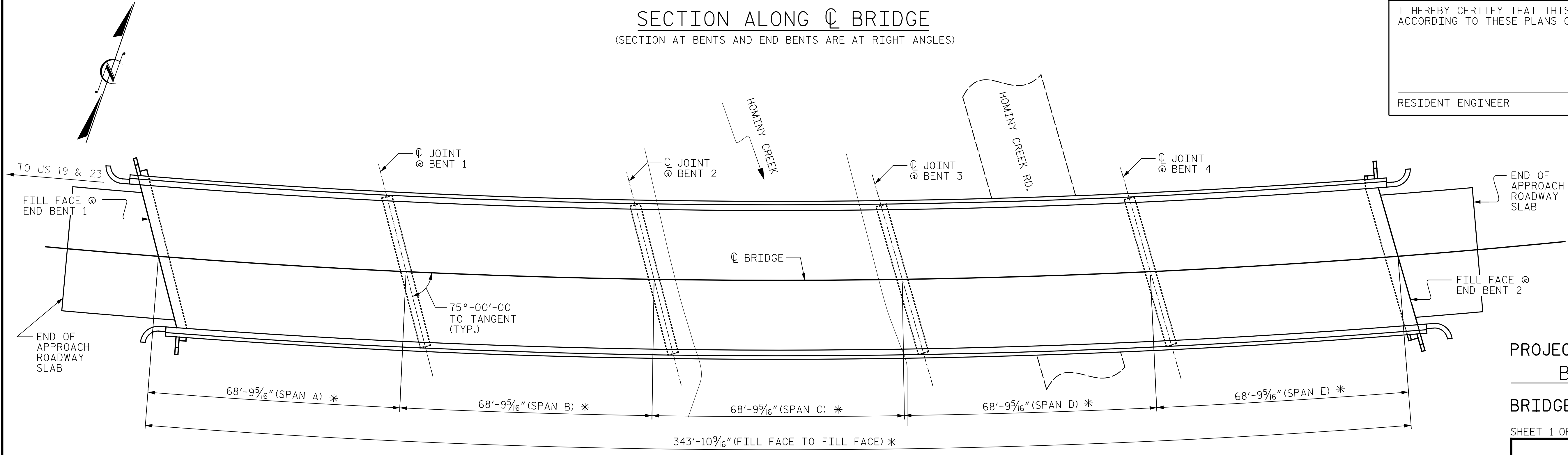

PLAN
 (PILES NOT SHOWN FOR CLARITY)

* DIMENSIONS MEASURED ALONG ARC

PROJECT NO. I-5889B
BUNCOMBE COUNTY
 BRIDGE NO. 100347

SHEET 1 OF 2

STATE OF NORTH CAROLINA
 DEPARTMENT OF TRANSPORTATION
 RALEIGH

GENERAL DRAWING
 FOR BRIDGE ON I-40 WBL OVER
 SR 3620 (HOMINY CREEK ROAD)
 AND HOMINY CREEK

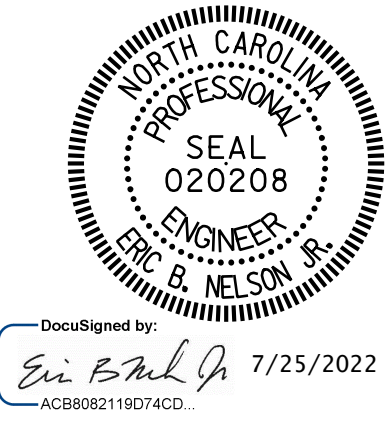

DocuSigned by:
 Eric B. Nelson
 7/25/2022



DOCUMENT NOT CONSIDERED FINAL UNLESS ALL SIGNATURES COMPLETED

DRAWN BY: M. LEE/J. MYA DATE: 6/2022
 CHECKED BY: J. YANNACCONE DATE: 6/2022

REVISIONS						SHEET NO.
NO.	BY:	DATE:	NO.	BY:	DATE:	
1			3			S4-1
2			4			TOTAL SHEETS 133