

p:\gfn\pw\ben\paw\Documents\Projects\67945\5-WorKing\Task 005 - I-5889B Rehab\Structures\CAD\2.0 100% Plans\402_035_I-5889B_SMU_GD01_001_100339
 7/21/2022 3:45:26 PM pdf_color_gfclt_FS.plt I-5889B.tbl

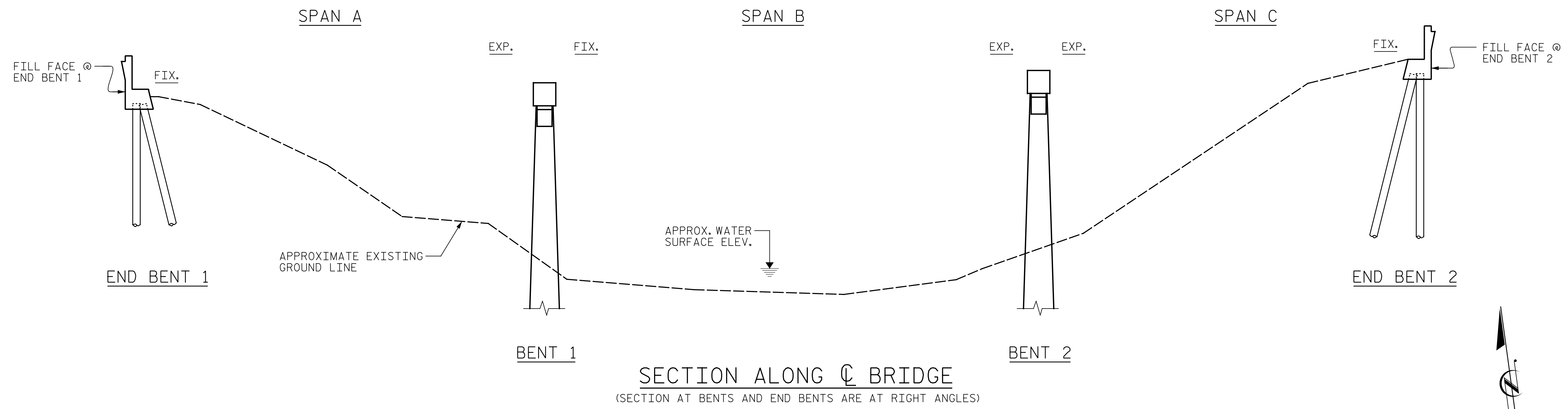

NOTE:
 GENERAL DRAWING INFORMATION IS TAKEN FROM THE ORIGINAL PLANS AND THE ROUTINE INSPECTION REPORT DATED 10/05/2021.
 BRIDGE ORIENTATION CONFORMS TO THE EXISTING BRIDGE PLANS AND ROUTINE INSPECTION REPORT.
SCOPE OF WORK
 - REMOVE ASPHALT WEARING SURFACE AND PARTIALLY REMOVE TOP OF BRIDGE DECK CONCRETE BY FINE MILLING AND HYDRO-DEMOLITION.
 - OVERLAY PREPARED TOP OF BRIDGE DECK WITH VERY EARLY STRENGTH LATEX MODIFIED CONCRETE (LMC-VES).
 - REMOVE EXISTING JOINT MATERIAL AND INSTALL FOAM JOINTS.
 - GROOVE LMC-VES BRIDGE DECK.
 - REMOVE AND REPLACE EXISTING TUBULAR TRIPLE CORRUGATED STEEL BEAM BRIDGE RAIL.
 - REMOVE AND REPLACE EXISTING STEEL BEAM GUARDRAIL AND GUARDRAIL ANCHOR UNITS.
 - MILL AND REPAVE ASPHALT APPROACH ROADWAYS.
 - REMOVE DEBRIS FROM TOP OF EXISTING END BENT AND BENT CAPS AND APPLY EPOXY COATING.
 - EPOXY RESIN INJECTION OF CONCRETE CRACKS.
 - REMOVE UNSOUND CONCRETE AND PROPERLY PREPARE EXISTING END BENT AND BENT AREAS FOR SHOTCRETE AND CONCRETE REPAIRS.

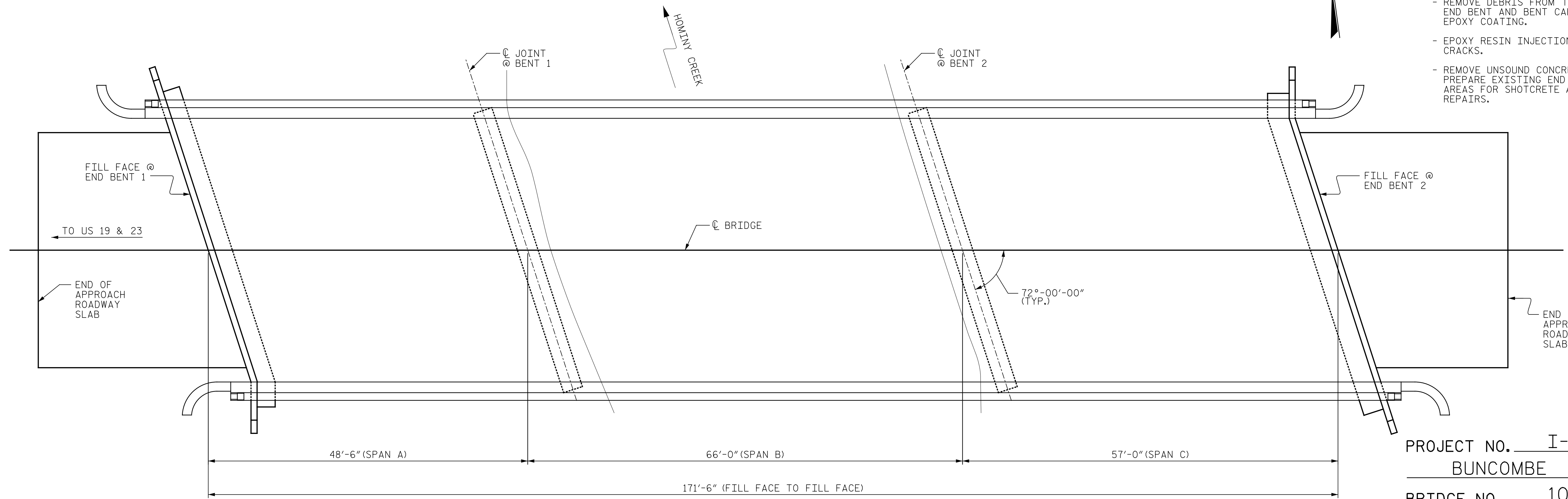

PLAN
 (PILES NOT SHOWN FOR CLARITY)

PROJECT NO. I-5889B
BUNCOMBE COUNTY
 BRIDGE NO. 100339

SHEET 1 OF 2

STATE OF NORTH CAROLINA
 DEPARTMENT OF TRANSPORTATION
 RALEIGH

GENERAL DRAWING
 FOR BRIDGE ON I-40 WBL
 OVER HOMINY CREEK

I HEREBY CERTIFY THAT THIS STRUCTURE WAS REHABILITATED ACCORDING TO THESE PLANS OR AS NOTED HEREIN.

RESIDENT ENGINEER _____ DATE _____



DocuSigned by:
 Eric B. Nelson 7/25/2022



DOCUMENT NOT CONSIDERED FINAL UNLESS ALL SIGNATURES COMPLETED

DRAWN BY : J. MYA DATE : 6/2022
 CHECKED BY : J. YANACCONO DATE : 6/2022

REVISIONS						SHEET NO.
NO.	BY:	DATE:	NO.	BY:	DATE:	
1			3			S2-1
2			4			TOTAL SHEETS 133