

**This electronic collection of documents is provided
for the convenience of the user
and is Not a Certified Document –**

**The documents contained herein were originally issued
and sealed by the individuals whose names and license
numbers appear on each page, on the dates appearing
with their signature on that page.**

**This file or an individual page
shall not be considered a certified document.**

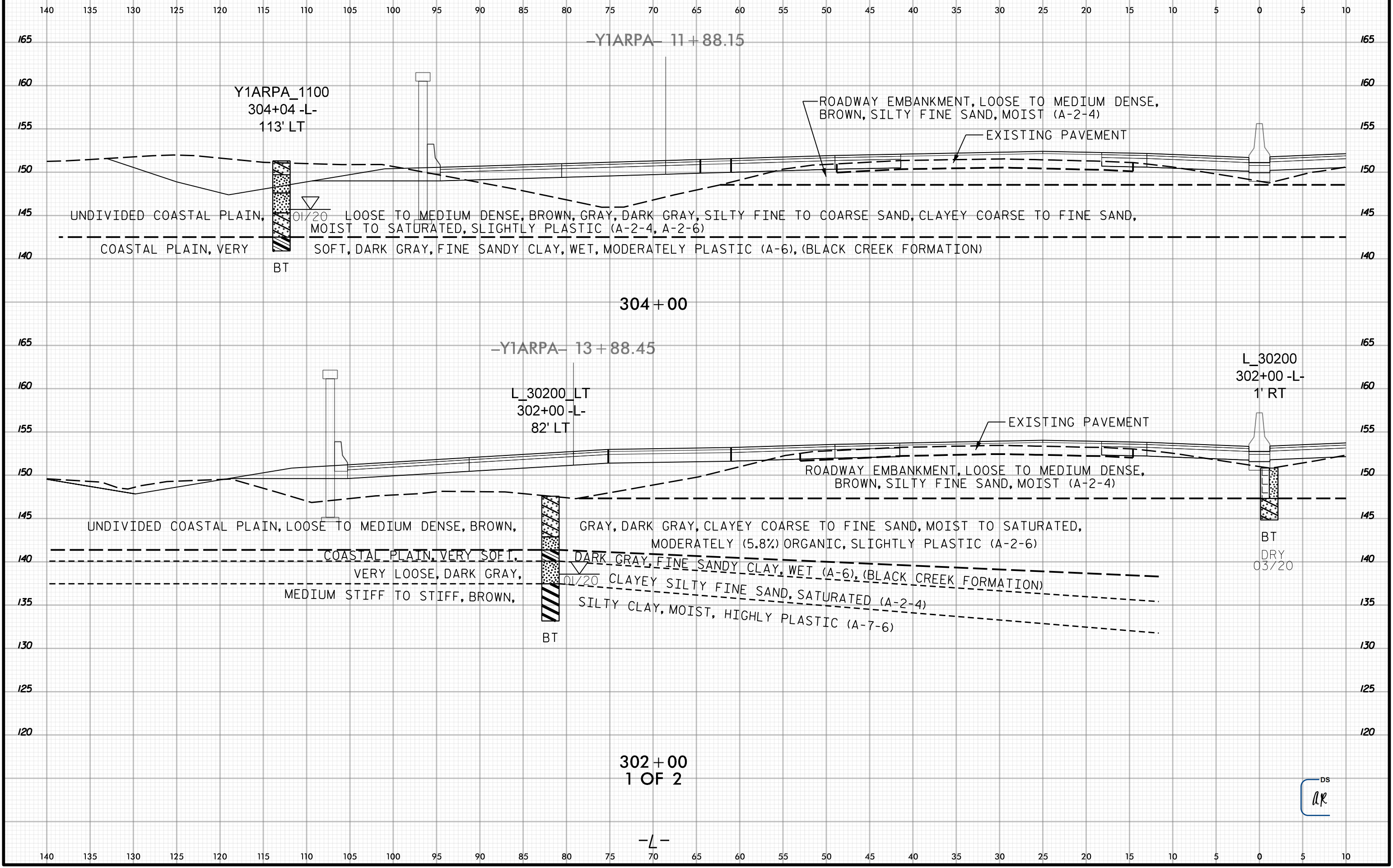
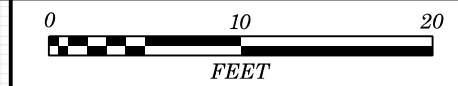

-Y1ARPA- 11 + 88.15

Y1ARPA_1100
304+04 -L-
113' LT

ROADWAY EMBANKMENT, LOOSE TO MEDIUM DENSE,
BROWN, SILTY FINE SAND, MOIST (A-2-4)
EXISTING PAVEMENT

UNDIVIDED COASTAL PLAIN, LOOSE TO MEDIUM DENSE, BROWN, GRAY, DARK GRAY, SILTY FINE TO COARSE SAND, CLAYEY COARSE TO FINE SAND,
MOIST TO SATURATED, SLIGHTLY PLASTIC (A-2-4, A-2-6)
COASTAL PLAIN, VERY SOFT, DARK GRAY, FINE SANDY CLAY, WET, MODERATELY PLASTIC (A-6), (BLACK CREEK FORMATION)

BT

304 + 00

-Y1ARPA- 13 + 88.45

L_30200_LT
302+00 -L-
82' LT

EXISTING PAVEMENT

ROADWAY EMBANKMENT, LOOSE TO MEDIUM DENSE,
BROWN, SILTY FINE SAND, MOIST (A-2-4)

UNDIVIDED COASTAL PLAIN, LOOSE TO MEDIUM DENSE, BROWN,
COASTAL PLAIN, VERY SOFT,
VERY LOOSE, DARK GRAY,
MEDIUM STIFF TO STIFF, BROWN,
GRAY, DARK GRAY, CLAYEY COARSE TO FINE SAND, MOIST TO SATURATED,
MODERATELY (5.8%) ORGANIC, SLIGHTLY PLASTIC (A-2-6)
DARK GRAY, FINE SANDY CLAY, WET (A-6), (BLACK CREEK FORMATION)
CLAYEY SILTY FINE SAND, SATURATED (A-2-4)
SILTY CLAY, MOIST, HIGHLY PLASTIC (A-7-6)

BT

L_30200
302+00 -L-
1' RT

BT
DRY
03/20

302 + 00
1 OF 2

DS
AR

-L-

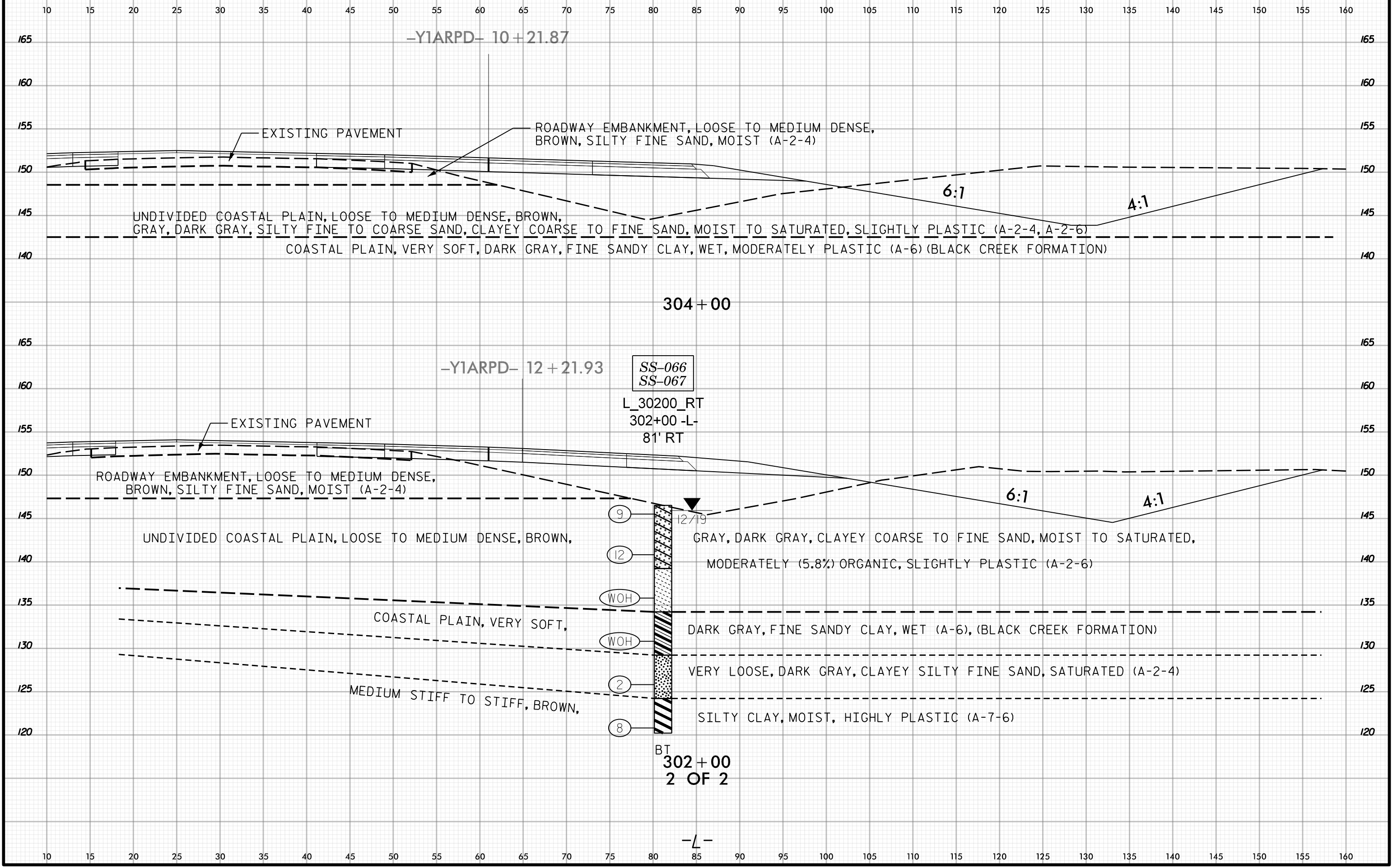
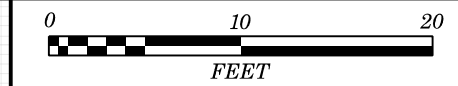

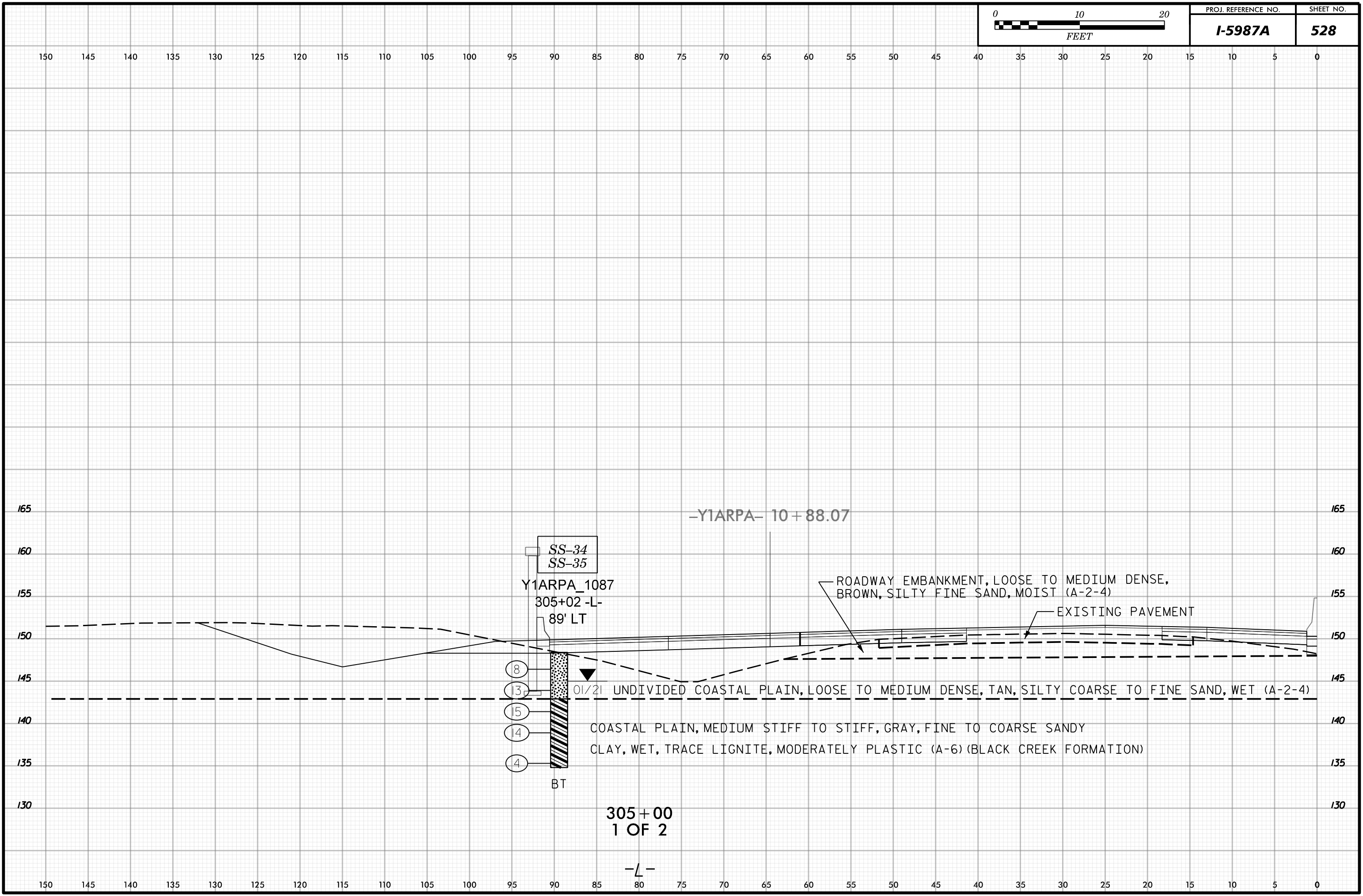

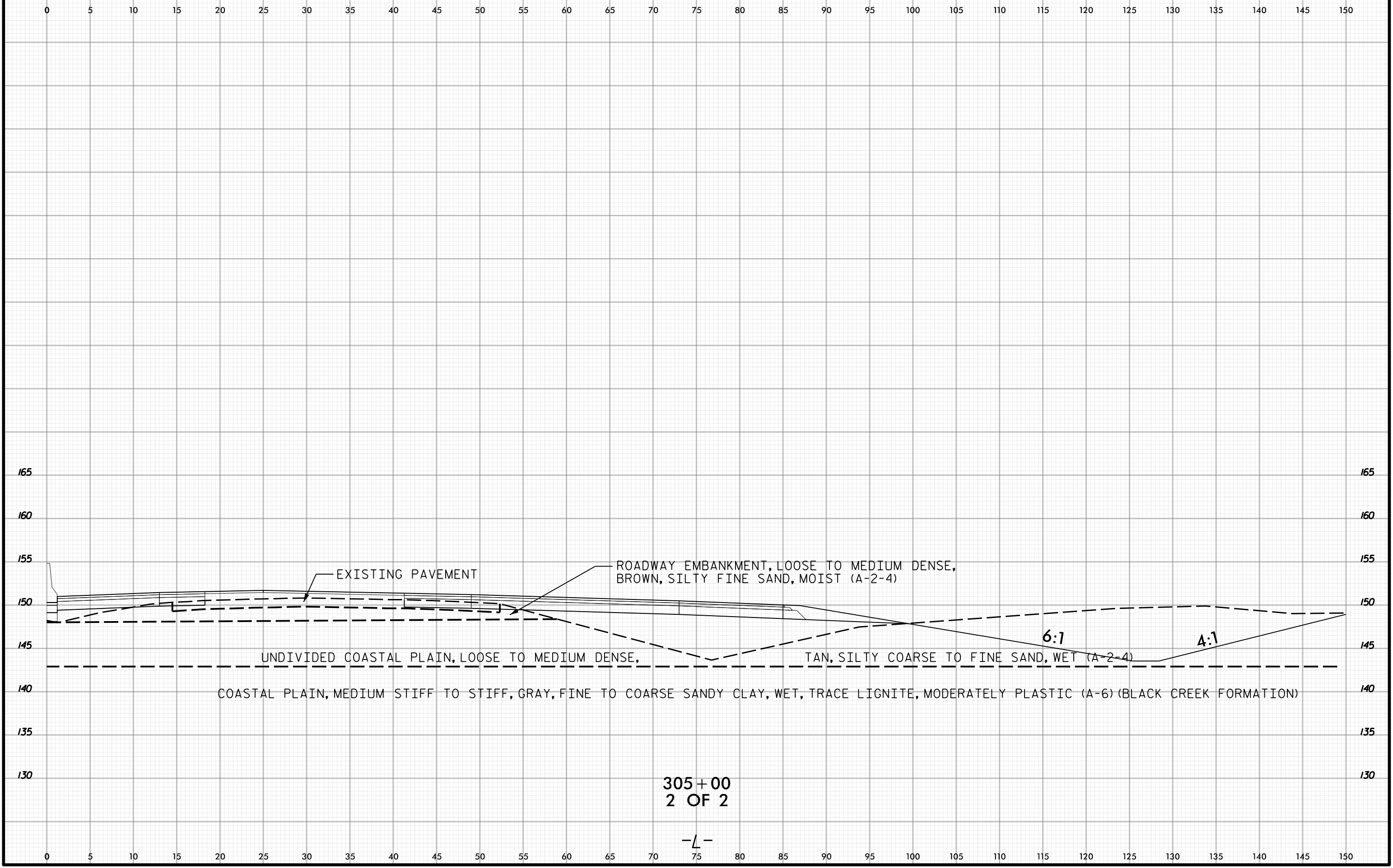

305+00
2 OF 2

-L-

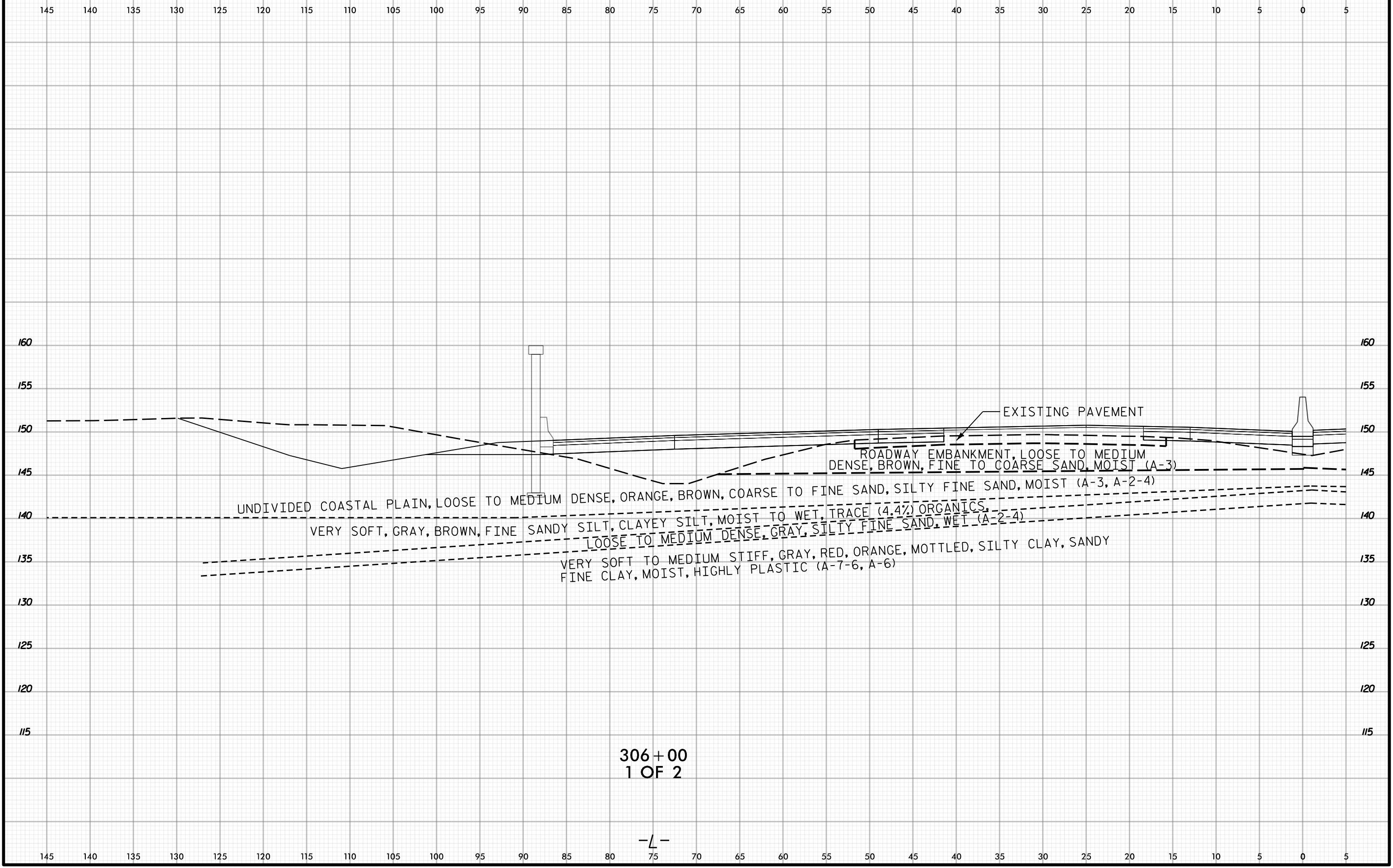



5 0 5 10 15 20 25 30 35 40 45 50 55 60 65 70 75 80 85 90 95 100 105 110 115 120 125 130 135 140 145

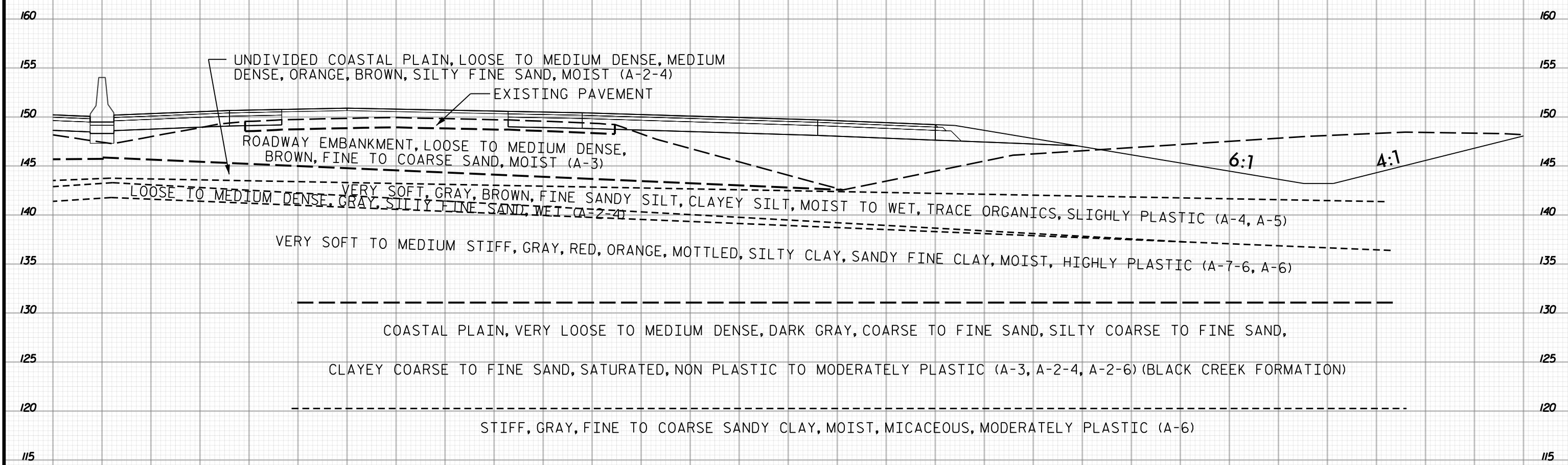

306+00
2 OF 2

5 0 5 10 15 20 25 30 35 40 45 50 55 60 65 70 75 80 85 90 95 100 105 110 115 120 125 130 135 140 145

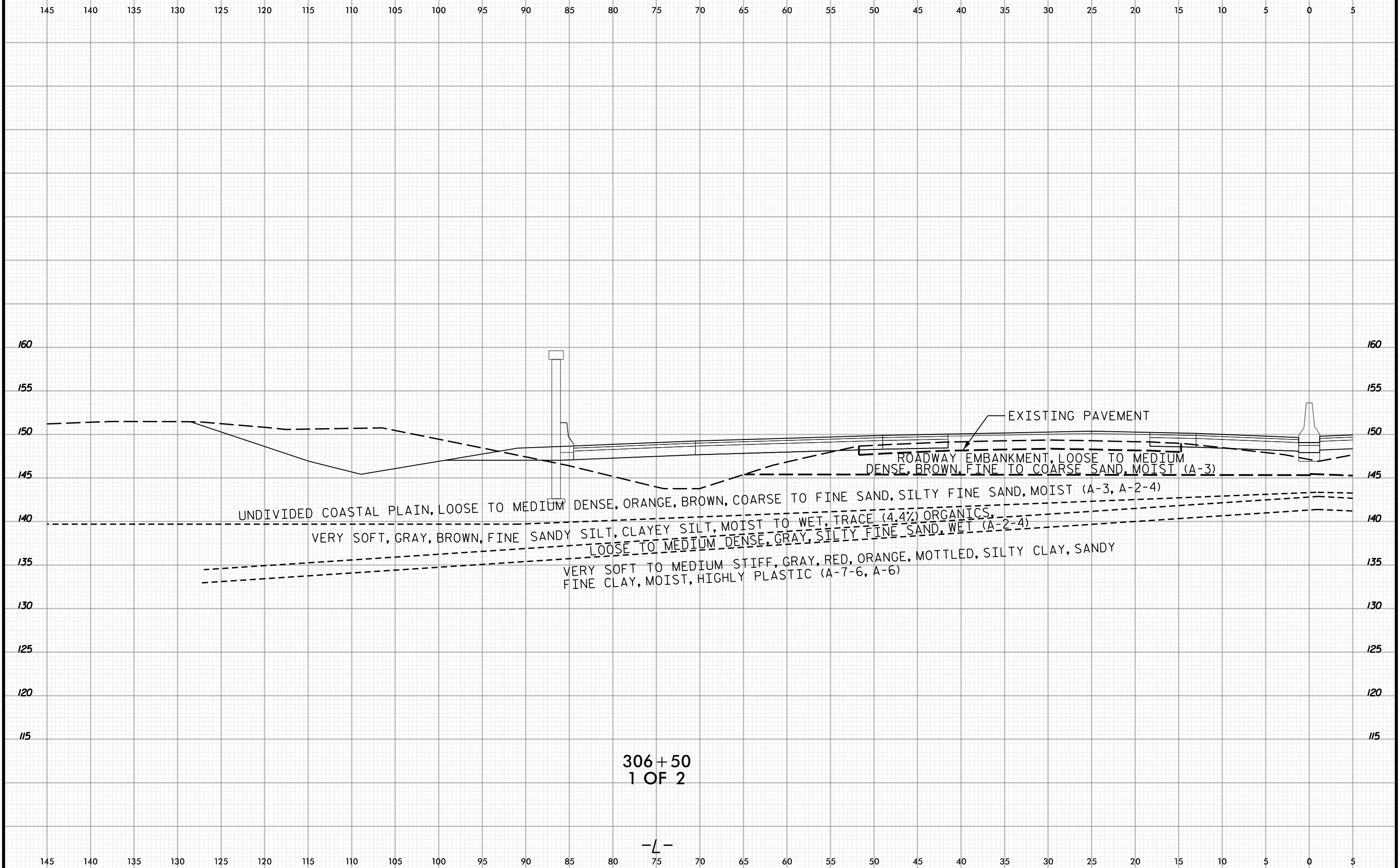

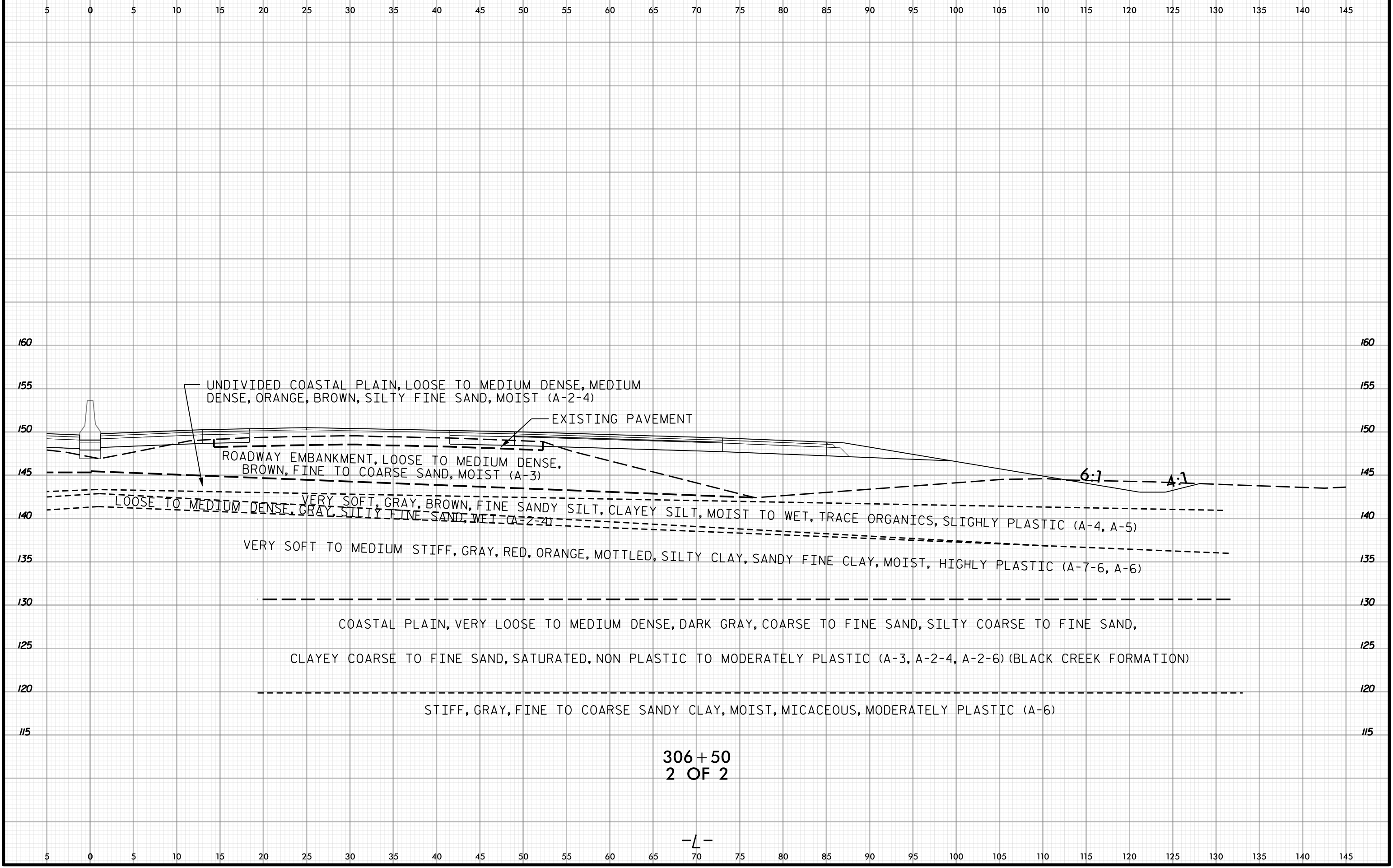

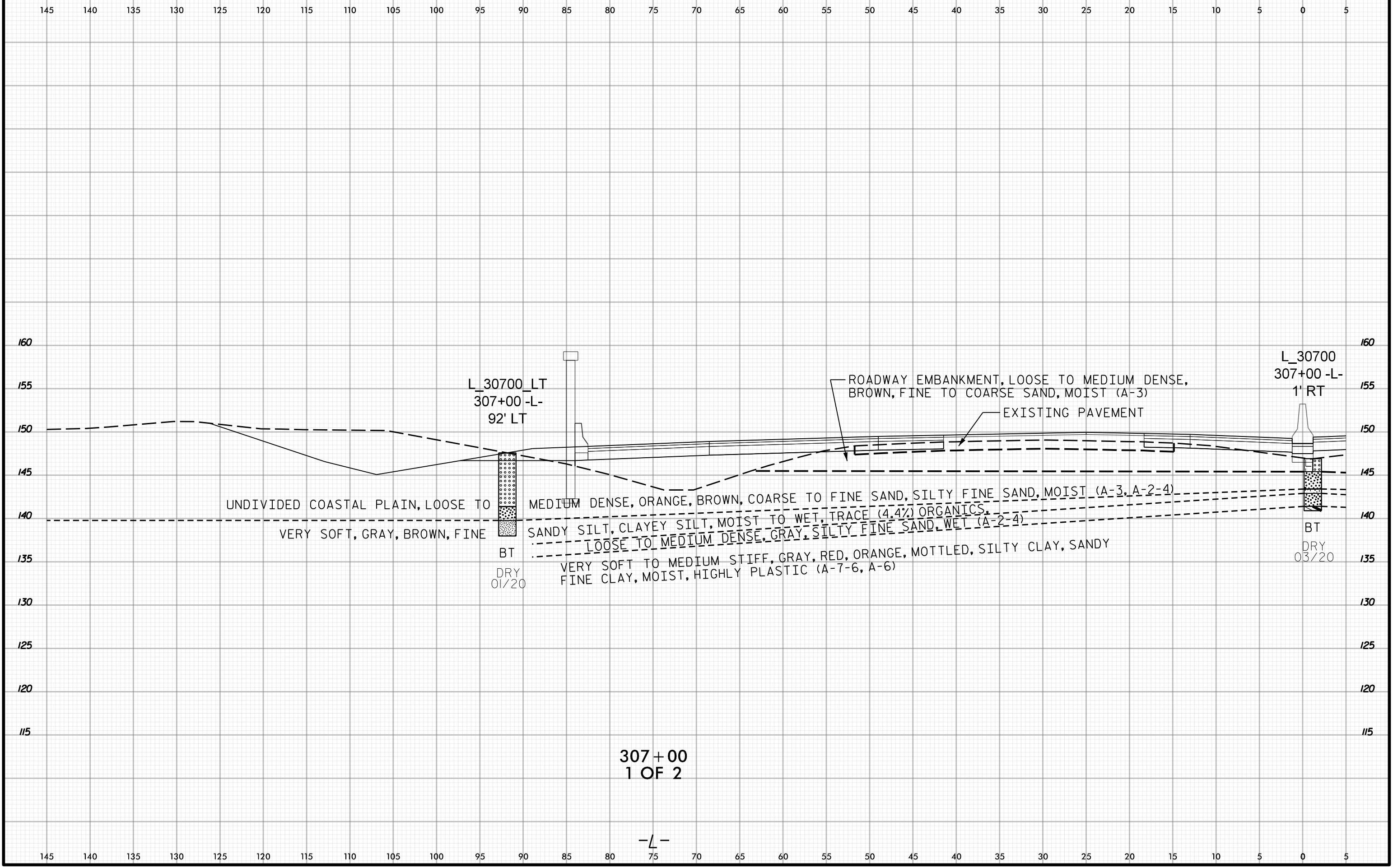



5 0 5 10 15 20 25 30 35 40 45 50 55 60 65 70 75 80 85 90 95 100 105 110 115 120 125 130 135 140 145

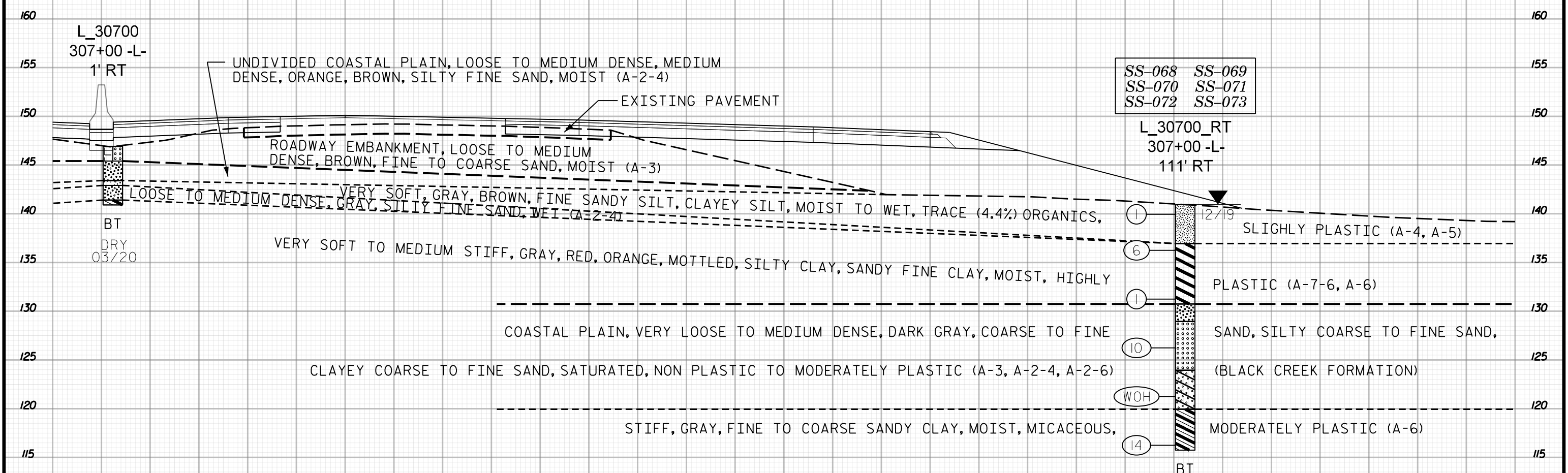

307+00
2 OF 2

5 0 5 10 15 20 25 30 35 40 45 50 55 60 65 70 75 80 85 90 95 100 105 110 115 120 125 130 135 140 145

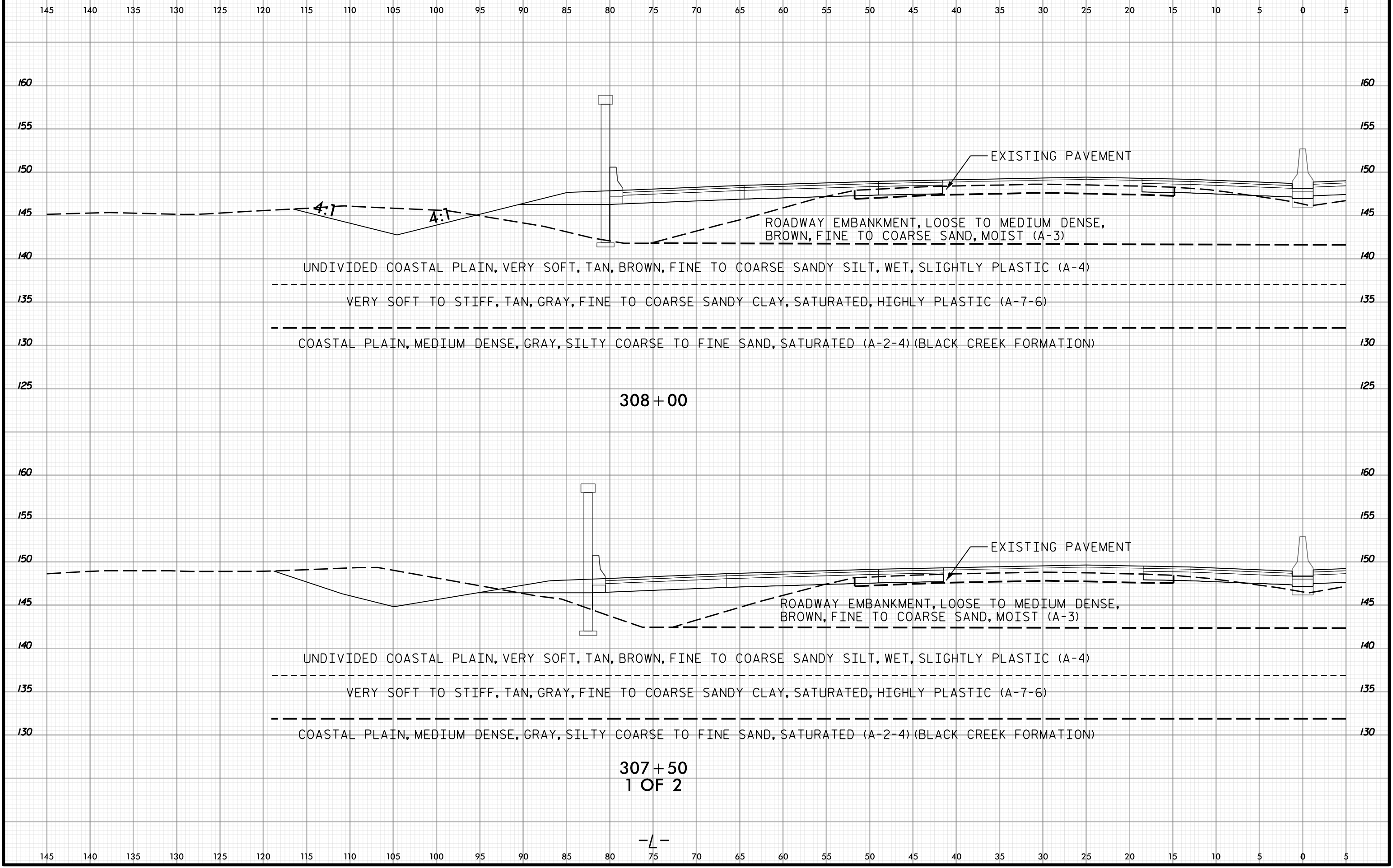
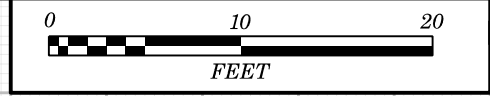

308+00

307+50
1 OF 2

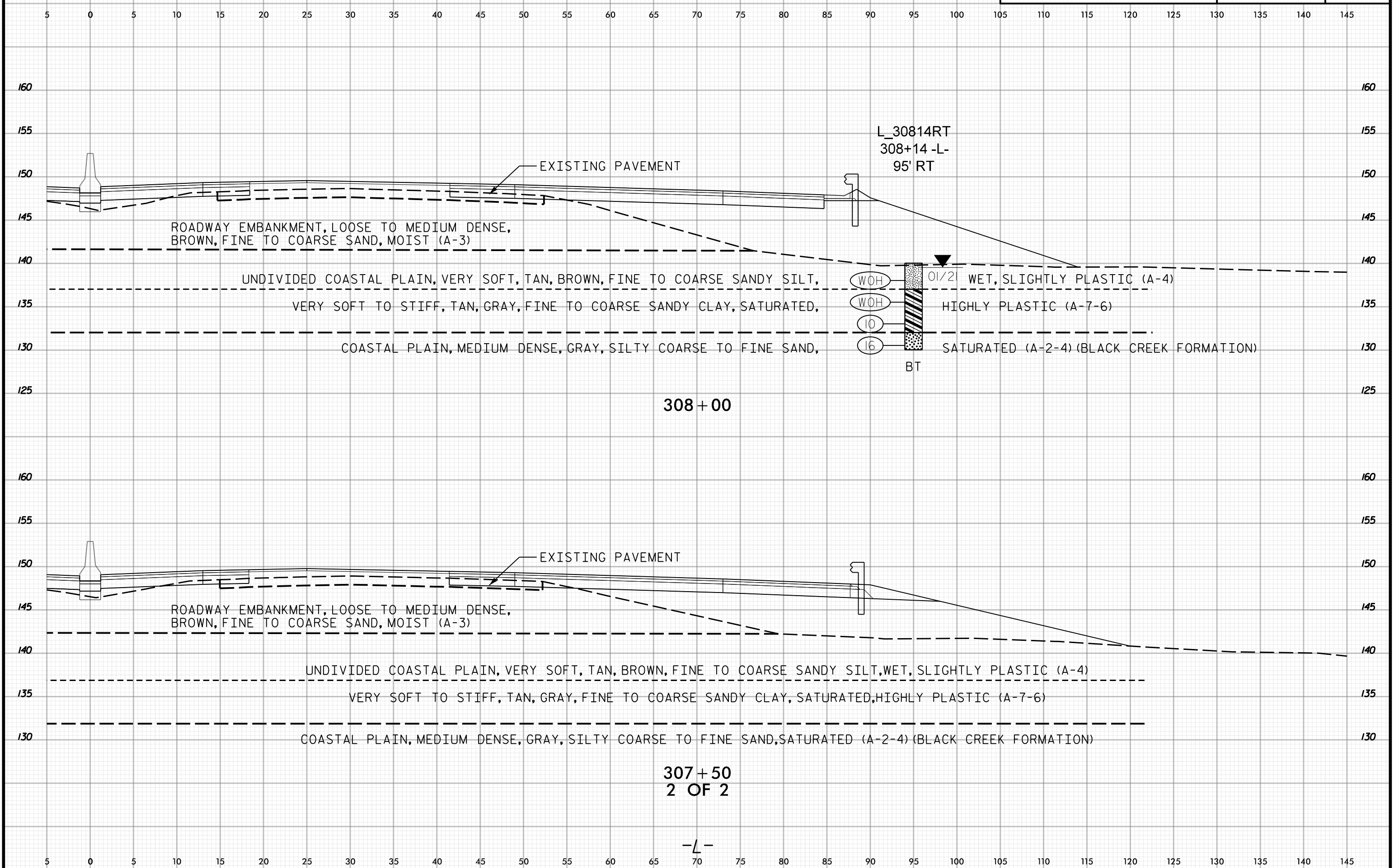
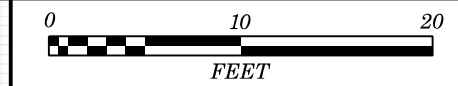

L_30814RT
308+14 -L-
95' RT

308+00

307+50
2 OF 2

-L-



145 140 135 130 125 120 115 110 105 100 95 90 85 80 75 70 65 60 55 50 45 40 35 30 25 20 15 10 5 0 5

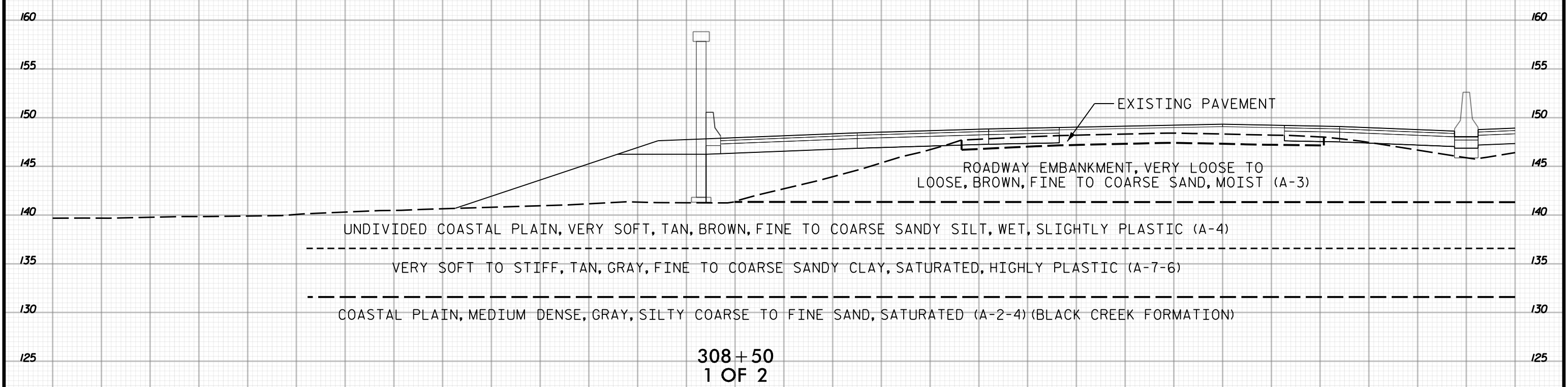
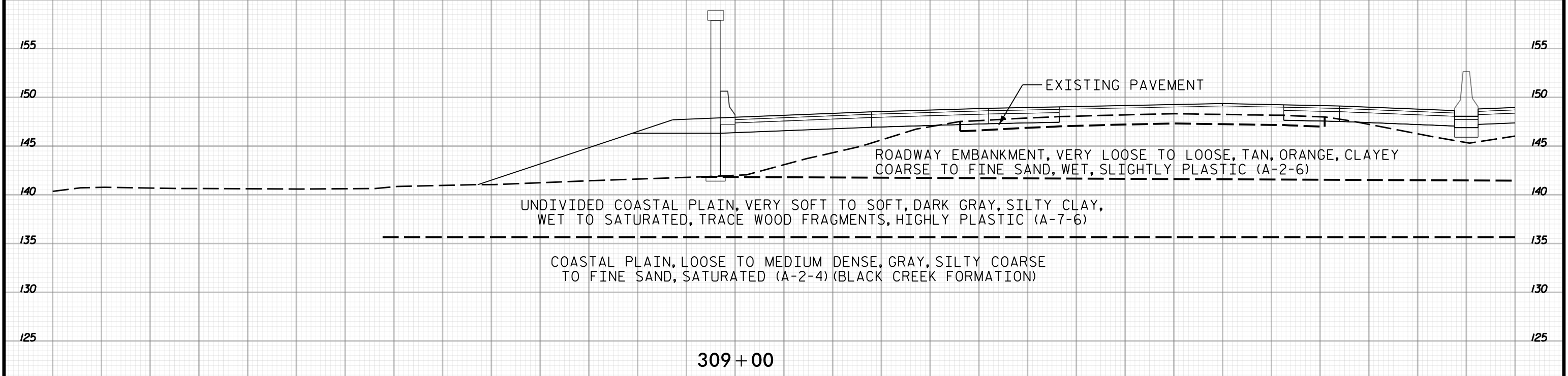

145 140 135 130 125 120 115 110 105 100 95 90 85 80 75 70 65 60 55 50 45 40 35 30 25 20 15 10 5 0 5

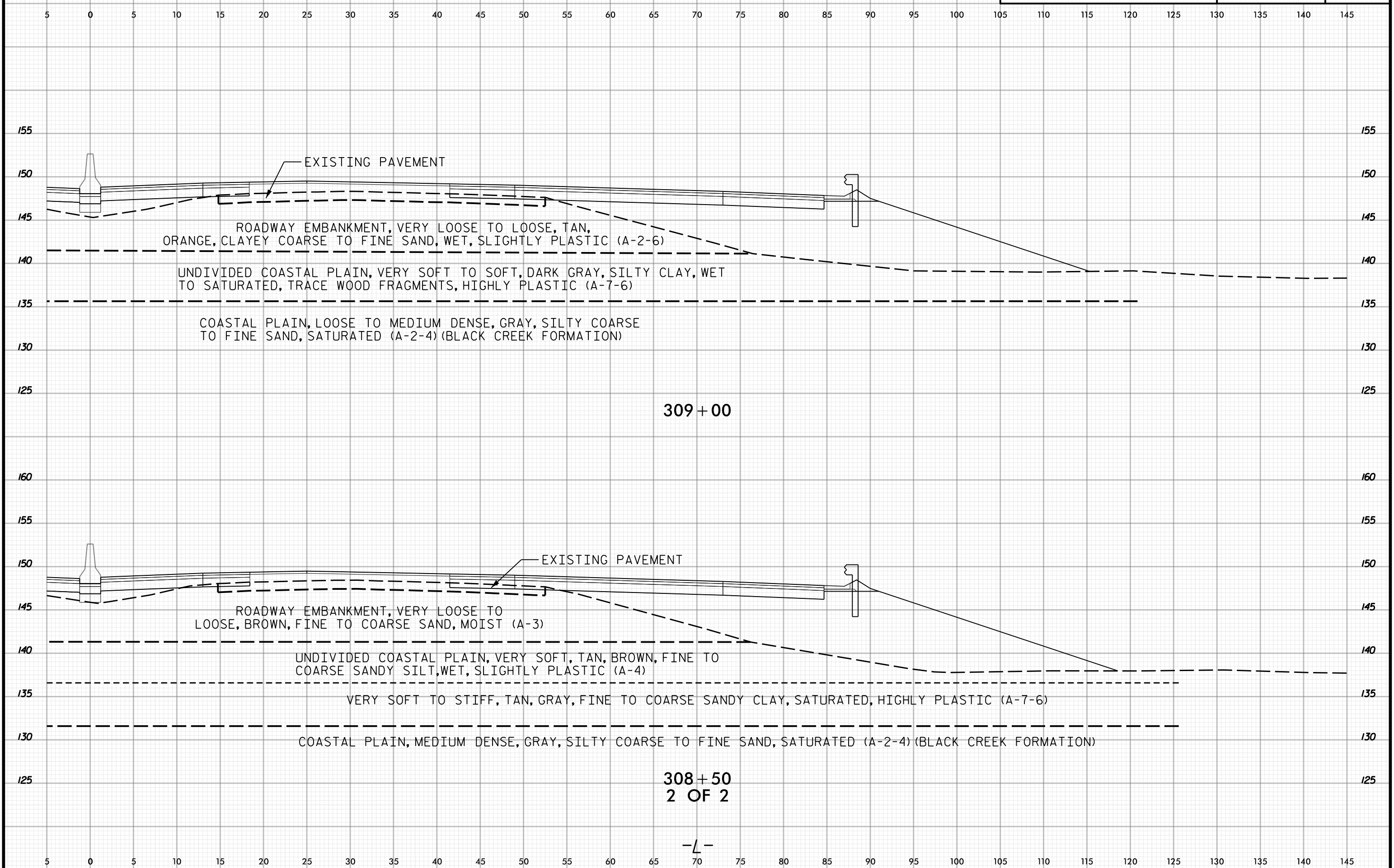

EXISTING PAVEMENT

ROADWAY EMBANKMENT, VERY LOOSE TO LOOSE, TAN, ORANGE, CLAYEY COARSE TO FINE SAND, WET, SLIGHTLY PLASTIC (A-2-6)

UNDIVIDED COASTAL PLAIN, VERY SOFT TO SOFT, DARK GRAY, SILTY CLAY, WET TO SATURATED, TRACE WOOD FRAGMENTS, HIGHLY PLASTIC (A-7-6)

COASTAL PLAIN, LOOSE TO MEDIUM DENSE, GRAY, SILTY COARSE TO FINE SAND, SATURATED (A-2-4) (BLACK CREEK FORMATION)

309+00

EXISTING PAVEMENT

ROADWAY EMBANKMENT, VERY LOOSE TO LOOSE, BROWN, FINE TO COARSE SAND, MOIST (A-3)

UNDIVIDED COASTAL PLAIN, VERY SOFT, TAN, BROWN, FINE TO COARSE SANDY SILT, WET, SLIGHTLY PLASTIC (A-4)

VERY SOFT TO STIFF, TAN, GRAY, FINE TO COARSE SANDY CLAY, SATURATED, HIGHLY PLASTIC (A-7-6)

COASTAL PLAIN, MEDIUM DENSE, GRAY, SILTY COARSE TO FINE SAND, SATURATED (A-2-4) (BLACK CREEK FORMATION)

308+50
2 OF 2

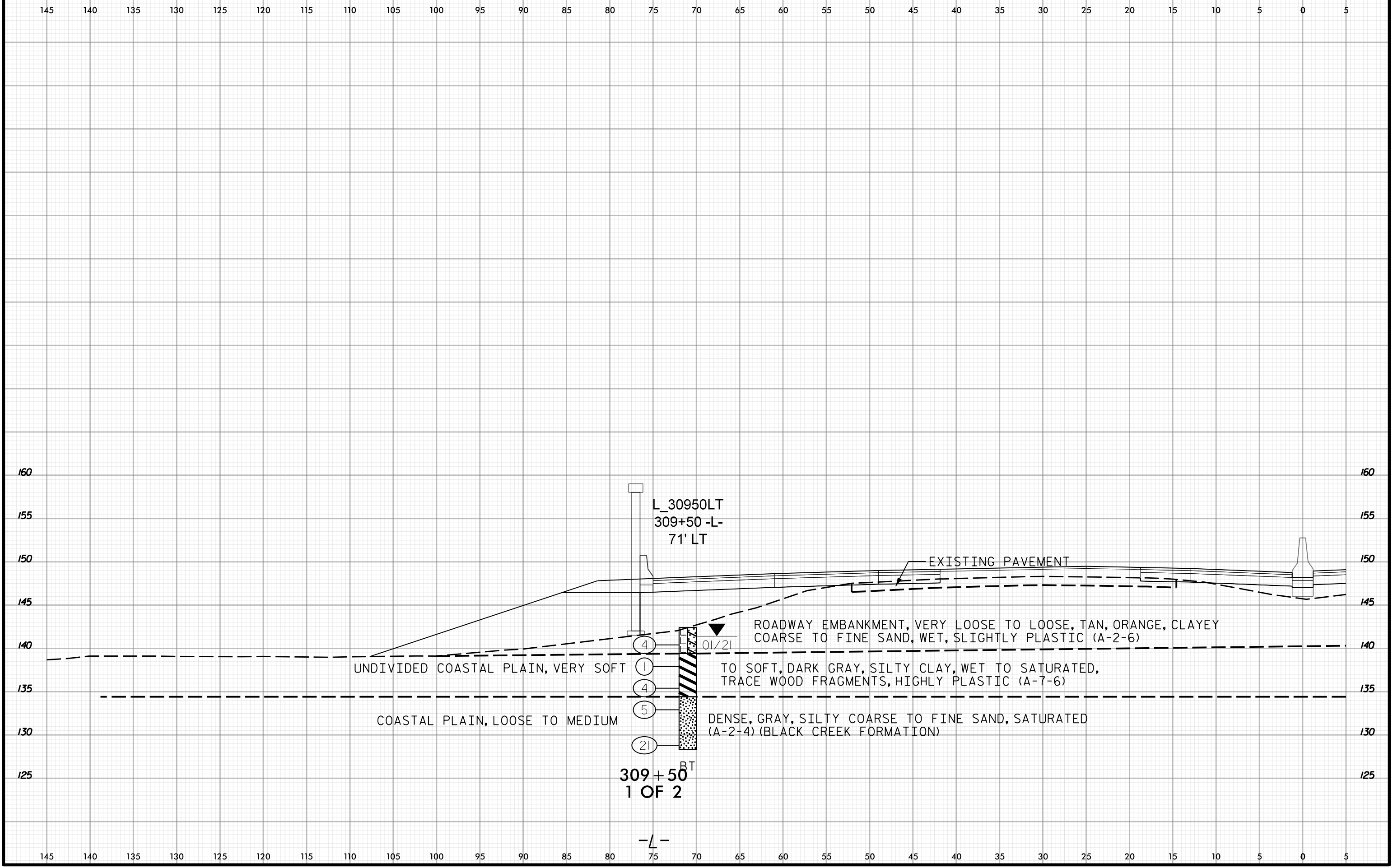
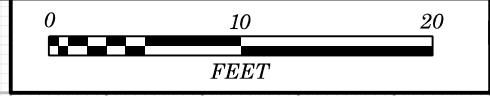

L_30950LT
309+50 -L-
71' LT

EXISTING PAVEMENT

ROADWAY EMBANKMENT, VERY LOOSE TO LOOSE, TAN, ORANGE, CLAYEY
COARSE TO FINE SAND, WET, SLIGHTLY PLASTIC (A-2-6)

UNDIVIDED COASTAL PLAIN, VERY SOFT

TO SOFT, DARK GRAY, SILTY CLAY, WET TO SATURATED,
TRACE WOOD FRAGMENTS, HIGHLY PLASTIC (A-7-6)

COASTAL PLAIN, LOOSE TO MEDIUM

DENSE, GRAY, SILTY COARSE TO FINE SAND, SATURATED
(A-2-4) (BLACK CREEK FORMATION)

309 + 50^{BT}
1 OF 2

-L-

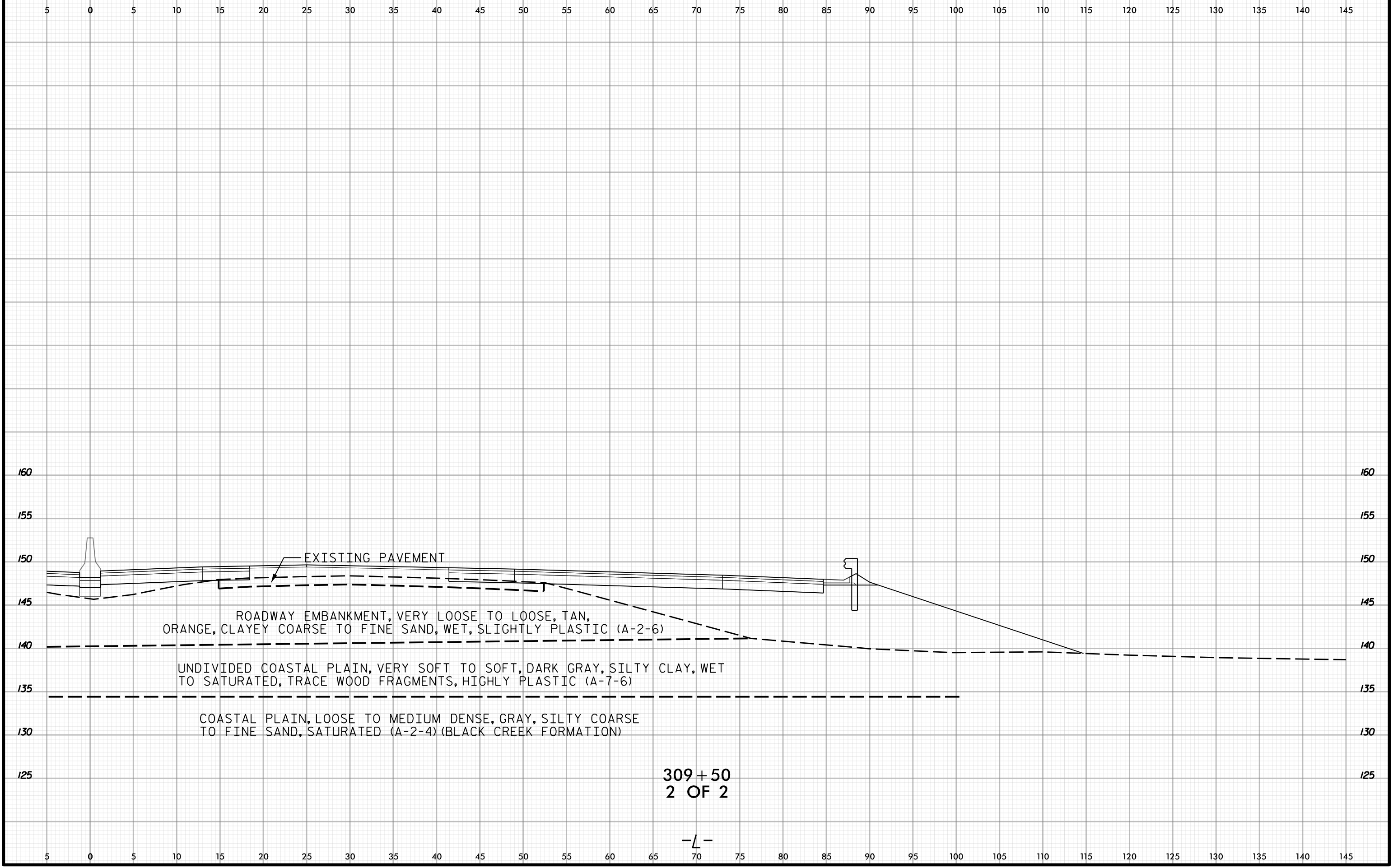

EXISTING PAVEMENT

ROADWAY EMBANKMENT, VERY LOOSE TO LOOSE, TAN,
ORANGE, CLAYEY COARSE TO FINE SAND, WET, SLIGHTLY PLASTIC (A-2-6)

UNDIVIDED COASTAL PLAIN, VERY SOFT TO SOFT, DARK GRAY, SILTY CLAY, WET
TO SATURATED, TRACE WOOD FRAGMENTS, HIGHLY PLASTIC (A-7-6)

COASTAL PLAIN, LOOSE TO MEDIUM DENSE, GRAY, SILTY COARSE
TO FINE SAND, SATURATED (A-2-4) (BLACK CREEK FORMATION)

309+50
2 OF 2

-L-

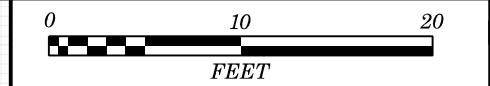

145 140 135 130 125 120 115 110 105 100 95 90 85 80 75 70 65 60 55 50 45 40 35 30 25 20 15 10 5 0 5

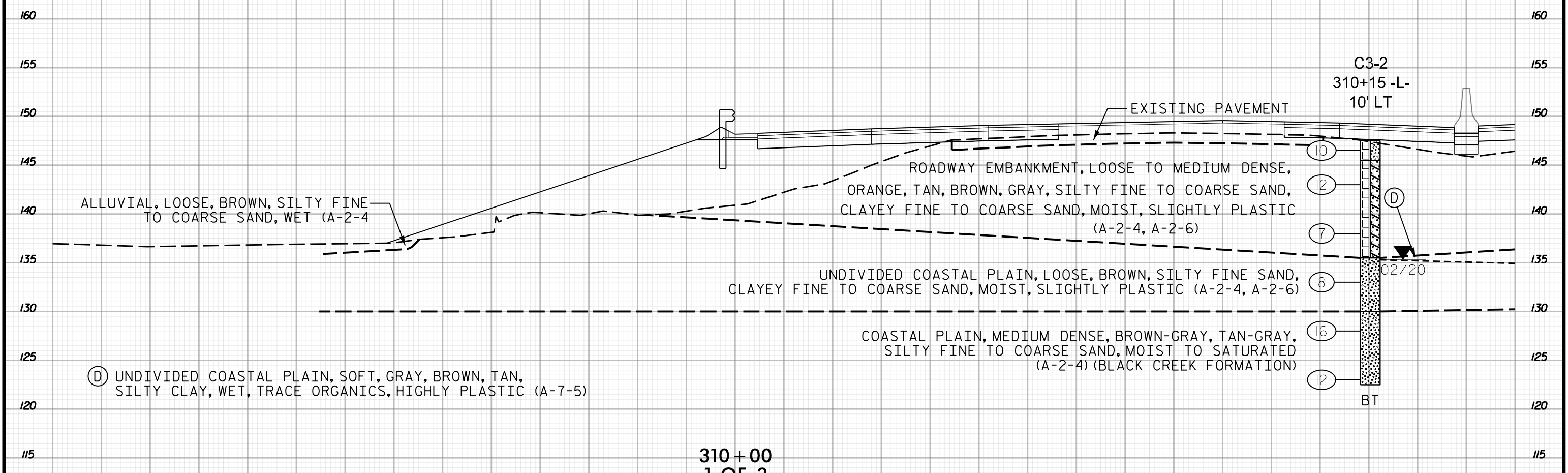

145 140 135 130 125 120 115 110 105 100 95 90 85 80 75 70 65 60 55 50 45 40 35 30 25 20 15 10 5 0 5



5 0 5 10 15 20 25 30 35 40 45 50 55 60 65 70 75 80 85 90 95 100 105 110 115 120 125 130 135 140 145

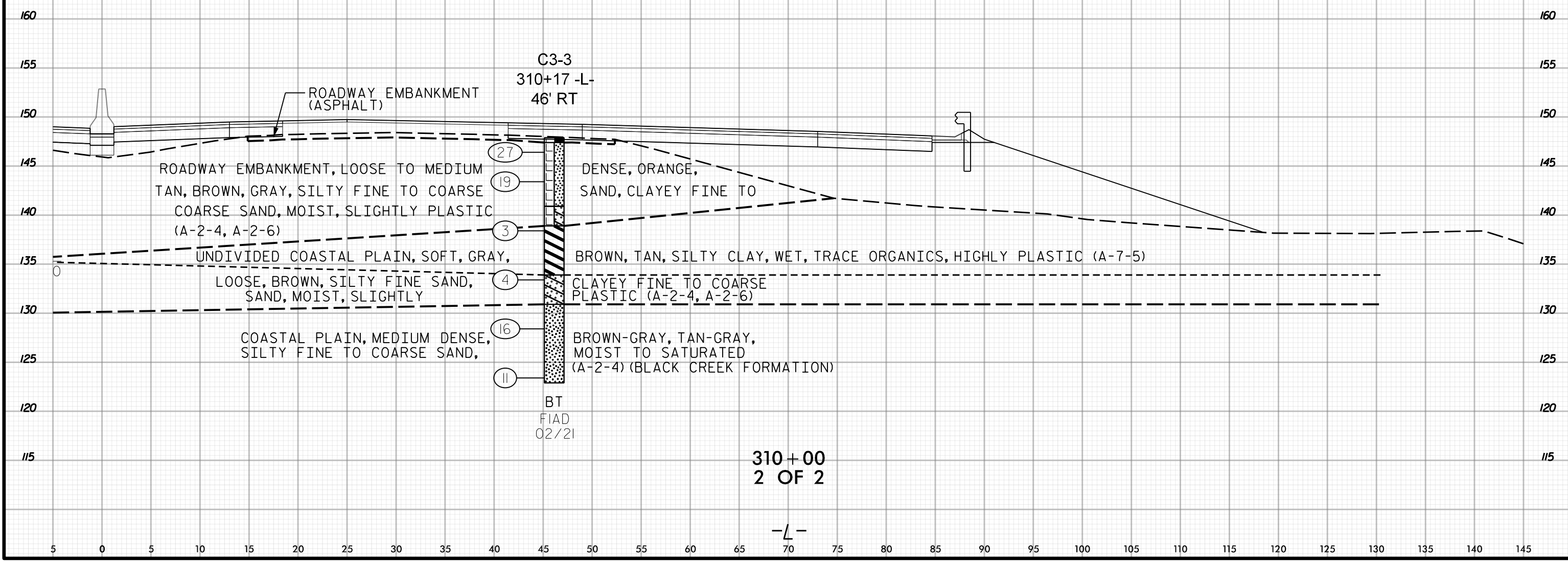

5 0 5 10 15 20 25 30 35 40 45 50 55 60 65 70 75 80 85 90 95 100 105 110 115 120 125 130 135 140 145



145 140 135 130 125 120 115 110 105 100 95 90 85 80 75 70 65 60 55 50 45 40 35 30 25 20 15 10 5 0 5

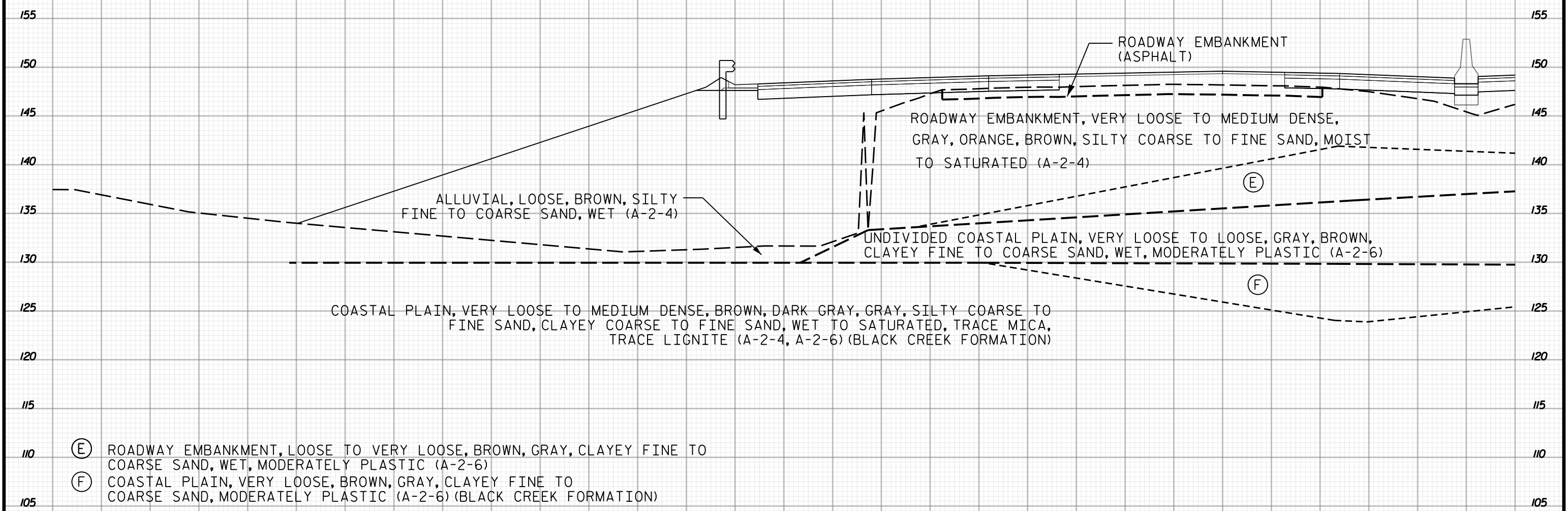

- (E) ROADWAY EMBANKMENT, LOOSE TO VERY LOOSE, BROWN, GRAY, CLAYEY FINE TO COARSE SAND, WET, MODERATELY PLASTIC (A-2-6)
- (F) COASTAL PLAIN, VERY LOOSE, BROWN, GRAY, CLAYEY FINE TO COARSE SAND, MODERATELY PLASTIC (A-2-6) (BLACK CREEK FORMATION)

310 + 50
1 OF 2

-L-

145 140 135 130 125 120 115 110 105 100 95 90 85 80 75 70 65 60 55 50 45 40 35 30 25 20 15 10 5 0 5

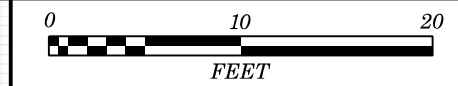

5 0 5 10 15 20 25 30 35 40 45 50 55 60 65 70 75 80 85 90 95 100 105 110 115 120 125 130 135 140 145

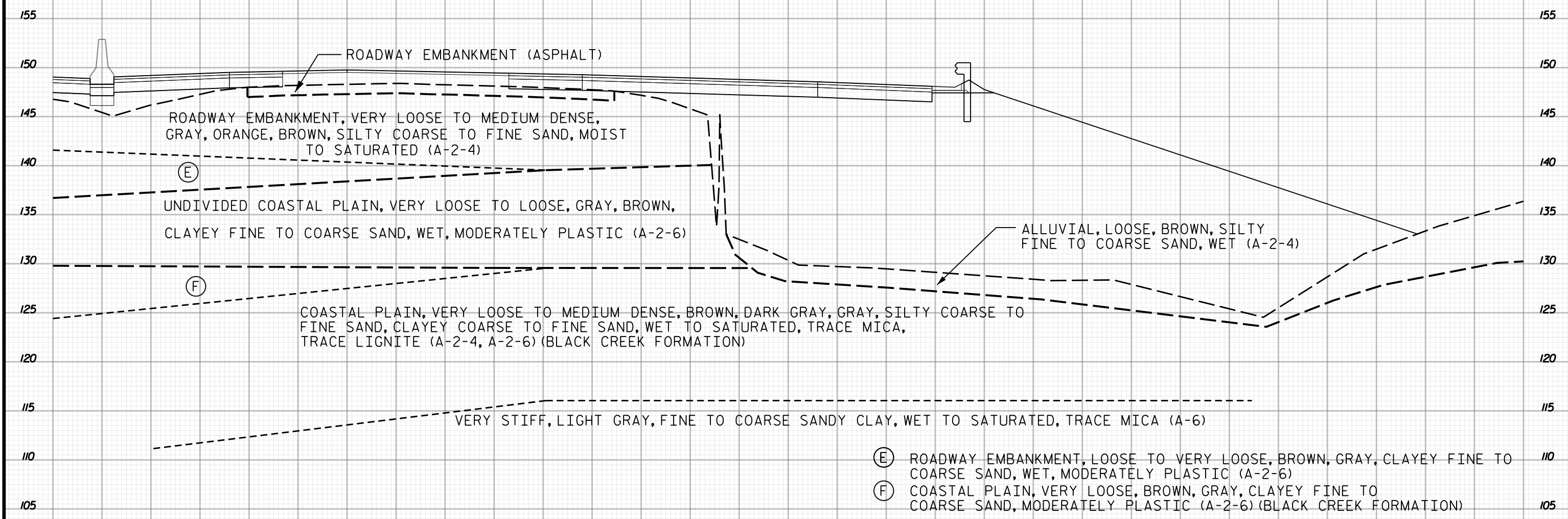

310+50
2 OF 2

-L-

5 0 5 10 15 20 25 30 35 40 45 50 55 60 65 70 75 80 85 90 95 100 105 110 115 120 125 130 135 140 145

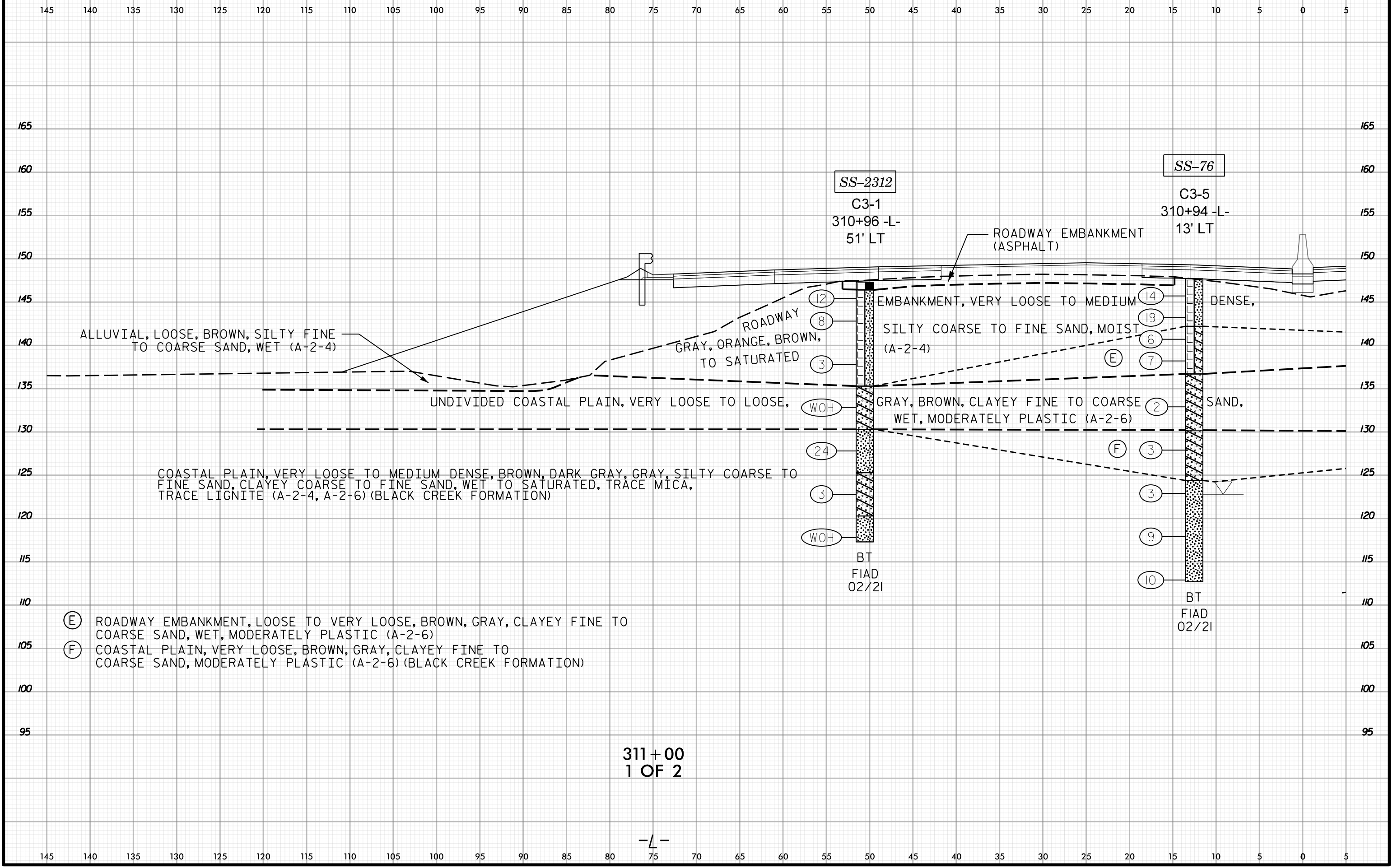
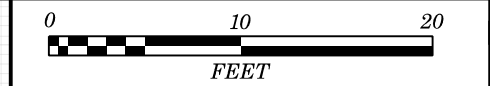

ALLUVIAL, LOOSE, BROWN, SILTY FINE TO COARSE SAND, WET (A-2-4)

ROADWAY EMBANKMENT (ASPHALT)
GRAY, ORANGE, BROWN, TO SATURATED

UNDIVIDED COASTAL PLAIN, VERY LOOSE TO LOOSE,

COASTAL PLAIN, VERY LOOSE TO MEDIUM DENSE, BROWN, DARK GRAY, GRAY, SILTY COARSE TO FINE SAND, CLAYEY COARSE TO FINE SAND, WET TO SATURATED, TRACE MICA, TRACE LIGNITE (A-2-4, A-2-6) (BLACK CREEK FORMATION)

SS-2312
C3-1
310+96 -L-
51' LT

SS-76
C3-5
310+94 -L-
13' LT

EMBANKMENT, VERY LOOSE TO MEDIUM SILTY COARSE TO FINE SAND, MOIST (A-2-4)

GRAY, BROWN, CLAYEY FINE TO COARSE SAND, WET, MODERATELY PLASTIC (A-2-6)

DENSE,

SAND,

- (E) ROADWAY EMBANKMENT, LOOSE TO VERY LOOSE, BROWN, GRAY, CLAYEY FINE TO COARSE SAND, WET, MODERATELY PLASTIC (A-2-6)
- (F) COASTAL PLAIN, VERY LOOSE, BROWN, GRAY, CLAYEY FINE TO COARSE SAND, MODERATELY PLASTIC (A-2-6) (BLACK CREEK FORMATION)

311+00
1 OF 2

-L-

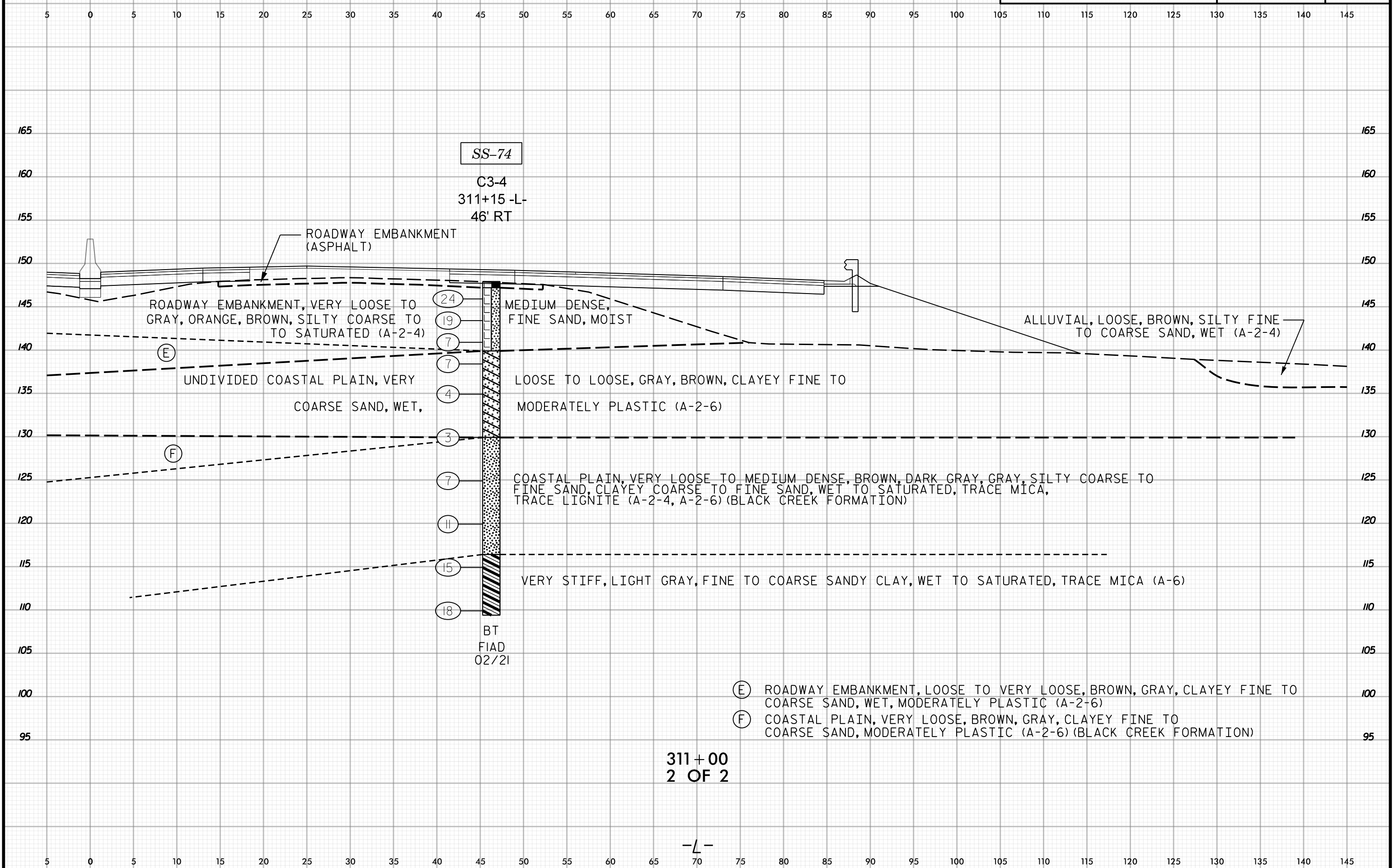

SS-74
C3-4
311+15 -L-
46' RT

- (24)
- (19)
- (7)
- (7)
- (4)
- (3)
- (7)
- (11)
- (15)
- (18)

BT
FIAD
02/21

- (E) ROADWAY EMBANKMENT, LOOSE TO VERY LOOSE, BROWN, GRAY, CLAYEY FINE TO COARSE SAND, WET, MODERATELY PLASTIC (A-2-6)
- (F) COASTAL PLAIN, VERY LOOSE, BROWN, GRAY, CLAYEY FINE TO COARSE SAND, MODERATELY PLASTIC (A-2-6) (BLACK CREEK FORMATION)

311+00
2 OF 2

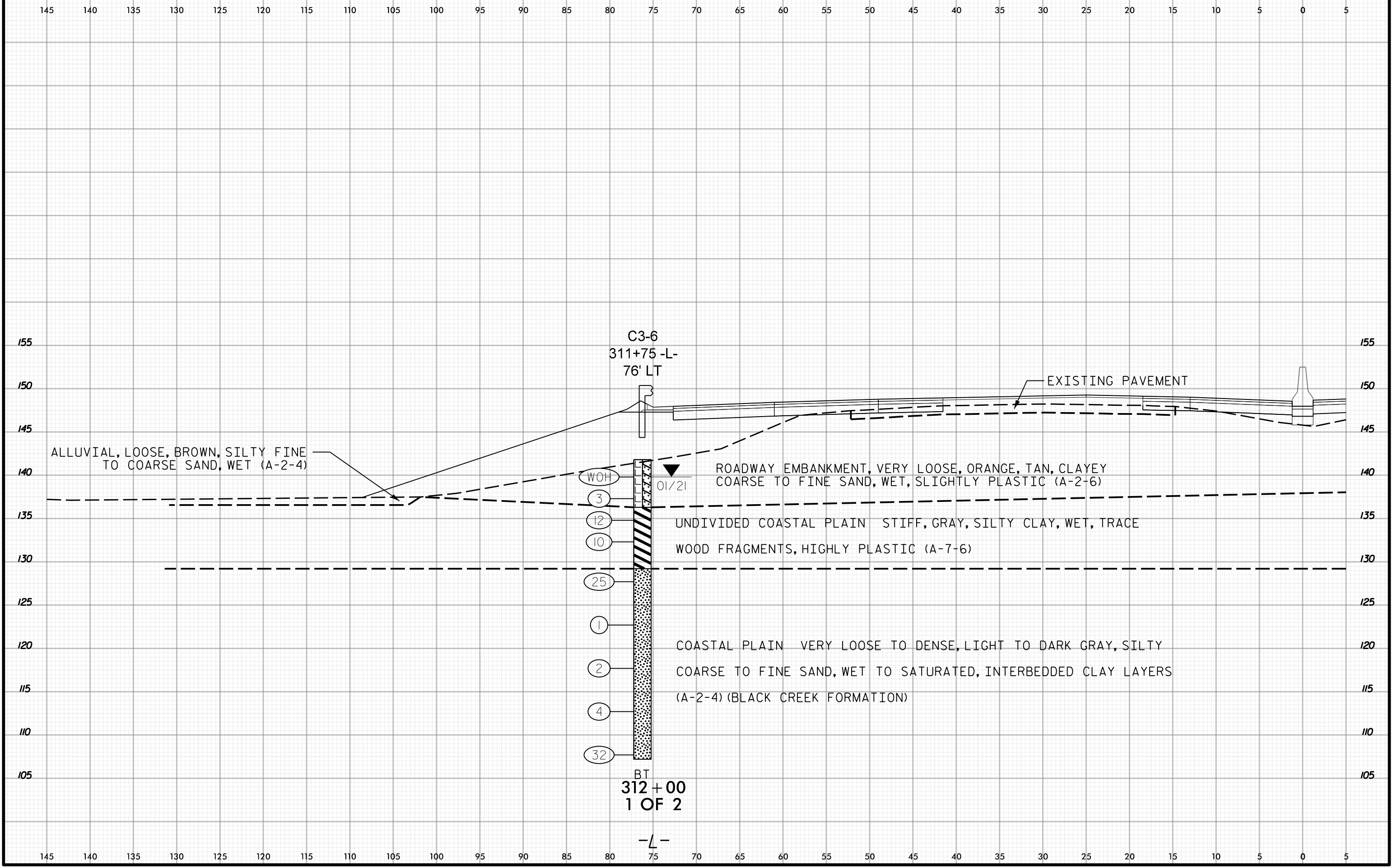

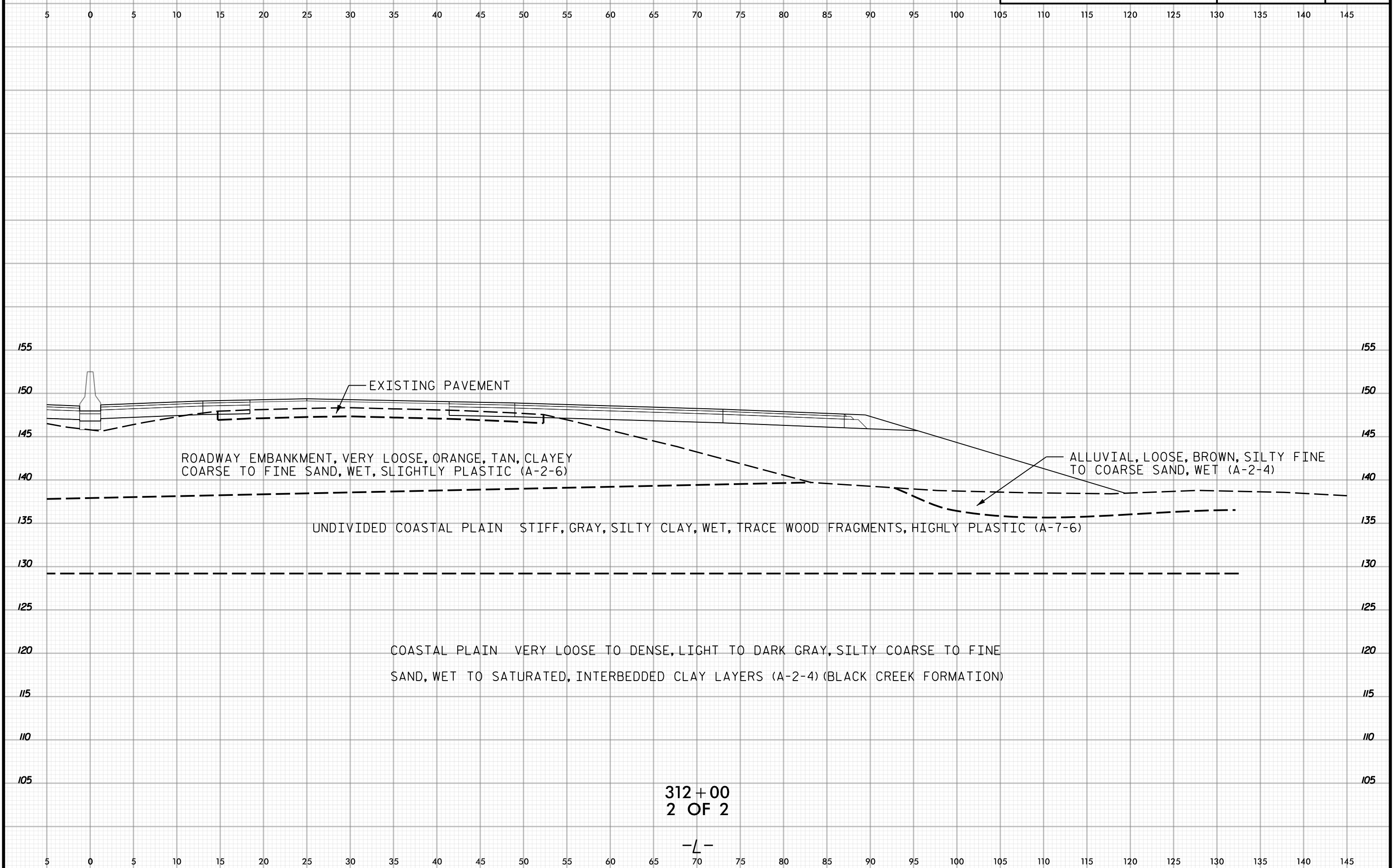



145 140 135 130 125 120 115 110 105 100 95 90 85 80 75 70 65 60 55 50 45 40 35 30 25 20 15 10 5 0 5

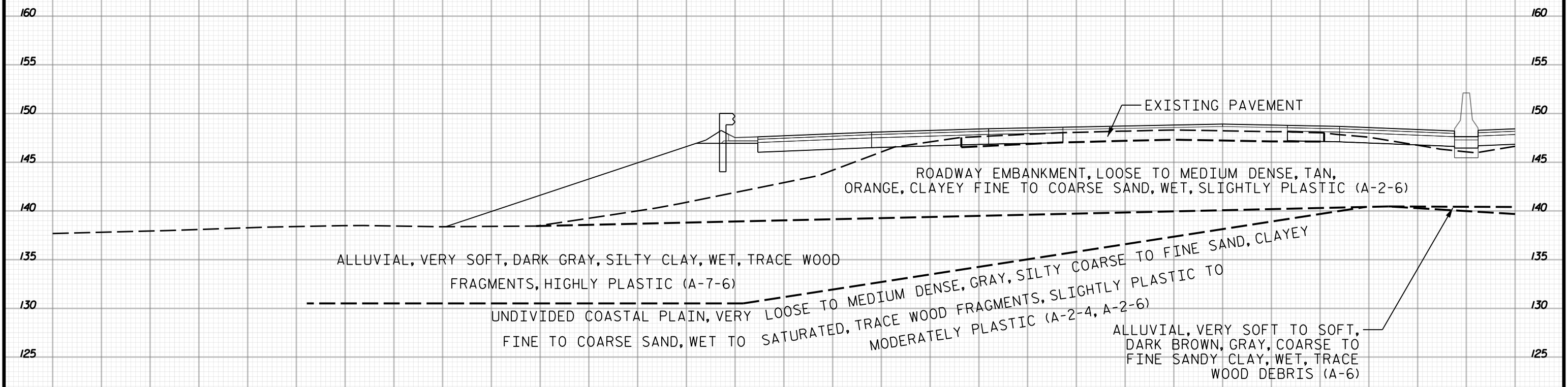

313 + 00

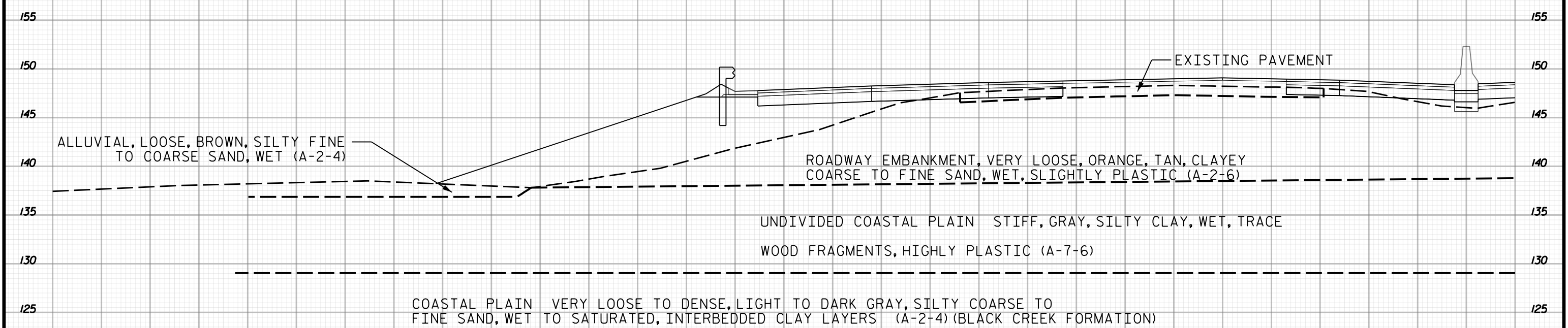

312 + 50
1 OF 2

145 140 135 130 125 120 115 110 105 100 95 90 85 80 75 70 65 60 55 50 45 40 35 30 25 20 15 10 5 0 5

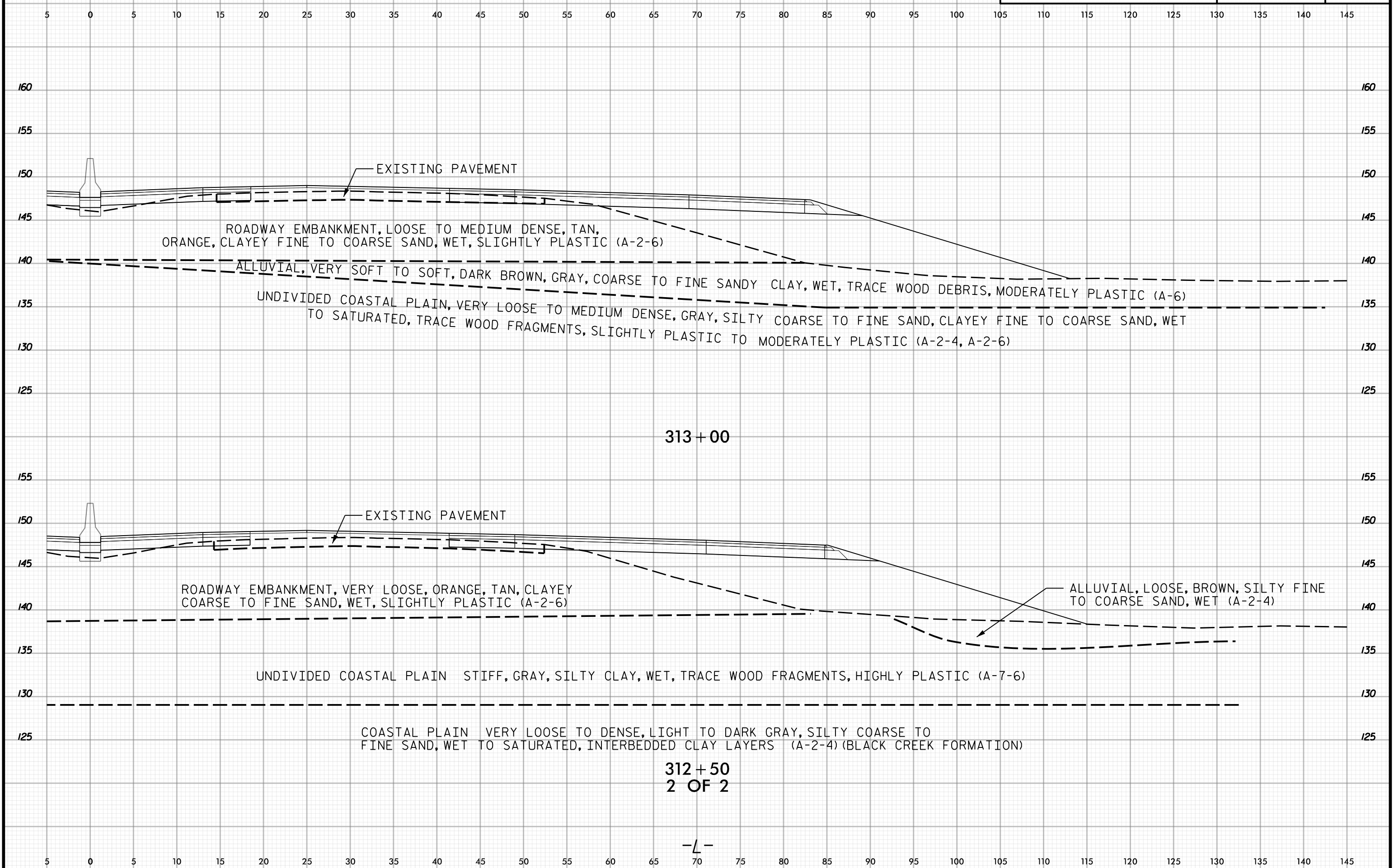

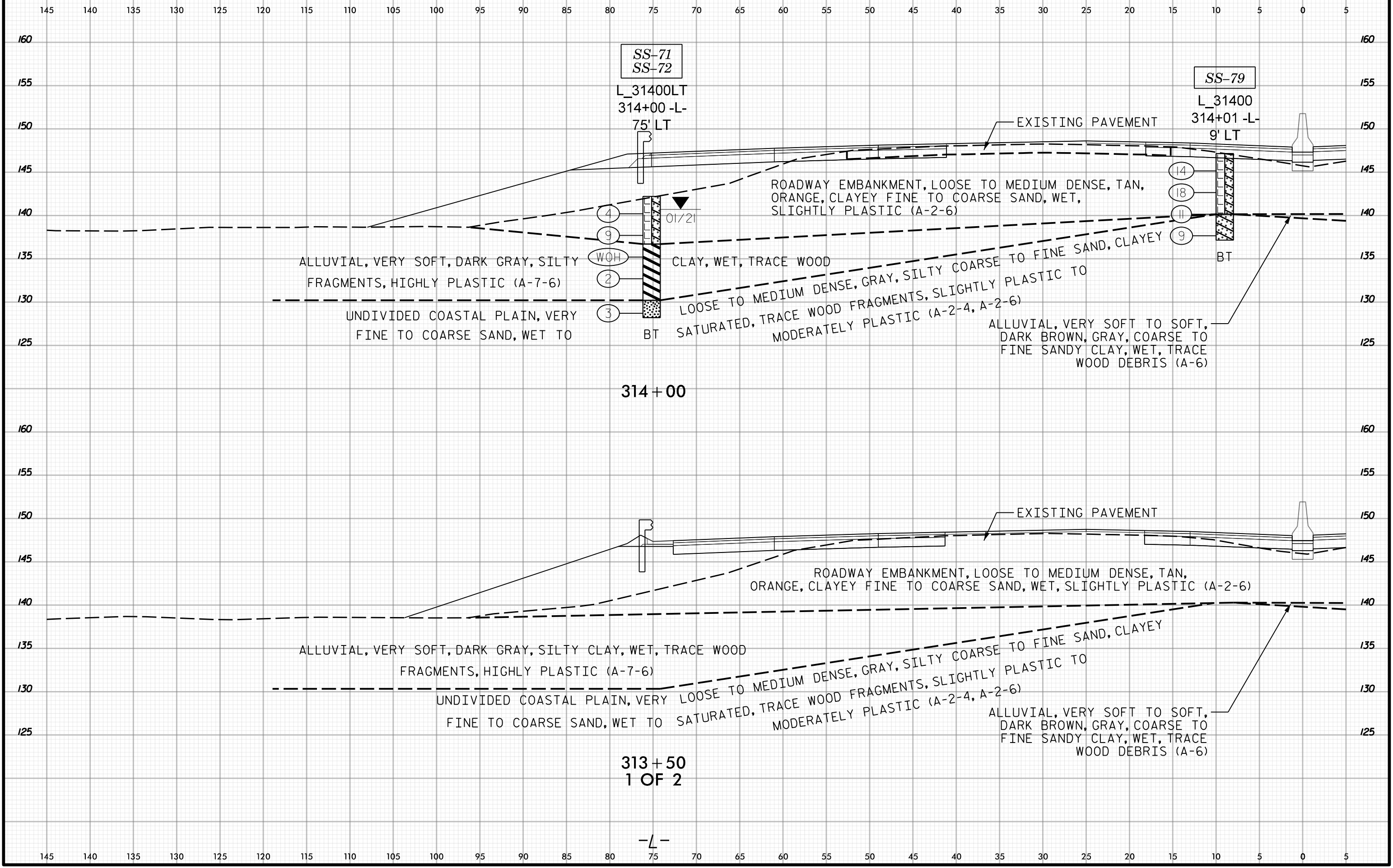
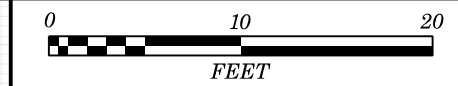

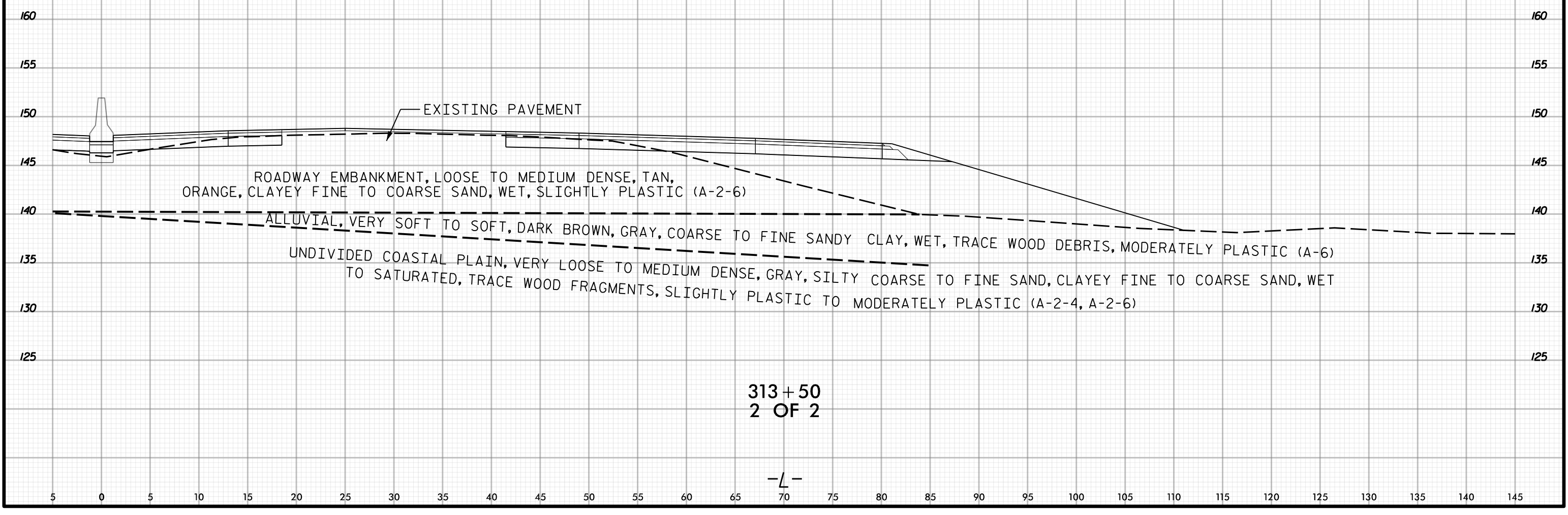
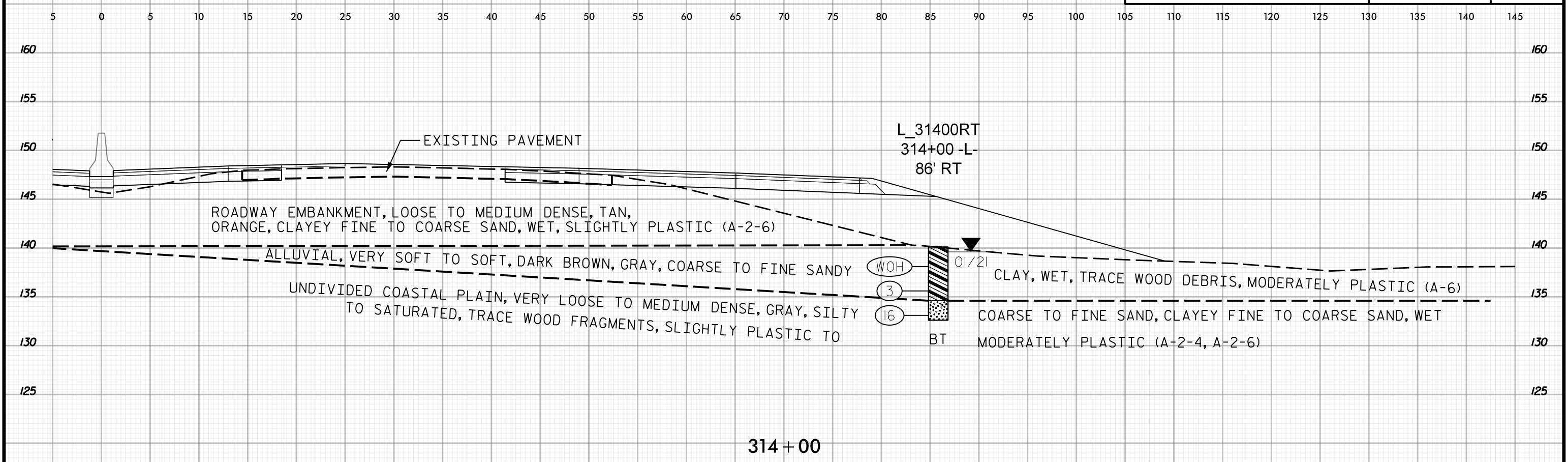
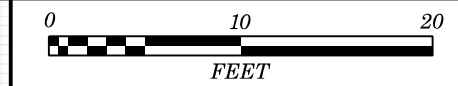

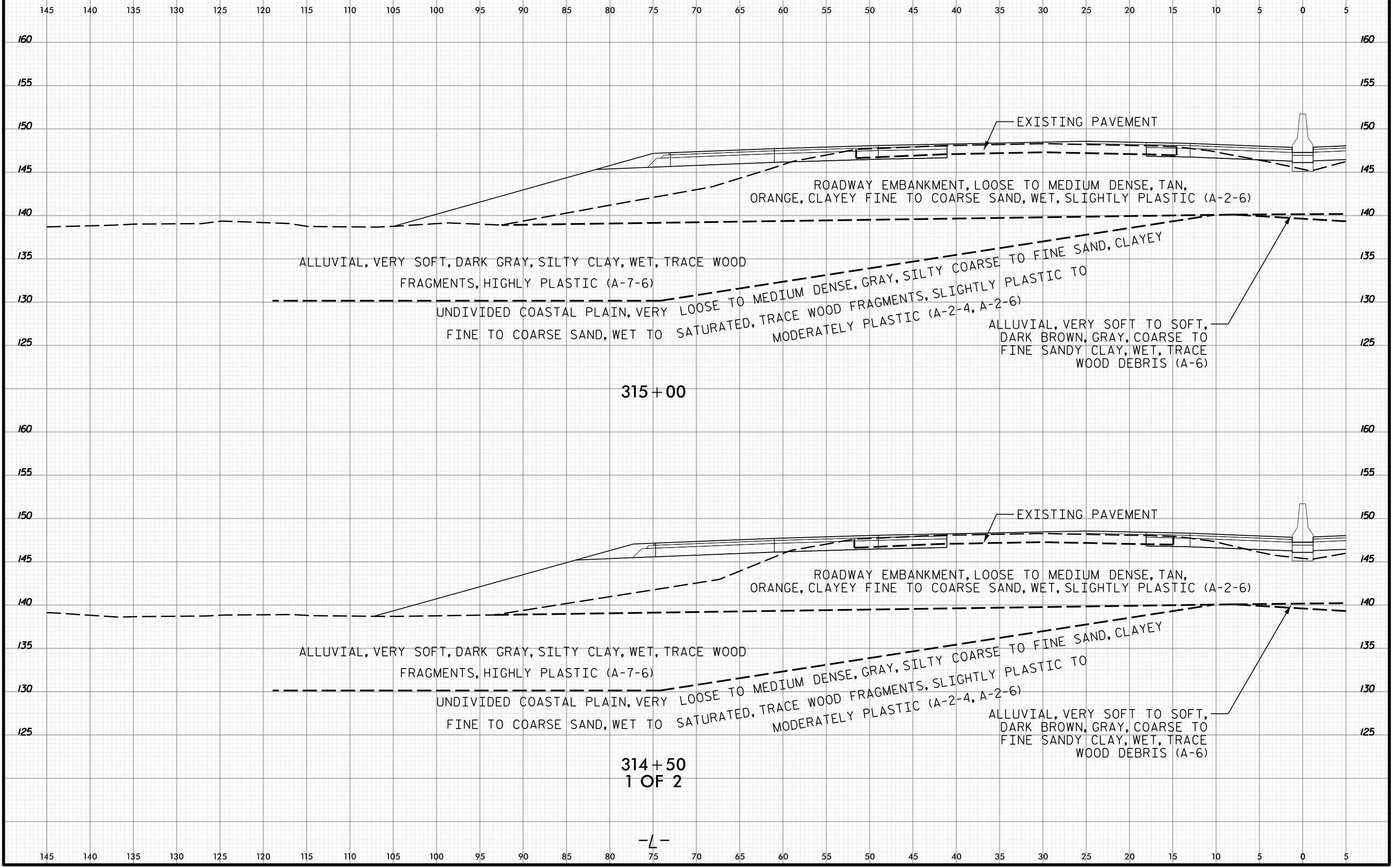

ALLUVIAL, VERY SOFT, DARK GRAY, SILTY CLAY, WET, TRACE WOOD FRAGMENTS, HIGHLY PLASTIC (A-7-6)

UNDIVIDED COASTAL PLAIN, VERY LOOSE TO MEDIUM DENSE, GRAY, SILTY COARSE TO FINE SAND, CLAYEY FINE TO COARSE SAND, WET TO SATURATED, TRACE WOOD FRAGMENTS, SLIGHTLY PLASTIC TO MODERATELY PLASTIC (A-2-4, A-2-6)

ALLUVIAL, VERY SOFT TO SOFT, DARK BROWN, GRAY, COARSE TO FINE SANDY CLAY, WET, TRACE WOOD DEBRIS (A-6)

ROADWAY EMBANKMENT, LOOSE TO MEDIUM DENSE, TAN, ORANGE, CLAYEY FINE TO COARSE SAND, WET, SLIGHTLY PLASTIC (A-2-6)

EXISTING PAVEMENT

315+00

314+50
1 OF 2

-L-

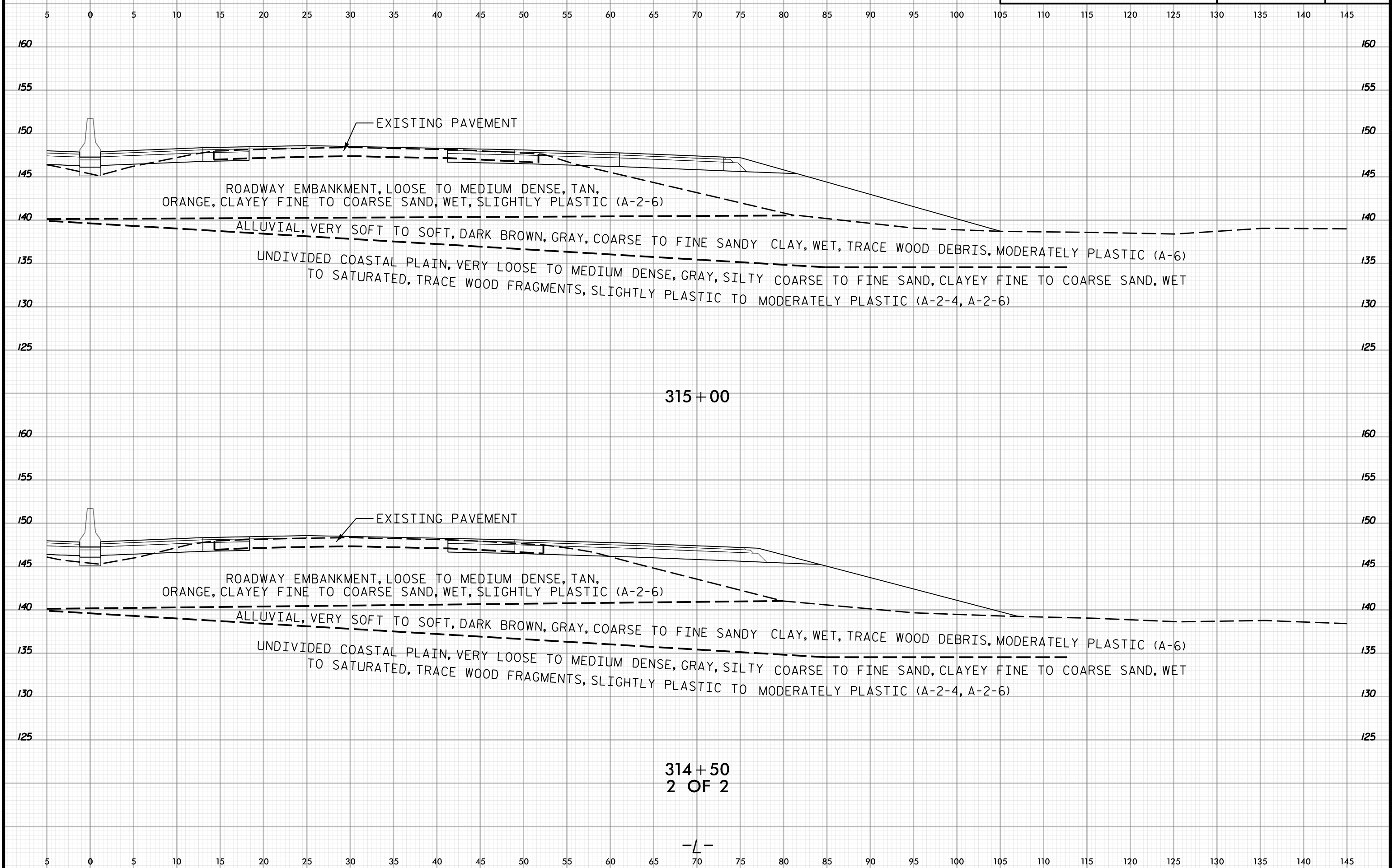

315+00

314+50
2 OF 2

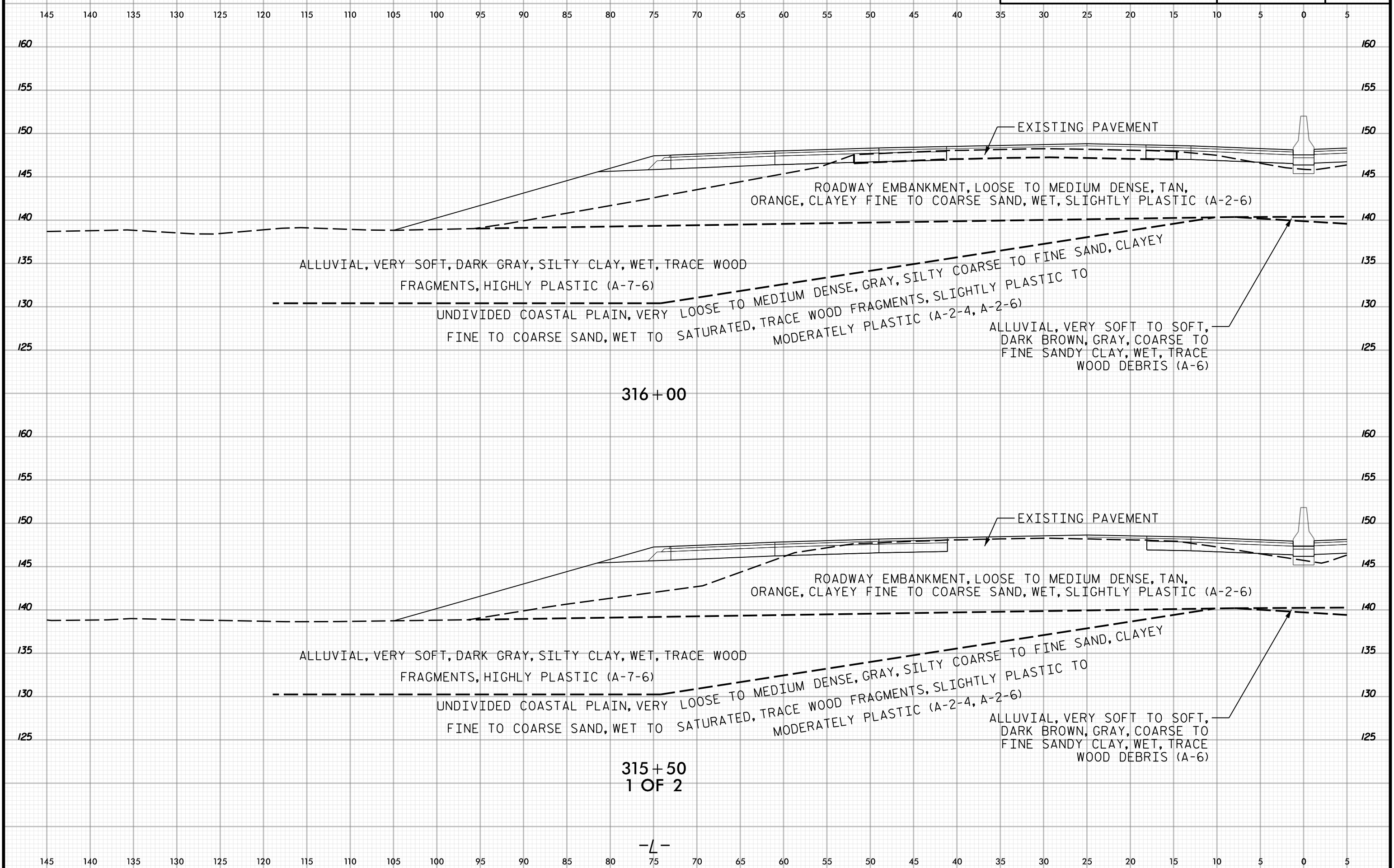

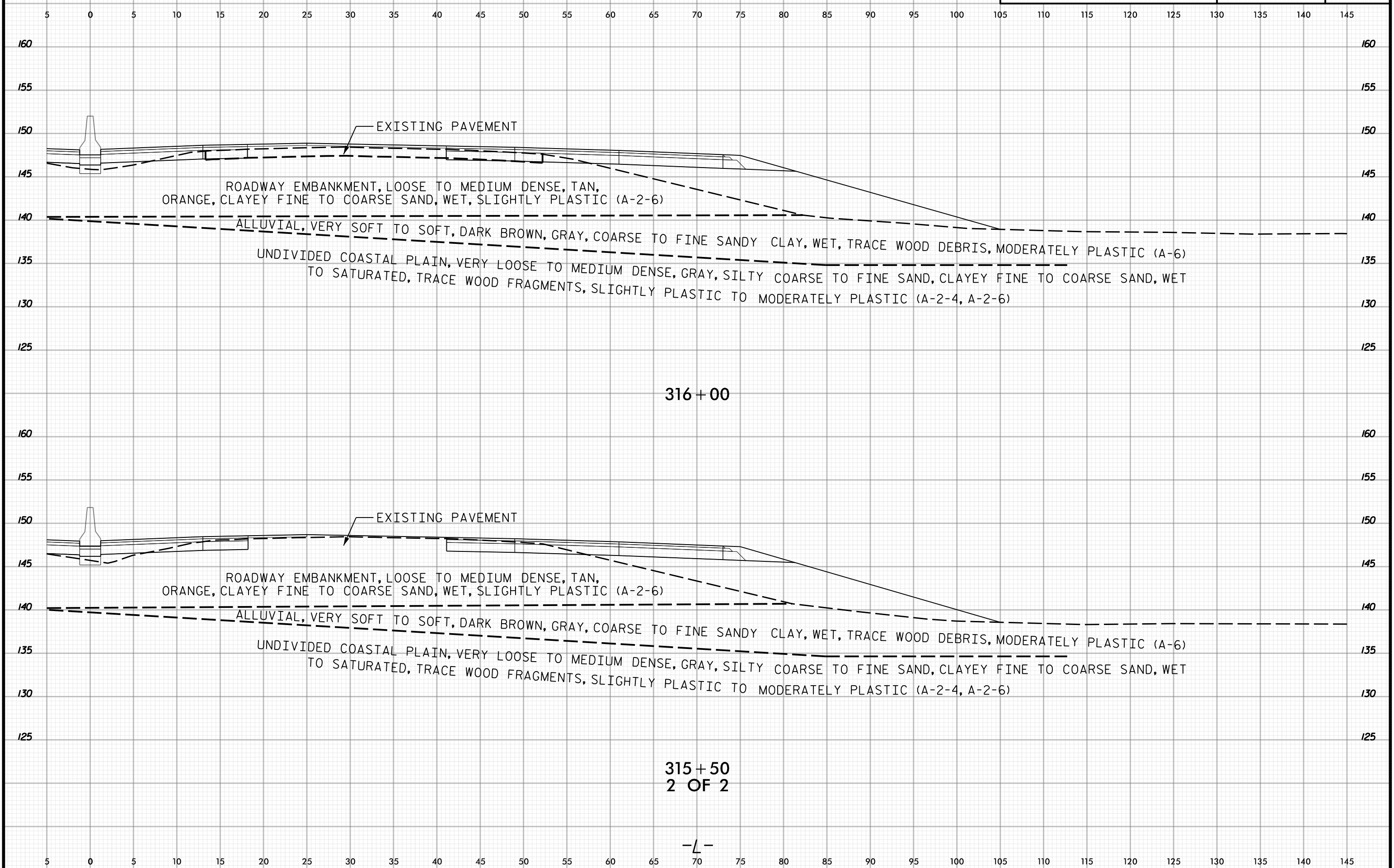

EXISTING PAVEMENT

ROADWAY EMBANKMENT, LOOSE TO MEDIUM DENSE, TAN, ORANGE, CLAYEY FINE TO COARSE SAND, WET, SLIGHTLY PLASTIC (A-2-6)

ALLUVIAL, VERY SOFT TO SOFT, DARK BROWN, GRAY, COARSE TO FINE SANDY CLAY, WET, TRACE WOOD DEBRIS, MODERATELY PLASTIC (A-6)

UNDIVIDED COASTAL PLAIN, VERY LOOSE TO MEDIUM DENSE, GRAY, SILTY COARSE TO FINE SAND, CLAYEY FINE TO COARSE SAND, WET TO SATURATED, TRACE WOOD FRAGMENTS, SLIGHTLY PLASTIC TO MODERATELY PLASTIC (A-2-4, A-2-6)

316+00

EXISTING PAVEMENT

ROADWAY EMBANKMENT, LOOSE TO MEDIUM DENSE, TAN, ORANGE, CLAYEY FINE TO COARSE SAND, WET, SLIGHTLY PLASTIC (A-2-6)

ALLUVIAL, VERY SOFT TO SOFT, DARK BROWN, GRAY, COARSE TO FINE SANDY CLAY, WET, TRACE WOOD DEBRIS, MODERATELY PLASTIC (A-6)

UNDIVIDED COASTAL PLAIN, VERY LOOSE TO MEDIUM DENSE, GRAY, SILTY COARSE TO FINE SAND, CLAYEY FINE TO COARSE SAND, WET TO SATURATED, TRACE WOOD FRAGMENTS, SLIGHTLY PLASTIC TO MODERATELY PLASTIC (A-2-4, A-2-6)

315+50
2 OF 2

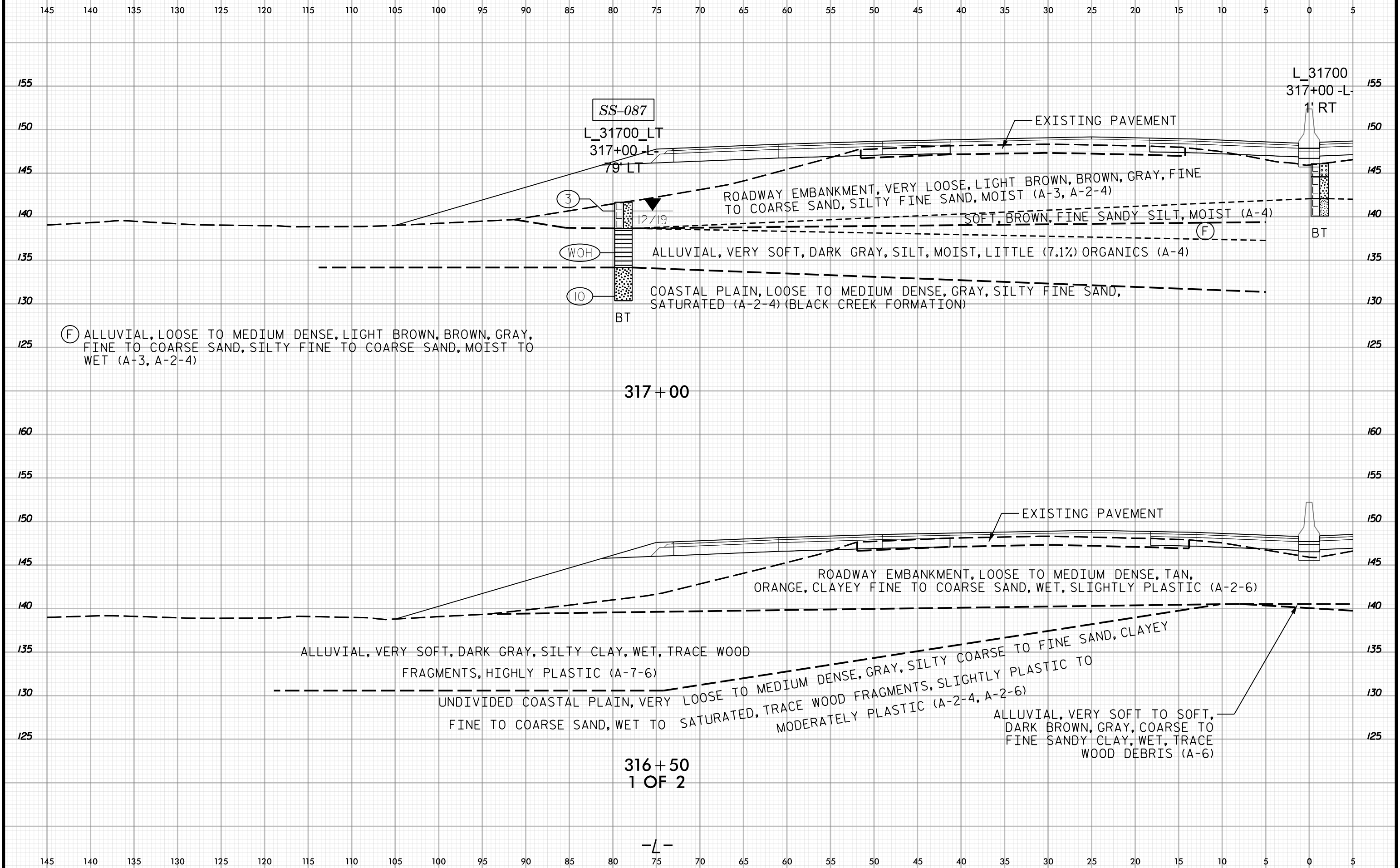
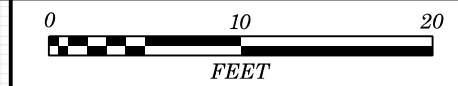

SS-087

L_31700_LT
317+00-L

79' LT

(3)

12/19

(WOH)

(10)

BT

L_31700
317+00-L

1' RT

BT

EXISTING PAVEMENT

ROADWAY EMBANKMENT, VERY LOOSE, LIGHT BROWN, BROWN, GRAY, FINE TO COARSE SAND, SILTY FINE SAND, MOIST (A-3, A-2-4)

SOFT, BROWN, FINE SANDY SILT, MOIST (A-4)

ALLUVIAL, VERY SOFT, DARK GRAY, SILT, MOIST, LITTLE (7.1%) ORGANICS (A-4)

COASTAL PLAIN, LOOSE TO MEDIUM DENSE, GRAY, SILTY FINE SAND, SATURATED (A-2-4) (BLACK CREEK FORMATION)

(F) ALLUVIAL, LOOSE TO MEDIUM DENSE, LIGHT BROWN, BROWN, GRAY, FINE TO COARSE SAND, SILTY FINE TO COARSE SAND, MOIST TO WET (A-3, A-2-4)

317+00

EXISTING PAVEMENT

ROADWAY EMBANKMENT, LOOSE TO MEDIUM DENSE, TAN, ORANGE, CLAYEY FINE TO COARSE SAND, WET, SLIGHTLY PLASTIC (A-2-6)

ALLUVIAL, VERY SOFT, DARK GRAY, SILTY CLAY, WET, TRACE WOOD FRAGMENTS, HIGHLY PLASTIC (A-7-6)

UNDIVIDED COASTAL PLAIN, VERY LOOSE TO MEDIUM DENSE, GRAY, SILTY COARSE TO FINE SAND, CLAYEY FINE TO COARSE SAND, WET TO SATURATED, TRACE WOOD FRAGMENTS, SLIGHTLY PLASTIC TO MODERATELY PLASTIC (A-2-4, A-2-6)

ALLUVIAL, VERY SOFT TO SOFT, DARK BROWN, GRAY, COARSE TO FINE SANDY CLAY, WET, TRACE WOOD DEBRIS (A-6)

316+50
1 OF 2

-L-

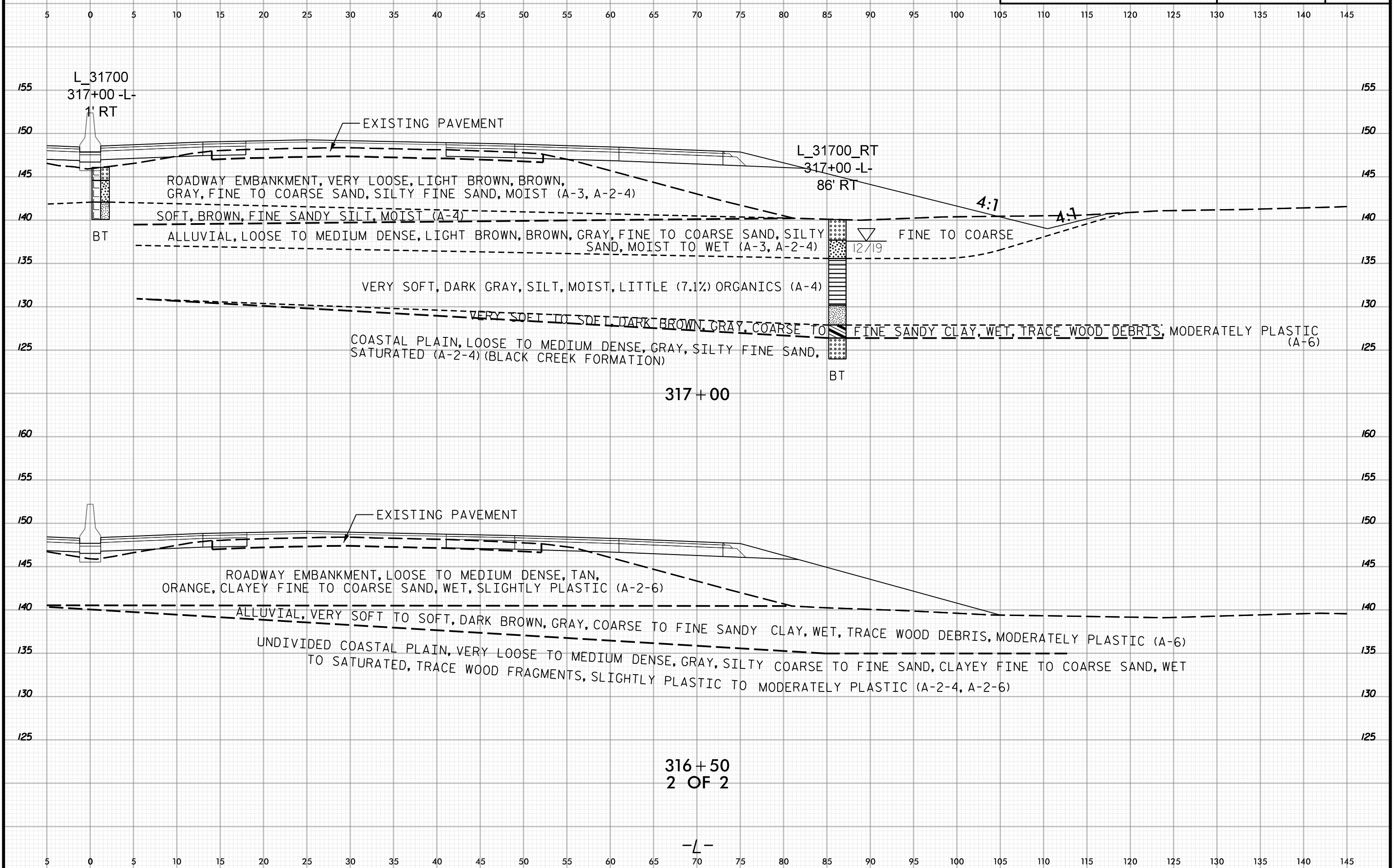
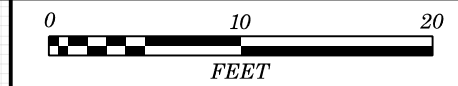



145 140 135 130 125 120 115 110 105 100 95 90 85 80 75 70 65 60 55 50 45 40 35 30 25 20 15 10 5 0 5

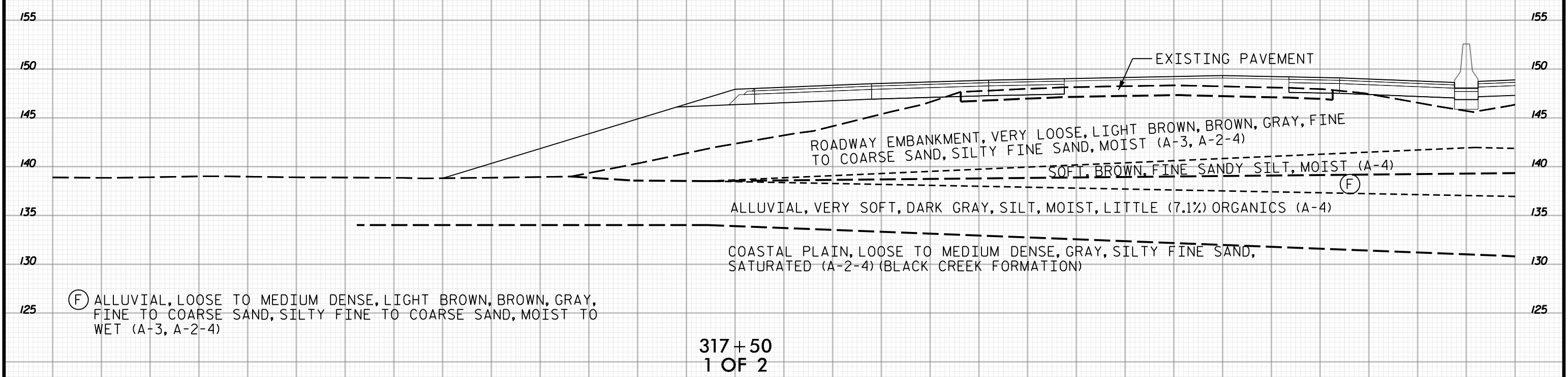
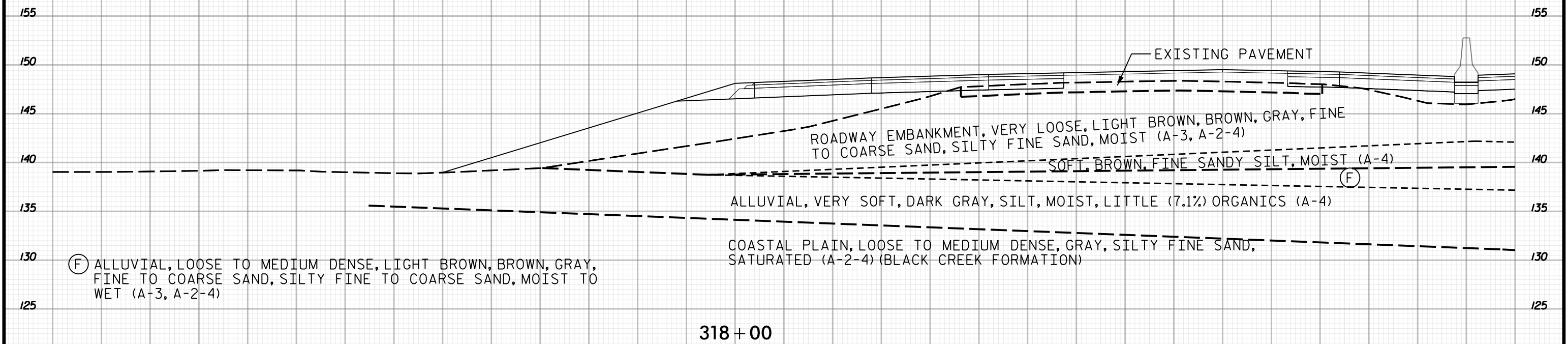

145 140 135 130 125 120 115 110 105 100 95 90 85 80 75 70 65 60 55 50 45 40 35 30 25 20 15 10 5 0 5

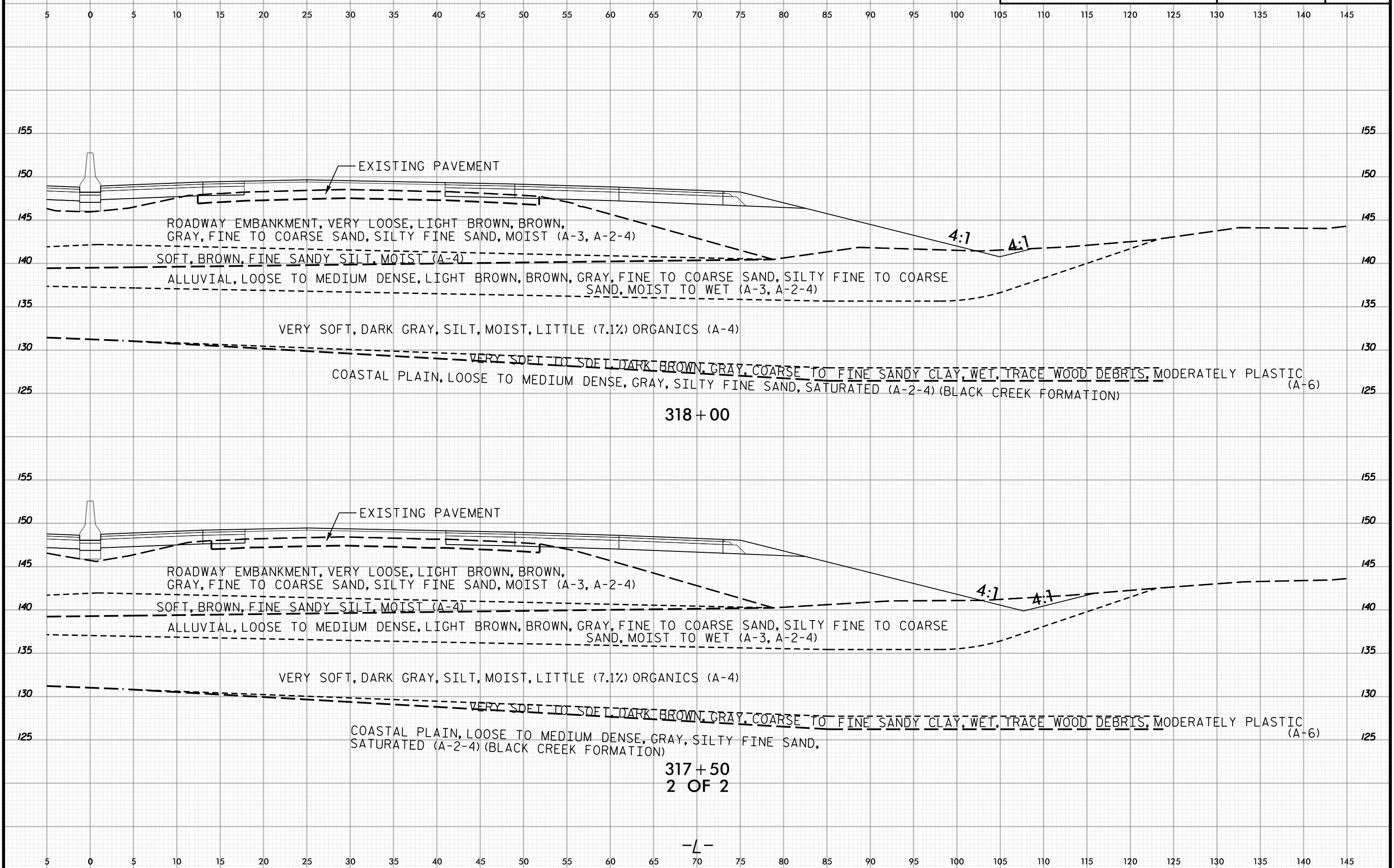

EXISTING PAVEMENT

ROADWAY EMBANKMENT, VERY LOOSE, LIGHT BROWN, BROWN, GRAY, FINE TO COARSE SAND, SILTY FINE SAND, MOIST (A-3, A-2-4)

SOFT, BROWN, FINE SANDY SILT, MOIST (A-4)

ALLUVIAL, LOOSE TO MEDIUM DENSE, LIGHT BROWN, BROWN, GRAY, FINE TO COARSE SAND, SILTY FINE TO COARSE SAND, MOIST TO WET (A-3, A-2-4)

VERY SOFT, DARK GRAY, SILT, MOIST, LITTLE (7.1%) ORGANICS (A-4)

~~VERY SOFT TO SOFT, DARK BROWN, GRAY, COARSE TO FINE SANDY CLAY, WET, TRACE WOOD DEBRIS, MODERATELY PLASTIC (A-6)~~
 COASTAL PLAIN, LOOSE TO MEDIUM DENSE, GRAY, SILTY FINE SAND, SATURATED (A-2-4) (BLACK CREEK FORMATION)

318+00

EXISTING PAVEMENT

ROADWAY EMBANKMENT, VERY LOOSE, LIGHT BROWN, BROWN, GRAY, FINE TO COARSE SAND, SILTY FINE SAND, MOIST (A-3, A-2-4)

SOFT, BROWN, FINE SANDY SILT, MOIST (A-4)

ALLUVIAL, LOOSE TO MEDIUM DENSE, LIGHT BROWN, BROWN, GRAY, FINE TO COARSE SAND, SILTY FINE TO COARSE SAND, MOIST TO WET (A-3, A-2-4)

VERY SOFT, DARK GRAY, SILT, MOIST, LITTLE (7.1%) ORGANICS (A-4)

~~VERY SOFT TO SOFT, DARK BROWN, GRAY, COARSE TO FINE SANDY CLAY, WET, TRACE WOOD DEBRIS, MODERATELY PLASTIC (A-6)~~
 COASTAL PLAIN, LOOSE TO MEDIUM DENSE, GRAY, SILTY FINE SAND, SATURATED (A-2-4) (BLACK CREEK FORMATION)

317+50

2 OF 2

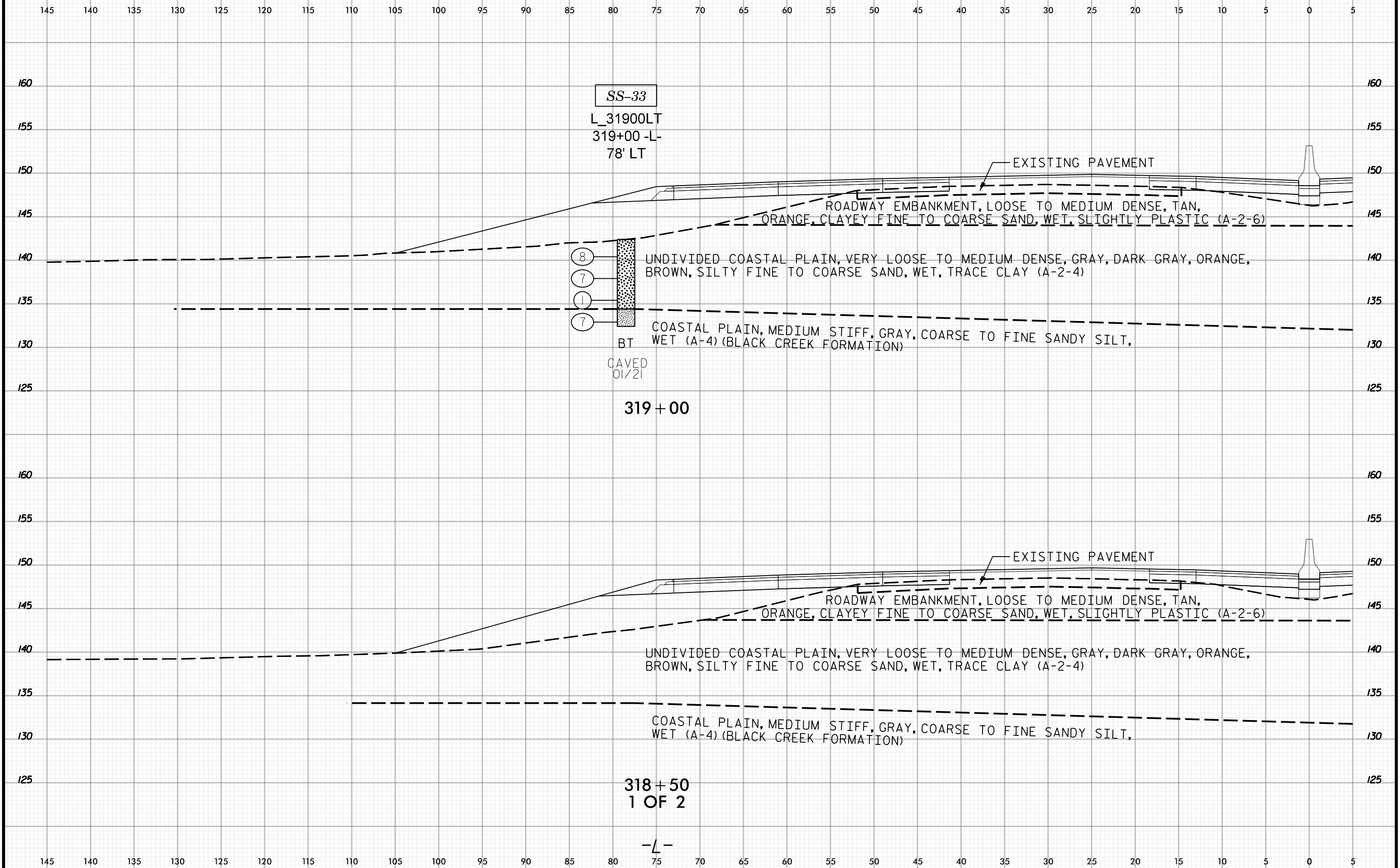
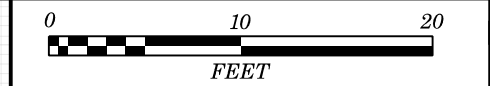

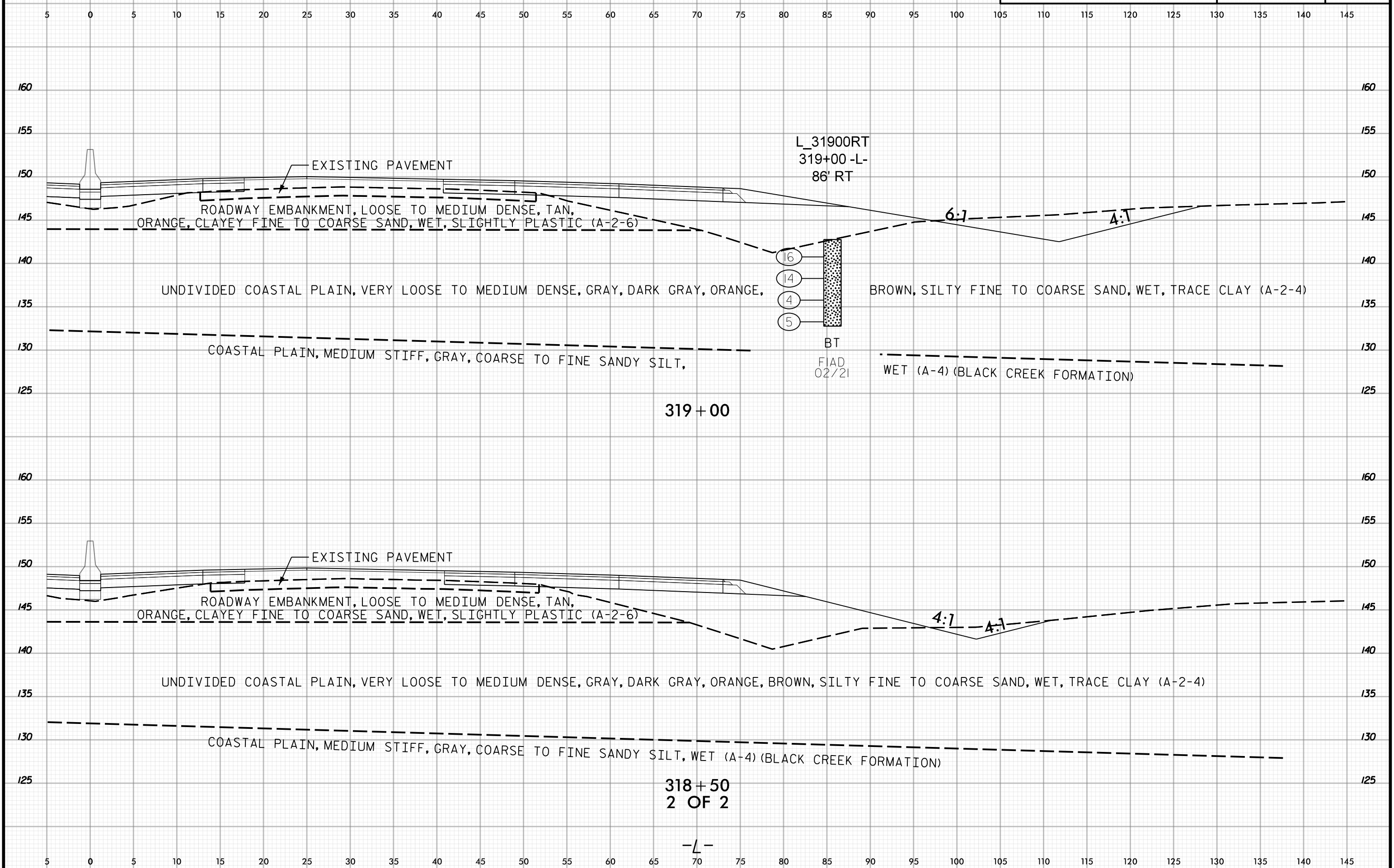

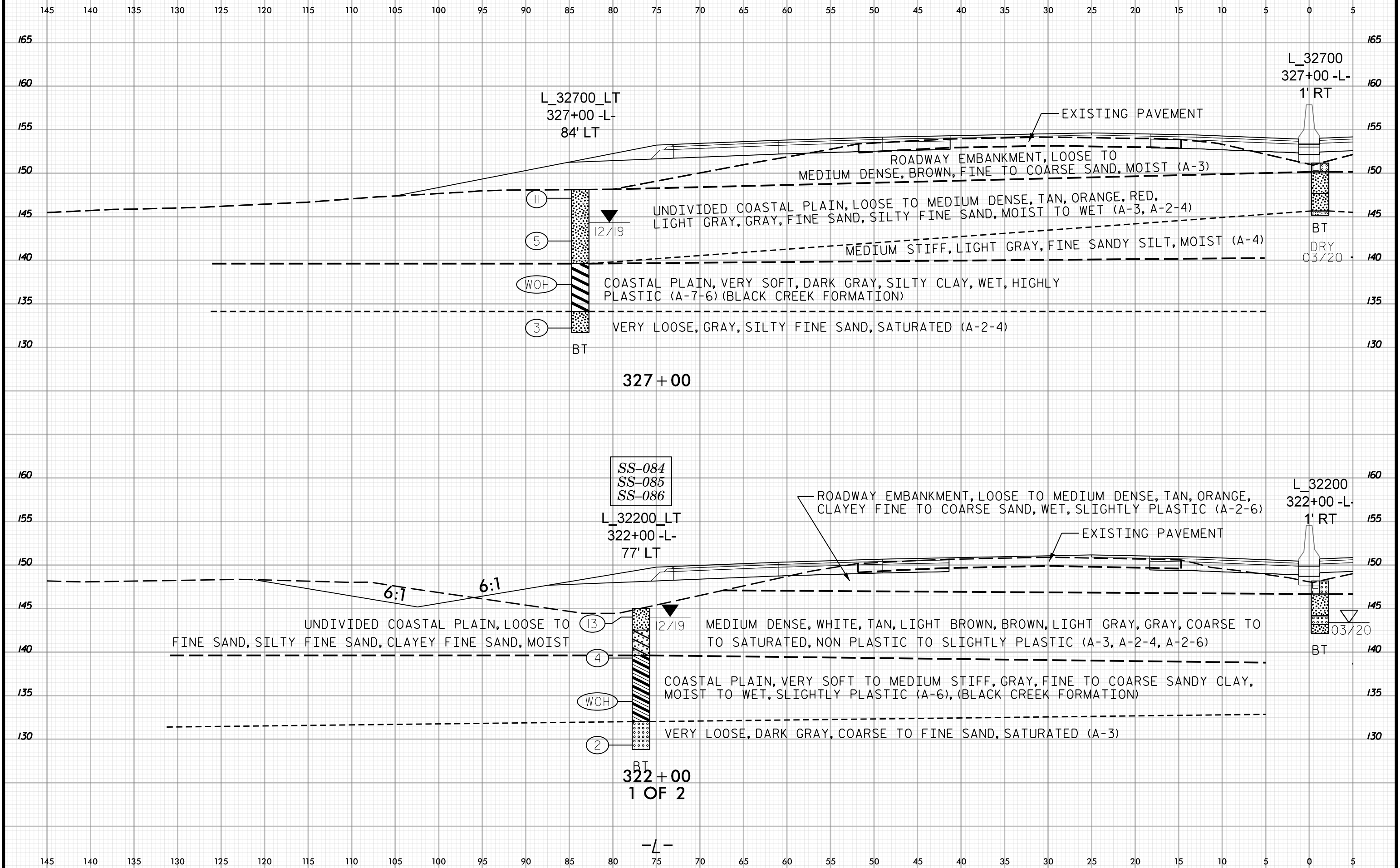
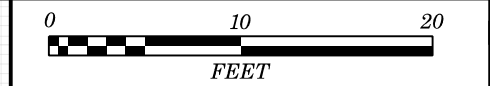

327+00

SS-084
SS-085
SS-086

L_32200_LT
322+00 -L-
77' LT

BT
322+00
1 OF 2

-L-

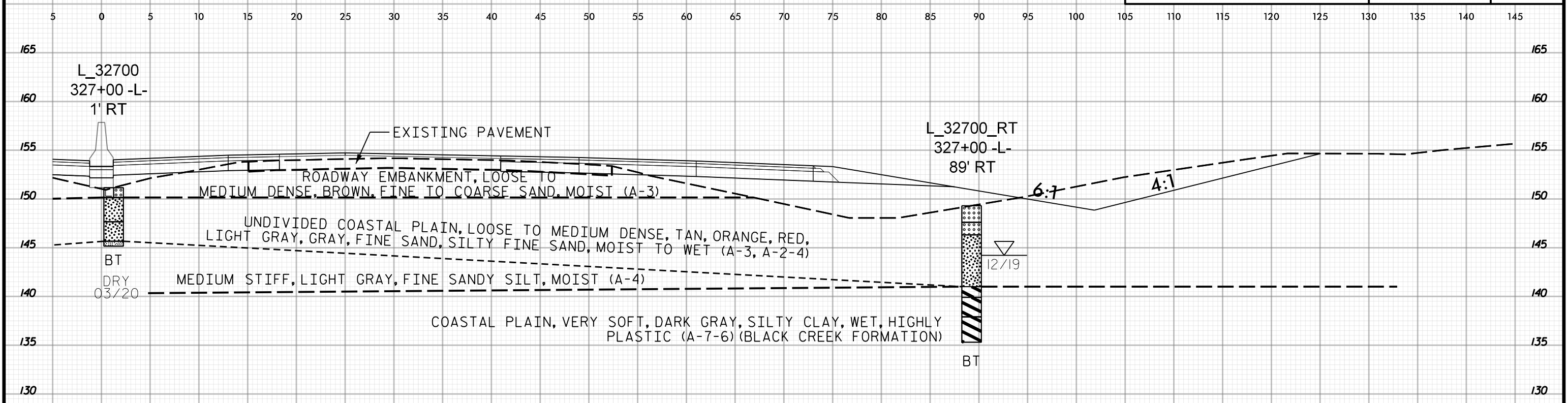
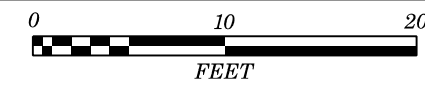

327+00

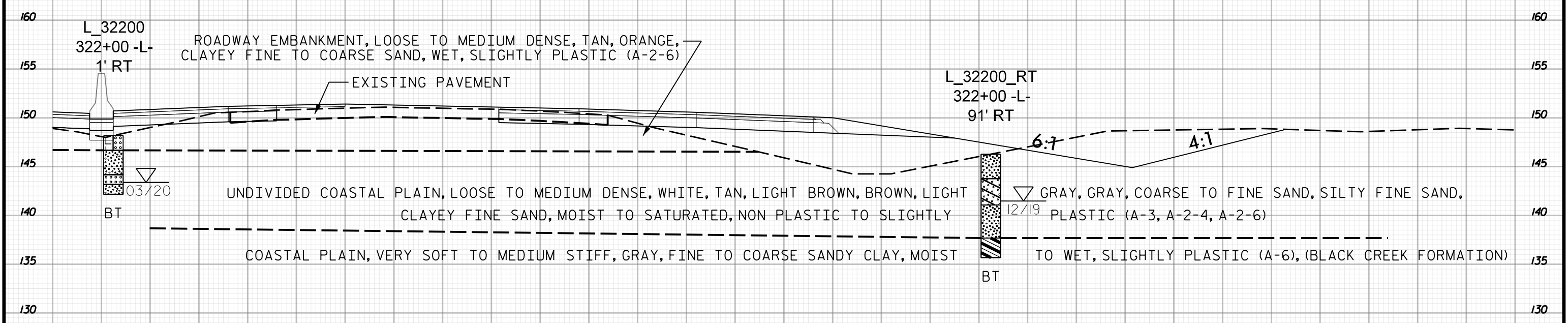

322+00
2 OF 2

-L-

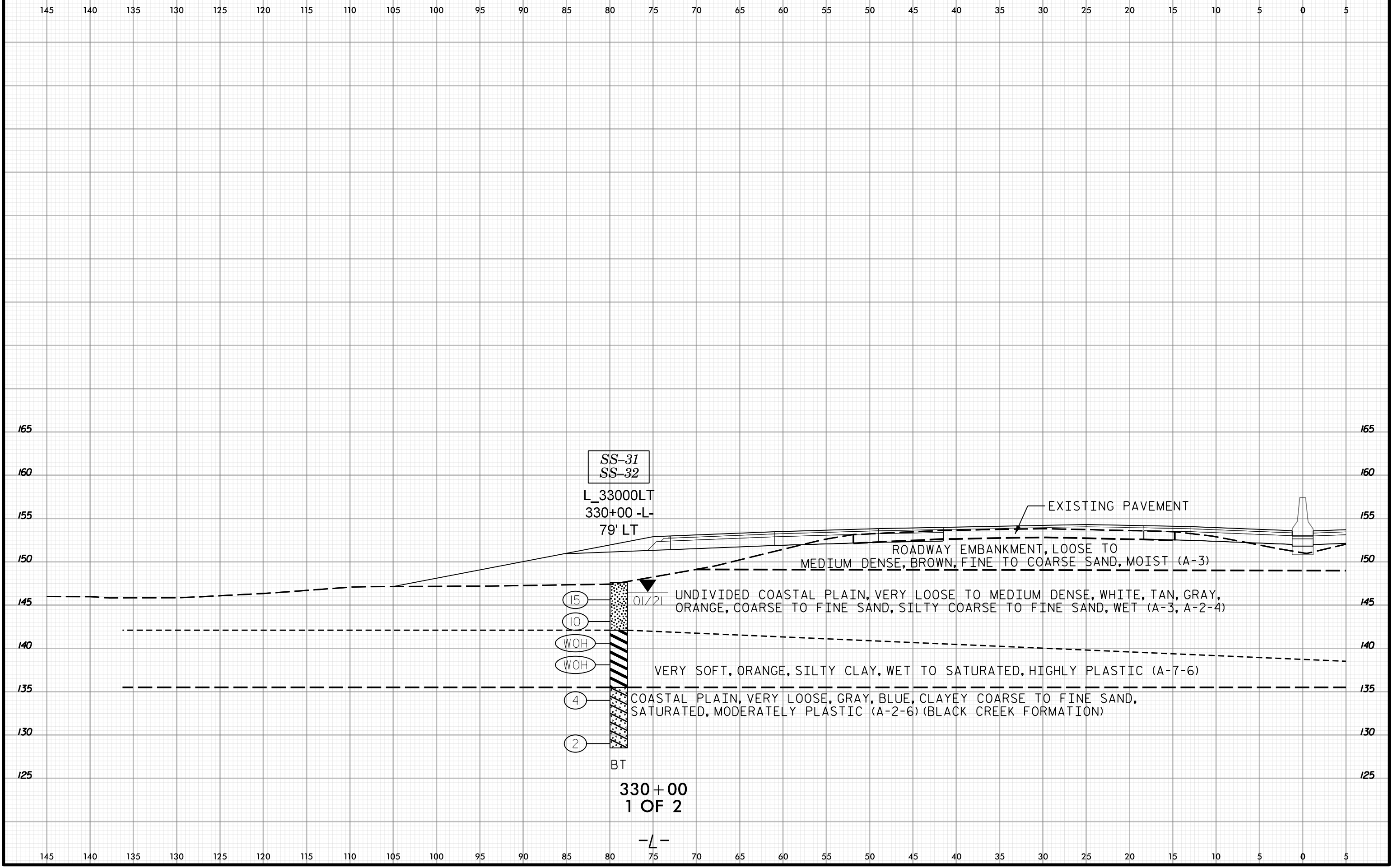

SS-31
SS-32
L_33000LT
330+00 -L-
79' LT

EXISTING PAVEMENT

ROADWAY EMBANKMENT, LOOSE TO MEDIUM DENSE, BROWN, FINE TO COARSE SAND, MOIST (A-3)

UNDIVIDED COASTAL PLAIN, VERY LOOSE TO MEDIUM DENSE, WHITE, TAN, GRAY, ORANGE, COARSE TO FINE SAND, SILTY COARSE TO FINE SAND, WET (A-3, A-2-4)

VERY SOFT, ORANGE, SILTY CLAY, WET TO SATURATED, HIGHLY PLASTIC (A-7-6)

COASTAL PLAIN, VERY LOOSE, GRAY, BLUE, CLAYEY COARSE TO FINE SAND, SATURATED, MODERATELY PLASTIC (A-2-6) (BLACK CREEK FORMATION)

- 15
- 10
- WOH
- WOH
- 4
- 2

BT

330+00
1 OF 2

-L-



5 0 5 10 15 20 25 30 35 40 45 50 55 60 65 70 75 80 85 90 95 100 105 110 115 120 125 130 135 140 145

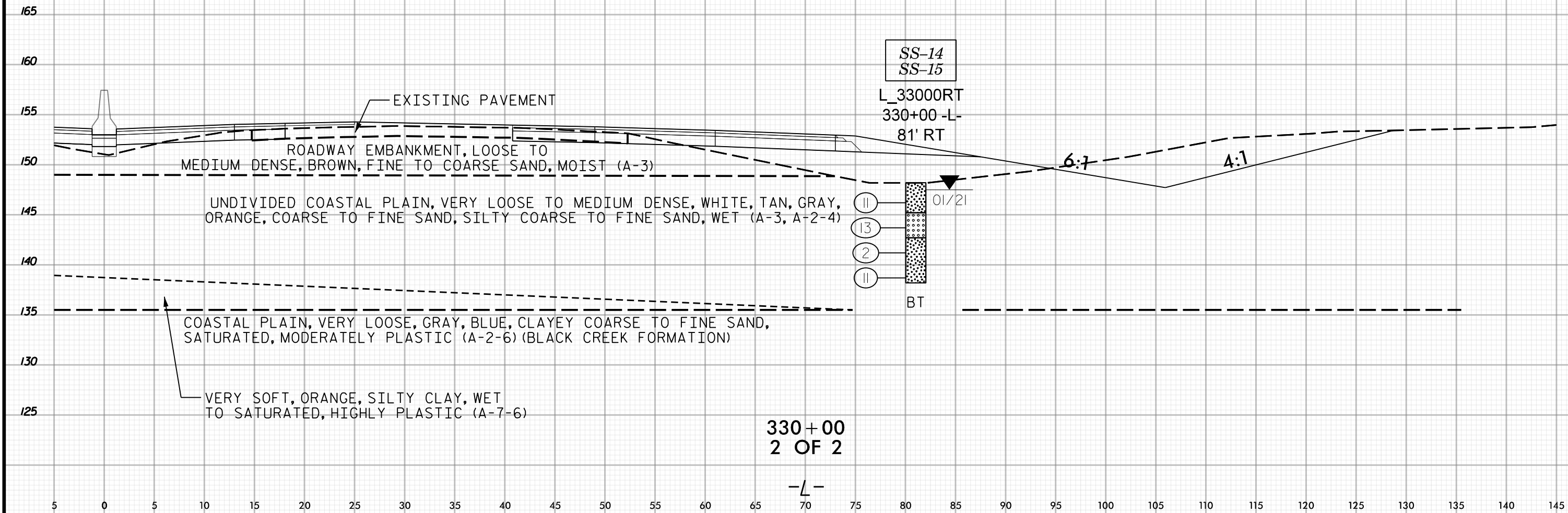

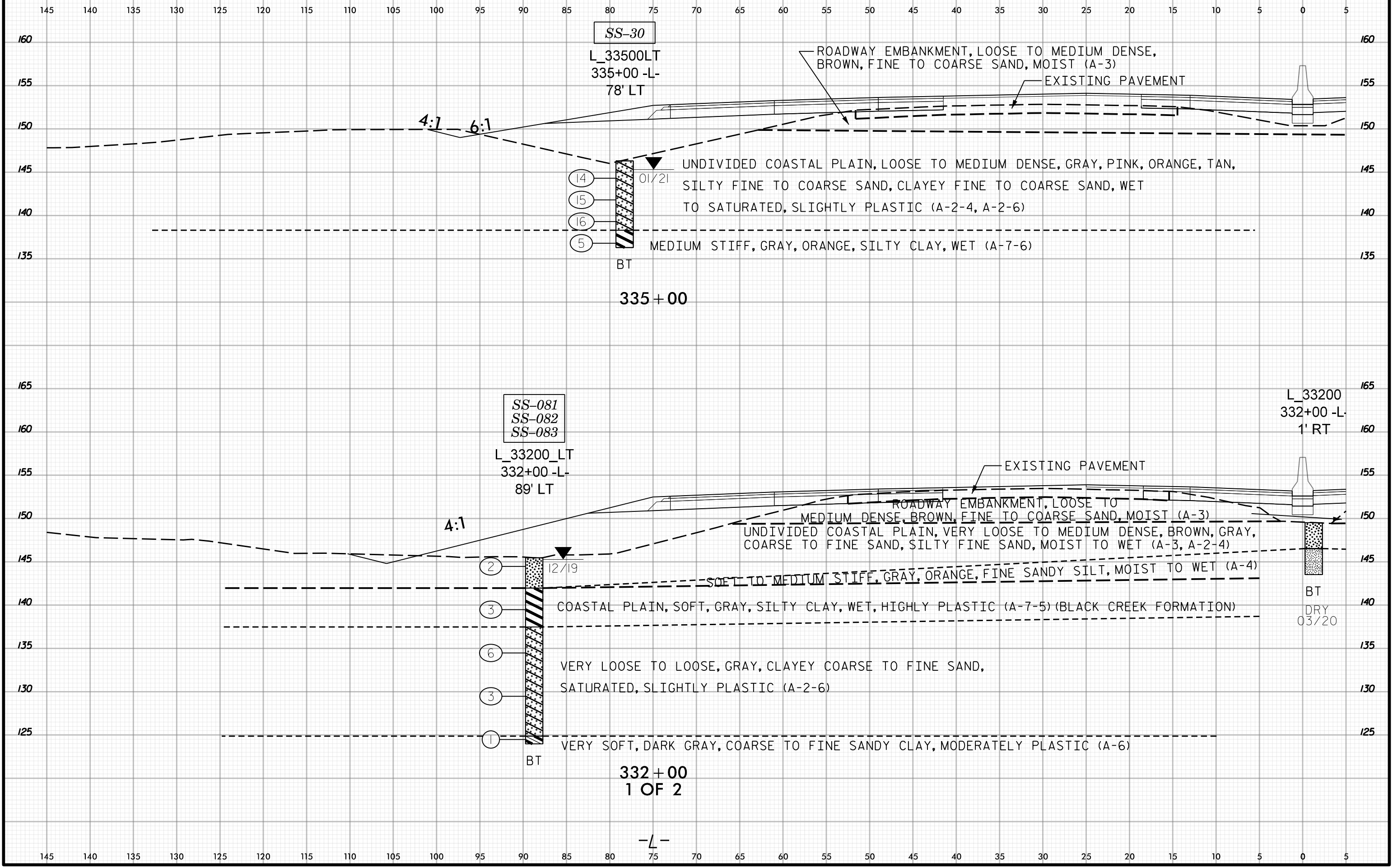

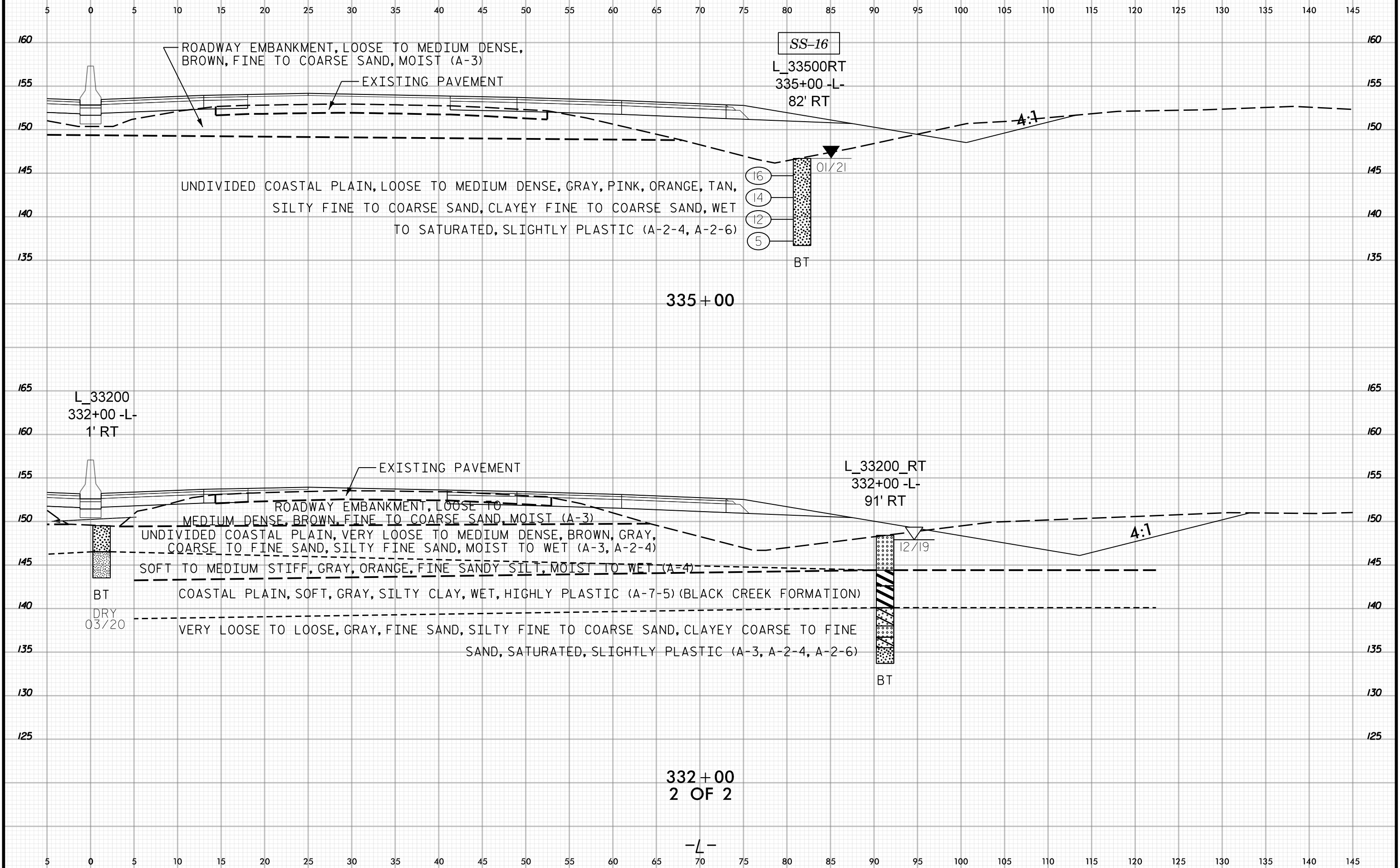
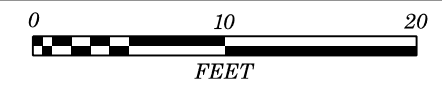

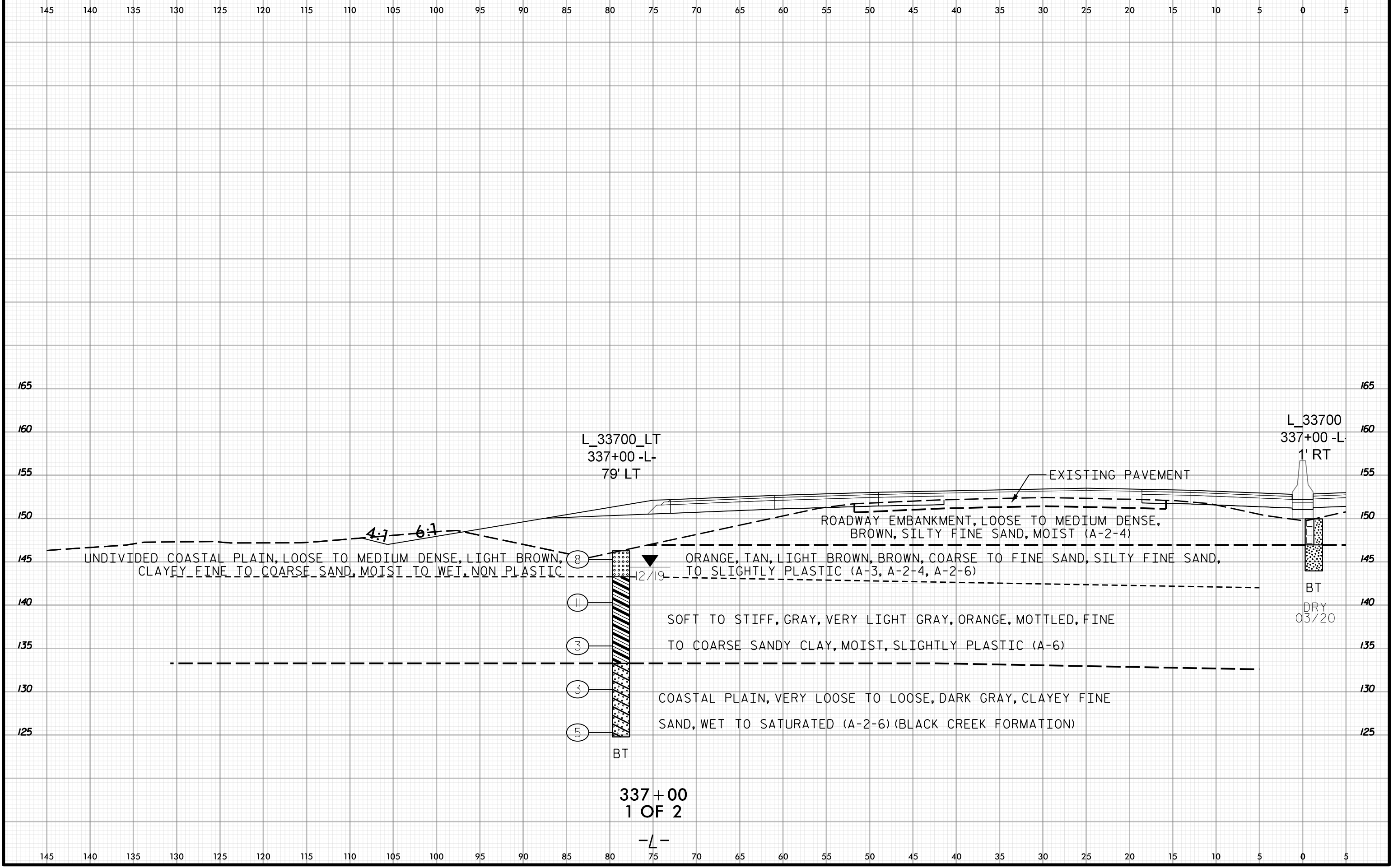
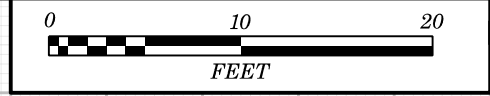



5 0 5 10 15 20 25 30 35 40 45 50 55 60 65 70 75 80 85 90 95 100 105 110 115 120 125 130 135 140 145

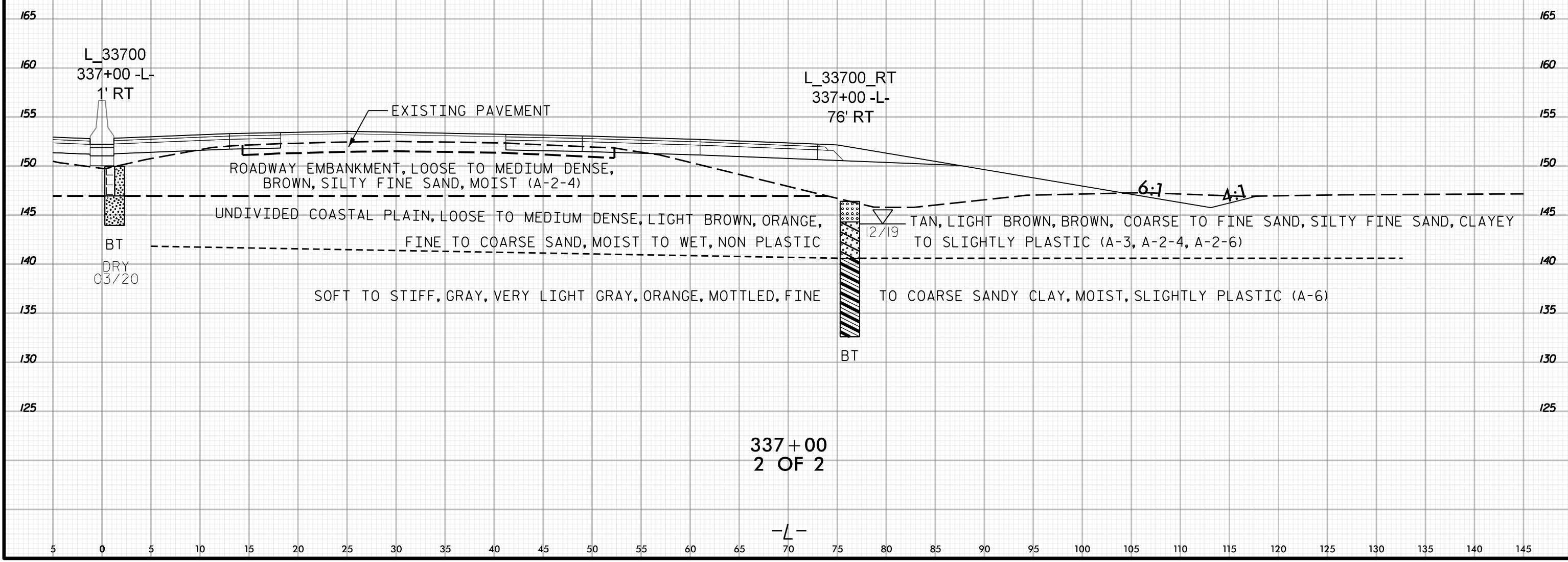



PROJ. REFERENCE NO.	SHEET NO.
I-5987A	572

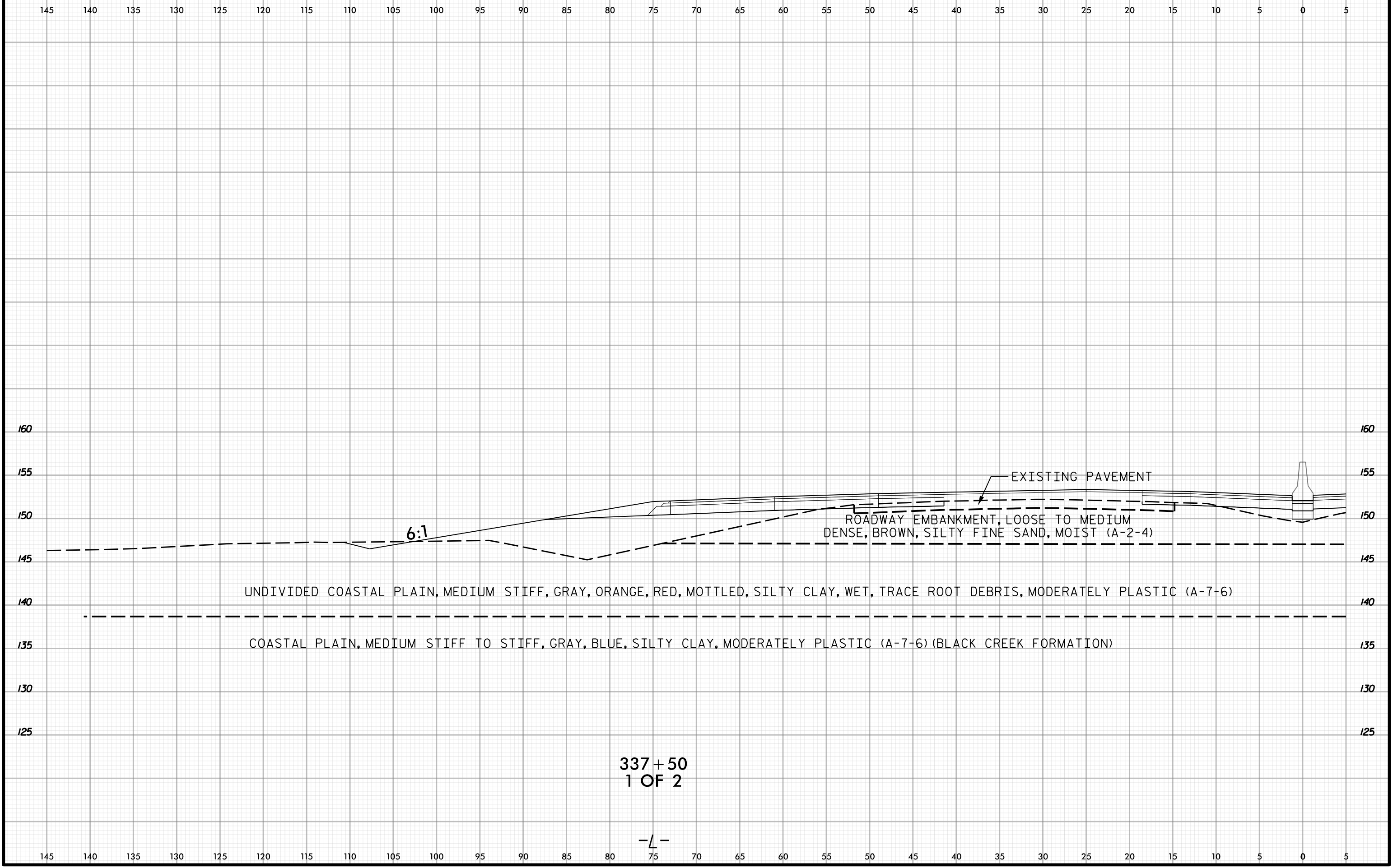



PROJ. REFERENCE NO.	SHEET NO.
I-5987A	573

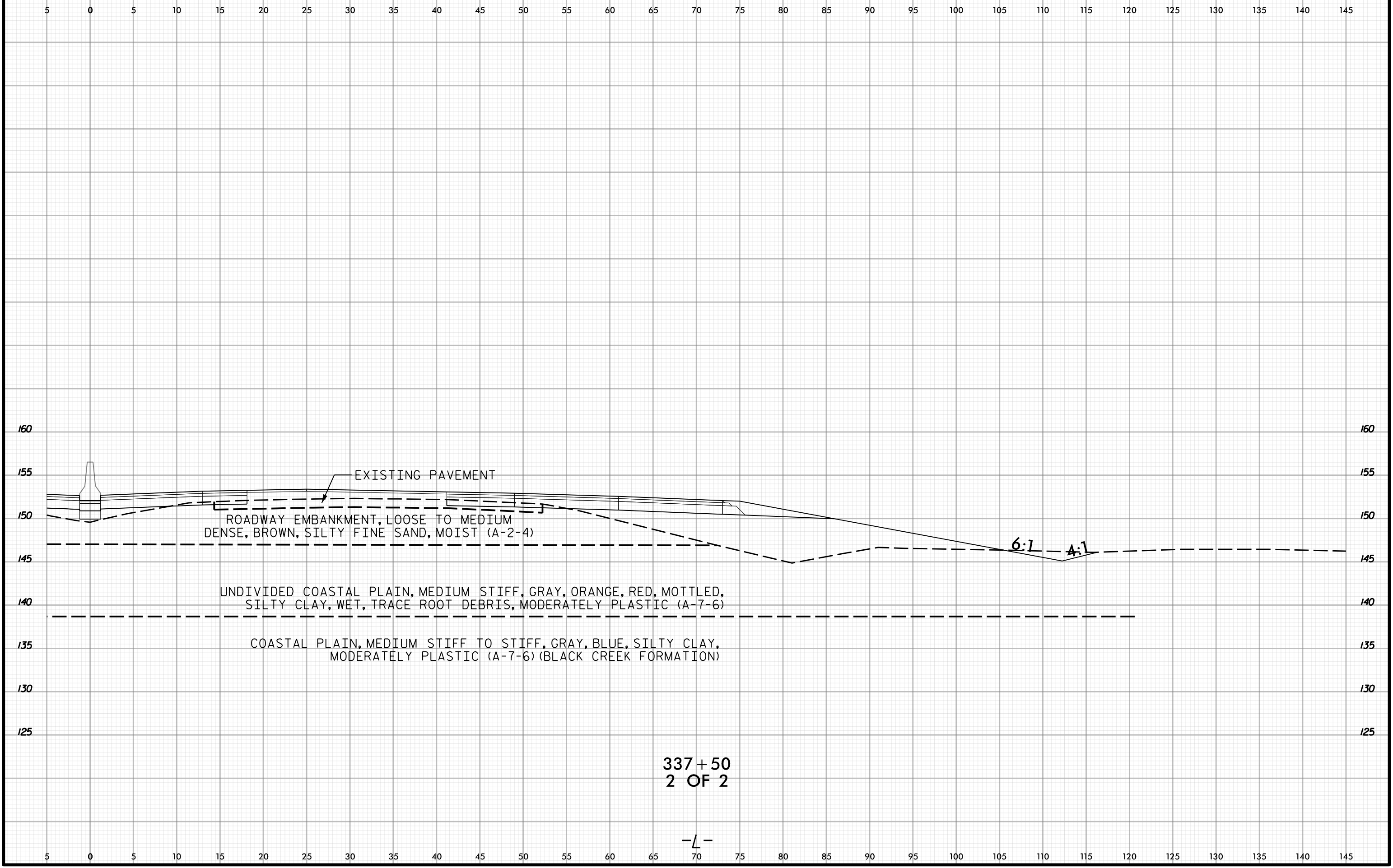

337+50
2 OF 2

-L-



PROJ. REFERENCE NO.	SHEET NO.
I-5987A	574

145 140 135 130 125 120 115 110 105 100 95 90 85 80 75 70 65 60 55 50 45 40 35 30 25 20 15 10 5 0 5

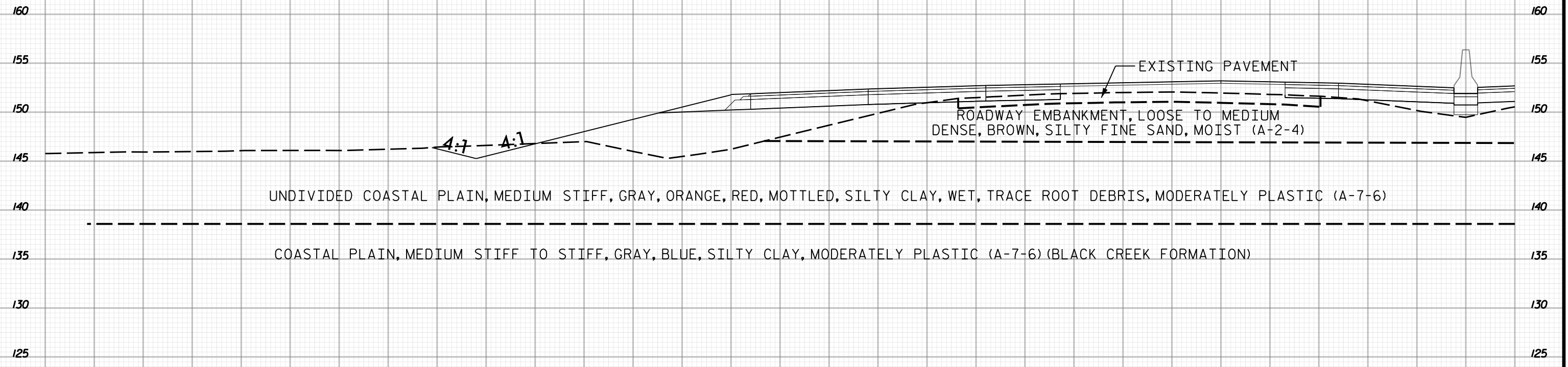

338+00
1 OF 2

-L-

145 140 135 130 125 120 115 110 105 100 95 90 85 80 75 70 65 60 55 50 45 40 35 30 25 20 15 10 5 0 5



PROJ. REFERENCE NO.	SHEET NO.
I-5987A	575

5 0 5 10 15 20 25 30 35 40 45 50 55 60 65 70 75 80 85 90 95 100 105 110 115 120 125 130 135 140 145

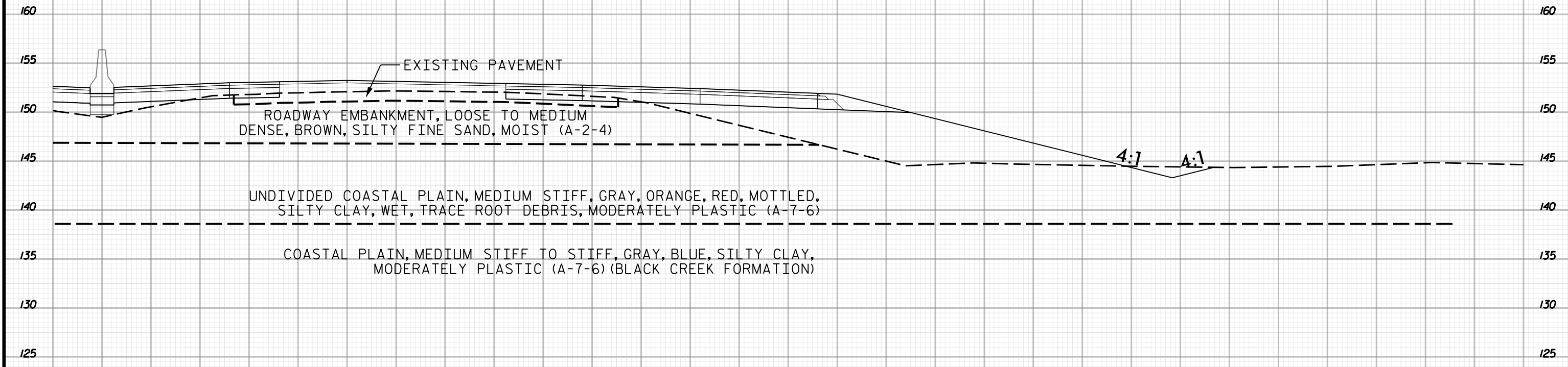

338+00
2 OF 2

-L-

5 0 5 10 15 20 25 30 35 40 45 50 55 60 65 70 75 80 85 90 95 100 105 110 115 120 125 130 135 140 145



145 140 135 130 125 120 115 110 105 100 95 90 85 80 75 70 65 60 55 50 45 40 35 30 25 20 15 10 5 0 5

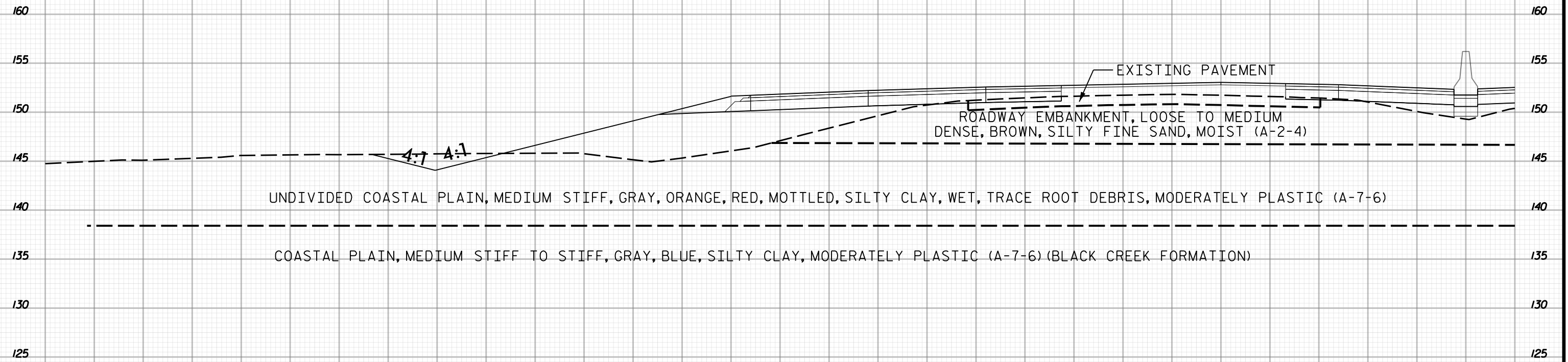

338 + 50
1 OF 2

-L-

145 140 135 130 125 120 115 110 105 100 95 90 85 80 75 70 65 60 55 50 45 40 35 30 25 20 15 10 5 0 5



PROJ. REFERENCE NO.	SHEET NO.
I-5987A	577

5 0 5 10 15 20 25 30 35 40 45 50 55 60 65 70 75 80 85 90 95 100 105 110 115 120 125 130 135 140 145

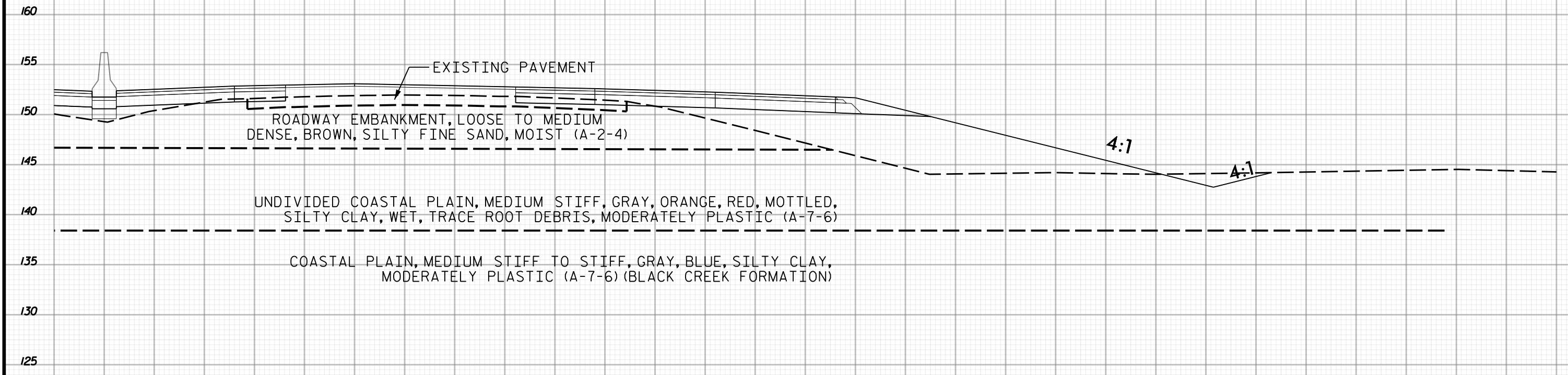

338+50
2 OF 2

-L-

5 0 5 10 15 20 25 30 35 40 45 50 55 60 65 70 75 80 85 90 95 100 105 110 115 120 125 130 135 140 145

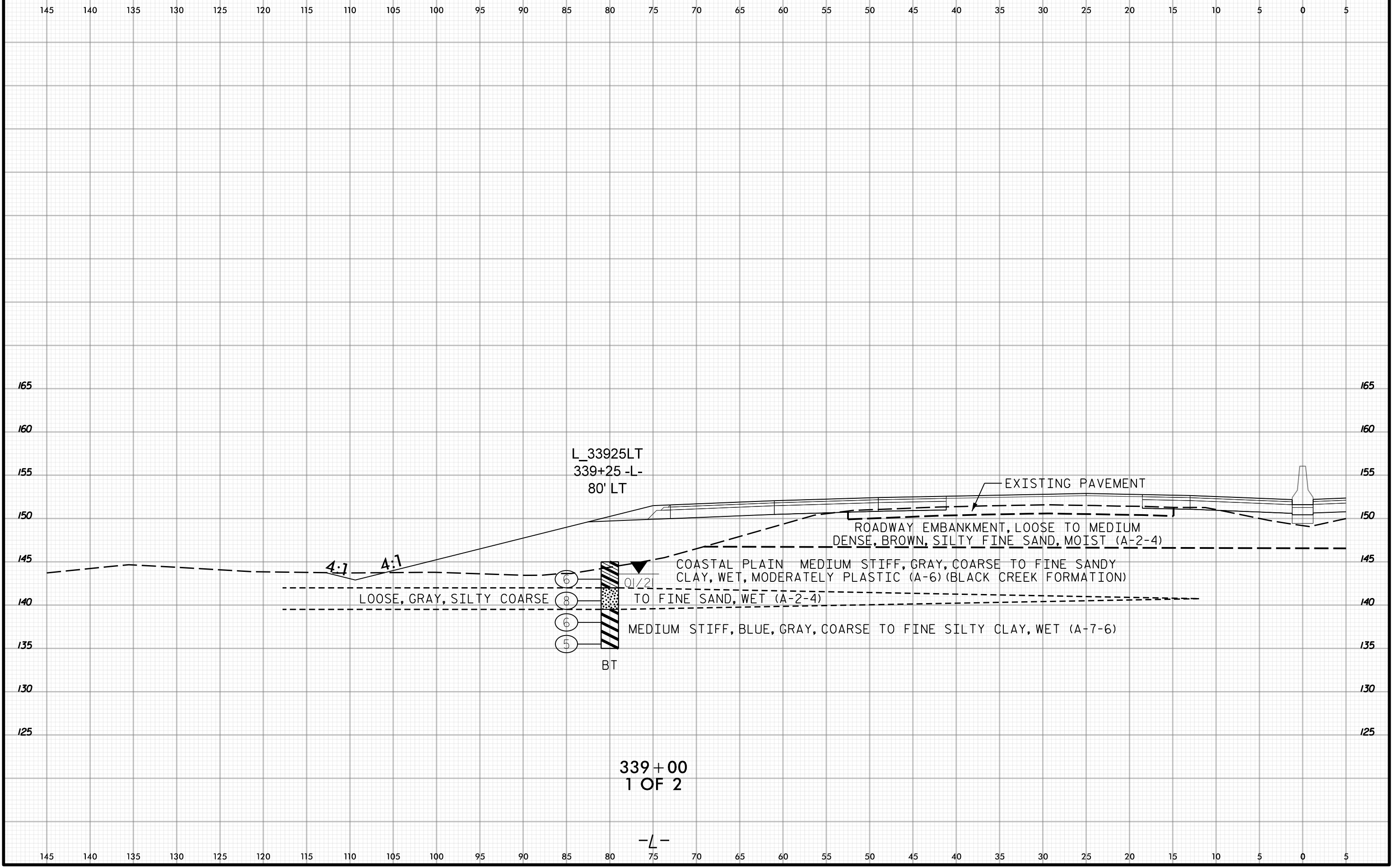
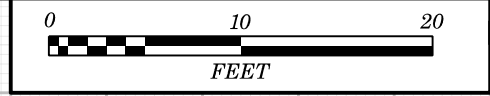

L_33925LT
339+25 -L-
80' LT

EXISTING PAVEMENT

ROADWAY EMBANKMENT, LOOSE TO MEDIUM
DENSE, BROWN, SILTY FINE SAND, MOIST (A-2-4)

COASTAL PLAIN MEDIUM STIFF, GRAY, COARSE TO FINE SANDY
CLAY, WET, MODERATELY PLASTIC (A-6) (BLACK CREEK FORMATION)

LOOSE, GRAY, SILTY COARSE

TO FINE SAND, WET (A-2-4)

MEDIUM STIFF, BLUE, GRAY, COARSE TO FINE SILTY CLAY, WET (A-7-6)

BT

339+00
1 OF 2

-L-



5 0 5 10 15 20 25 30 35 40 45 50 55 60 65 70 75 80 85 90 95 100 105 110 115 120 125 130 135 140 145

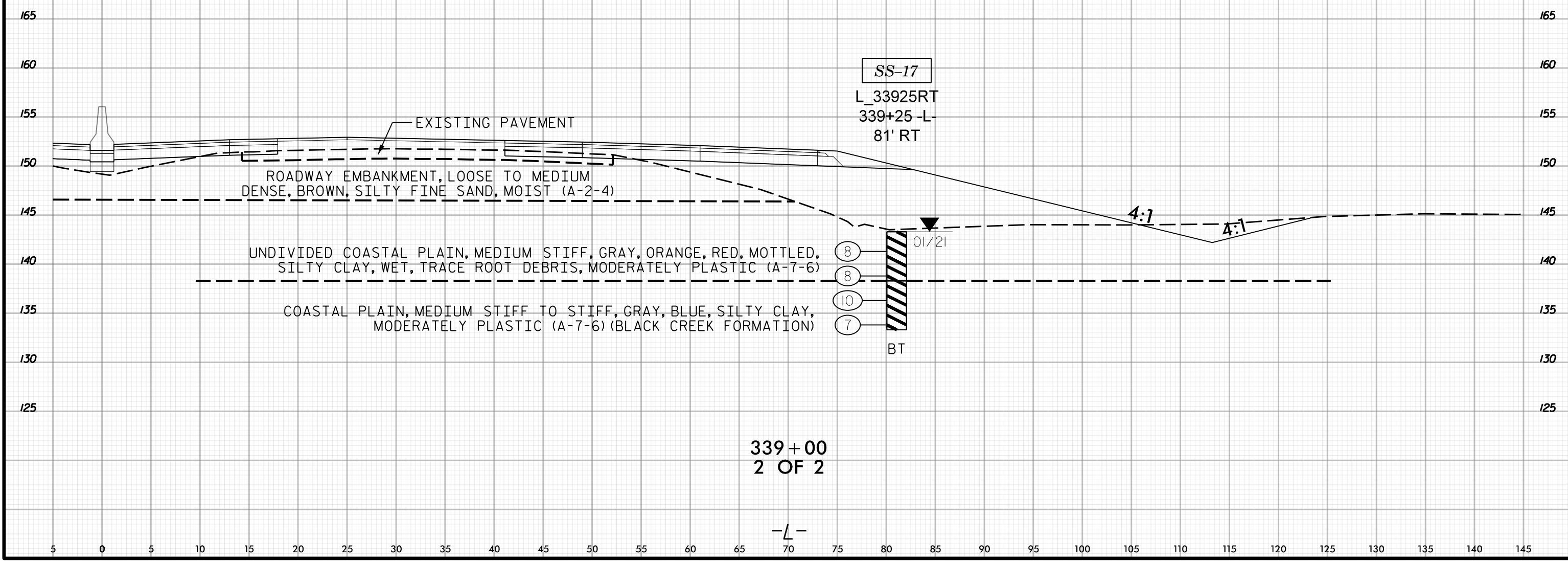

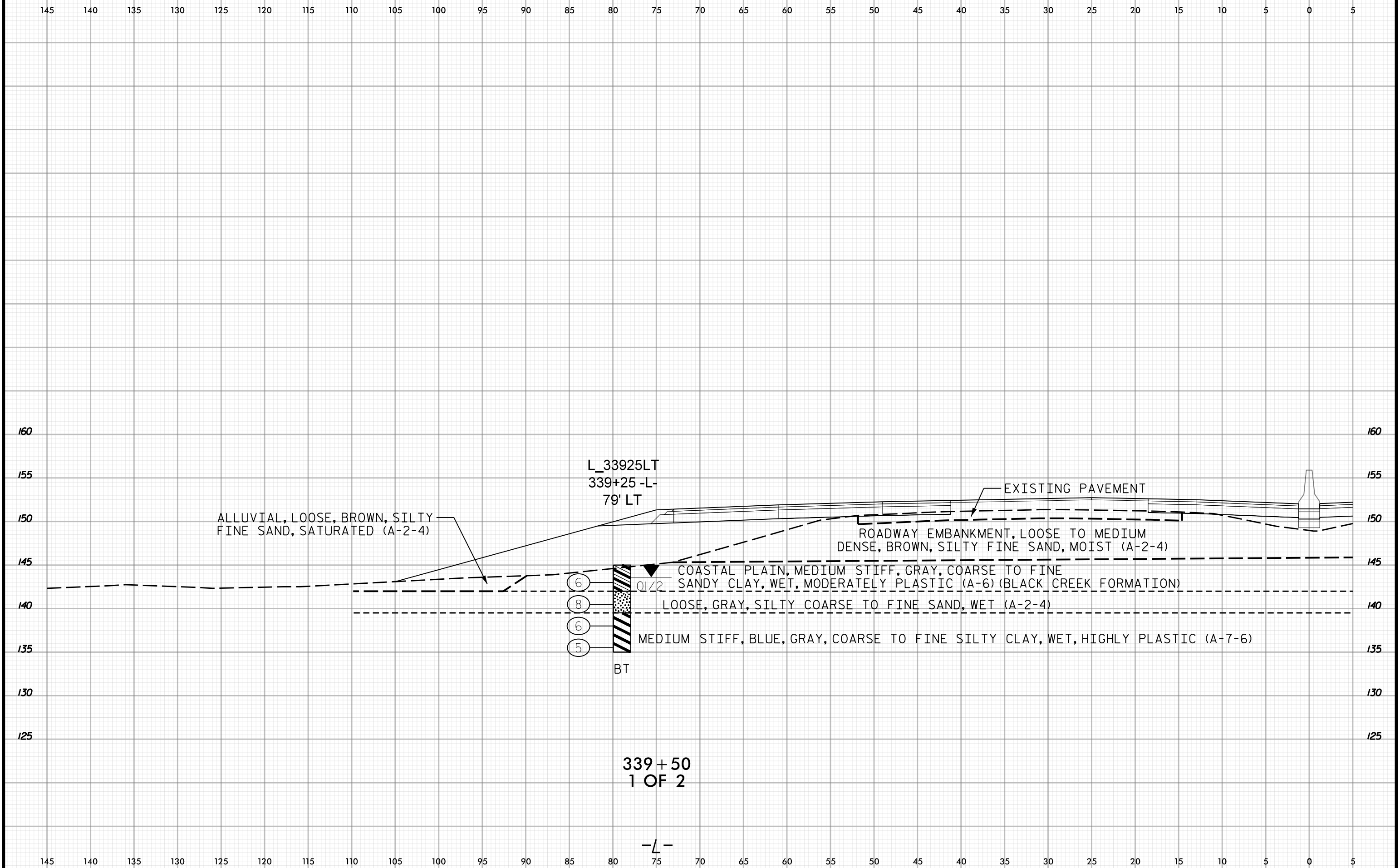

L_33925LT
339+25 -L-
79' LT

ALLUVIAL, LOOSE, BROWN, SILTY
FINE SAND, SATURATED (A-2-4)

EXISTING PAVEMENT

ROADWAY EMBANKMENT, LOOSE TO MEDIUM
DENSE, BROWN, SILTY FINE SAND, MOIST (A-2-4)

COASTAL PLAIN, MEDIUM STIFF, GRAY, COARSE TO FINE
SANDY CLAY, WET, MODERATELY PLASTIC (A-6) (BLACK CREEK FORMATION)

LOOSE, GRAY, SILTY COARSE TO FINE SAND, WET (A-2-4)

MEDIUM STIFF, BLUE, GRAY, COARSE TO FINE SILTY CLAY, WET, HIGHLY PLASTIC (A-7-6)

BT

339 + 50
1 OF 2

-L-

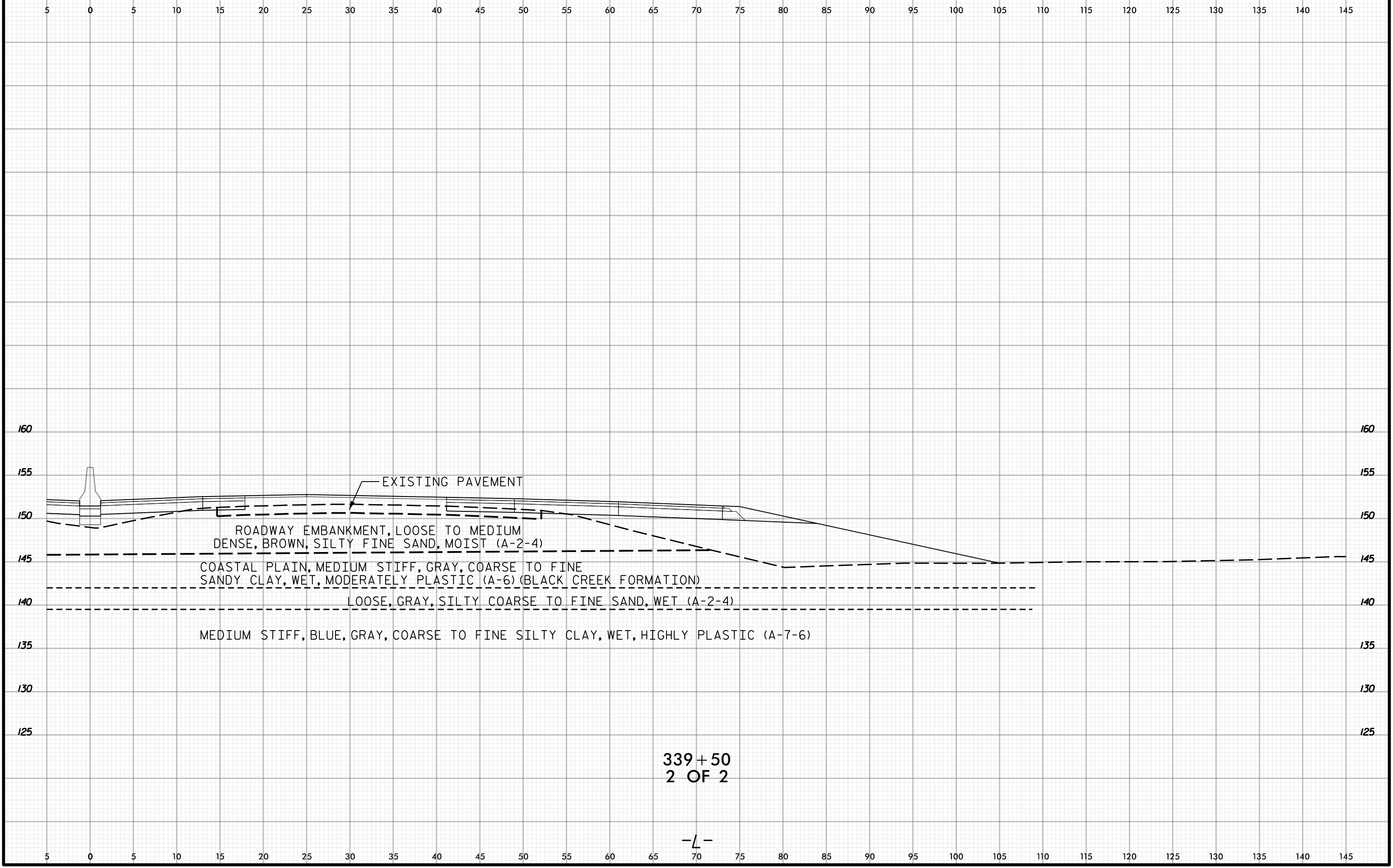

EXISTING PAVEMENT

ROADWAY EMBANKMENT, LOOSE TO MEDIUM
DENSE, BROWN, SILTY FINE SAND, MOIST (A-2-4)

COASTAL PLAIN, MEDIUM STIFF, GRAY, COARSE TO FINE
SANDY CLAY, WET, MODERATELY PLASTIC (A-6) (BLACK CREEK FORMATION)

LOOSE, GRAY, SILTY COARSE TO FINE SAND, WET (A-2-4)

MEDIUM STIFF, BLUE, GRAY, COARSE TO FINE SILTY CLAY, WET, HIGHLY PLASTIC (A-7-6)

339+50
2 OF 2

-L-



145 140 135 130 125 120 115 110 105 100 95 90 85 80 75 70 65 60 55 50 45 40 35 30 25 20 15 10 5 0 5

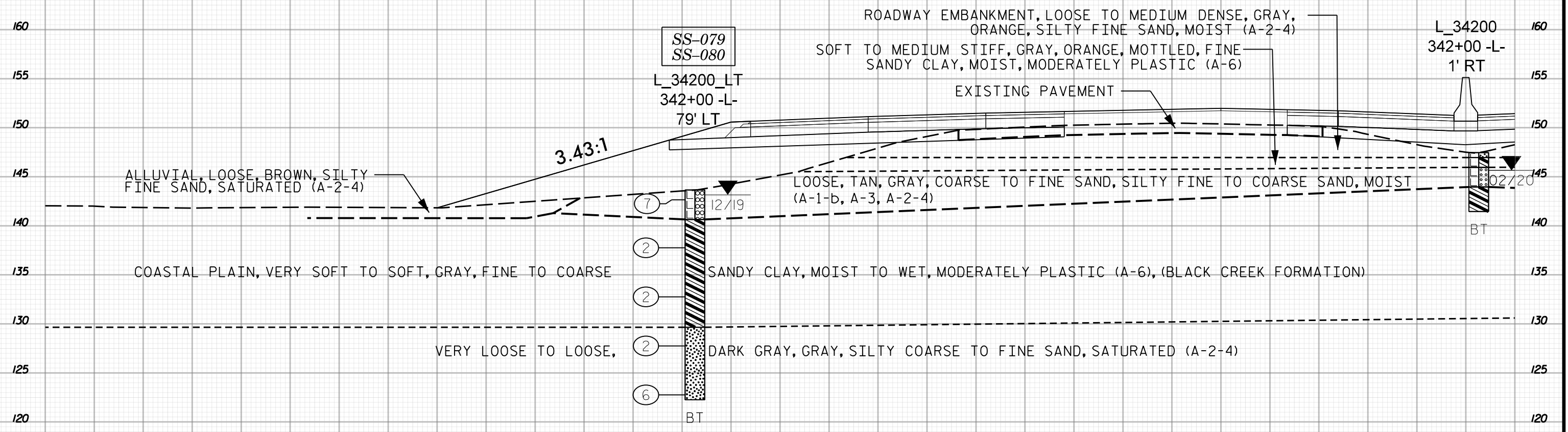

342 + 00
1 OF 2

145 140 135 130 125 120 115 110 105 100 95 90 85 80 75 70 65 60 55 50 45 40 35 30 25 20 15 10 5 0 5



5 0 5 10 15 20 25 30 35 40 45 50 55 60 65 70 75 80 85 90 95 100 105 110 115 120 125 130 135 140 145

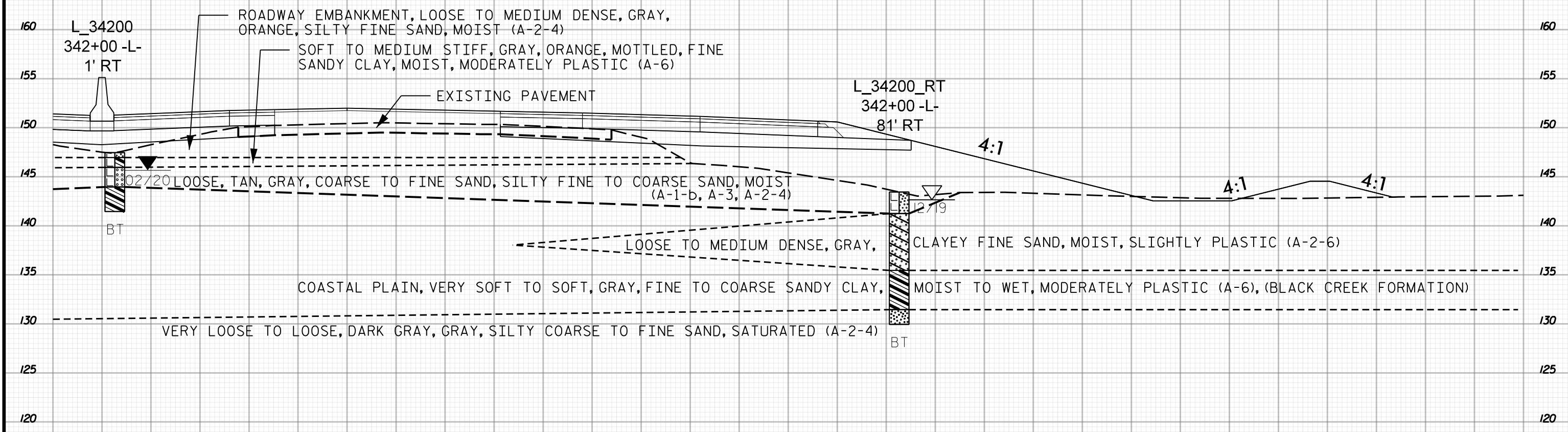

342+00
2 OF 2

-L-

5 0 5 10 15 20 25 30 35 40 45 50 55 60 65 70 75 80 85 90 95 100 105 110 115 120 125 130 135 140 145

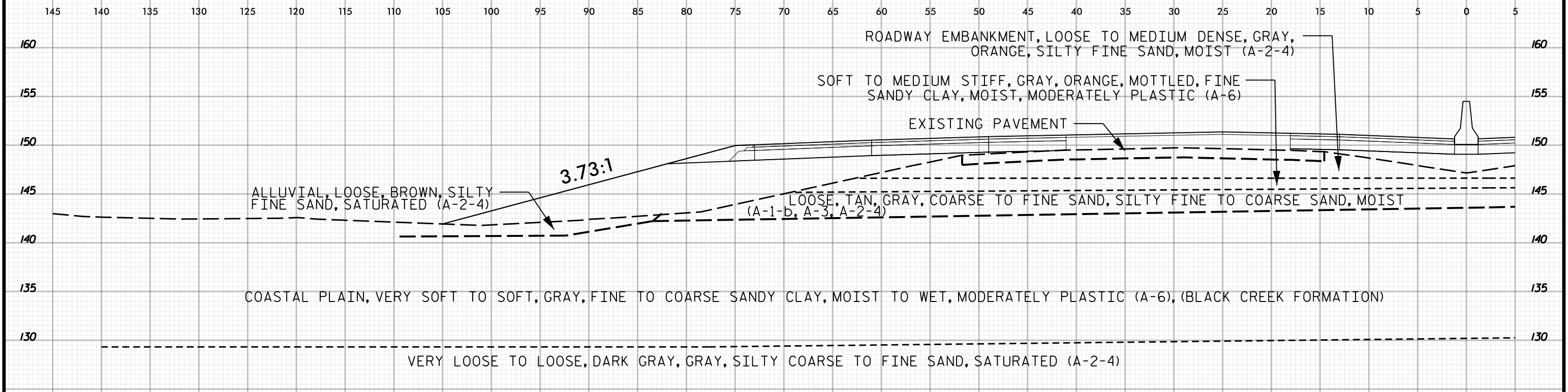
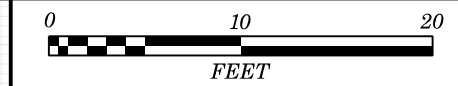

344+00

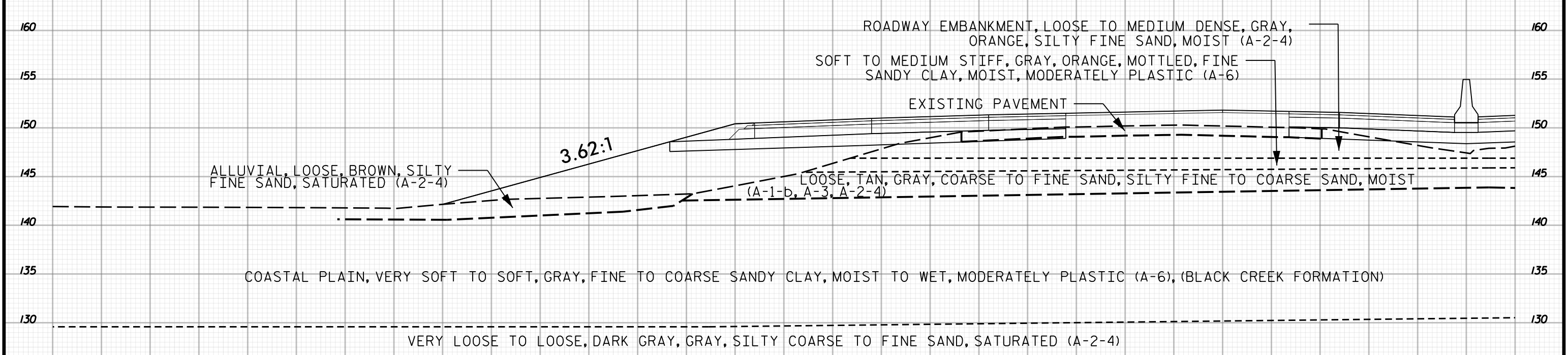

342+50
1 OF 2

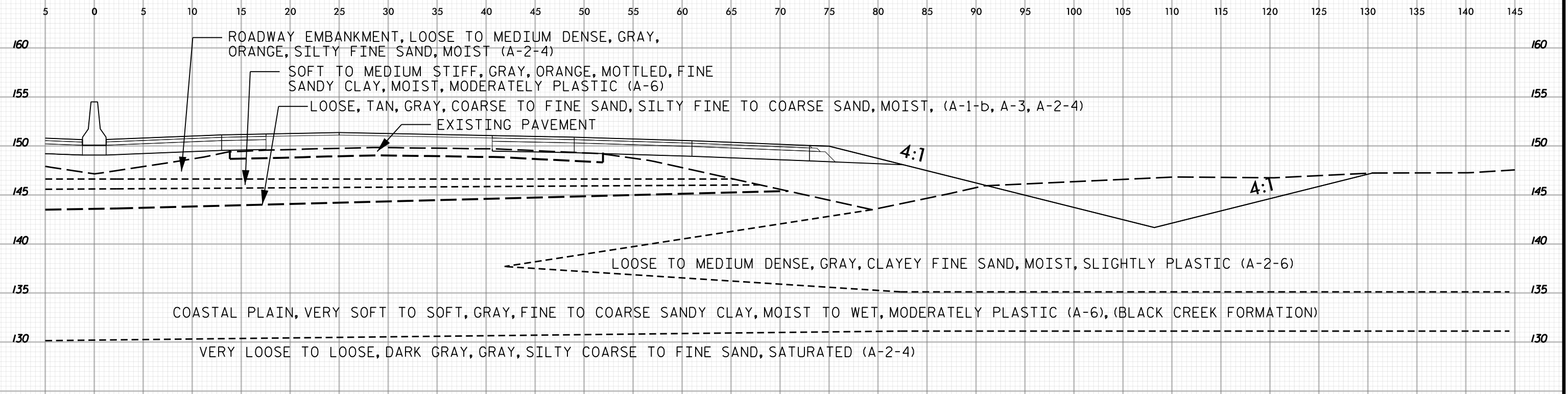
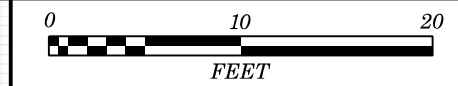

344+00

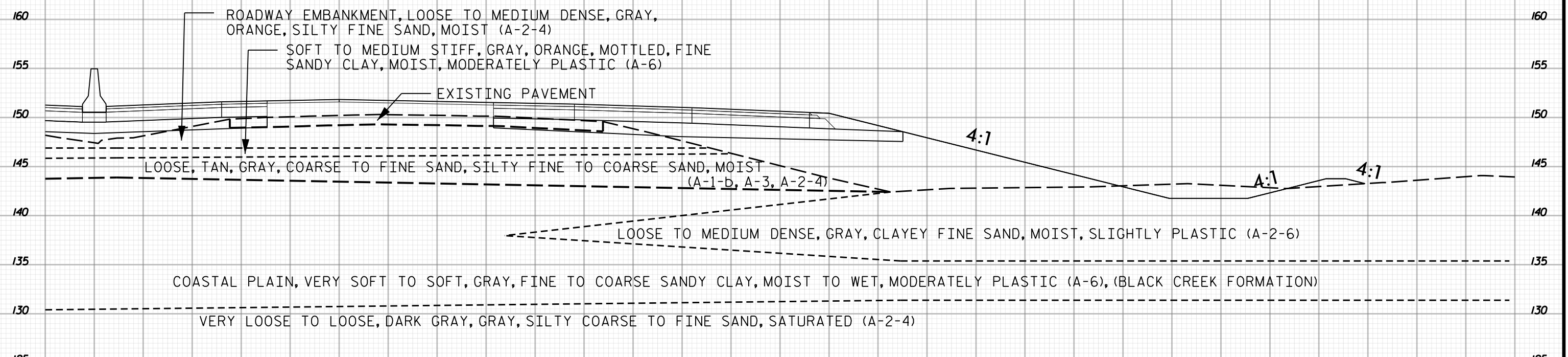

342+50
2 OF 2

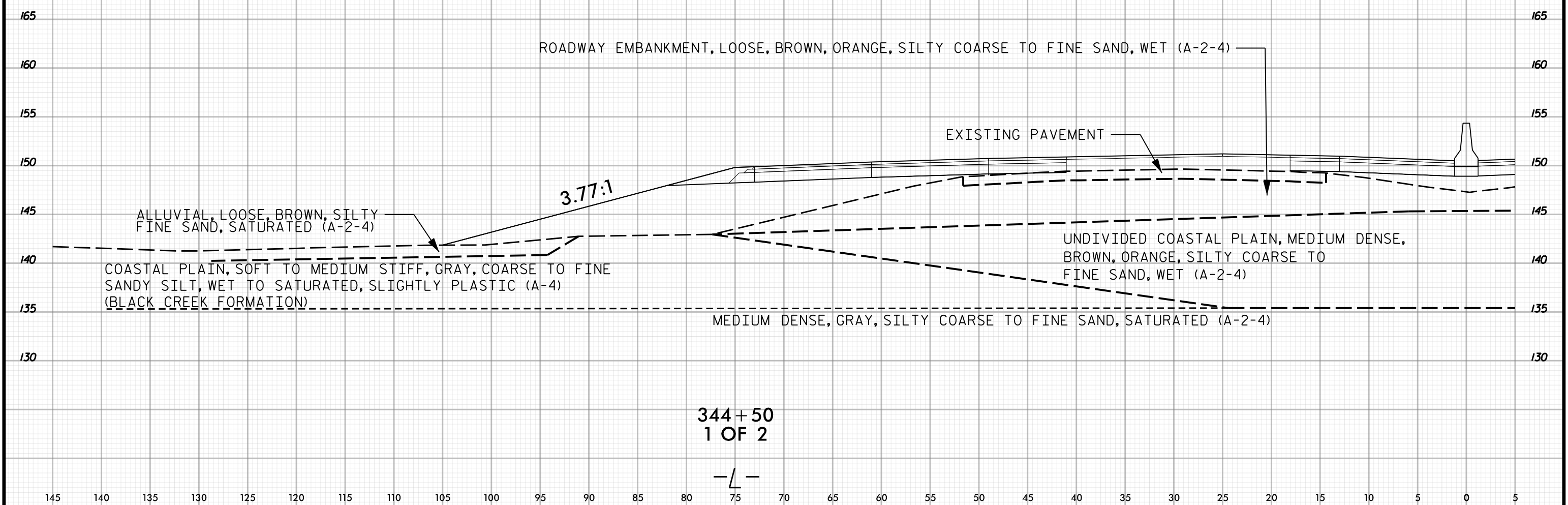
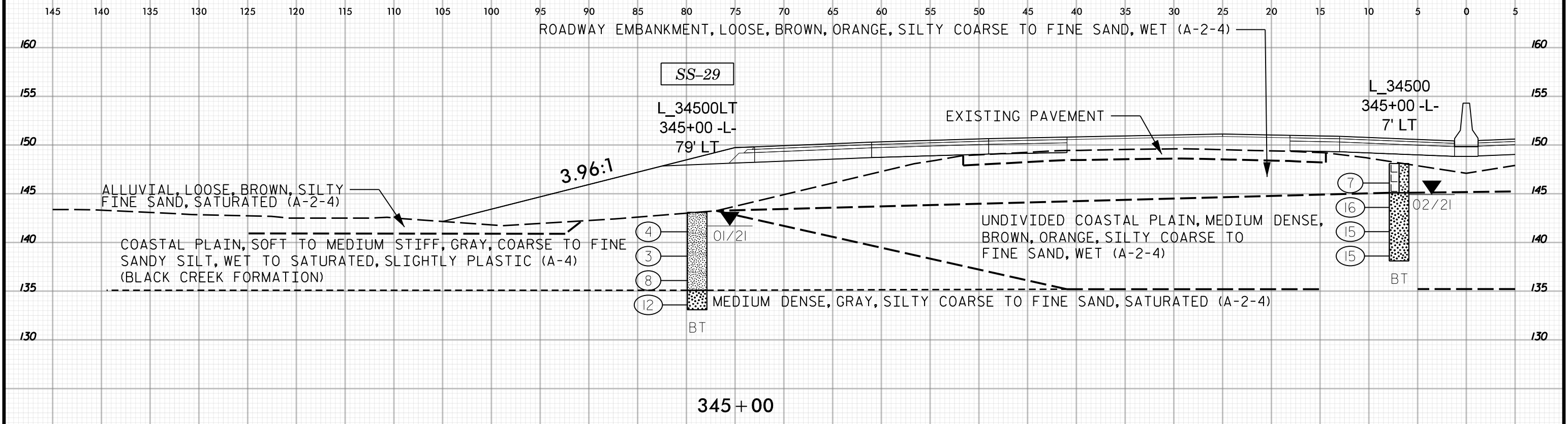
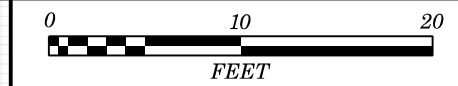

344+50
1 OF 2

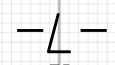

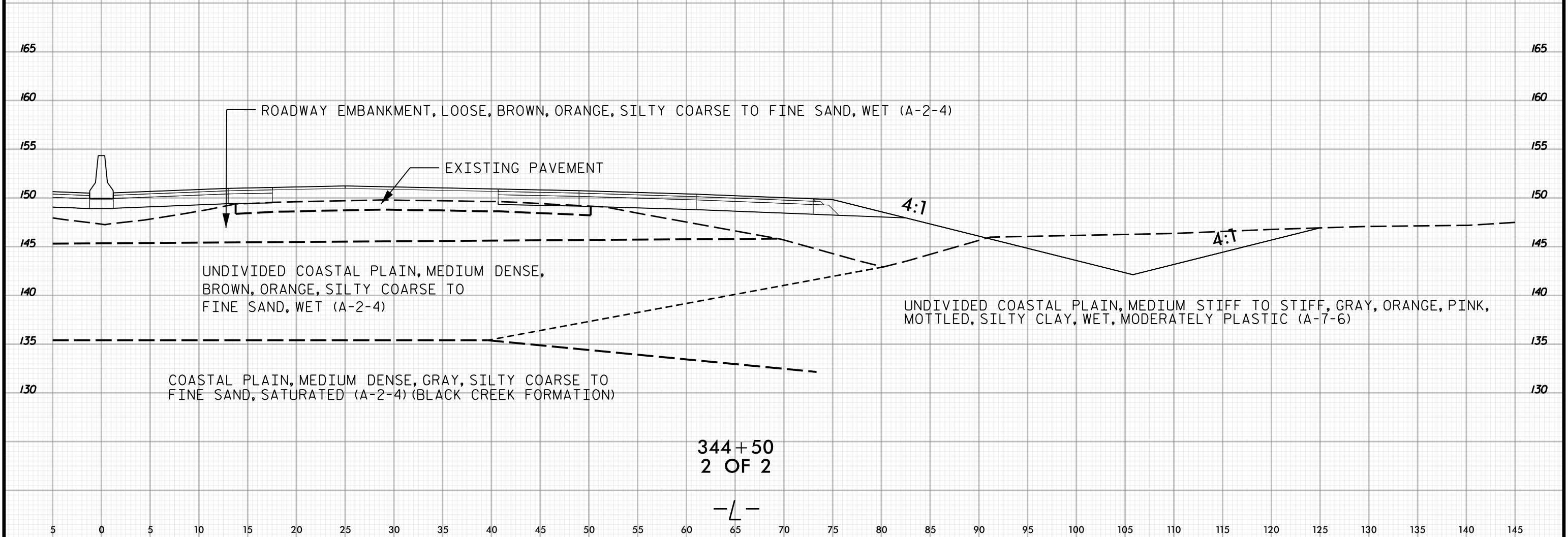
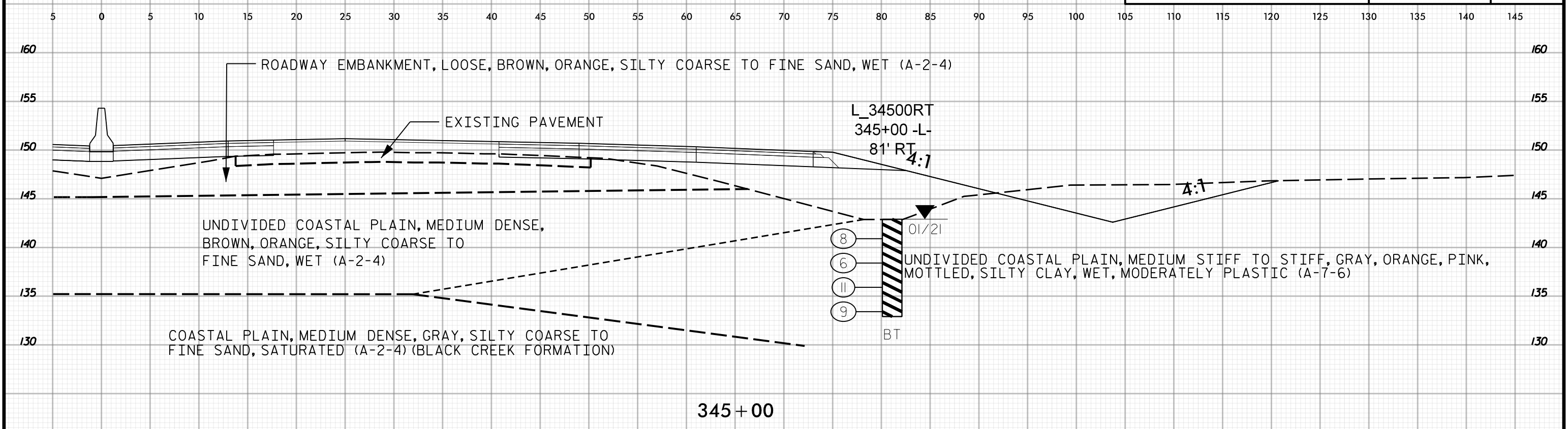



145 140 135 130 125 120 115 110 105 100 95 90 85 80 75 70 65 60 55 50 45 40 35 30 25 20 15 10 5 0 5

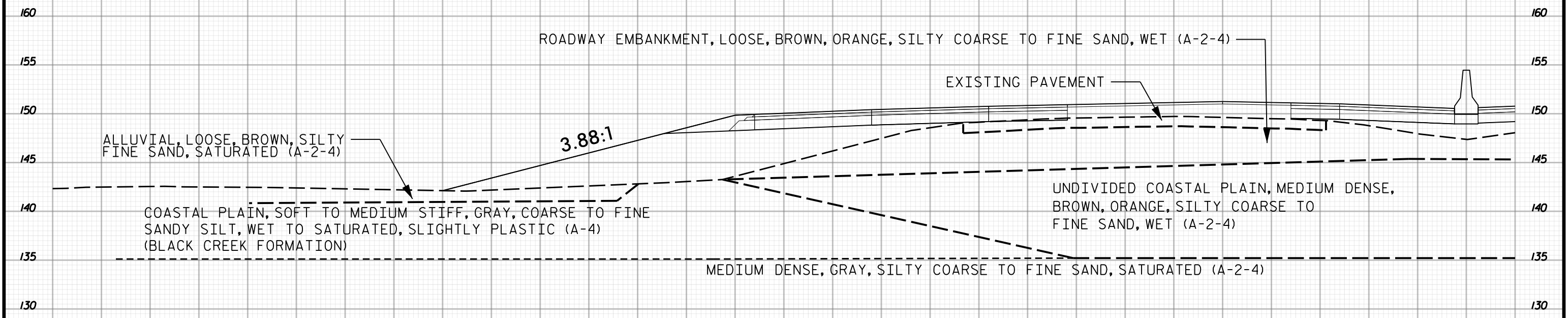

346+00

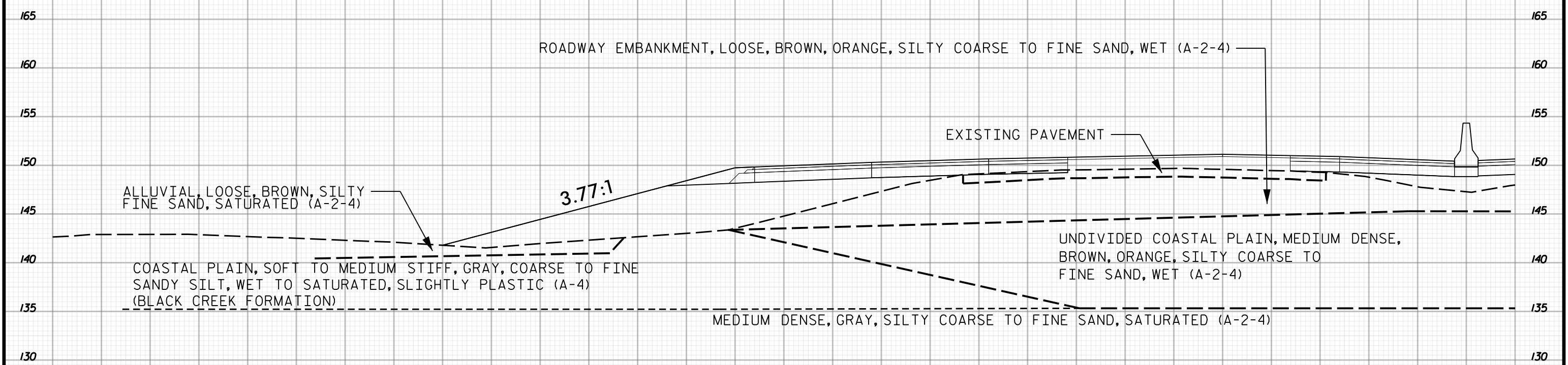

345+50
1 OF 2

145 140 135 130 125 120 115 110 105 100 95 90 85 80 75 70 65 60 55 50 45 40 35 30 25 20 15 10 5 0 5

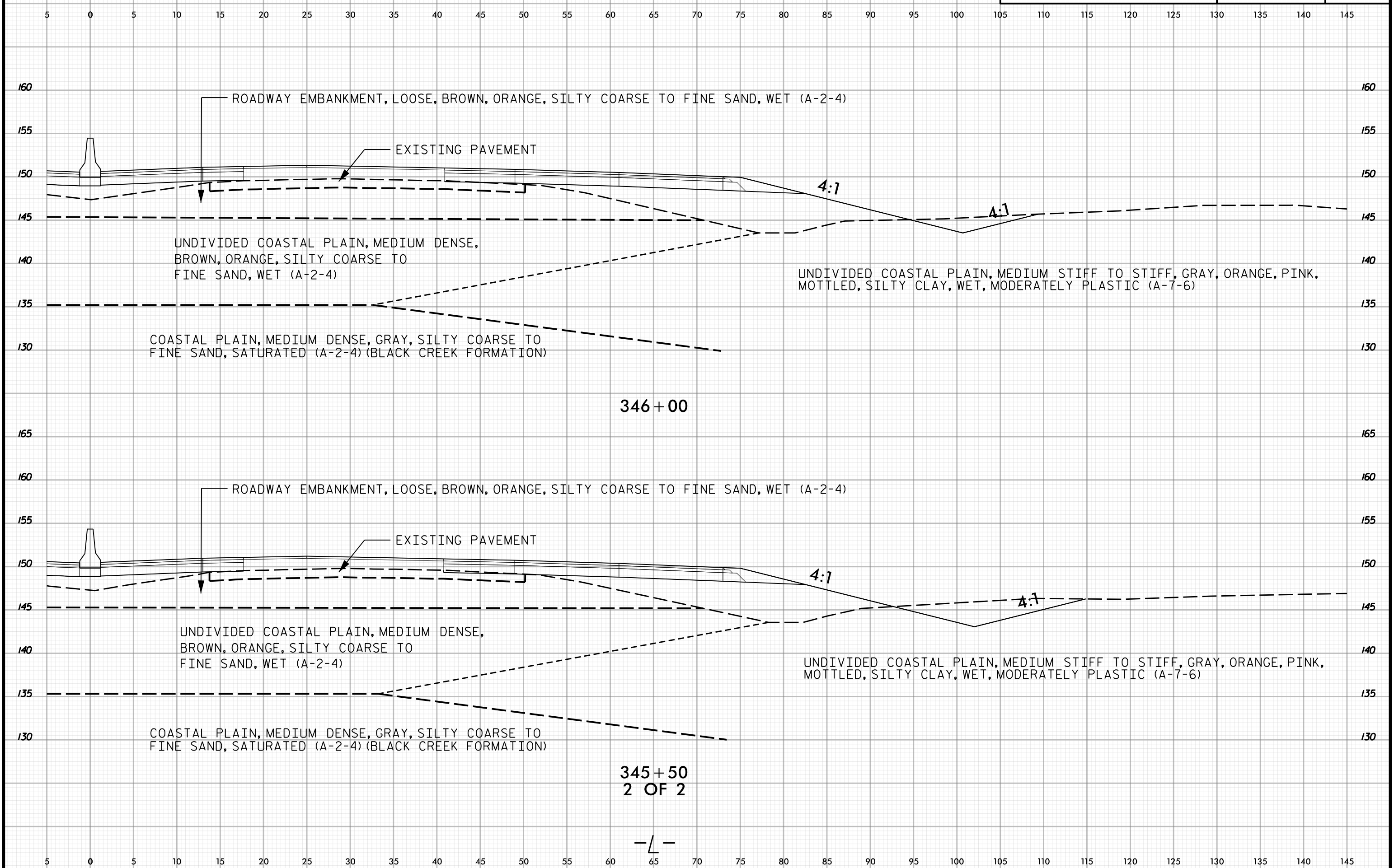
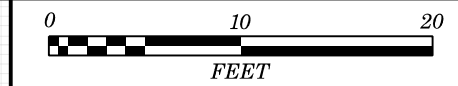



145 140 135 130 125 120 115 110 105 100 95 90 85 80 75 70 65 60 55 50 45 40 35 30 25 20 15 10 5 0 5

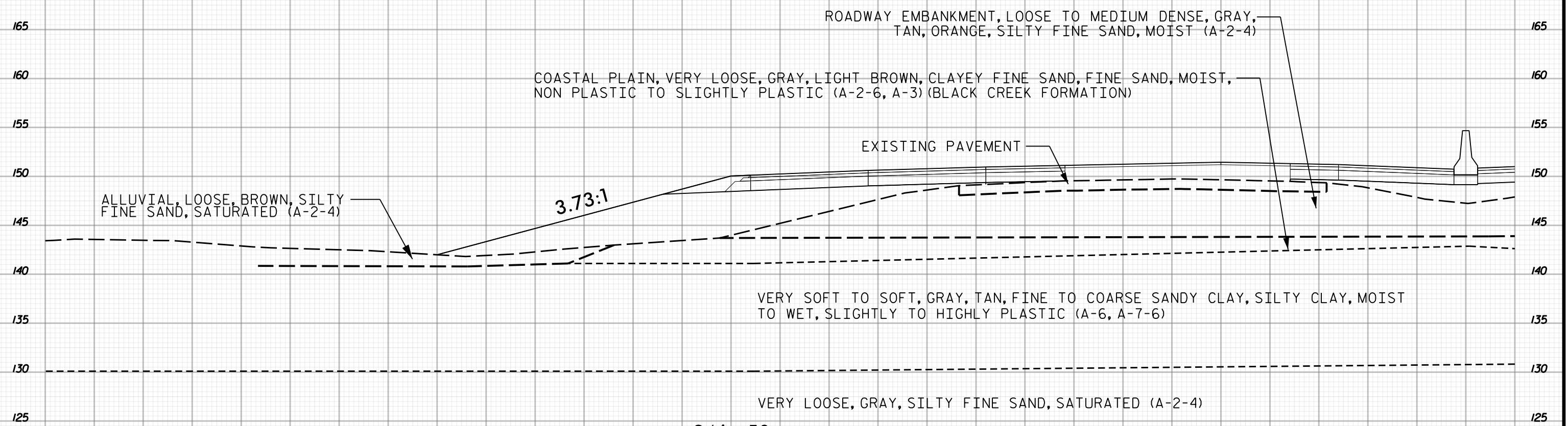

145 140 135 130 125 120 115 110 105 100 95 90 85 80 75 70 65 60 55 50 45 40 35 30 25 20 15 10 5 0 5

346 + 50
1 OF 2

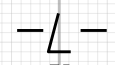



PROJ. REFERENCE NO.	SHEET NO.
I-5987A	591

5 0 5 10 15 20 25 30 35 40 45 50 55 60 65 70 75 80 85 90 95 100 105 110 115 120 125 130 135 140 145

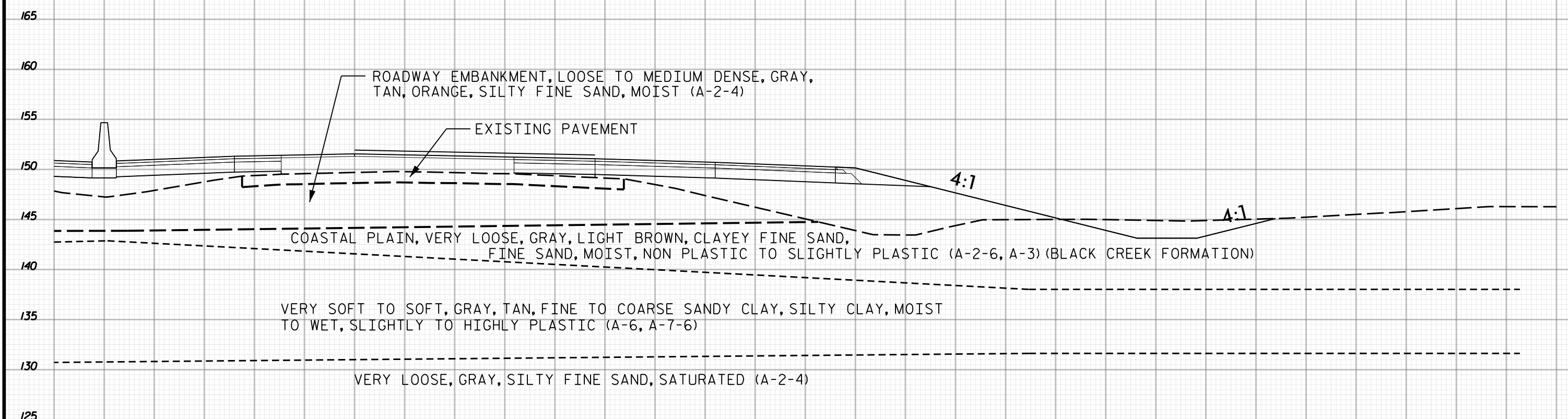

346+50
2 OF 2

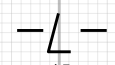

5 0 5 10 15 20 25 30 35 40 45 50 55 60 65 70 75 80 85 90 95 100 105 110 115 120 125 130 135 140 145

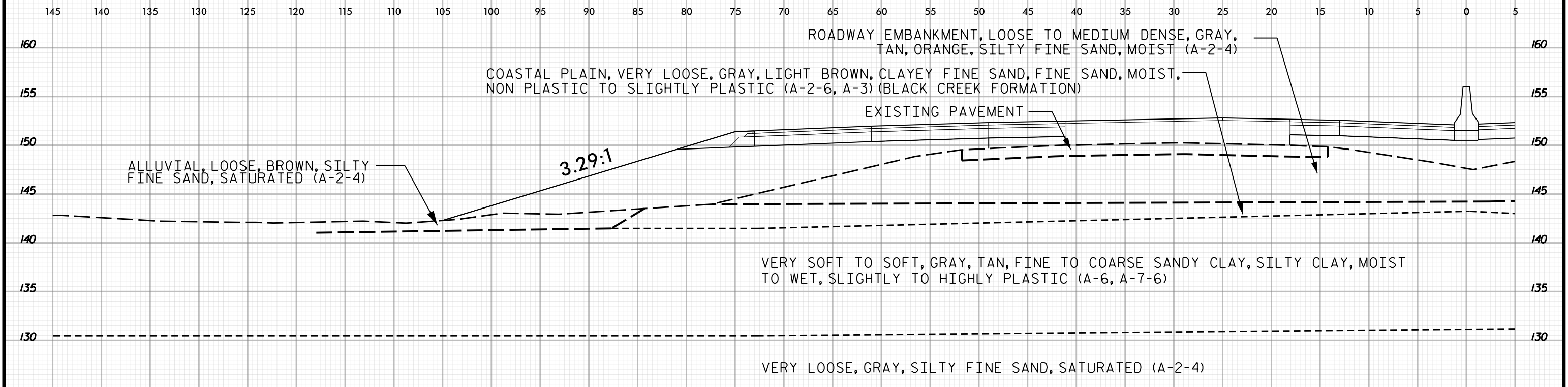

349 + 00

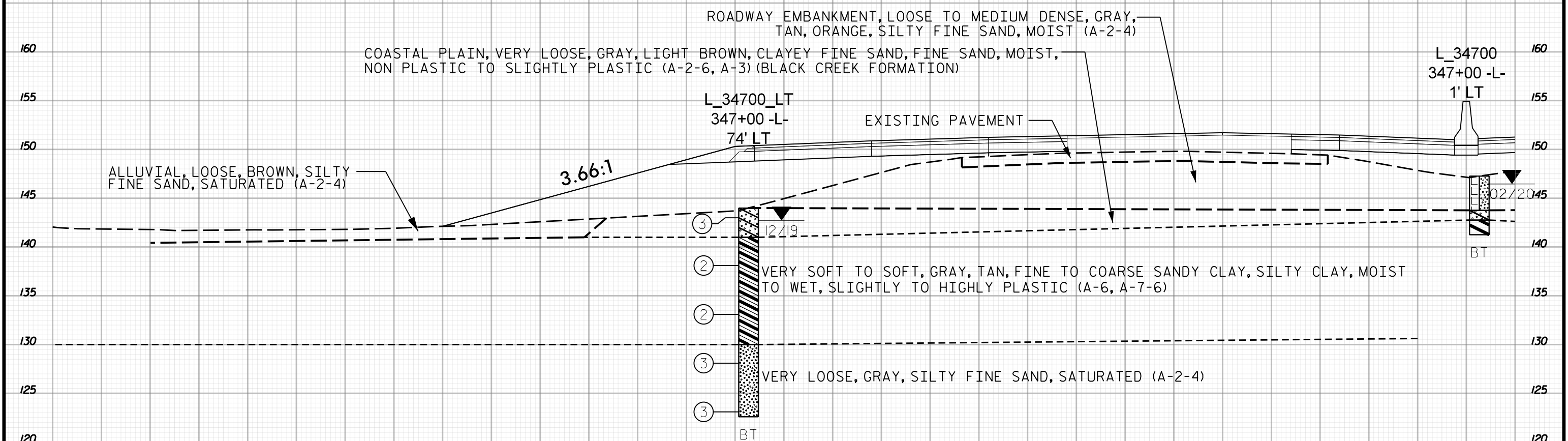

347 + 00

1 OF 2

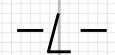

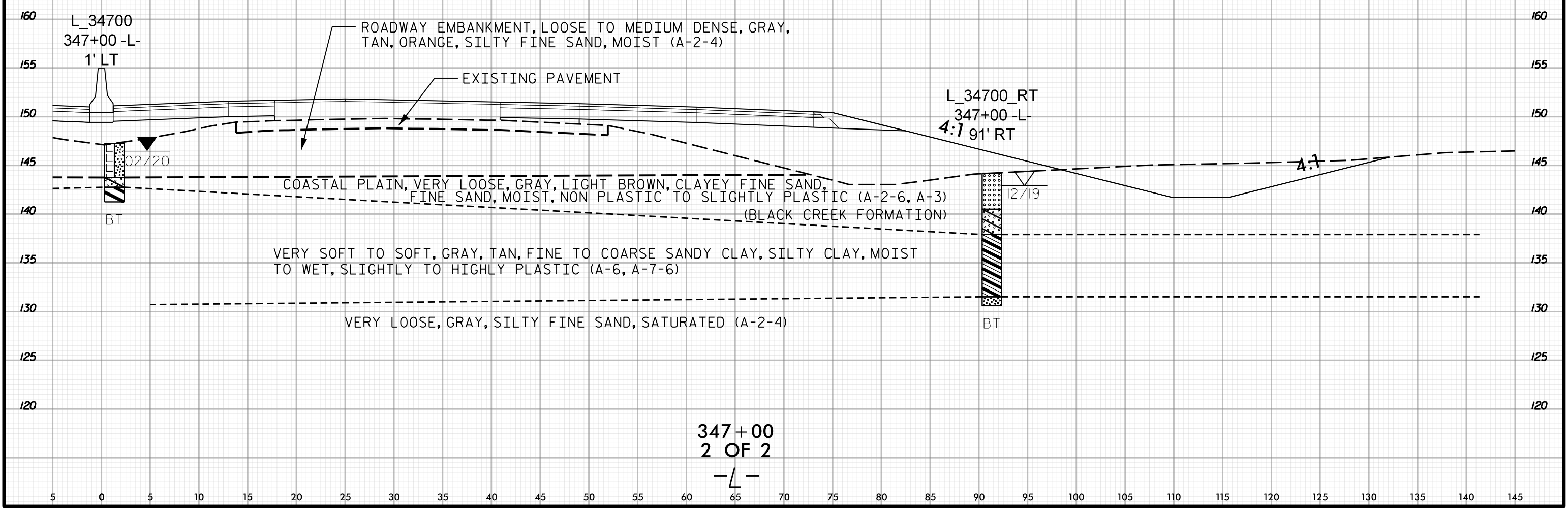
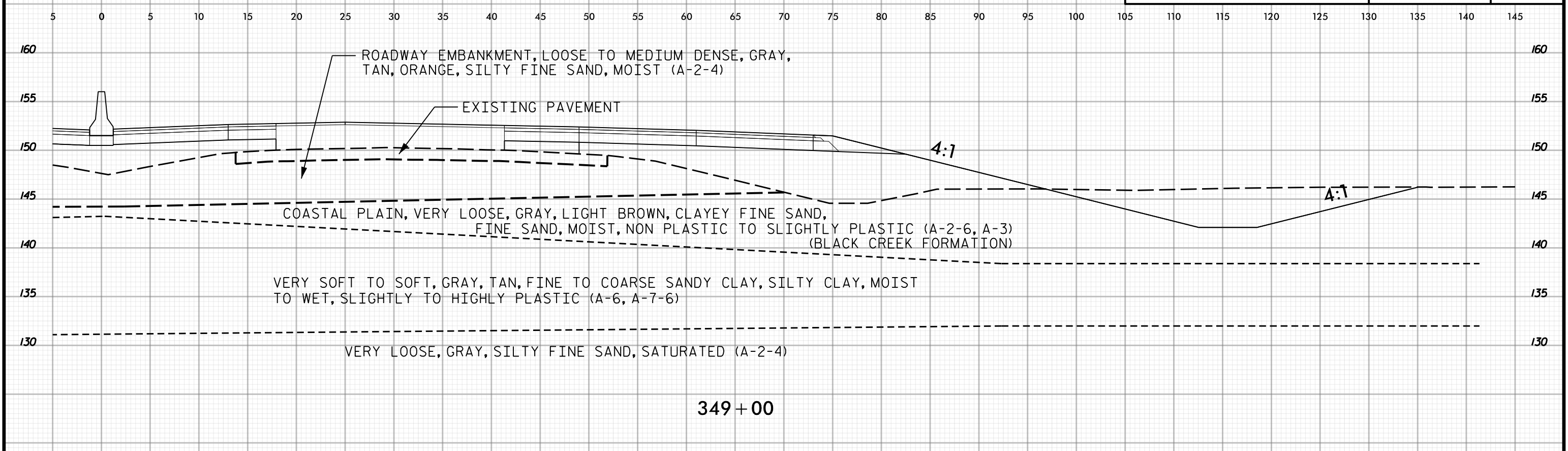
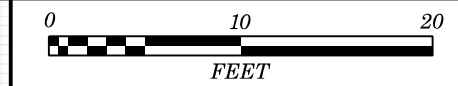



PROJ. REFERENCE NO.	SHEET NO.
I-5987A	594

140 135 130 125 120 115 110 105 100 95 90 85 80 75 70 65 60 55 50 45 40 35 30 25 20 15 10 5 0 5

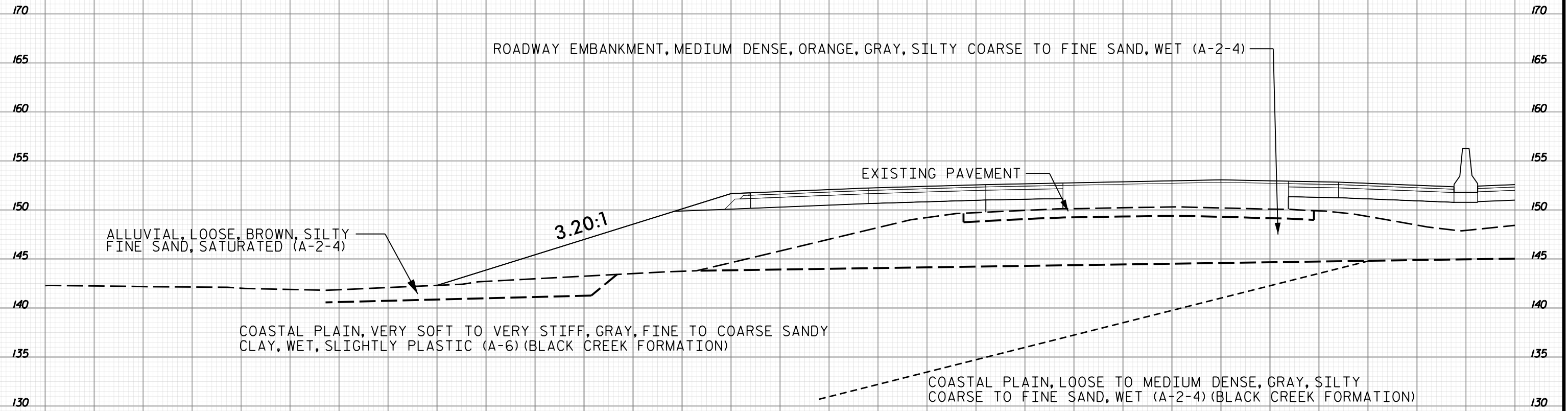

349 + 50
1 OF 2

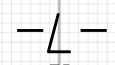

140 135 130 125 120 115 110 105 100 95 90 85 80 75 70 65 60 55 50 45 40 35 30 25 20 15 10 5 0 5



5 0 5 10 15 20 25 30 35 40 45 50 55 60 65 70 75 80 85 90 95 100 105 110 115 120 125 130 135 140 145

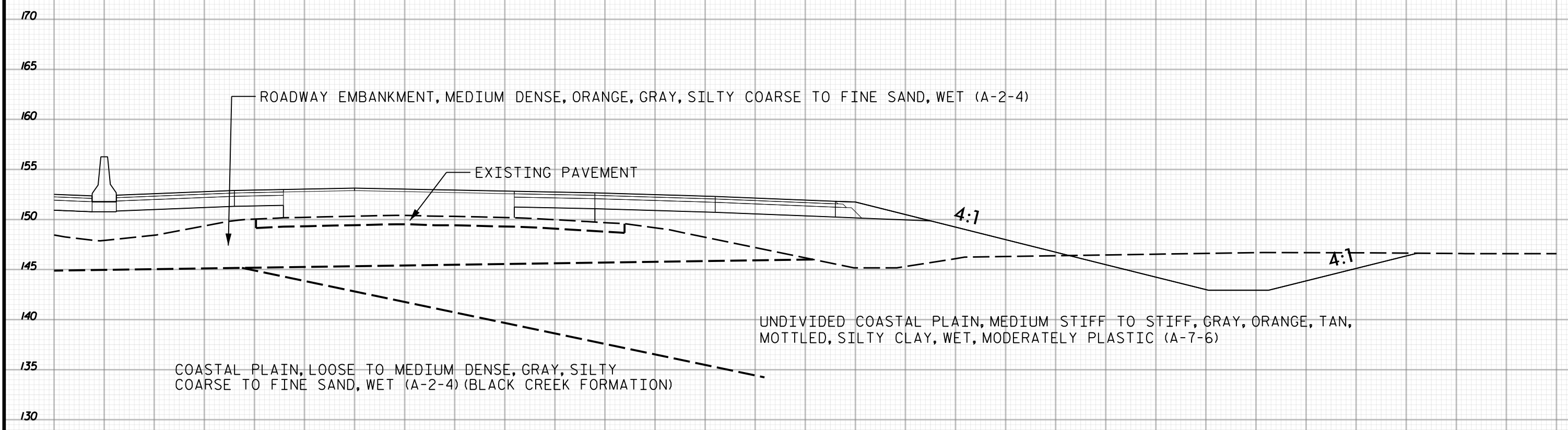

349+50
2 OF 2

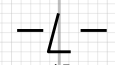

5 0 5 10 15 20 25 30 35 40 45 50 55 60 65 70 75 80 85 90 95 100 105 110 115 120 125 130 135 140 145

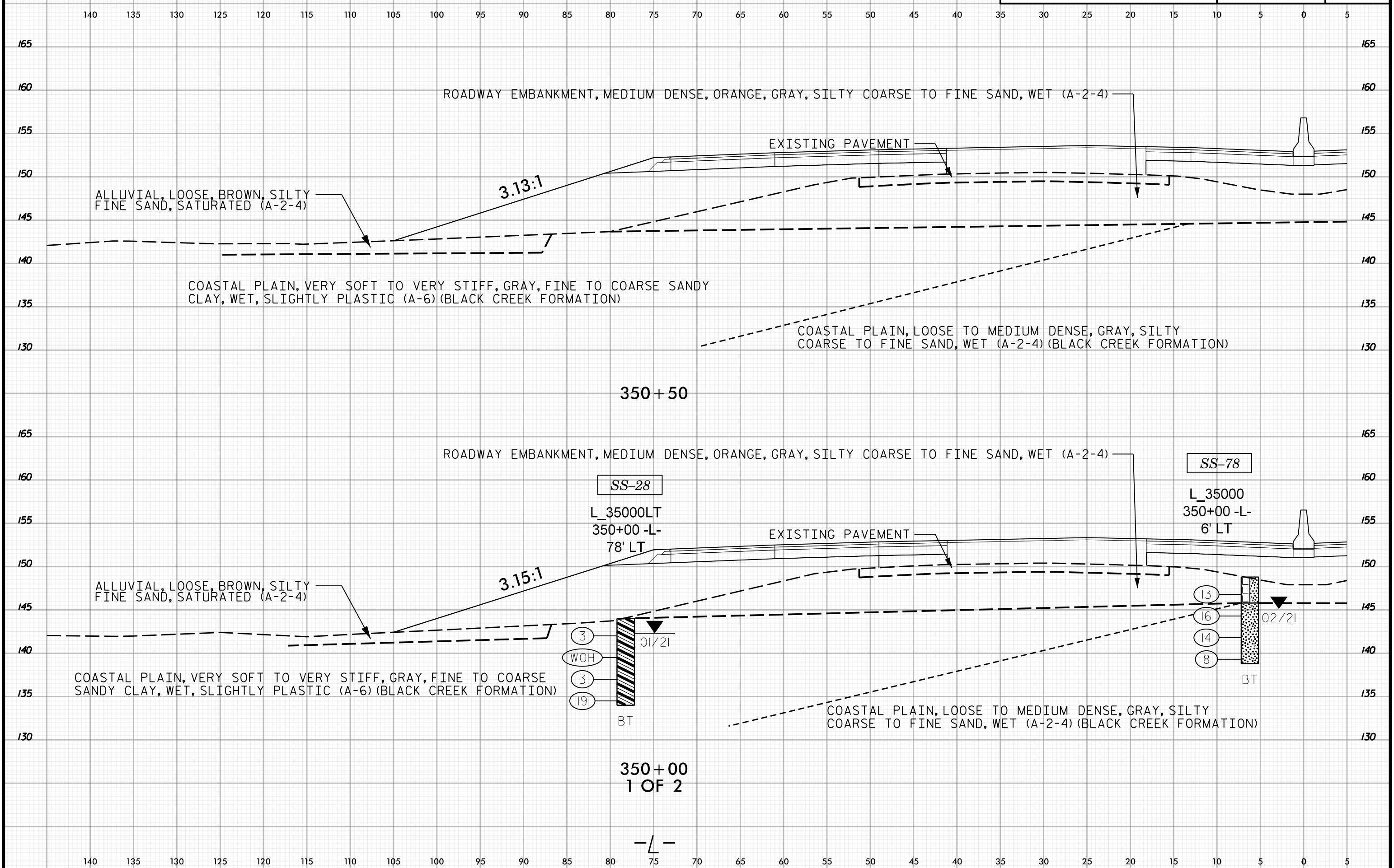

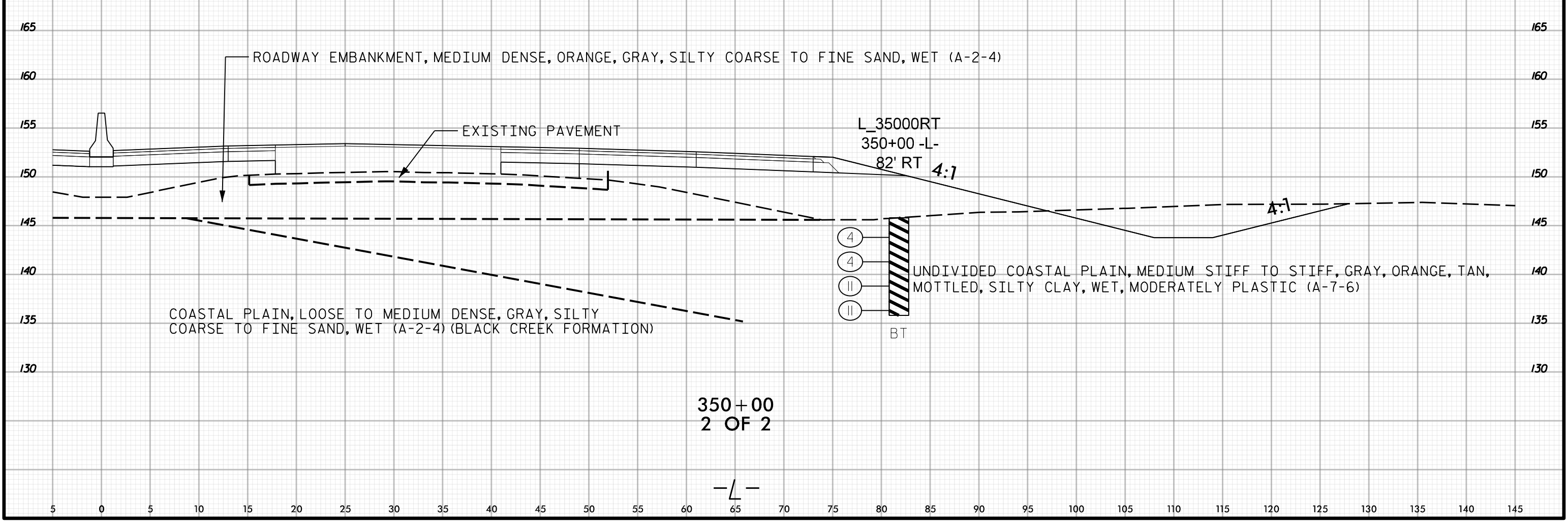
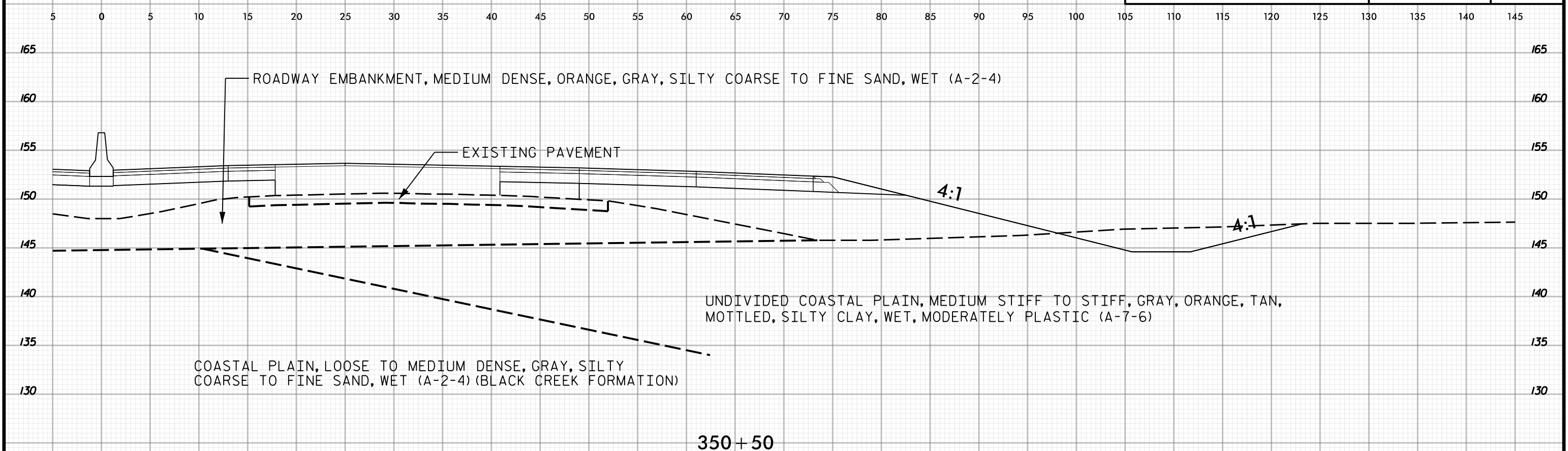
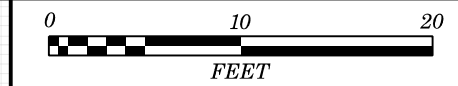



140 135 130 125 120 115 110 105 100 95 90 85 80 75 70 65 60 55 50 45 40 35 30 25 20 15 10 5 0 5

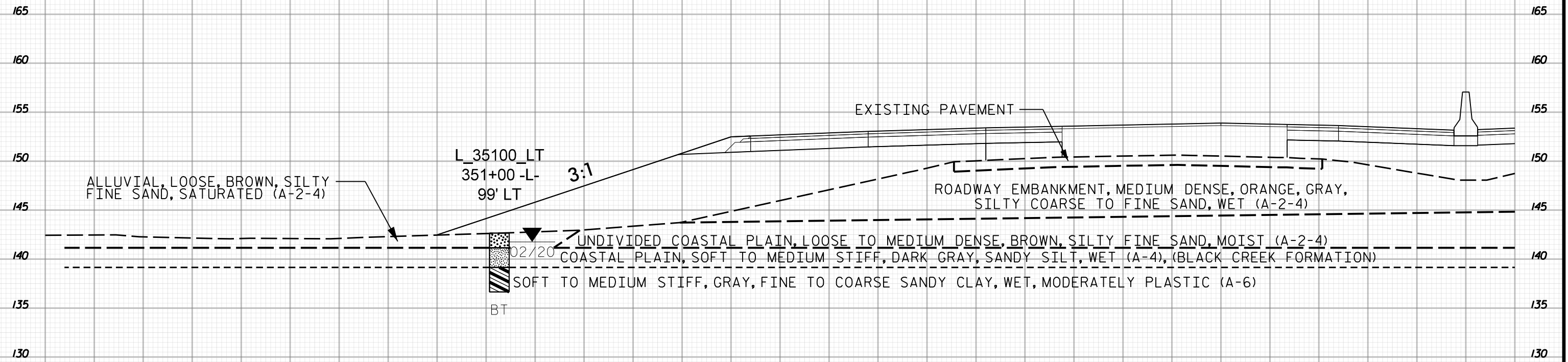

351+00
1 OF 2

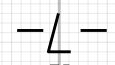

140 135 130 125 120 115 110 105 100 95 90 85 80 75 70 65 60 55 50 45 40 35 30 25 20 15 10 5 0 5

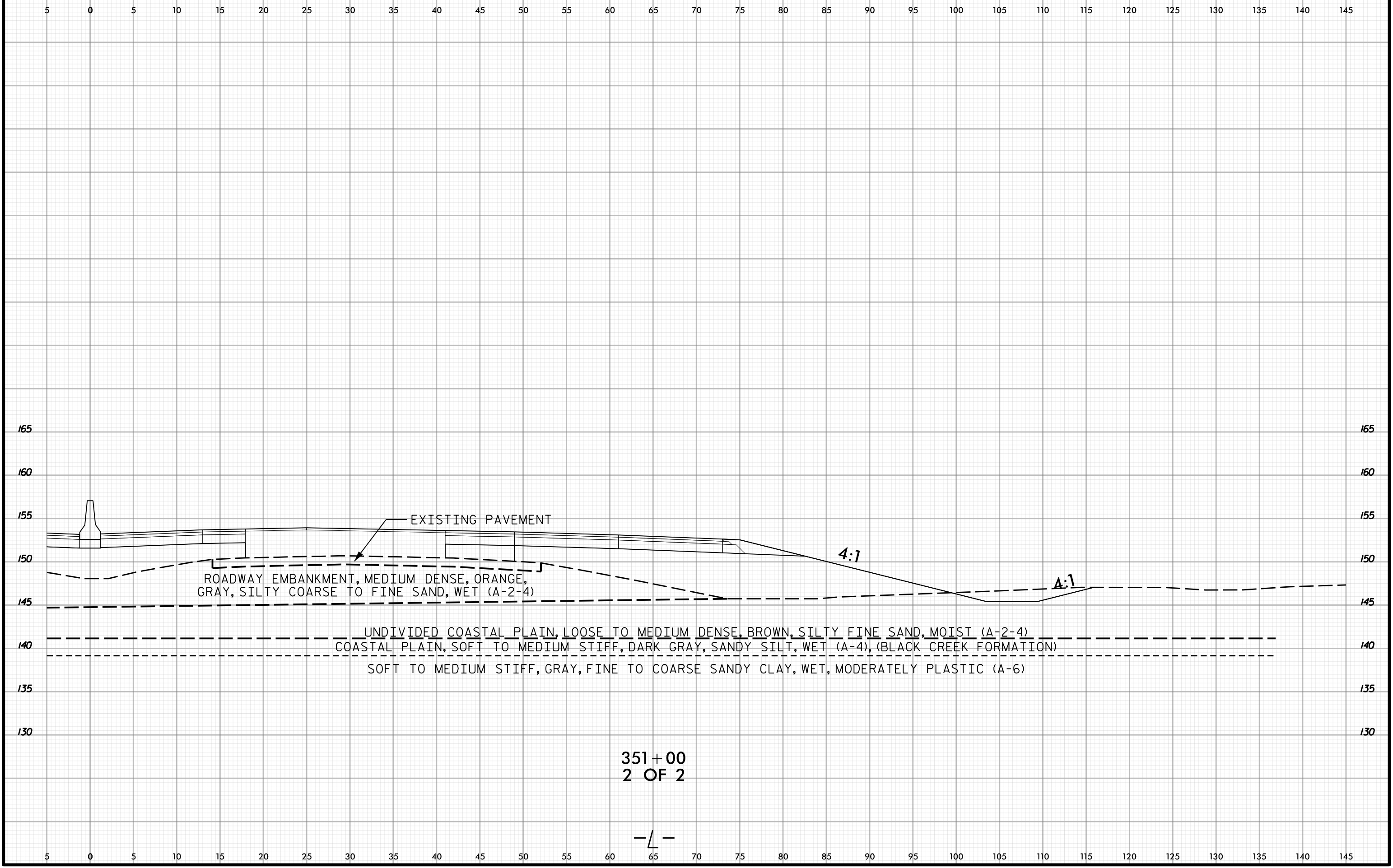

351+00
2 OF 2

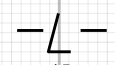



PROJ. REFERENCE NO.	SHEET NO.
I-5987A	600

140 135 130 125 120 115 110 105 100 95 90 85 80 75 70 65 60 55 50 45 40 35 30 25 20 15 10 5 0 5

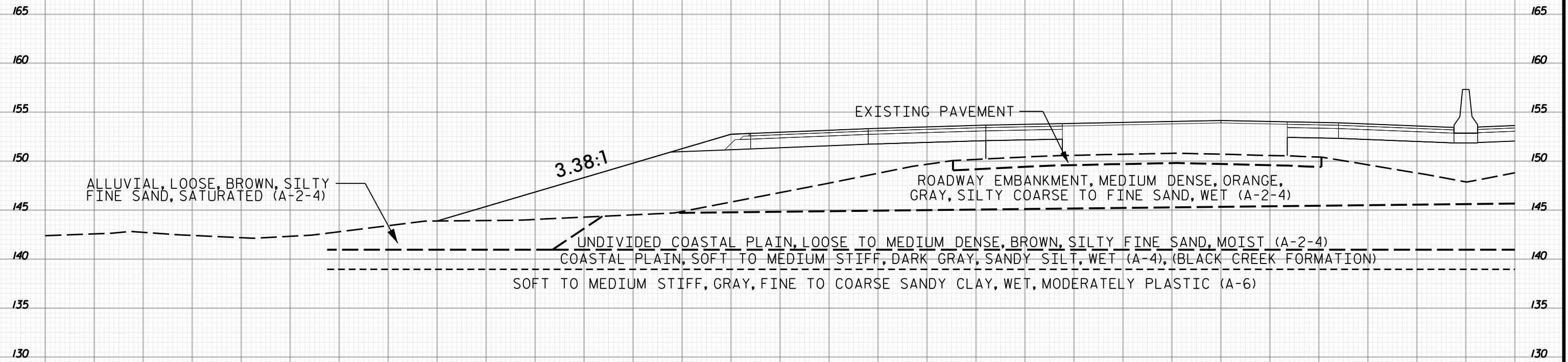

351+50
1 OF 2

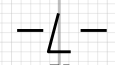

140 135 130 125 120 115 110 105 100 95 90 85 80 75 70 65 60 55 50 45 40 35 30 25 20 15 10 5 0 5



PROJ. REFERENCE NO.	SHEET NO.
I-5987A	601

5 0 5 10 15 20 25 30 35 40 45 50 55 60 65 70 75 80 85 90 95 100 105 110 115 120 125 130 135 140 145

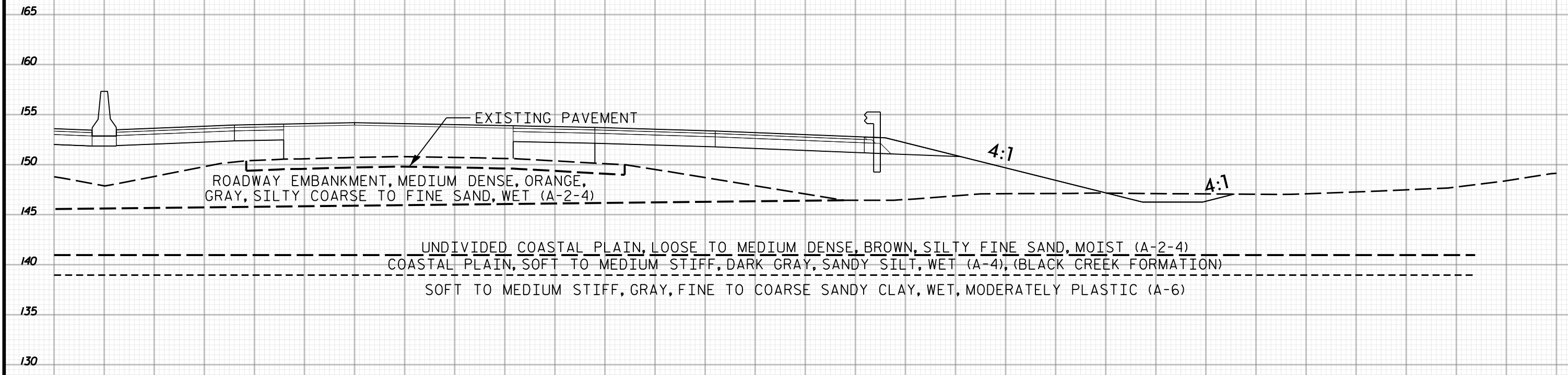

351+50
2 OF 2

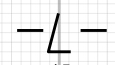

5 0 5 10 15 20 25 30 35 40 45 50 55 60 65 70 75 80 85 90 95 100 105 110 115 120 125 130 135 140 145

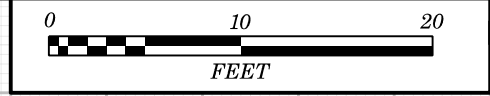

140 135 130 125 120 115 110 105 100 95 90 85 80 75 70 65 60 55 50 45 40 35 30 25 20 15 10 5 0 5

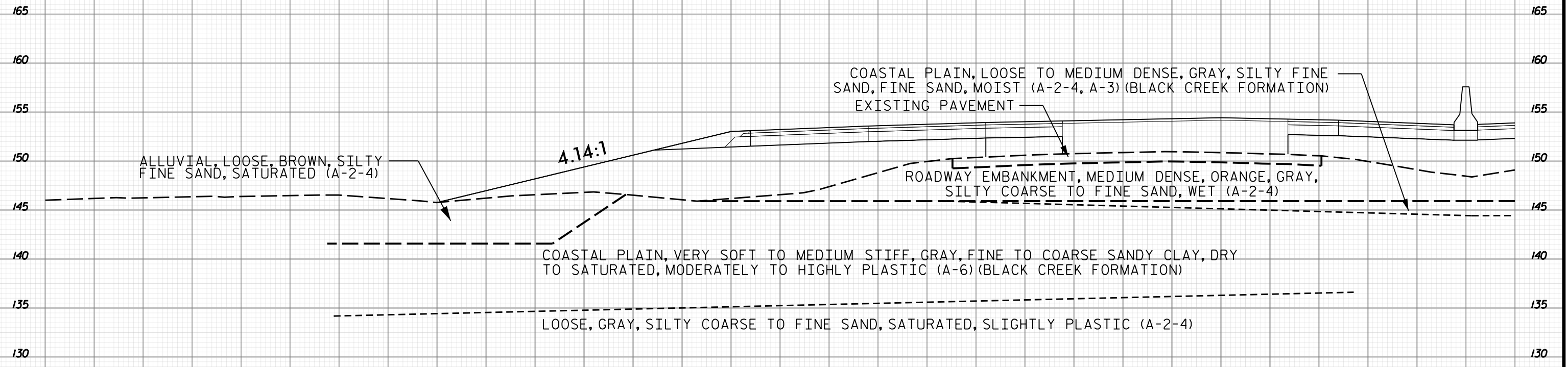

352+00
1 OF 2

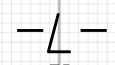

140 135 130 125 120 115 110 105 100 95 90 85 80 75 70 65 60 55 50 45 40 35 30 25 20 15 10 5 0 5



5 0 5 10 15 20 25 30 35 40 45 50 55 60 65 70 75 80 85 90 95 100 105 110 115 120 125 130 135 140 145

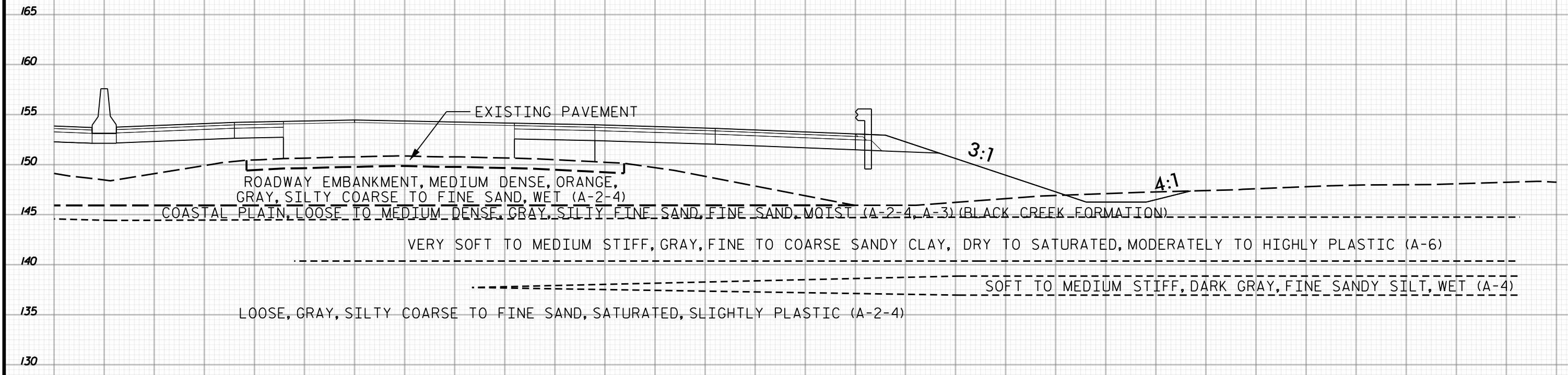

352+00
2 OF 2

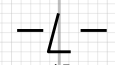

5 0 5 10 15 20 25 30 35 40 45 50 55 60 65 70 75 80 85 90 95 100 105 110 115 120 125 130 135 140 145

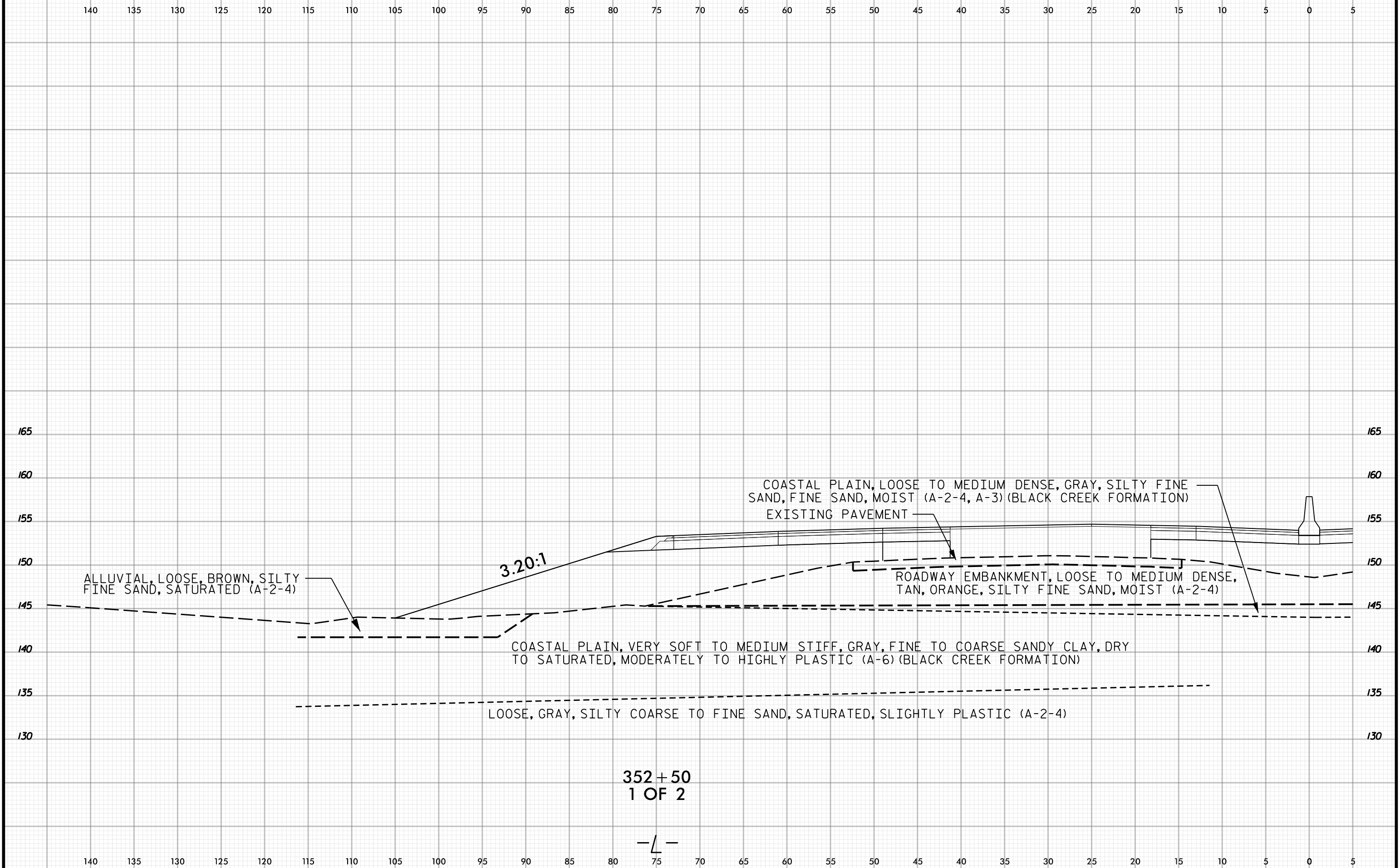
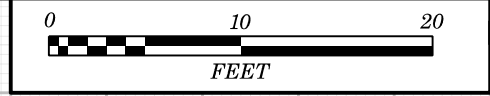



5 0 5 10 15 20 25 30 35 40 45 50 55 60 65 70 75 80 85 90 95 100 105 110 115 120 125 130 135 140 145

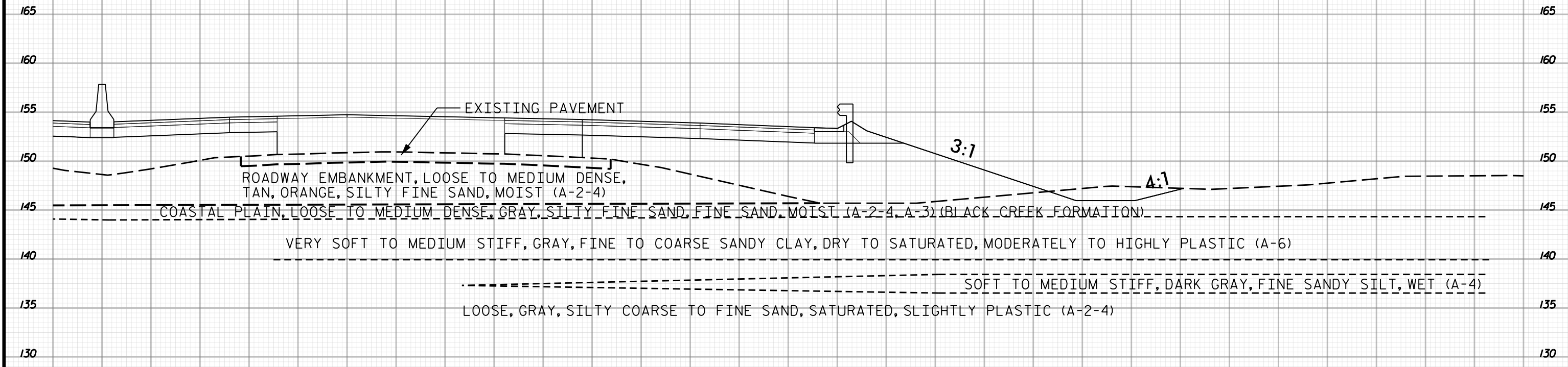

352+50
2 OF 2

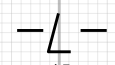

5 0 5 10 15 20 25 30 35 40 45 50 55 60 65 70 75 80 85 90 95 100 105 110 115 120 125 130 135 140 145

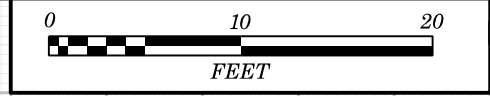

140 135 130 125 120 115 110 105 100 95 90 85 80 75 70 65 60 55 50 45 40 35 30 25 20 15 10 5 0 5

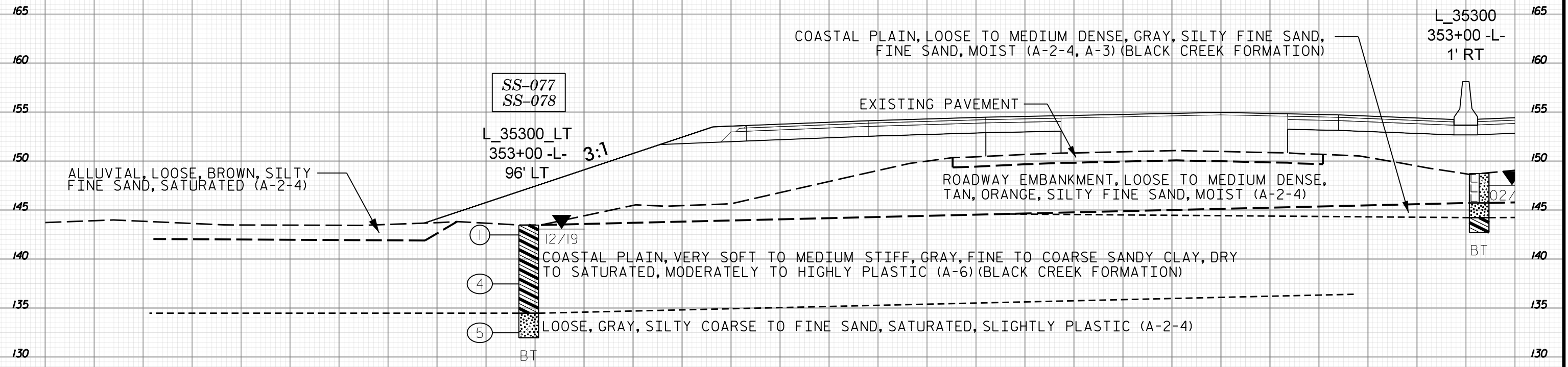

353 + 00
1 OF 2

140 135 130 125 120 115 110 105 100 95 90 85 80 75 70 65 60 55 50 45 40 35 30 25 20 15 10 5 0 5



5 0 5 10 15 20 25 30 35 40 45 50 55 60 65 70 75 80 85 90 95 100 105 110 115 120 125 130 135 140 145

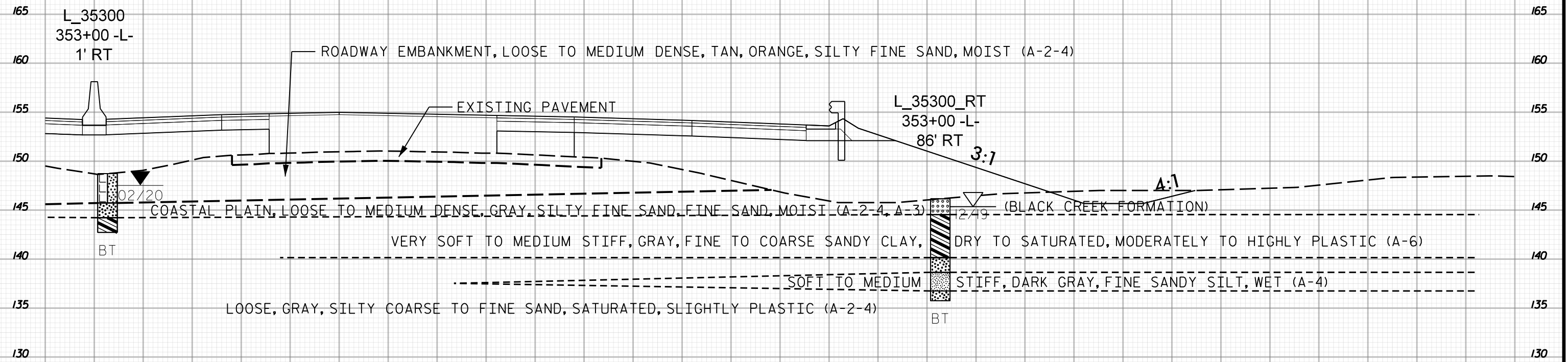

165 160 155 150 145 140 135 130

353+00
 2 OF 2

-L-

5 0 5 10 15 20 25 30 35 40 45 50 55 60 65 70 75 80 85 90 95 100 105 110 115 120 125 130 135 140 145

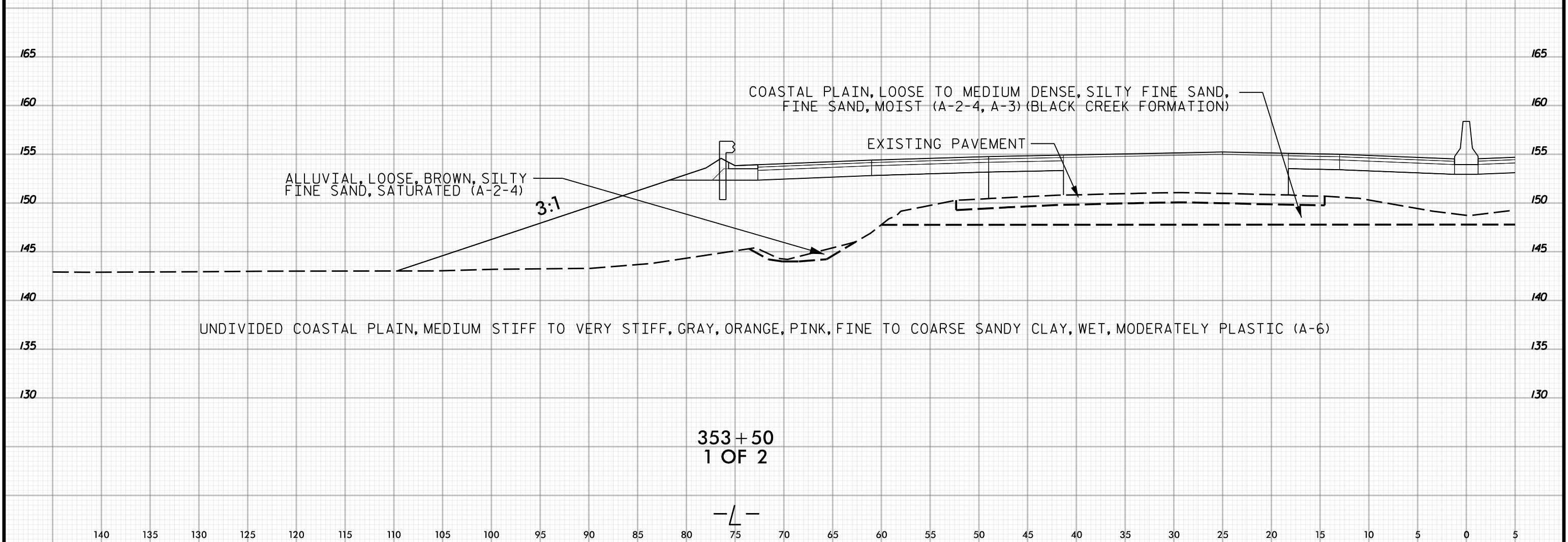
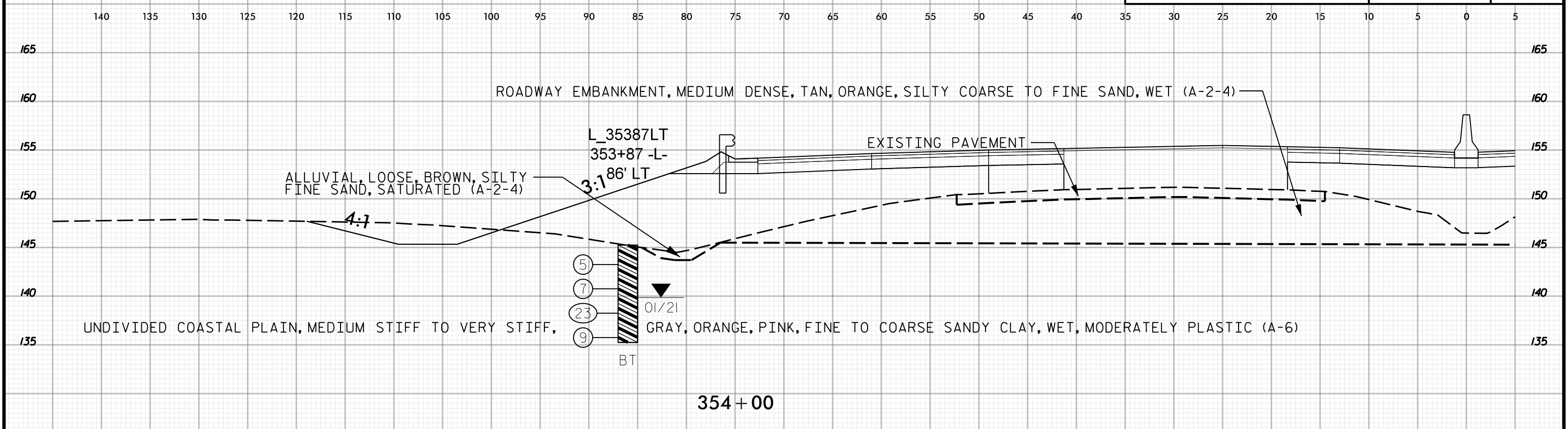

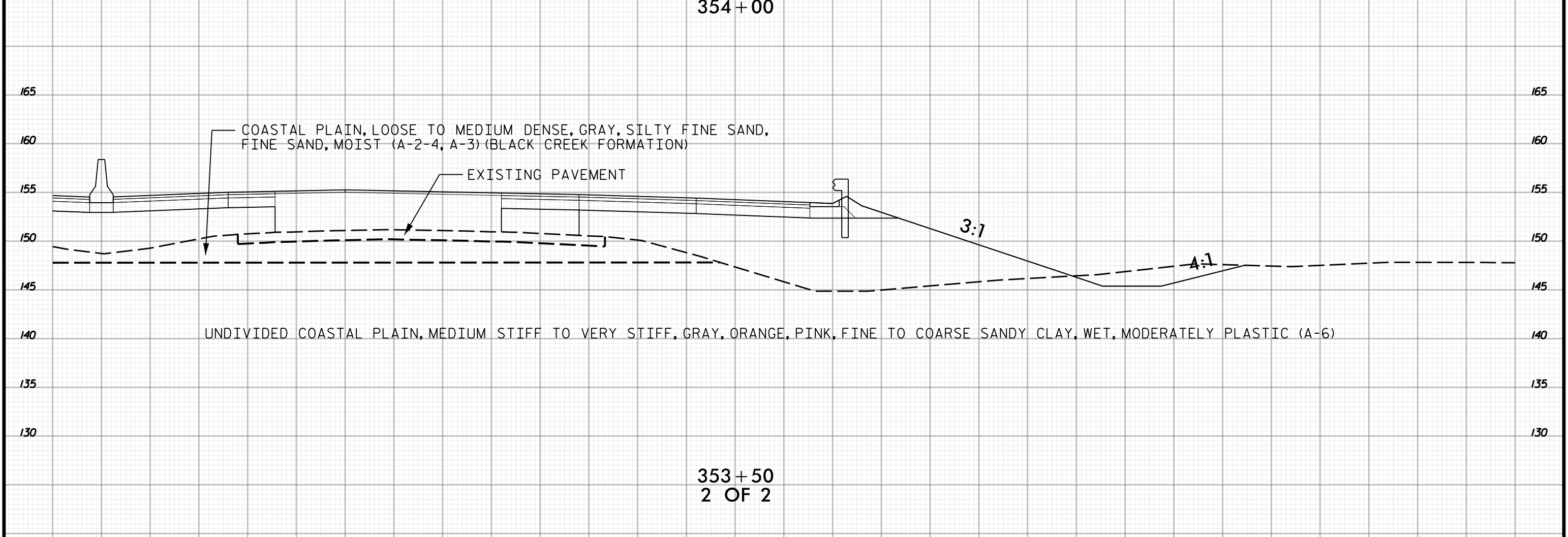
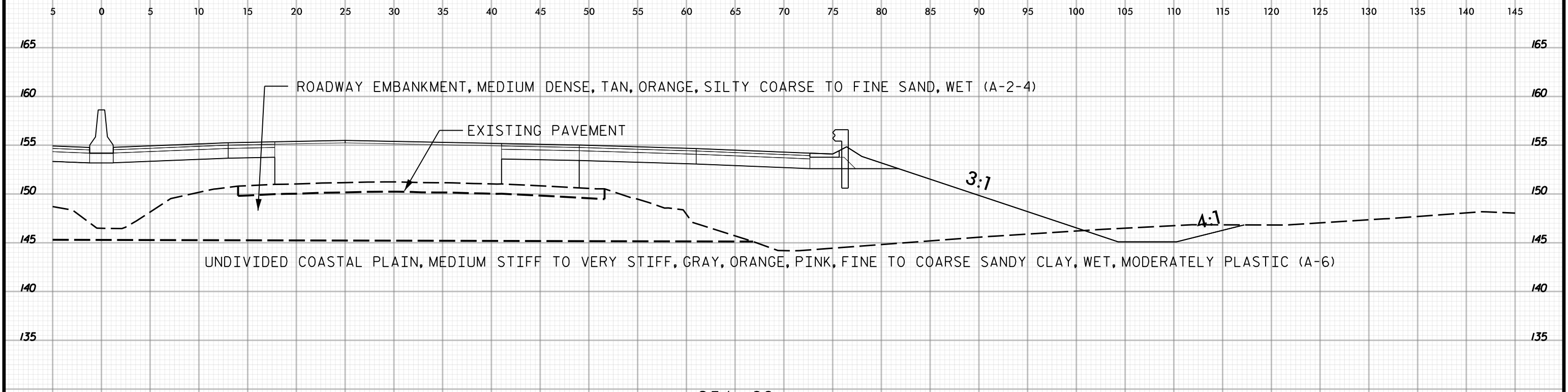
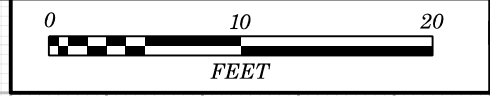

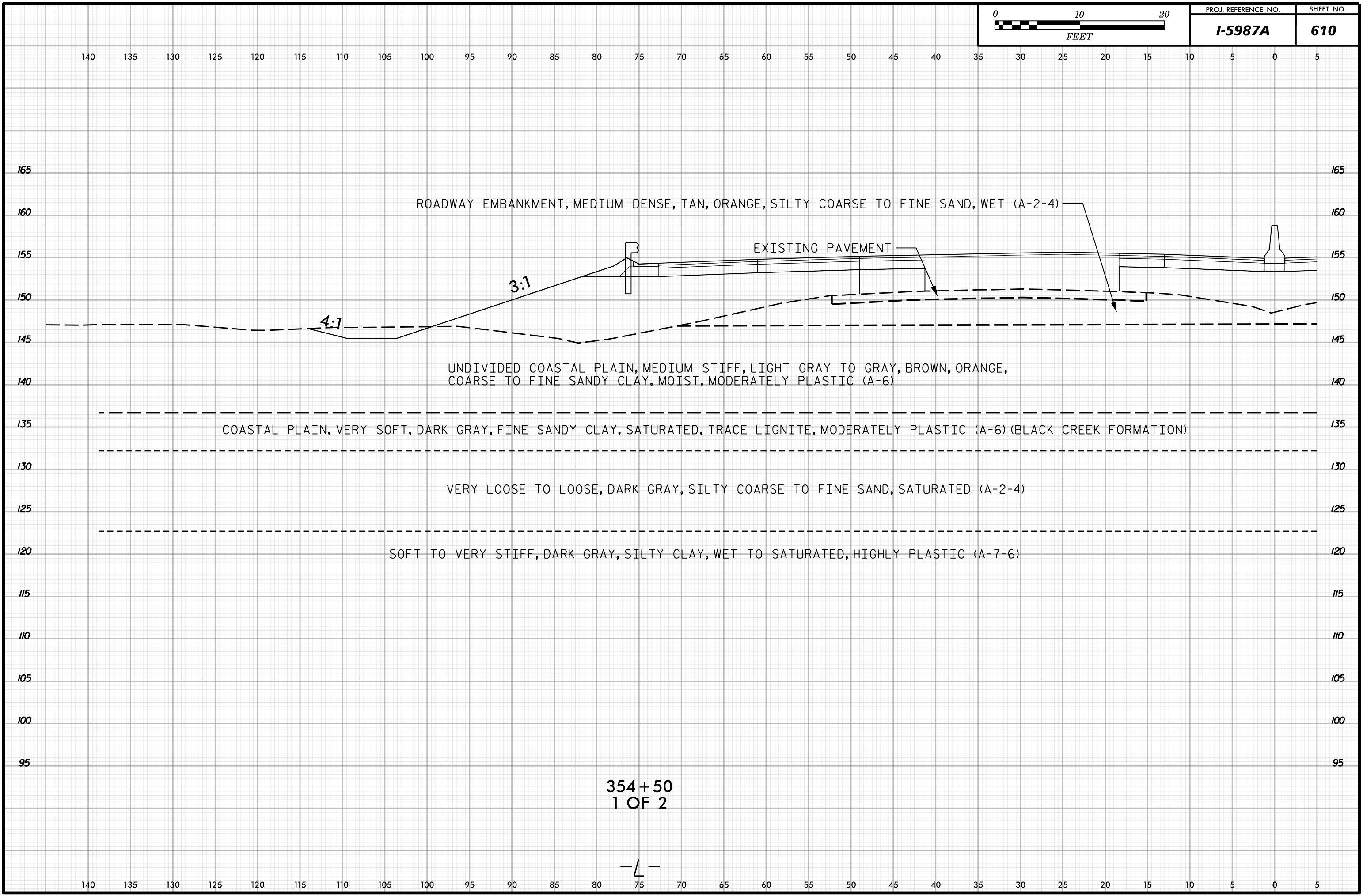

ROADWAY EMBANKMENT, MEDIUM DENSE, TAN, ORANGE, SILTY COARSE TO FINE SAND, WET (A-2-4)

EXISTING PAVEMENT

3:1

4:1

UNDIVIDED COASTAL PLAIN, MEDIUM STIFF, LIGHT GRAY TO GRAY, BROWN, ORANGE, COARSE TO FINE SANDY CLAY, MOIST, MODERATELY PLASTIC (A-6)

COASTAL PLAIN, VERY SOFT, DARK GRAY, FINE SANDY CLAY, SATURATED, TRACE LIGNITE, MODERATELY PLASTIC (A-6) (BLACK CREEK FORMATION)

VERY LOOSE TO LOOSE, DARK GRAY, SILTY COARSE TO FINE SAND, SATURATED (A-2-4)

SOFT TO VERY STIFF, DARK GRAY, SILTY CLAY, WET TO SATURATED, HIGHLY PLASTIC (A-7-6)

354 + 50
1 OF 2

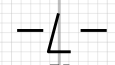

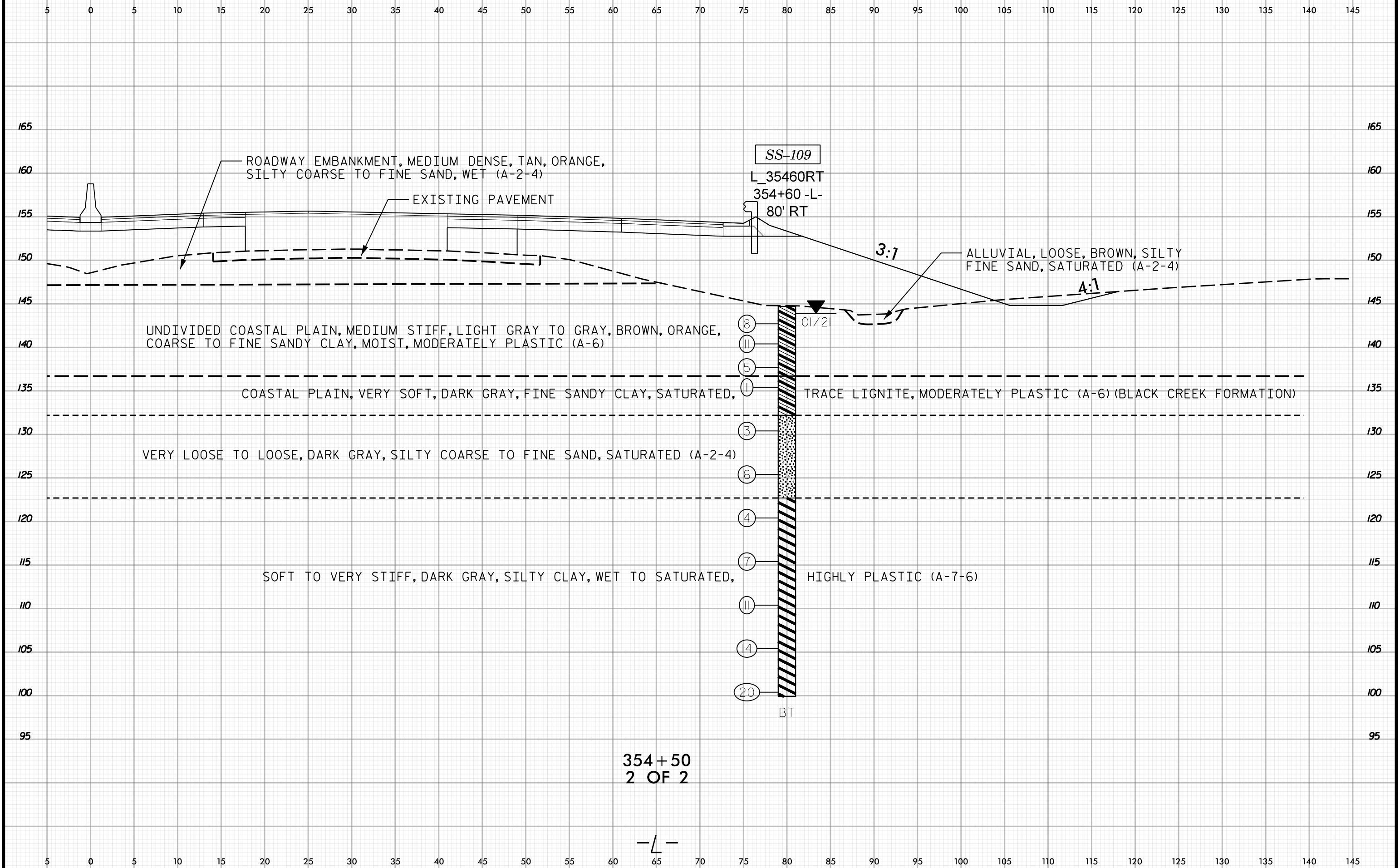

354+50
2 OF 2

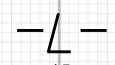

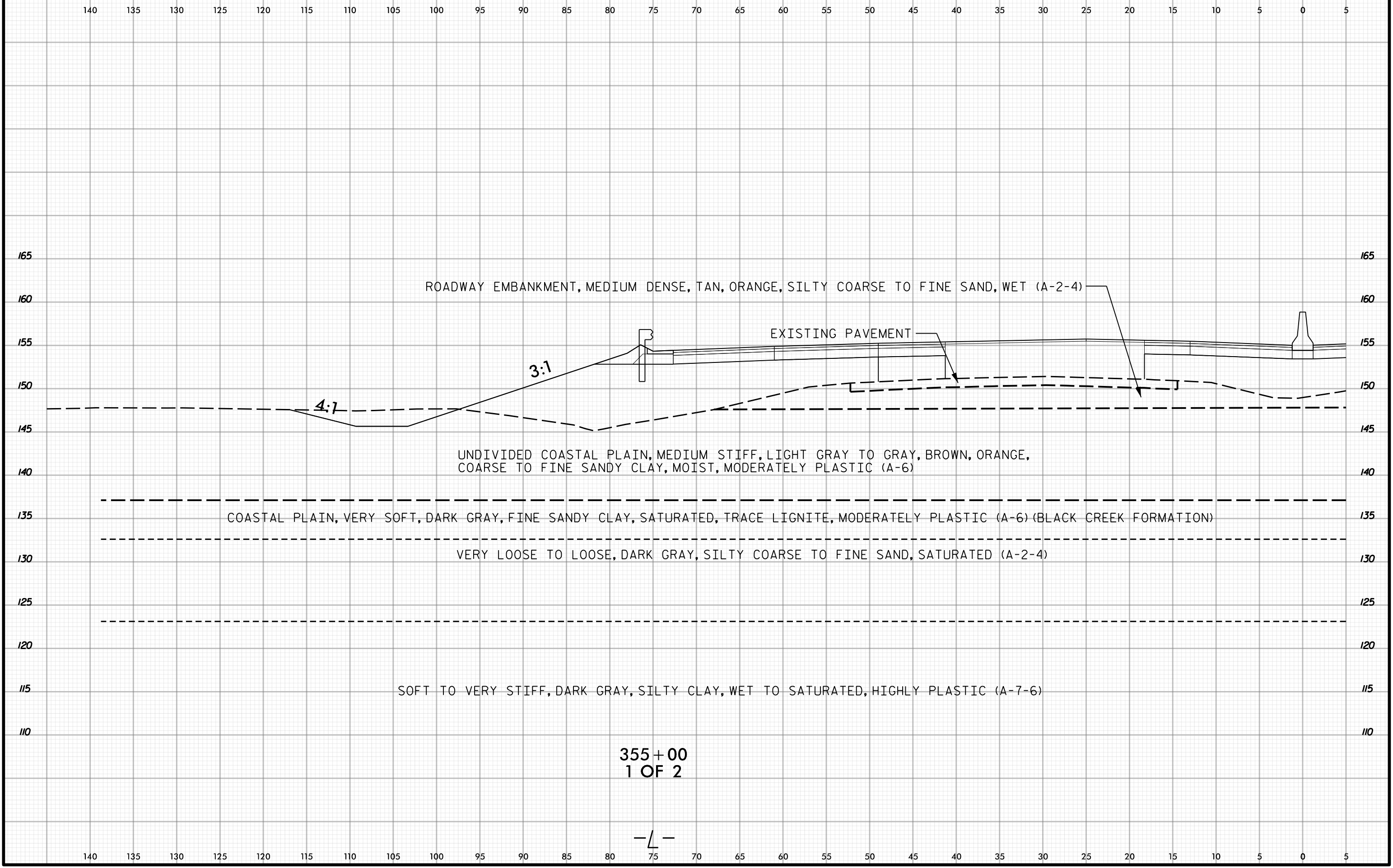

355+00
1 OF 2

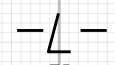

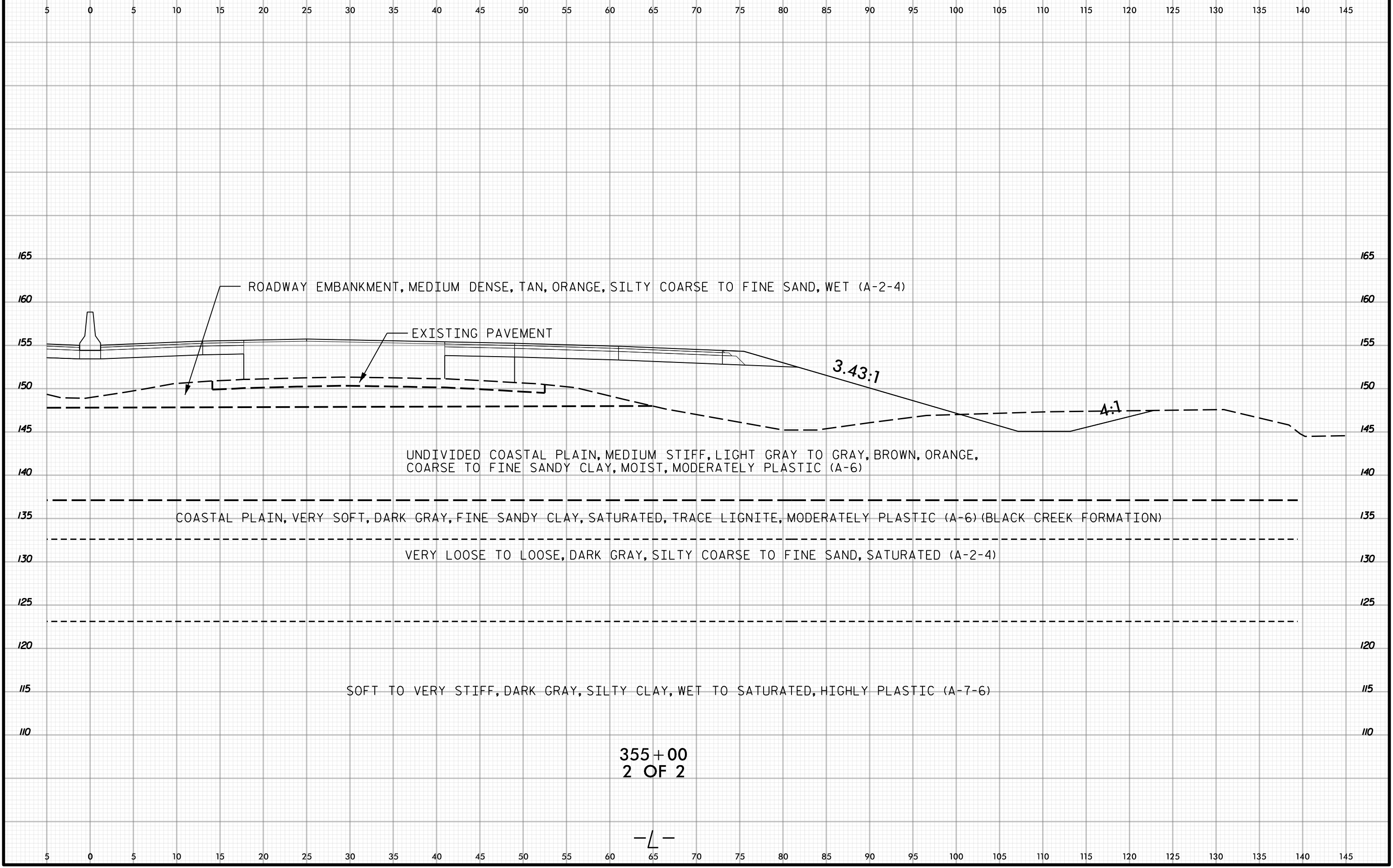
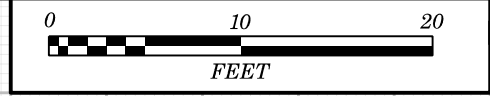

355+00
2 OF 2

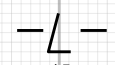



140 135 130 125 120 115 110 105 100 95 90 85 80 75 70 65 60 55 50 45 40 35 30 25 20 15 10 5 0 5

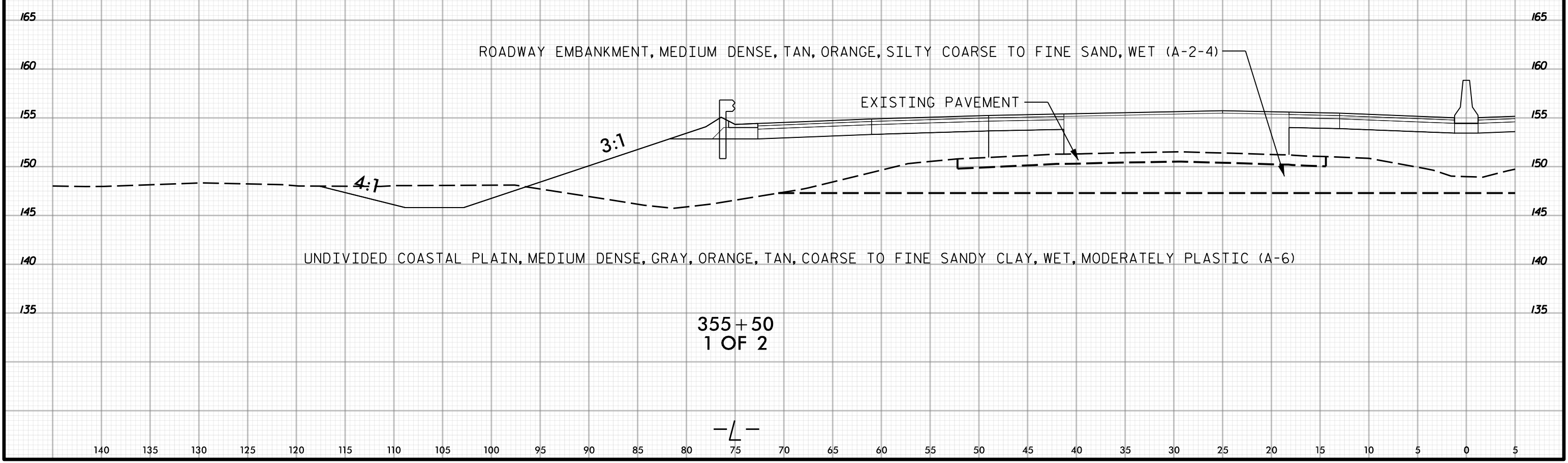
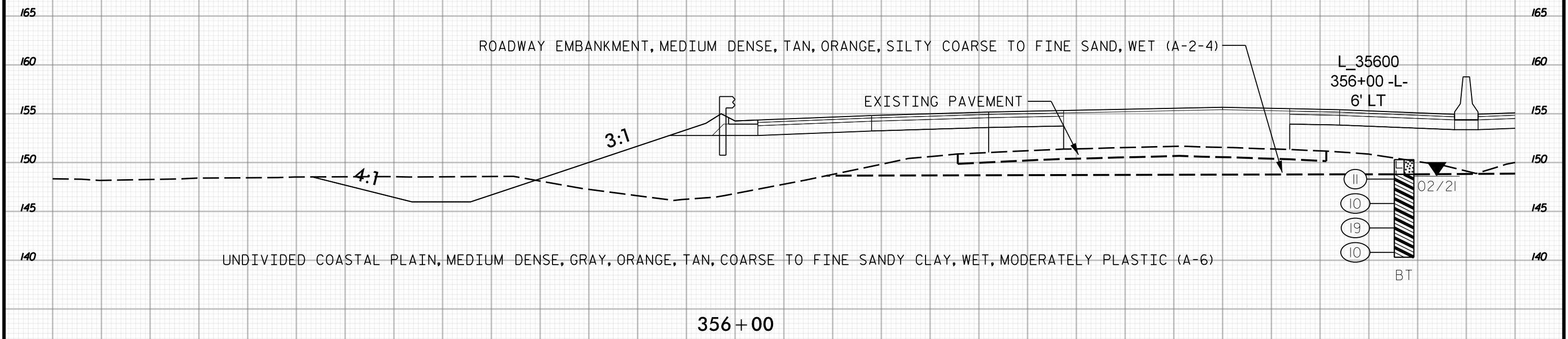

140 135 130 125 120 115 110 105 100 95 90 85 80 75 70 65 60 55 50 45 40 35 30 25 20 15 10 5 0 5

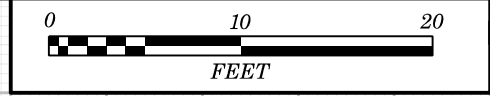

PROJ. REFERENCE NO.	SHEET NO.
I-5987A	615

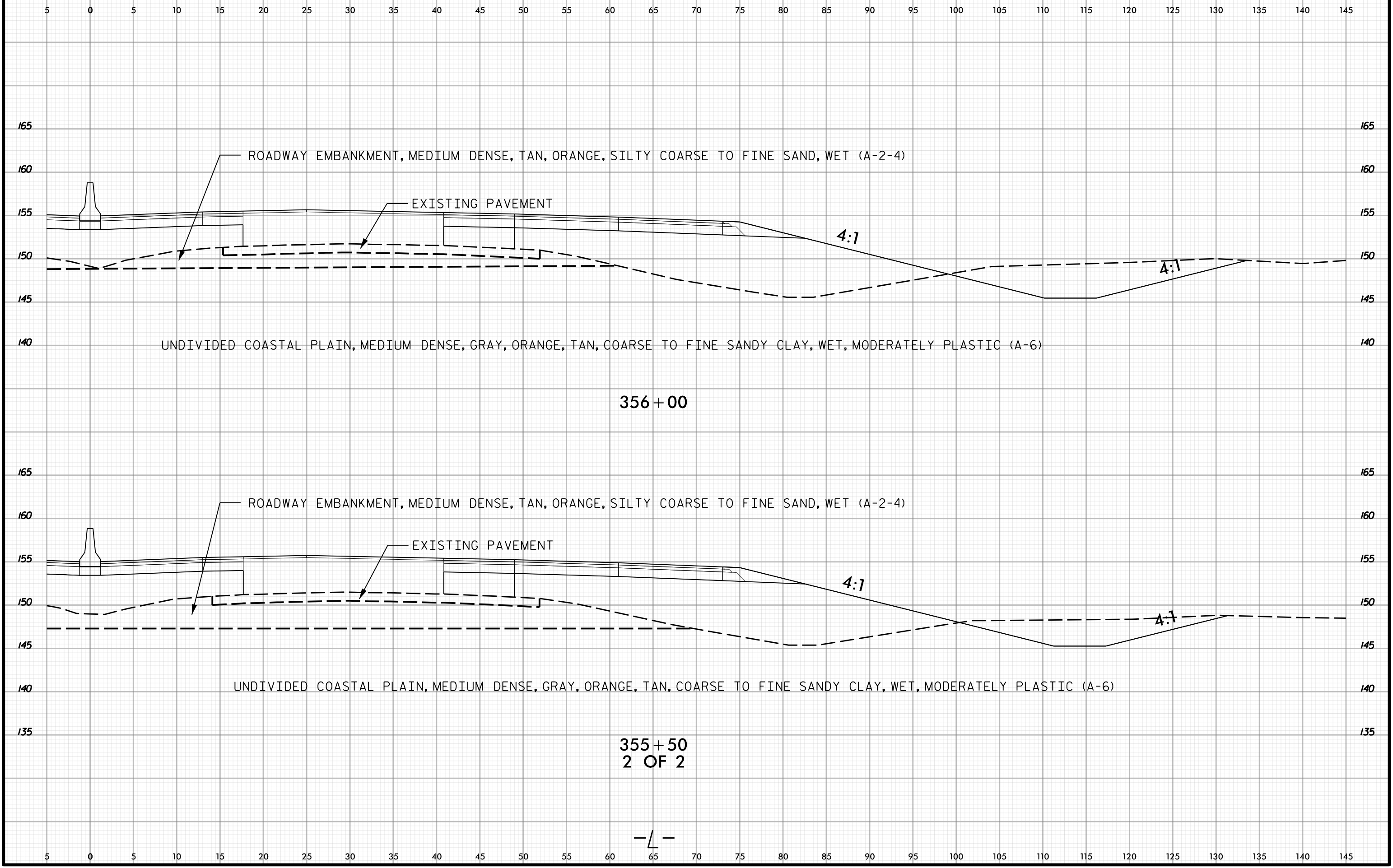

356+00

355+50
2 OF 2

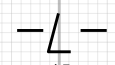

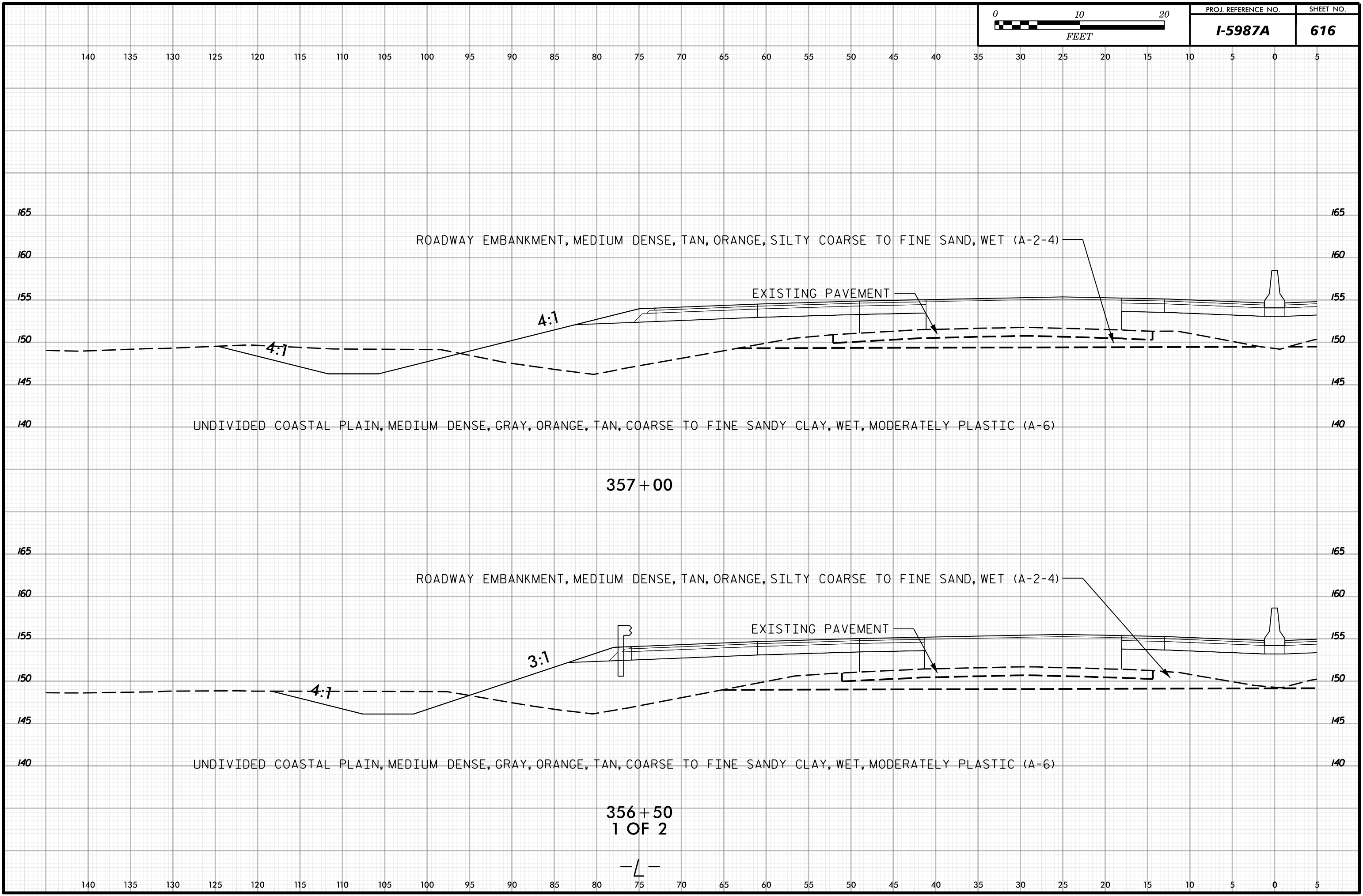

357+00

356+50
1 OF 2

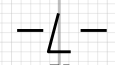

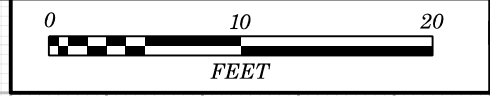

5 0 5 10 15 20 25 30 35 40 45 50 55 60 65 70 75 80 85 90 95 100 105 110 115 120 125 130 135 140 145

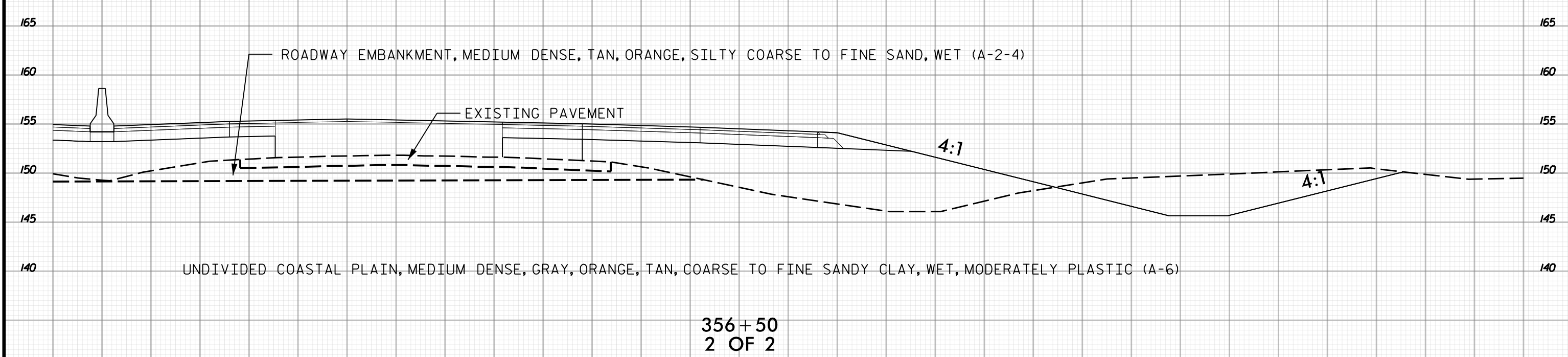
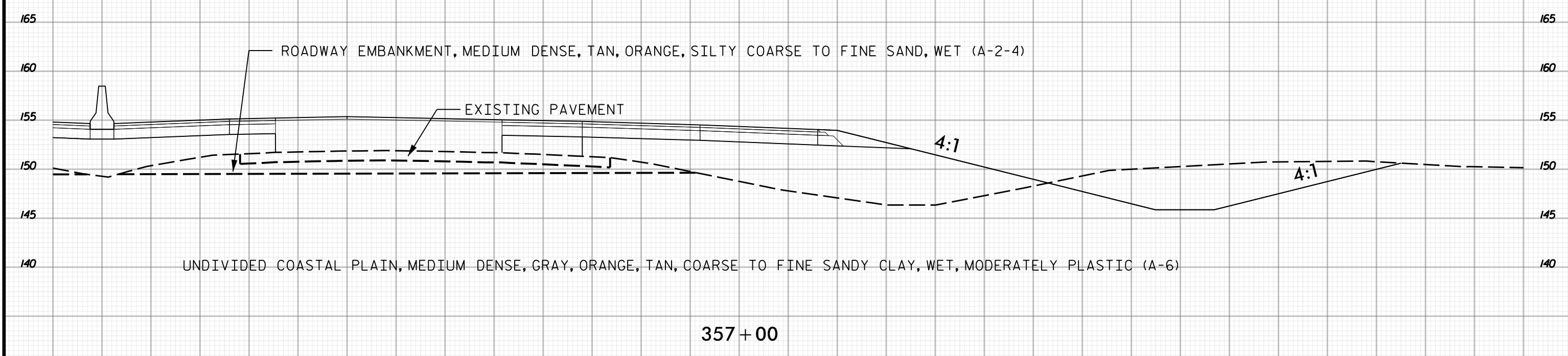

356+50
2 OF 2

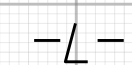

5 0 5 10 15 20 25 30 35 40 45 50 55 60 65 70 75 80 85 90 95 100 105 110 115 120 125 130 135 140 145

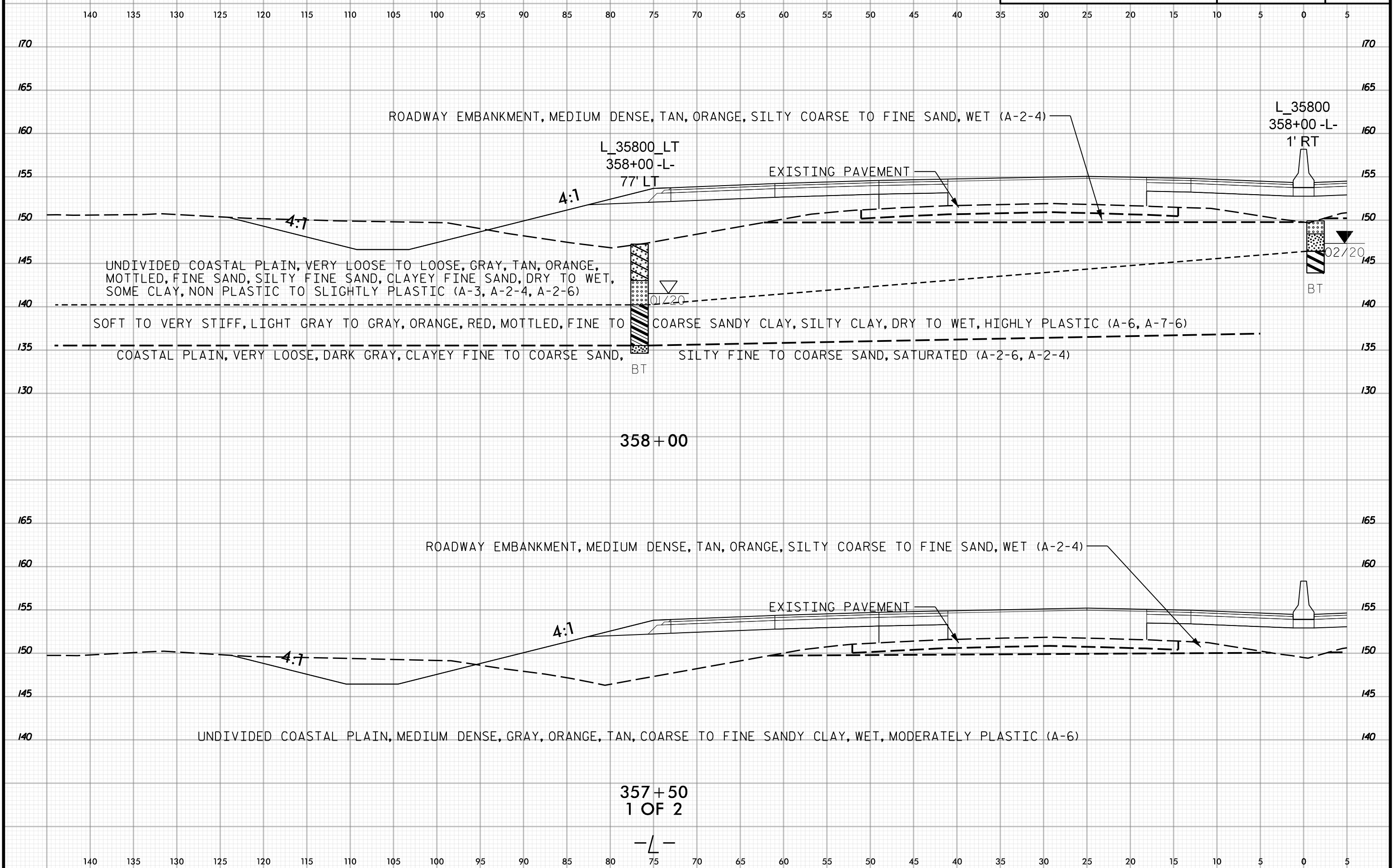

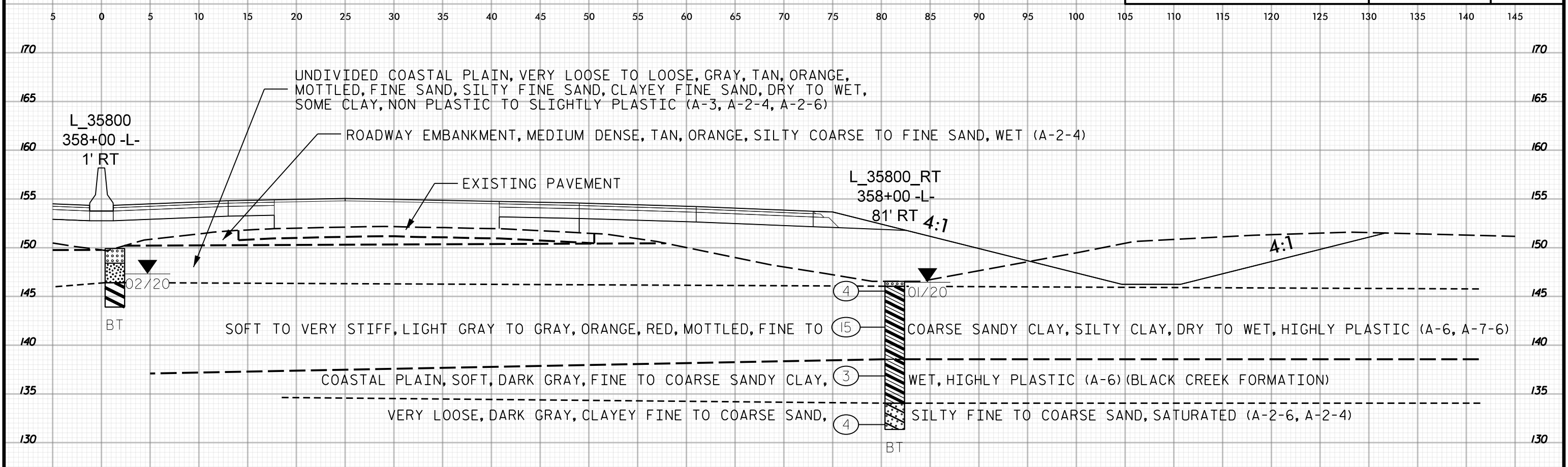

358+00

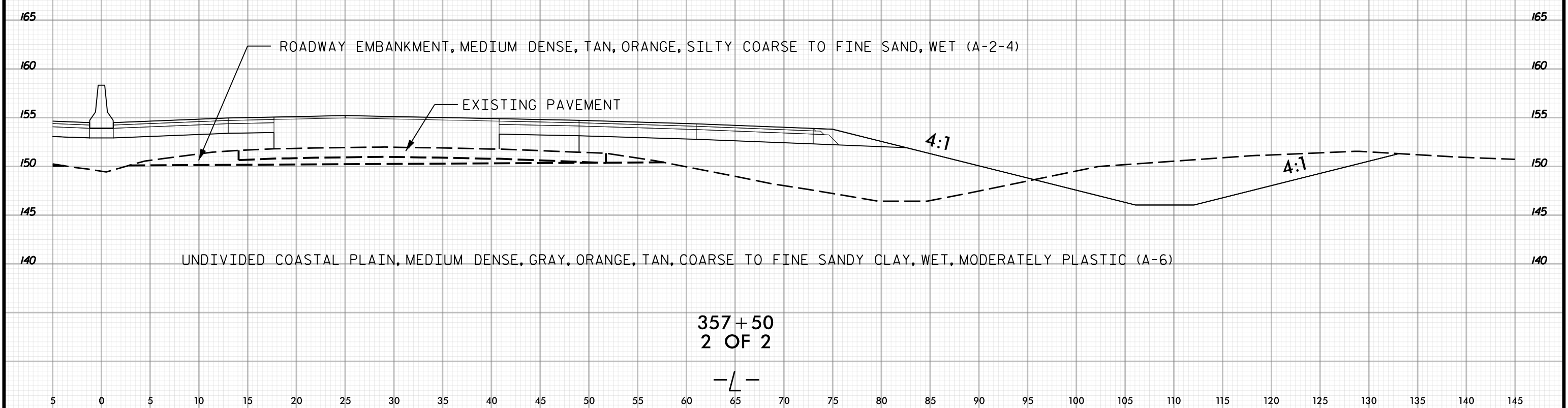

357+50
2 OF 2

-L-

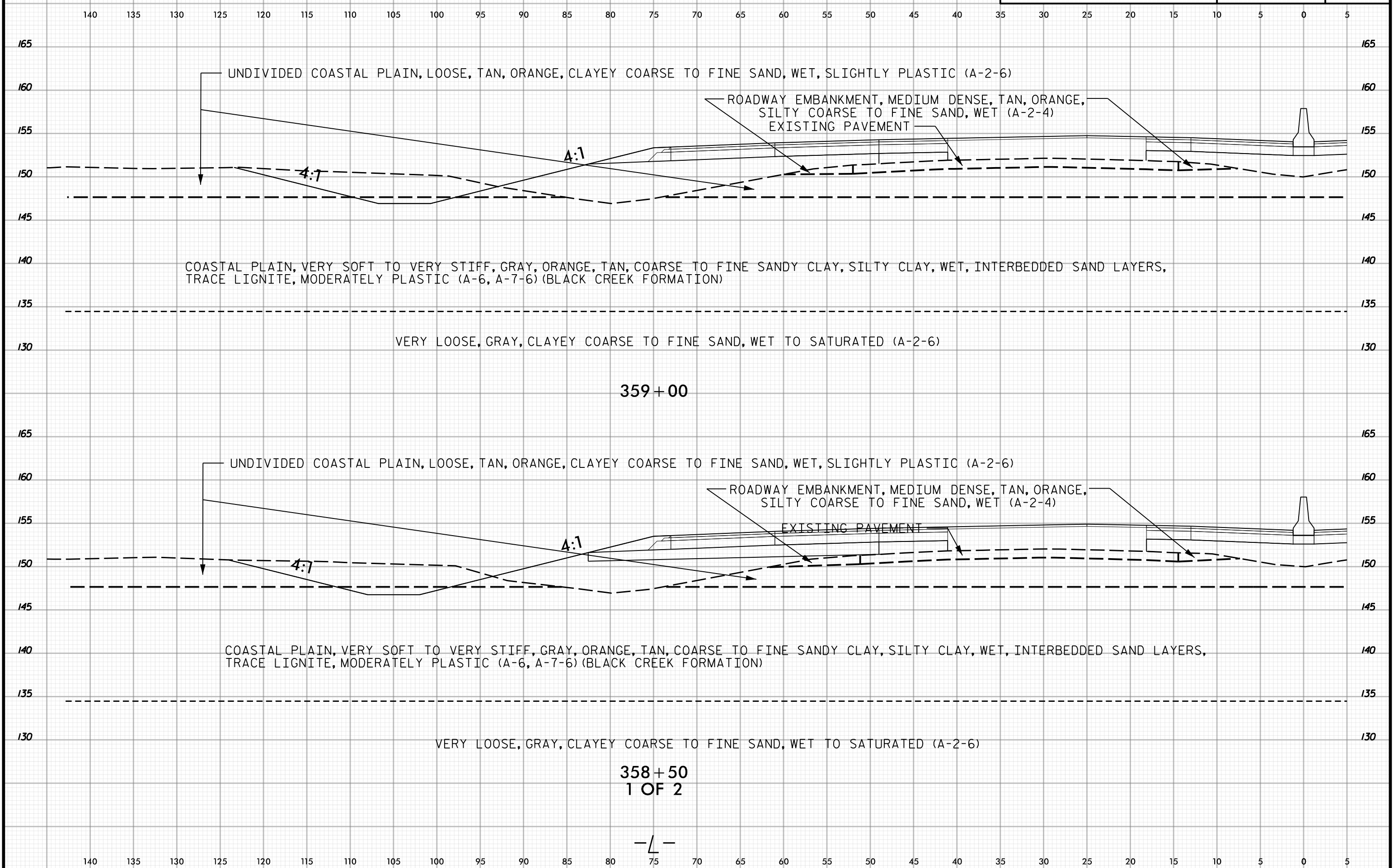

359+00

358+50
1 OF 2

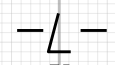

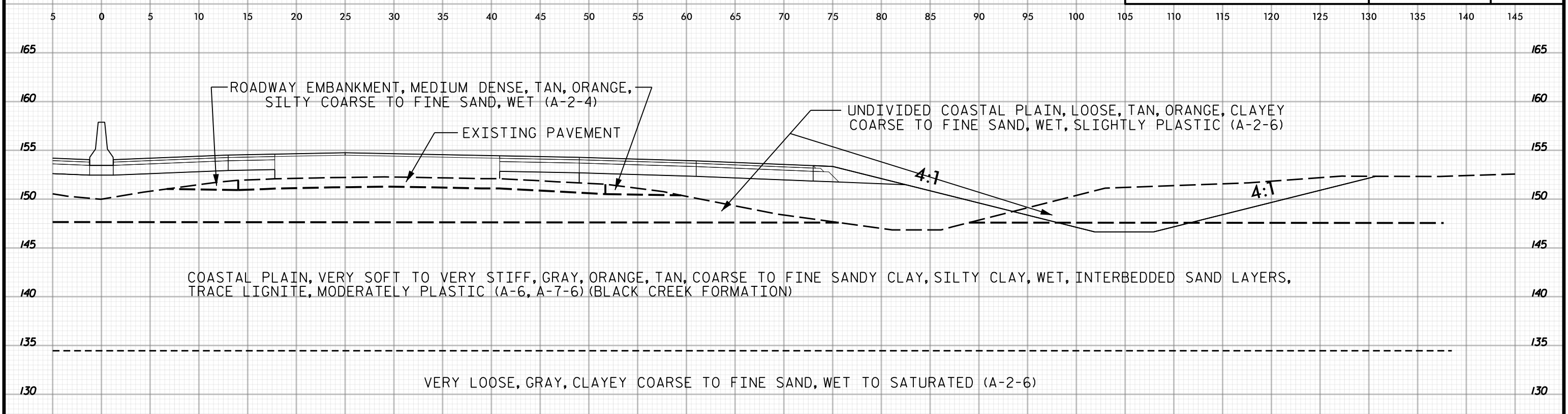
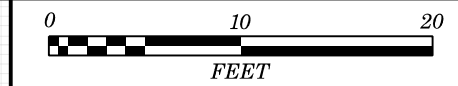

359+00

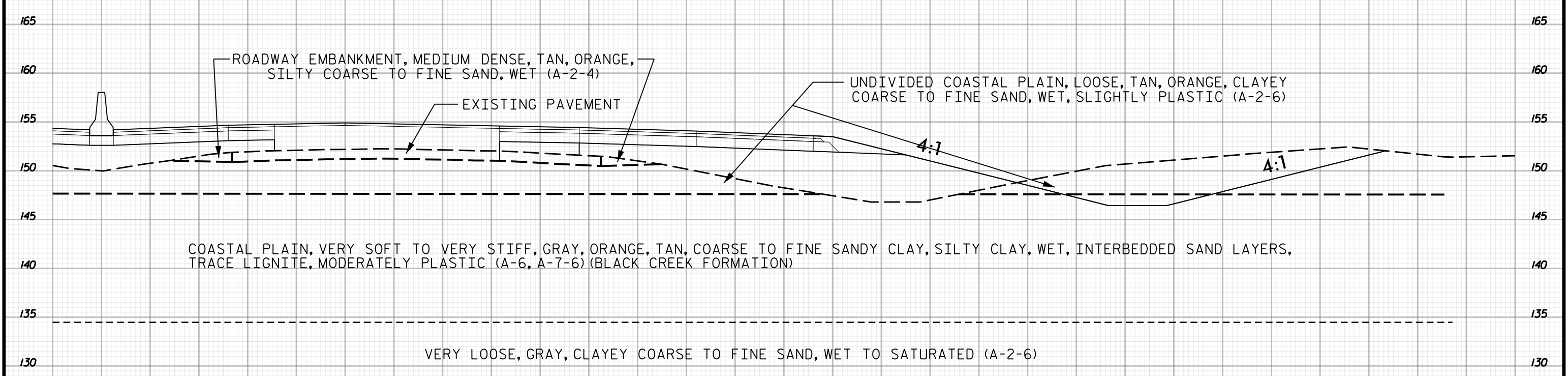

358+50
2 OF 2

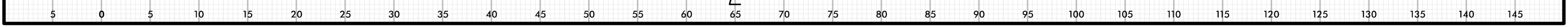
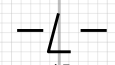



140 135 130 125 120 115 110 105 100 95 90 85 80 75 70 65 60 55 50 45 40 35 30 25 20 15 10 5 0 5

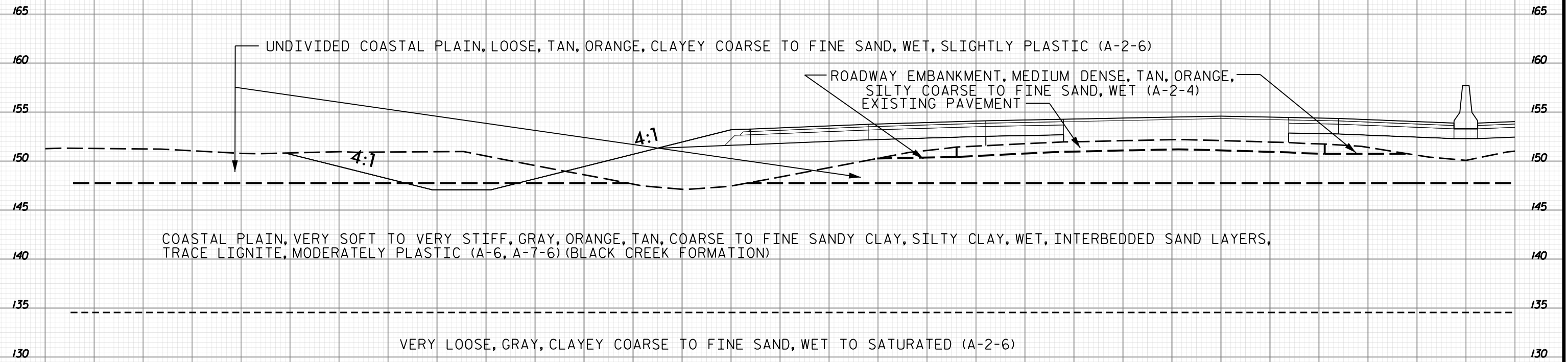

359 + 50
1 OF 2

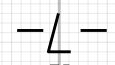

140 135 130 125 120 115 110 105 100 95 90 85 80 75 70 65 60 55 50 45 40 35 30 25 20 15 10 5 0 5



5 0 5 10 15 20 25 30 35 40 45 50 55 60 65 70 75 80 85 90 95 100 105 110 115 120 125 130 135 140 145

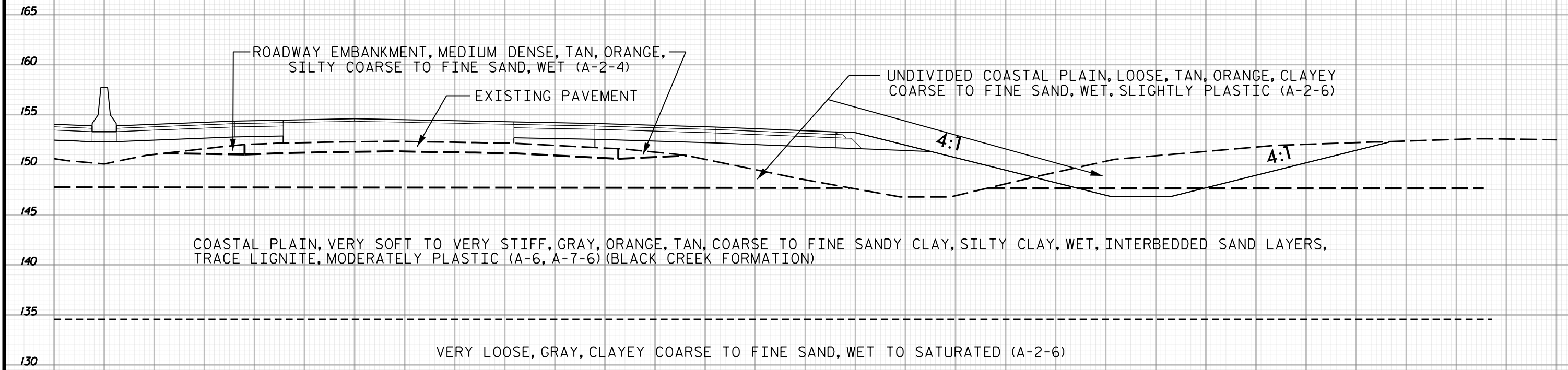

359 + 50
2 OF 2

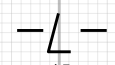

5 0 5 10 15 20 25 30 35 40 45 50 55 60 65 70 75 80 85 90 95 100 105 110 115 120 125 130 135 140 145



140 135 130 125 120 115 110 105 100 95 90 85 80 75 70 65 60 55 50 45 40 35 30 25 20 15 10 5 0 5

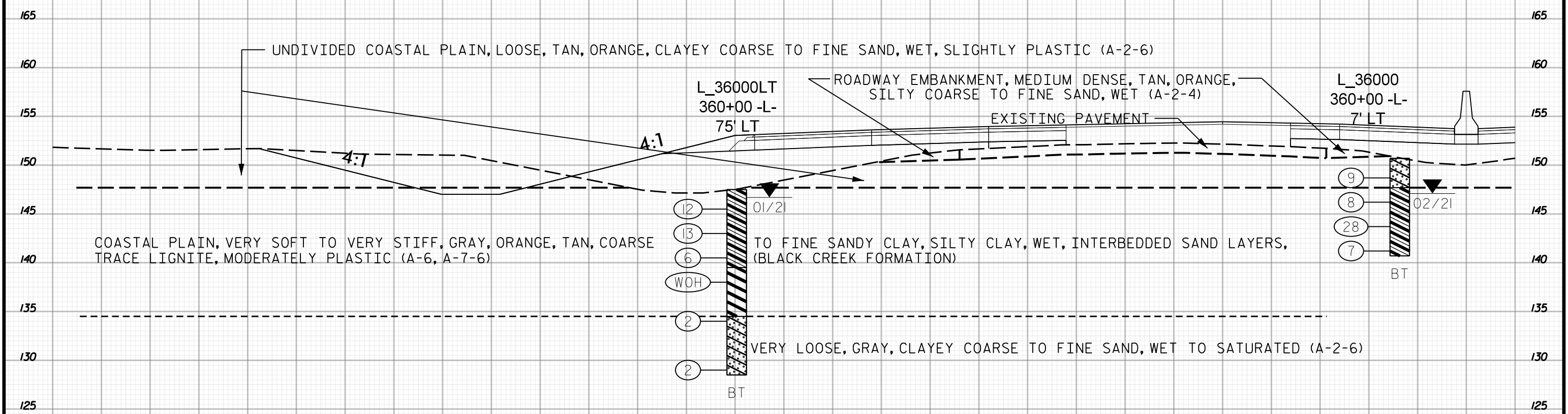

360+00
1 OF 2

-L-

140 135 130 125 120 115 110 105 100 95 90 85 80 75 70 65 60 55 50 45 40 35 30 25 20 15 10 5 0 5



5 0 5 10 15 20 25 30 35 40 45 50 55 60 65 70 75 80 85 90 95 100 105 110 115 120 125 130 135 140 145

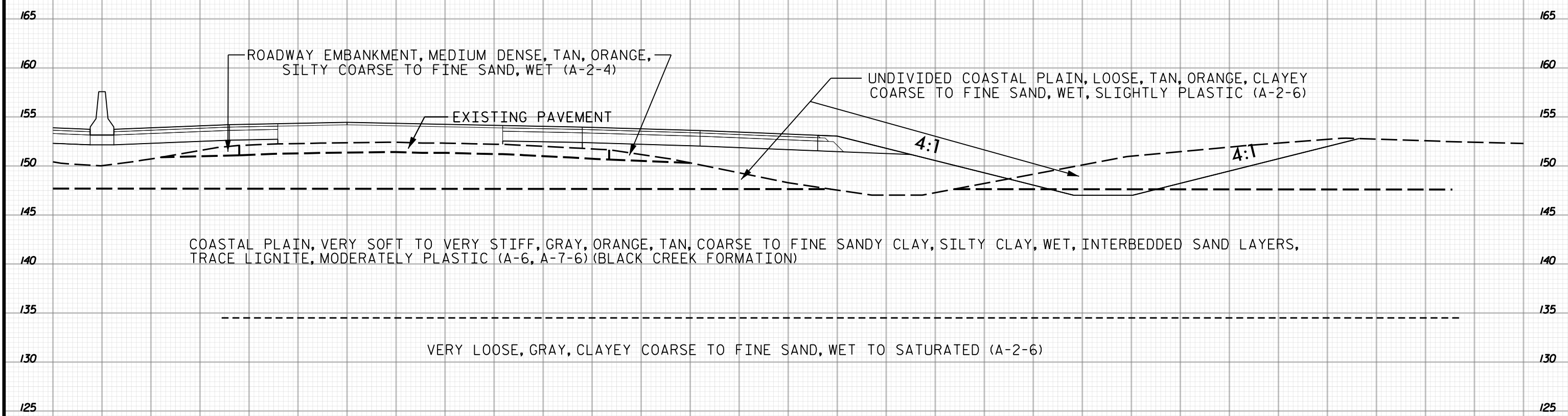

ROADWAY EMBANKMENT, MEDIUM DENSE, TAN, ORANGE, SILTY COARSE TO FINE SAND, WET (A-2-4)

EXISTING PAVEMENT

UNDIVIDED COASTAL PLAIN, LOOSE, TAN, ORANGE, CLAYEY COARSE TO FINE SAND, WET, SLIGHTLY PLASTIC (A-2-6)

COASTAL PLAIN, VERY SOFT TO VERY STIFF, GRAY, ORANGE, TAN, COARSE TO FINE SANDY CLAY, SILTY CLAY, WET, INTERBEDDED SAND LAYERS, TRACE LIGNITE, MODERATELY PLASTIC (A-6, A-7-6) (BLACK CREEK FORMATION)

VERY LOOSE, GRAY, CLAYEY COARSE TO FINE SAND, WET TO SATURATED (A-2-6)

360+00
2 OF 2

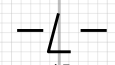

5 0 5 10 15 20 25 30 35 40 45 50 55 60 65 70 75 80 85 90 95 100 105 110 115 120 125 130 135 140 145

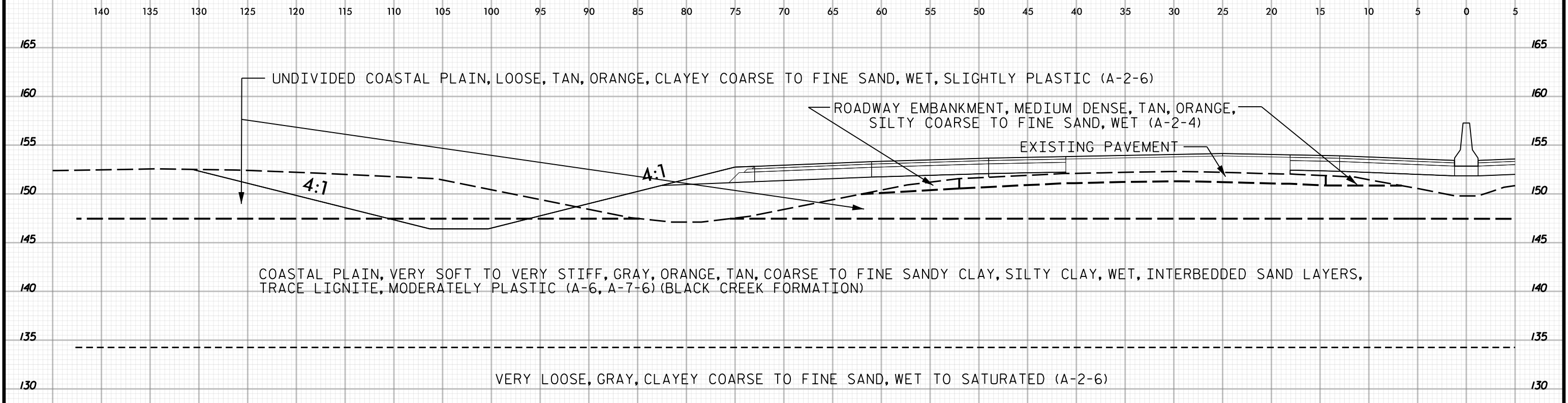

361+00

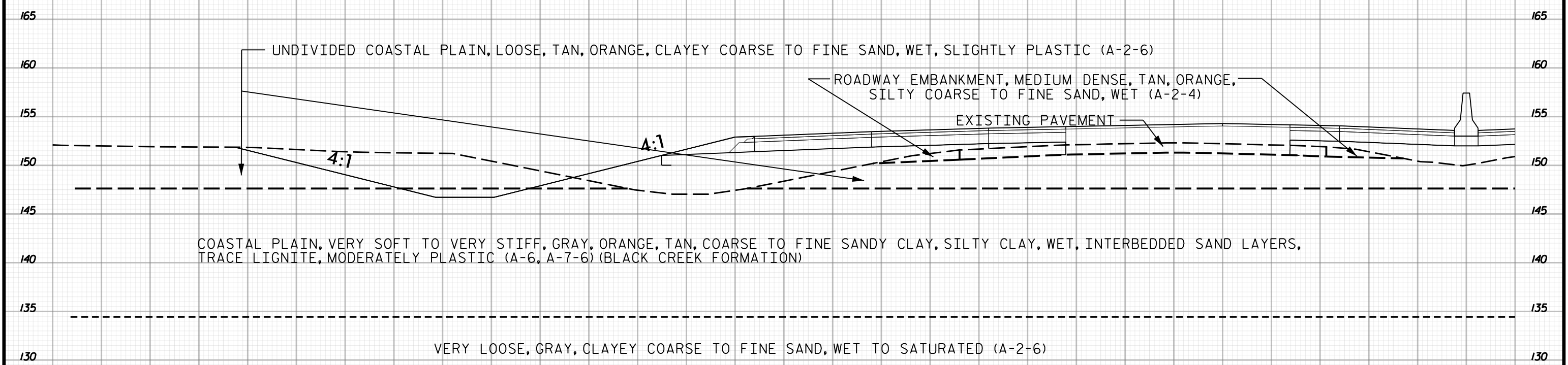

360+50
1 OF 2

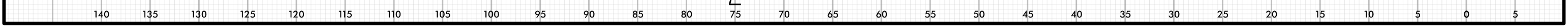
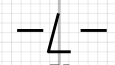

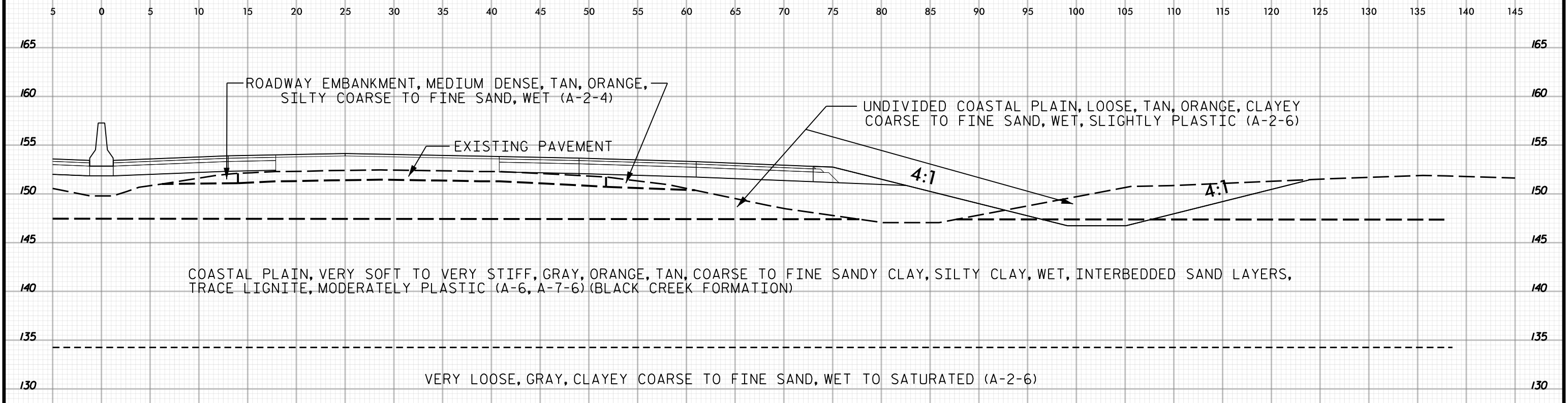

361+00

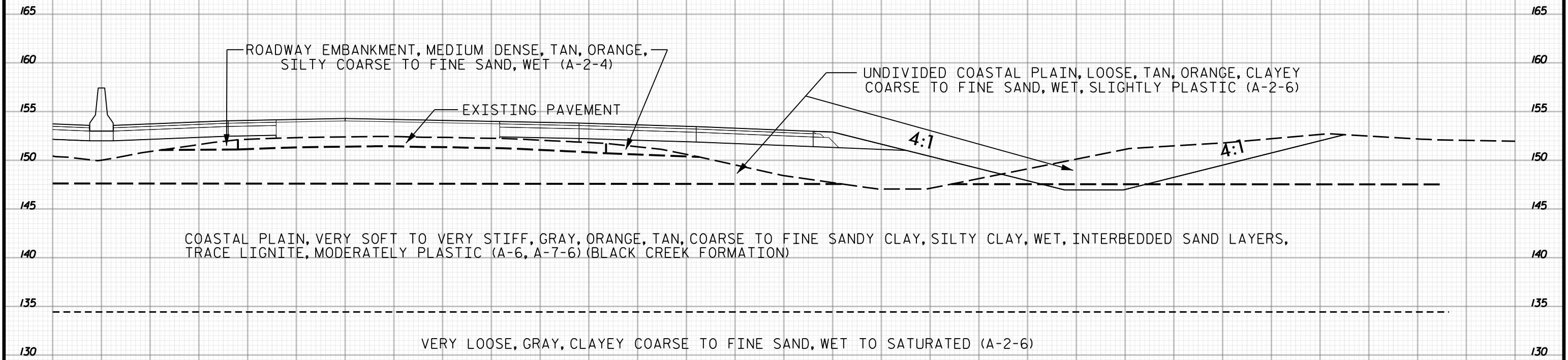

360+50
2 OF 2

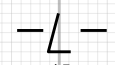



140 135 130 125 120 115 110 105 100 95 90 85 80 75 70 65 60 55 50 45 40 35 30 25 20 15 10 5 0 5

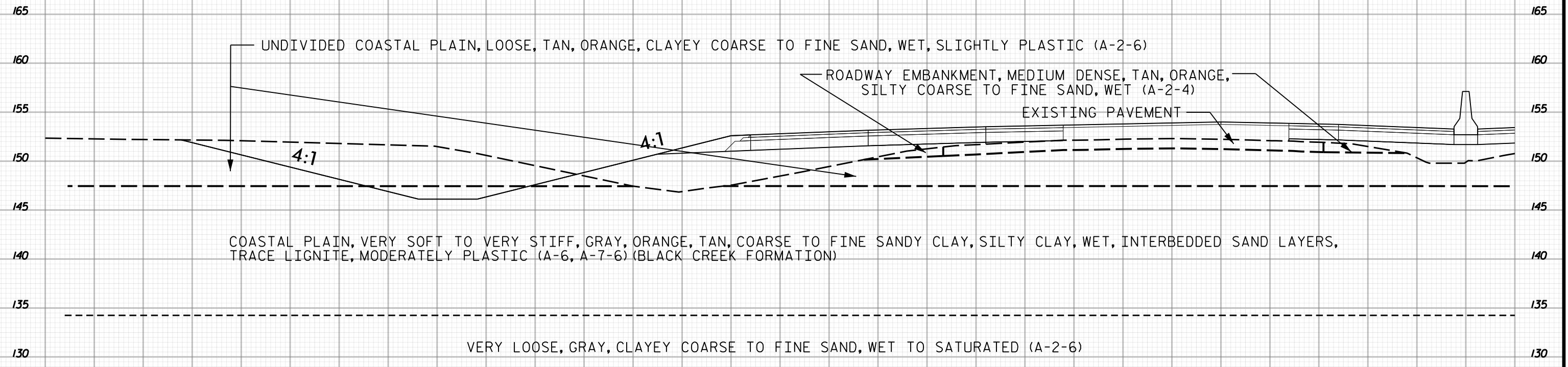

361+50
1 OF 2

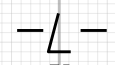

140 135 130 125 120 115 110 105 100 95 90 85 80 75 70 65 60 55 50 45 40 35 30 25 20 15 10 5 0 5

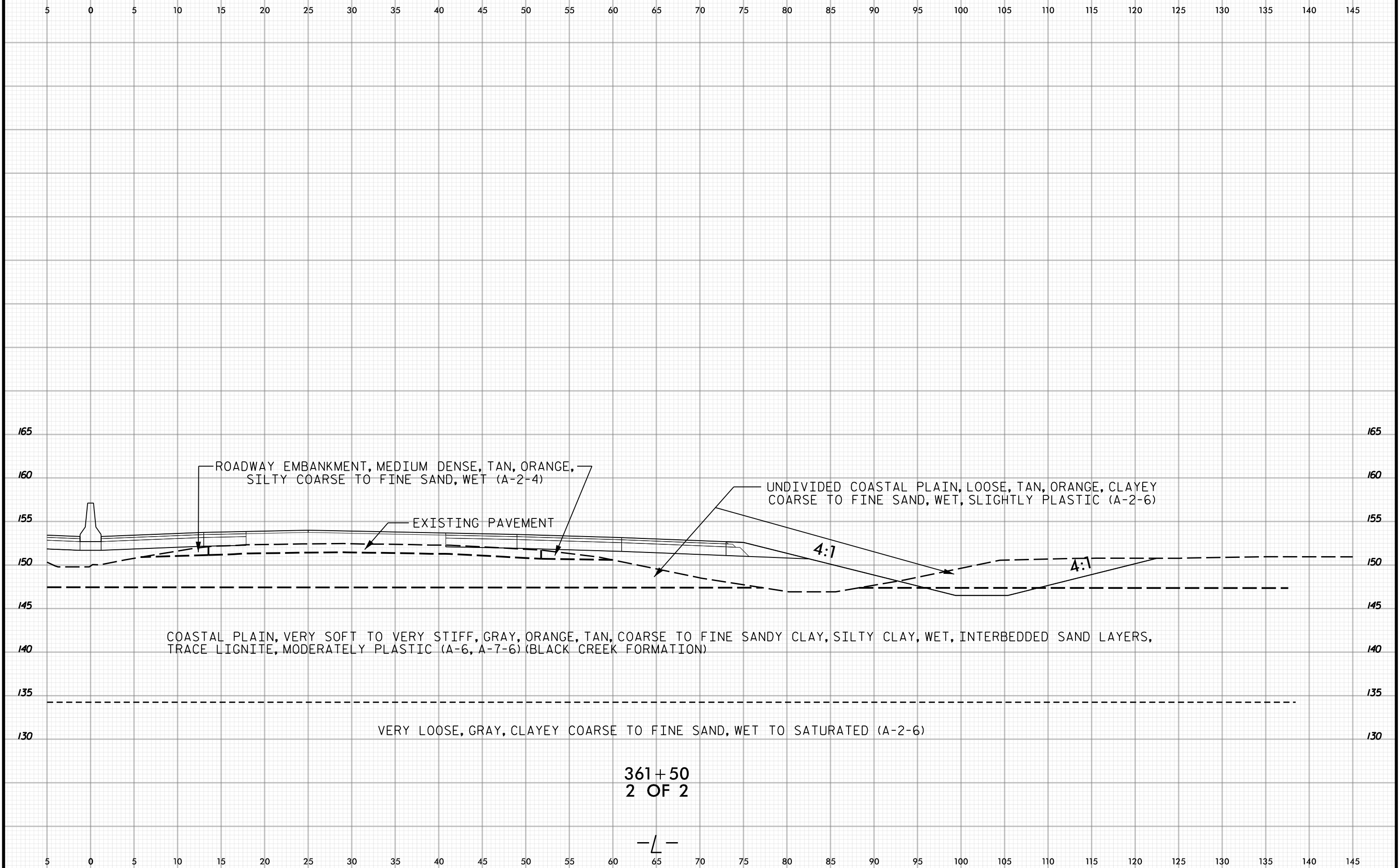

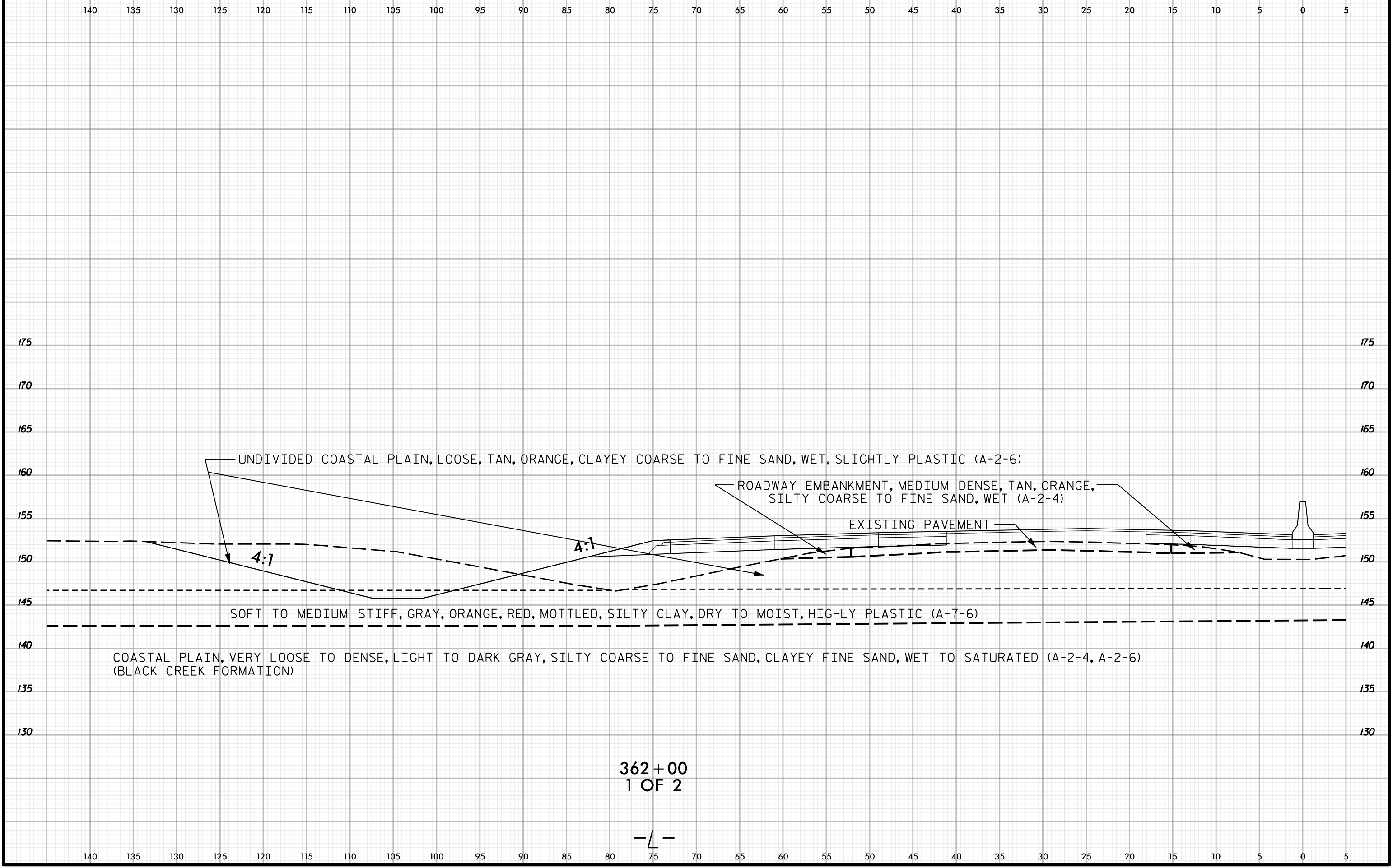



5 0 5 10 15 20 25 30 35 40 45 50 55 60 65 70 75 80 85 90 95 100 105 110 115 120 125 130 135 140 145

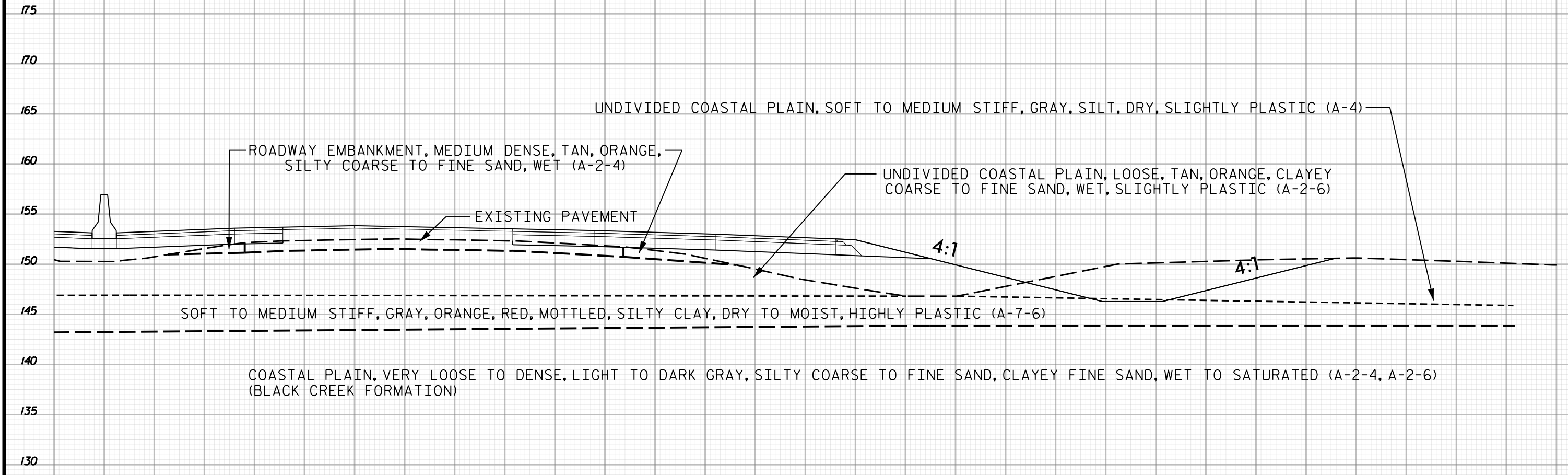

UNDIVIDED COASTAL PLAIN, SOFT TO MEDIUM STIFF, GRAY, SILT, DRY, SLIGHTLY PLASTIC (A-4)

ROADWAY EMBANKMENT, MEDIUM DENSE, TAN, ORANGE, SILTY COARSE TO FINE SAND, WET (A-2-4)

EXISTING PAVEMENT

UNDIVIDED COASTAL PLAIN, LOOSE, TAN, ORANGE, CLAYEY COARSE TO FINE SAND, WET, SLIGHTLY PLASTIC (A-2-6)

4:1

4:1

SOFT TO MEDIUM STIFF, GRAY, ORANGE, RED, MOTTLED, SILTY CLAY, DRY TO MOIST, HIGHLY PLASTIC (A-7-6)

COASTAL PLAIN, VERY LOOSE TO DENSE, LIGHT TO DARK GRAY, SILTY COARSE TO FINE SAND, CLAYEY FINE SAND, WET TO SATURATED (A-2-4, A-2-6) (BLACK CREEK FORMATION)

362+00
2 OF 2

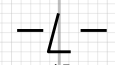

5 0 5 10 15 20 25 30 35 40 45 50 55 60 65 70 75 80 85 90 95 100 105 110 115 120 125 130 135 140 145

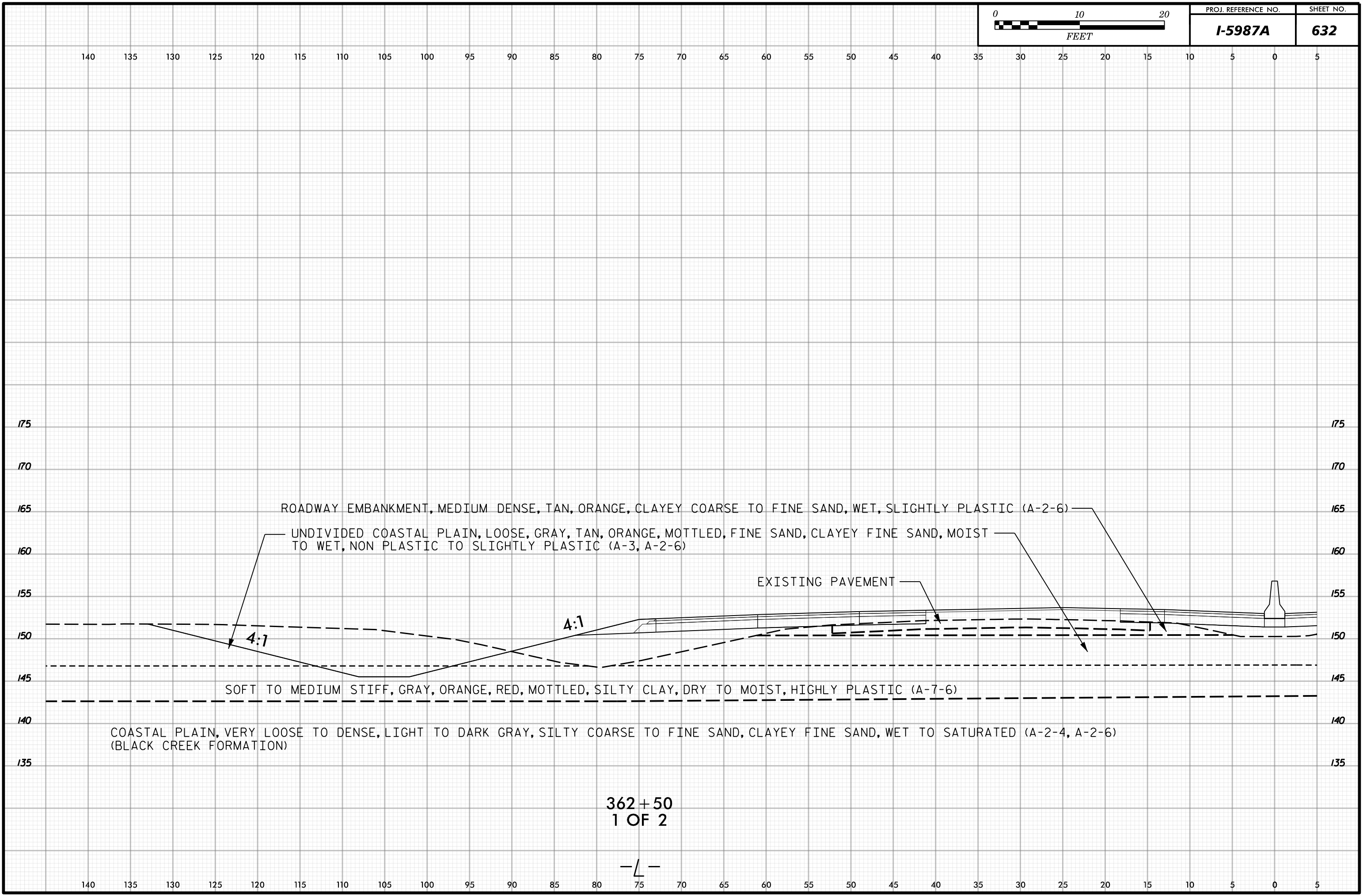

ROADWAY EMBANKMENT, MEDIUM DENSE, TAN, ORANGE, CLAYEY COARSE TO FINE SAND, WET, SLIGHTLY PLASTIC (A-2-6)

UNDIVIDED COASTAL PLAIN, LOOSE, GRAY, TAN, ORANGE, MOTTLED, FINE SAND, CLAYEY FINE SAND, MOIST TO WET, NON PLASTIC TO SLIGHTLY PLASTIC (A-3, A-2-6)

EXISTING PAVEMENT

SOFT TO MEDIUM STIFF, GRAY, ORANGE, RED, MOTTLED, SILTY CLAY, DRY TO MOIST, HIGHLY PLASTIC (A-7-6)

COASTAL PLAIN, VERY LOOSE TO DENSE, LIGHT TO DARK GRAY, SILTY COARSE TO FINE SAND, CLAYEY FINE SAND, WET TO SATURATED (A-2-4, A-2-6) (BLACK CREEK FORMATION)

4:1

4:1

362+50
1 OF 2

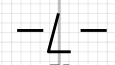



5 0 5 10 15 20 25 30 35 40 45 50 55 60 65 70 75 80 85 90 95 100 105 110 115 120 125 130 135 140 145

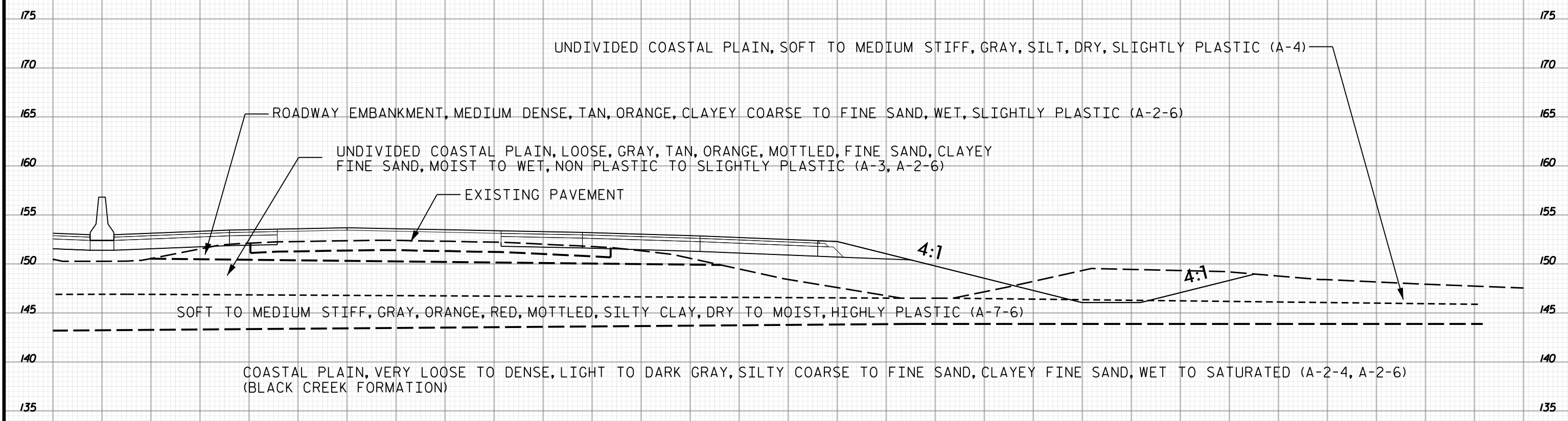

362+50
2 OF 2

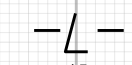

5 0 5 10 15 20 25 30 35 40 45 50 55 60 65 70 75 80 85 90 95 100 105 110 115 120 125 130 135 140 145

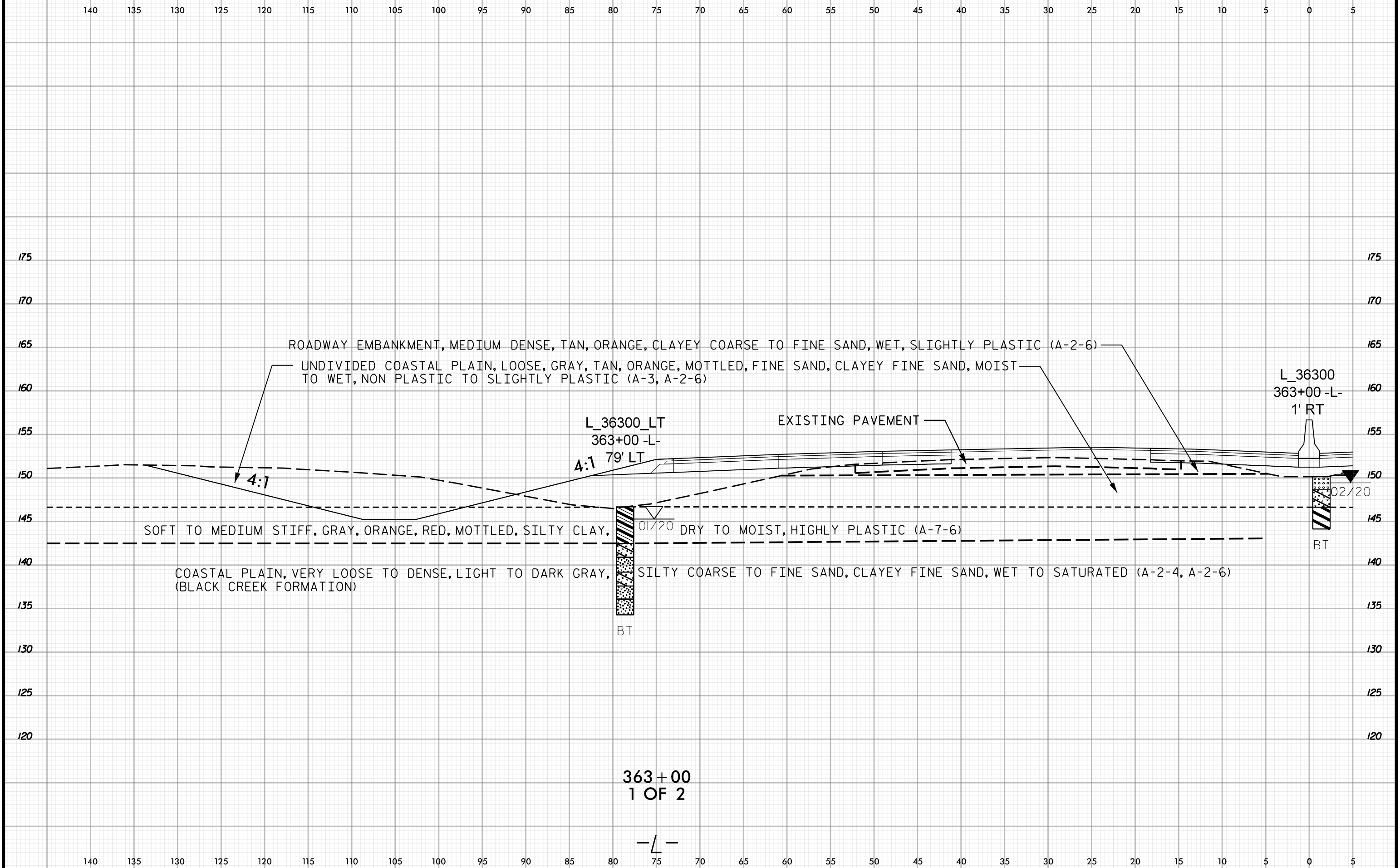

363+00
1 OF 2

-L-

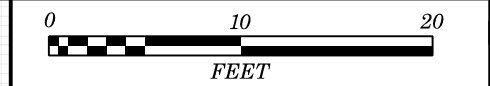

5 0 5 10 15 20 25 30 35 40 45 50 55 60 65 70 75 80 85 90 95 100 105 110 115 120 125 130 135 140 145

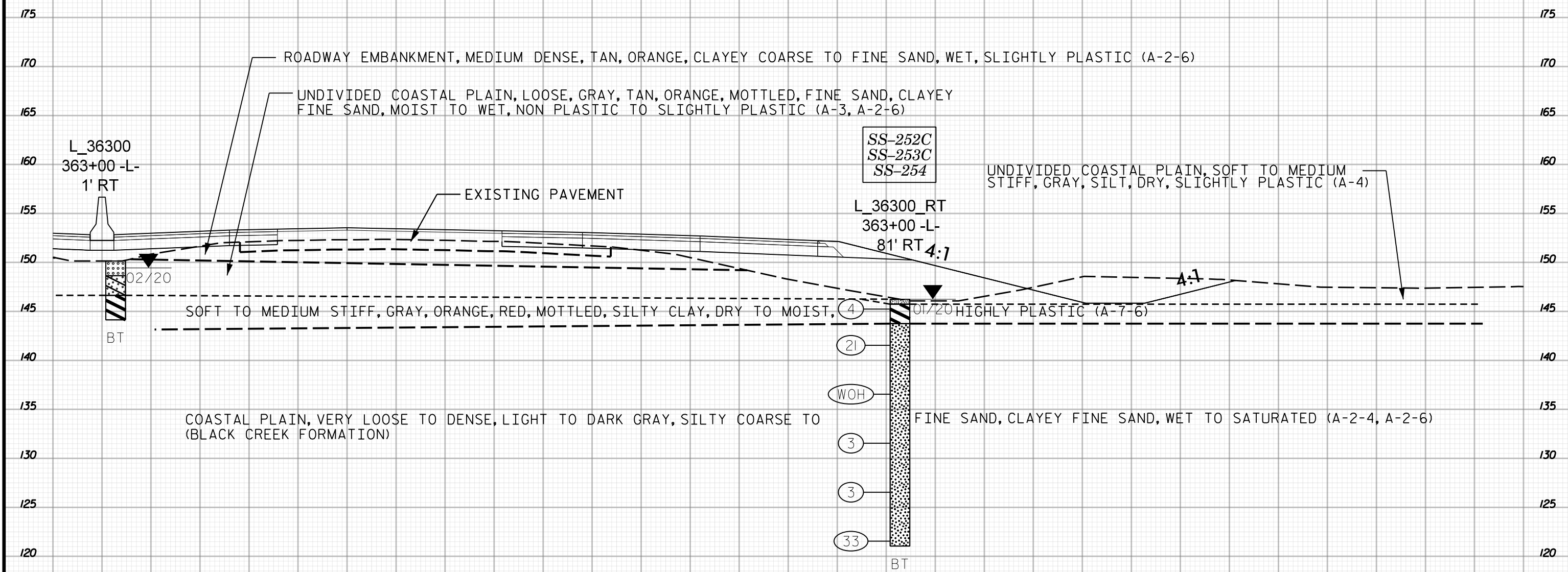

363+00
2 OF 2

-L-

5 0 5 10 15 20 25 30 35 40 45 50 55 60 65 70 75 80 85 90 95 100 105 110 115 120 125 130 135 140 145



140 135 130 125 120 115 110 105 100 95 90 85 80 75 70 65 60 55 50 45 40 35 30 25 20 15 10 5 0 5

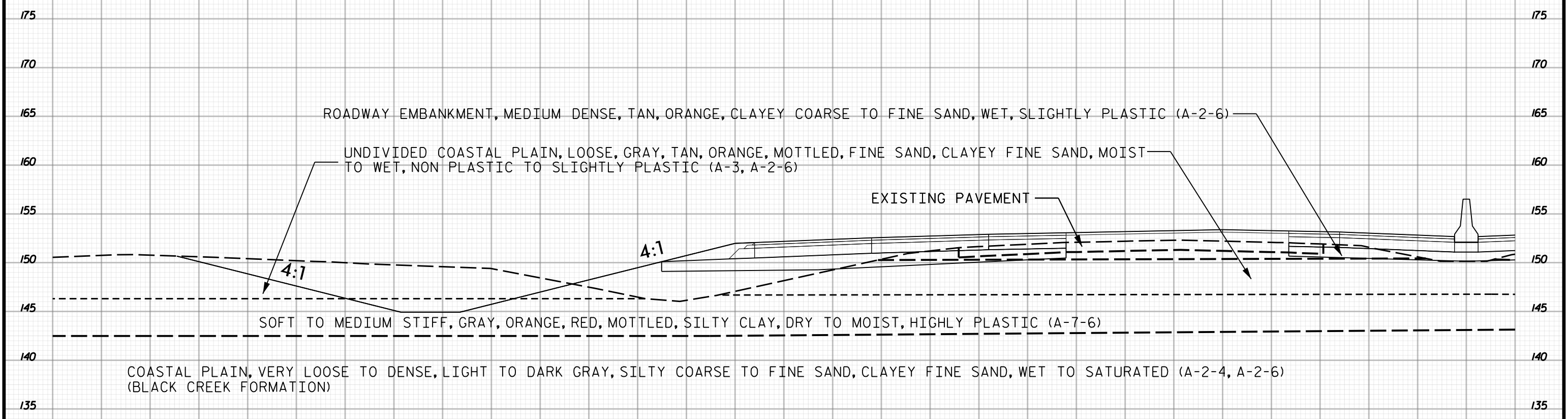

363 + 50
1 OF 2

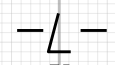

140 135 130 125 120 115 110 105 100 95 90 85 80 75 70 65 60 55 50 45 40 35 30 25 20 15 10 5 0 5



5 0 5 10 15 20 25 30 35 40 45 50 55 60 65 70 75 80 85 90 95 100 105 110 115 120 125 130 135 140 145

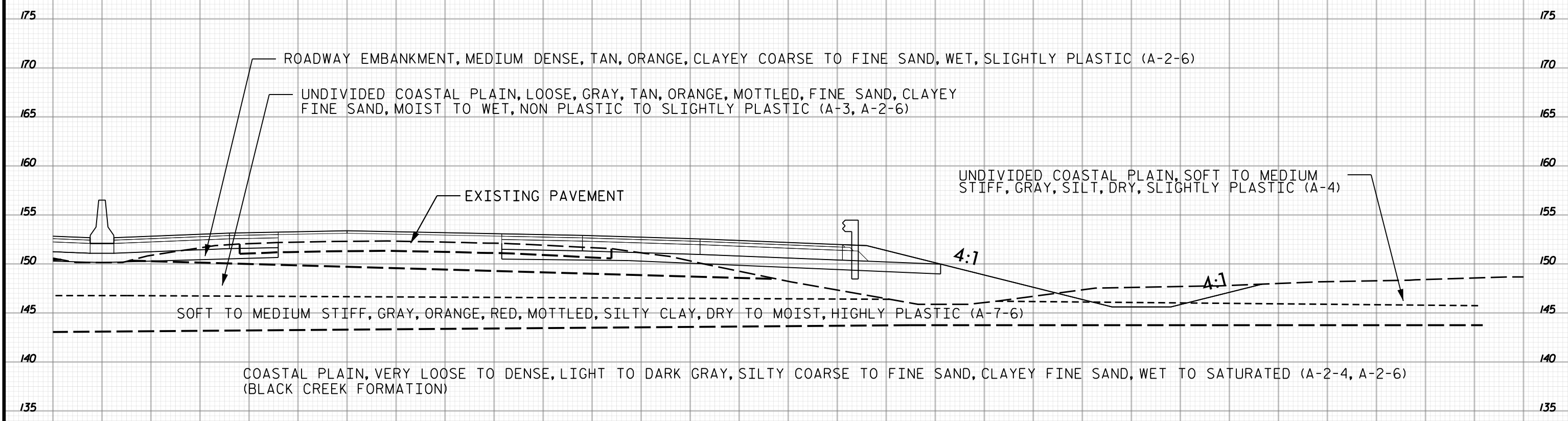

363+50
2 OF 2

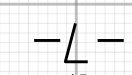

5 0 5 10 15 20 25 30 35 40 45 50 55 60 65 70 75 80 85 90 95 100 105 110 115 120 125 130 135 140 145

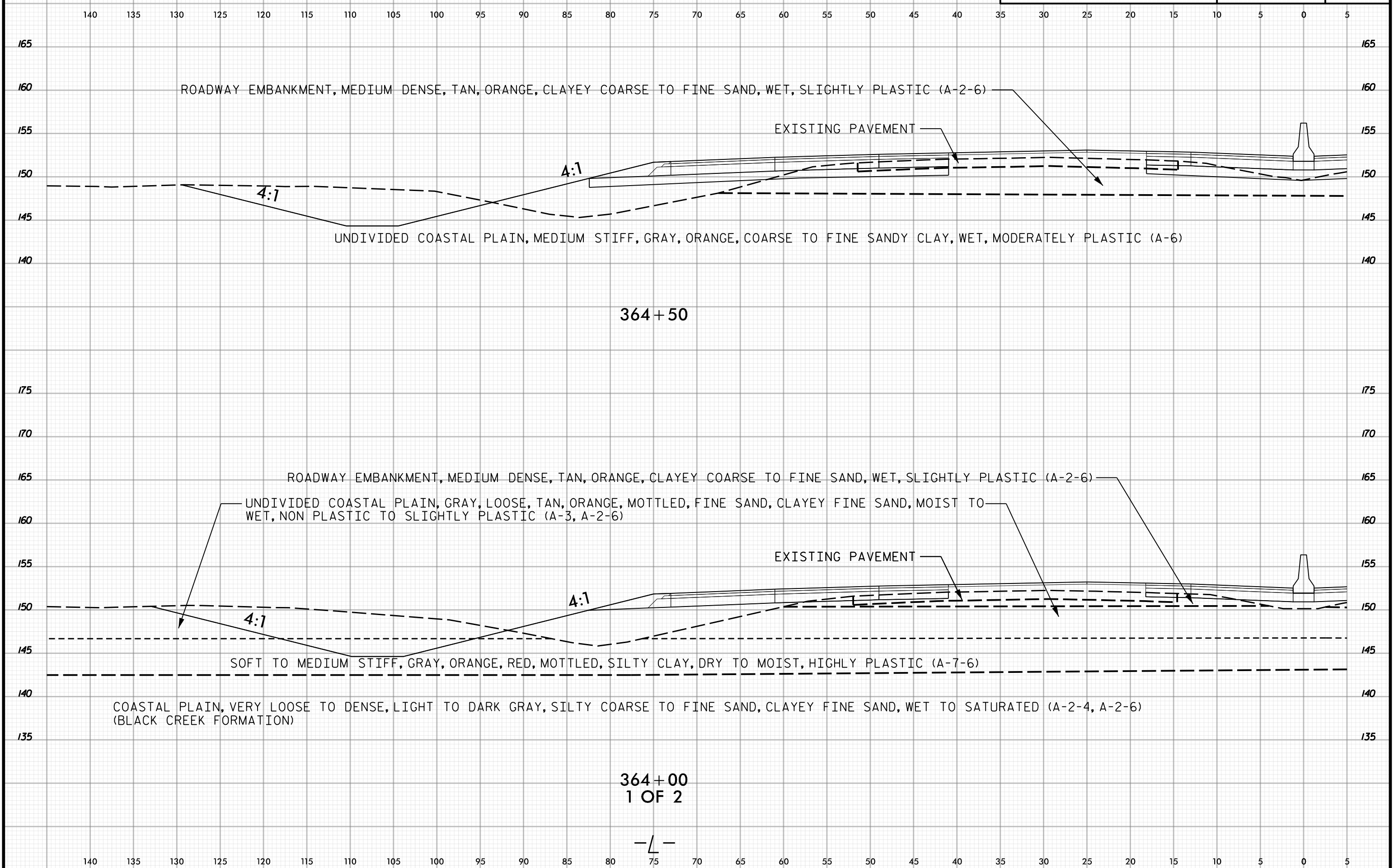

364+00
1 OF 2

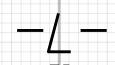

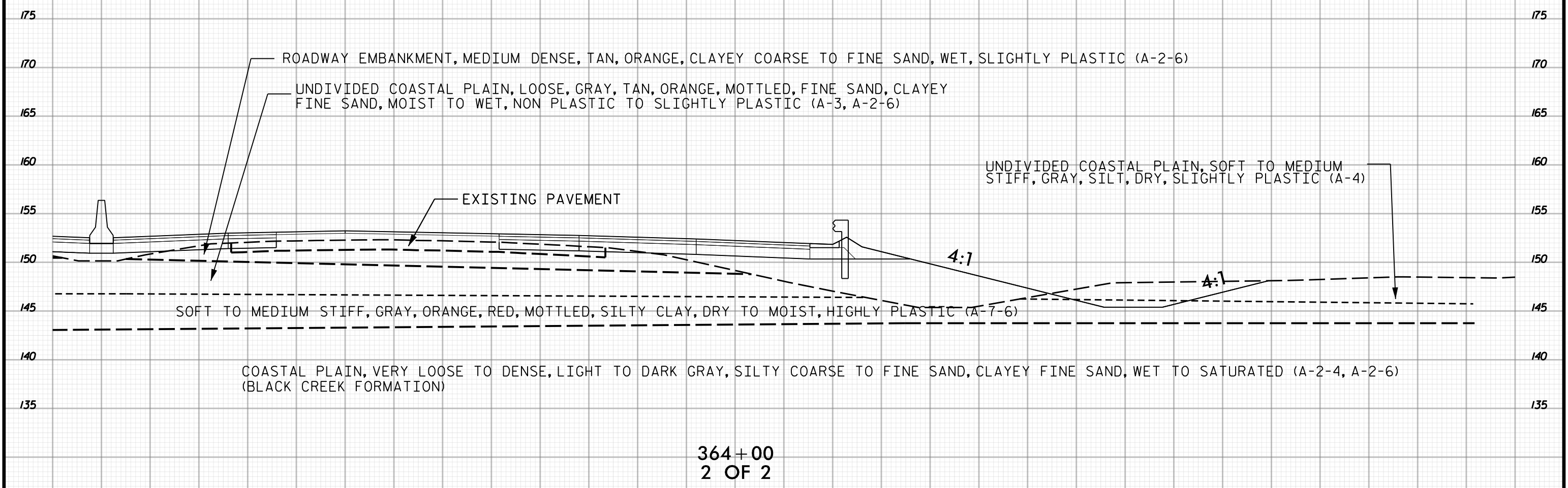
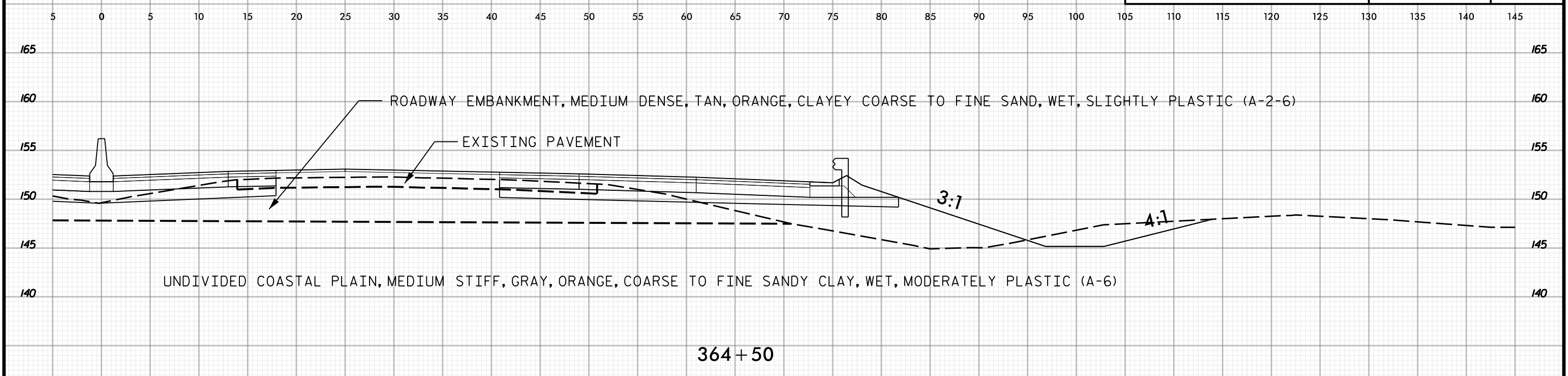



PROJ. REFERENCE NO.	SHEET NO.
I-5987A	640

140 135 130 125 120 115 110 105 100 95 90 85 80 75 70 65 60 55 50 45 40 35 30 25 20 15 10 5 0 5

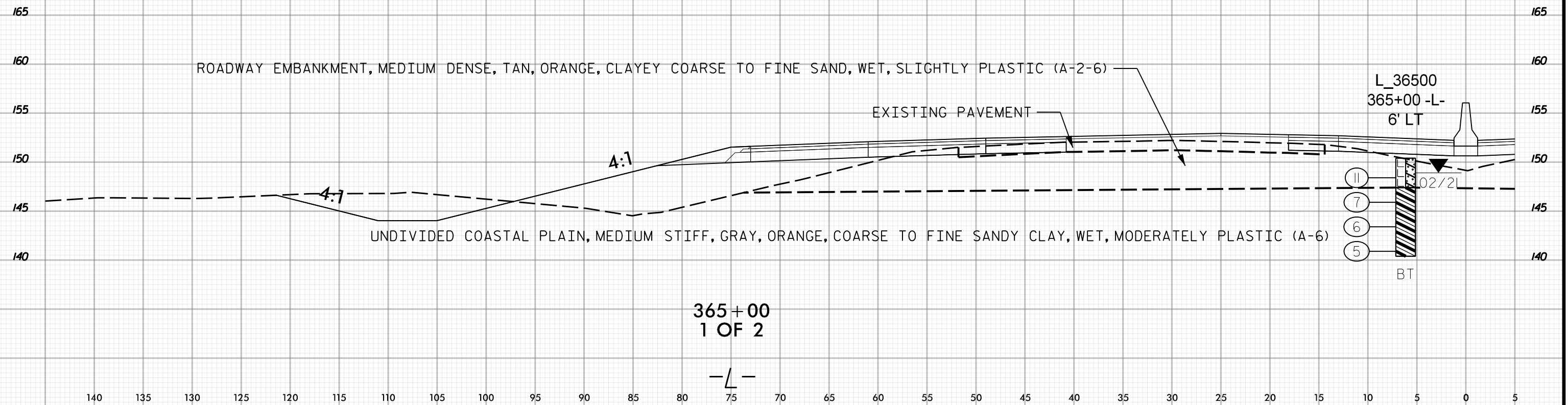

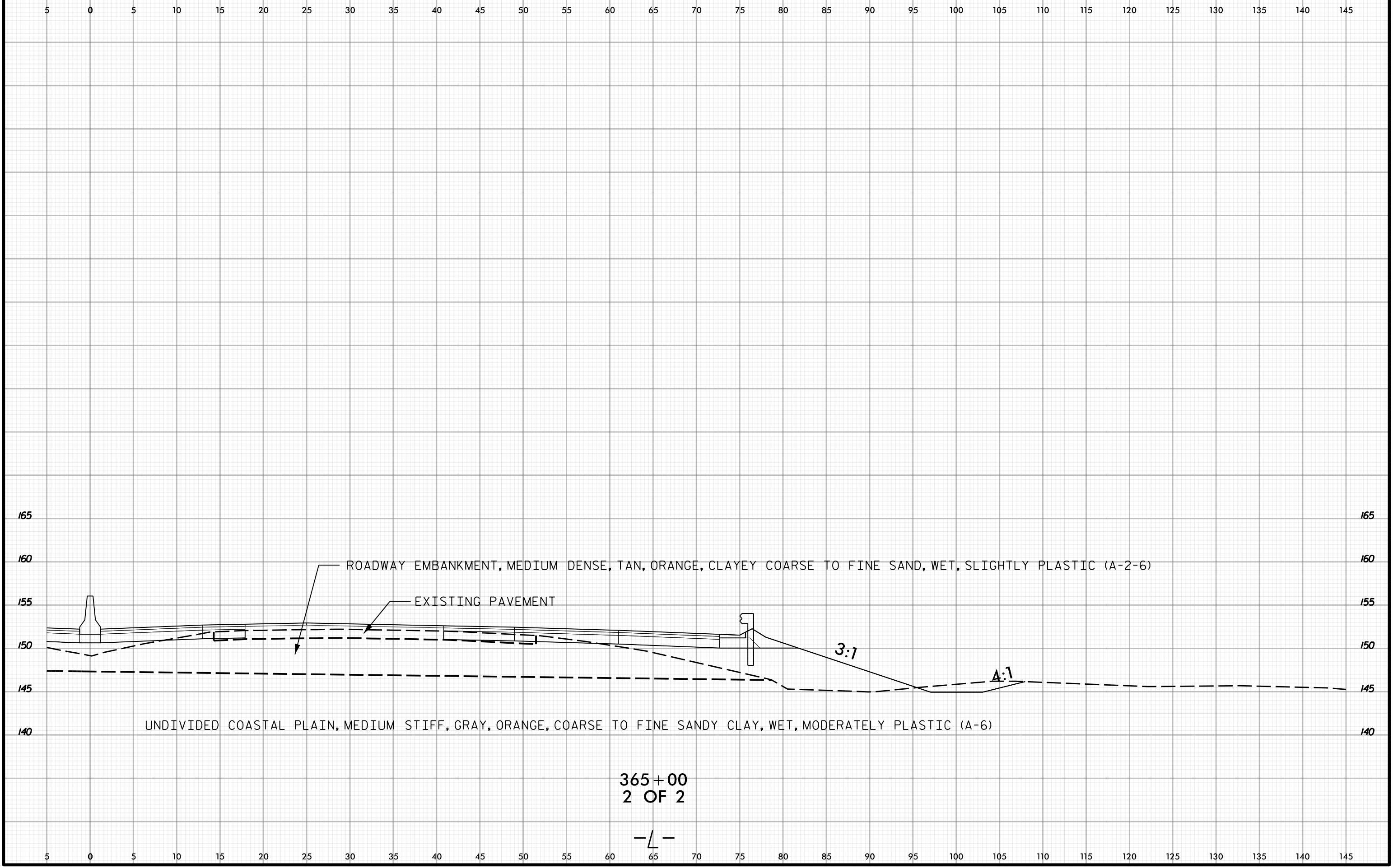

365+00
2 OF 2

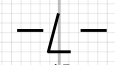

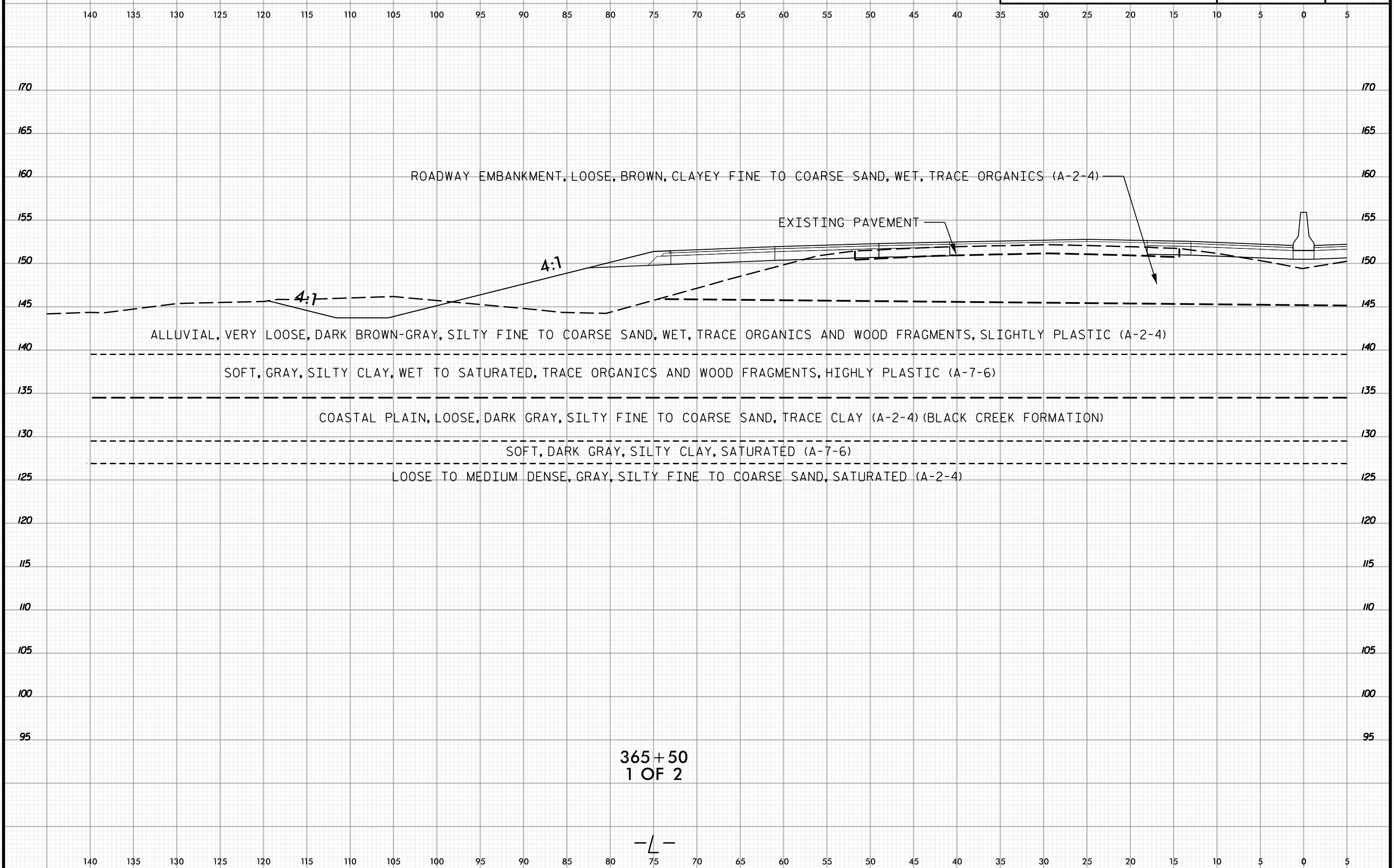

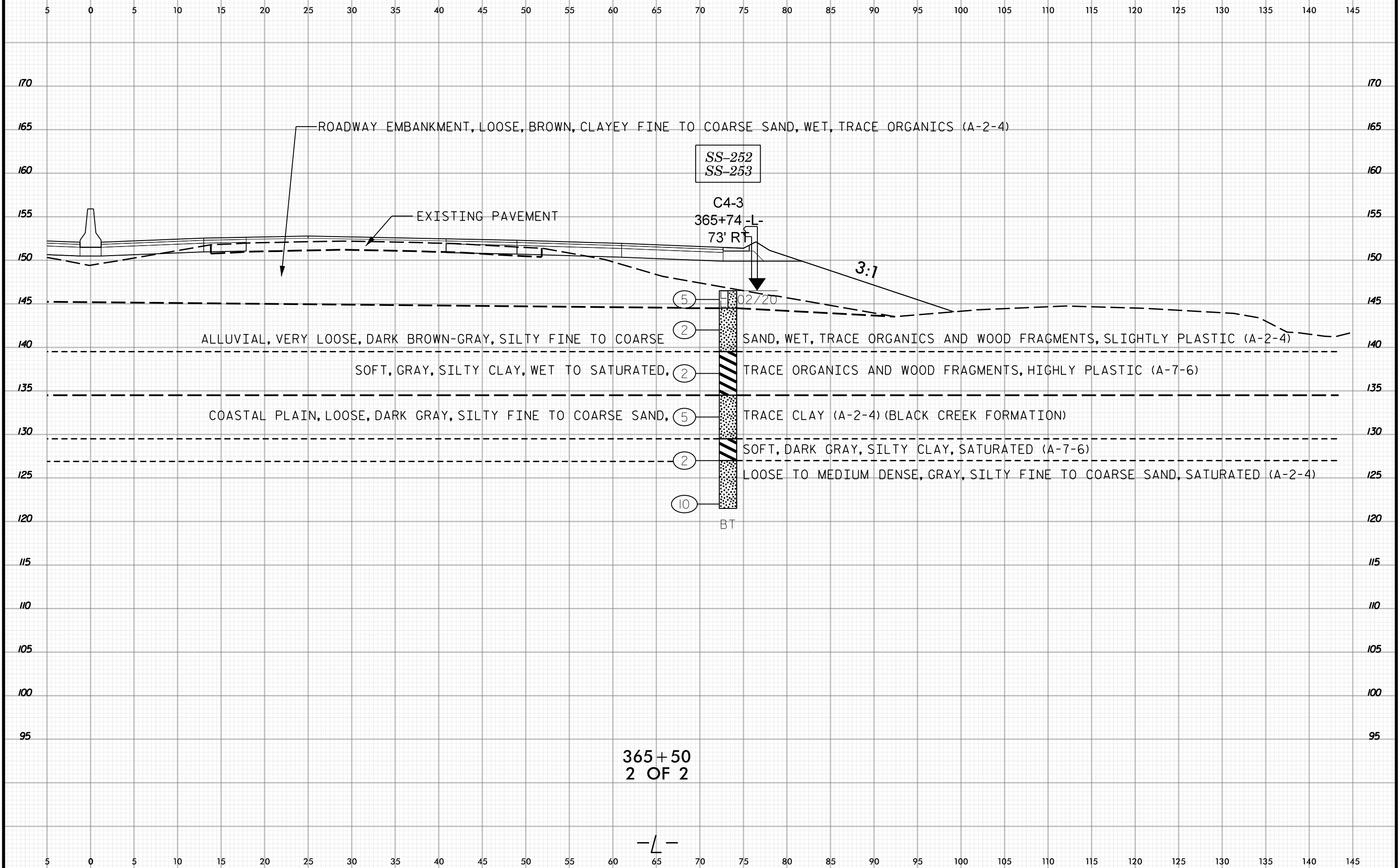
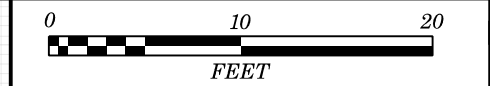

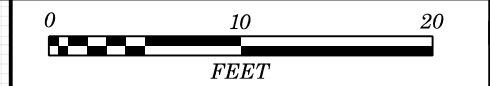

140 135 130 125 120 115 110 105 100 95 90 85 80 75 70 65 60 55 50 45 40 35 30 25 20 15 10 5 0 5

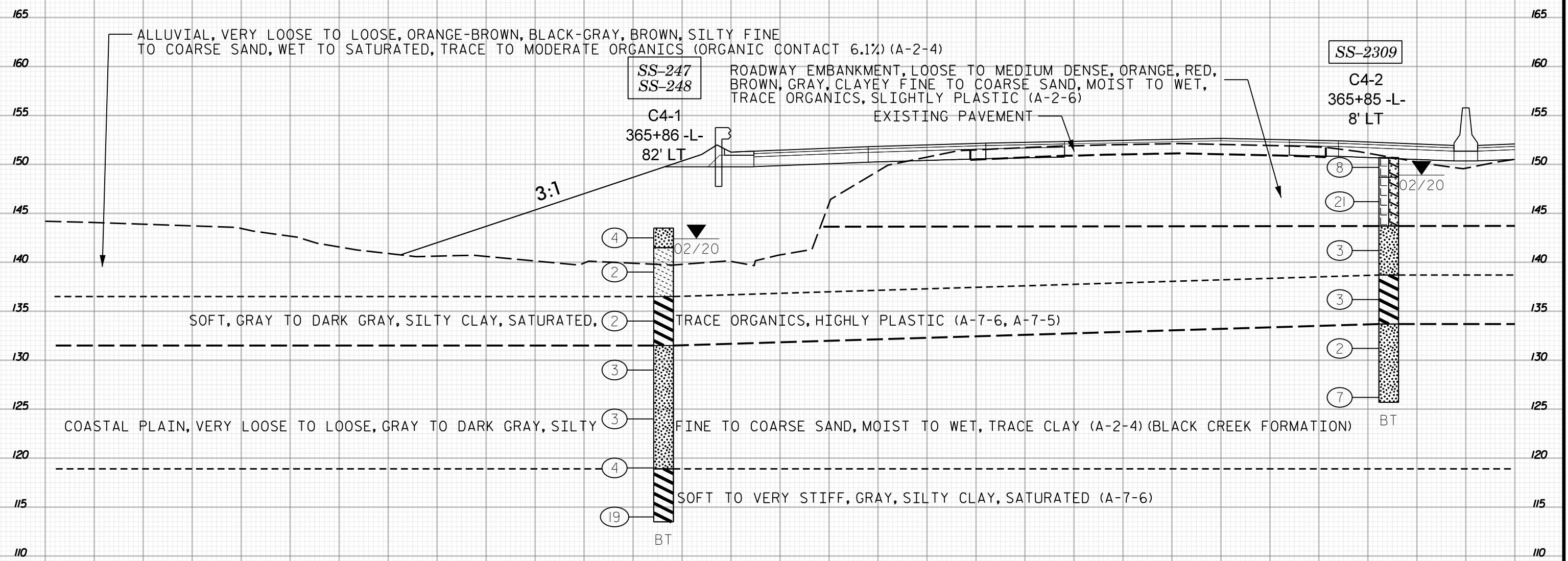

366+00
1 OF 2

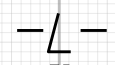

140 135 130 125 120 115 110 105 100 95 90 85 80 75 70 65 60 55 50 45 40 35 30 25 20 15 10 5 0 5



5 0 5 10 15 20 25 30 35 40 45 50 55 60 65 70 75 80 85 90 95 100 105 110 115 120 125 130 135 140 145

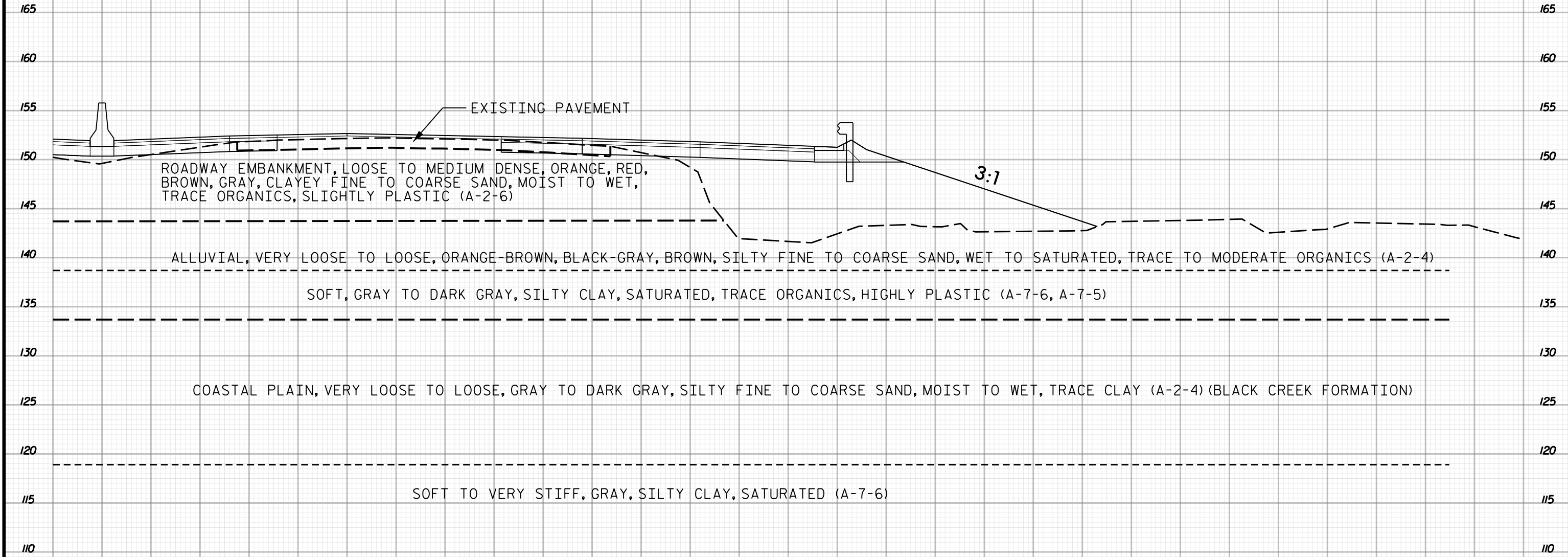

366+00
2 OF 2

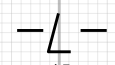

5 0 5 10 15 20 25 30 35 40 45 50 55 60 65 70 75 80 85 90 95 100 105 110 115 120 125 130 135 140 145

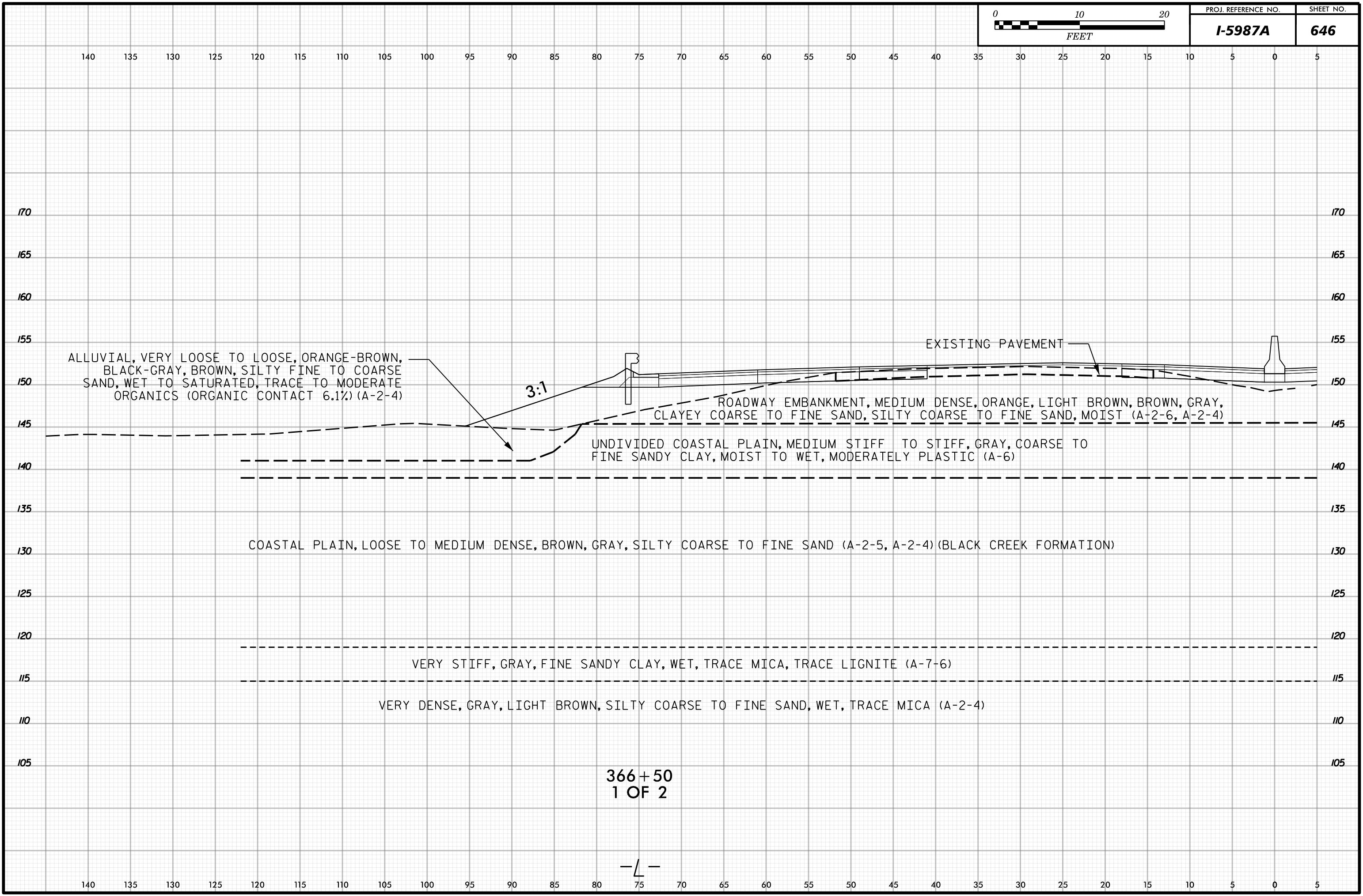

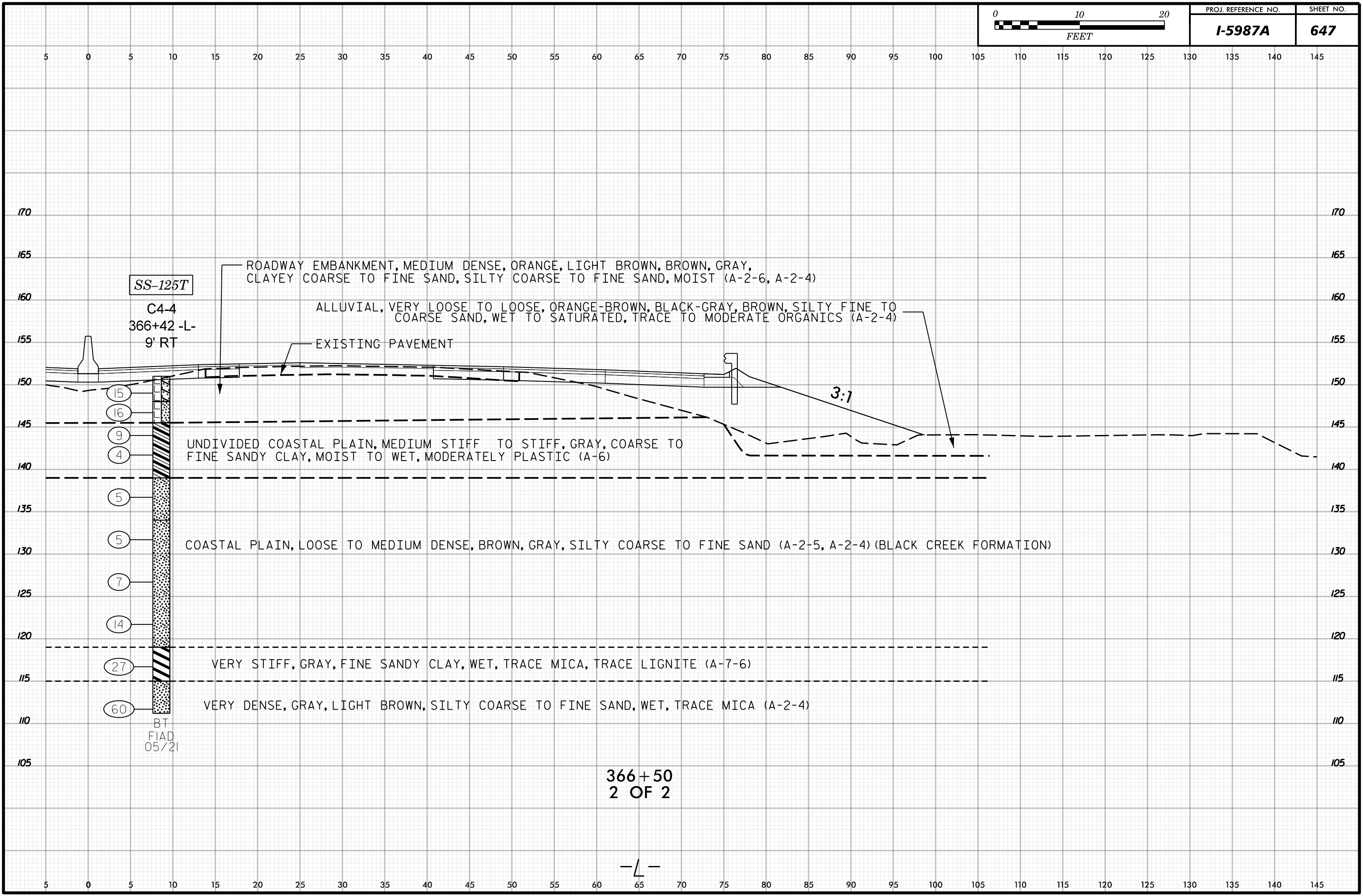

SS-125T

C4-4
366+42 -L-
9' RT

ROADWAY EMBANKMENT, MEDIUM DENSE, ORANGE, LIGHT BROWN, BROWN, GRAY,
CLAYEY COARSE TO FINE SAND, SILTY COARSE TO FINE SAND, MOIST (A-2-6, A-2-4)

ALLUVIAL, VERY LOOSE TO LOOSE, ORANGE-BROWN, BLACK-GRAY, BROWN, SILTY FINE TO
COARSE SAND, WET TO SATURATED, TRACE TO MODERATE ORGANICS (A-2-4)

EXISTING PAVEMENT

3:1

UNDIVIDED COASTAL PLAIN, MEDIUM STIFF TO STIFF, GRAY, COARSE TO
FINE SANDY CLAY, MOIST TO WET, MODERATELY PLASTIC (A-6)

COASTAL PLAIN, LOOSE TO MEDIUM DENSE, BROWN, GRAY, SILTY COARSE TO FINE SAND (A-2-5, A-2-4) (BLACK CREEK FORMATION)

VERY STIFF, GRAY, FINE SANDY CLAY, WET, TRACE MICA, TRACE LIGNITE (A-7-6)

VERY DENSE, GRAY, LIGHT BROWN, SILTY COARSE TO FINE SAND, WET, TRACE MICA (A-2-4)

BT
FIAD
05/21

366+50
2 OF 2

-L-

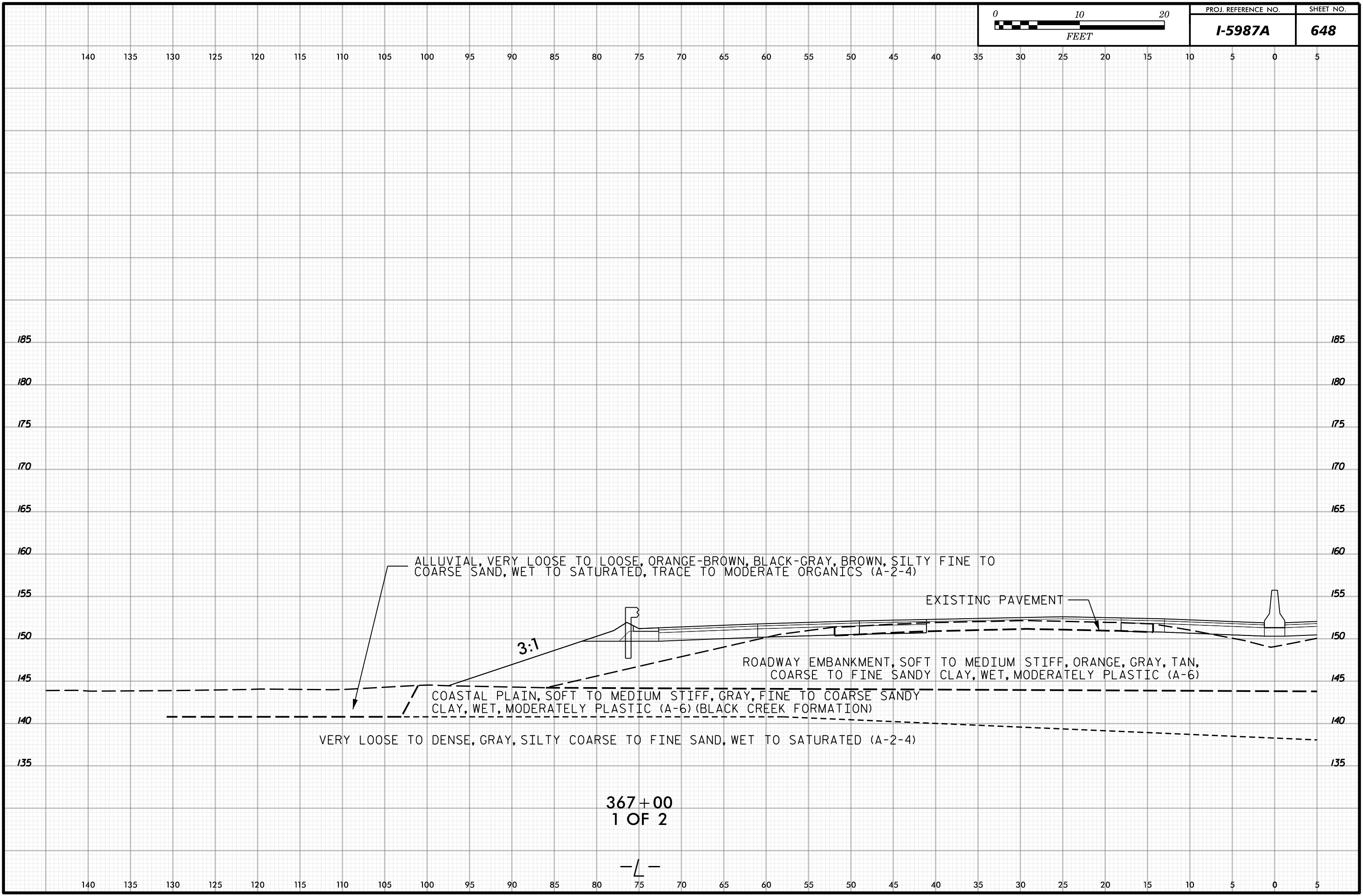

367+00
1 OF 2

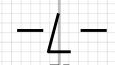

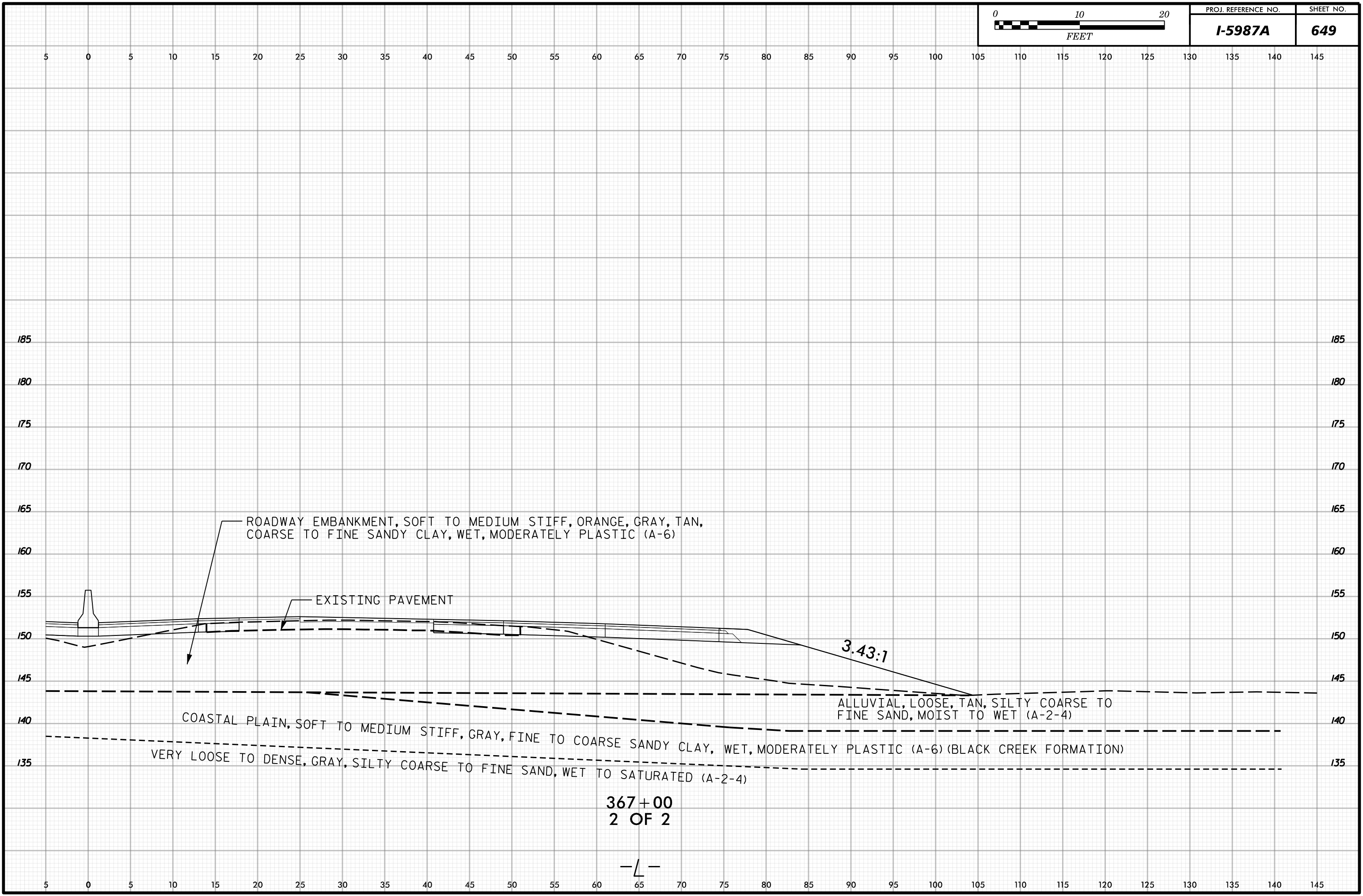

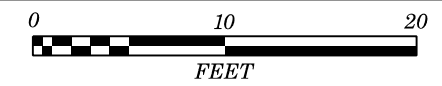

140 135 130 125 120 115 110 105 100 95 90 85 80 75 70 65 60 55 50 45 40 35 30 25 20 15 10 5 0 5

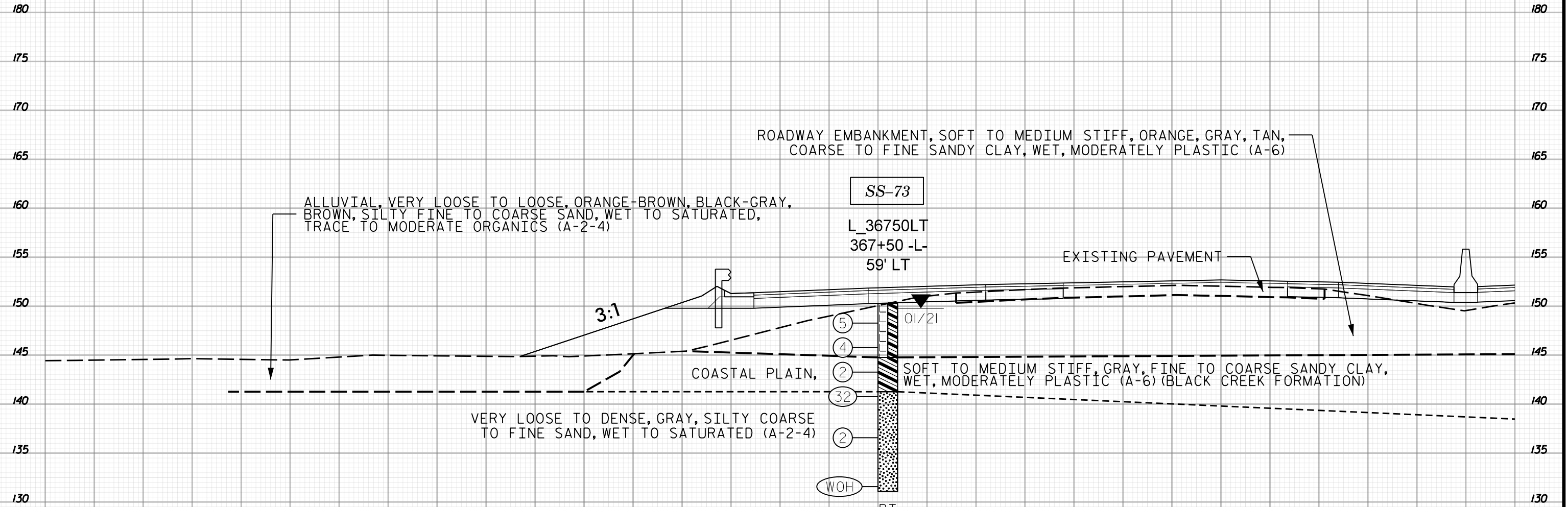

ALLUVIAL, VERY LOOSE TO LOOSE, ORANGE-BROWN, BLACK-GRAY, BROWN, SILTY FINE TO COARSE SAND, WET TO SATURATED, TRACE TO MODERATE ORGANICS (A-2-4)

ROADWAY EMBANKMENT, SOFT TO MEDIUM STIFF, ORANGE, GRAY, TAN, COARSE TO FINE SANDY CLAY, WET, MODERATELY PLASTIC (A-6)

SS-73

L_36750LT
367+50 -L-
59' LT

EXISTING PAVEMENT

COASTAL PLAIN,

SOFT TO MEDIUM STIFF, GRAY, FINE TO COARSE SANDY CLAY, WET, MODERATELY PLASTIC (A-6) (BLACK CREEK FORMATION)

VERY LOOSE TO DENSE, GRAY, SILTY COARSE TO FINE SAND, WET TO SATURATED (A-2-4)

WOH

BT

367+50
1 OF 2

-L-

140 135 130 125 120 115 110 105 100 95 90 85 80 75 70 65 60 55 50 45 40 35 30 25 20 15 10 5 0 5



5 0 5 10 15 20 25 30 35 40 45 50 55 60 65 70 75 80 85 90 95 100 105 110 115 120 125 130 135 140 145

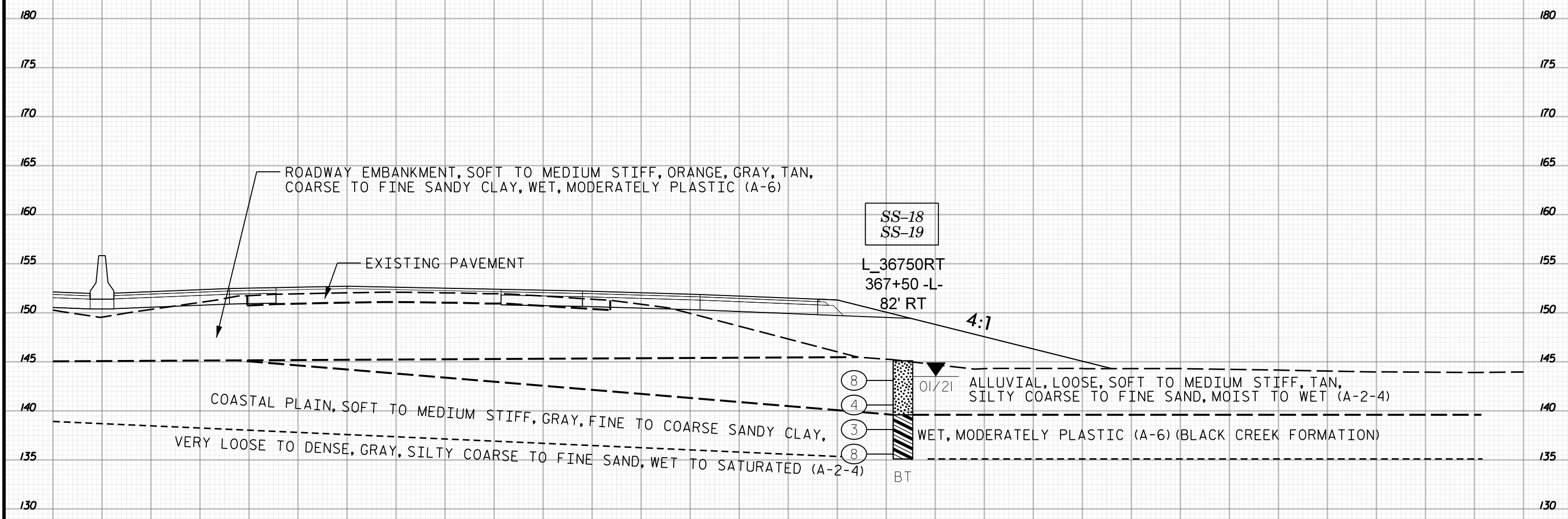

367+50
2 OF 2

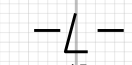

5 0 5 10 15 20 25 30 35 40 45 50 55 60 65 70 75 80 85 90 95 100 105 110 115 120 125 130 135 140 145



140 135 130 125 120 115 110 105 100 95 90 85 80 75 70 65 60 55 50 45 40 35 30 25 20 15 10 5 0 5

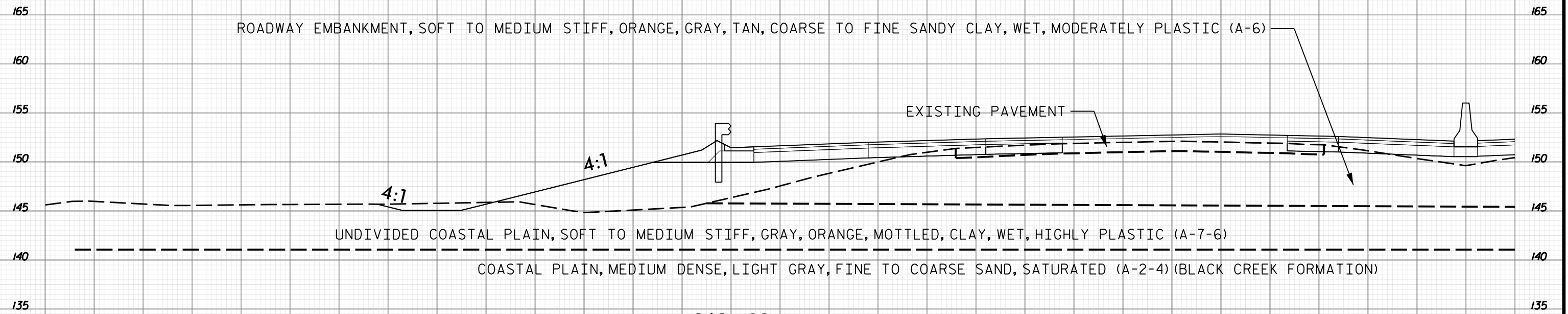

368+00
1 OF 2

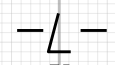

140 135 130 125 120 115 110 105 100 95 90 85 80 75 70 65 60 55 50 45 40 35 30 25 20 15 10 5 0 5

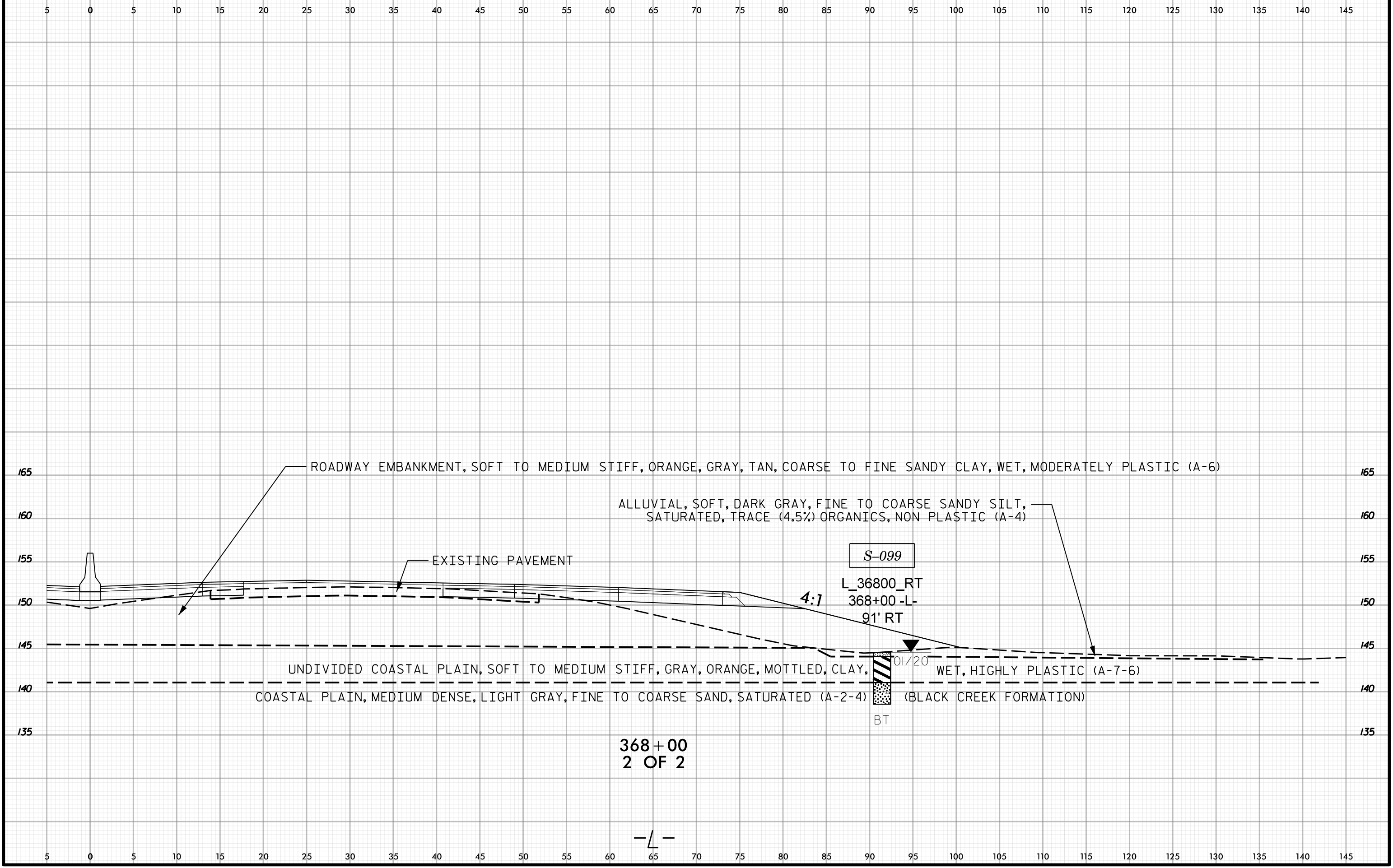
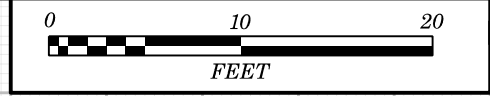

165 ROADWAY EMBANKMENT, SOFT TO MEDIUM STIFF, ORANGE, GRAY, TAN, COARSE TO FINE SANDY CLAY, WET, MODERATELY PLASTIC (A-6)

160 ALLUVIAL, SOFT, DARK GRAY, FINE TO COARSE SANDY SILT, SATURATED, TRACE (4.5%) ORGANICS, NON PLASTIC (A-4)

155 EXISTING PAVEMENT

150 4:1

145 S-099

145 L_36800_RT

145 368+00 -L-

145 91' RT

140 UNDIVIDED COASTAL PLAIN, SOFT TO MEDIUM STIFF, GRAY, ORANGE, MOTTLED, CLAY, WET, HIGHLY PLASTIC (A-7-6)

140 COASTAL PLAIN, MEDIUM DENSE, LIGHT GRAY, FINE TO COARSE SAND, SATURATED (A-2-4) (BLACK CREEK FORMATION)

135 BT

01/20

368+00
2 OF 2

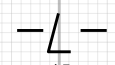

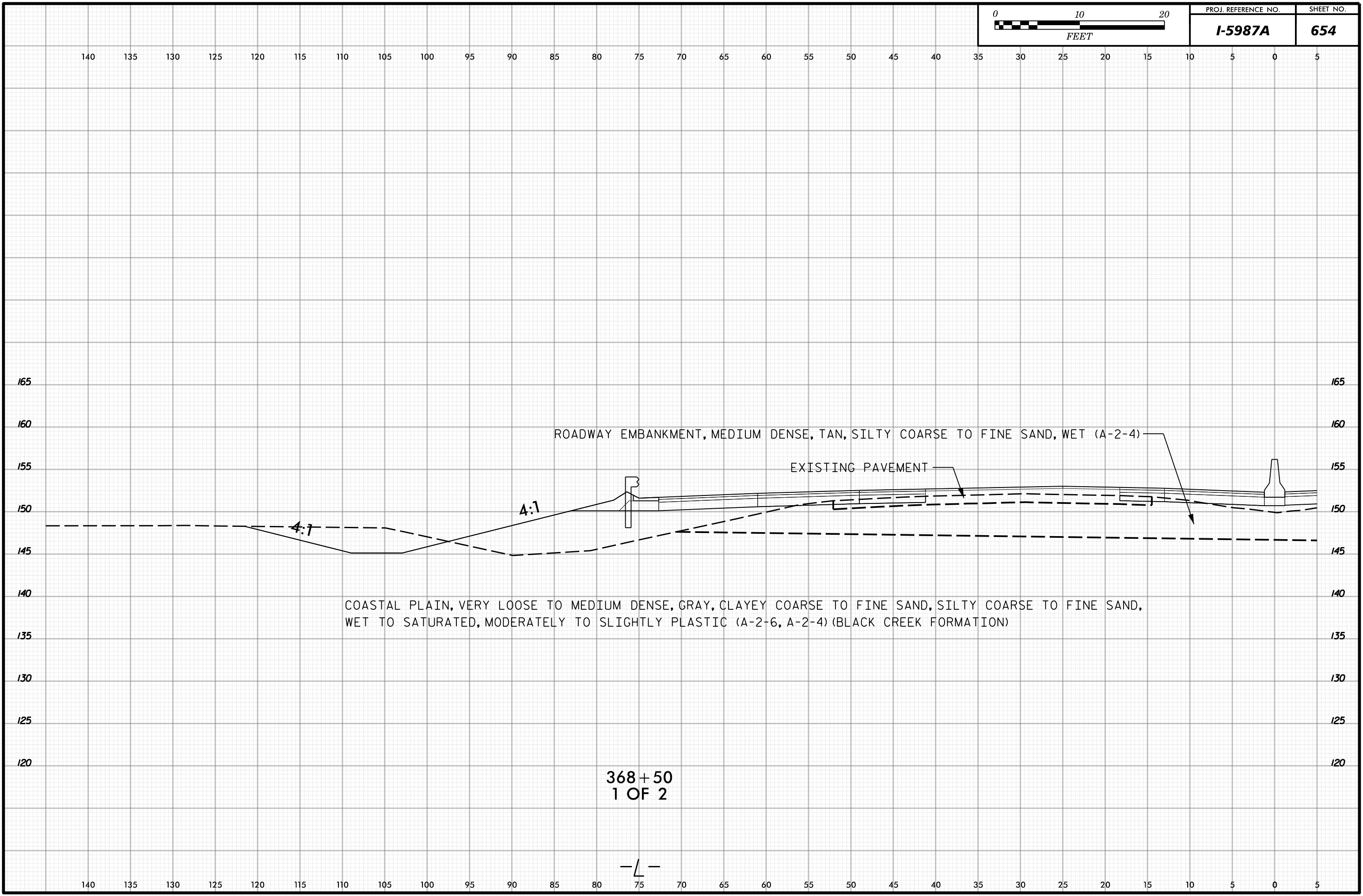

368+50
1 OF 2

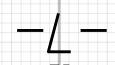



5 0 5 10 15 20 25 30 35 40 45 50 55 60 65 70 75 80 85 90 95 100 105 110 115 120 125 130 135 140 145

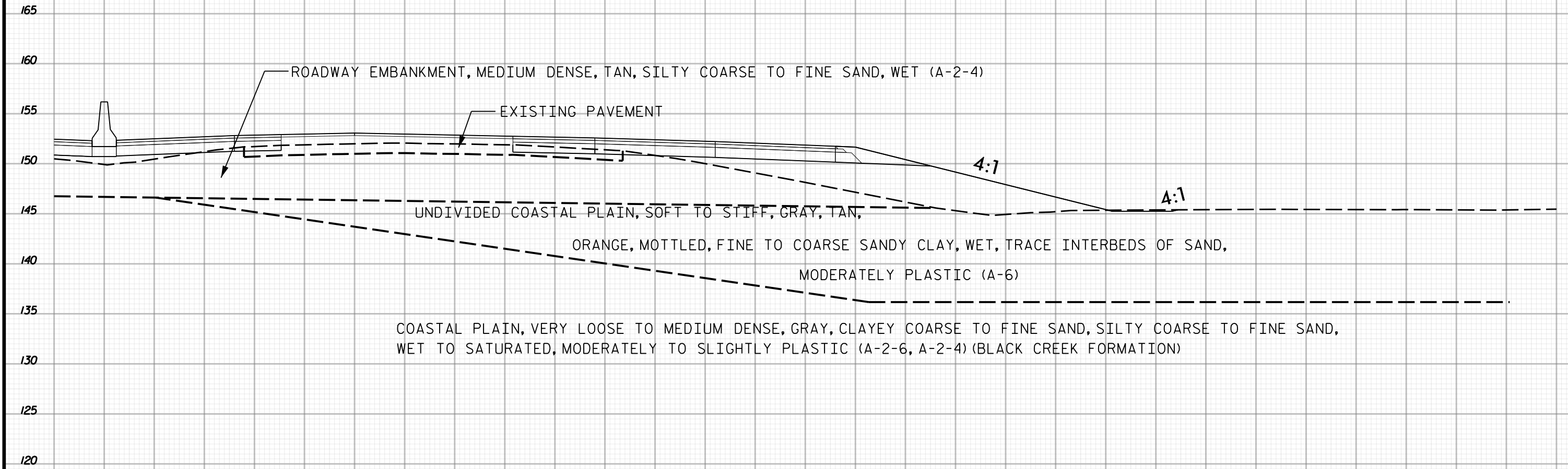

ROADWAY EMBANKMENT, MEDIUM DENSE, TAN, SILTY COARSE TO FINE SAND, WET (A-2-4)

EXISTING PAVEMENT

UNDIVIDED COASTAL PLAIN, SOFT TO STIFF, GRAY, TAN,
ORANGE, MOTTLED, FINE TO COARSE SANDY CLAY, WET, TRACE INTERBEDS OF SAND,
MODERATELY PLASTIC (A-6)

COASTAL PLAIN, VERY LOOSE TO MEDIUM DENSE, GRAY, CLAYEY COARSE TO FINE SAND, SILTY COARSE TO FINE SAND,
WET TO SATURATED, MODERATELY TO SLIGHTLY PLASTIC (A-2-6, A-2-4) (BLACK CREEK FORMATION)

368+50
2 OF 2

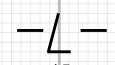

5 0 5 10 15 20 25 30 35 40 45 50 55 60 65 70 75 80 85 90 95 100 105 110 115 120 125 130 135 140 145

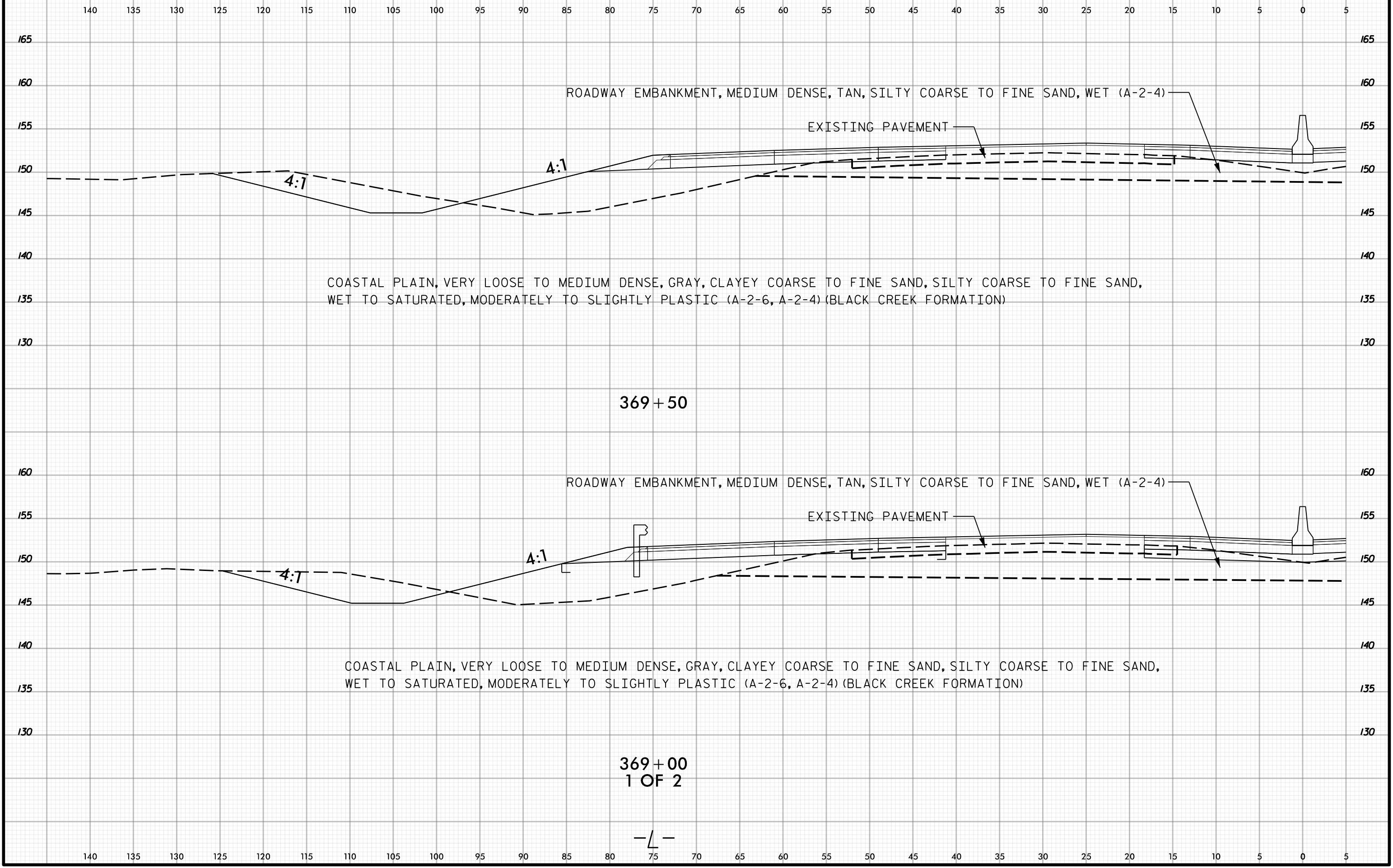

369+50

369+00
1 OF 2

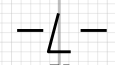

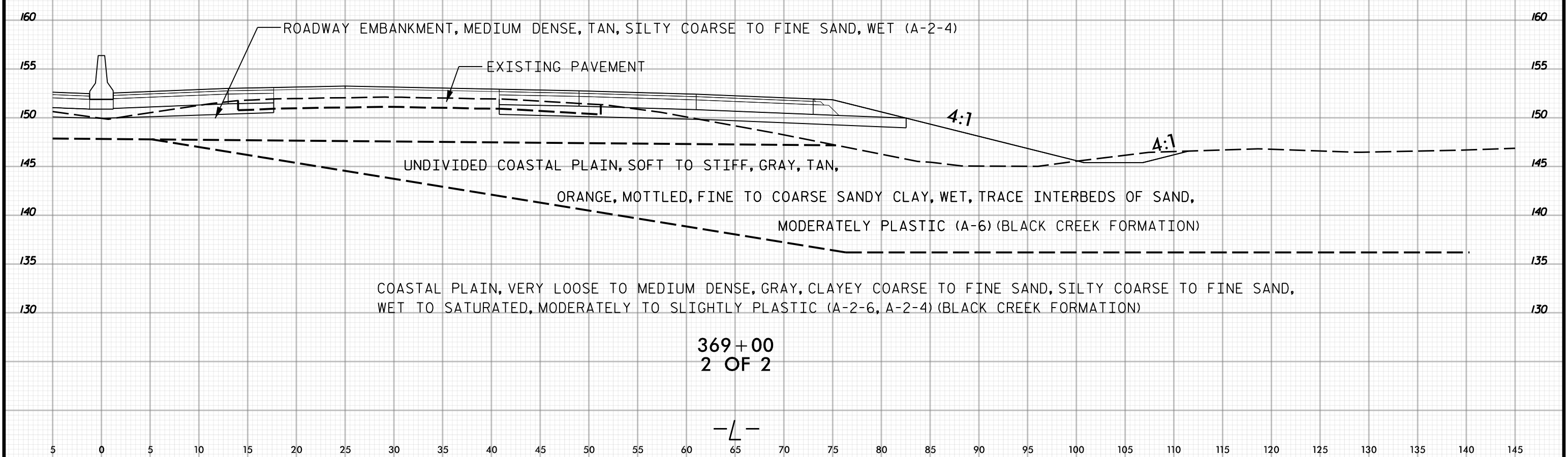
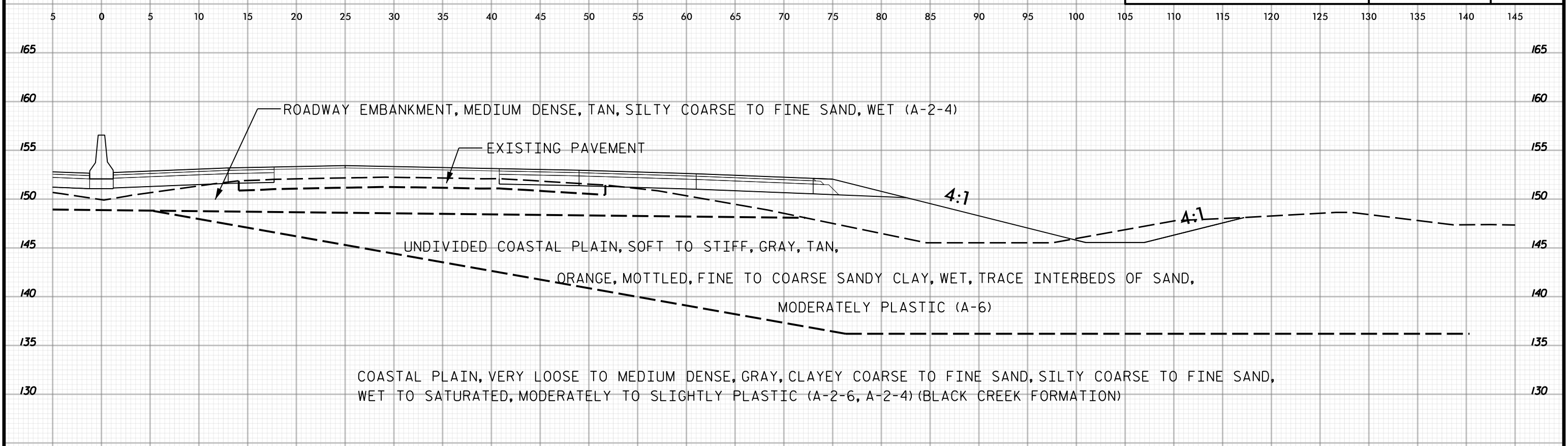
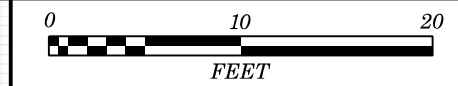

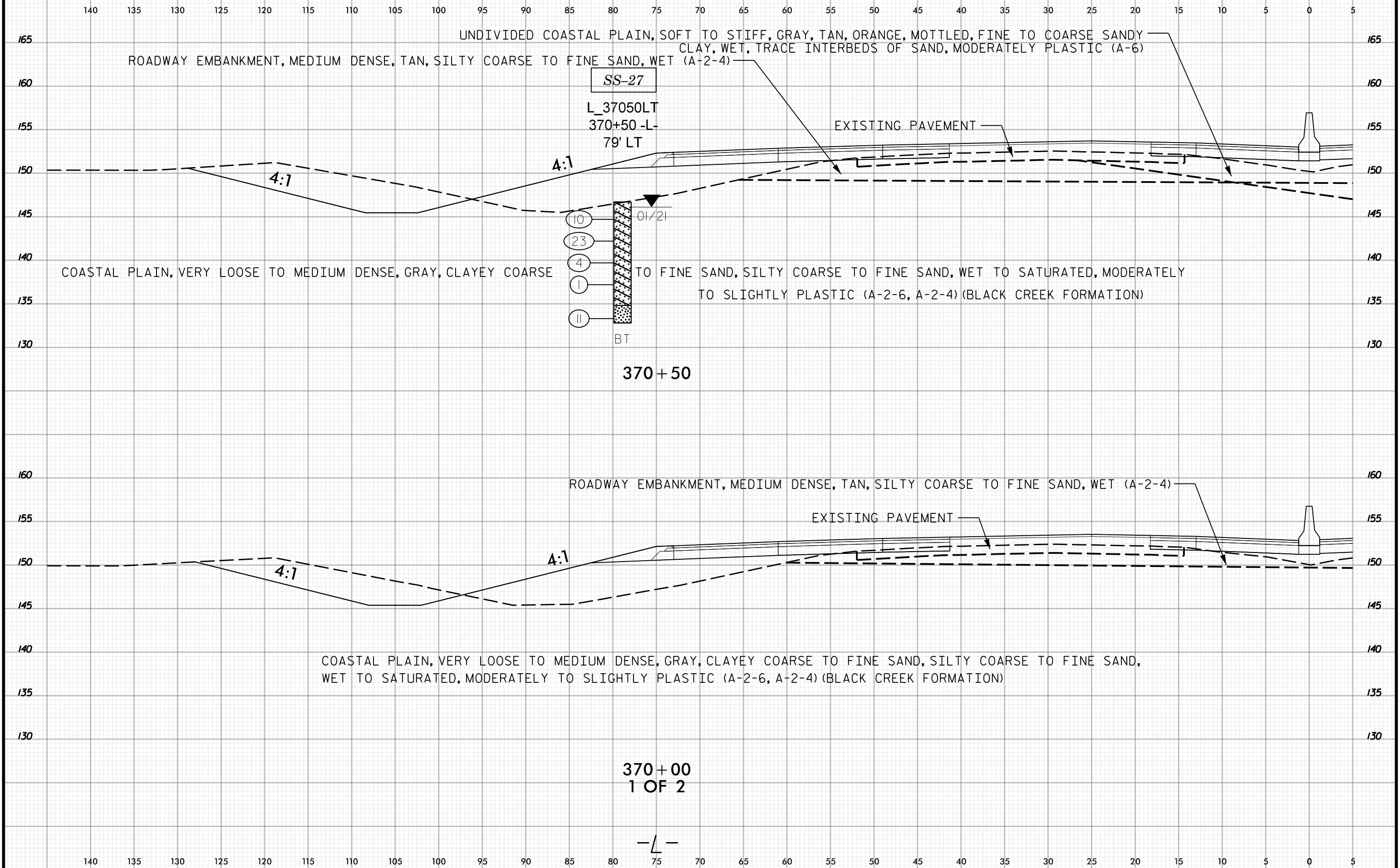

370+00
1 OF 2

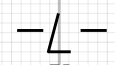

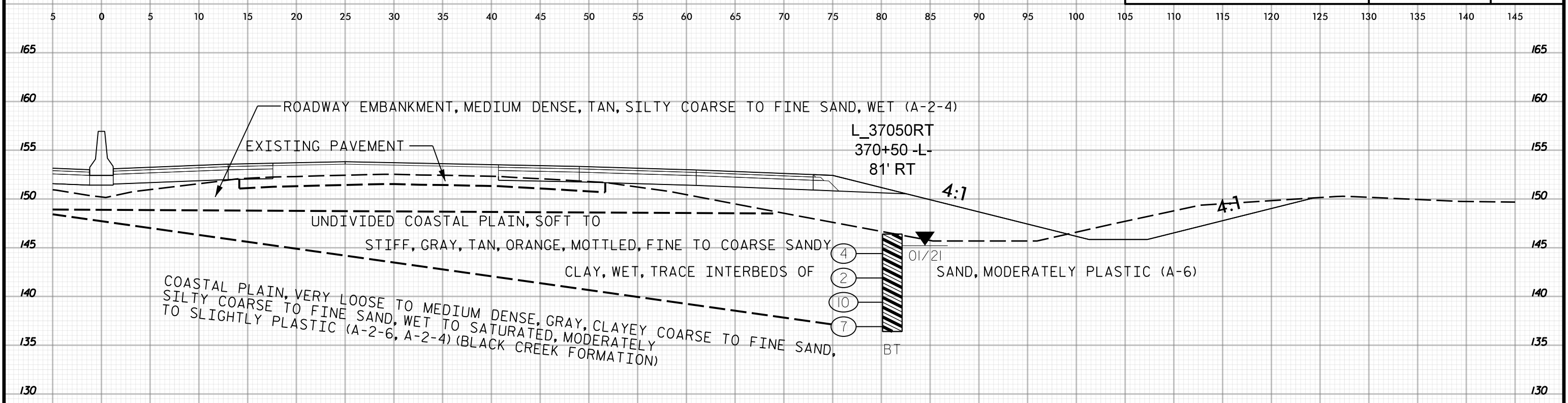

370+50

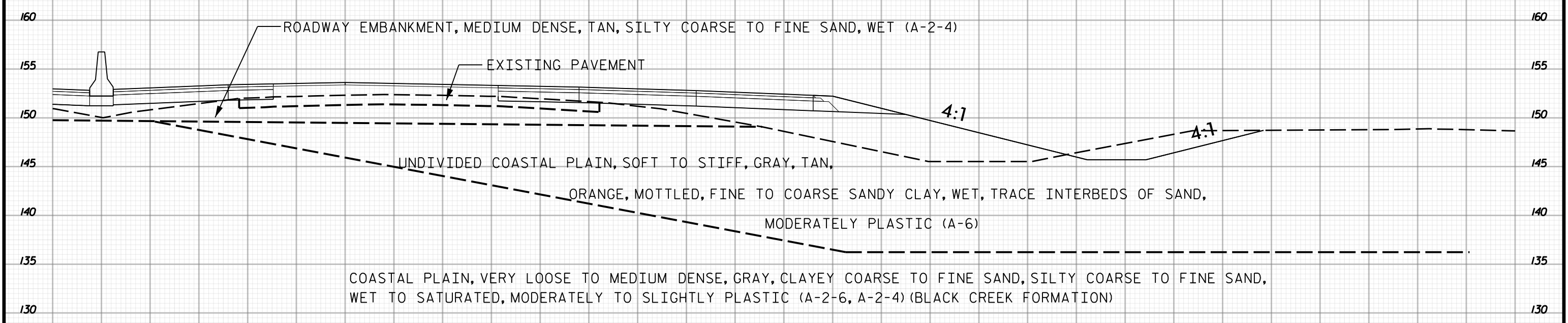

370+00
2 OF 2

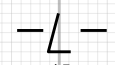

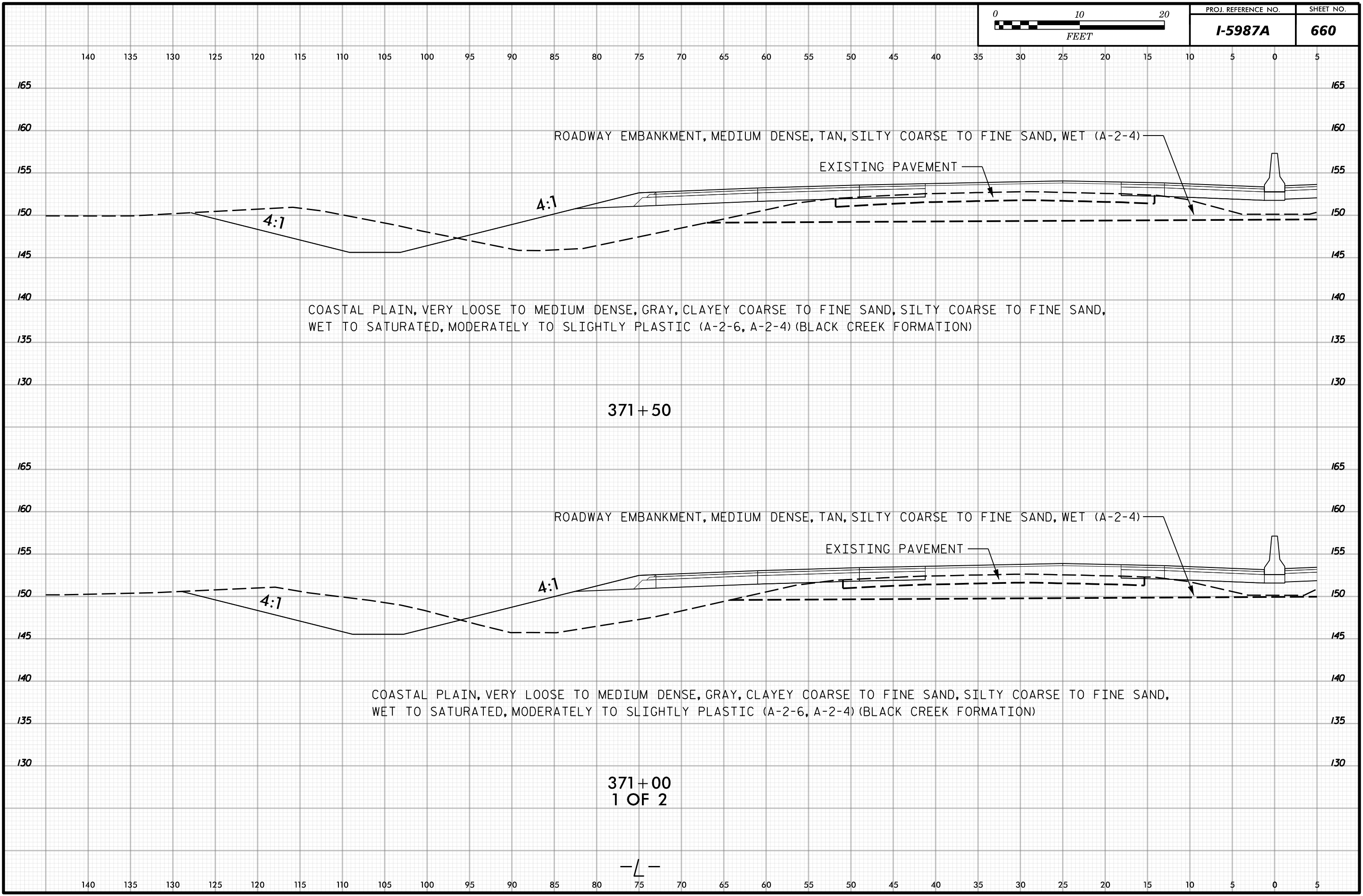

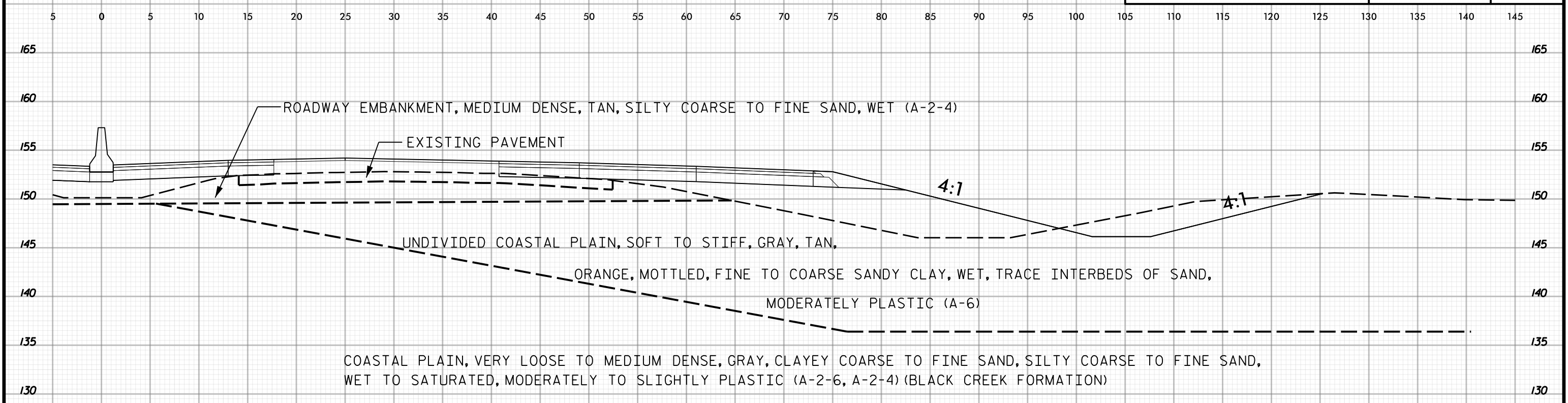

371+50

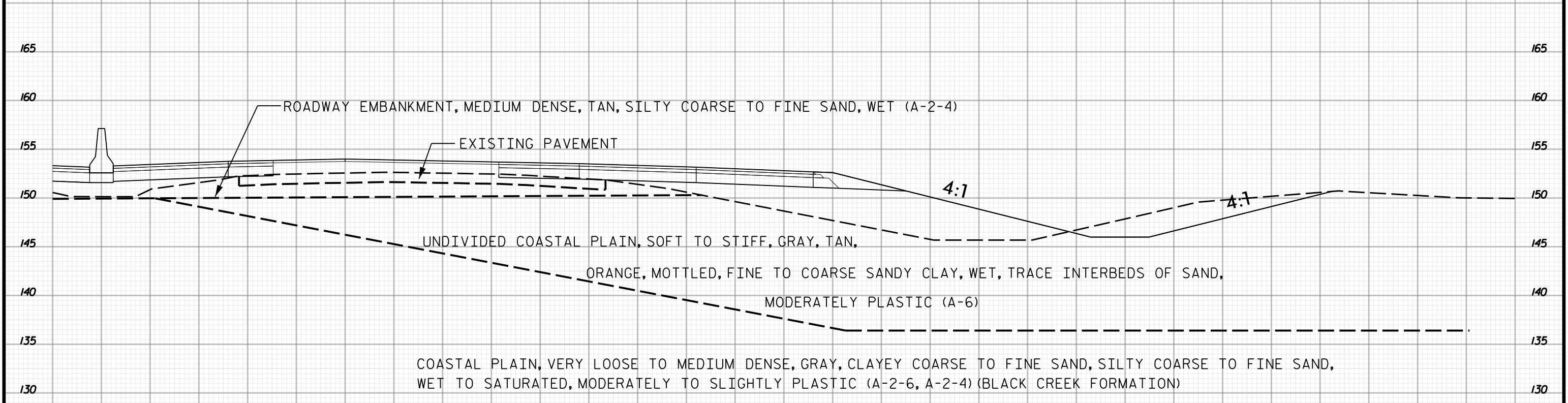

371+00
2 OF 2

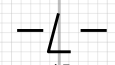

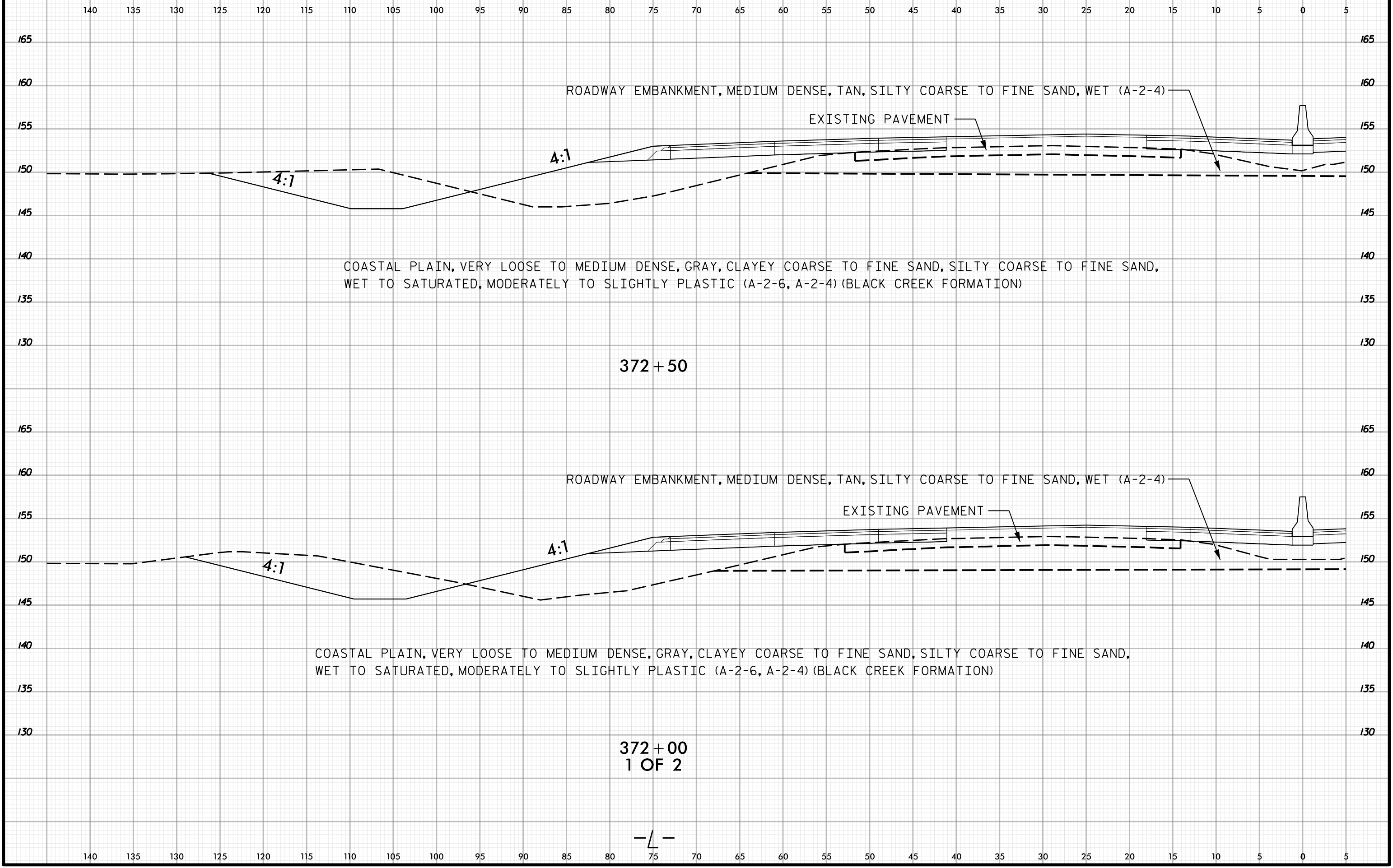

372+50

372+00
1 OF 2

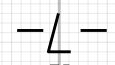

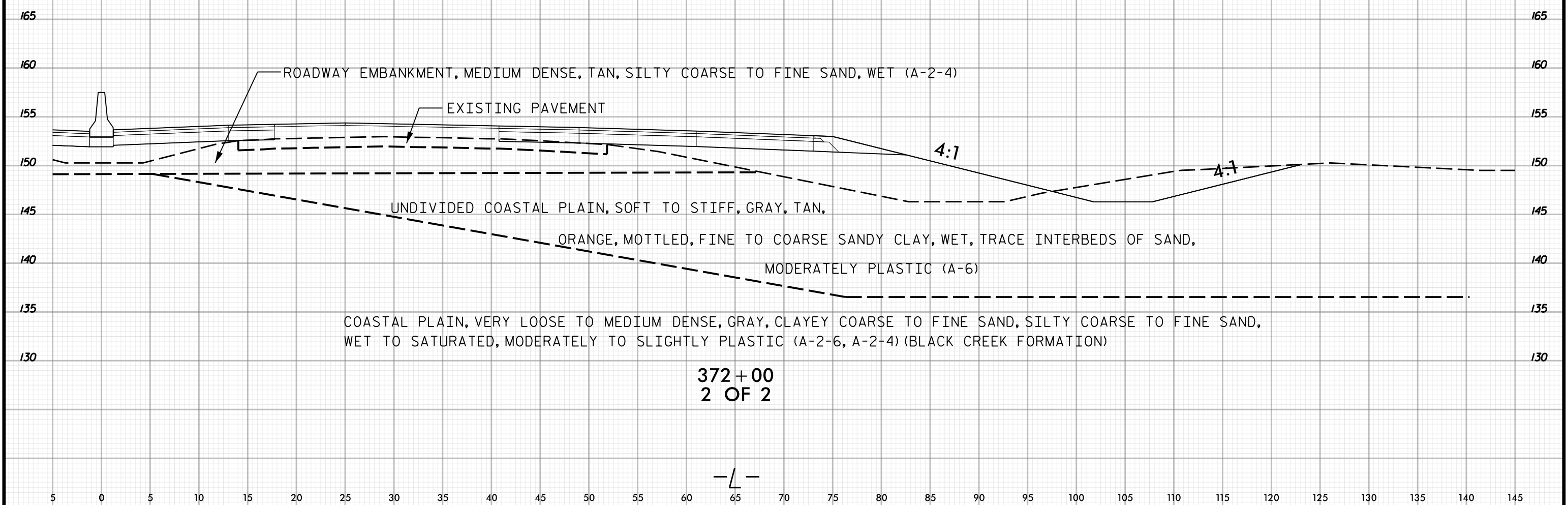
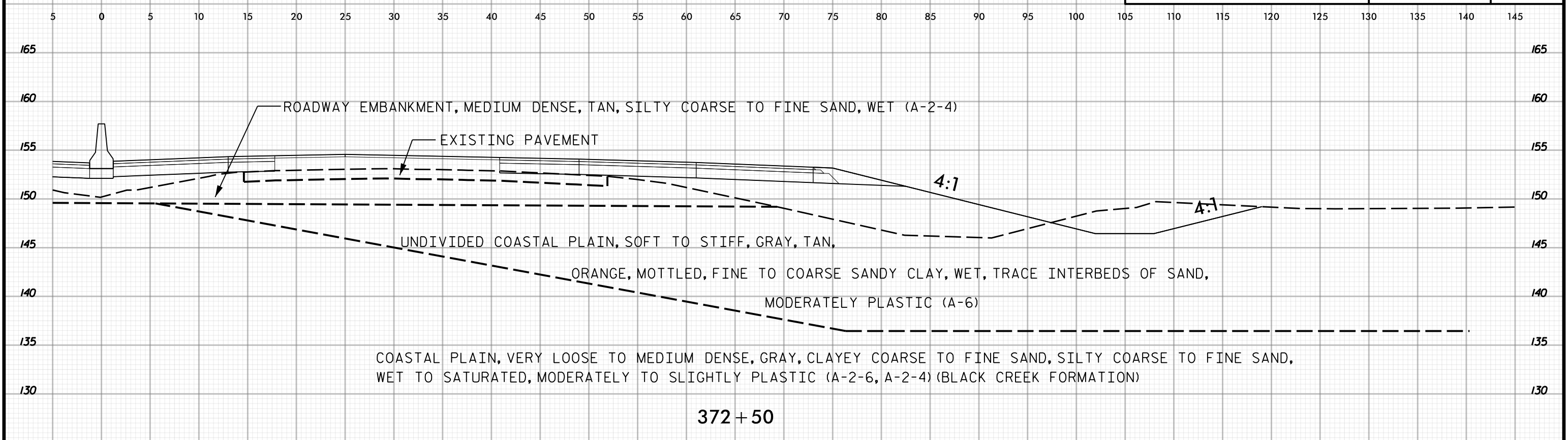
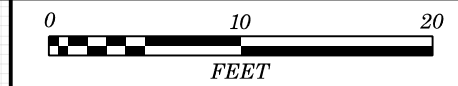



140 135 130 125 120 115 110 105 100 95 90 85 80 75 70 65 60 55 50 45 40 35 30 25 20 15 10 5 0 5

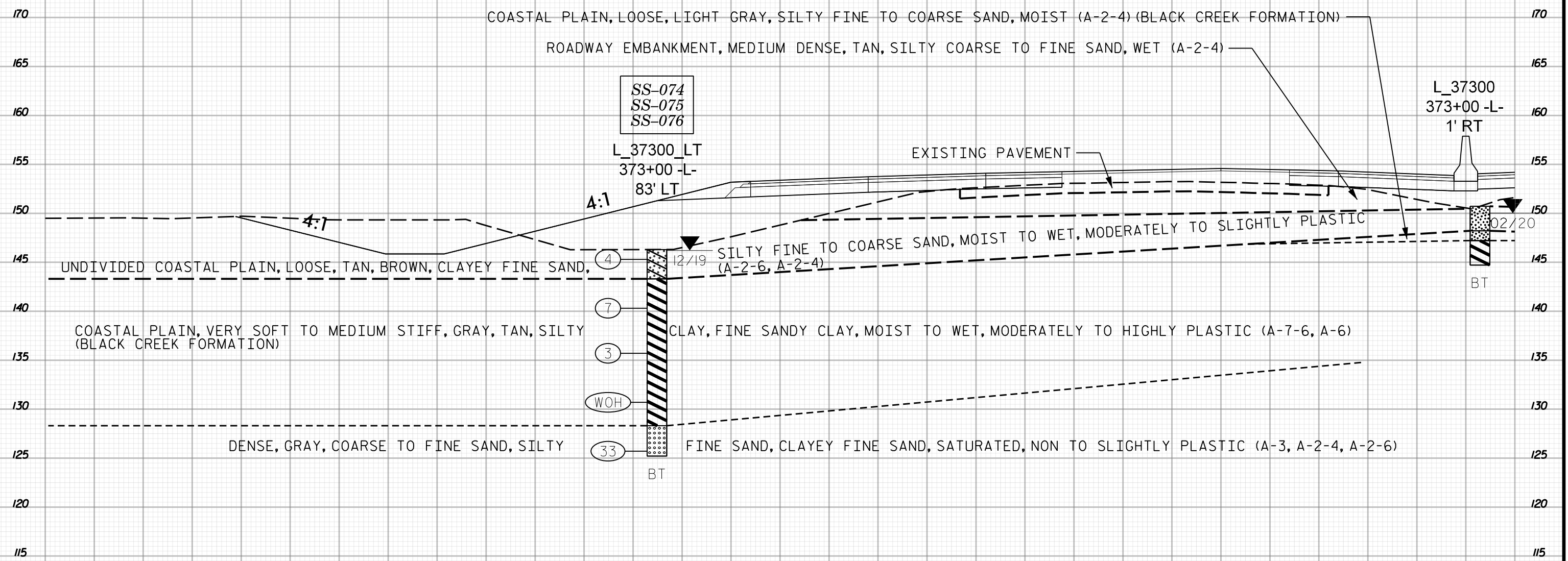

373+00
1 OF 2

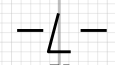

140 135 130 125 120 115 110 105 100 95 90 85 80 75 70 65 60 55 50 45 40 35 30 25 20 15 10 5 0 5

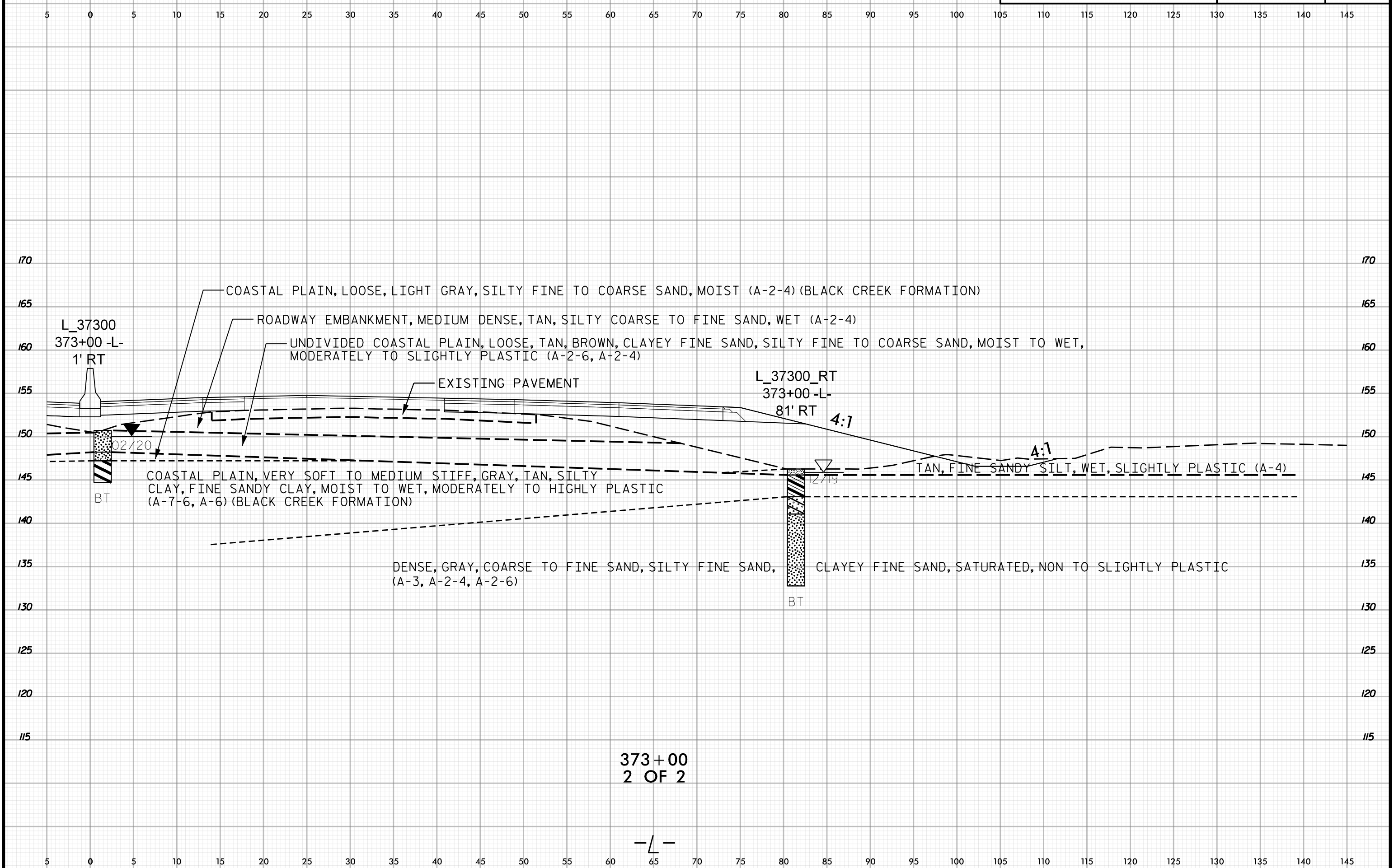
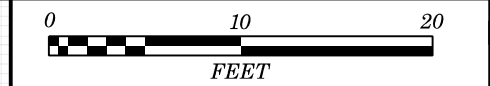



PROJ. REFERENCE NO.	SHEET NO.
I-5987A	666

140 135 130 125 120 115 110 105 100 95 90 85 80 75 70 65 60 55 50 45 40 35 30 25 20 15 10 5 0 5

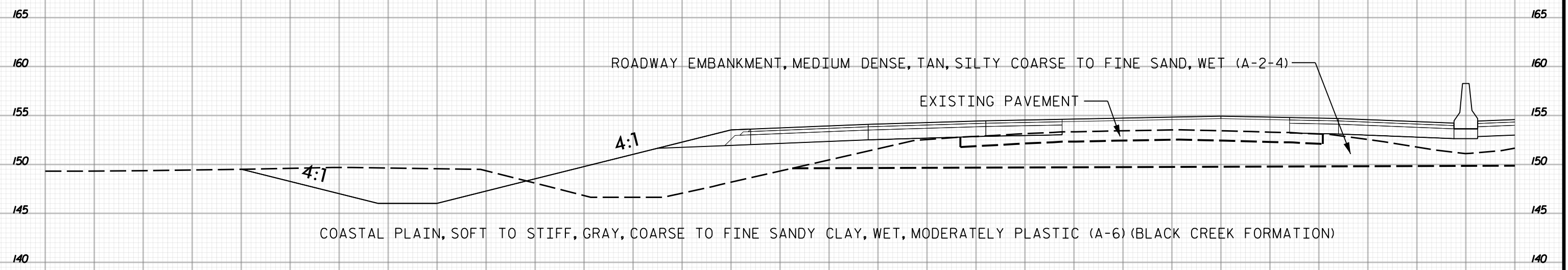

374+00

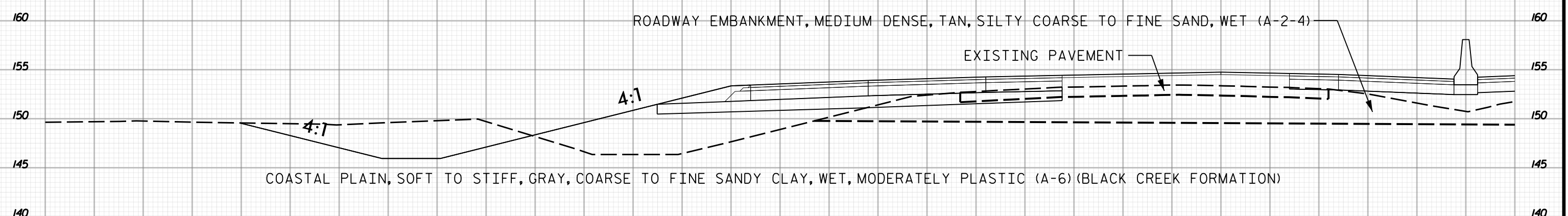

373+50
1 OF 2

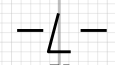

140 135 130 125 120 115 110 105 100 95 90 85 80 75 70 65 60 55 50 45 40 35 30 25 20 15 10 5 0 5

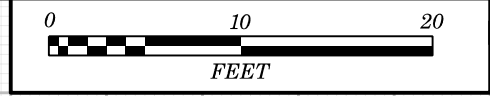

PROJ. REFERENCE NO.	SHEET NO.
I-5987A	667

5 0 5 10 15 20 25 30 35 40 45 50 55 60 65 70 75 80 85 90 95 100 105 110 115 120 125 130 135 140 145

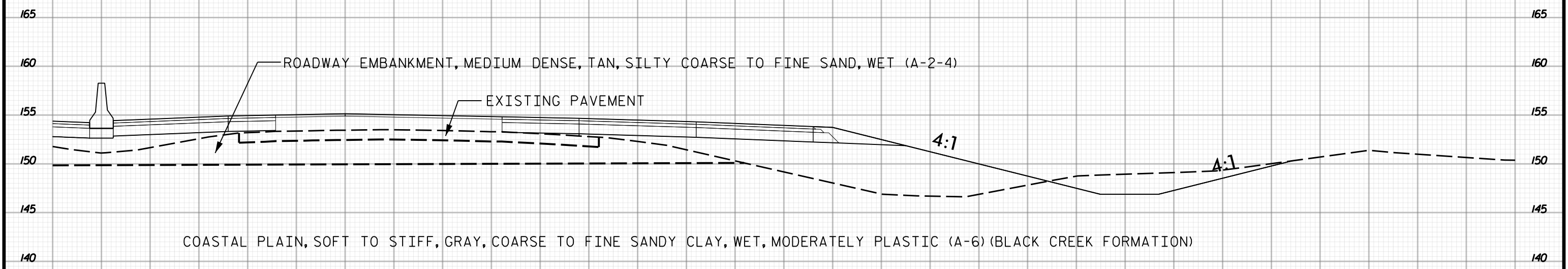

374+00

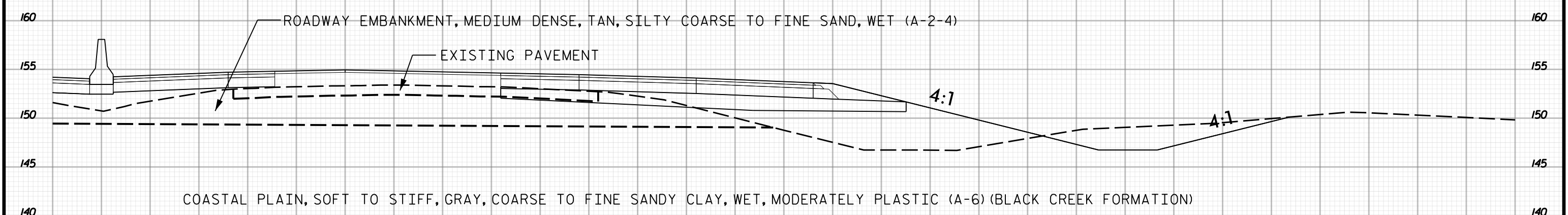

373+50
2 OF 2

-L-

5 0 5 10 15 20 25 30 35 40 45 50 55 60 65 70 75 80 85 90 95 100 105 110 115 120 125 130 135 140 145

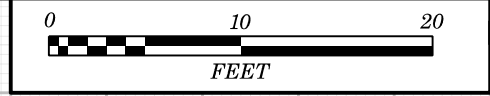

PROJ. REFERENCE NO.	SHEET NO.
I-5987A	668

140 135 130 125 120 115 110 105 100 95 90 85 80 75 70 65 60 55 50 45 40 35 30 25 20 15 10 5 0 5

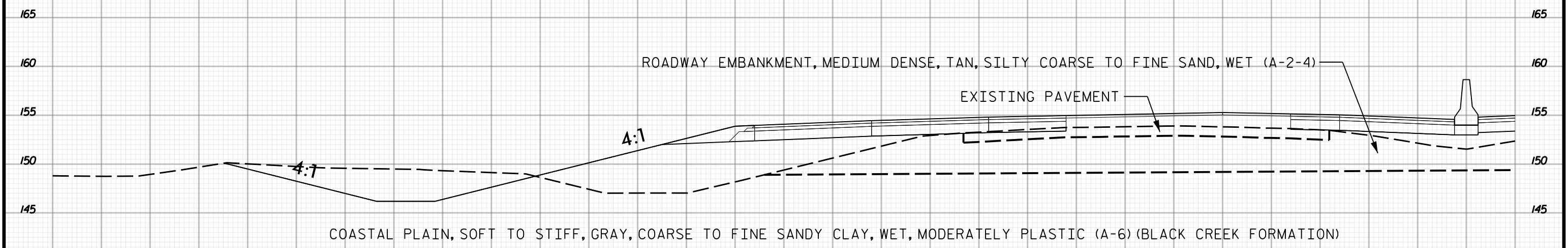

375+00

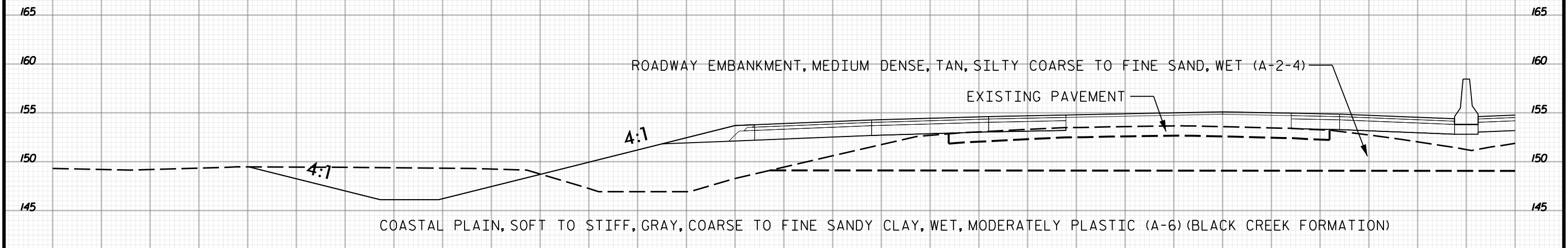

374+50
1 OF 2

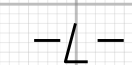

140 135 130 125 120 115 110 105 100 95 90 85 80 75 70 65 60 55 50 45 40 35 30 25 20 15 10 5 0 5



PROJ. REFERENCE NO.	SHEET NO.
I-5987A	669

5 0 5 10 15 20 25 30 35 40 45 50 55 60 65 70 75 80 85 90 95 100 105 110 115 120 125 130 135 140 145

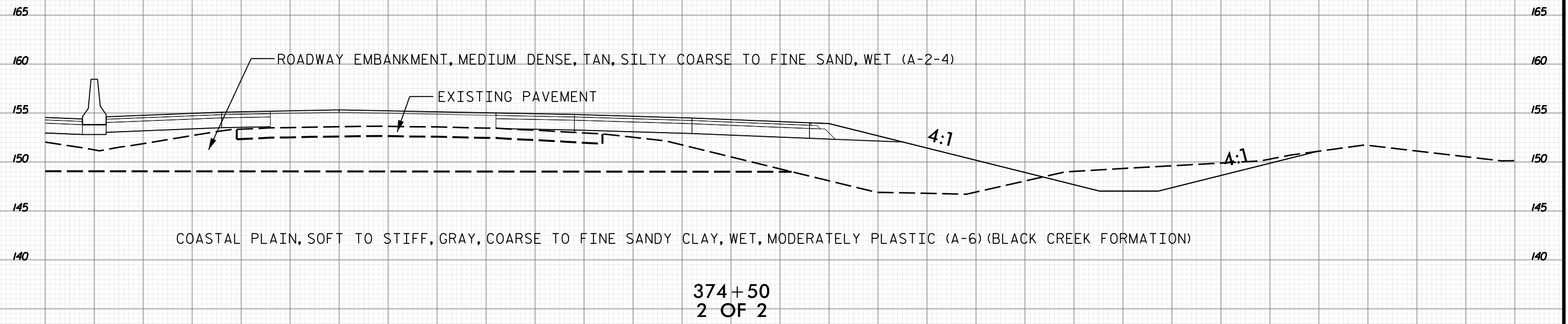
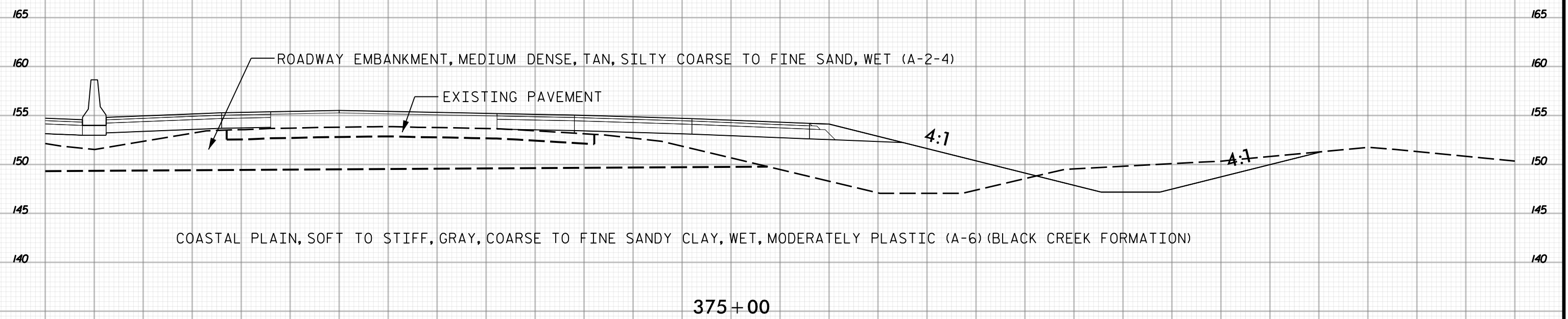

5 0 5 10 15 20 25 30 35 40 45 50 55 60 65 70 75 80 85 90 95 100 105 110 115 120 125 130 135 140 145

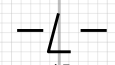



140 135 130 125 120 115 110 105 100 95 90 85 80 75 70 65 60 55 50 45 40 35 30 25 20 15 10 5 0 5

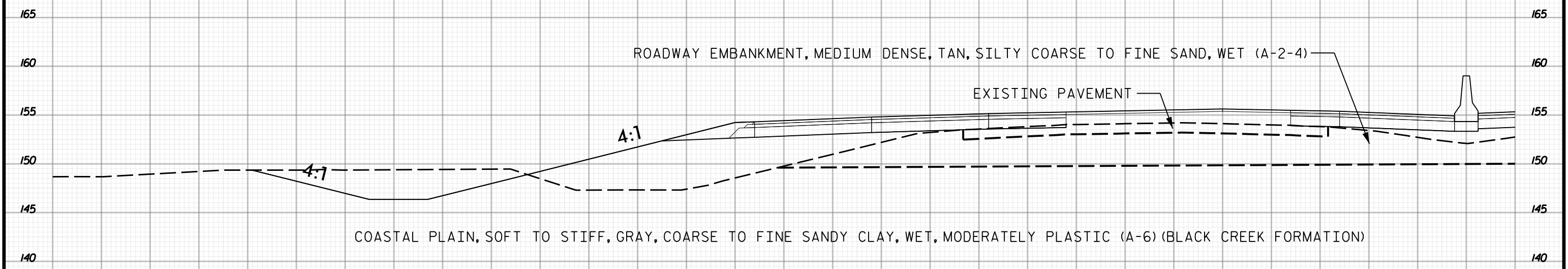

376+00

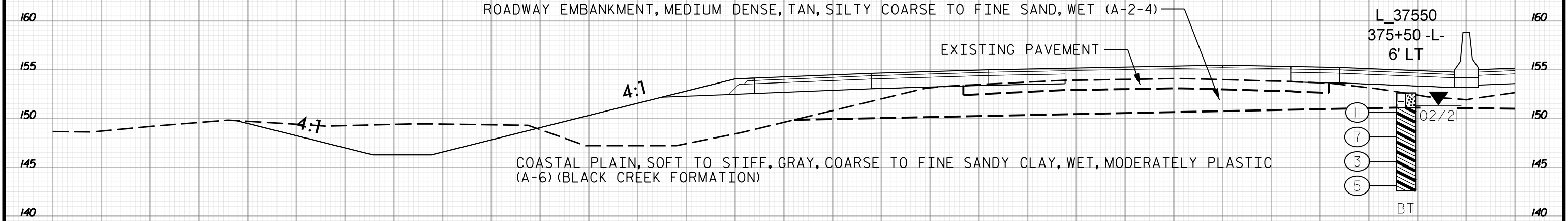

375+50
1 OF 2

140 135 130 125 120 115 110 105 100 95 90 85 80 75 70 65 60 55 50 45 40 35 30 25 20 15 10 5 0 5

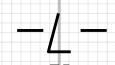



PROJ. REFERENCE NO.	SHEET NO.
I-5987A	671

5 0 5 10 15 20 25 30 35 40 45 50 55 60 65 70 75 80 85 90 95 100 105 110 115 120 125 130 135 140 145

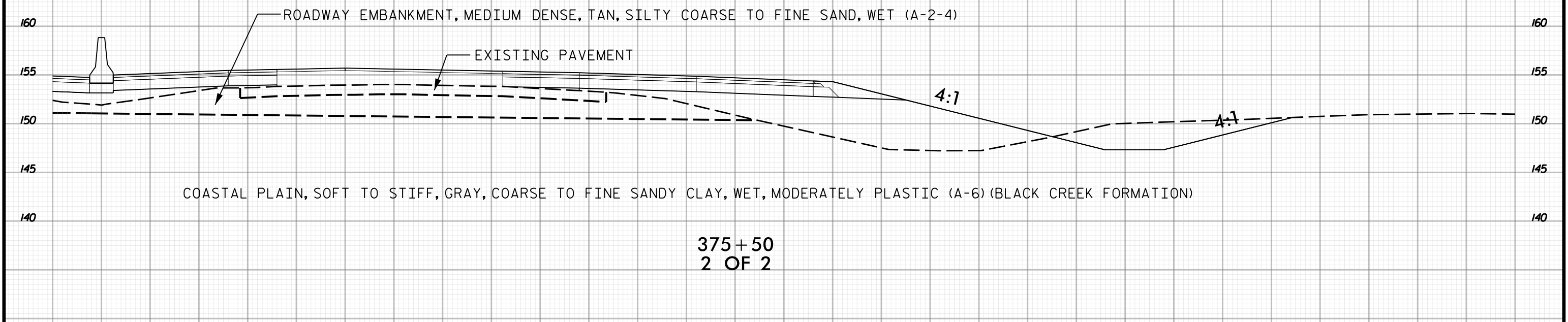
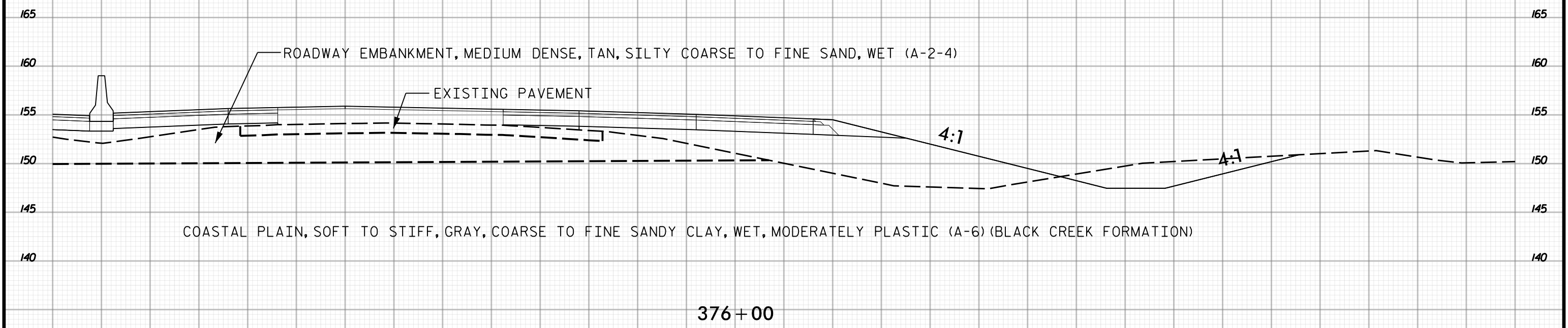

5 0 5 10 15 20 25 30 35 40 45 50 55 60 65 70 75 80 85 90 95 100 105 110 115 120 125 130 135 140 145

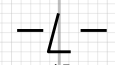



140 135 130 125 120 115 110 105 100 95 90 85 80 75 70 65 60 55 50 45 40 35 30 25 20 15 10 5 0 5

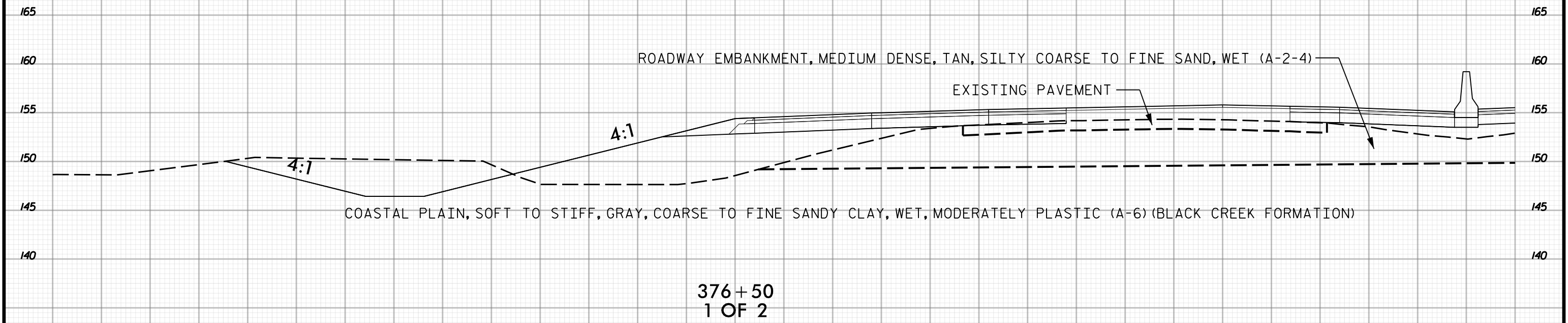
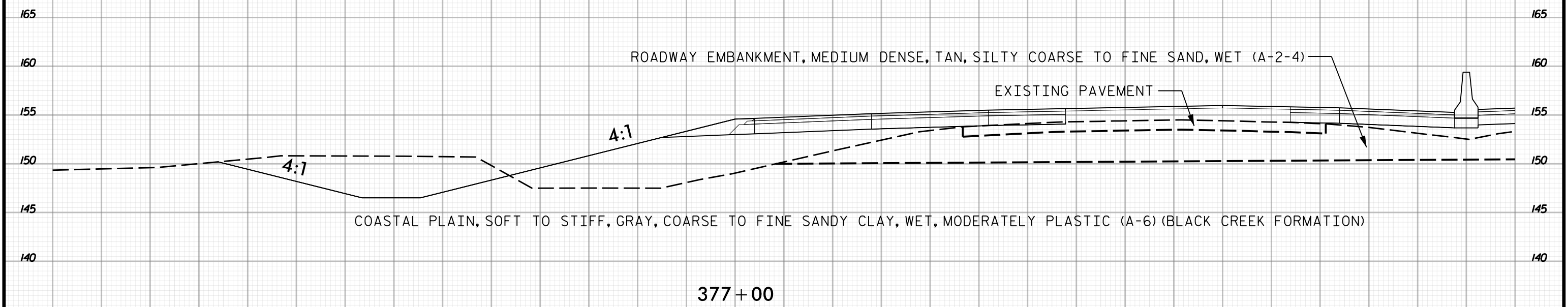

140 135 130 125 120 115 110 105 100 95 90 85 80 75 70 65 60 55 50 45 40 35 30 25 20 15 10 5 0 5

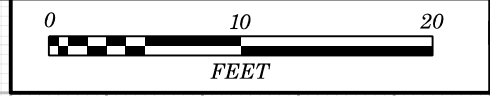

5 0 5 10 15 20 25 30 35 40 45 50 55 60 65 70 75 80 85 90 95 100 105 110 115 120 125 130 135 140 145

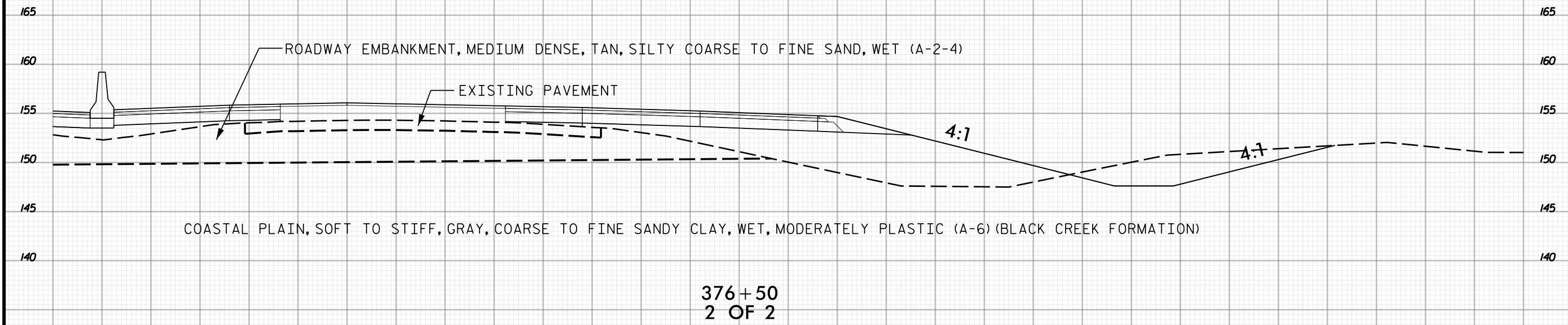
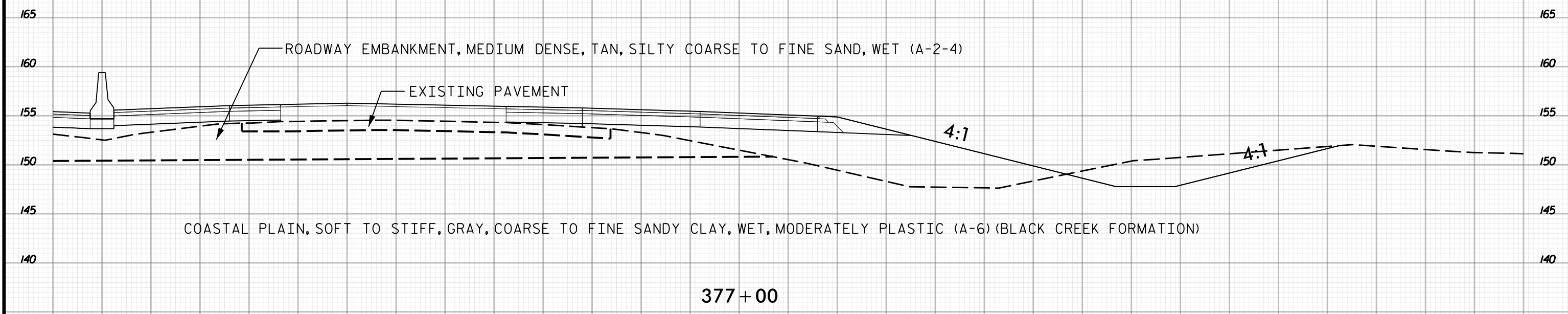

5 0 5 10 15 20 25 30 35 40 45 50 55 60 65 70 75 80 85 90 95 100 105 110 115 120 125 130 135 140 145



140 135 130 125 120 115 110 105 100 95 90 85 80 75 70 65 60 55 50 45 40 35 30 25 20 15 10 5 0 5

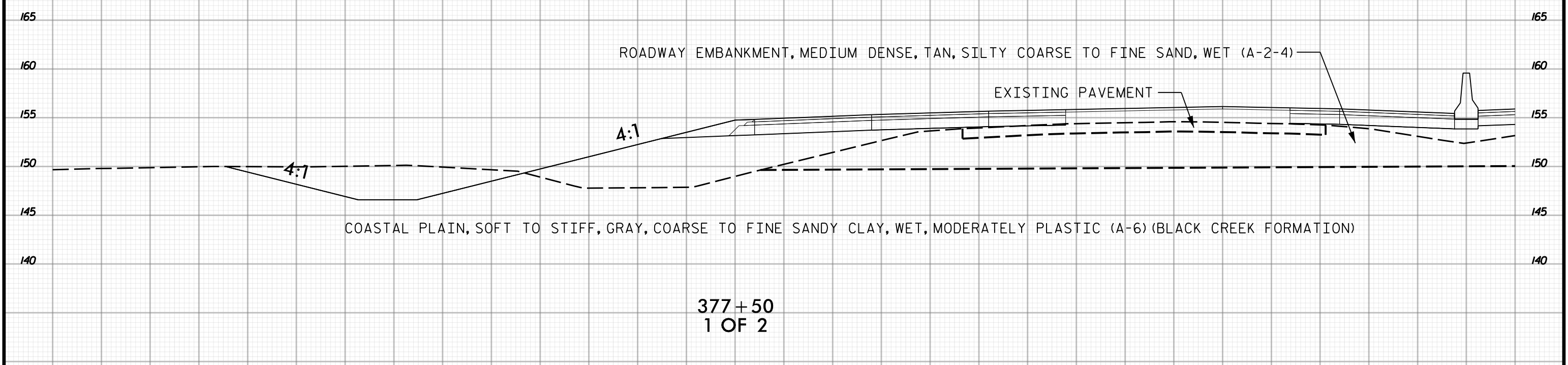
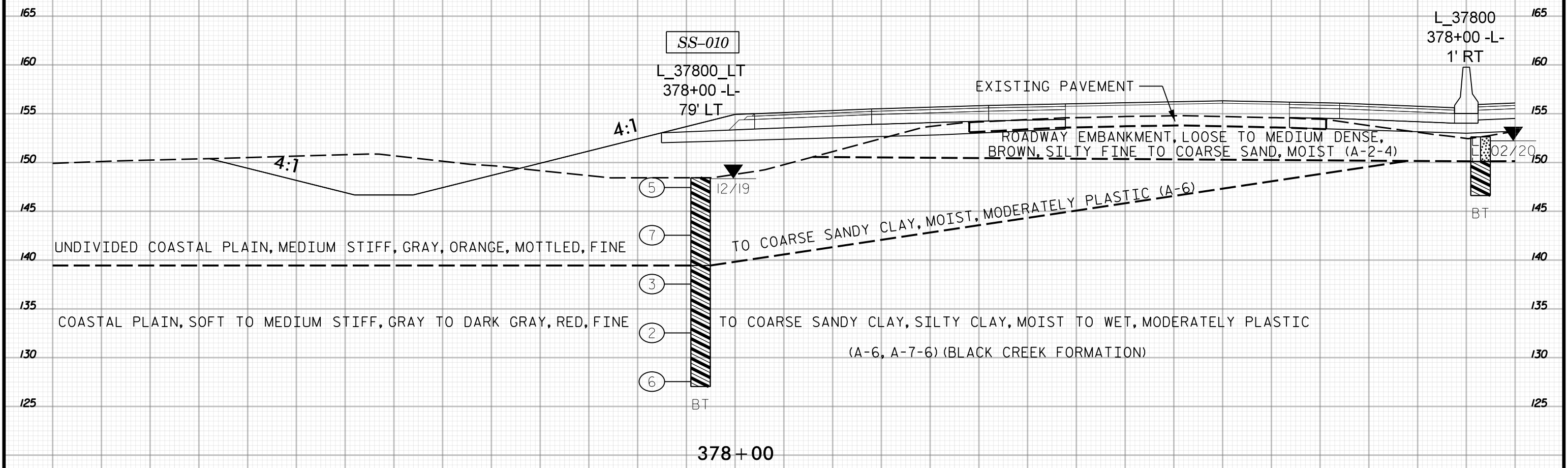

140 135 130 125 120 115 110 105 100 95 90 85 80 75 70 65 60 55 50 45 40 35 30 25 20 15 10 5 0 5

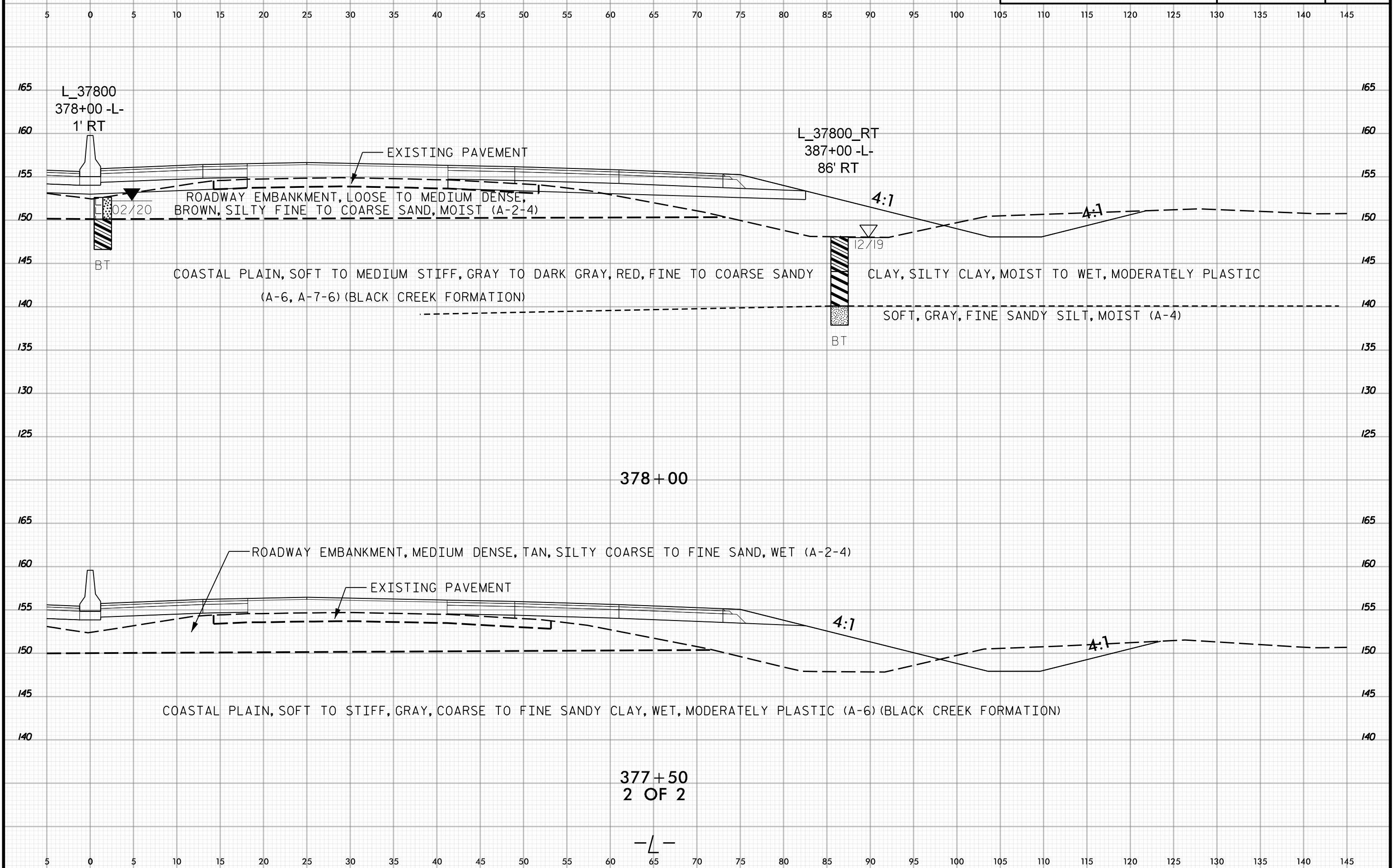

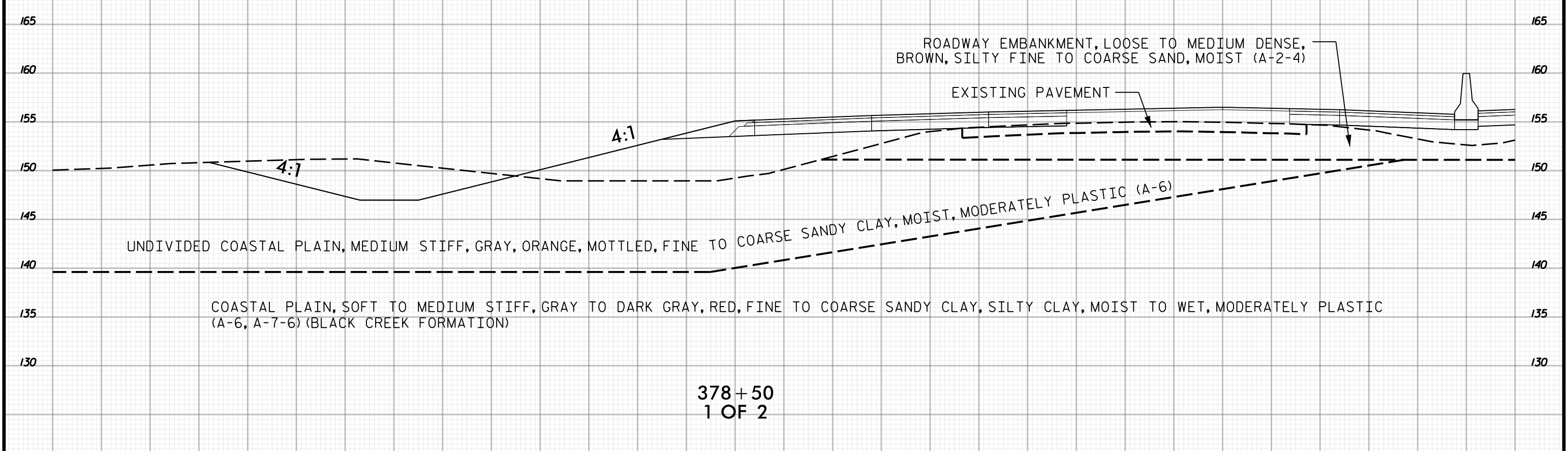
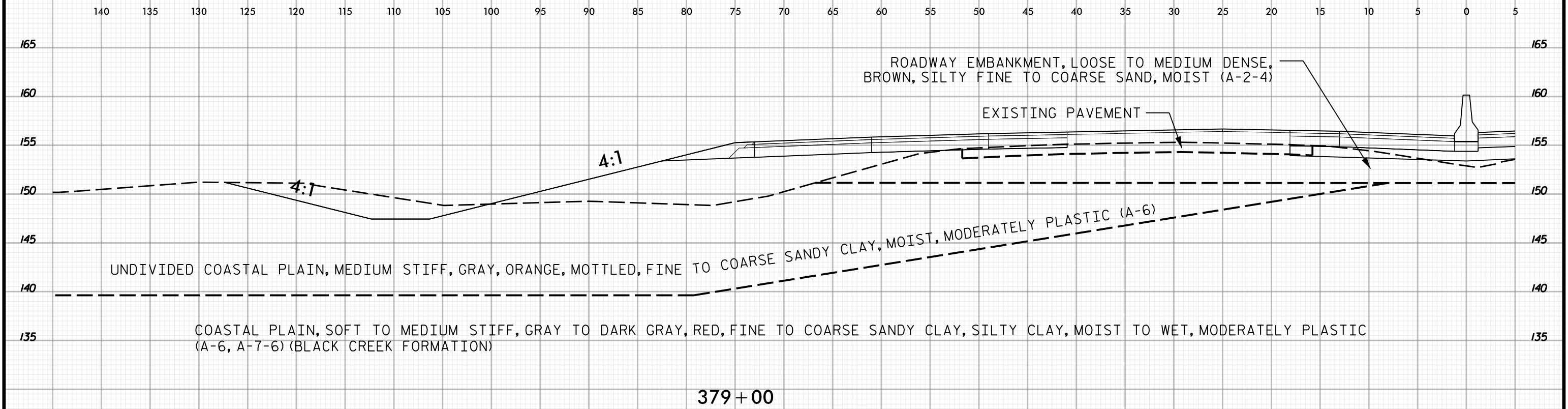

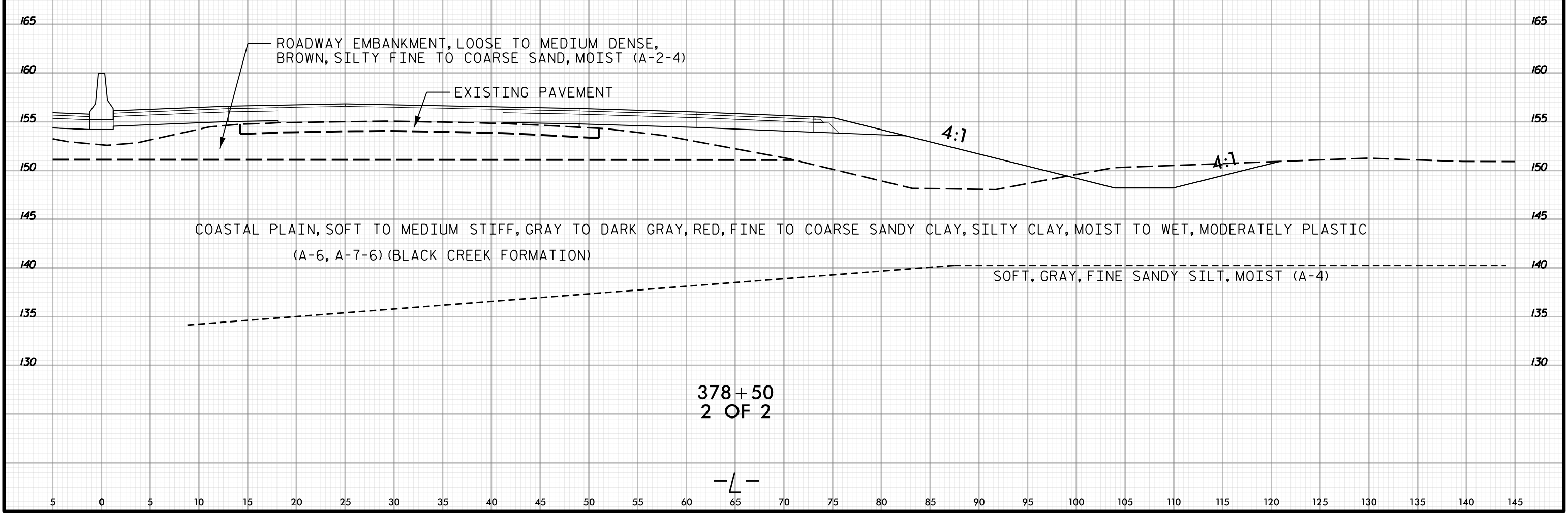
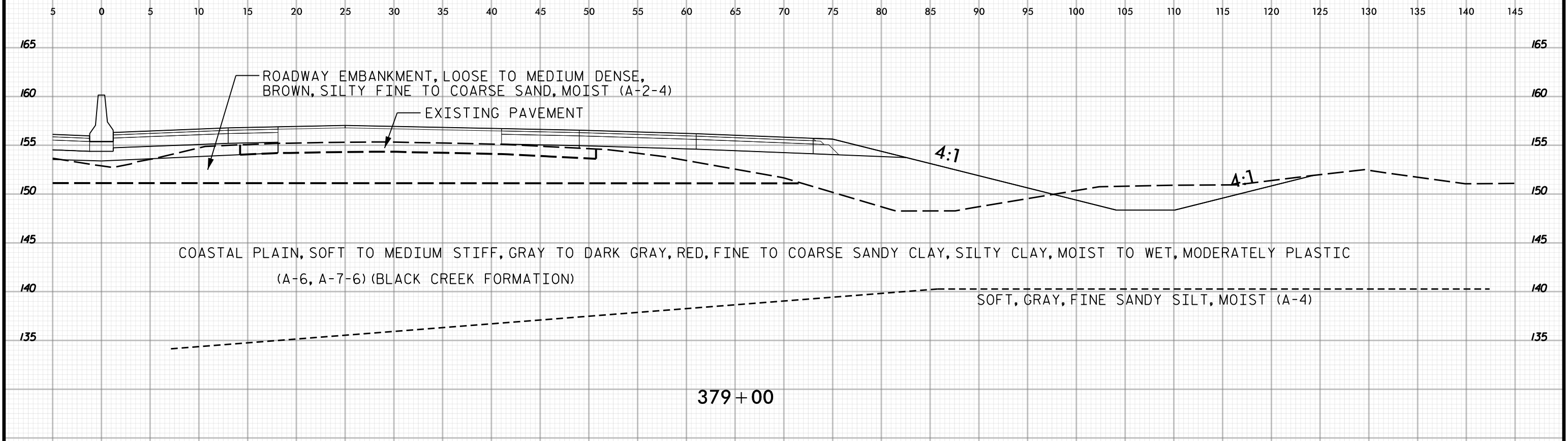

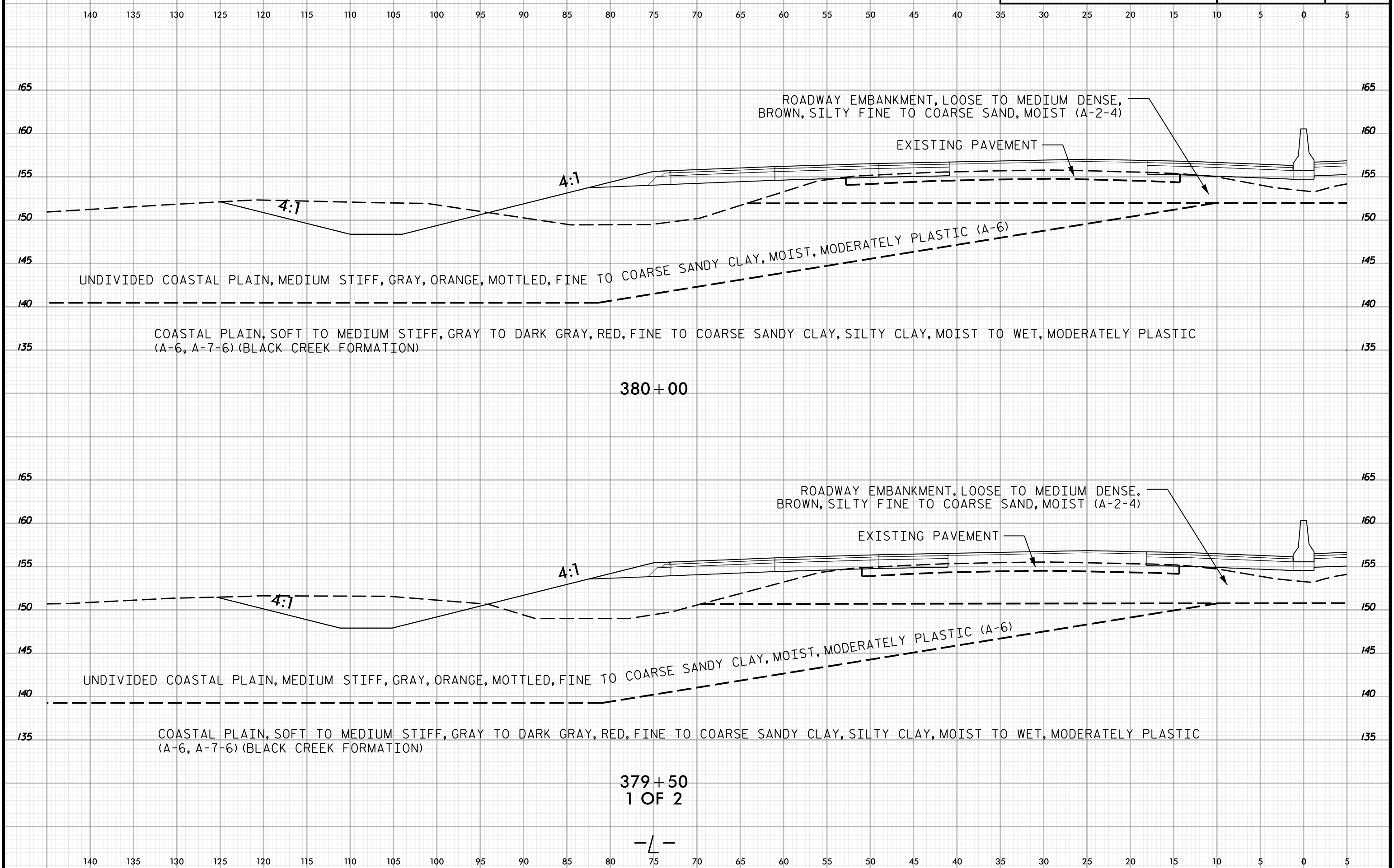

380+00

379+50
1 OF 2

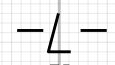

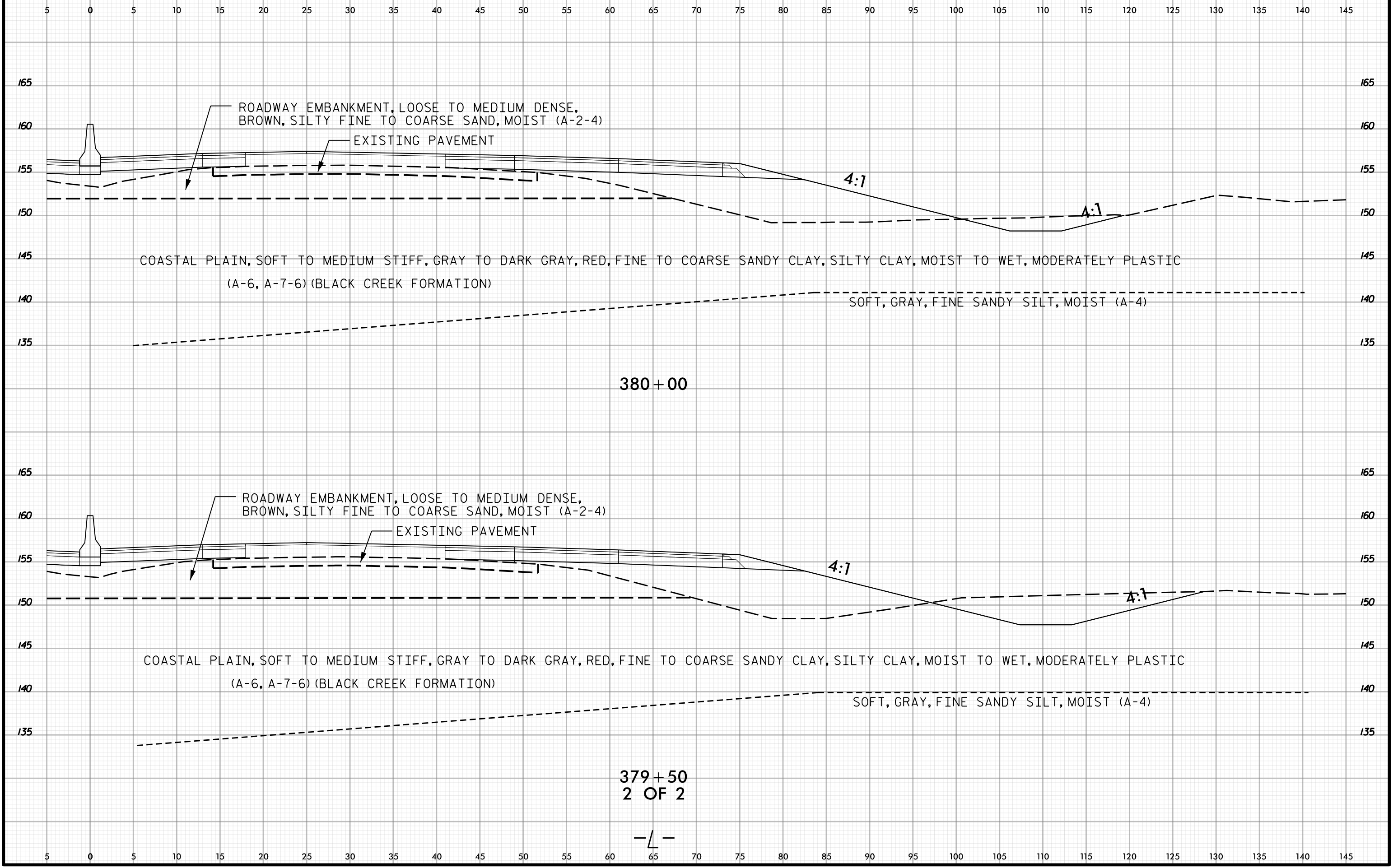
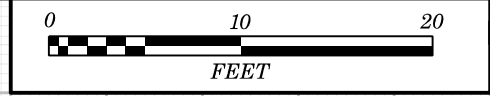

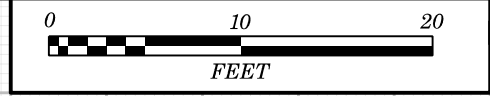

PROJ. REFERENCE NO.	SHEET NO.
I-5987A	680

140 135 130 125 120 115 110 105 100 95 90 85 80 75 70 65 60 55 50 45 40 35 30 25 20 15 10 5 0 5

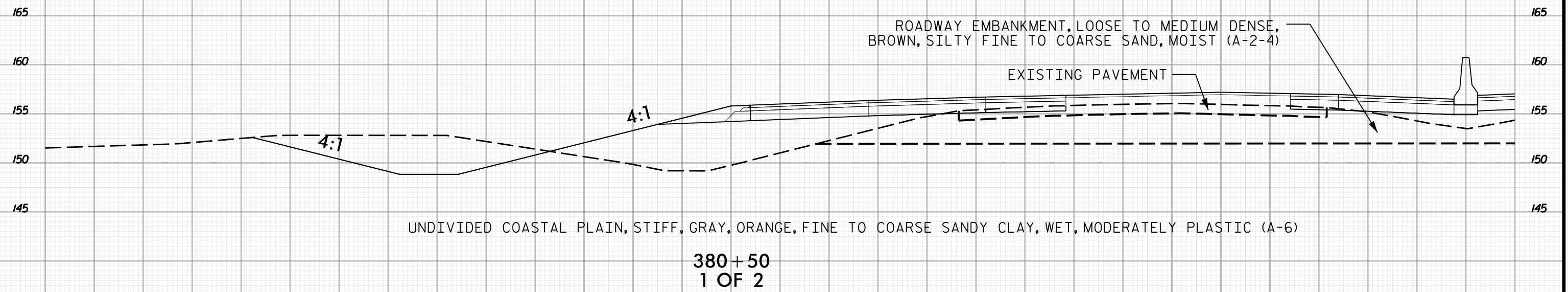
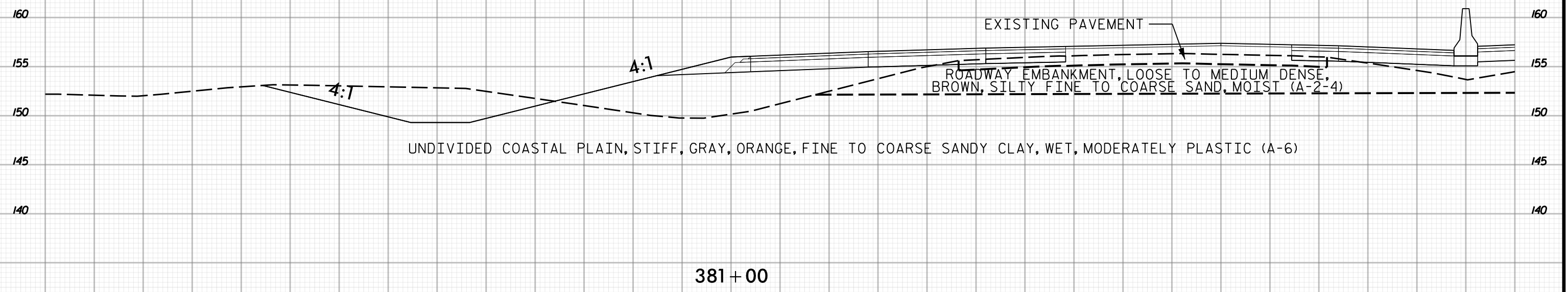

140 135 130 125 120 115 110 105 100 95 90 85 80 75 70 65 60 55 50 45 40 35 30 25 20 15 10 5 0 5

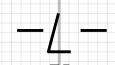

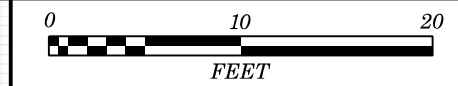

5 0 5 10 15 20 25 30 35 40 45 50 55 60 65 70 75 80 85 90 95 100 105 110 115 120 125 130 135 140 145

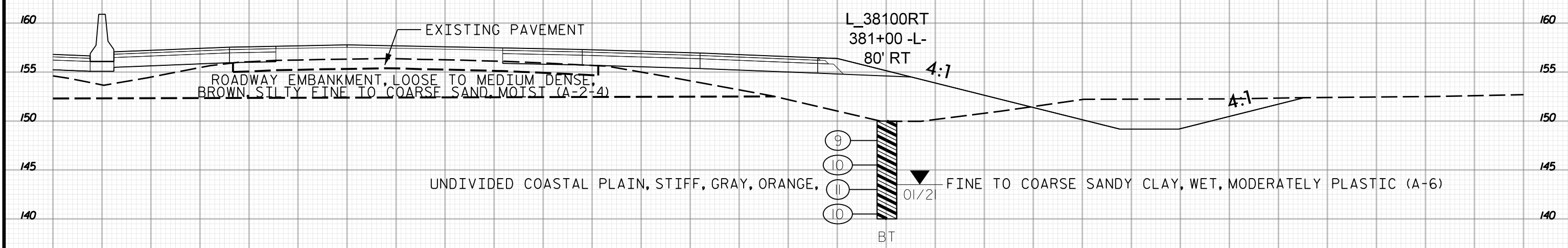

381 + 00

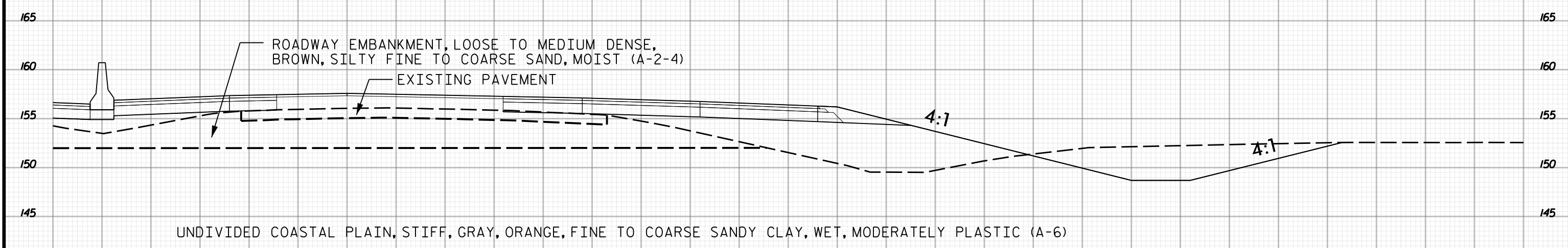

380 + 50
2 OF 2

-L-

5 0 5 10 15 20 25 30 35 40 45 50 55 60 65 70 75 80 85 90 95 100 105 110 115 120 125 130 135 140 145

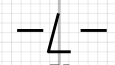
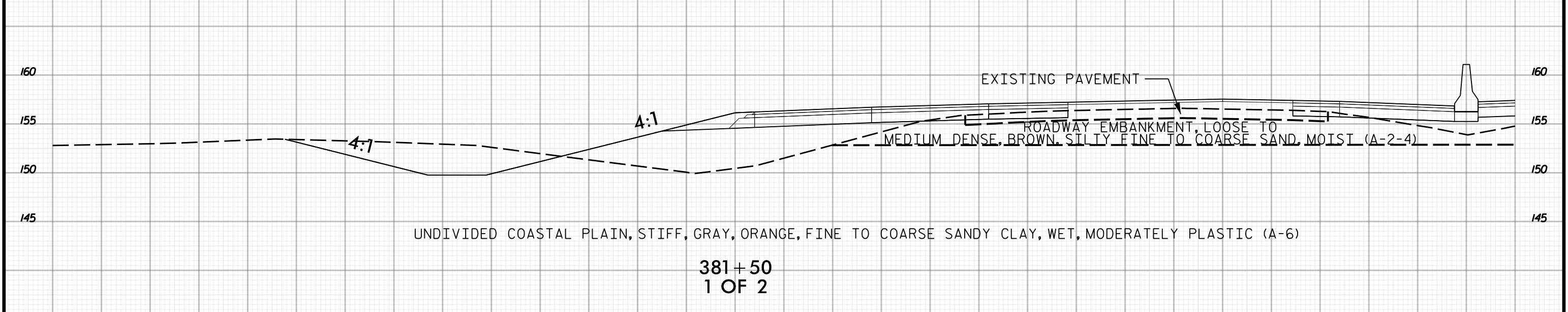
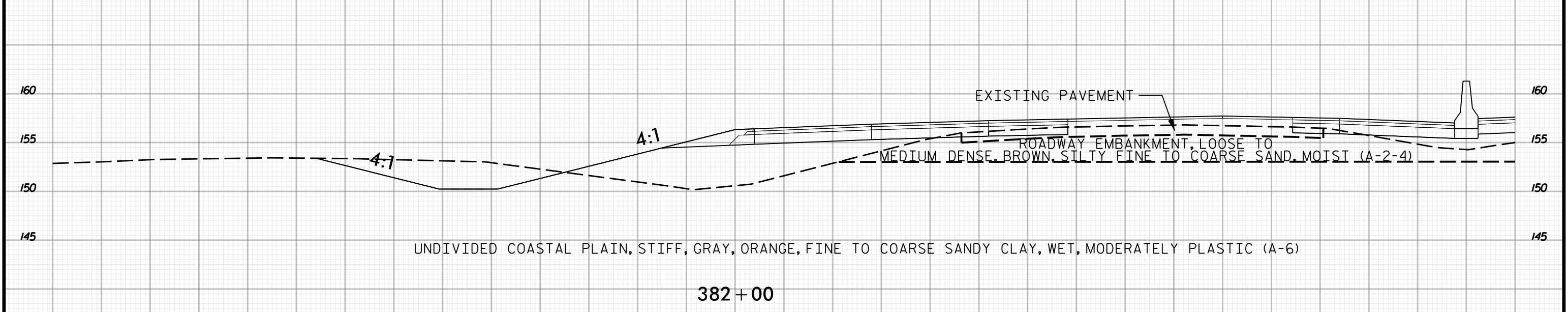
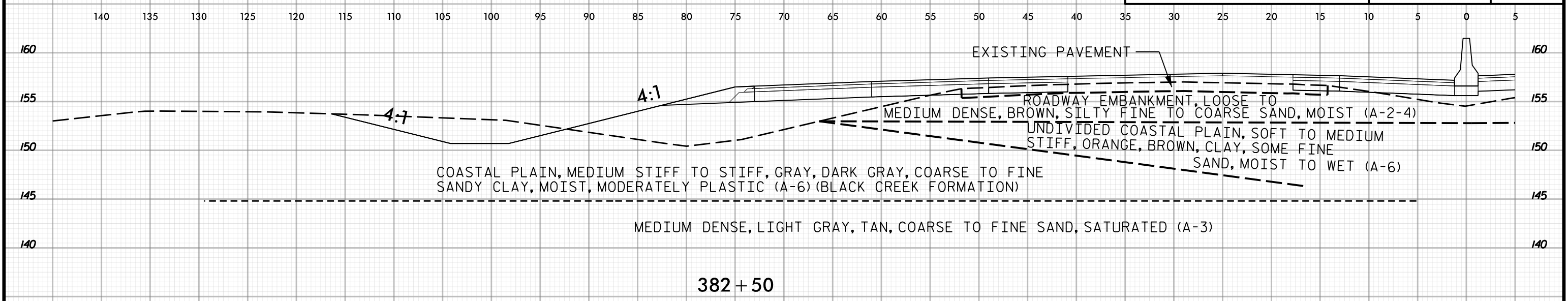

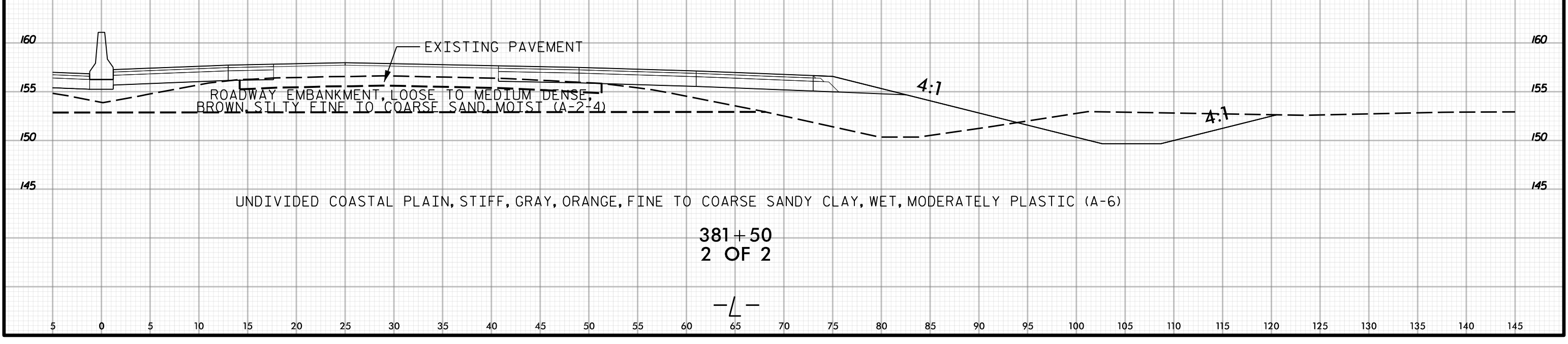
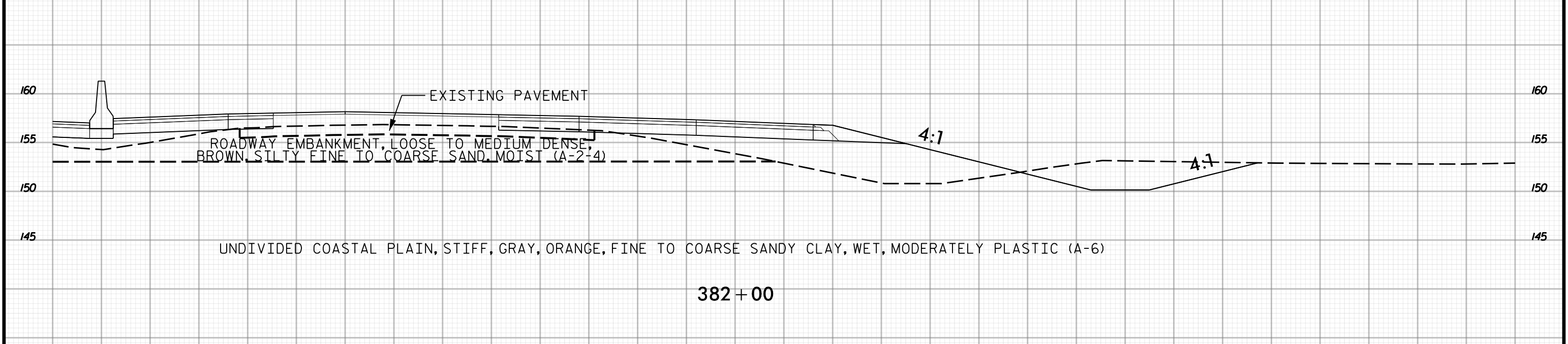
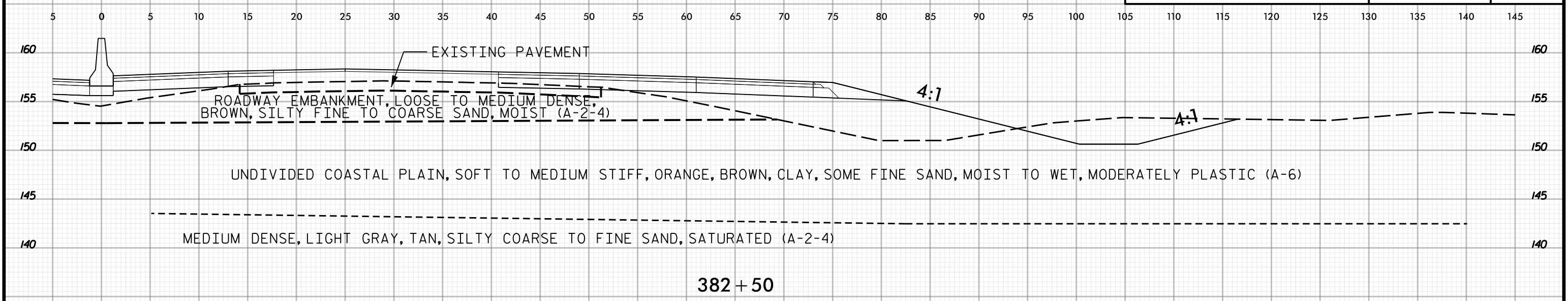

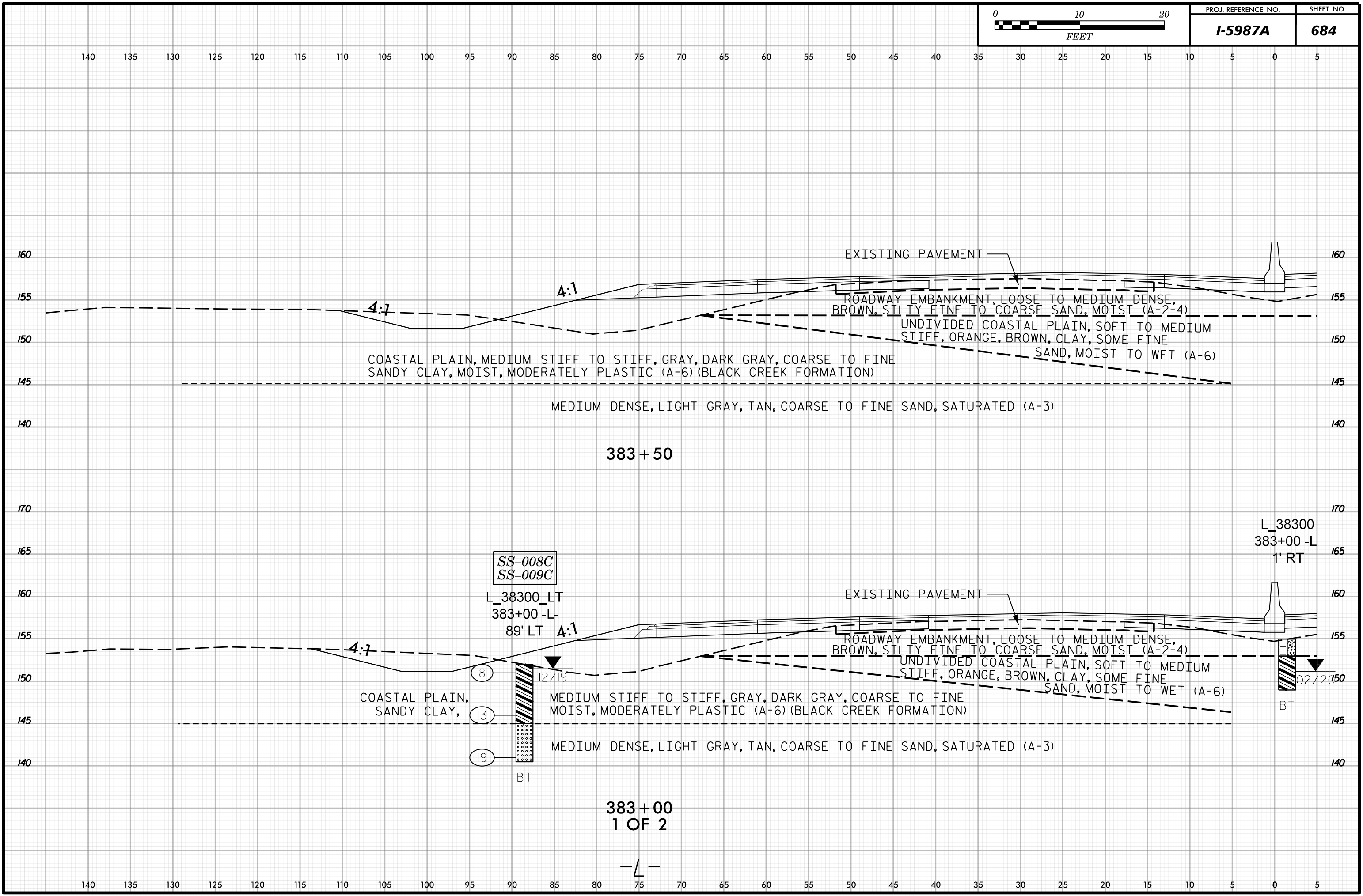

383 + 50

383 + 00
1 OF 2

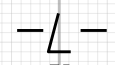



5 0 5 10 15 20 25 30 35 40 45 50 55 60 65 70 75 80 85 90 95 100 105 110 115 120 125 130 135 140 145

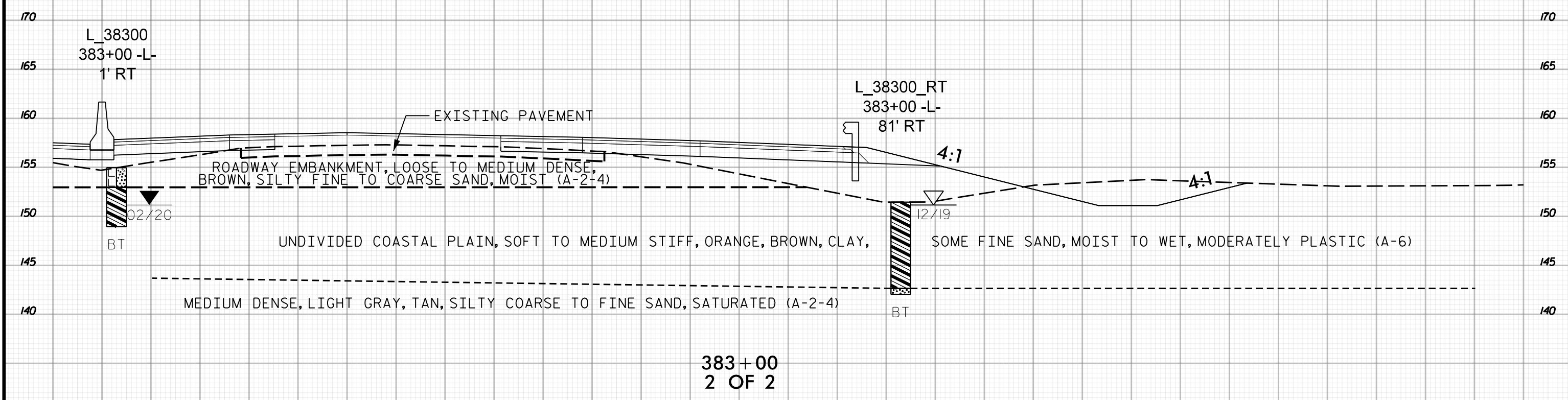
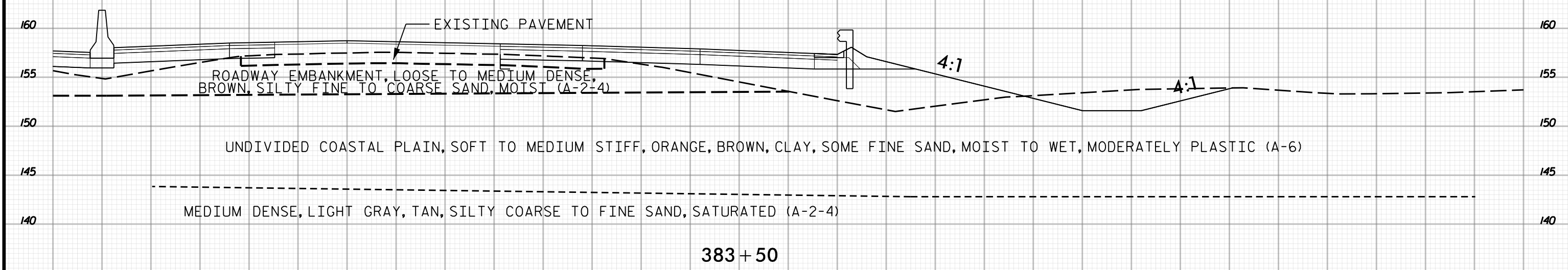

5 0 5 10 15 20 25 30 35 40 45 50 55 60 65 70 75 80 85 90 95 100 105 110 115 120 125 130 135 140 145



140 135 130 125 120 115 110 105 100 95 90 85 80 75 70 65 60 55 50 45 40 35 30 25 20 15 10 5 0 5

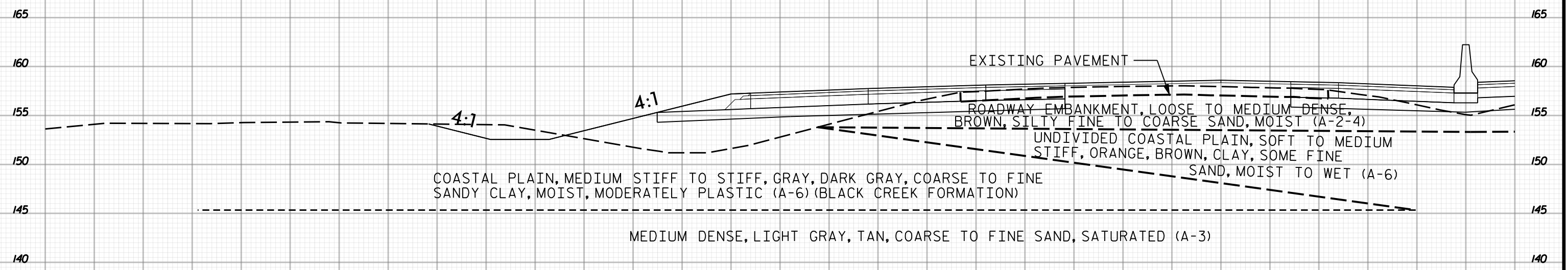

384+50

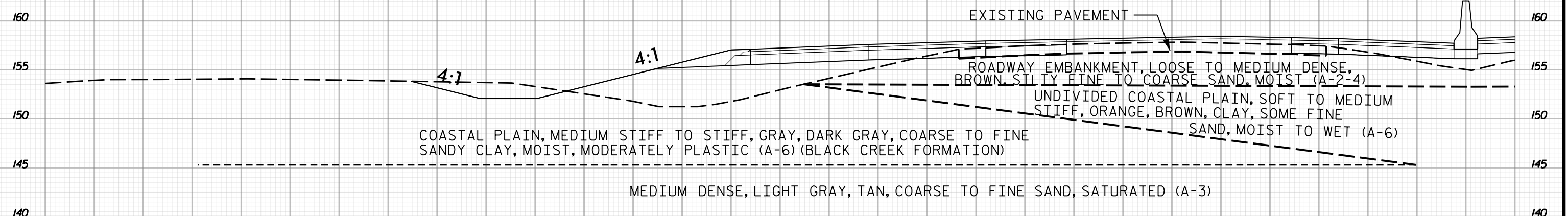

384+00
1 OF 2

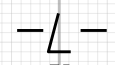

140 135 130 125 120 115 110 105 100 95 90 85 80 75 70 65 60 55 50 45 40 35 30 25 20 15 10 5 0 5



5 0 5 10 15 20 25 30 35 40 45 50 55 60 65 70 75 80 85 90 95 100 105 110 115 120 125 130 135 140 145

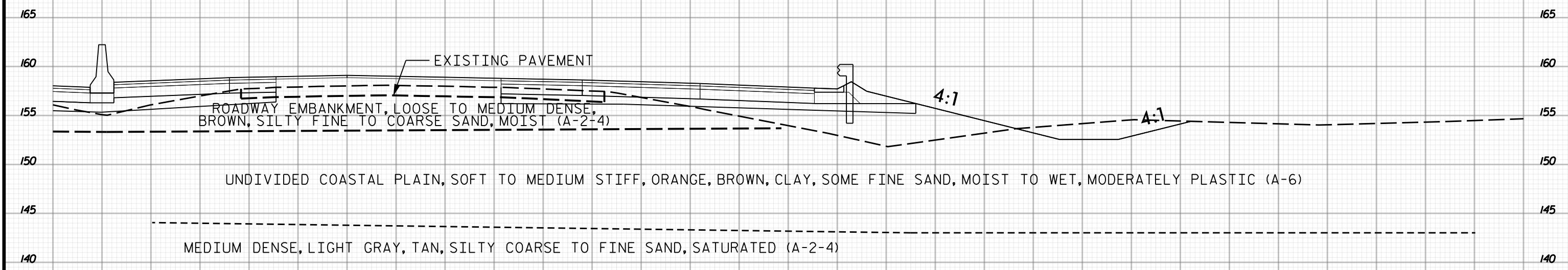

384+50

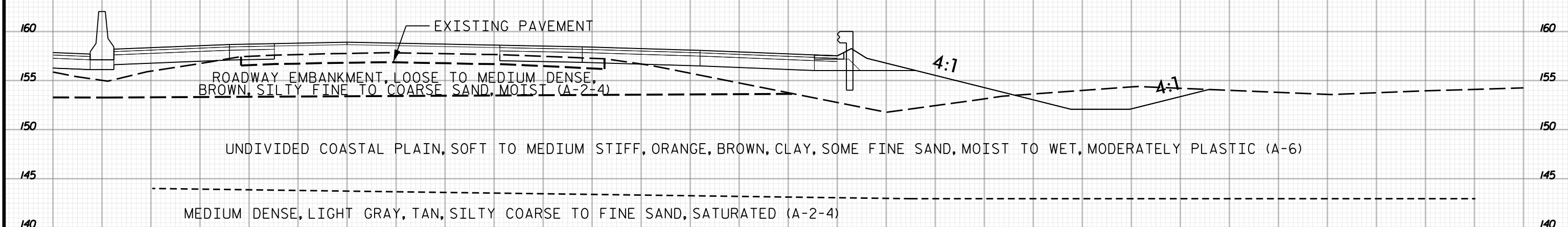

384+00
2 OF 2

5 0 5 10 15 20 25 30 35 40 45 50 55 60 65 70 75 80 85 90 95 100 105 110 115 120 125 130 135 140 145



140 135 130 125 120 115 110 105 100 95 90 85 80 75 70 65 60 55 50 45 40 35 30 25 20 15 10 5 0 5

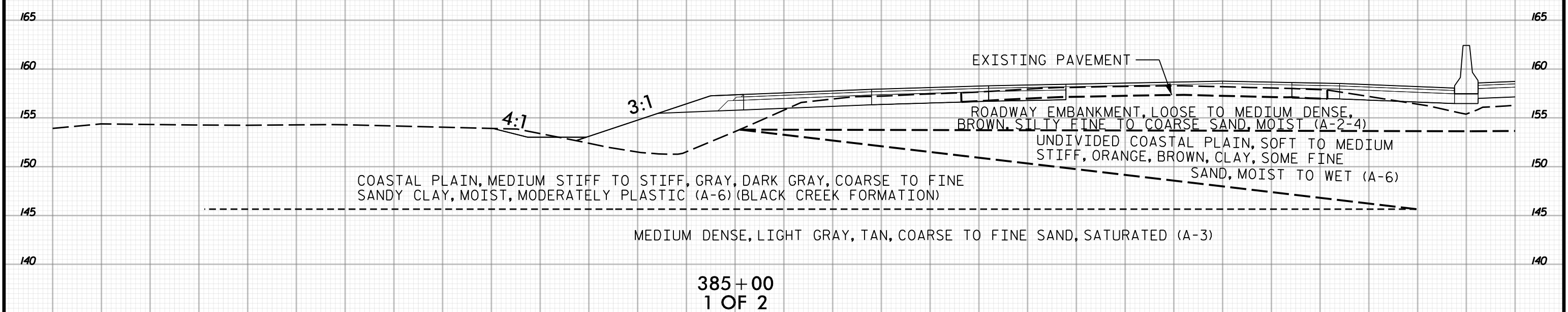
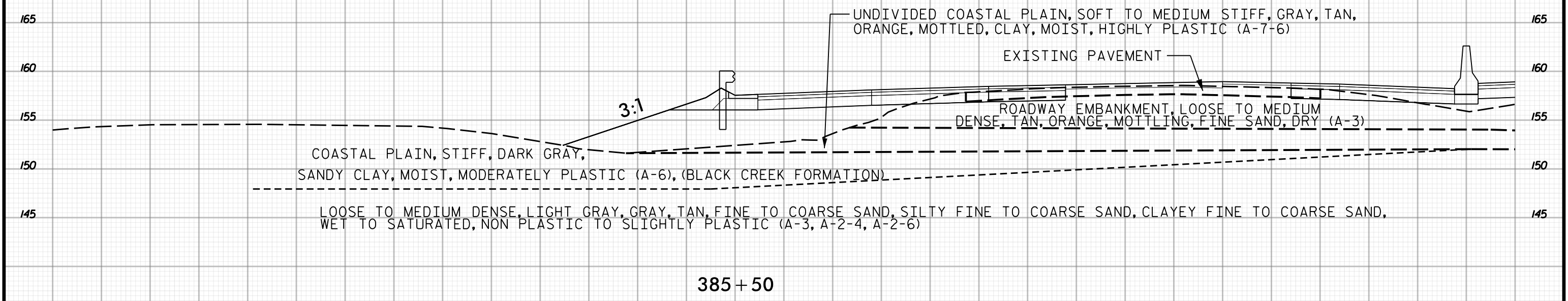

140 135 130 125 120 115 110 105 100 95 90 85 80 75 70 65 60 55 50 45 40 35 30 25 20 15 10 5 0 5

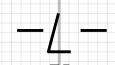



5 0 5 10 15 20 25 30 35 40 45 50 55 60 65 70 75 80 85 90 95 100 105 110 115 120 125 130 135 140 145

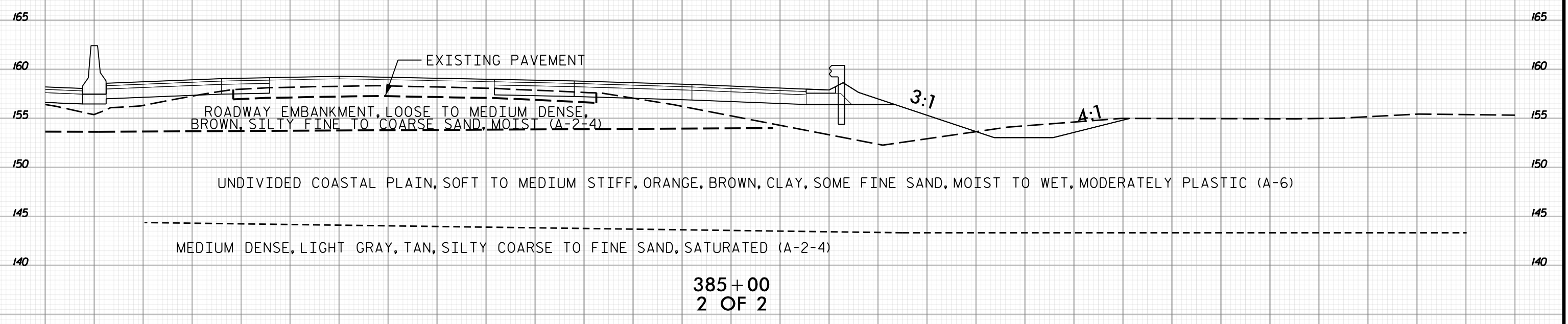
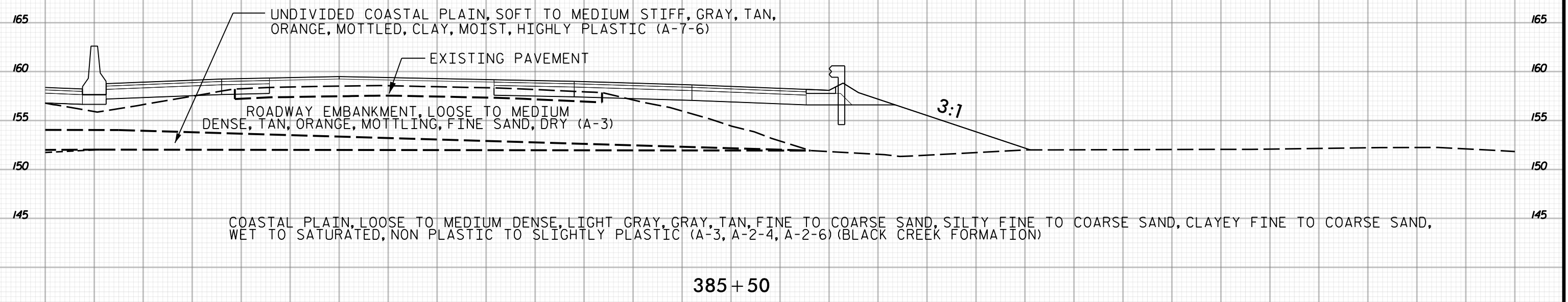

5 0 5 10 15 20 25 30 35 40 45 50 55 60 65 70 75 80 85 90 95 100 105 110 115 120 125 130 135 140 145



140 135 130 125 120 115 110 105 100 95 90 85 80 75 70 65 60 55 50 45 40 35 30 25 20 15 10 5 0 5

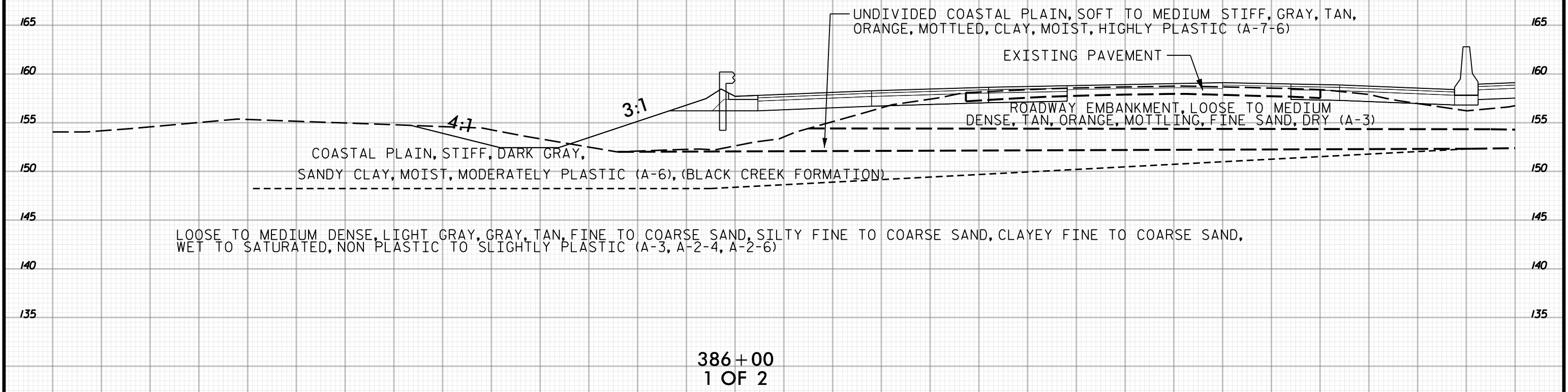
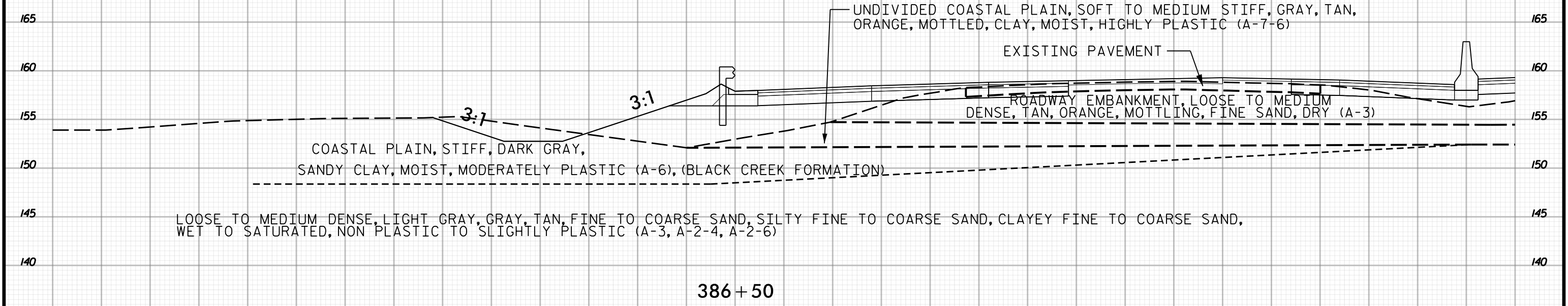

140 135 130 125 120 115 110 105 100 95 90 85 80 75 70 65 60 55 50 45 40 35 30 25 20 15 10 5 0 5



5 0 5 10 15 20 25 30 35 40 45 50 55 60 65 70 75 80 85 90 95 100 105 110 115 120 125 130 135 140 145

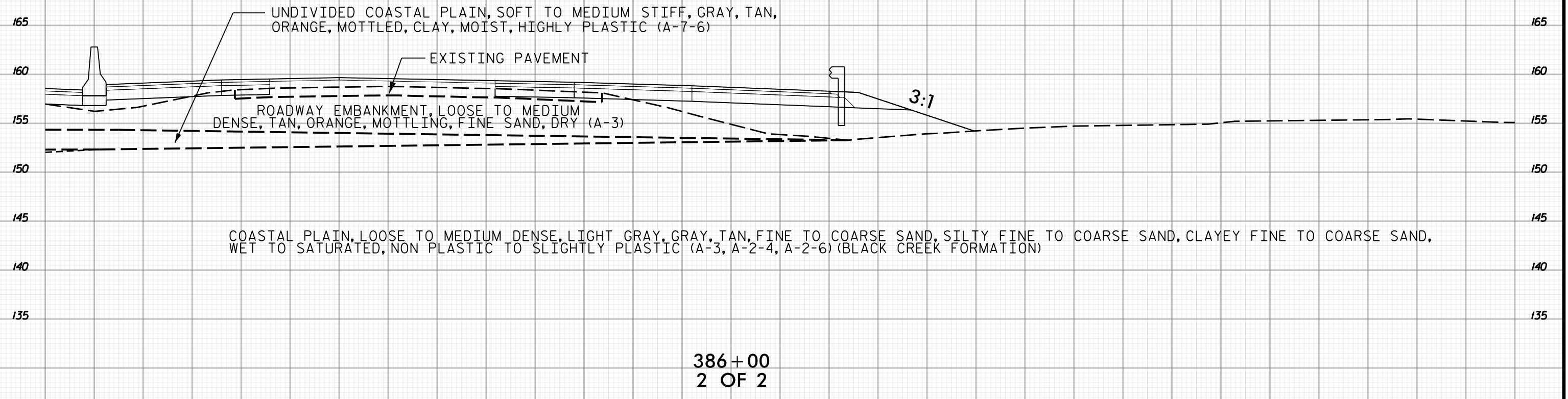
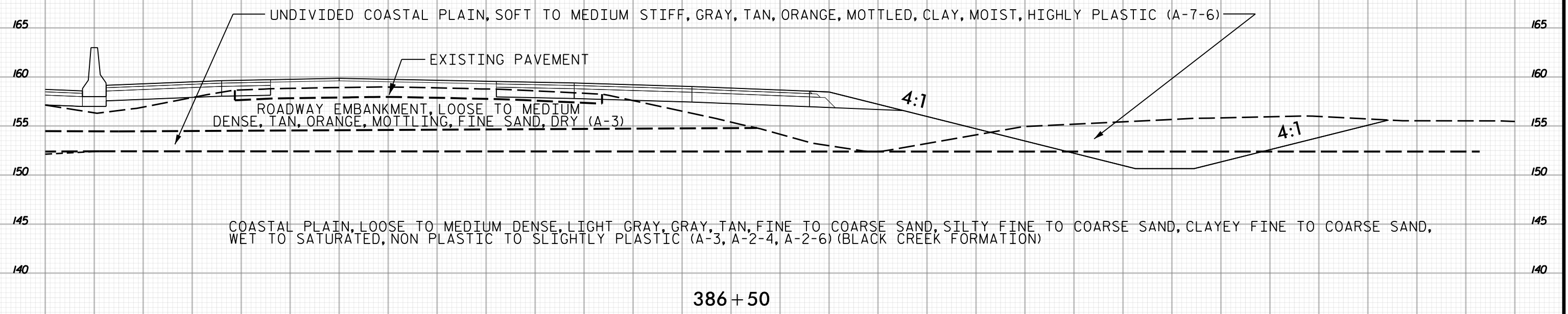

5 0 5 10 15 20 25 30 35 40 45 50 55 60 65 70 75 80 85 90 95 100 105 110 115 120 125 130 135 140 145



140 135 130 125 120 115 110 105 100 95 90 85 80 75 70 65 60 55 50 45 40 35 30 25 20 15 10 5 0 5

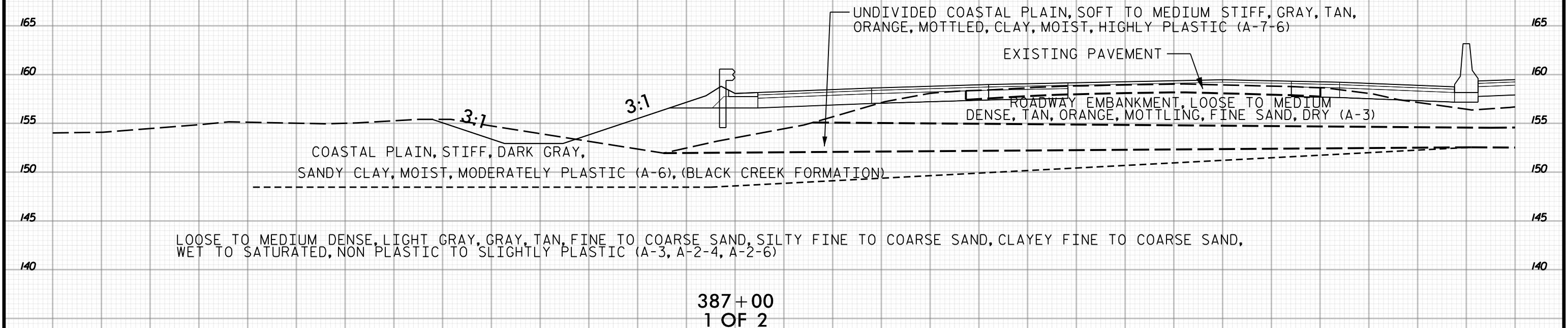
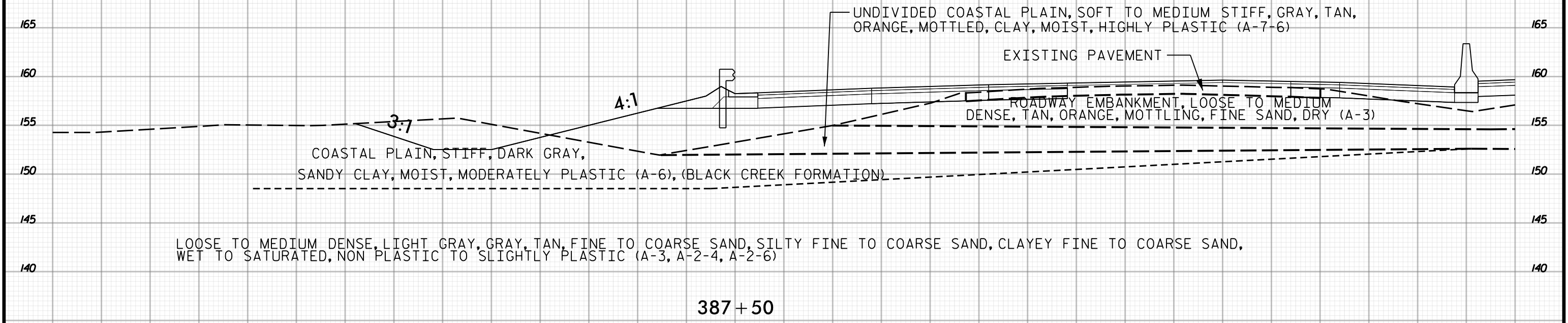

140 135 130 125 120 115 110 105 100 95 90 85 80 75 70 65 60 55 50 45 40 35 30 25 20 15 10 5 0 5

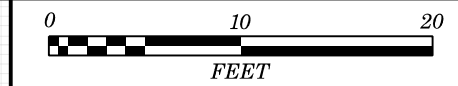

5 0 5 10 15 20 25 30 35 40 45 50 55 60 65 70 75 80 85 90 95 100 105 110 115 120 125 130 135 140 145

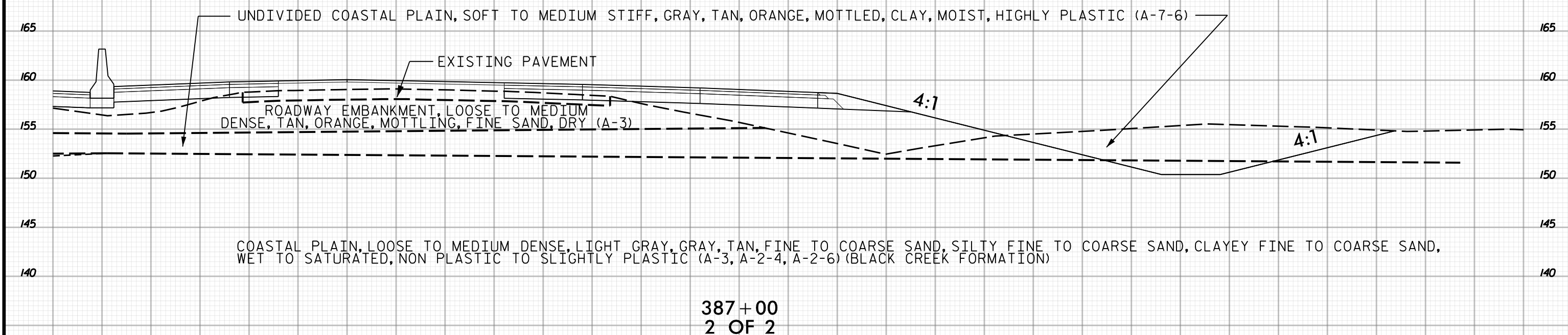
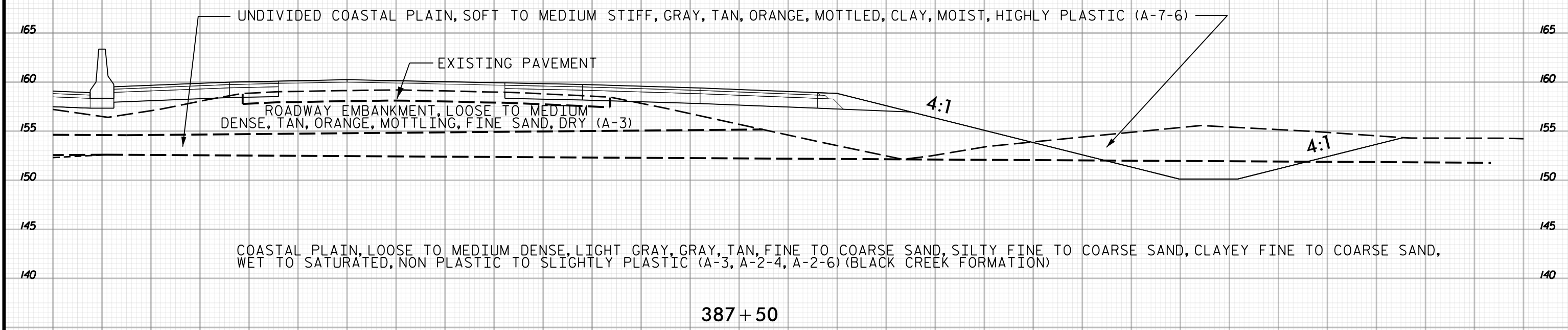

5 0 5 10 15 20 25 30 35 40 45 50 55 60 65 70 75 80 85 90 95 100 105 110 115 120 125 130 135 140 145

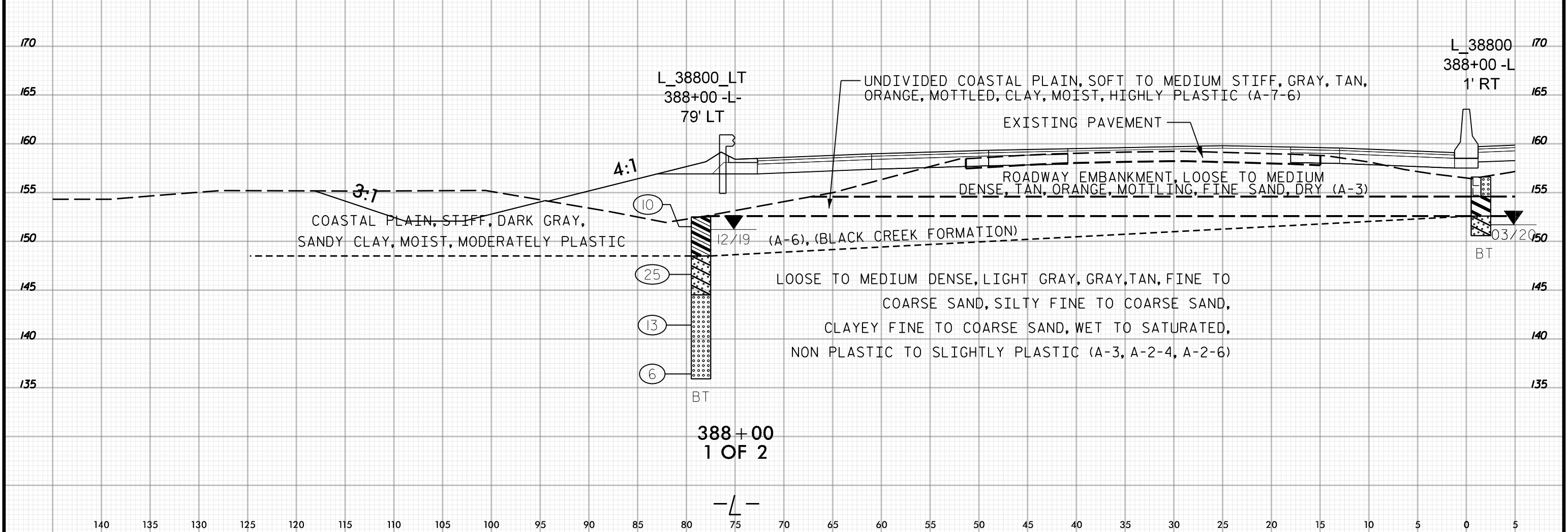
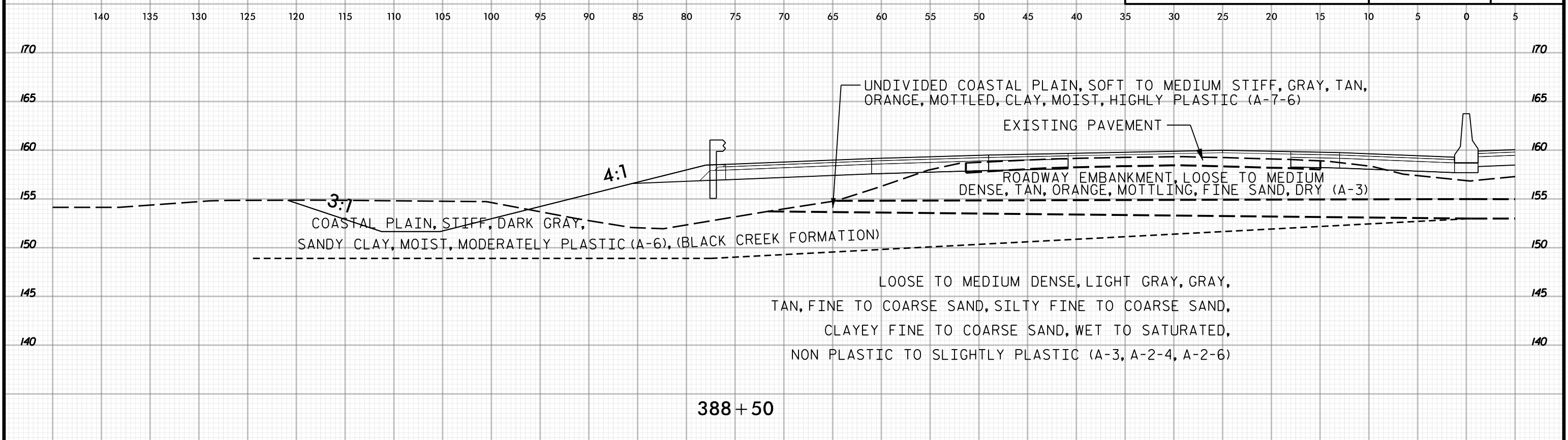
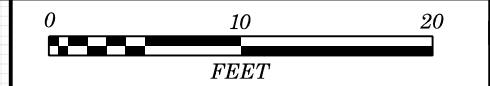

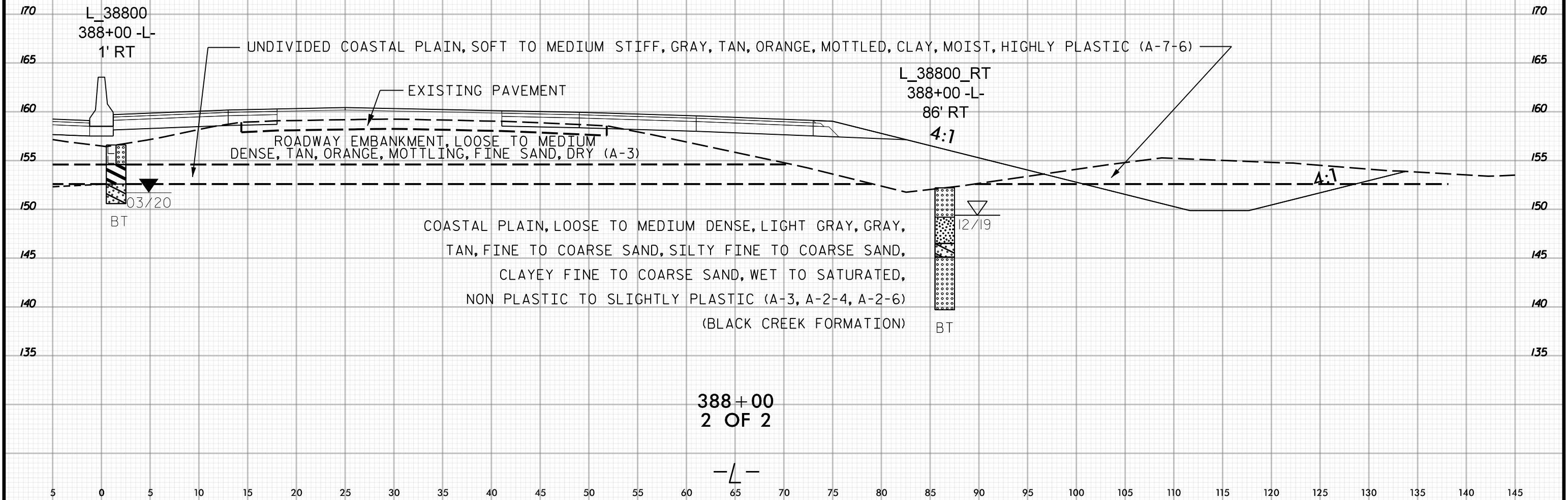
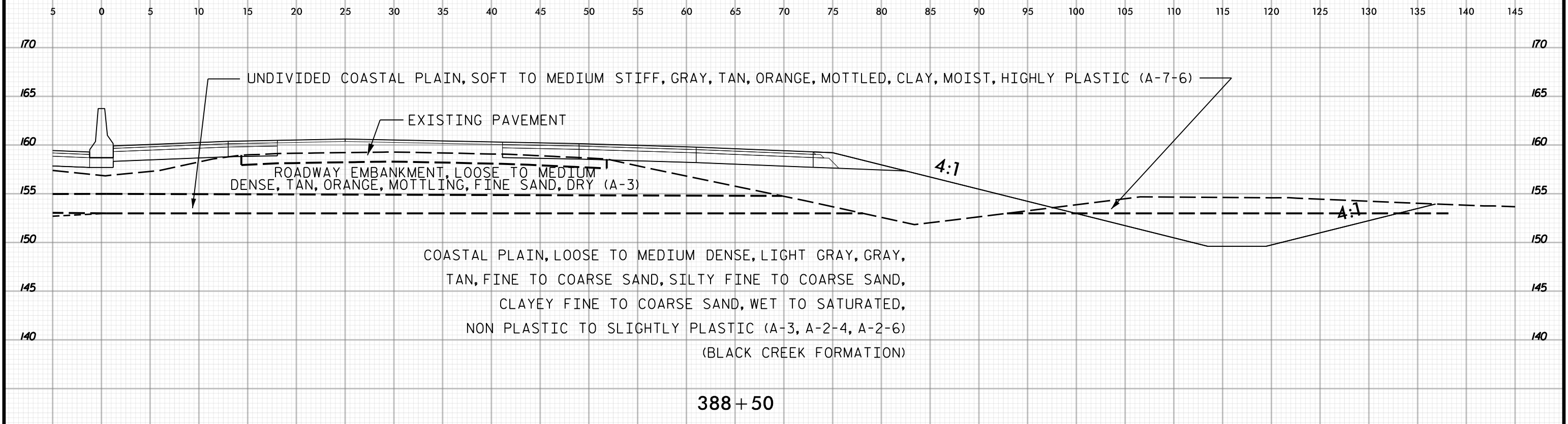



140 135 130 125 120 115 110 105 100 95 90 85 80 75 70 65 60 55 50 45 40 35 30 25 20 15 10 5 0 5

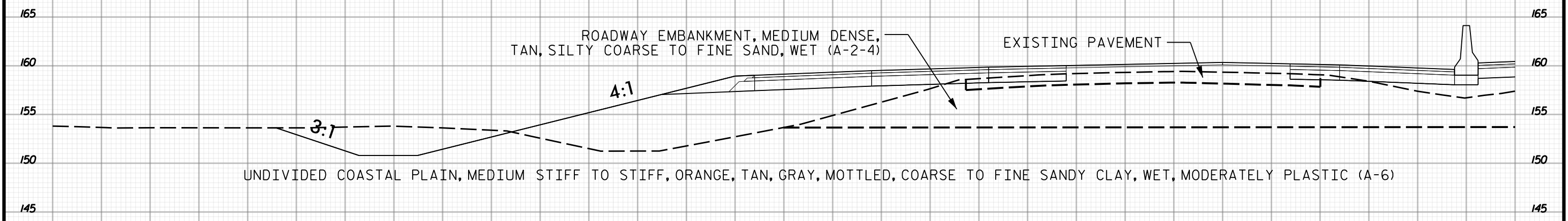

389+50

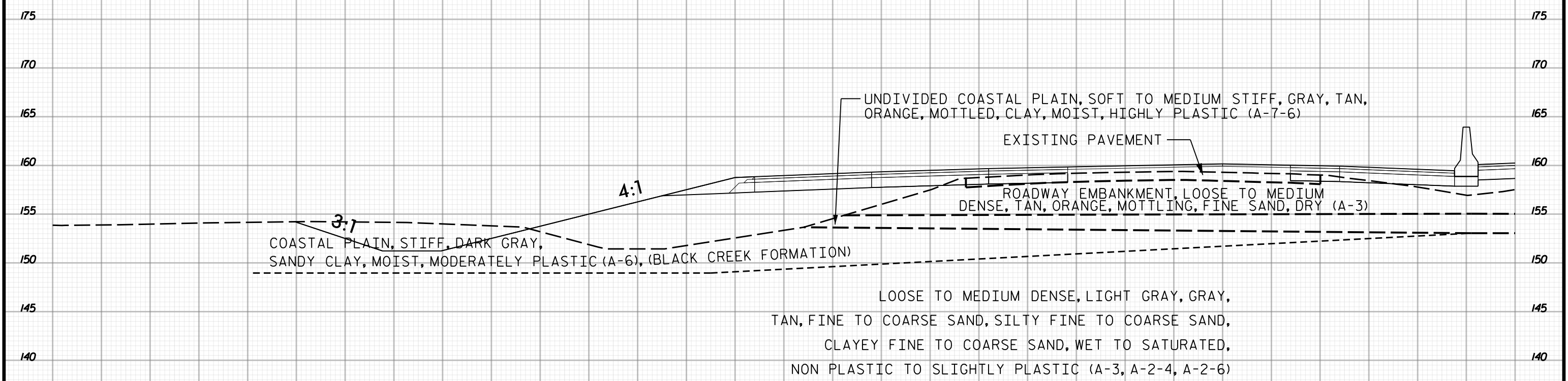

389+00
1 OF 2

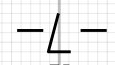

140 135 130 125 120 115 110 105 100 95 90 85 80 75 70 65 60 55 50 45 40 35 30 25 20 15 10 5 0 5



5 0 5 10 15 20 25 30 35 40 45 50 55 60 65 70 75 80 85 90 95 100 105 110 115 120 125 130 135 140 145

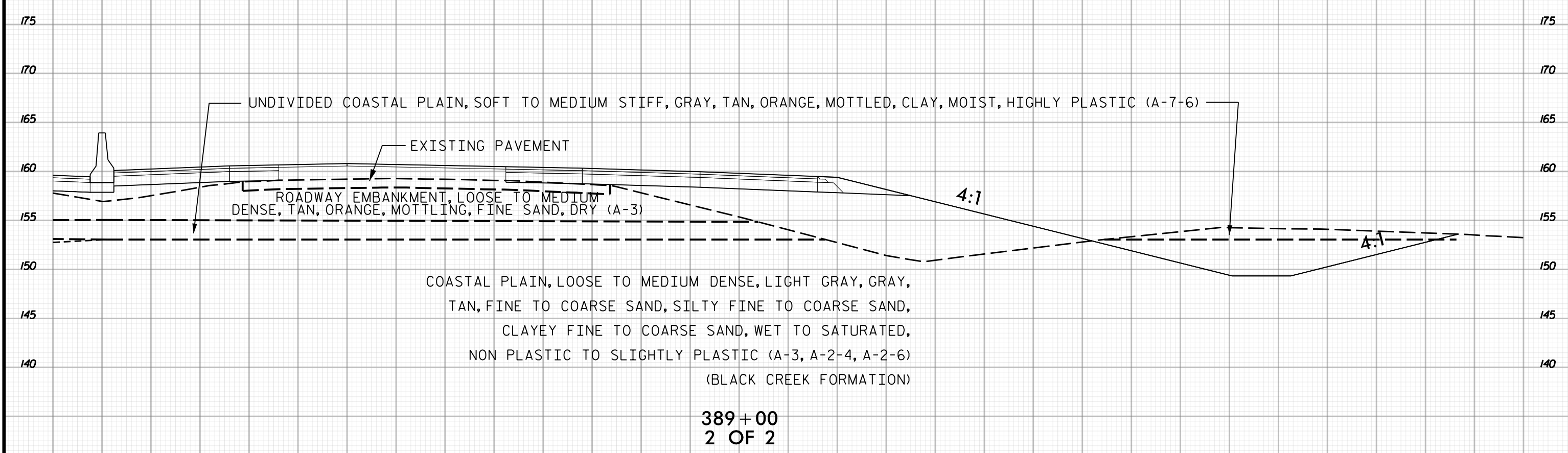
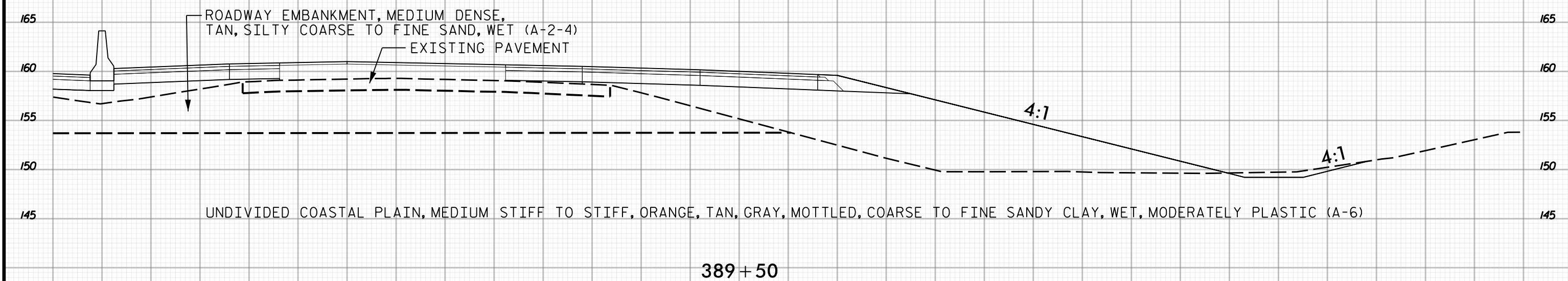

5 0 5 10 15 20 25 30 35 40 45 50 55 60 65 70 75 80 85 90 95 100 105 110 115 120 125 130 135 140 145



140 135 130 125 120 115 110 105 100 95 90 85 80 75 70 65 60 55 50 45 40 35 30 25 20 15 10 5 0 5

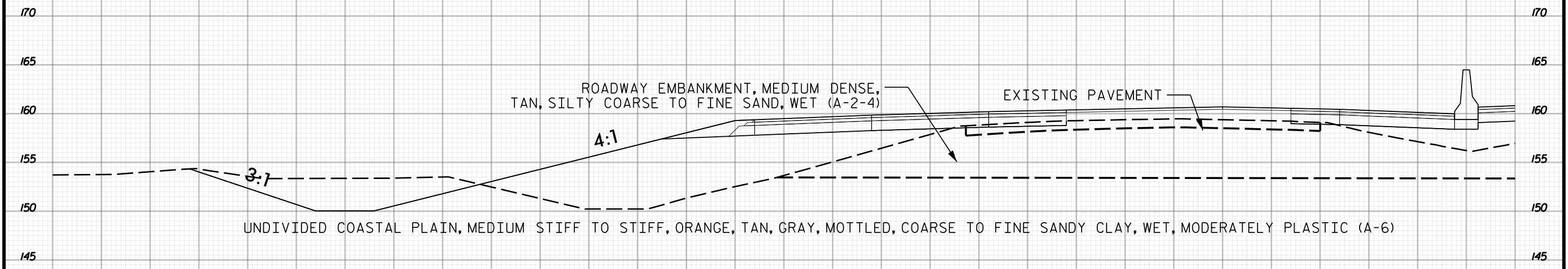

390+50

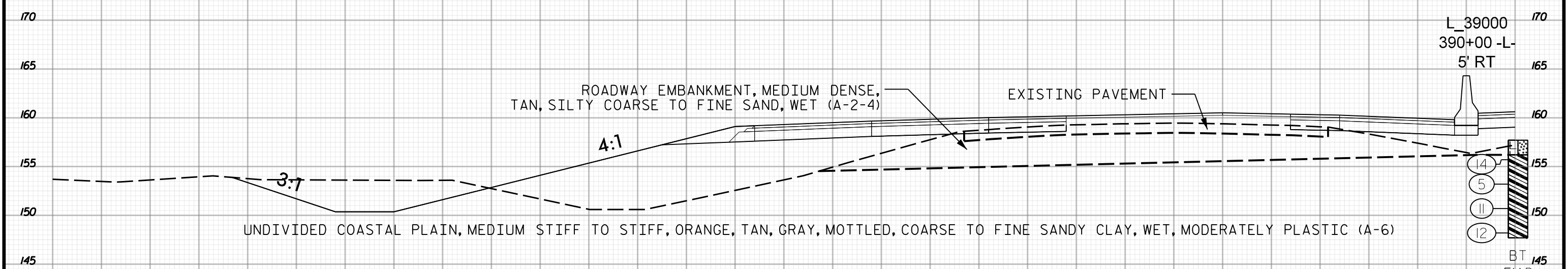

390+00
1 OF 2

L_39000
390+00 -L-
5' RT

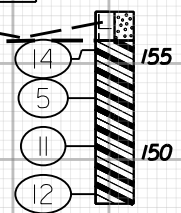

BT
FIAD
02/21

140 135 130 125 120 115 110 105 100 95 90 85 80 75 70 65 60 55 50 45 40 35 30 25 20 15 10 5 0 5

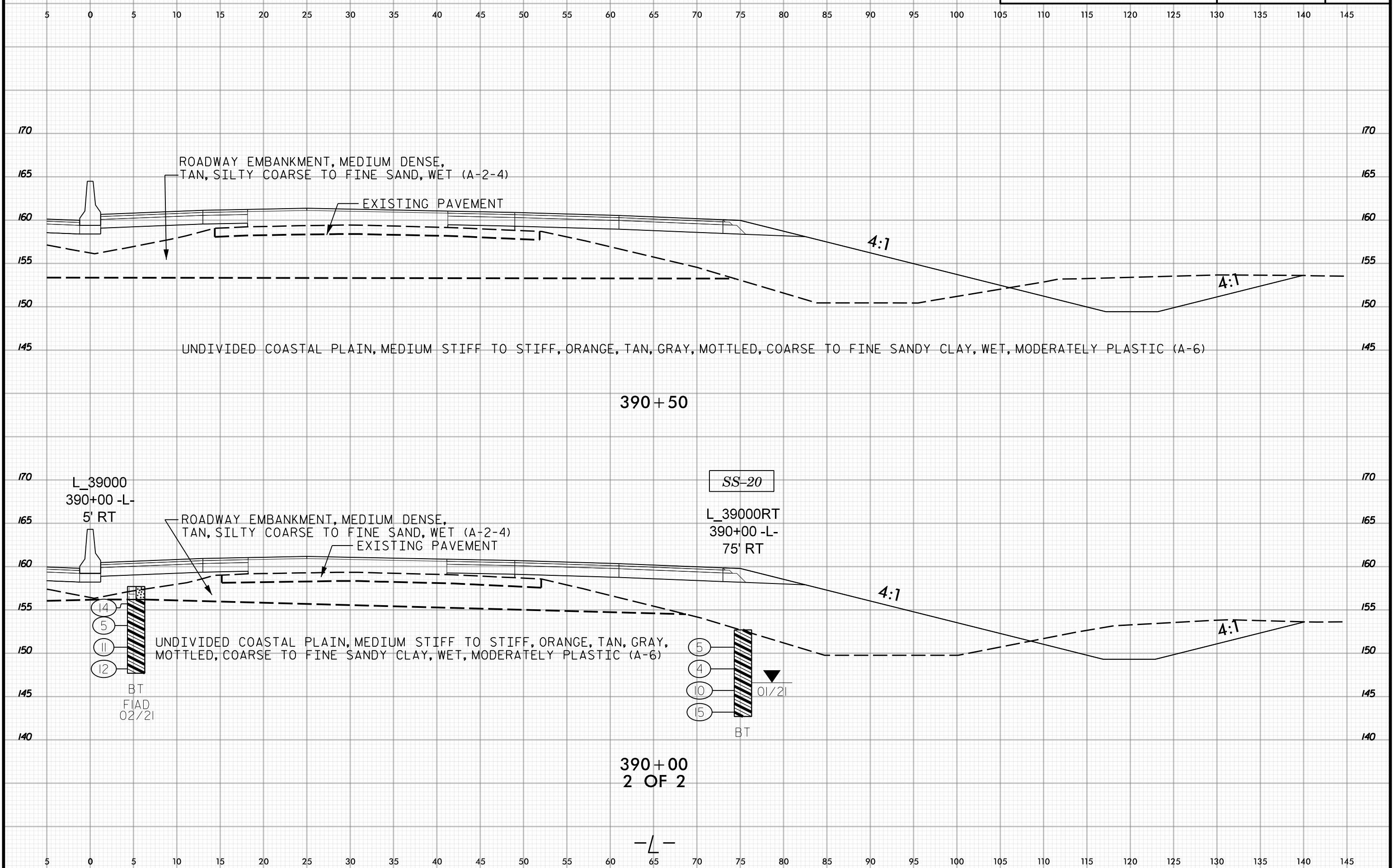



140 135 130 125 120 115 110 105 100 95 90 85 80 75 70 65 60 55 50 45 40 35 30 25 20 15 10 5 0 5

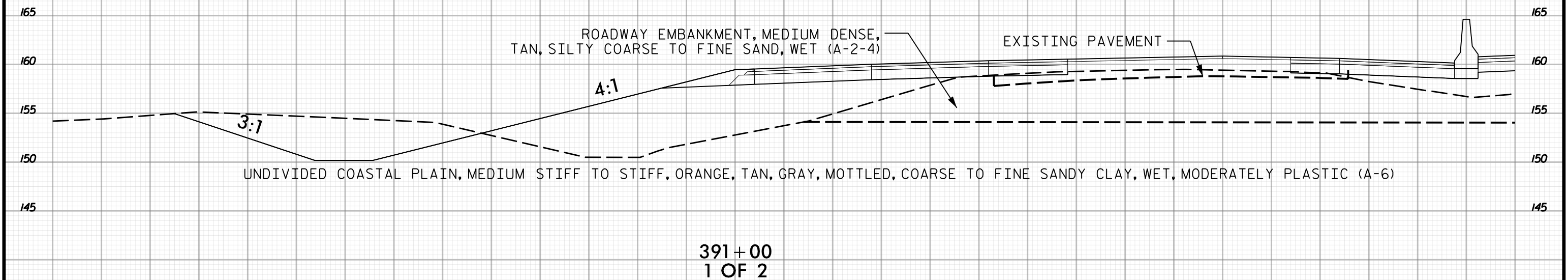
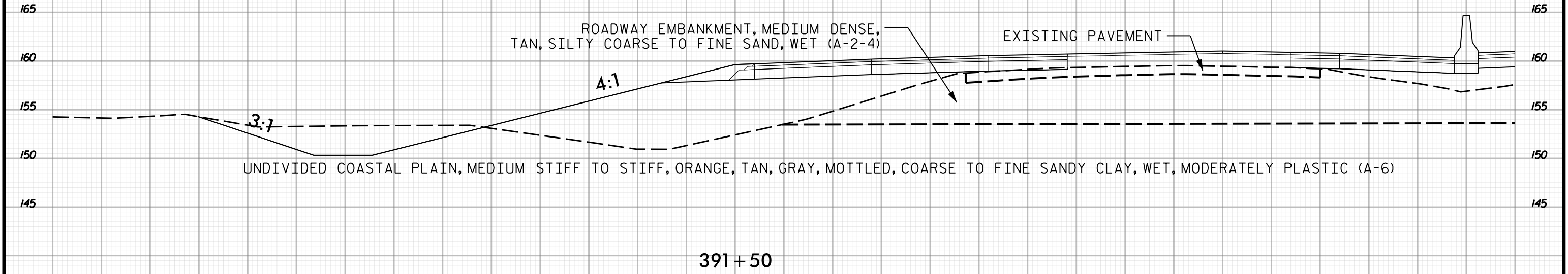

140 135 130 125 120 115 110 105 100 95 90 85 80 75 70 65 60 55 50 45 40 35 30 25 20 15 10 5 0 5

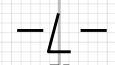



5 0 5 10 15 20 25 30 35 40 45 50 55 60 65 70 75 80 85 90 95 100 105 110 115 120 125 130 135 140 145

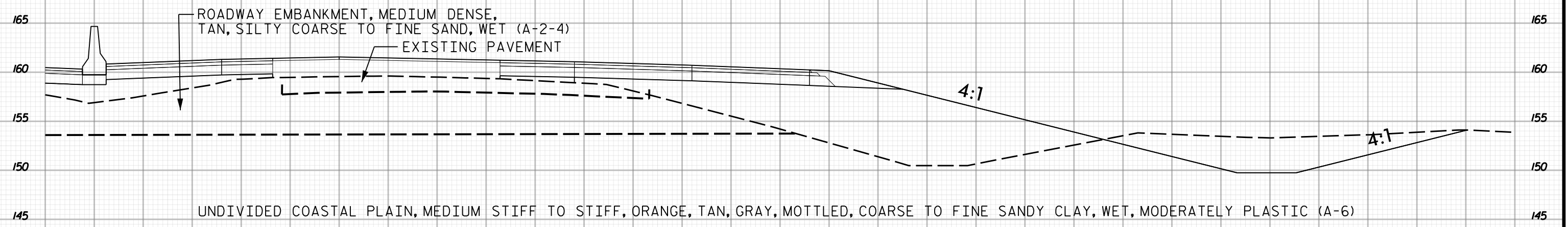

391+50



391+00
2 OF 2

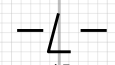

5 0 5 10 15 20 25 30 35 40 45 50 55 60 65 70 75 80 85 90 95 100 105 110 115 120 125 130 135 140 145

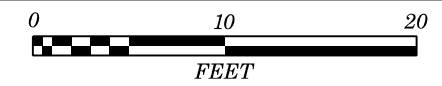

140 135 130 125 120 115 110 105 100 95 90 85 80 75 70 65 60 55 50 45 40 35 30 25 20 15 10 5 0 5

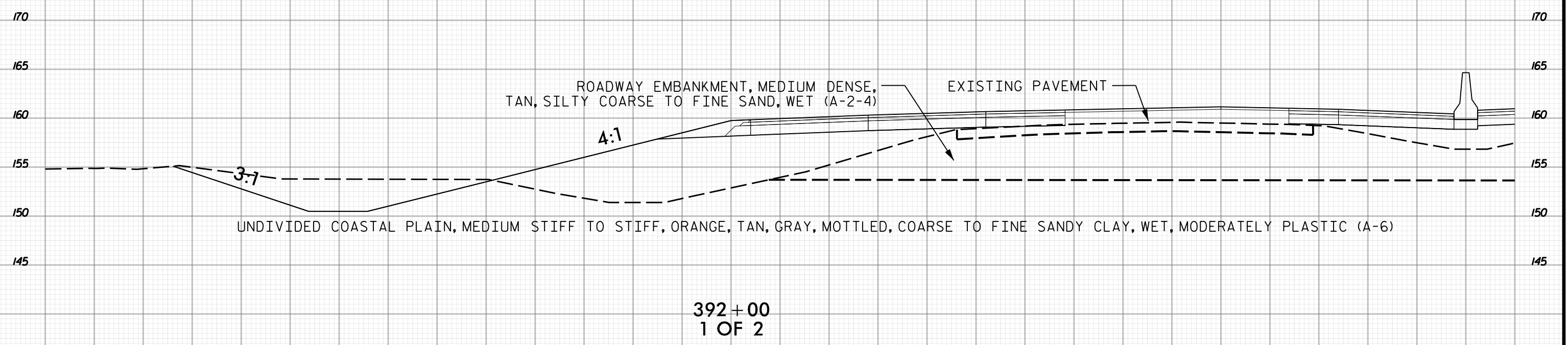
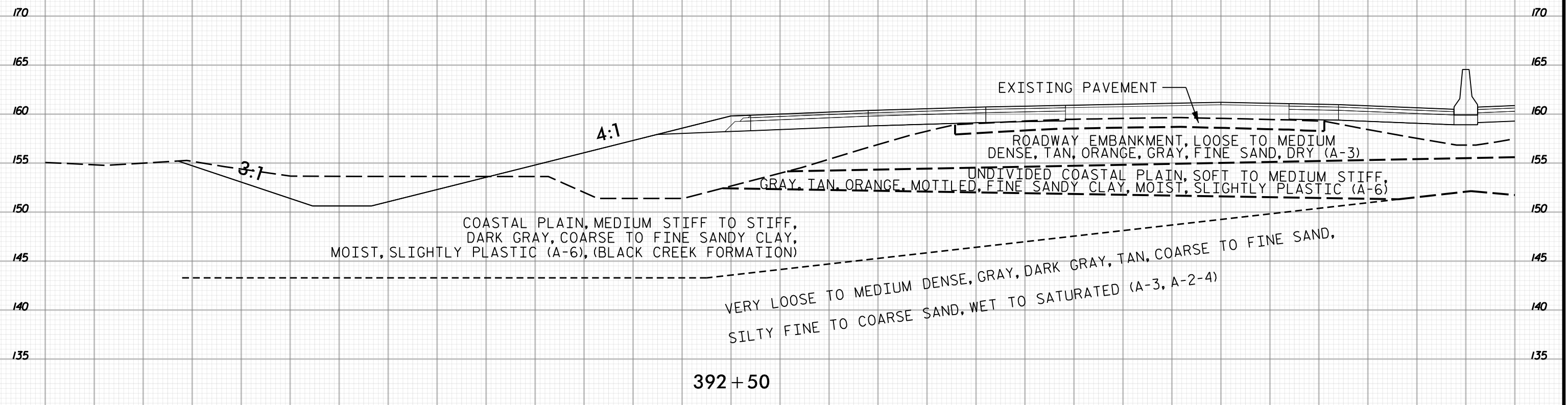

140 135 130 125 120 115 110 105 100 95 90 85 80 75 70 65 60 55 50 45 40 35 30 25 20 15 10 5 0 5

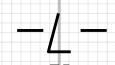



5 0 5 10 15 20 25 30 35 40 45 50 55 60 65 70 75 80 85 90 95 100 105 110 115 120 125 130 135 140 145

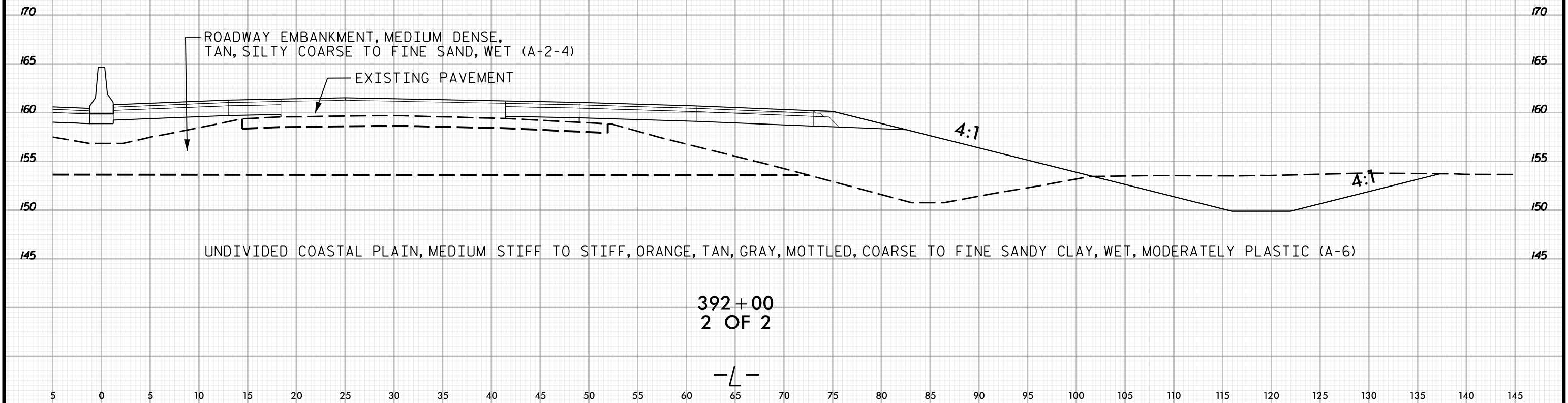
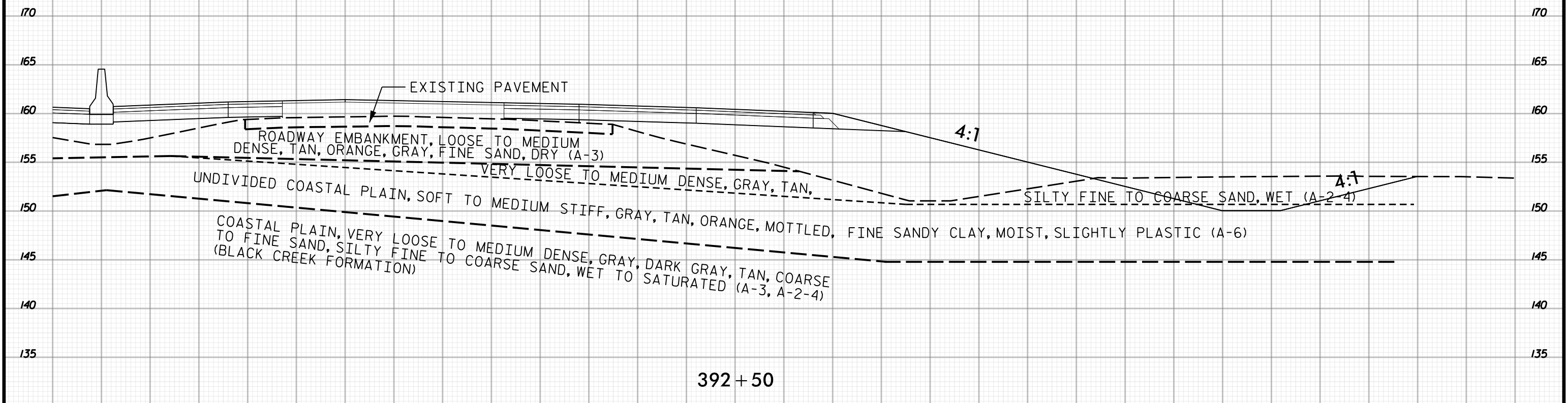

5 0 5 10 15 20 25 30 35 40 45 50 55 60 65 70 75 80 85 90 95 100 105 110 115 120 125 130 135 140 145

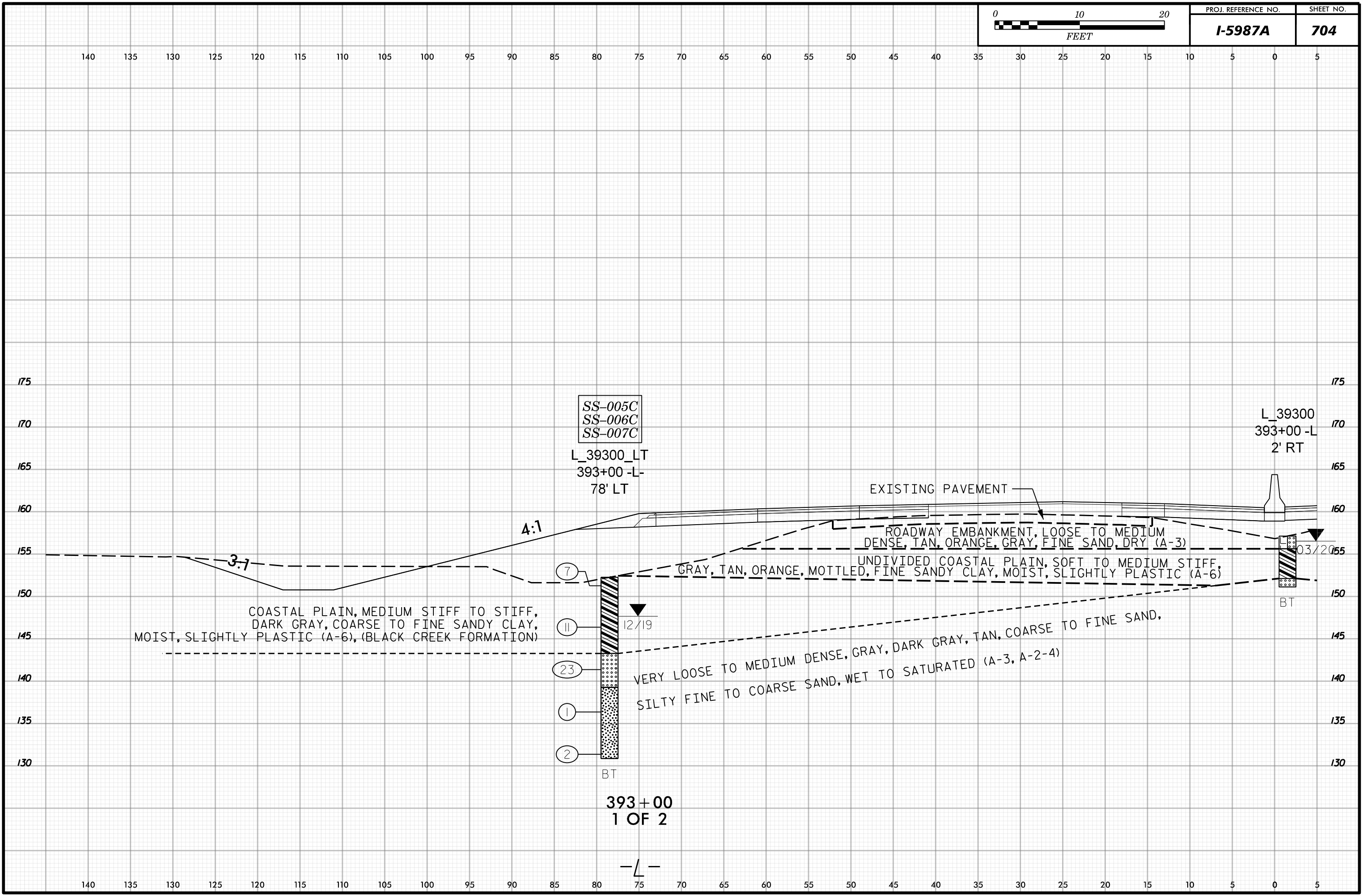

SS-005C
SS-006C
SS-007C

L_39300_LT
393+00 -L-
78' LT

L_39300
393+00 -L
2' RT

EXISTING PAVEMENT

ROADWAY EMBANKMENT, LOOSE TO MEDIUM
DENSE, TAN, ORANGE, GRAY, FINE SAND, DRY (A-3)

UNDIVIDED COASTAL PLAIN, SOFT TO MEDIUM STIFF,
GRAY, TAN, ORANGE, MOTTLED, FINE SANDY CLAY, MOIST, SLIGHTLY PLASTIC (A-6)

COASTAL PLAIN, MEDIUM STIFF TO STIFF,
DARK GRAY, COARSE TO FINE SANDY CLAY,
MOIST, SLIGHTLY PLASTIC (A-6), (BLACK CREEK FORMATION)

VERY LOOSE TO MEDIUM DENSE, GRAY, DARK GRAY, TAN, COARSE TO FINE SAND,
SILTY FINE TO COARSE SAND, WET TO SATURATED (A-3, A-2-4)

7

11

23

1

2

12/19

BT

393+00
1 OF 2

-L-

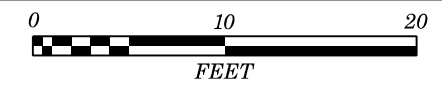

5 0 5 10 15 20 25 30 35 40 45 50 55 60 65 70 75 80 85 90 95 100 105 110 115 120 125 130 135 140 145

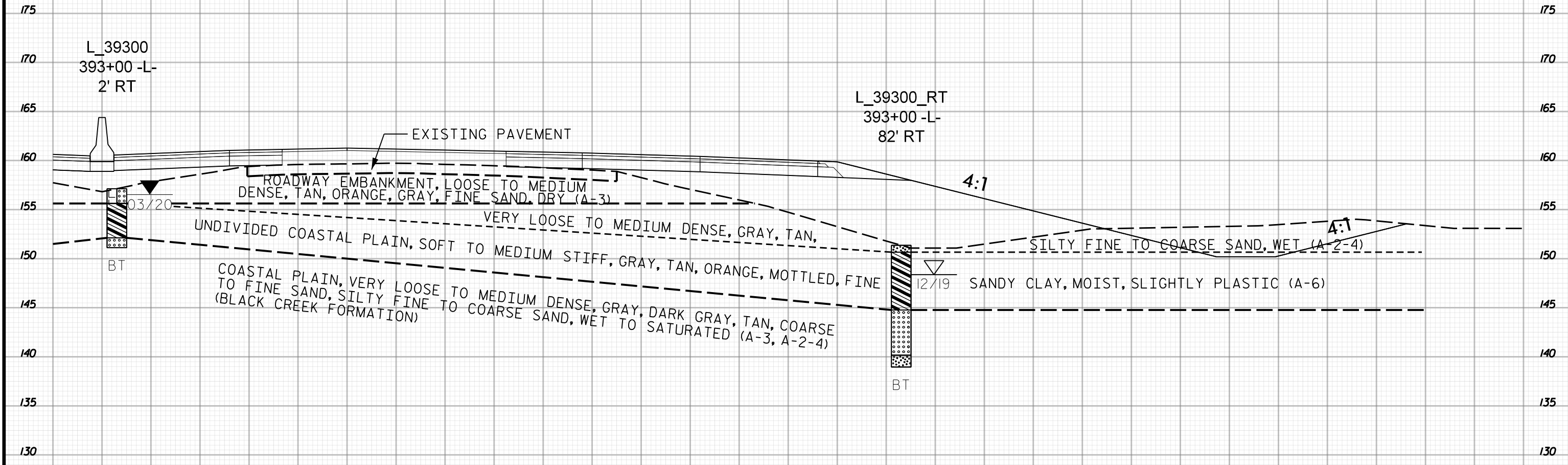

L_39300
393+00 -L-
2' RT

L_39300_RT
393+00 -L-
82' RT

BT

BT

393+00
2 OF 2

-L-

5 0 5 10 15 20 25 30 35 40 45 50 55 60 65 70 75 80 85 90 95 100 105 110 115 120 125 130 135 140 145



140 135 130 125 120 115 110 105 100 95 90 85 80 75 70 65 60 55 50 45 40 35 30 25 20 15 10 5 0 5

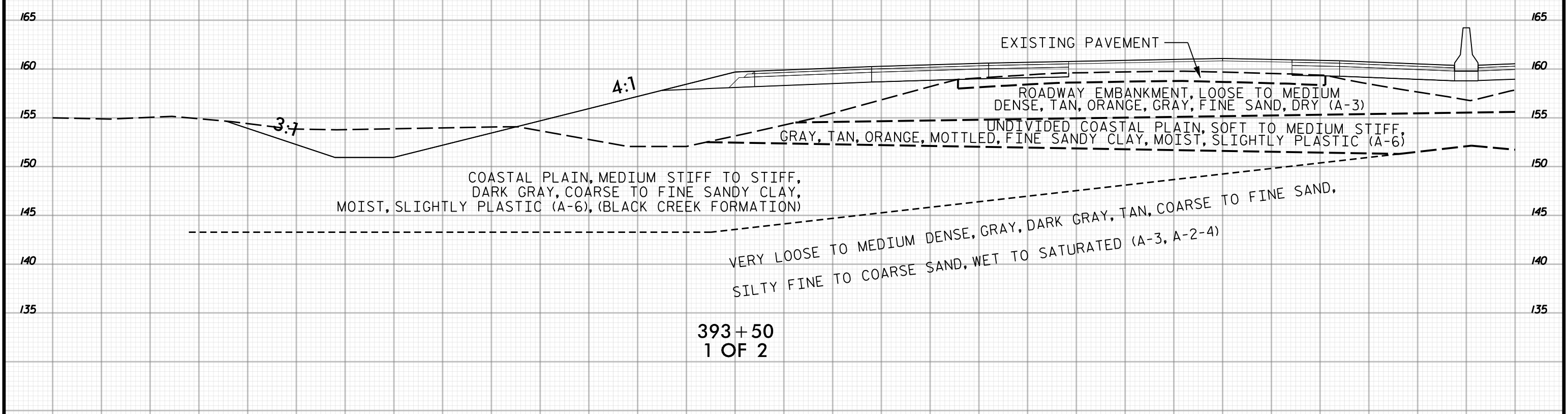
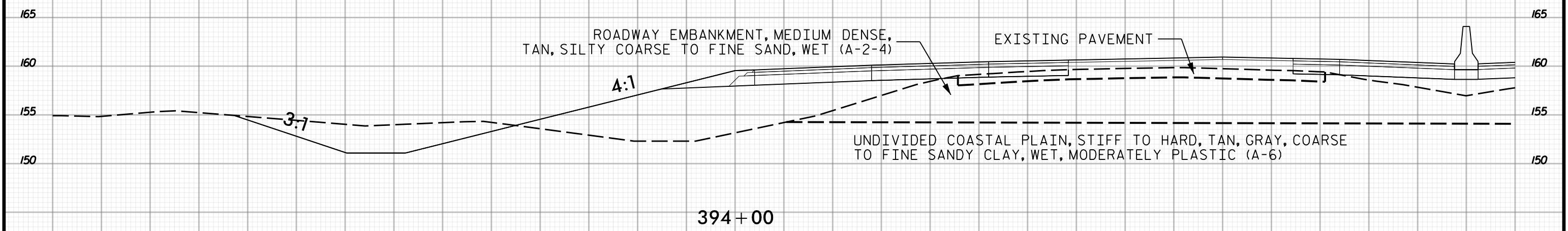

140 135 130 125 120 115 110 105 100 95 90 85 80 75 70 65 60 55 50 45 40 35 30 25 20 15 10 5 0 5



5 0 5 10 15 20 25 30 35 40 45 50 55 60 65 70 75 80 85 90 95 100 105 110 115 120 125 130 135 140 145

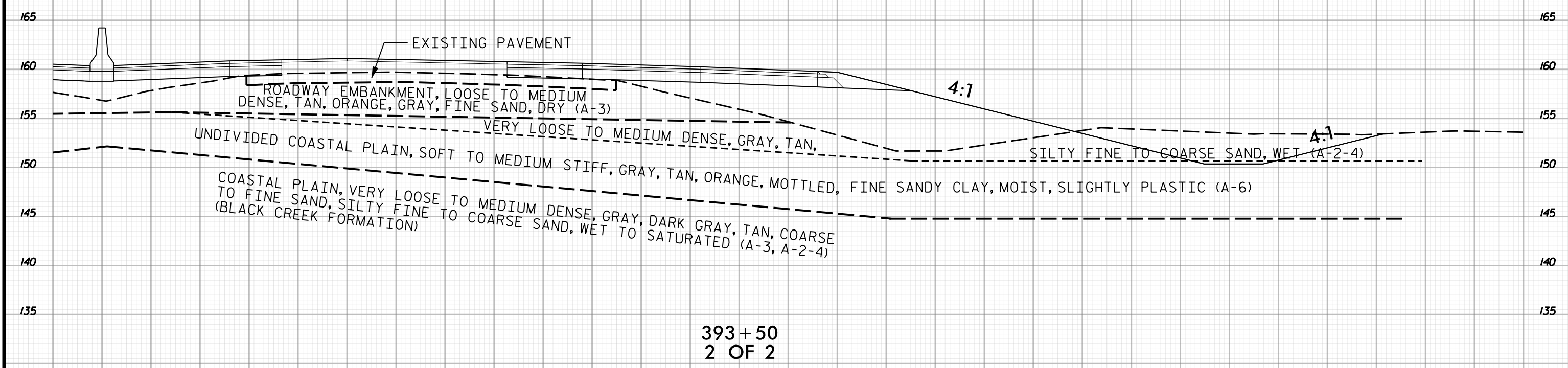
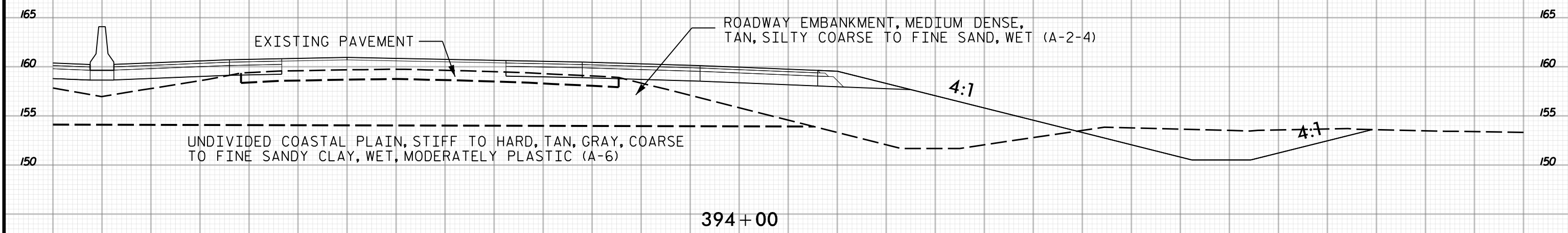

5 0 5 10 15 20 25 30 35 40 45 50 55 60 65 70 75 80 85 90 95 100 105 110 115 120 125 130 135 140 145

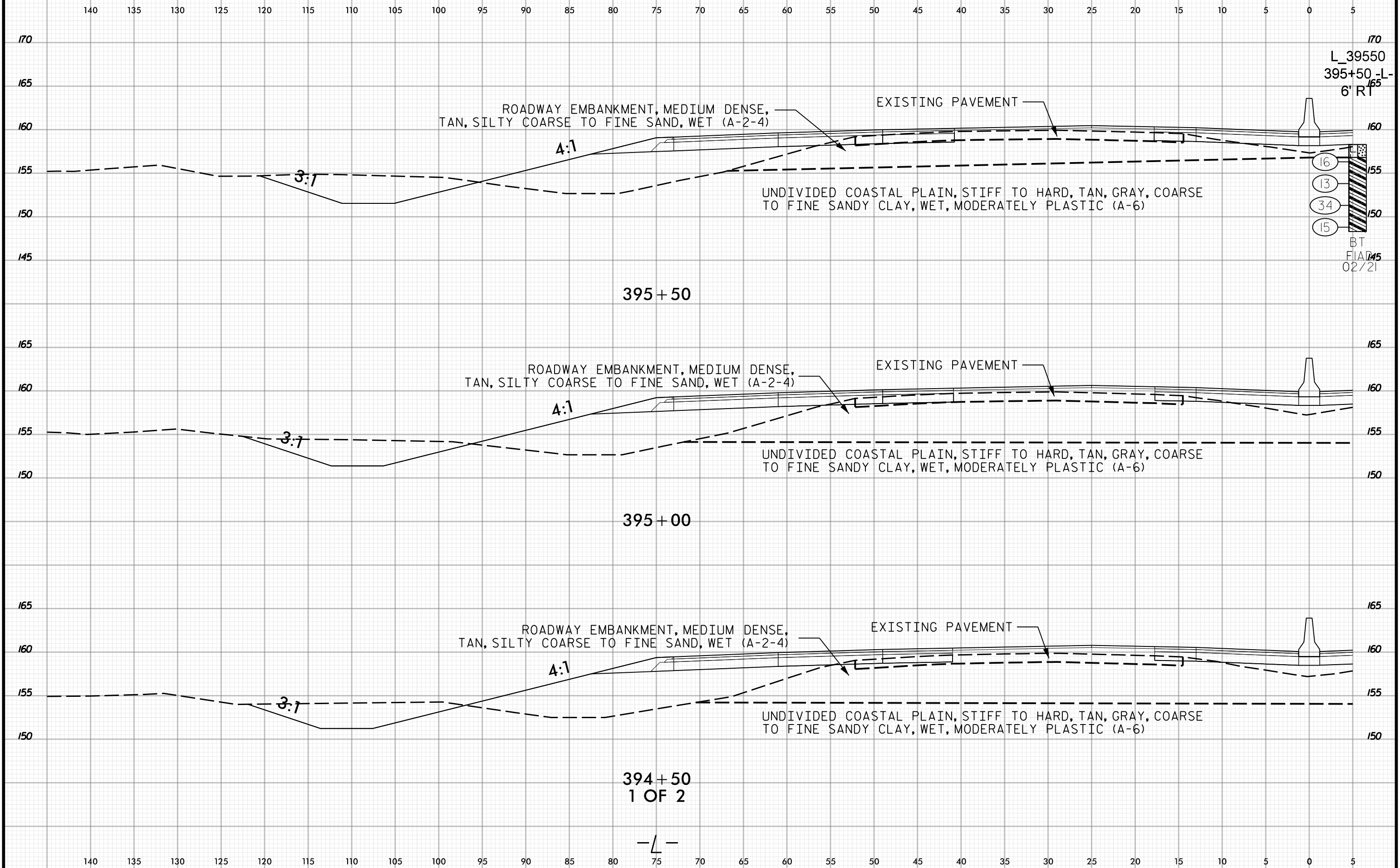

394+50
1 OF 2

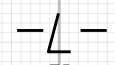

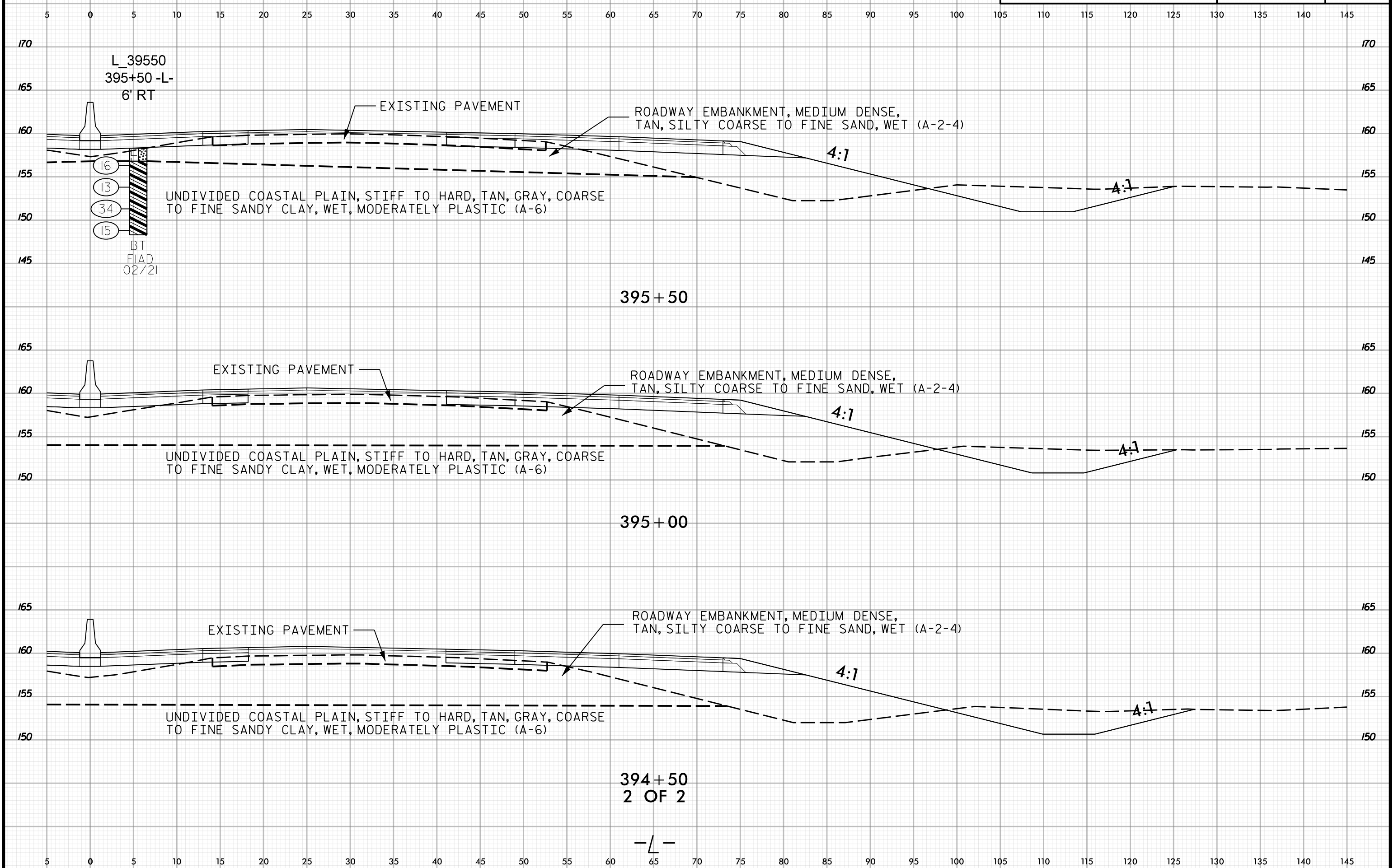
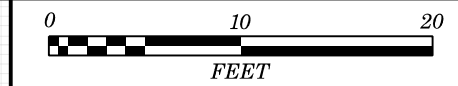



140 135 130 125 120 115 110 105 100 95 90 85 80 75 70 65 60 55 50 45 40 35 30 25 20 15 10 5 0 5

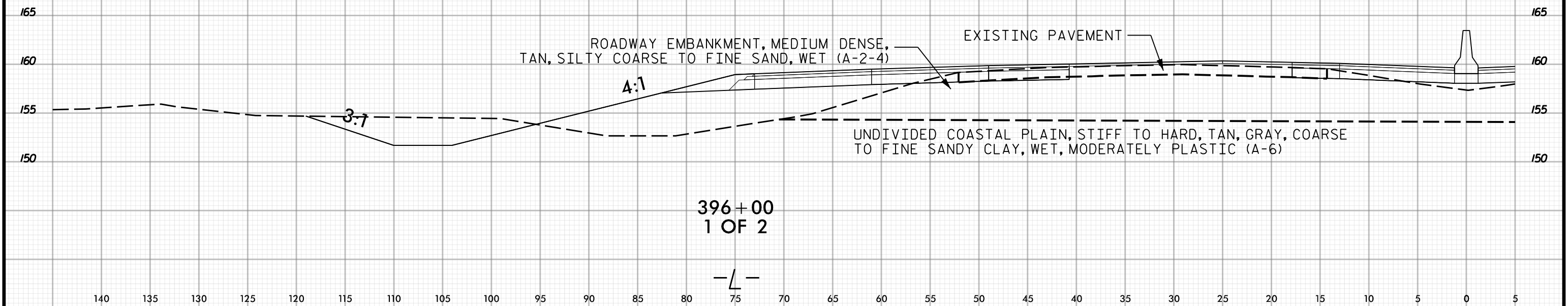
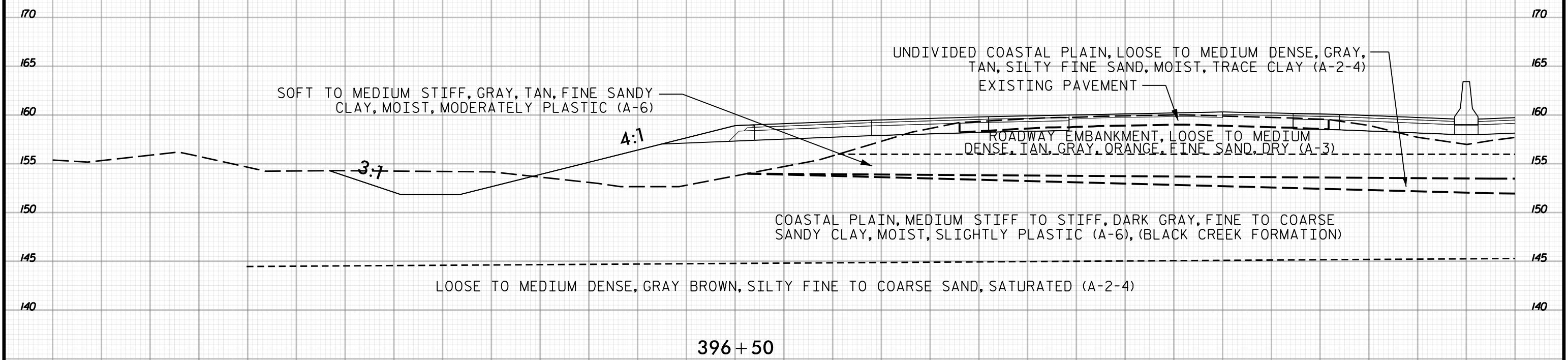

140 135 130 125 120 115 110 105 100 95 90 85 80 75 70 65 60 55 50 45 40 35 30 25 20 15 10 5 0 5

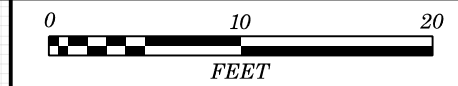

5 0 5 10 15 20 25 30 35 40 45 50 55 60 65 70 75 80 85 90 95 100 105 110 115 120 125 130 135 140 145

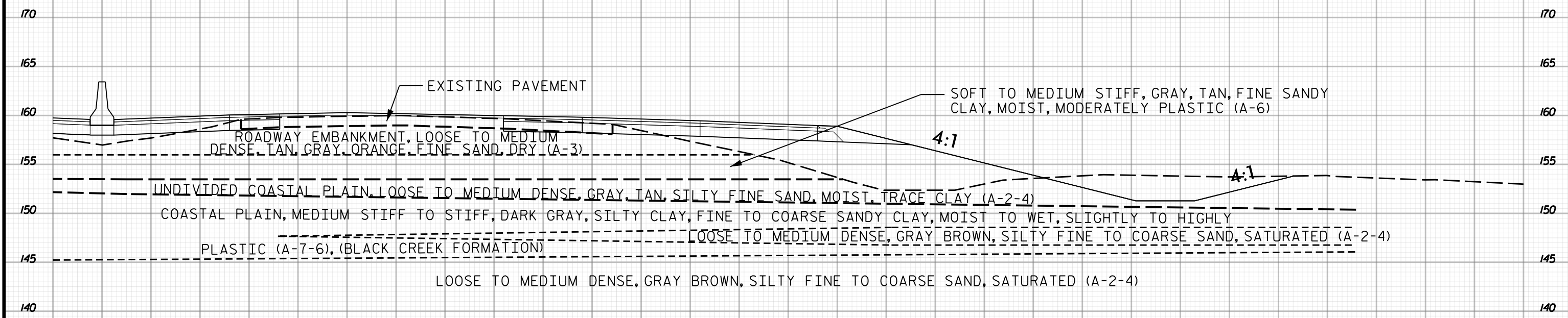

396+50

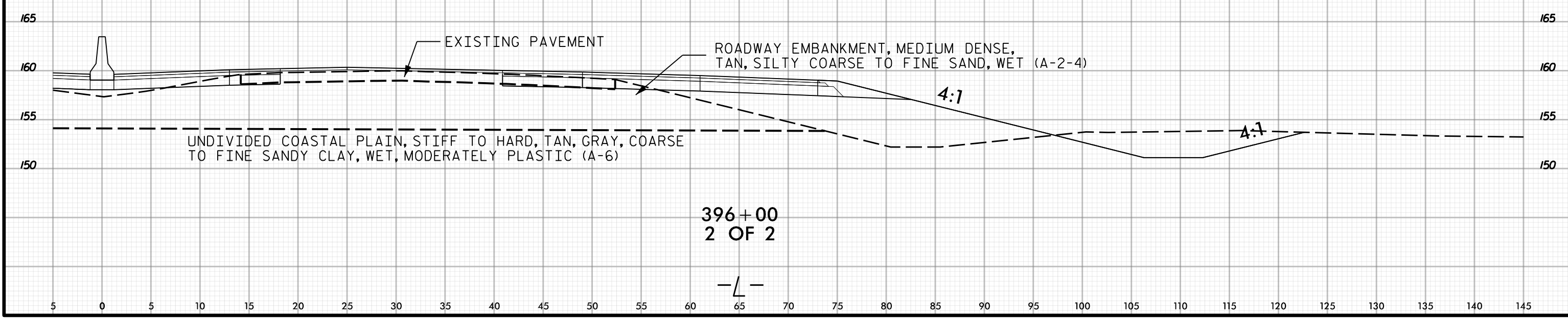

396+00
2 OF 2

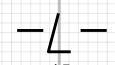

5 0 5 10 15 20 25 30 35 40 45 50 55 60 65 70 75 80 85 90 95 100 105 110 115 120 125 130 135 140 145



140 135 130 125 120 115 110 105 100 95 90 85 80 75 70 65 60 55 50 45 40 35 30 25 20 15 10 5 0 5

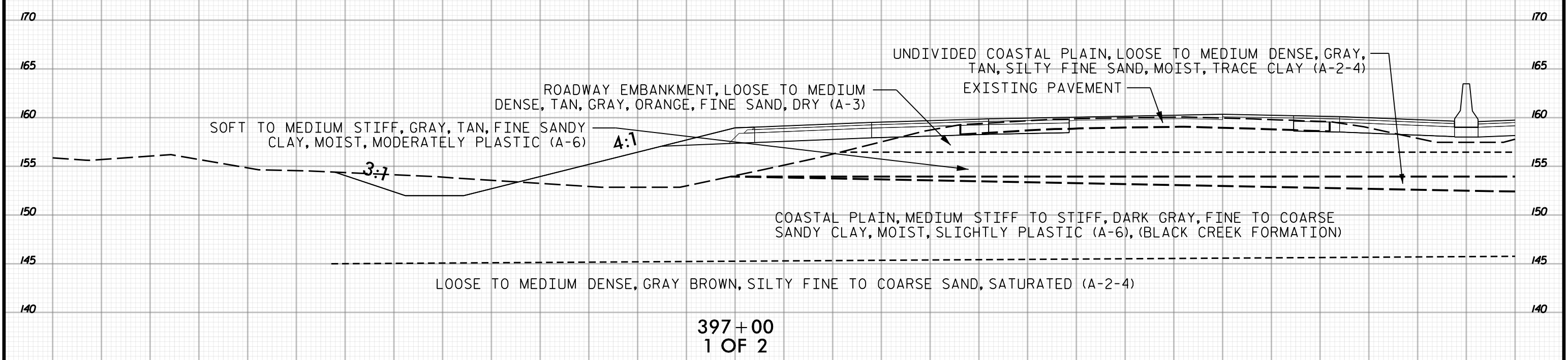
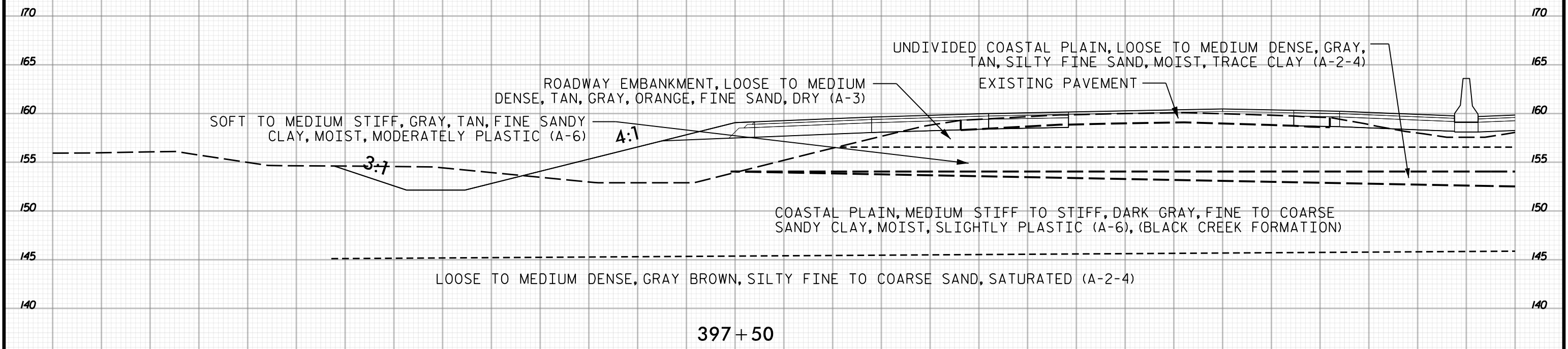

140 135 130 125 120 115 110 105 100 95 90 85 80 75 70 65 60 55 50 45 40 35 30 25 20 15 10 5 0 5

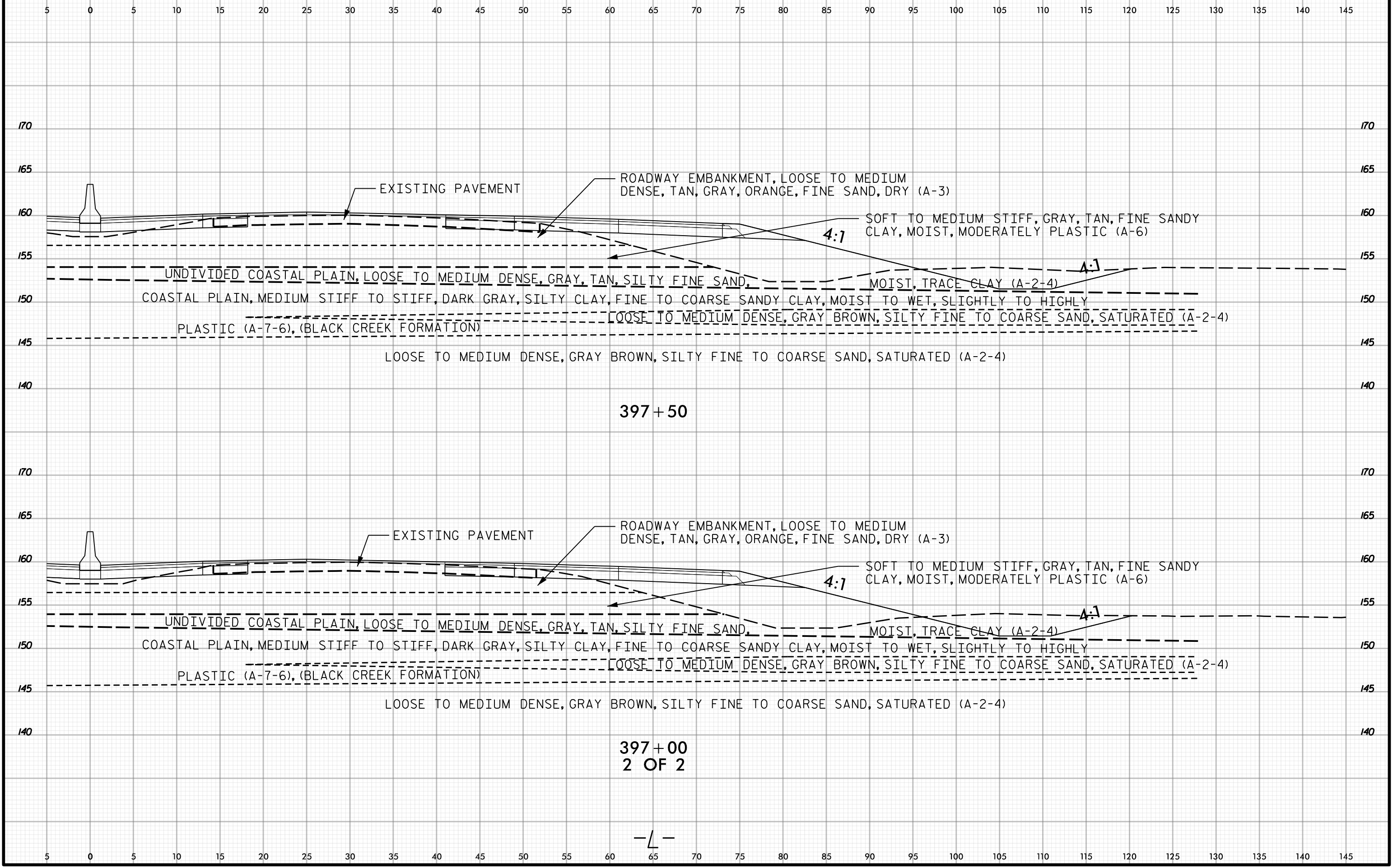

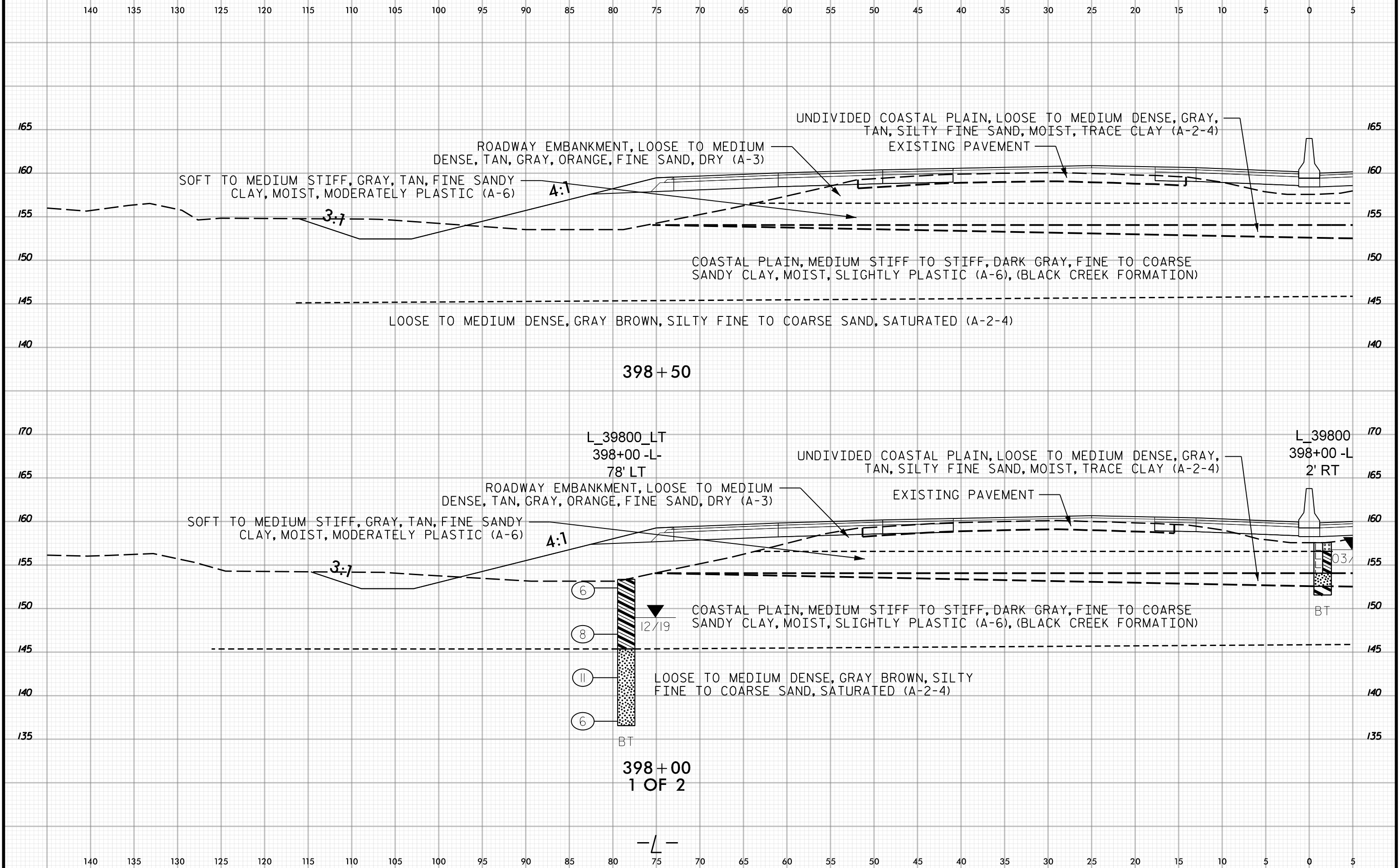

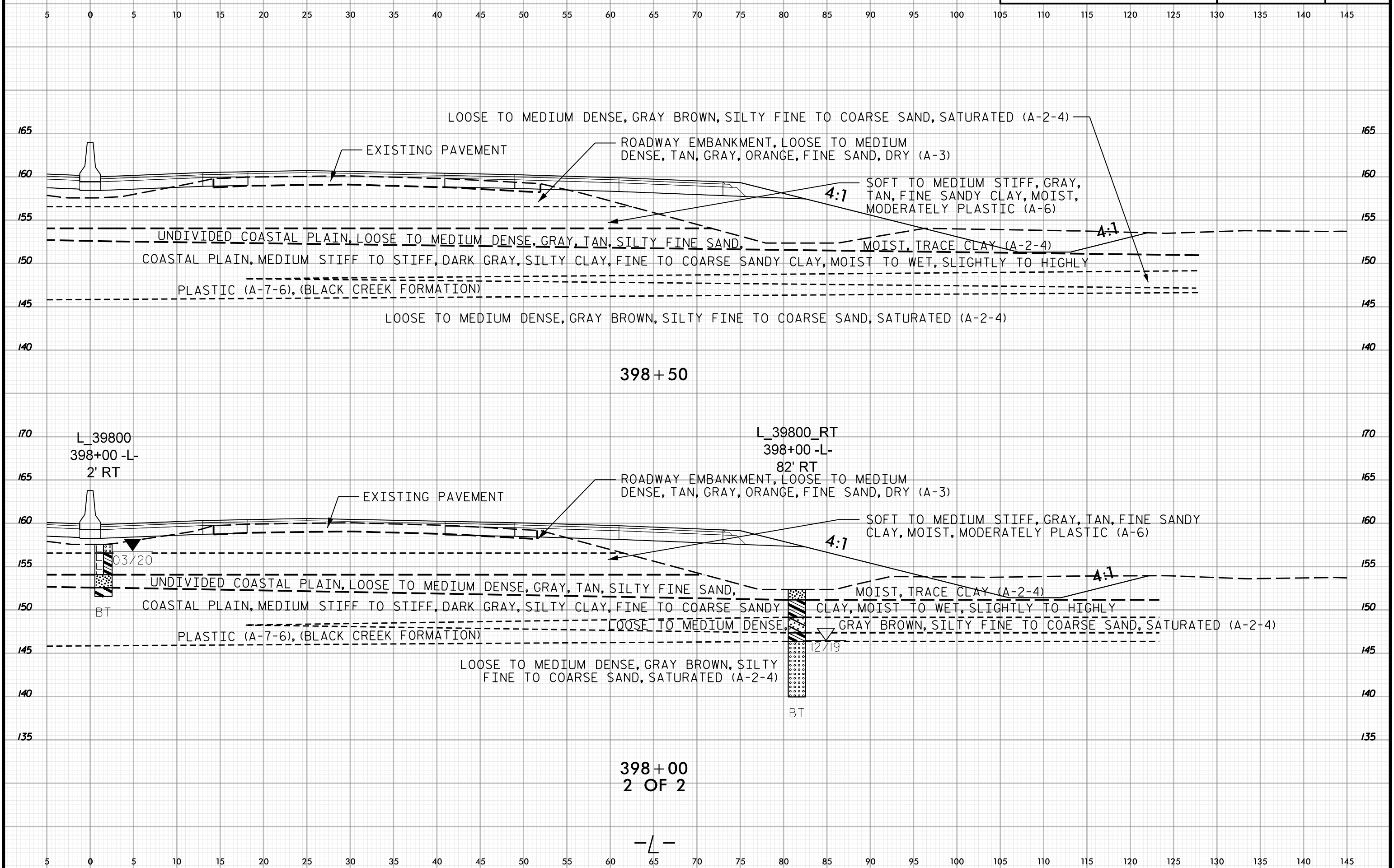

398 + 50

L_39800
398+00 -L-
2' RT

L_39800_RT
398+00 -L-
82' RT

398 + 00
2 OF 2

-L-

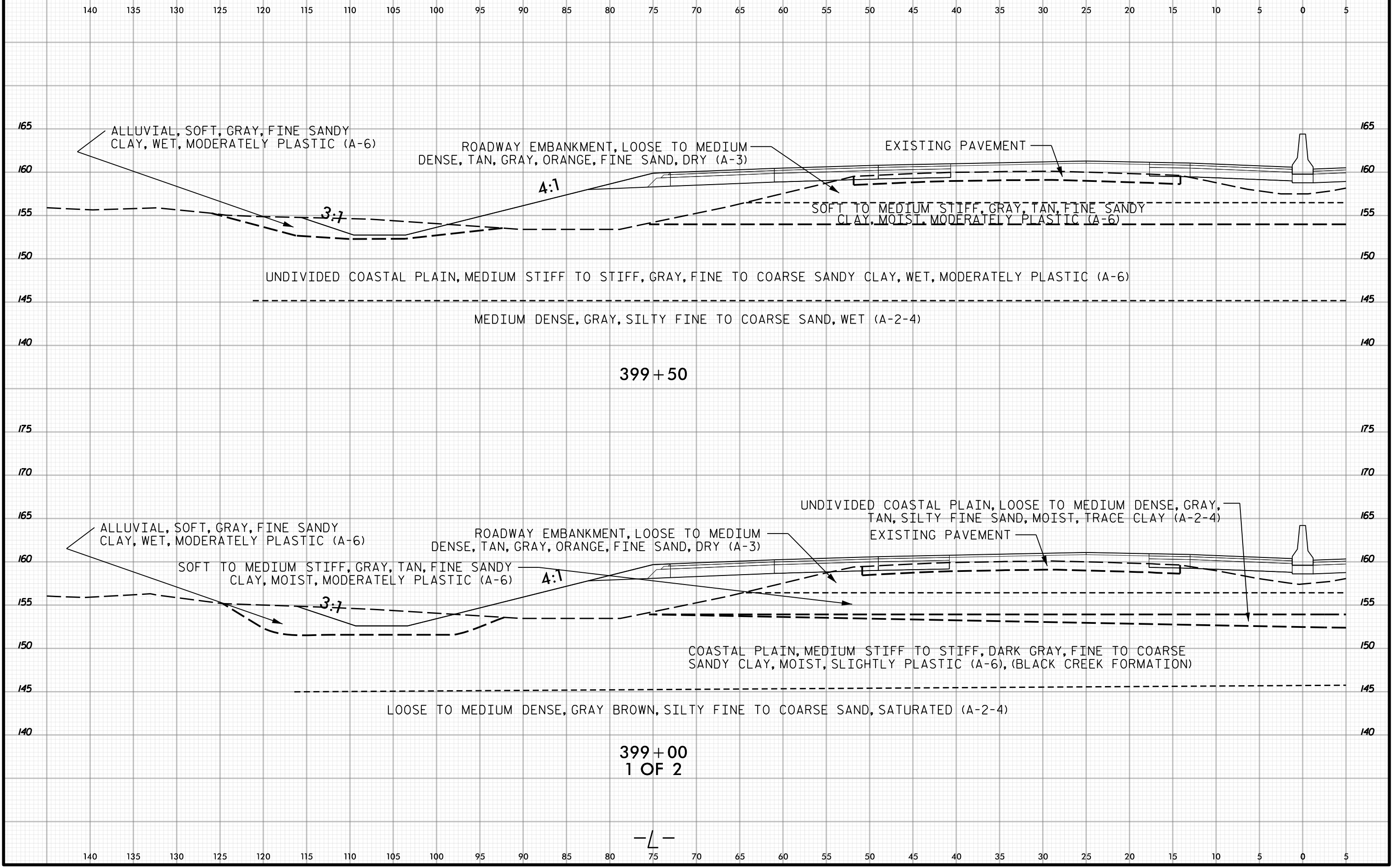
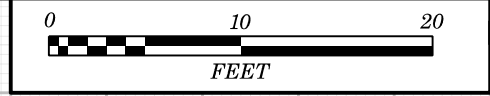

399+00
1 OF 2

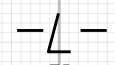

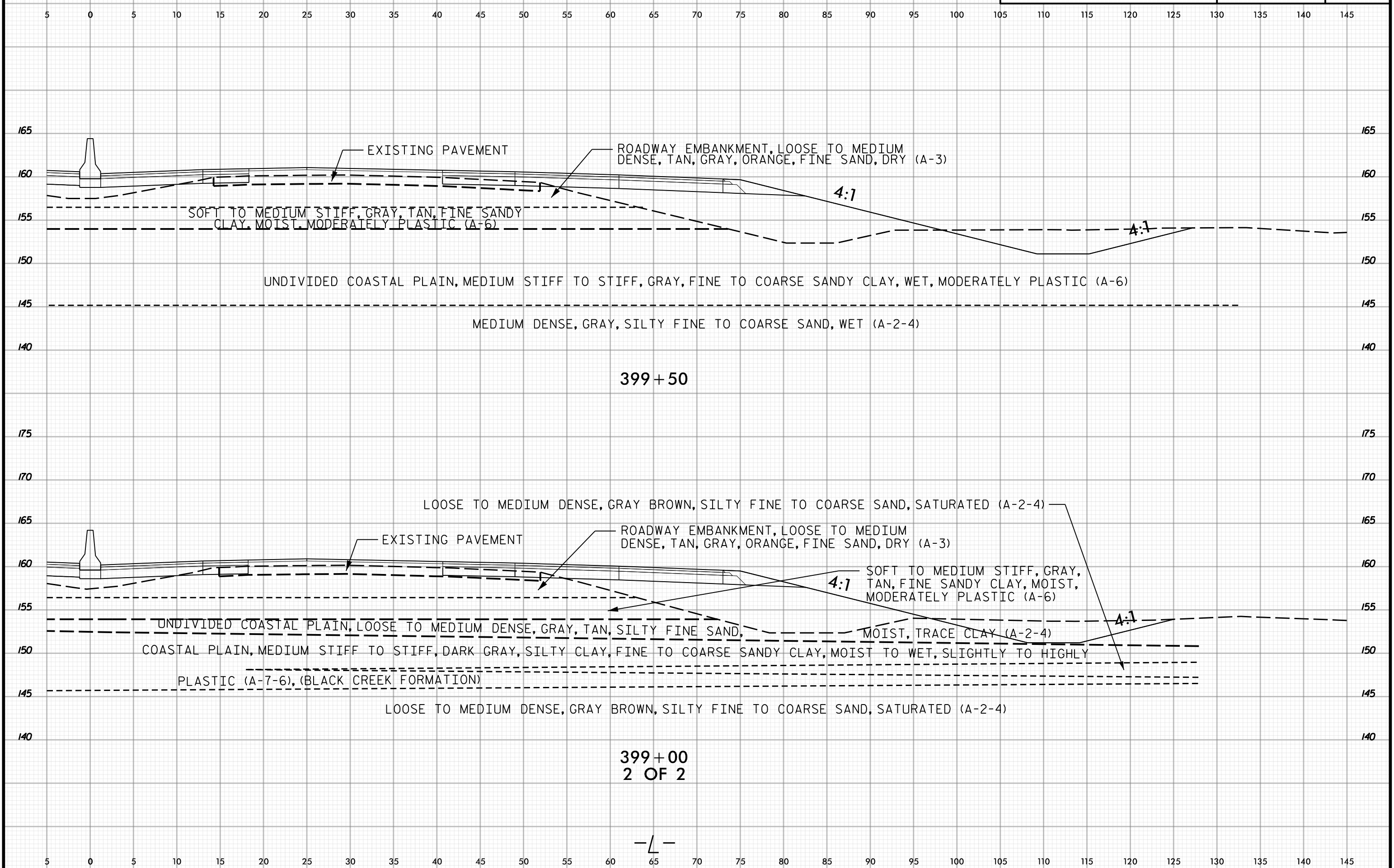
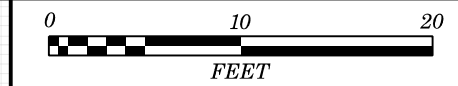

399+00
2 OF 2

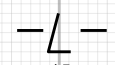



140 135 130 125 120 115 110 105 100 95 90 85 80 75 70 65 60 55 50 45 40 35 30 25 20 15 10 5 0 5

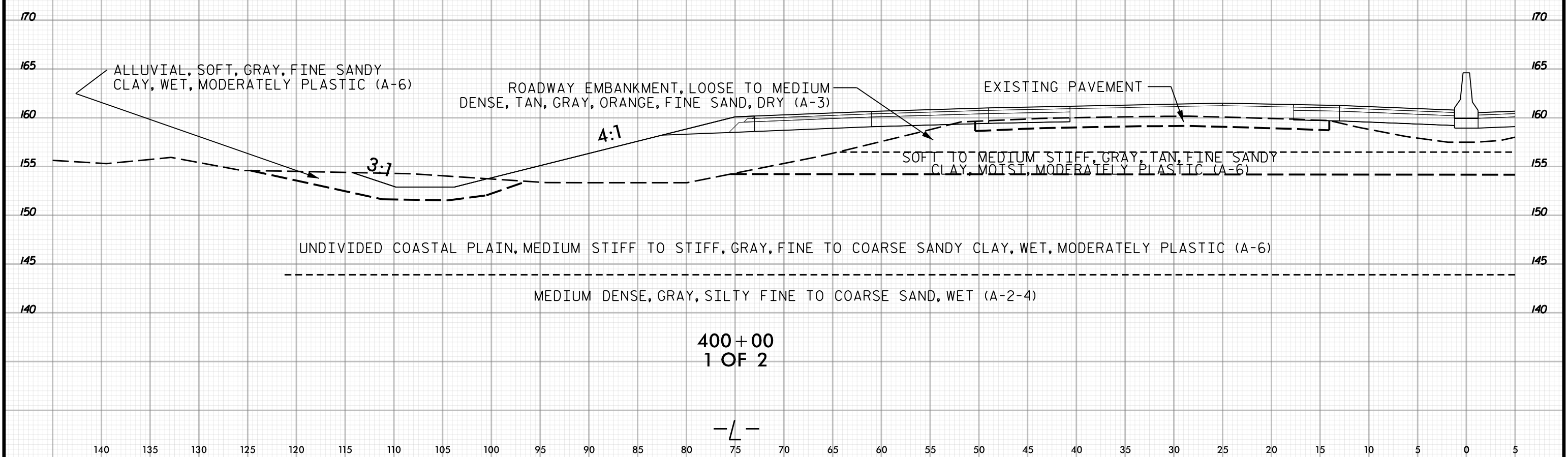
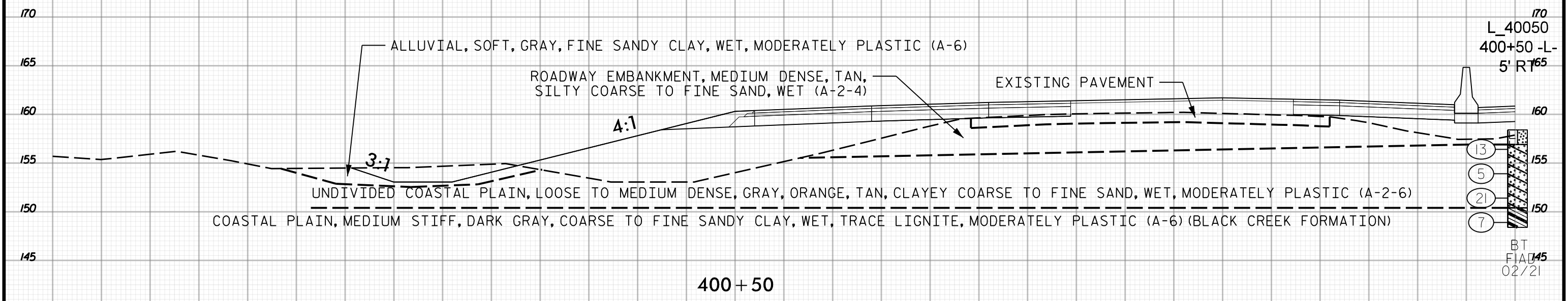

140 135 130 125 120 115 110 105 100 95 90 85 80 75 70 65 60 55 50 45 40 35 30 25 20 15 10 5 0 5



5 0 5 10 15 20 25 30 35 40 45 50 55 60 65 70 75 80 85 90 95 100 105 110 115 120 125 130 135 140 145

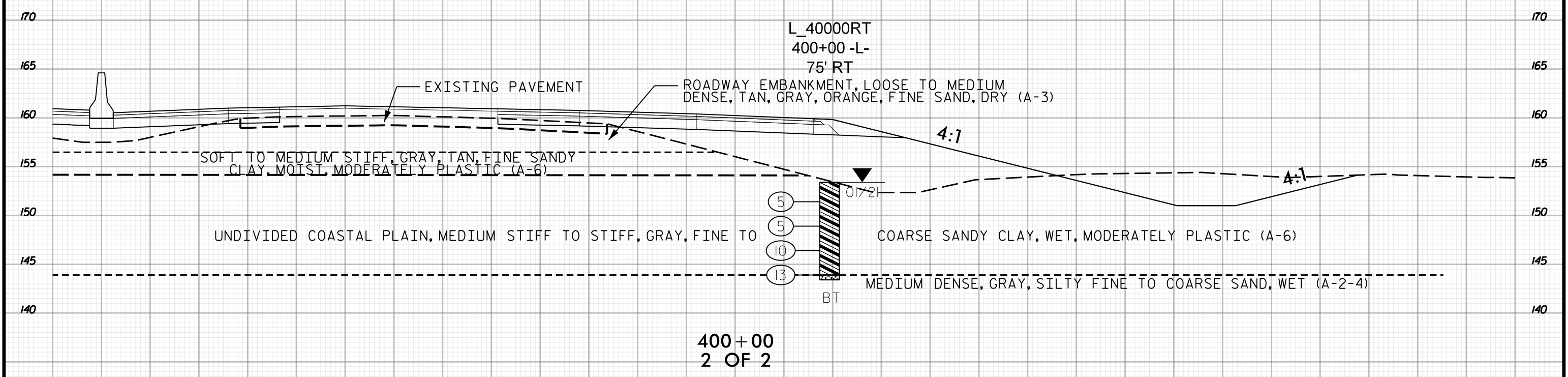
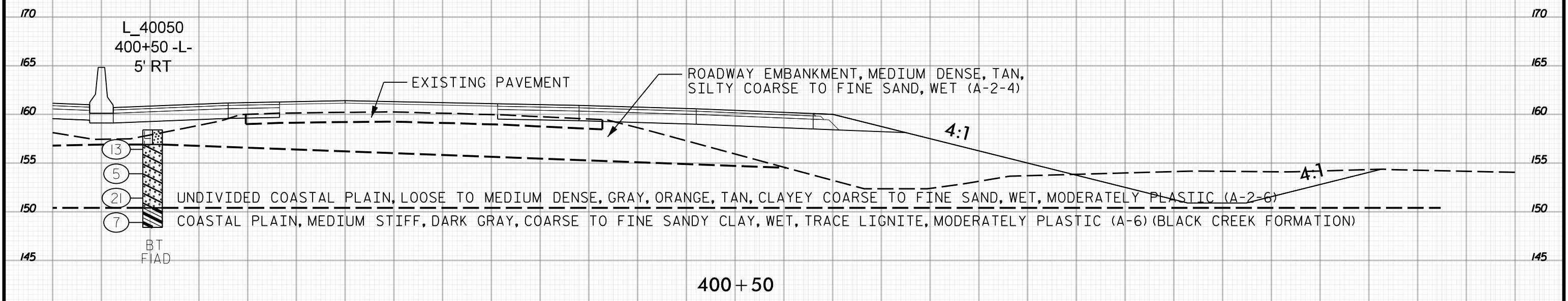

5 0 5 10 15 20 25 30 35 40 45 50 55 60 65 70 75 80 85 90 95 100 105 110 115 120 125 130 135 140 145



140 135 130 125 120 115 110 105 100 95 90 85 80 75 70 65 60 55 50 45 40 35 30 25 20 15 10 5 0 5

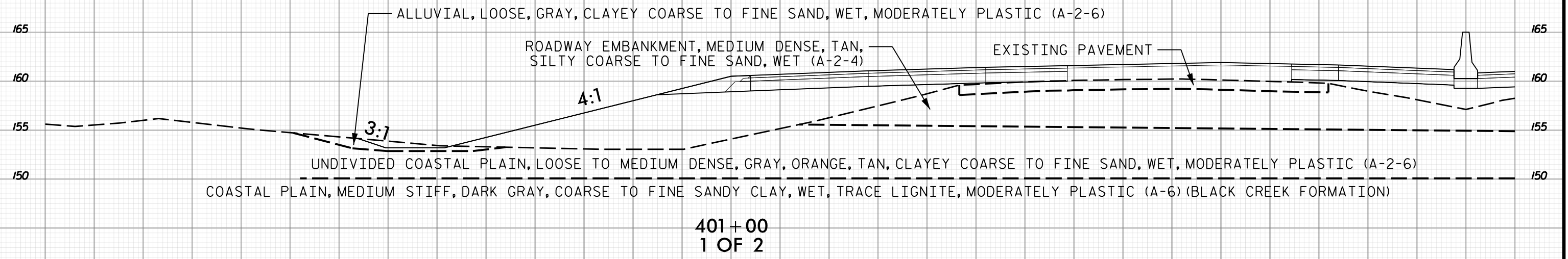
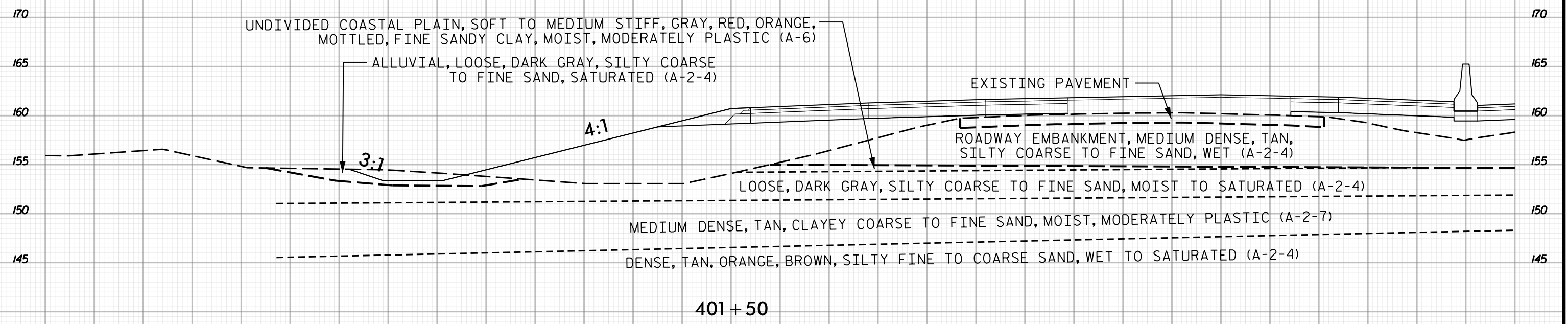

140 135 130 125 120 115 110 105 100 95 90 85 80 75 70 65 60 55 50 45 40 35 30 25 20 15 10 5 0 5

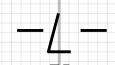



5 0 5 10 15 20 25 30 35 40 45 50 55 60 65 70 75 80 85 90 95 100 105 110 115 120 125 130 135 140 145

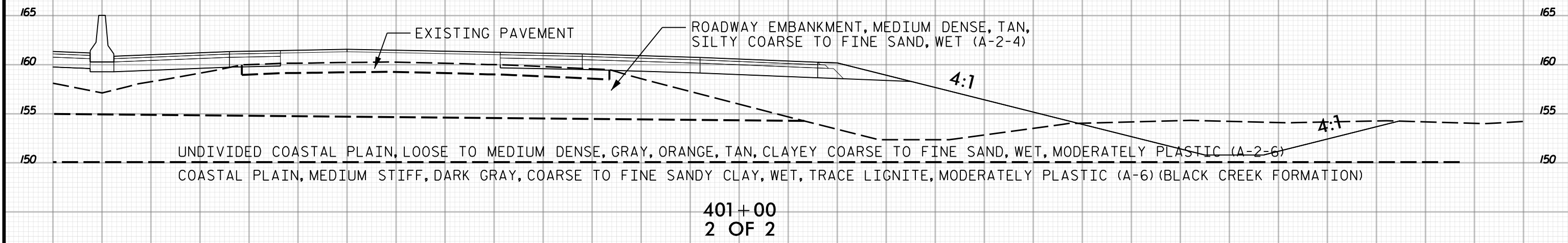
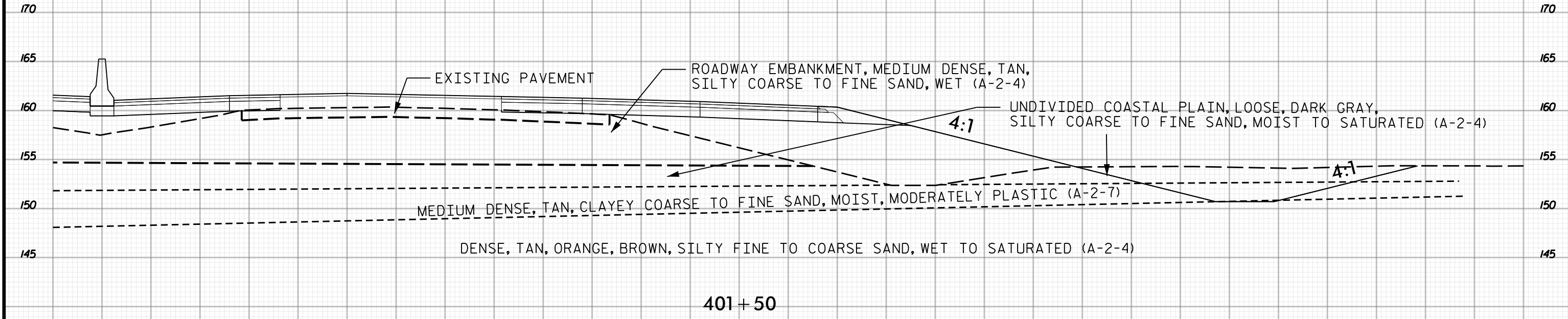

5 0 5 10 15 20 25 30 35 40 45 50 55 60 65 70 75 80 85 90 95 100 105 110 115 120 125 130 135 140 145

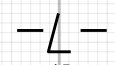

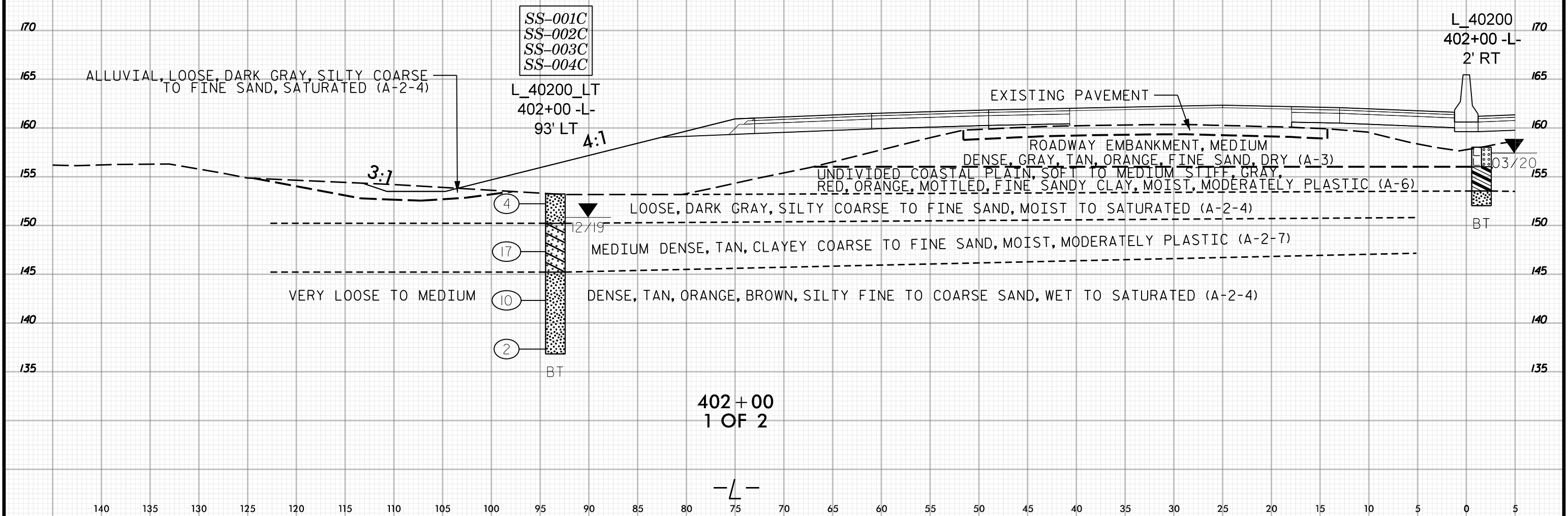
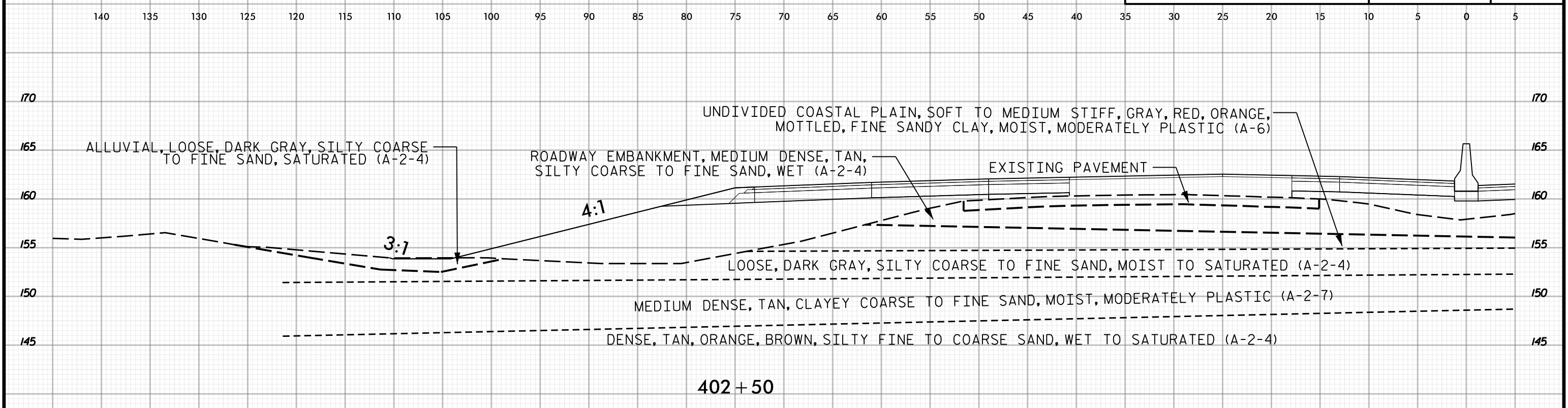

402 + 00
1 OF 2

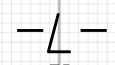

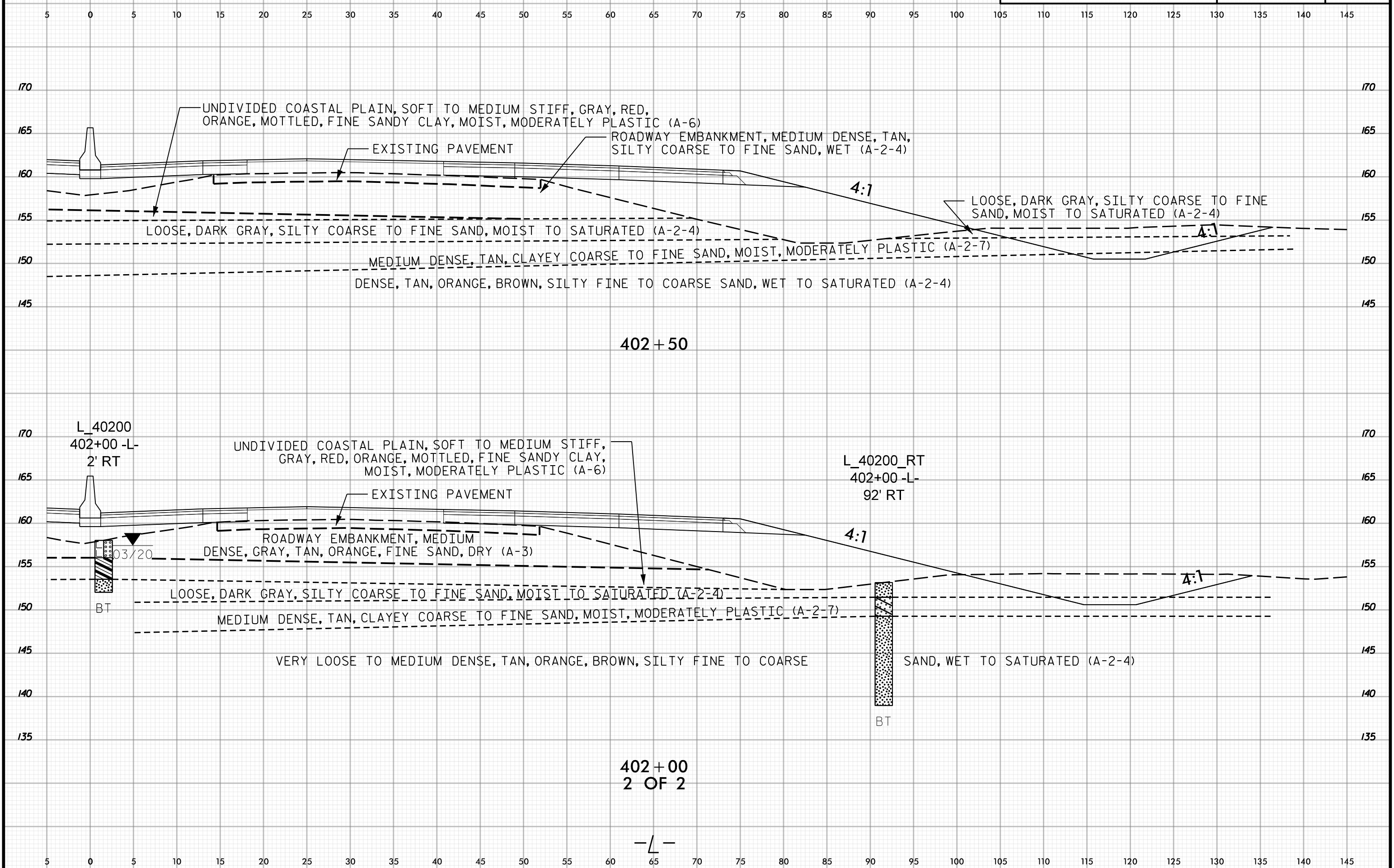

402 + 50

402 + 00
2 OF 2

-L-

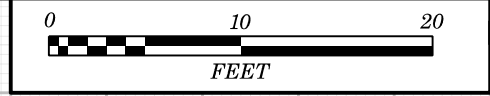

140 135 130 125 120 115 110 105 100 95 90 85 80 75 70 65 60 55 50 45 40 35 30 25 20 15 10 5 0 5

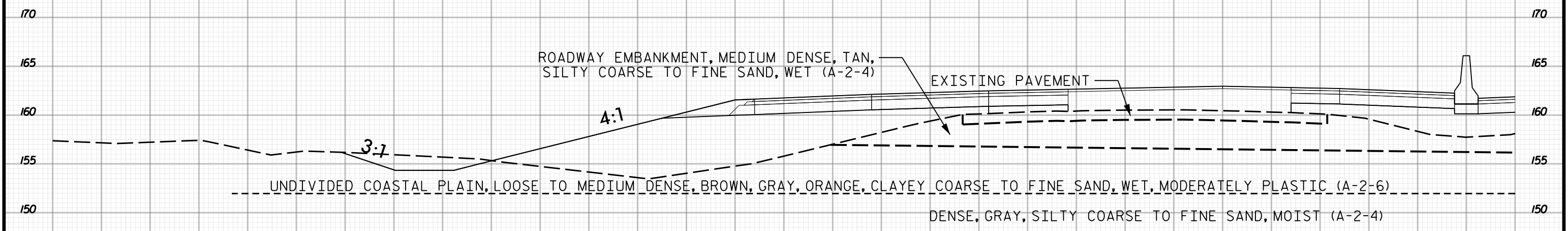

403 + 50

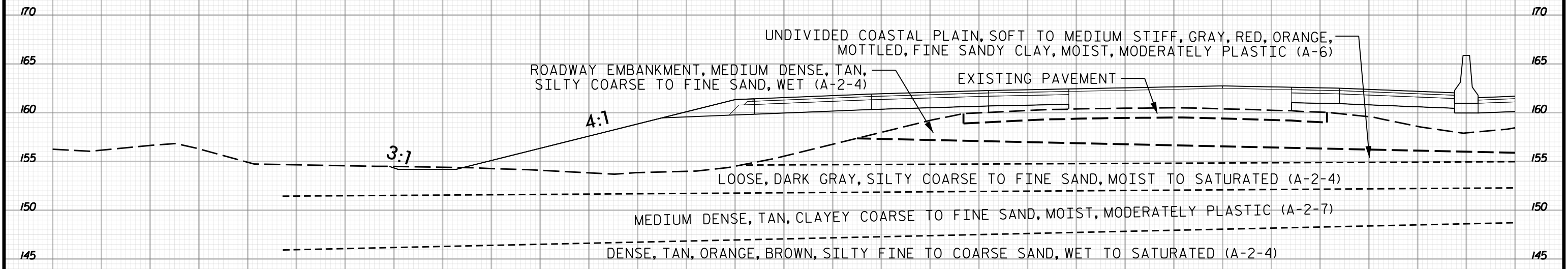

403 + 00
1 OF 2

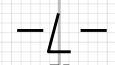

140 135 130 125 120 115 110 105 100 95 90 85 80 75 70 65 60 55 50 45 40 35 30 25 20 15 10 5 0 5

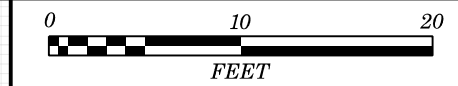

5 0 5 10 15 20 25 30 35 40 45 50 55 60 65 70 75 80 85 90 95 100 105 110 115 120 125 130 135 140 145

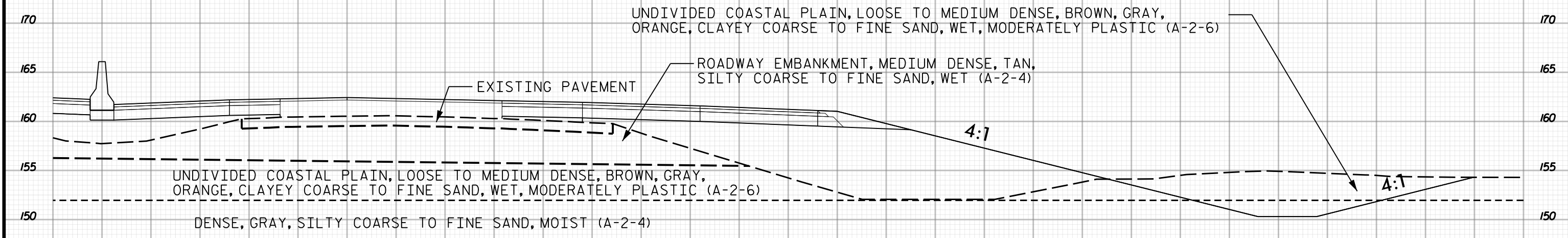

403+50

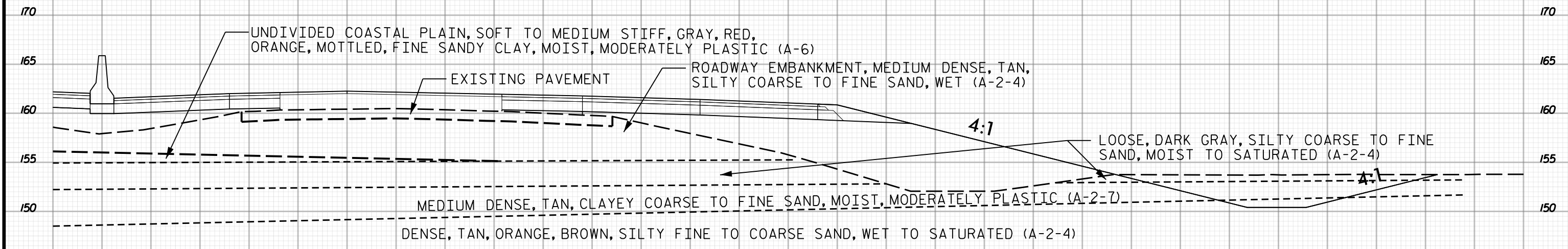

403+00
2 OF 2

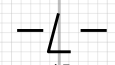

5 0 5 10 15 20 25 30 35 40 45 50 55 60 65 70 75 80 85 90 95 100 105 110 115 120 125 130 135 140 145



140 135 130 125 120 115 110 105 100 95 90 85 80 75 70 65 60 55 50 45 40 35 30 25 20 15 10 5 0 5

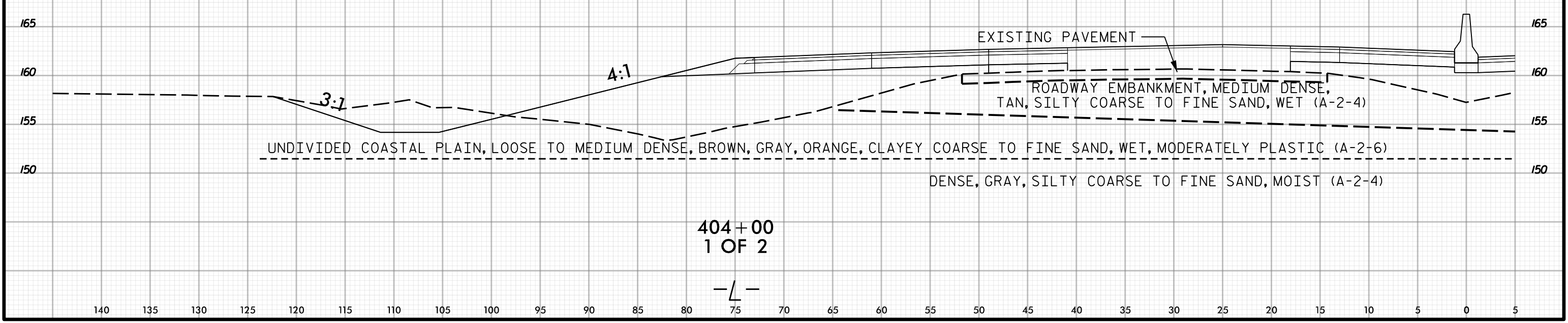
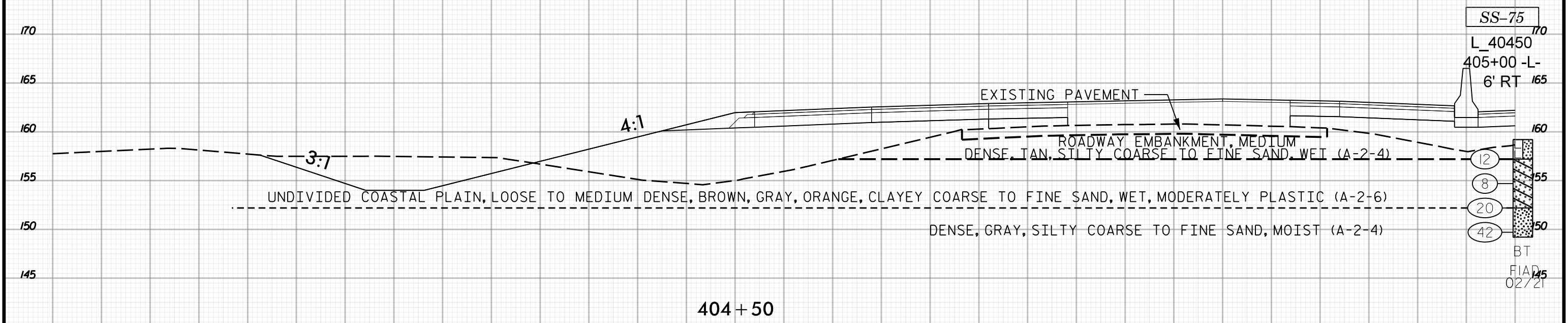

140 135 130 125 120 115 110 105 100 95 90 85 80 75 70 65 60 55 50 45 40 35 30 25 20 15 10 5 0 5

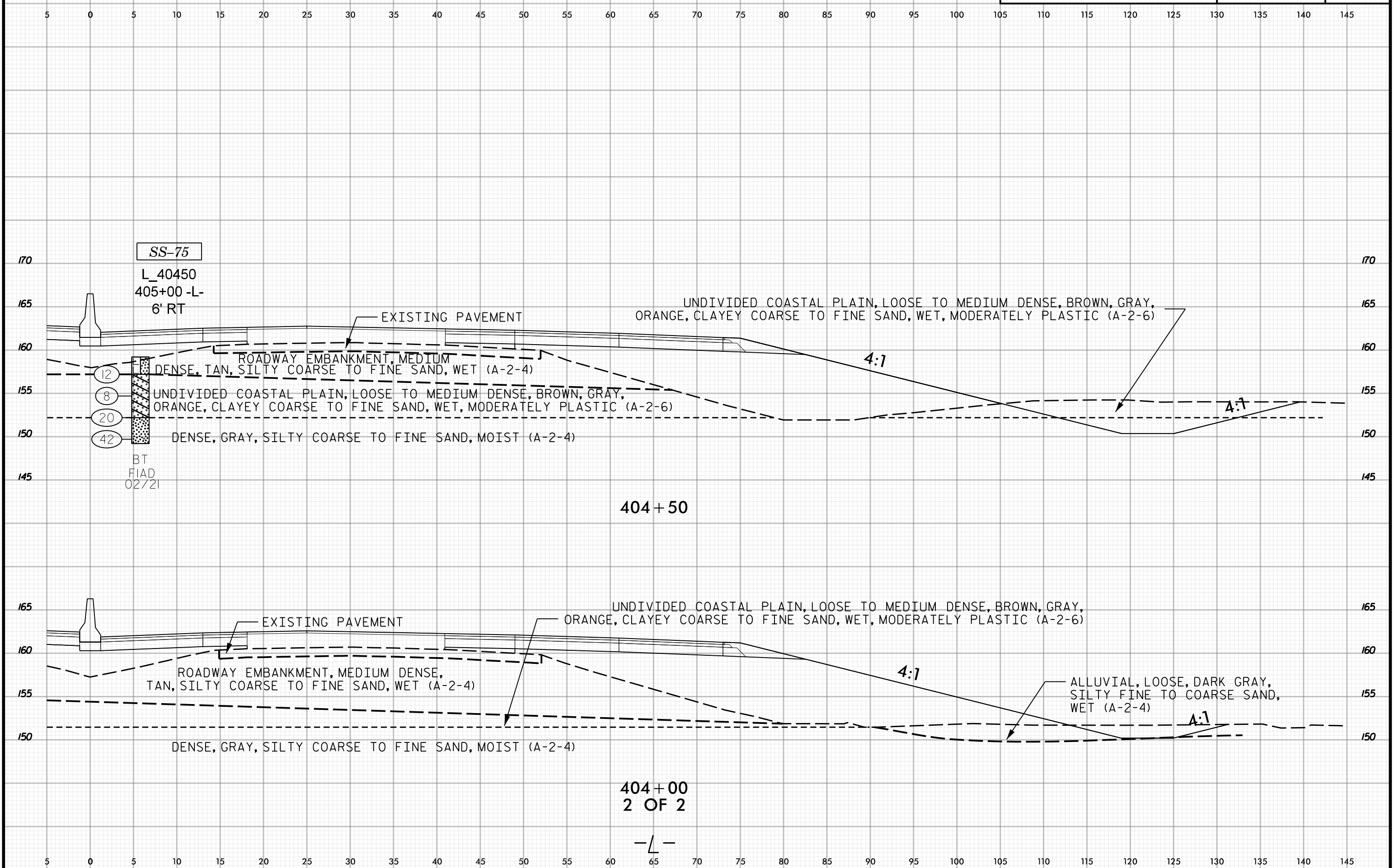



140 135 130 125 120 115 110 105 100 95 90 85 80 75 70 65 60 55 50 45 40 35 30 25 20 15 10 5 0 5

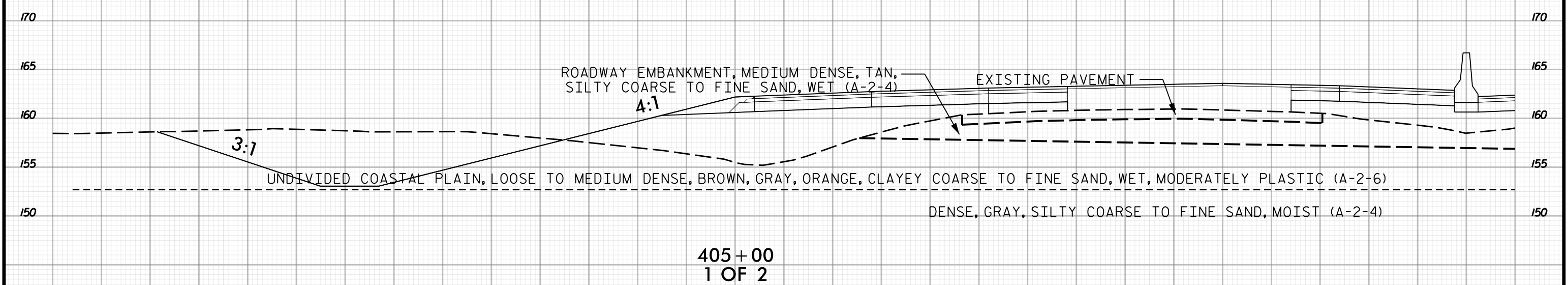
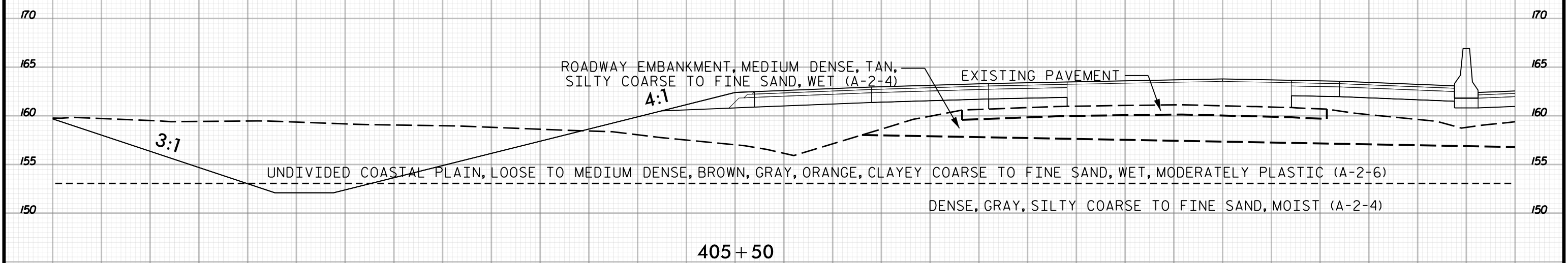

140 135 130 125 120 115 110 105 100 95 90 85 80 75 70 65 60 55 50 45 40 35 30 25 20 15 10 5 0 5



5 0 5 10 15 20 25 30 35 40 45 50 55 60 65 70 75 80 85 90 95 100 105 110 115 120 125 130 135 140 145

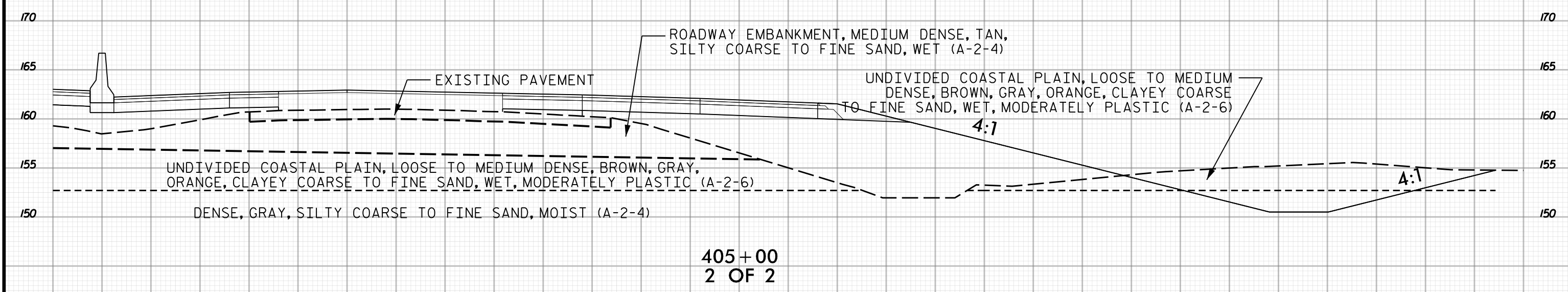
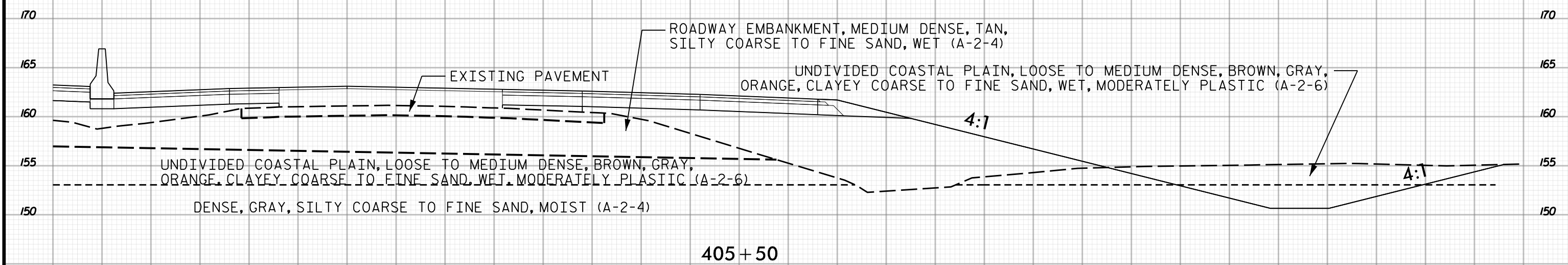

5 0 5 10 15 20 25 30 35 40 45 50 55 60 65 70 75 80 85 90 95 100 105 110 115 120 125 130 135 140 145

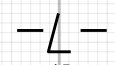

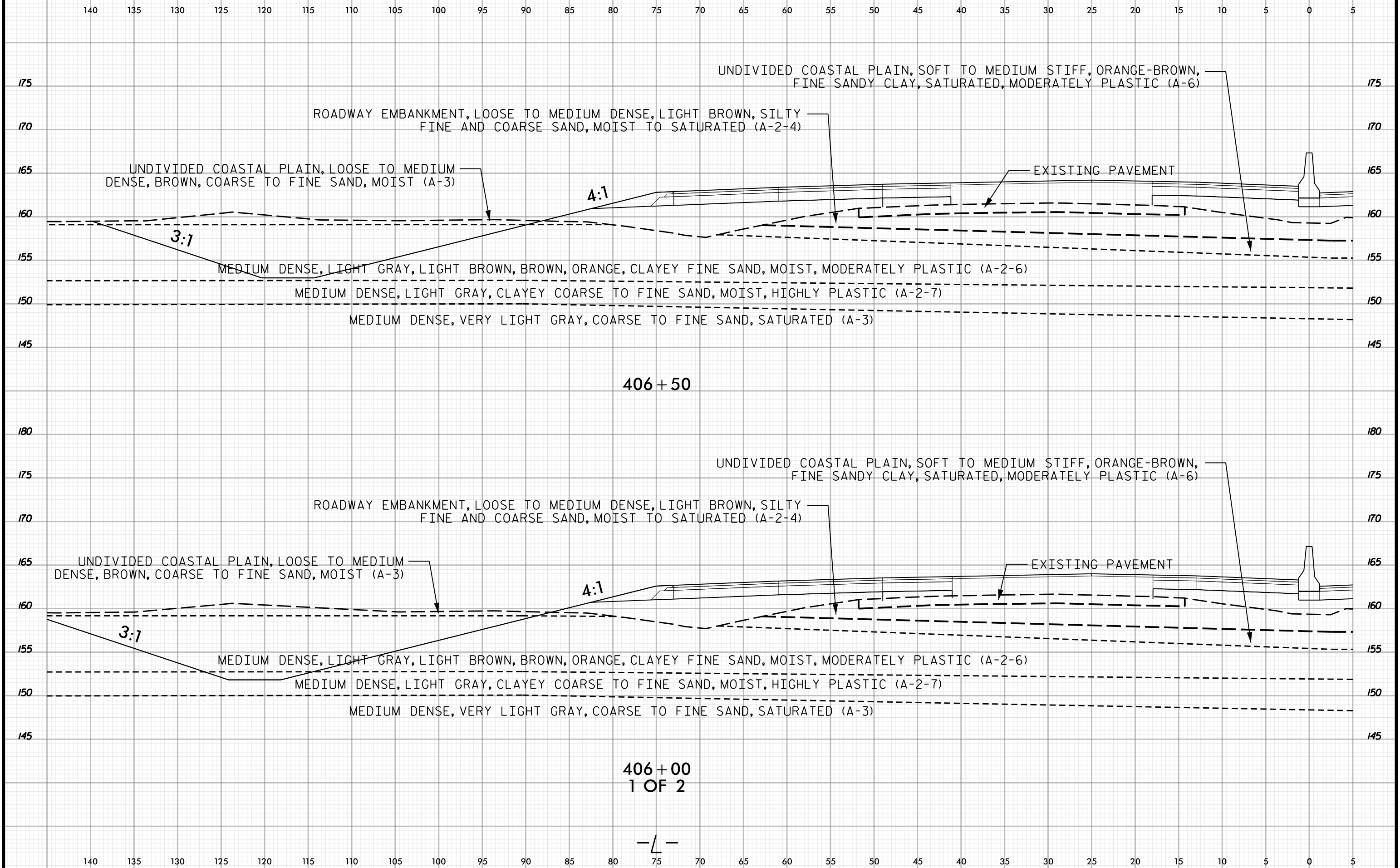
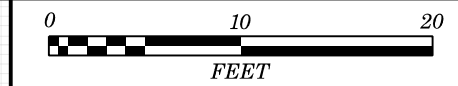

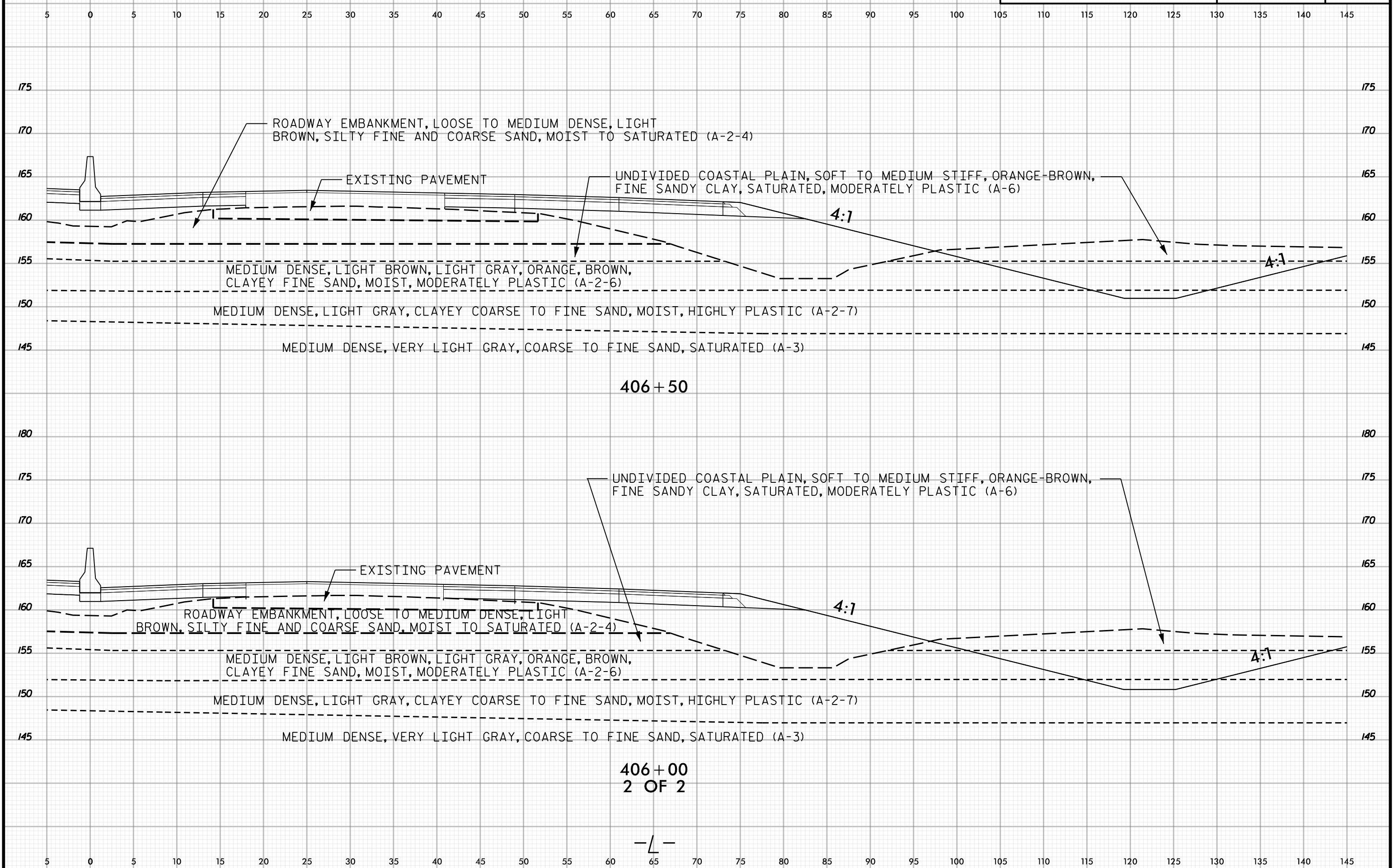

406+50

406+00
2 OF 2

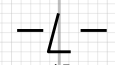

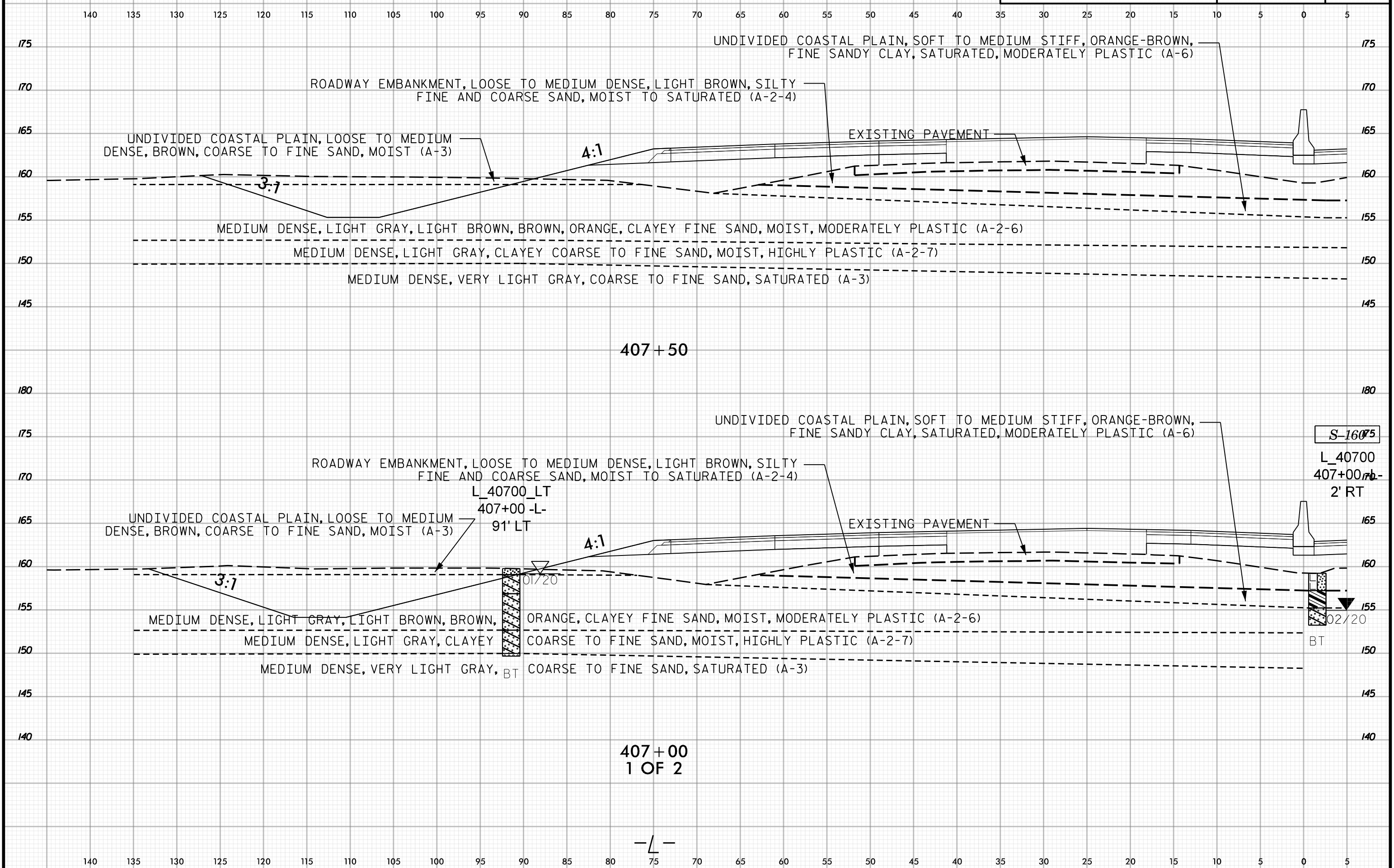

407 + 50

407 + 00
1 OF 2

S-16075
L_40700
407+00 -L-
2' RT
BT

L_40700_LT
407+00 -L-
91' LT

-L-

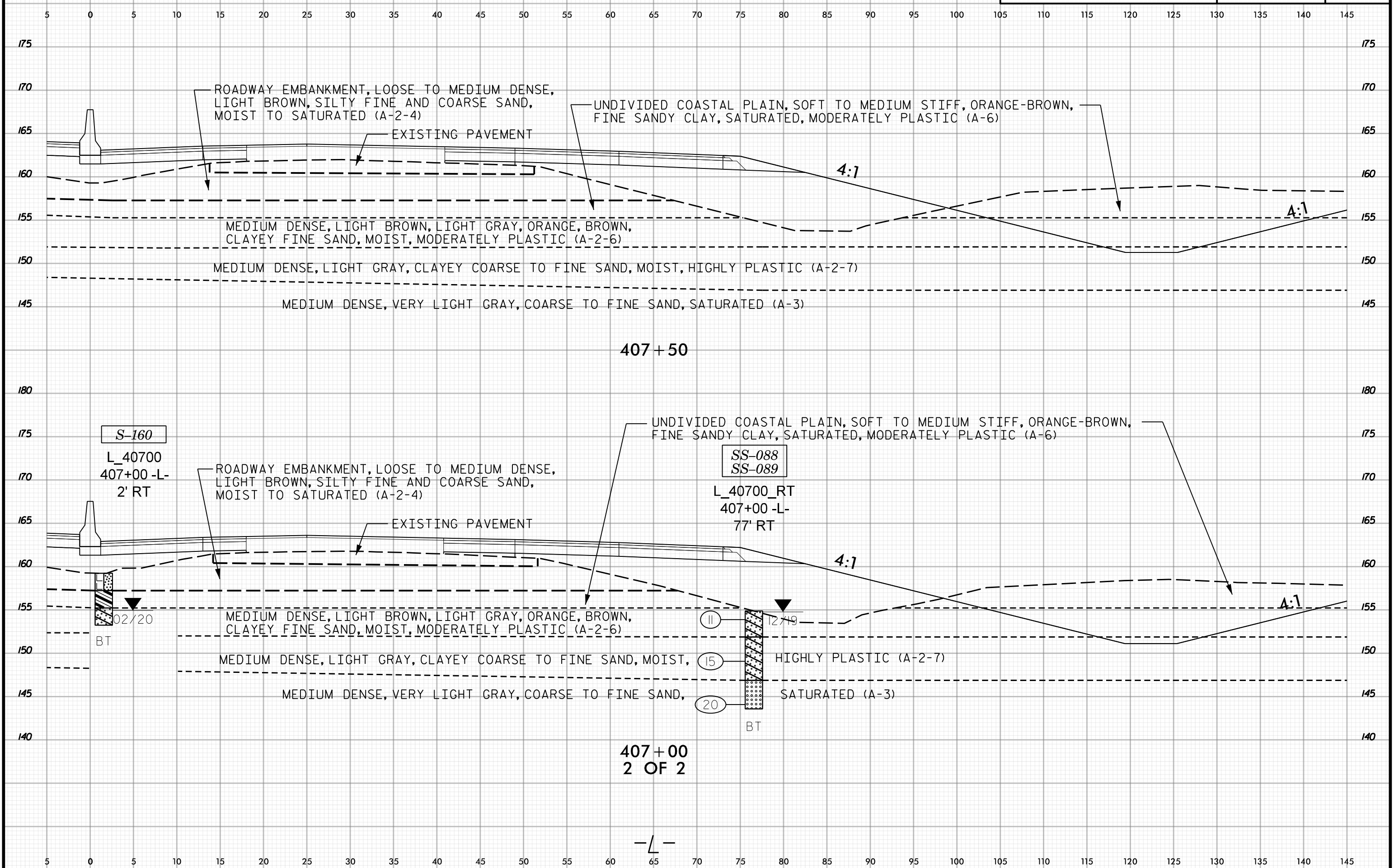
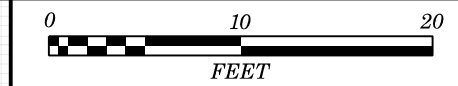



140 135 130 125 120 115 110 105 100 95 90 85 80 75 70 65 60 55 50 45 40 35 30 25 20 15 10 5 0 5

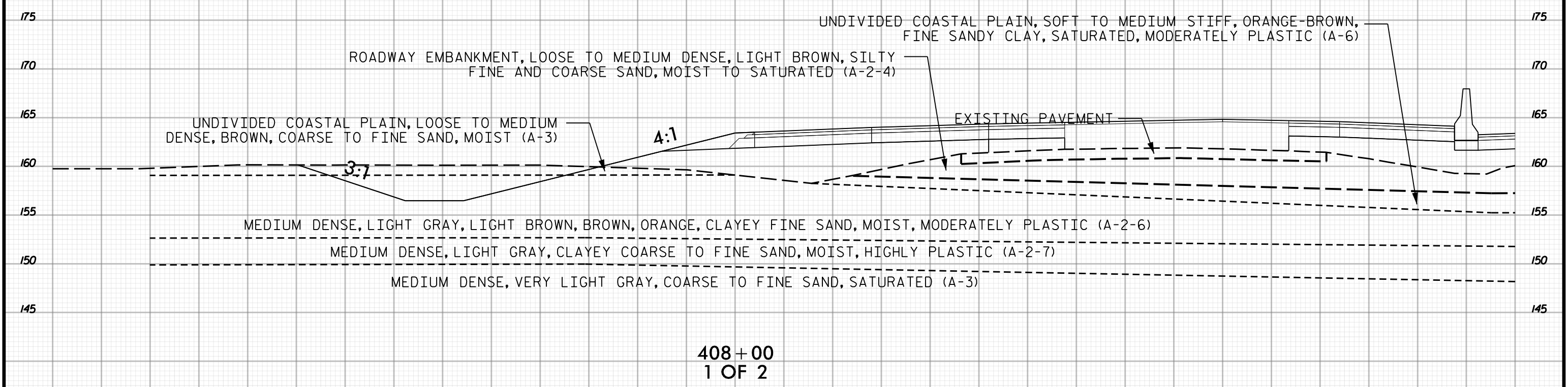
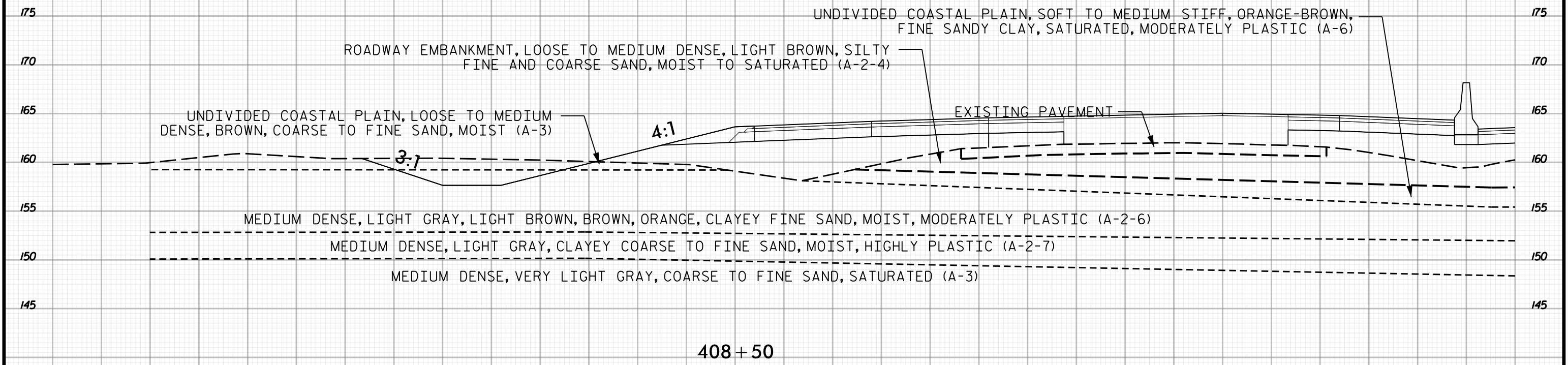

140 135 130 125 120 115 110 105 100 95 90 85 80 75 70 65 60 55 50 45 40 35 30 25 20 15 10 5 0 5

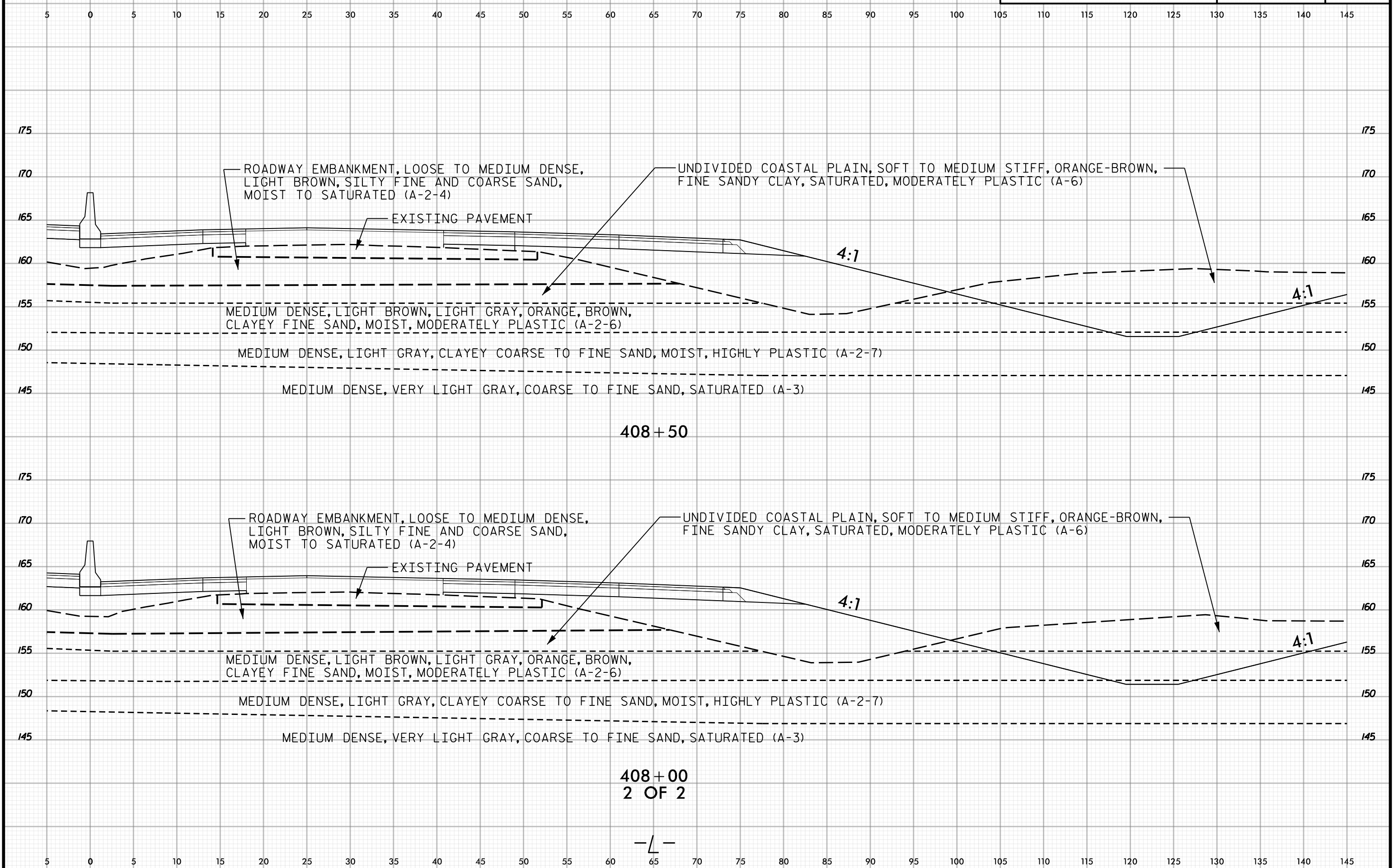



140 135 130 125 120 115 110 105 100 95 90 85 80 75 70 65 60 55 50 45 40 35 30 25 20 15 10 5 0 5

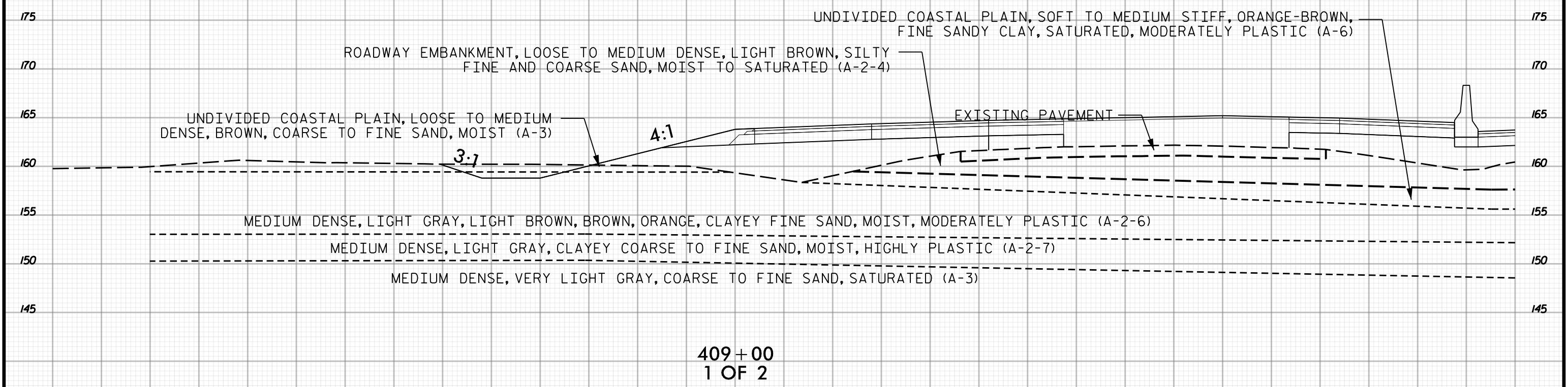
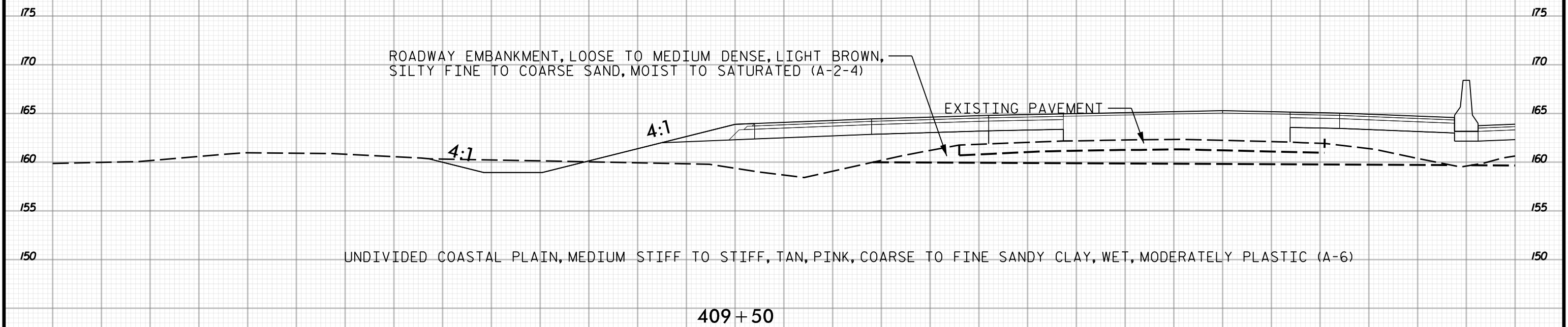

140 135 130 125 120 115 110 105 100 95 90 85 80 75 70 65 60 55 50 45 40 35 30 25 20 15 10 5 0 5

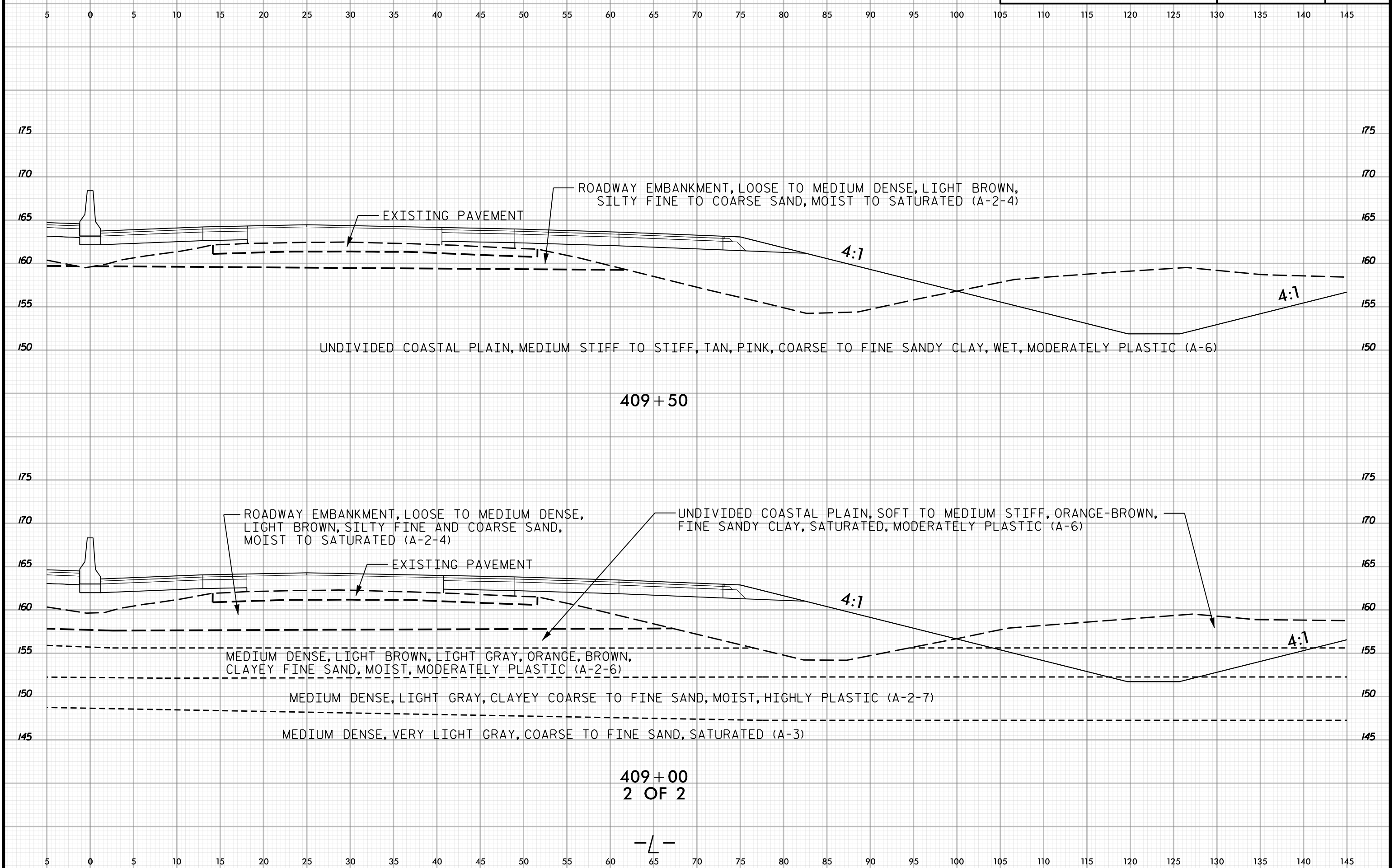

ROADWAY EMBANKMENT, LOOSE TO MEDIUM DENSE, LIGHT BROWN, SILTY FINE TO COARSE SAND, MOIST TO SATURATED (A-2-4)

EXISTING PAVEMENT

UNDIVIDED COASTAL PLAIN, MEDIUM STIFF TO STIFF, TAN, PINK, COARSE TO FINE SANDY CLAY, WET, MODERATELY PLASTIC (A-6)

409+50

ROADWAY EMBANKMENT, LOOSE TO MEDIUM DENSE, LIGHT BROWN, SILTY FINE AND COARSE SAND, MOIST TO SATURATED (A-2-4)

EXISTING PAVEMENT

UNDIVIDED COASTAL PLAIN, SOFT TO MEDIUM STIFF, ORANGE-BROWN, FINE SANDY CLAY, SATURATED, MODERATELY PLASTIC (A-6)

MEDIUM DENSE, LIGHT BROWN, LIGHT GRAY, ORANGE, BROWN, CLAYEY FINE SAND, MOIST, MODERATELY PLASTIC (A-2-6)

MEDIUM DENSE, LIGHT GRAY, CLAYEY COARSE TO FINE SAND, MOIST, HIGHLY PLASTIC (A-2-7)

MEDIUM DENSE, VERY LIGHT GRAY, COARSE TO FINE SAND, SATURATED (A-3)

409+00
2 OF 2

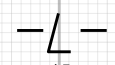



140 135 130 125 120 115 110 105 100 95 90 85 80 75 70 65 60 55 50 45 40 35 30 25 20 15 10 5 0 5

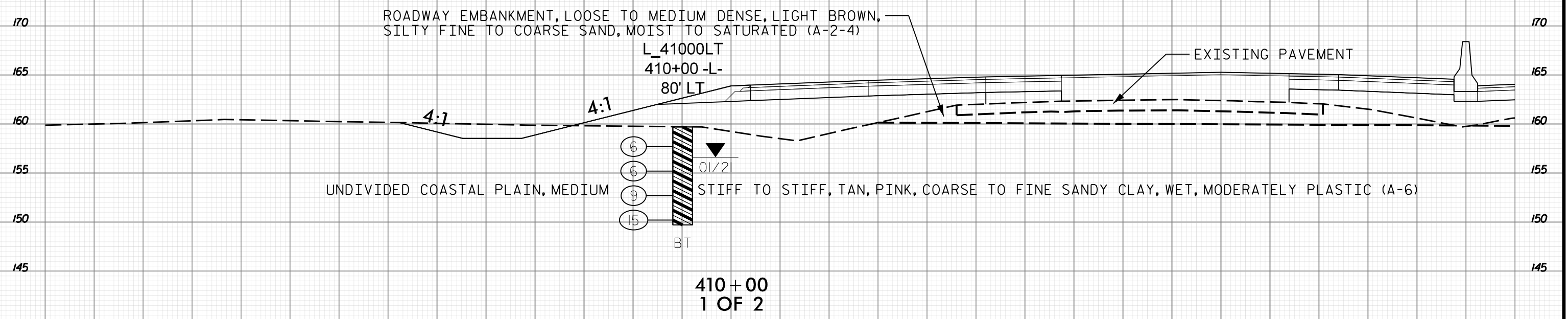
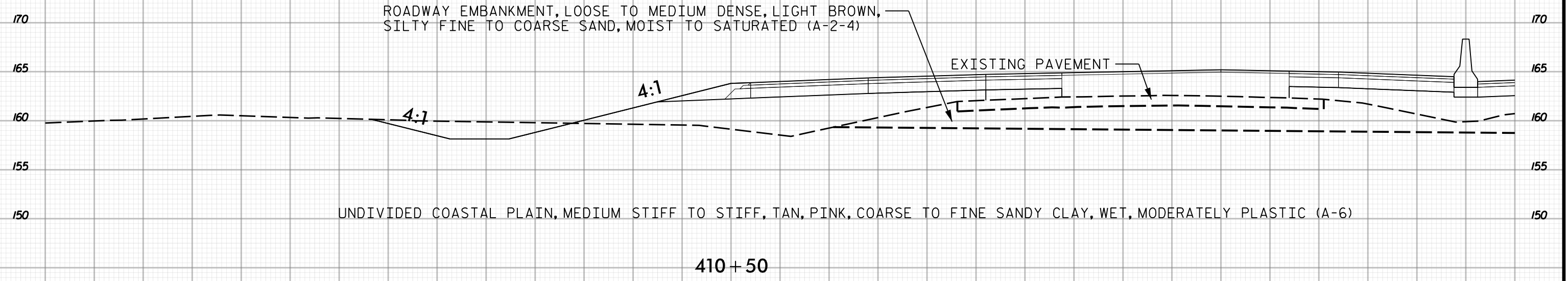

140 135 130 125 120 115 110 105 100 95 90 85 80 75 70 65 60 55 50 45 40 35 30 25 20 15 10 5 0 5

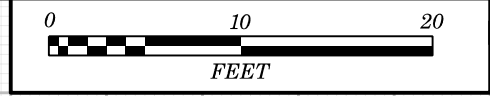

PROJ. REFERENCE NO.	SHEET NO.
I-5987A	739

5 0 5 10 15 20 25 30 35 40 45 50 55 60 65 70 75 80 85 90 95 100 105 110 115 120 125 130 135 140 145

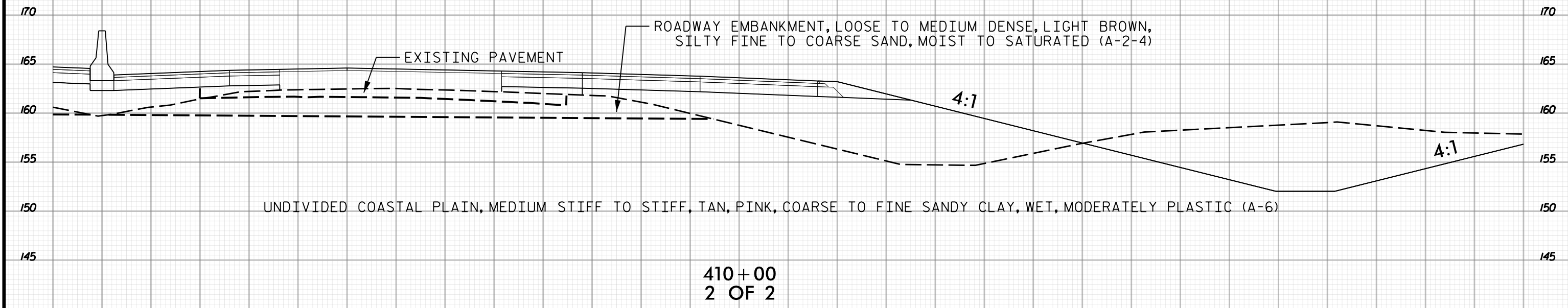
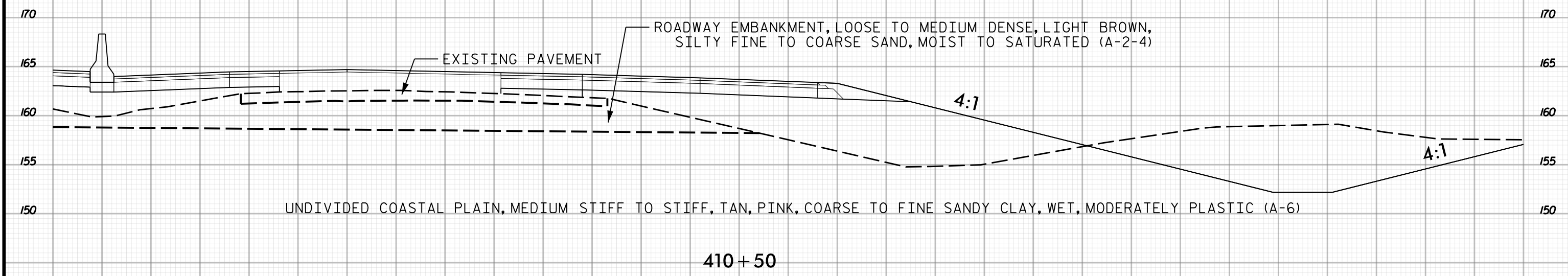

5 0 5 10 15 20 25 30 35 40 45 50 55 60 65 70 75 80 85 90 95 100 105 110 115 120 125 130 135 140 145

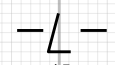



140 135 130 125 120 115 110 105 100 95 90 85 80 75 70 65 60 55 50 45 40 35 30 25 20 15 10 5 0 5

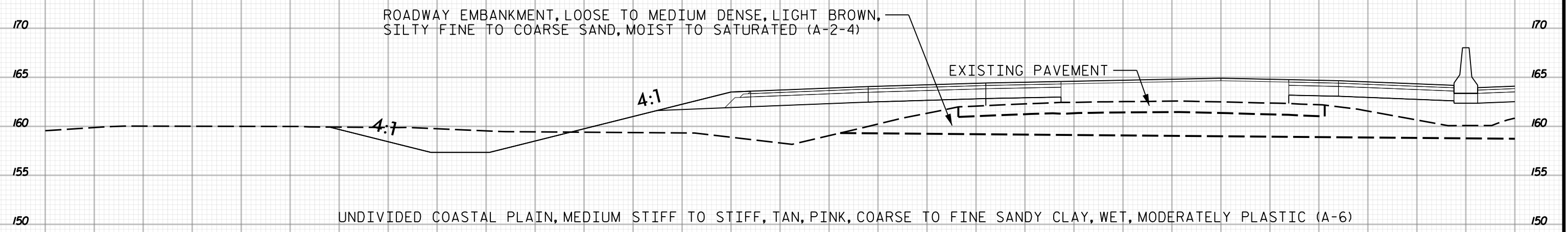

411+50

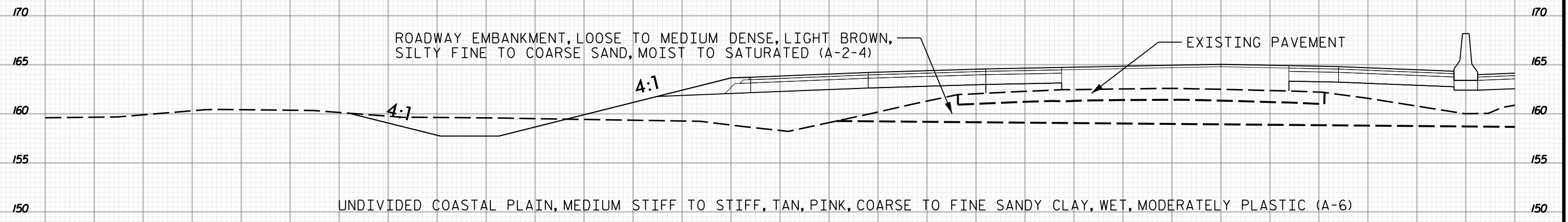

411+00
1 OF 2

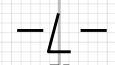

140 135 130 125 120 115 110 105 100 95 90 85 80 75 70 65 60 55 50 45 40 35 30 25 20 15 10 5 0 5



5 0 5 10 15 20 25 30 35 40 45 50 55 60 65 70 75 80 85 90 95 100 105 110 115 120 125 130 135 140 145

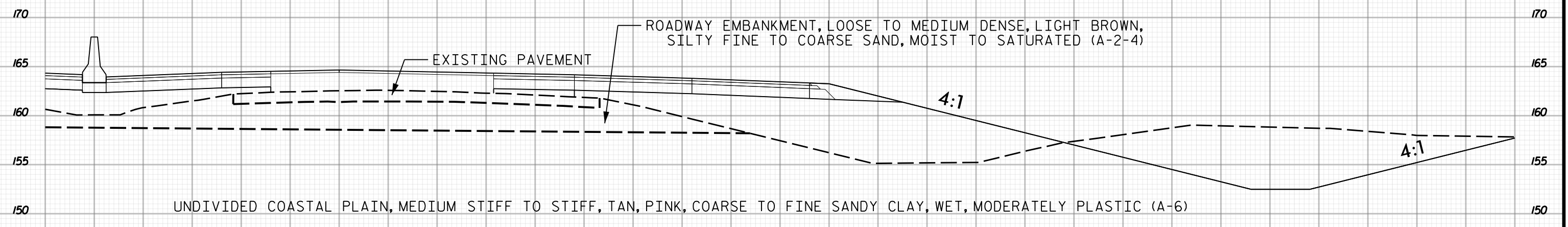

411+50

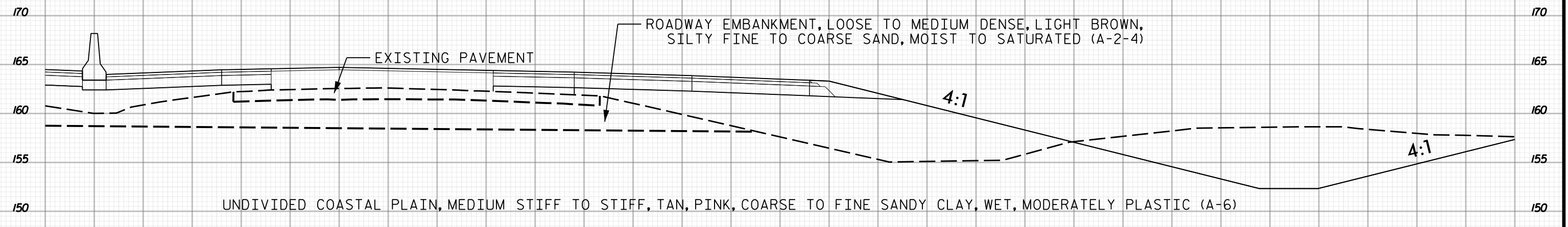

411+00
2 OF 2

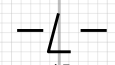

5 0 5 10 15 20 25 30 35 40 45 50 55 60 65 70 75 80 85 90 95 100 105 110 115 120 125 130 135 140 145

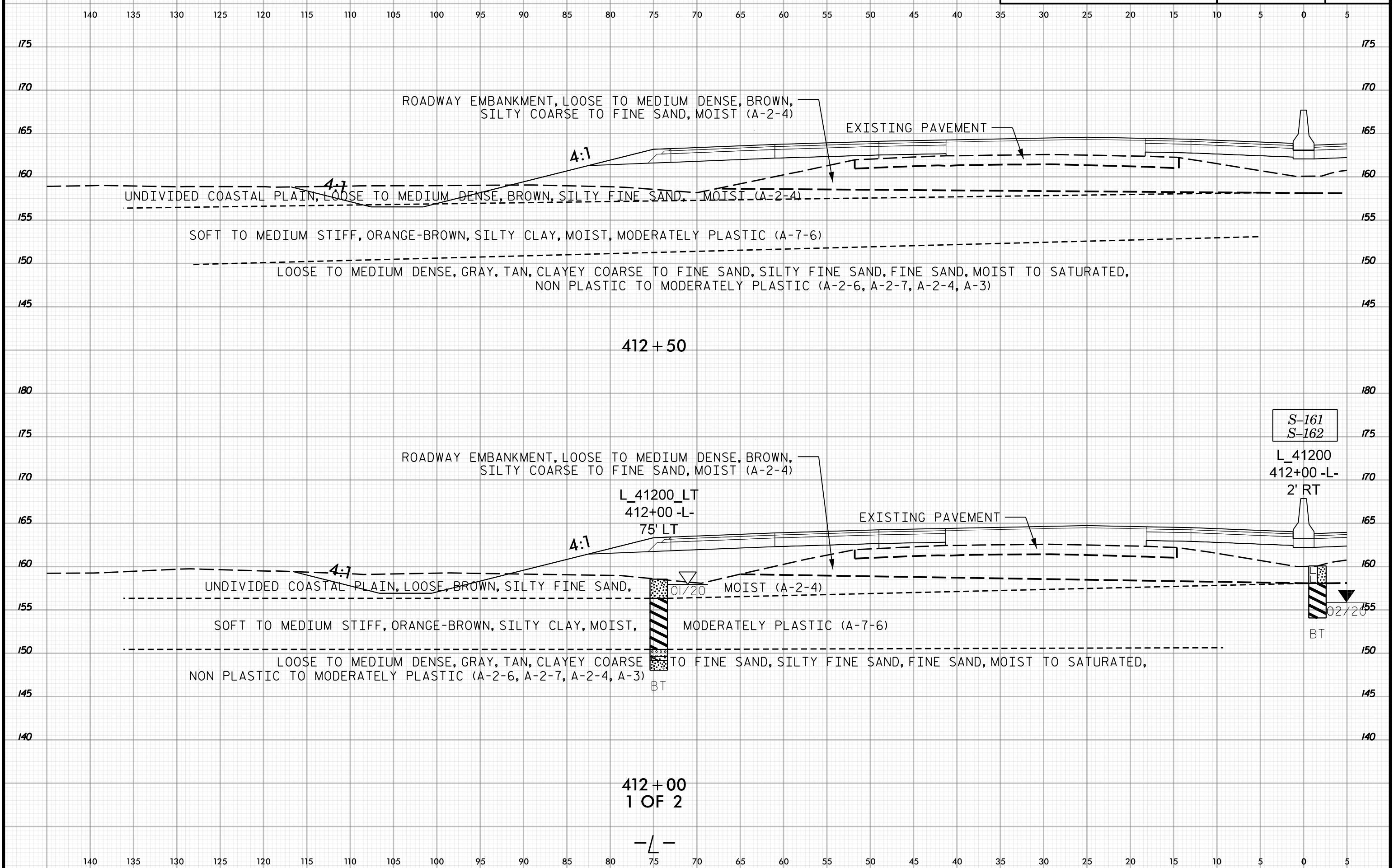

ROADWAY EMBANKMENT, LOOSE TO MEDIUM DENSE, BROWN, SILTY COARSE TO FINE SAND, MOIST (A-2-4)

EXISTING PAVEMENT

4:1

UNDIVIDED COASTAL PLAIN, LOOSE TO MEDIUM DENSE, BROWN, SILTY FINE SAND, MOIST (A-2-4)

SOFT TO MEDIUM STIFF, ORANGE-BROWN, SILTY CLAY, MOIST, MODERATELY PLASTIC (A-7-6)

LOOSE TO MEDIUM DENSE, GRAY, TAN, CLAYEY COARSE TO FINE SAND, SILTY FINE SAND, FINE SAND, MOIST TO SATURATED, NON PLASTIC TO MODERATELY PLASTIC (A-2-6, A-2-7, A-2-4, A-3)

412 + 50

ROADWAY EMBANKMENT, LOOSE TO MEDIUM DENSE, BROWN, SILTY COARSE TO FINE SAND, MOIST (A-2-4)

EXISTING PAVEMENT

4:1

L_41200_LT
412+00 -L-
75' LT

UNDIVIDED COASTAL PLAIN, LOOSE, BROWN, SILTY FINE SAND, MOIST (A-2-4)

SOFT TO MEDIUM STIFF, ORANGE-BROWN, SILTY CLAY, MOIST, MODERATELY PLASTIC (A-7-6)

LOOSE TO MEDIUM DENSE, GRAY, TAN, CLAYEY COARSE TO FINE SAND, SILTY FINE SAND, FINE SAND, MOIST TO SATURATED, NON PLASTIC TO MODERATELY PLASTIC (A-2-6, A-2-7, A-2-4, A-3)

412 + 00
1 OF 2

-L-

S-161
S-162

L_41200
412+00 -L-
2' RT

BT

BT

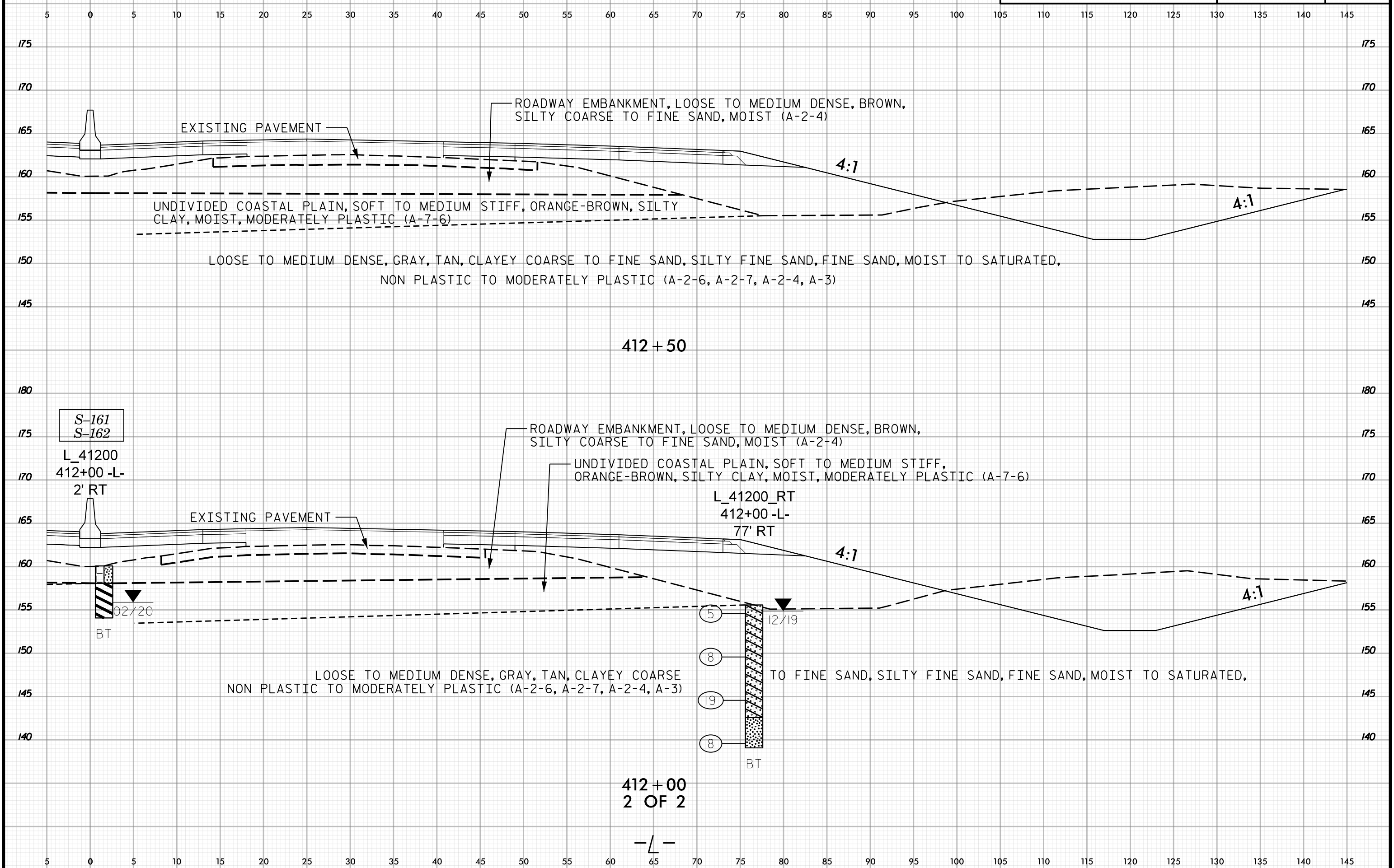
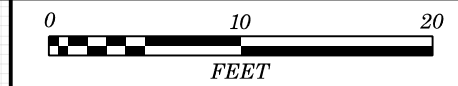

412 + 50

412 + 00
2 OF 2

-L-

S-161
S-162

L_41200
412+00 -L-
2' RT

L_41200_RT
412+00 -L-
77' RT

02/20
BT

5
8
19
8
BT

EXISTING PAVEMENT

ROADWAY EMBANKMENT, LOOSE TO MEDIUM DENSE, BROWN,
SILTY COARSE TO FINE SAND, MOIST (A-2-4)

UNDIVIDED COASTAL PLAIN, SOFT TO MEDIUM STIFF, ORANGE-BROWN, SILTY
CLAY, MOIST, MODERATELY PLASTIC (A-7-6)

LOOSE TO MEDIUM DENSE, GRAY, TAN, CLAYEY COARSE TO FINE SAND, SILTY FINE SAND, FINE SAND, MOIST TO SATURATED,
NON PLASTIC TO MODERATELY PLASTIC (A-2-6, A-2-7, A-2-4, A-3)

ROADWAY EMBANKMENT, LOOSE TO MEDIUM DENSE, BROWN,
SILTY COARSE TO FINE SAND, MOIST (A-2-4)

UNDIVIDED COASTAL PLAIN, SOFT TO MEDIUM STIFF,
ORANGE-BROWN, SILTY CLAY, MOIST, MODERATELY PLASTIC (A-7-6)

EXISTING PAVEMENT

LOOSE TO MEDIUM DENSE, GRAY, TAN, CLAYEY COARSE
NON PLASTIC TO MODERATELY PLASTIC (A-2-6, A-2-7, A-2-4, A-3)

TO FINE SAND, SILTY FINE SAND, FINE SAND, MOIST TO SATURATED,

4:1

4:1

4:1

4:1



140 135 130 125 120 115 110 105 100 95 90 85 80 75 70 65 60 55 50 45 40 35 30 25 20 15 10 5 0 5

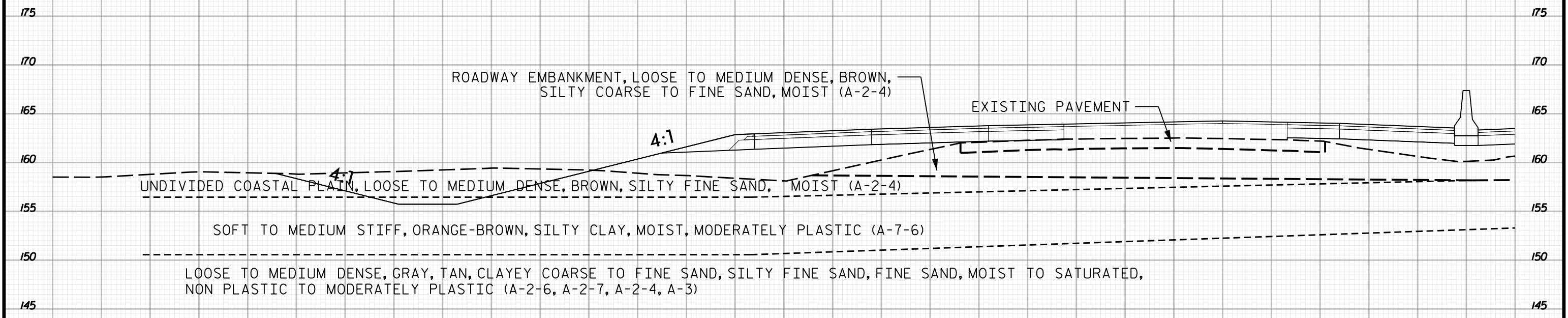

413 + 50

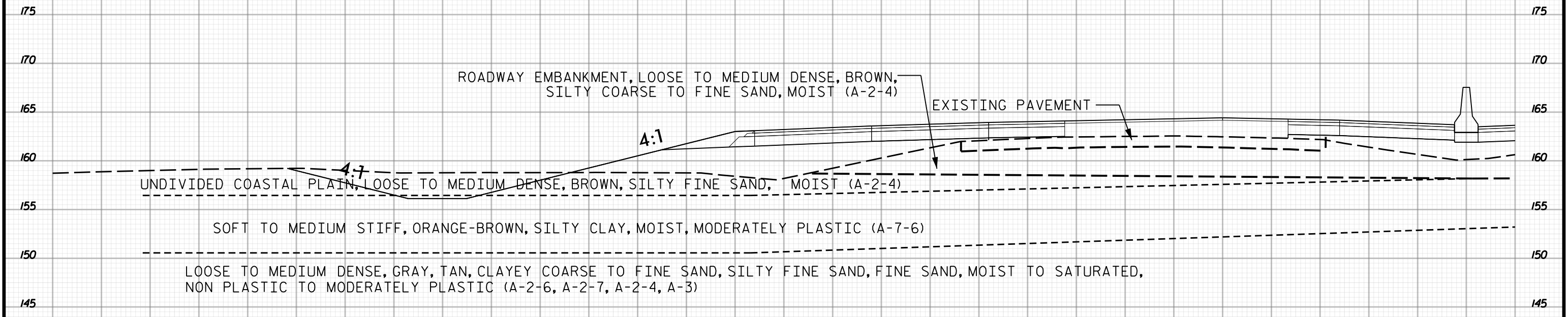

413 + 00
1 OF 2

140 135 130 125 120 115 110 105 100 95 90 85 80 75 70 65 60 55 50 45 40 35 30 25 20 15 10 5 0 5

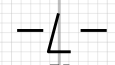

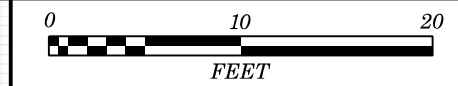

5 0 5 10 15 20 25 30 35 40 45 50 55 60 65 70 75 80 85 90 95 100 105 110 115 120 125 130 135 140 145

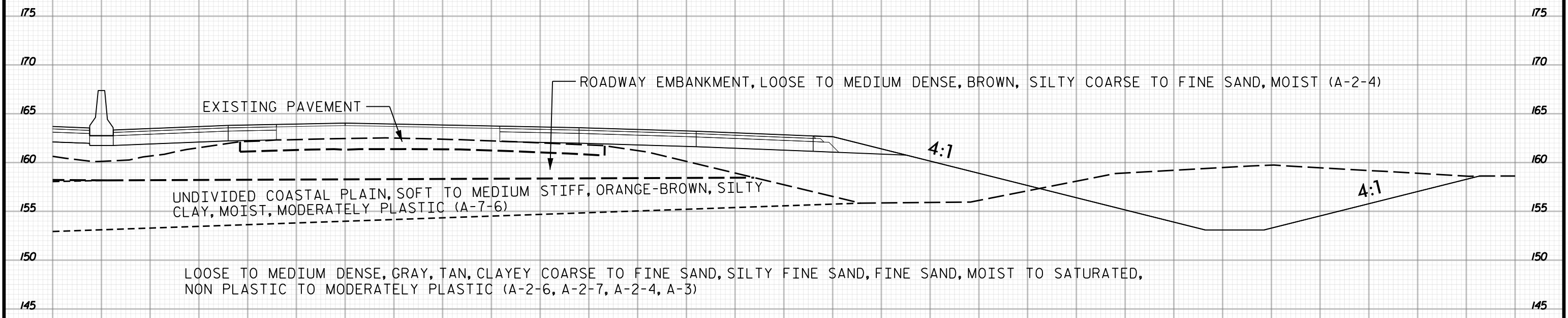

413+50

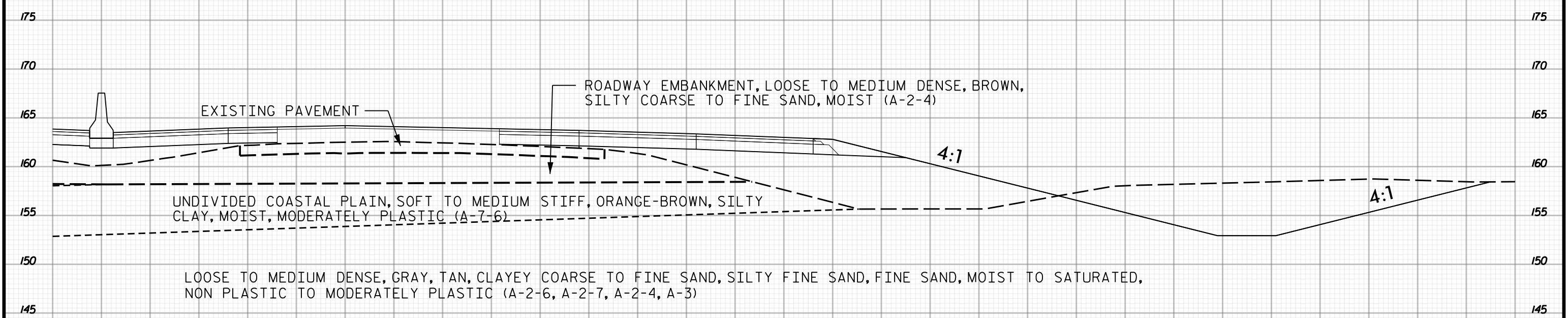

413+00
2 OF 2

5 0 5 10 15 20 25 30 35 40 45 50 55 60 65 70 75 80 85 90 95 100 105 110 115 120 125 130 135 140 145

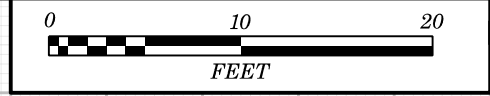

PROJ. REFERENCE NO.	SHEET NO.
I-5987A	746

140 135 130 125 120 115 110 105 100 95 90 85 80 75 70 65 60 55 50 45 40 35 30 25 20 15 10 5 0 5

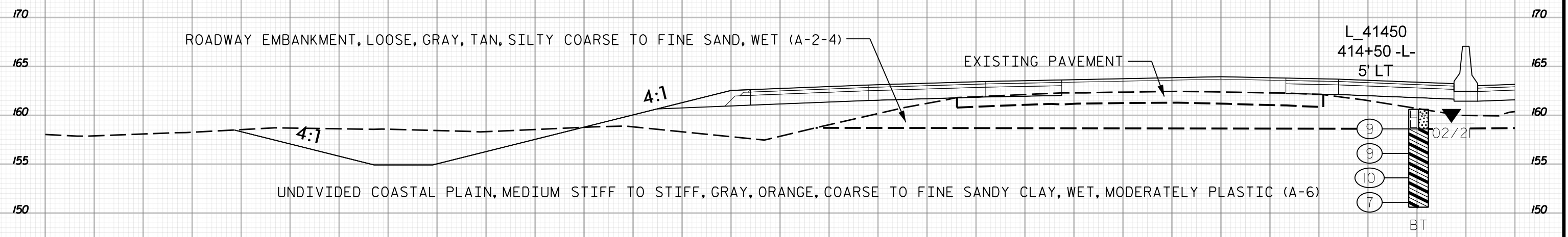

414 + 50

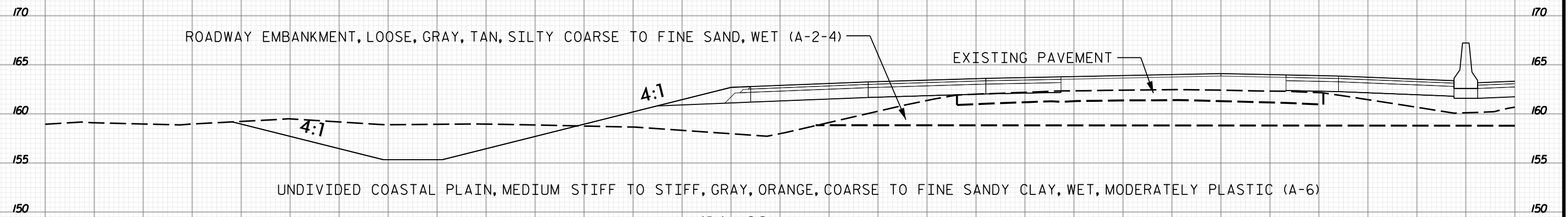

414 + 00
1 OF 2

-L-

140 135 130 125 120 115 110 105 100 95 90 85 80 75 70 65 60 55 50 45 40 35 30 25 20 15 10 5 0 5

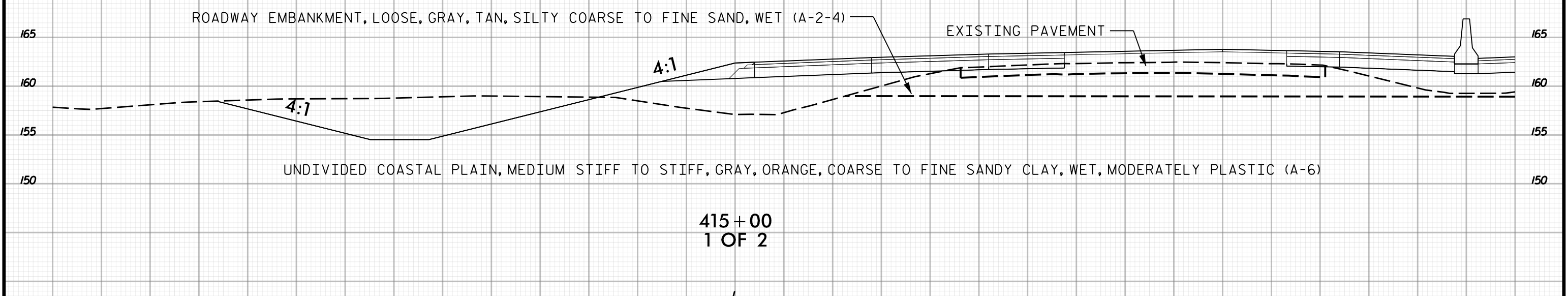
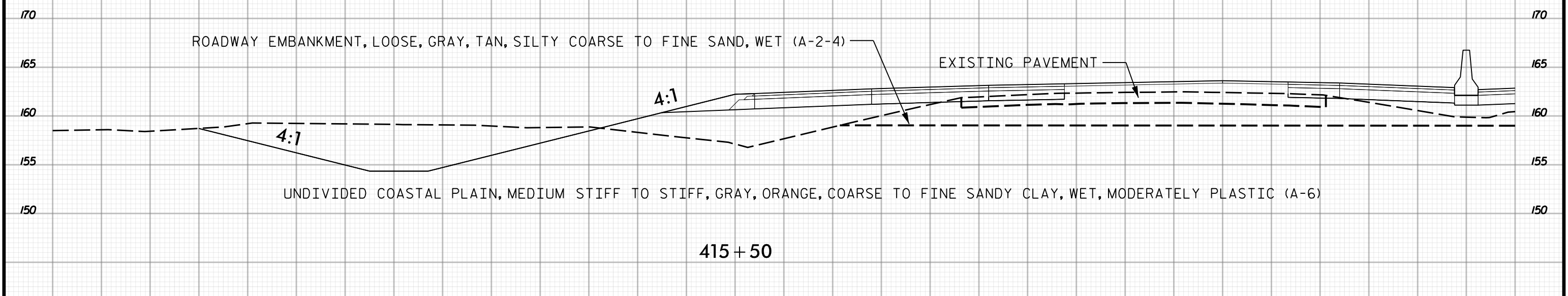
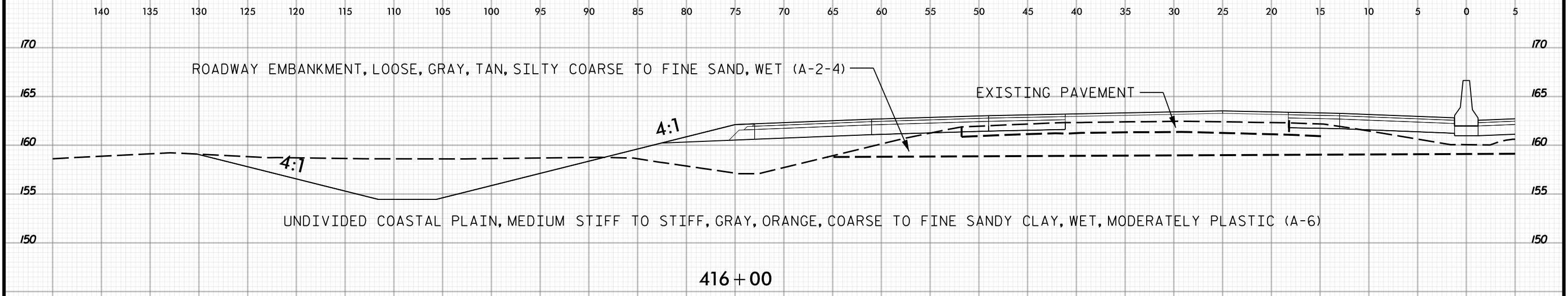

415 + 00
1 OF 2

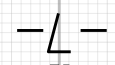

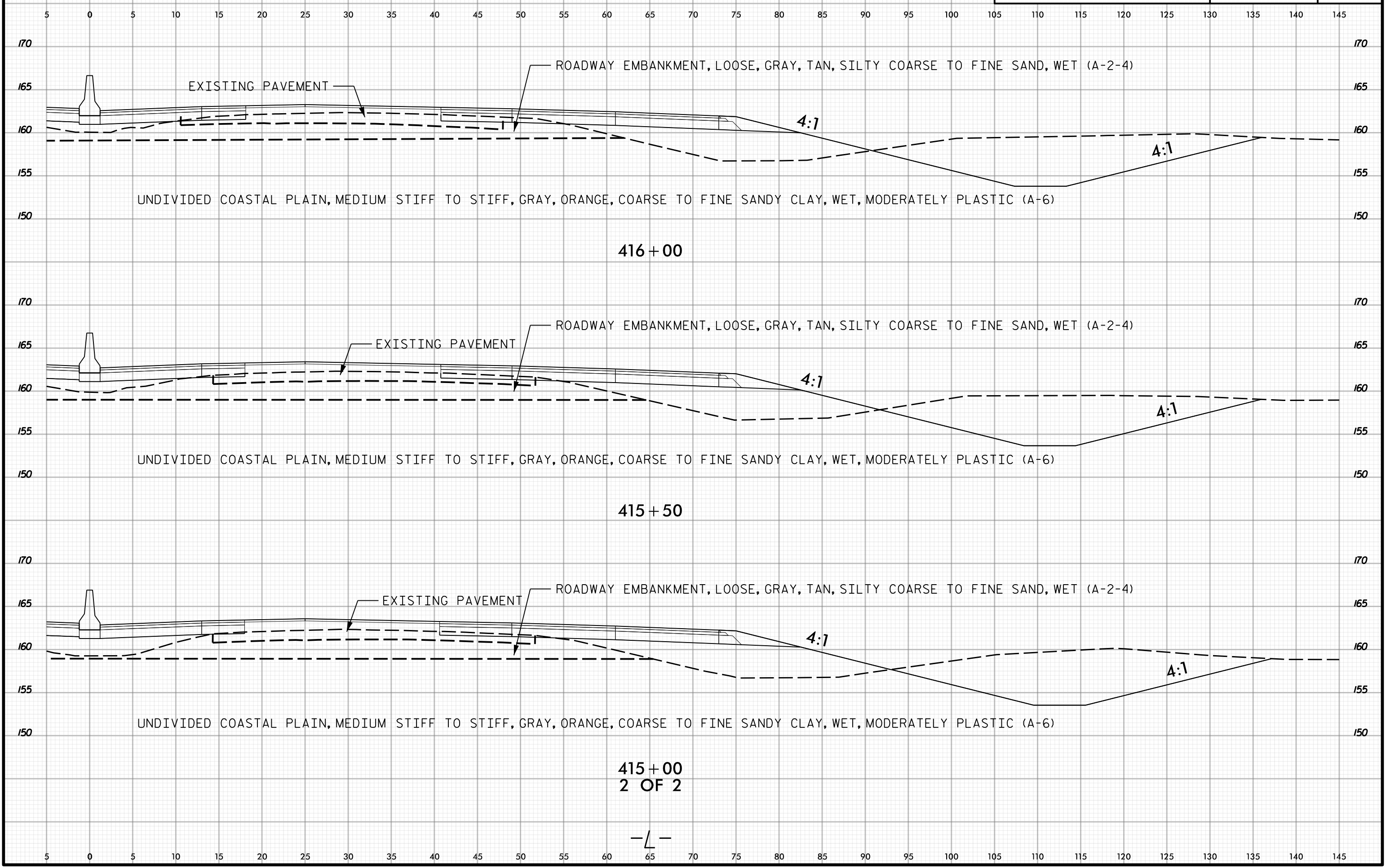

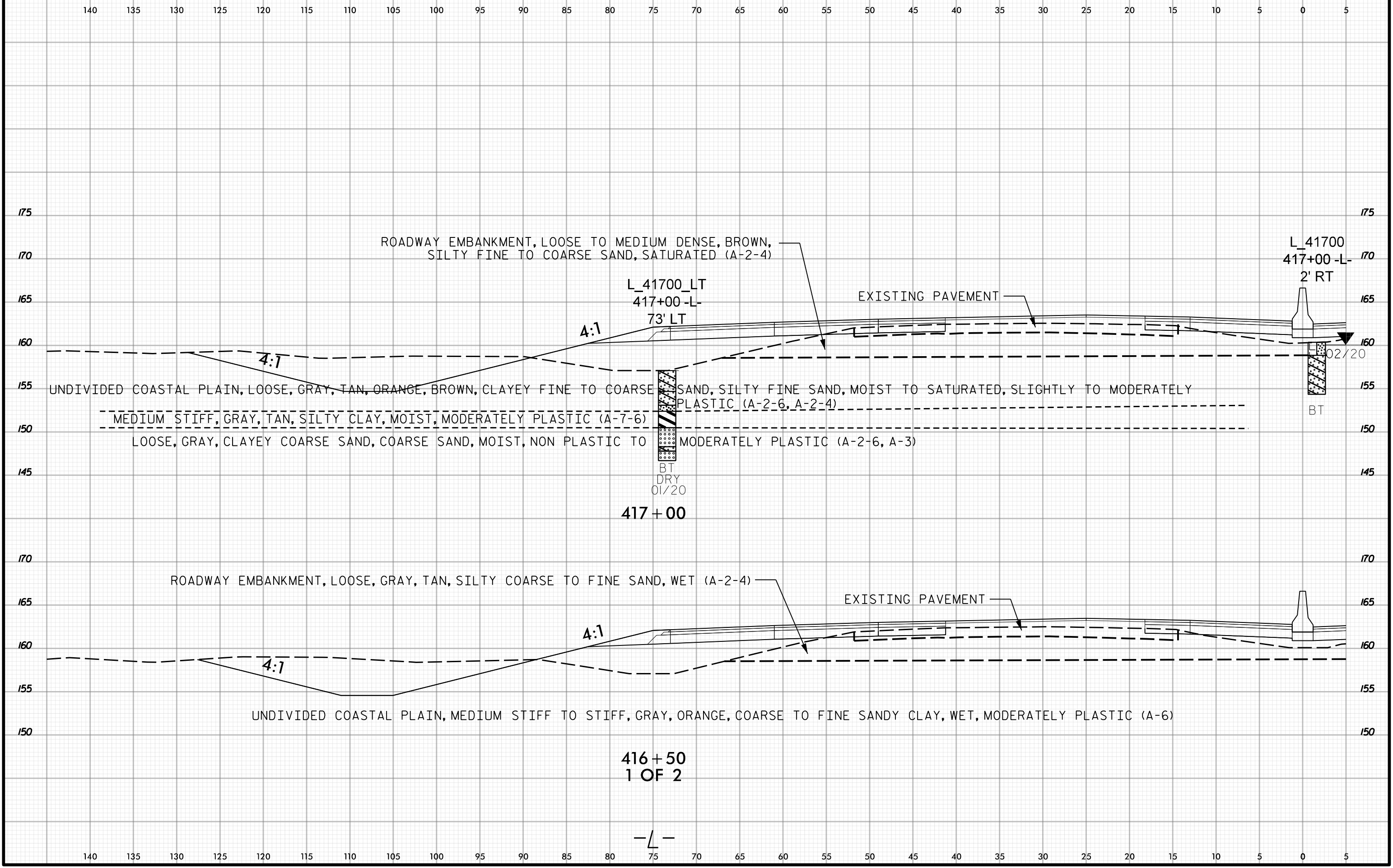
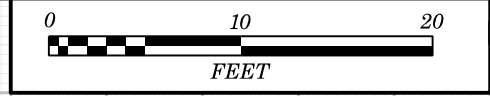

ROADWAY EMBANKMENT, LOOSE TO MEDIUM DENSE, BROWN, SILTY FINE TO COARSE SAND, SATURATED (A-2-4)

L_41700_LT
417+00 -L-
73' LT

EXISTING PAVEMENT

L_41700
417+00 -L-
2' RT

4:1

4:1

UNDIVIDED COASTAL PLAIN, LOOSE, GRAY, TAN, ORANGE, BROWN, CLAYEY FINE TO COARSE SAND, SILTY FINE SAND, MOIST TO SATURATED, SLIGHTLY TO MODERATELY PLASTIC (A-2-6, A-2-4)

MEDIUM STIFF, GRAY, TAN, SILTY CLAY, MOIST, MODERATELY PLASTIC (A-7-6)

LOOSE, GRAY, CLAYEY COARSE SAND, COARSE SAND, MOIST, NON PLASTIC TO MODERATELY PLASTIC (A-2-6, A-3)

BT
DRY
01/20

417+00

ROADWAY EMBANKMENT, LOOSE, GRAY, TAN, SILTY COARSE TO FINE SAND, WET (A-2-4)

EXISTING PAVEMENT

4:1

4:1

UNDIVIDED COASTAL PLAIN, MEDIUM STIFF TO STIFF, GRAY, ORANGE, COARSE TO FINE SANDY CLAY, WET, MODERATELY PLASTIC (A-6)

416+50
1 OF 2

-L-

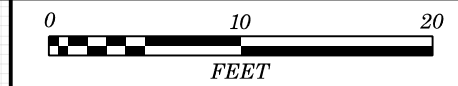

5 0 5 10 15 20 25 30 35 40 45 50 55 60 65 70 75 80 85 90 95 100 105 110 115 120 125 130 135 140 145

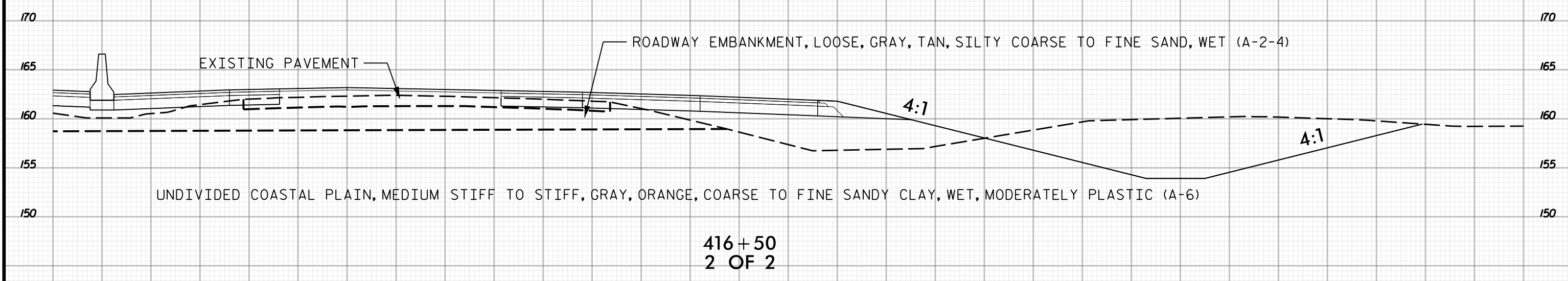
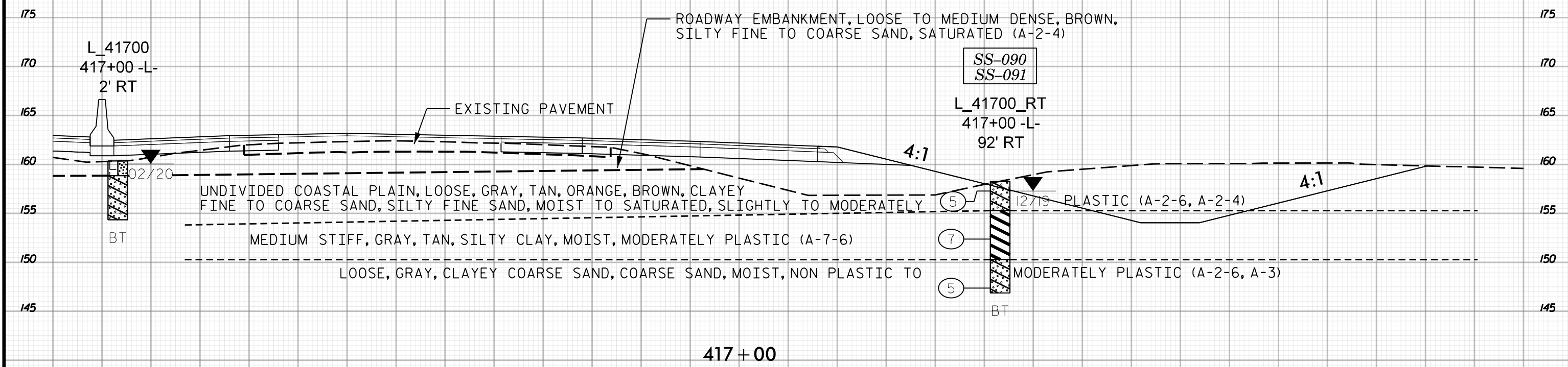

5 0 5 10 15 20 25 30 35 40 45 50 55 60 65 70 75 80 85 90 95 100 105 110 115 120 125 130 135 140 145



140 135 130 125 120 115 110 105 100 95 90 85 80 75 70 65 60 55 50 45 40 35 30 25 20 15 10 5 0 5

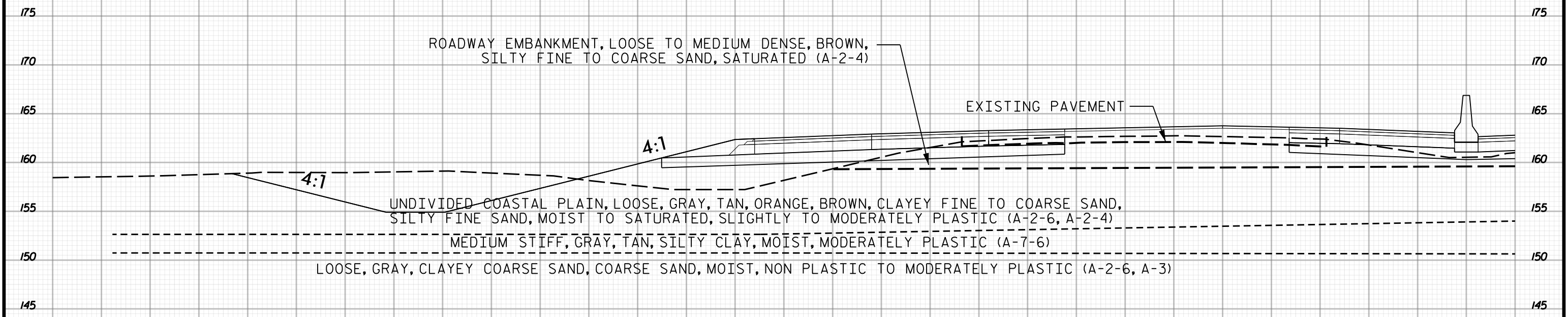

418 + 00

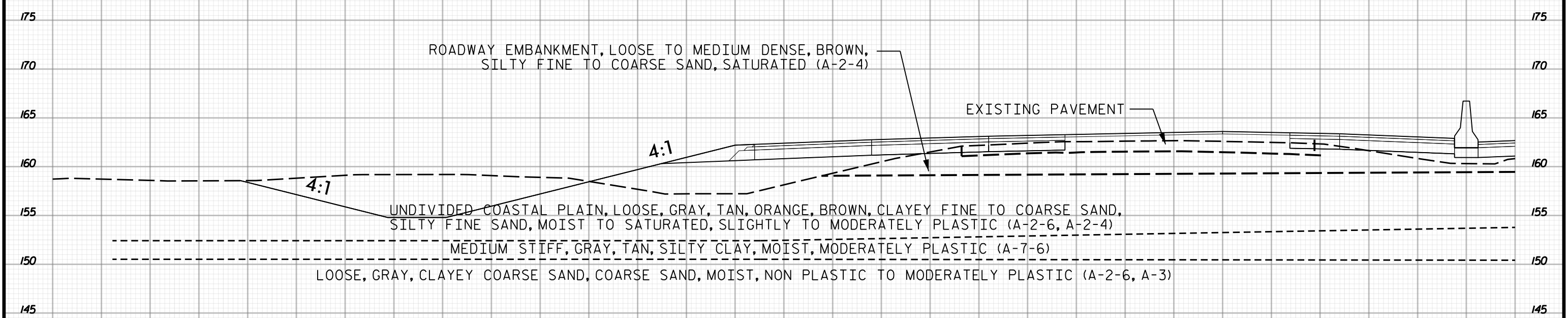

417 + 50
1 OF 2

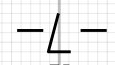

140 135 130 125 120 115 110 105 100 95 90 85 80 75 70 65 60 55 50 45 40 35 30 25 20 15 10 5 0 5

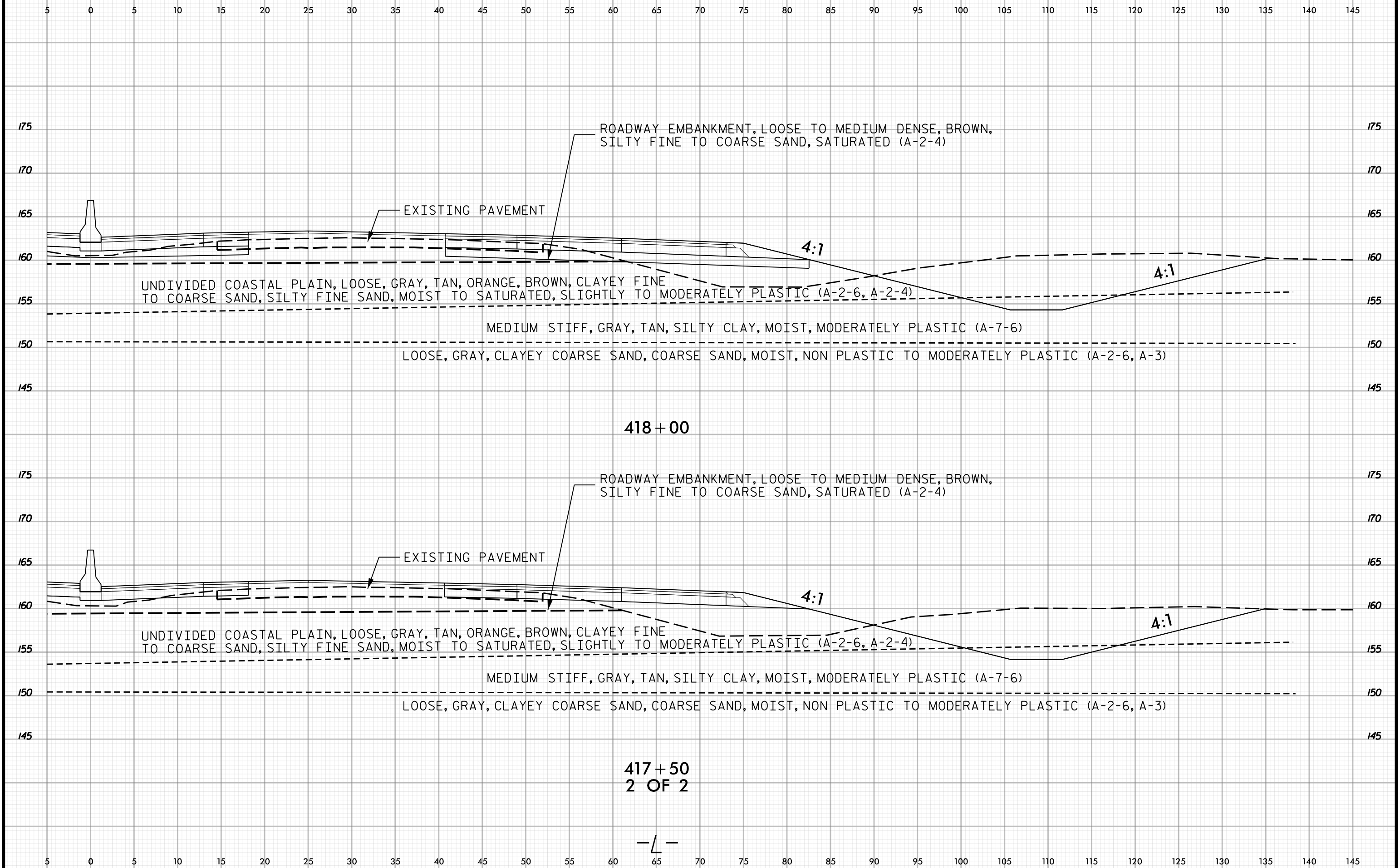



140 135 130 125 120 115 110 105 100 95 90 85 80 75 70 65 60 55 50 45 40 35 30 25 20 15 10 5 0 5

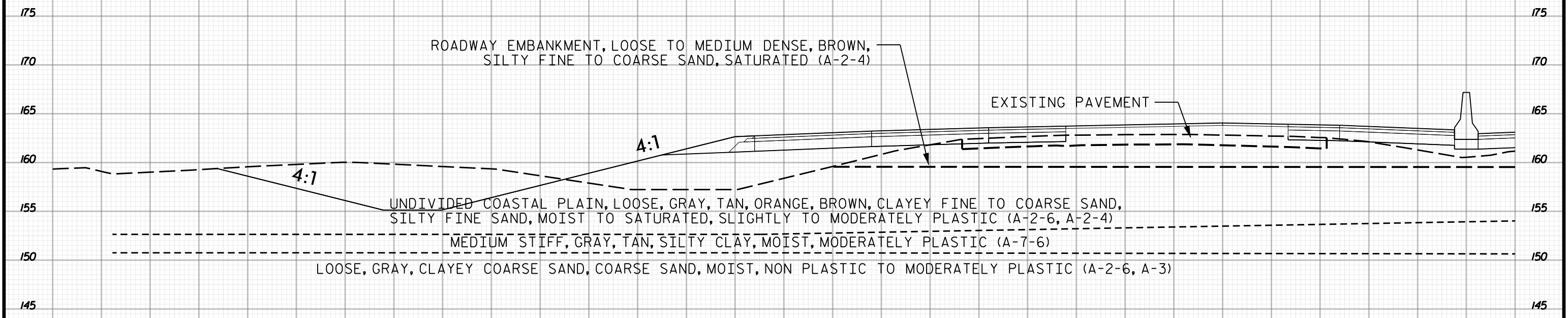

419 + 00

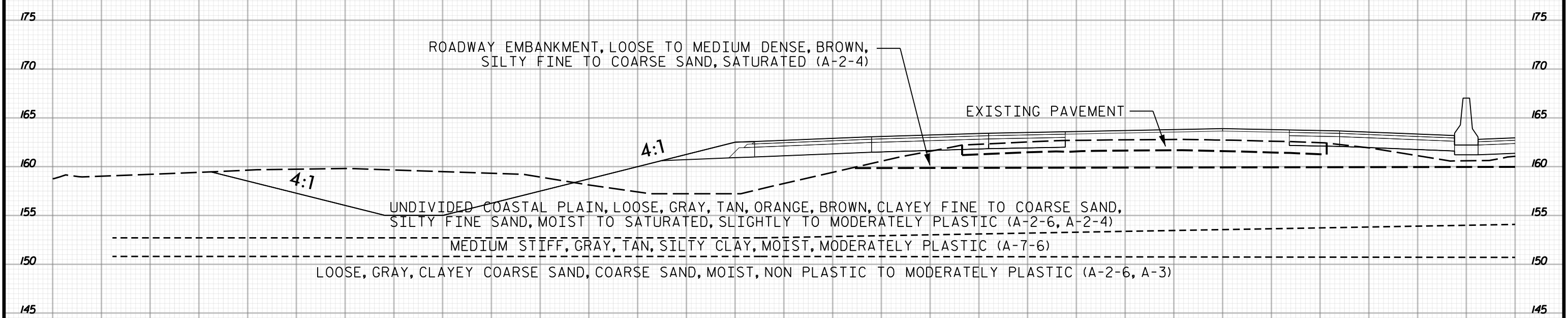

418 + 50
1 OF 2

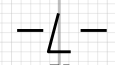

140 135 130 125 120 115 110 105 100 95 90 85 80 75 70 65 60 55 50 45 40 35 30 25 20 15 10 5 0 5

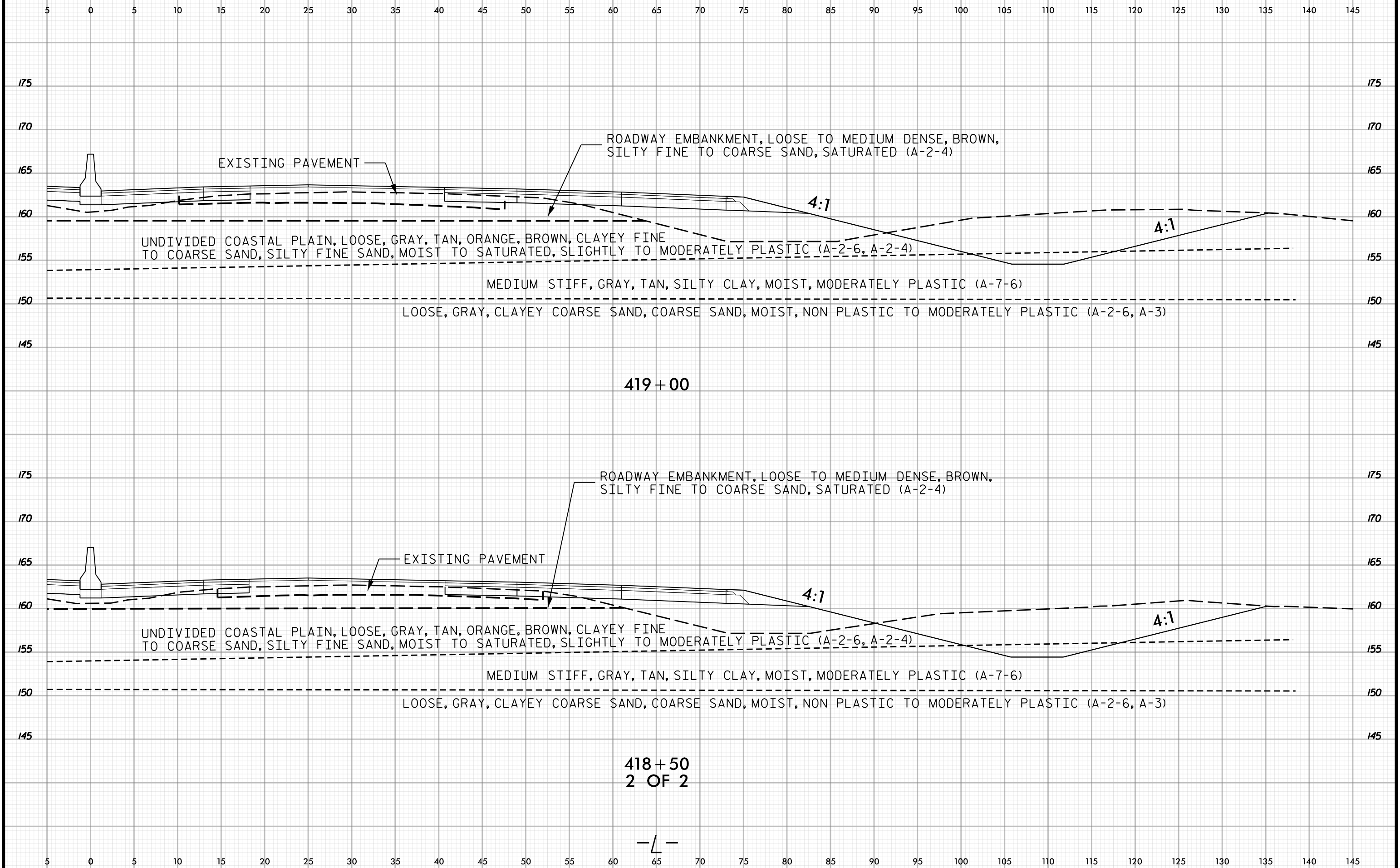

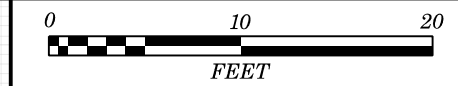

140 135 130 125 120 115 110 105 100 95 90 85 80 75 70 65 60 55 50 45 40 35 30 25 20 15 10 5 0 5

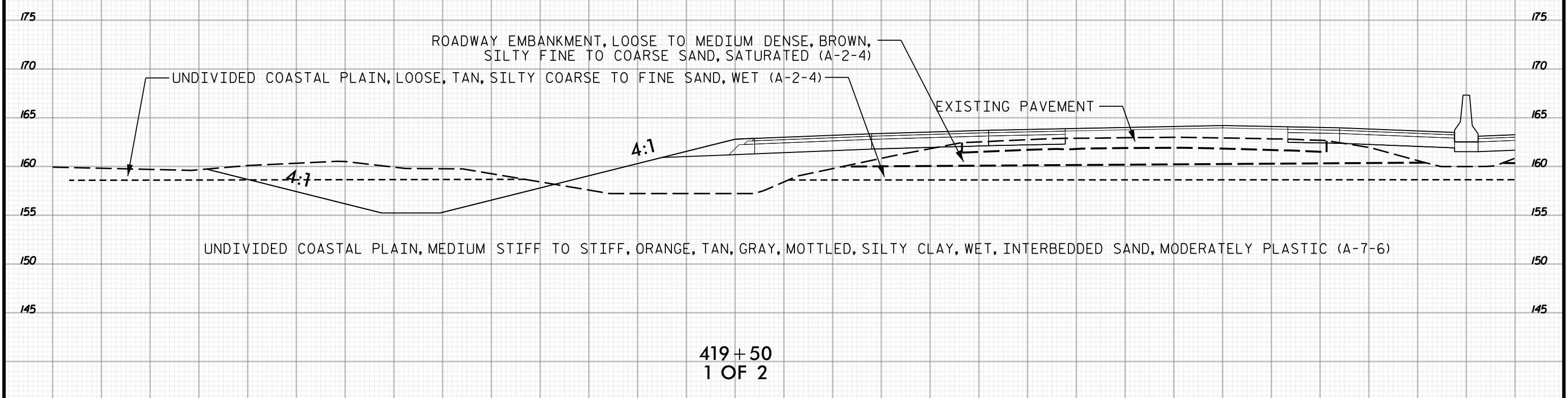
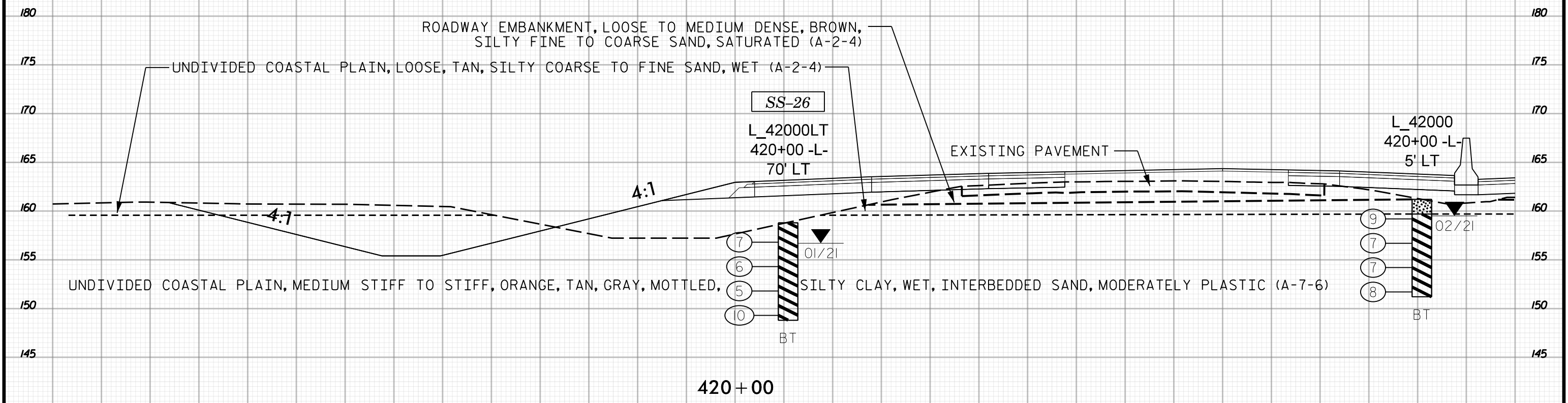

140 135 130 125 120 115 110 105 100 95 90 85 80 75 70 65 60 55 50 45 40 35 30 25 20 15 10 5 0 5

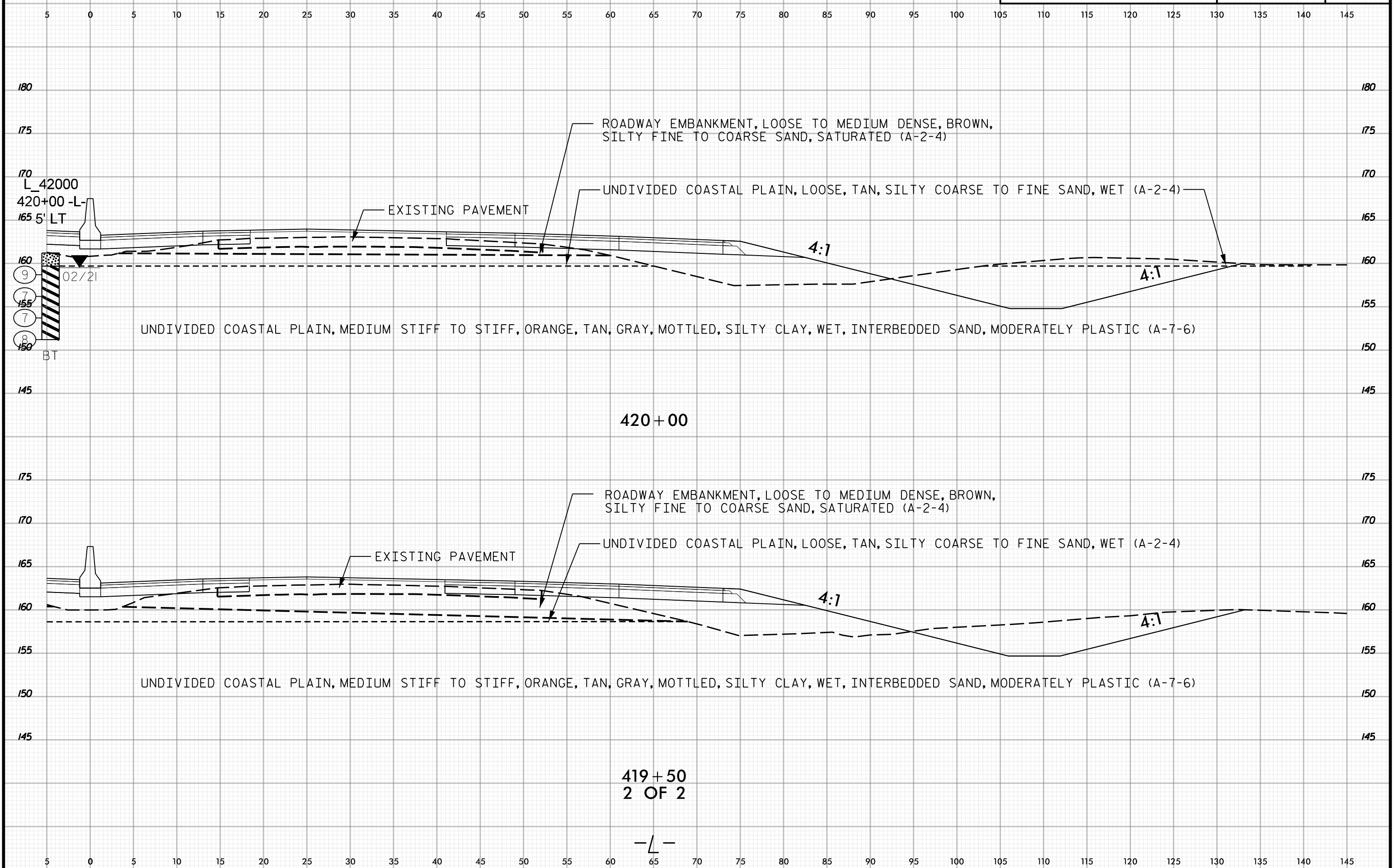

5 0 5 10 15 20 25 30 35 40 45 50 55 60 65 70 75 80 85 90 95 100 105 110 115 120 125 130 135 140 145

180 175 170 165 160 155 150 145

170
L_42000
420+00 -L-
165.5' LT

175 170 165 160 155 150 145

175 170 165 160 155 150 145

5 0 5 10 15 20 25 30 35 40 45 50 55 60 65 70 75 80 85 90 95 100 105 110 115 120 125 130 135 140 145

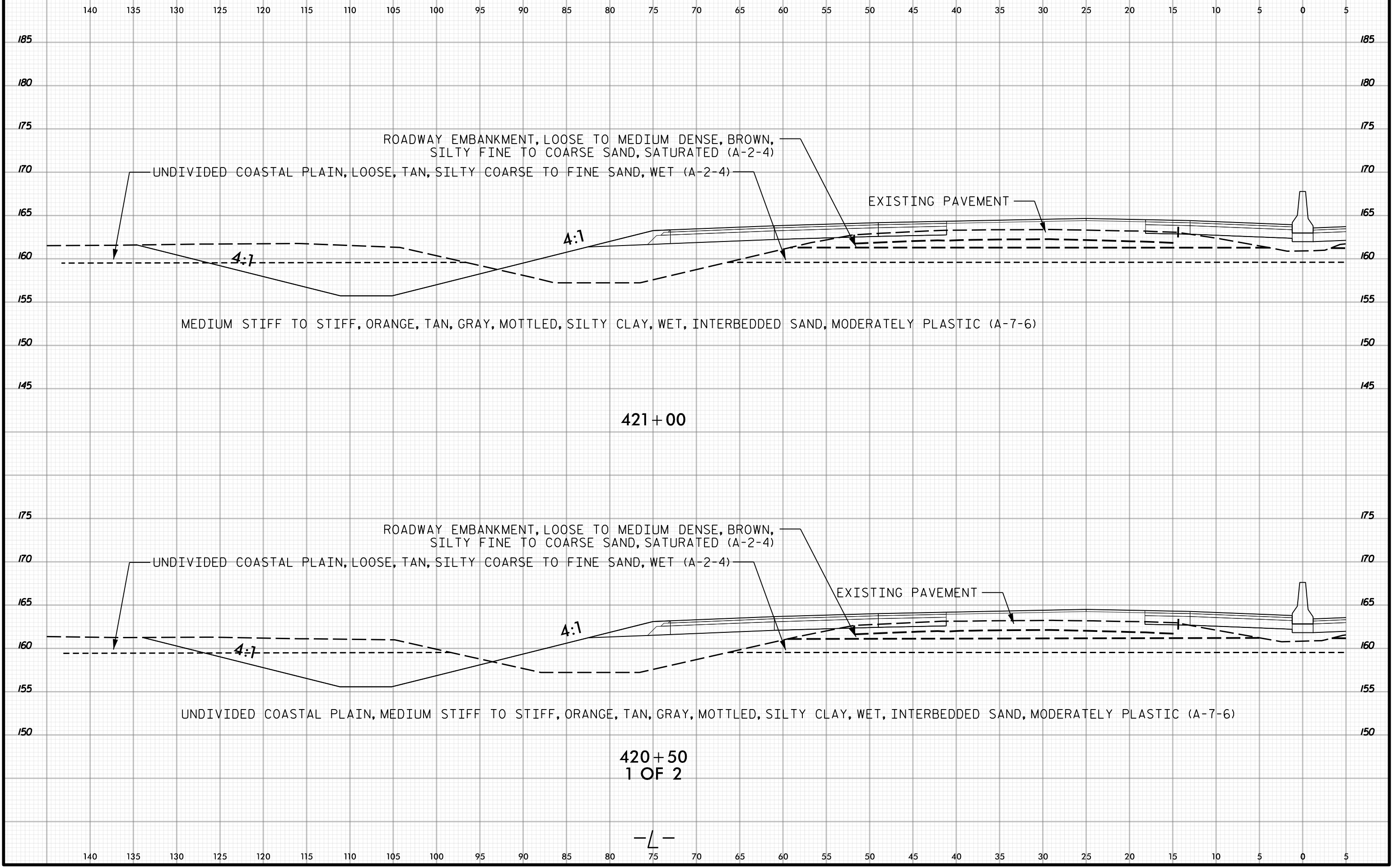

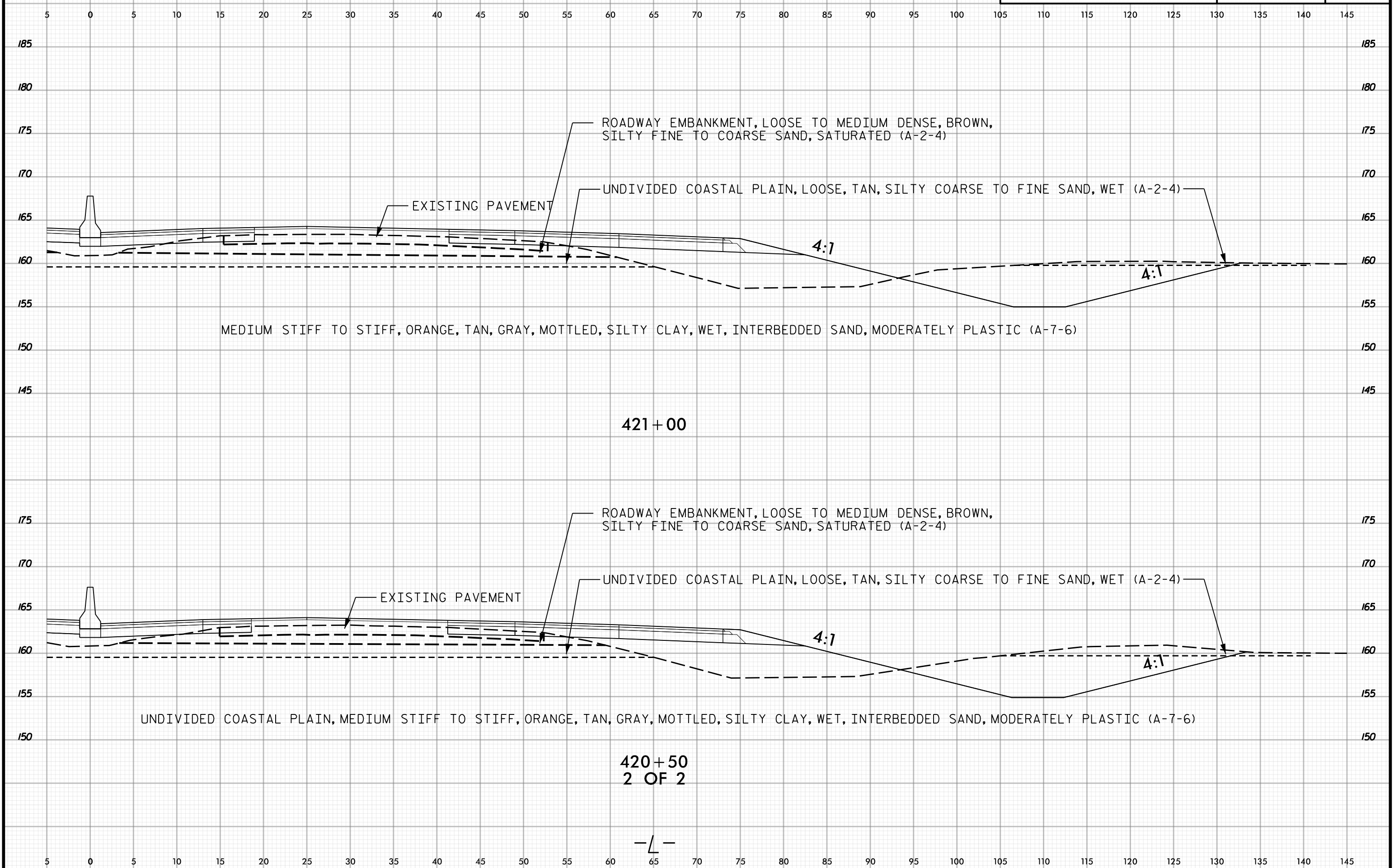

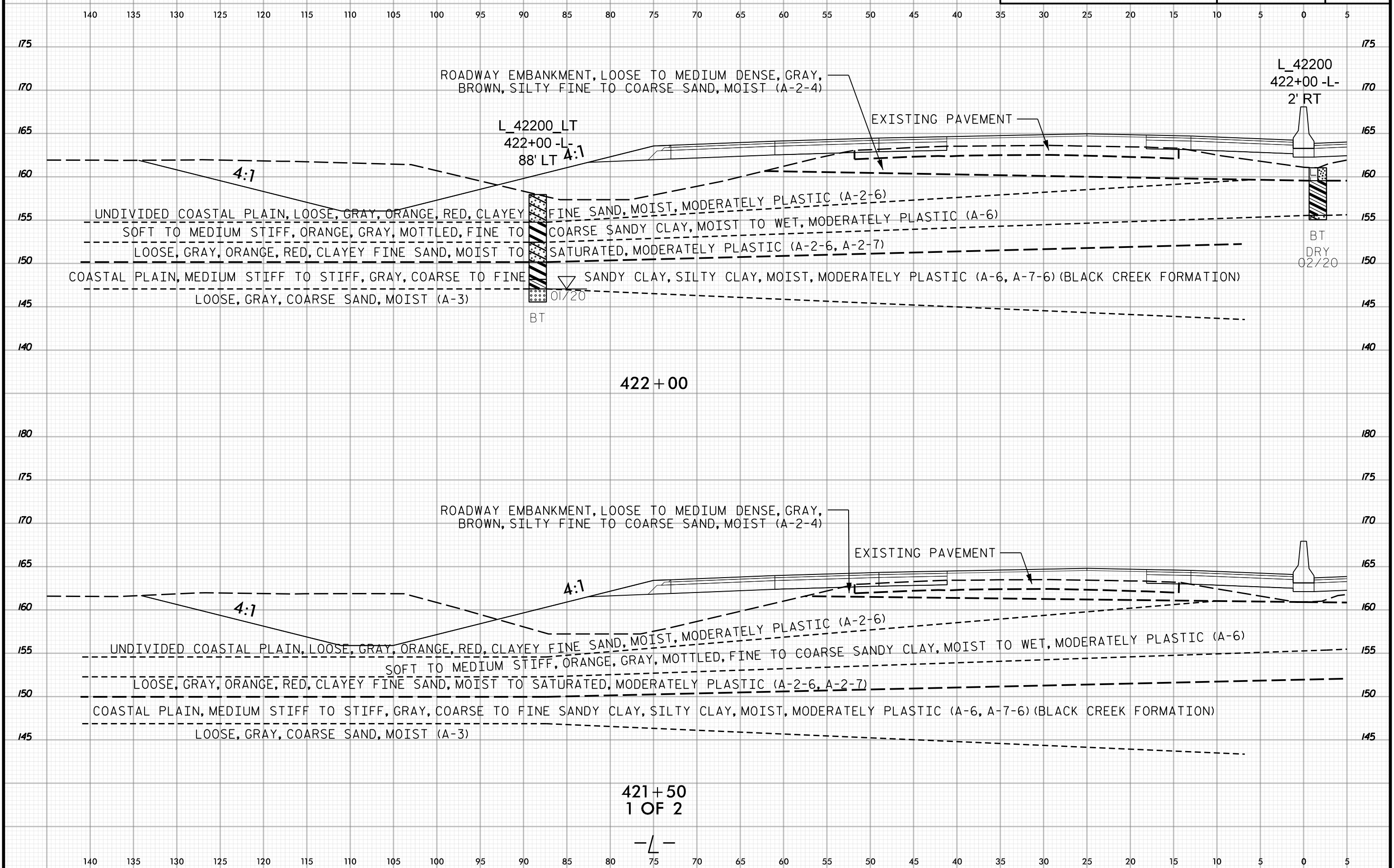

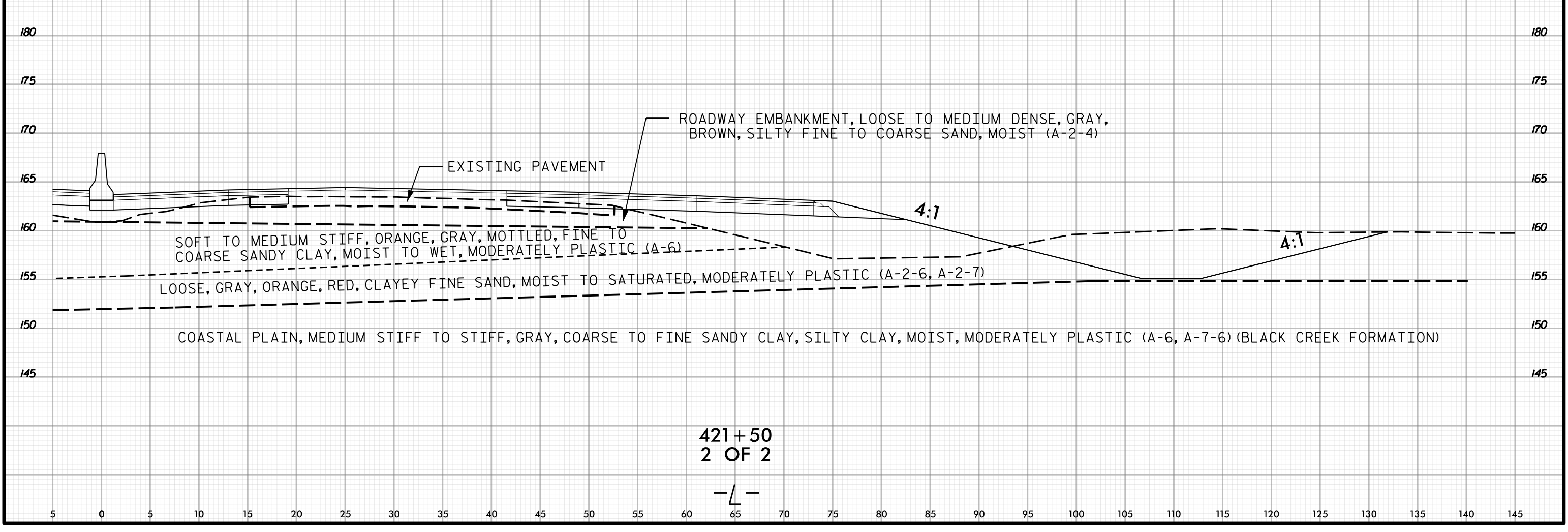
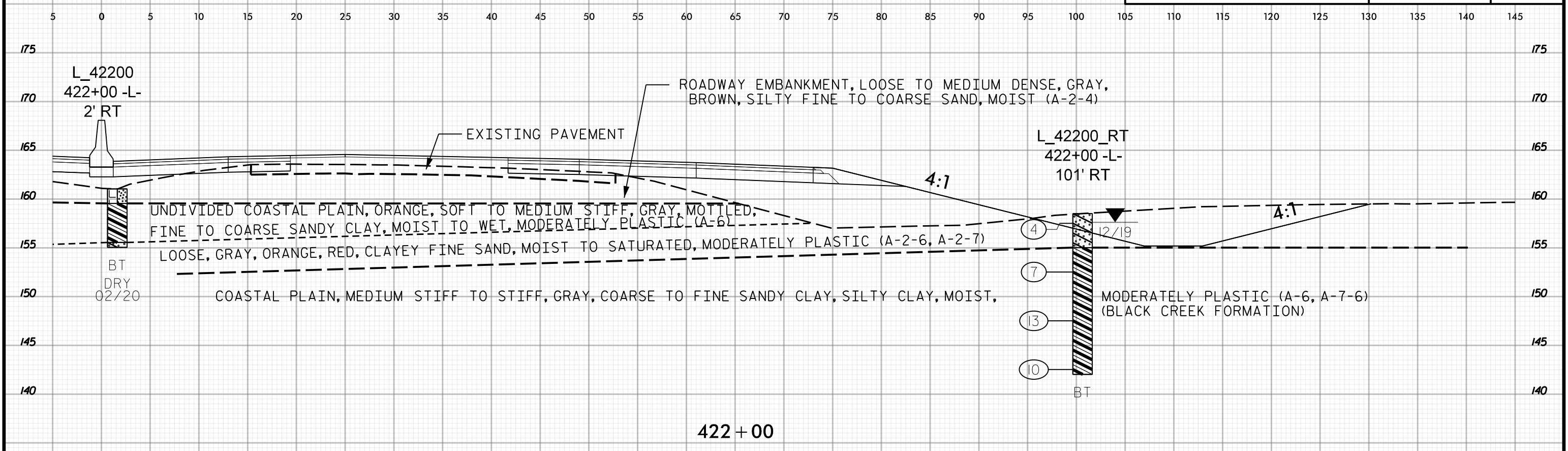
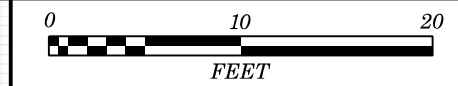

421+50
2 OF 2

-L-



140 135 130 125 120 115 110 105 100 95 90 85 80 75 70 65 60 55 50 45 40 35 30 25 20 15 10 5 0 5

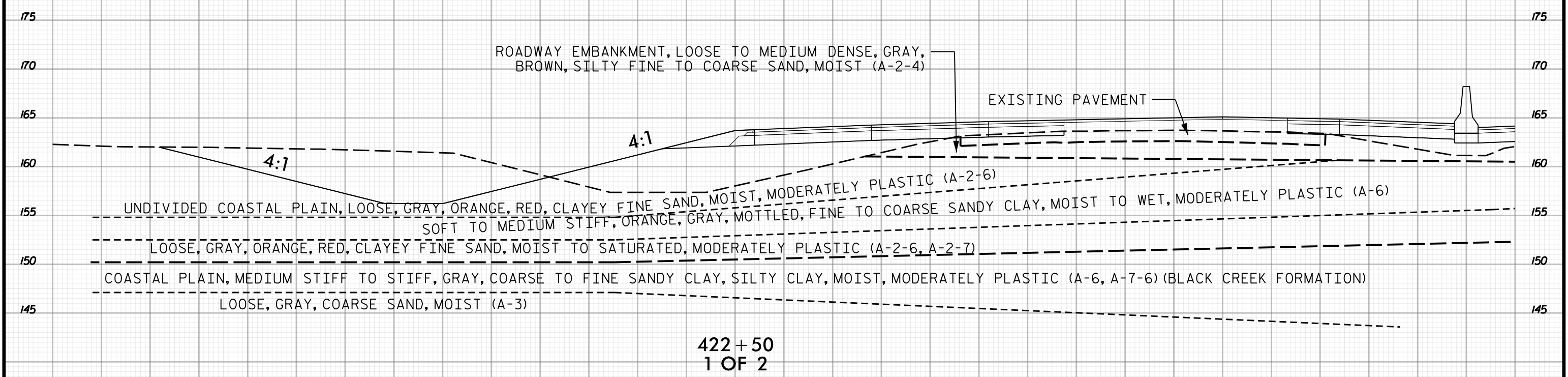
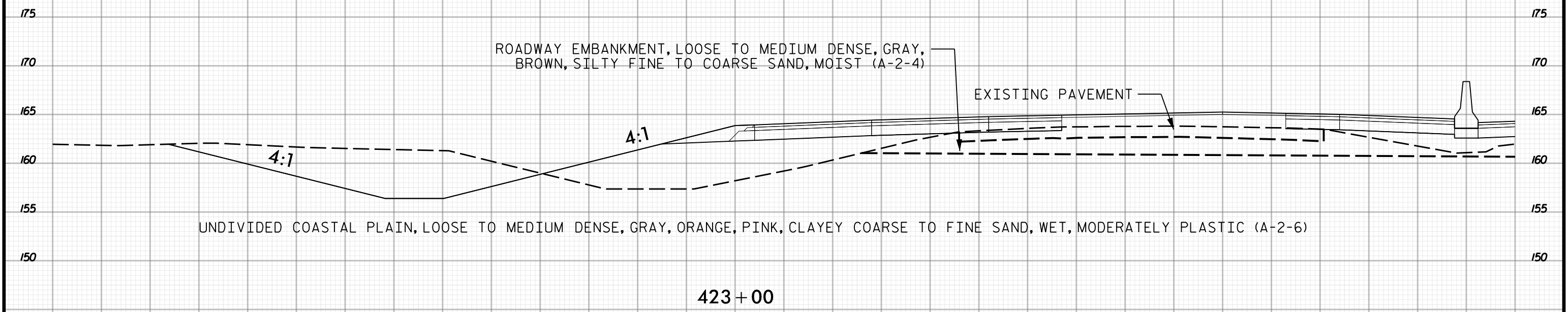

140 135 130 125 120 115 110 105 100 95 90 85 80 75 70 65 60 55 50 45 40 35 30 25 20 15 10 5 0 5



5 0 5 10 15 20 25 30 35 40 45 50 55 60 65 70 75 80 85 90 95 100 105 110 115 120 125 130 135 140 145

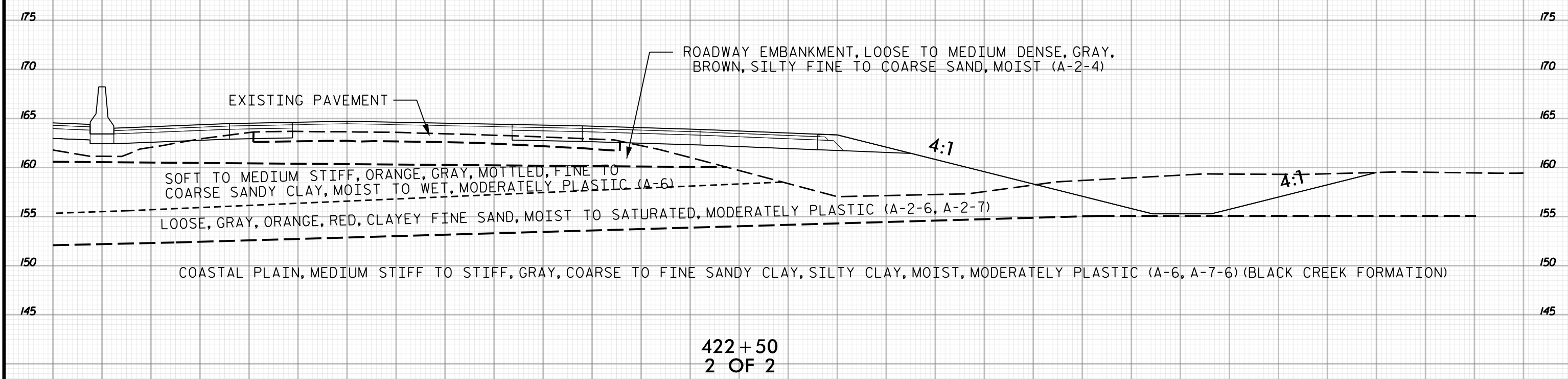
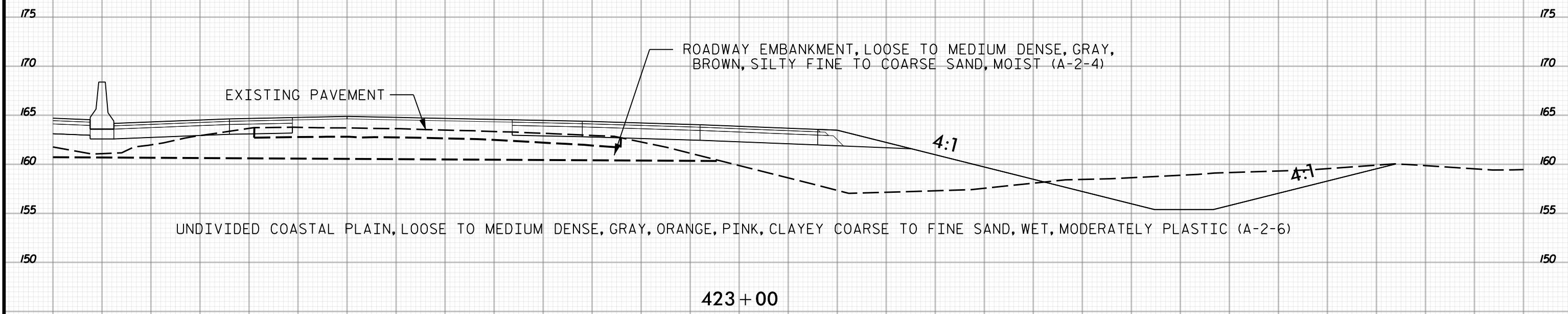

5 0 5 10 15 20 25 30 35 40 45 50 55 60 65 70 75 80 85 90 95 100 105 110 115 120 125 130 135 140 145



140 135 130 125 120 115 110 105 100 95 90 85 80 75 70 65 60 55 50 45 40 35 30 25 20 15 10 5 0 5

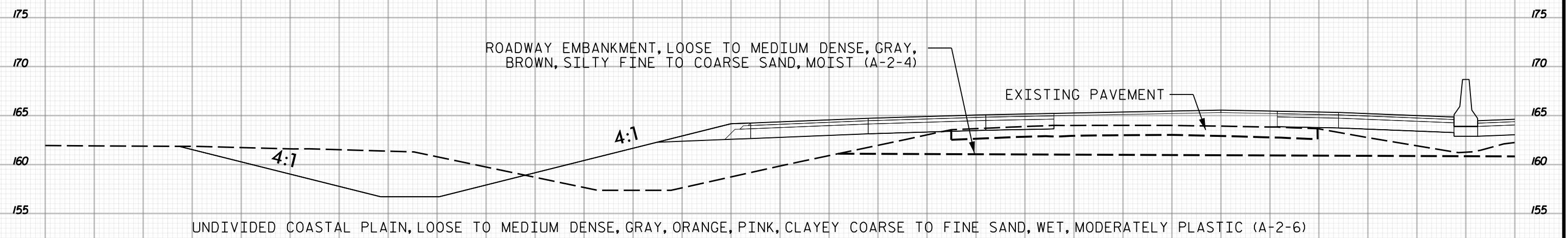

424+00

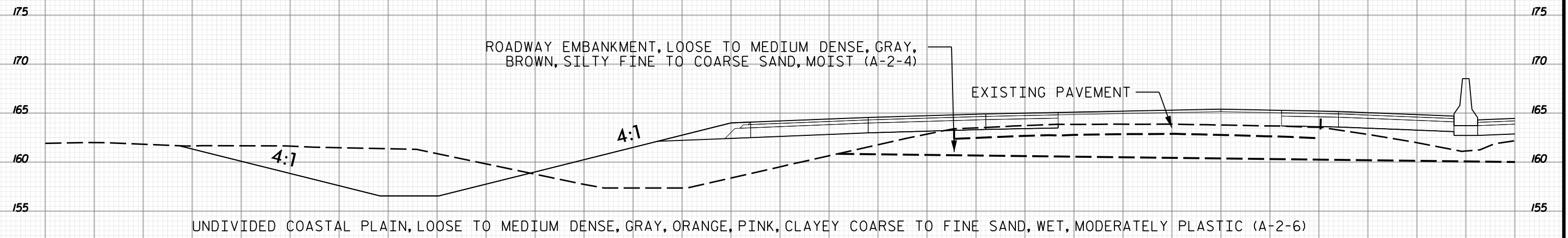

423+50
1 OF 2

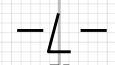

140 135 130 125 120 115 110 105 100 95 90 85 80 75 70 65 60 55 50 45 40 35 30 25 20 15 10 5 0 5



PROJ. REFERENCE NO.	SHEET NO.
I-5987A	765

5 0 5 10 15 20 25 30 35 40 45 50 55 60 65 70 75 80 85 90 95 100 105 110 115 120 125 130 135 140 145

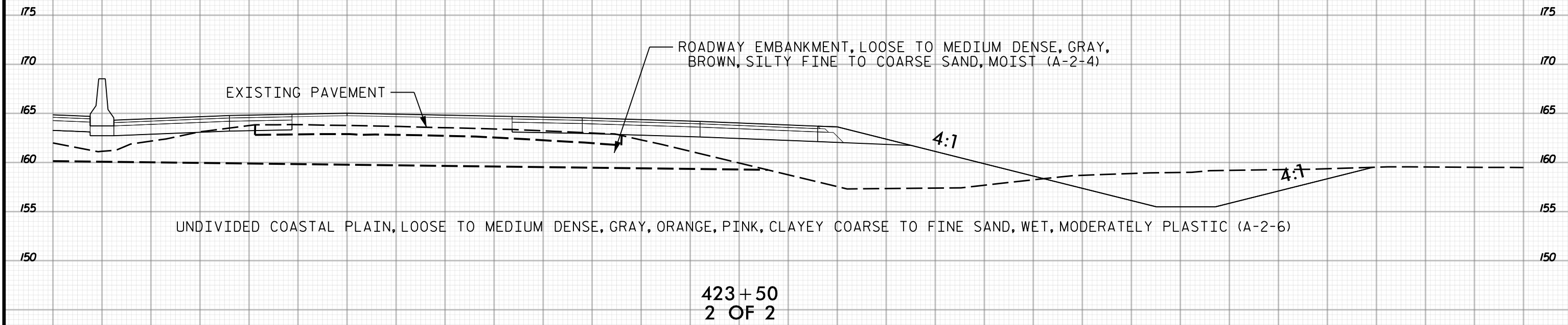
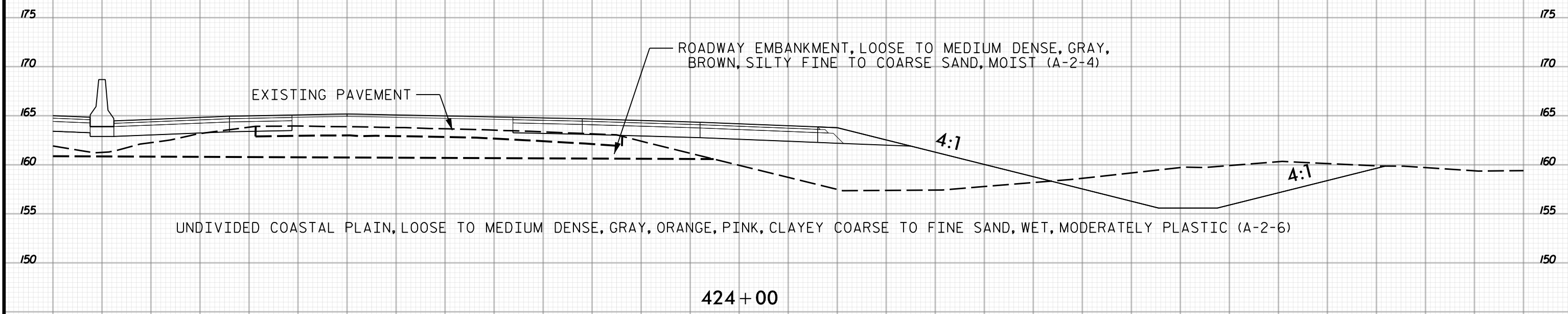

5 0 5 10 15 20 25 30 35 40 45 50 55 60 65 70 75 80 85 90 95 100 105 110 115 120 125 130 135 140 145

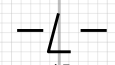

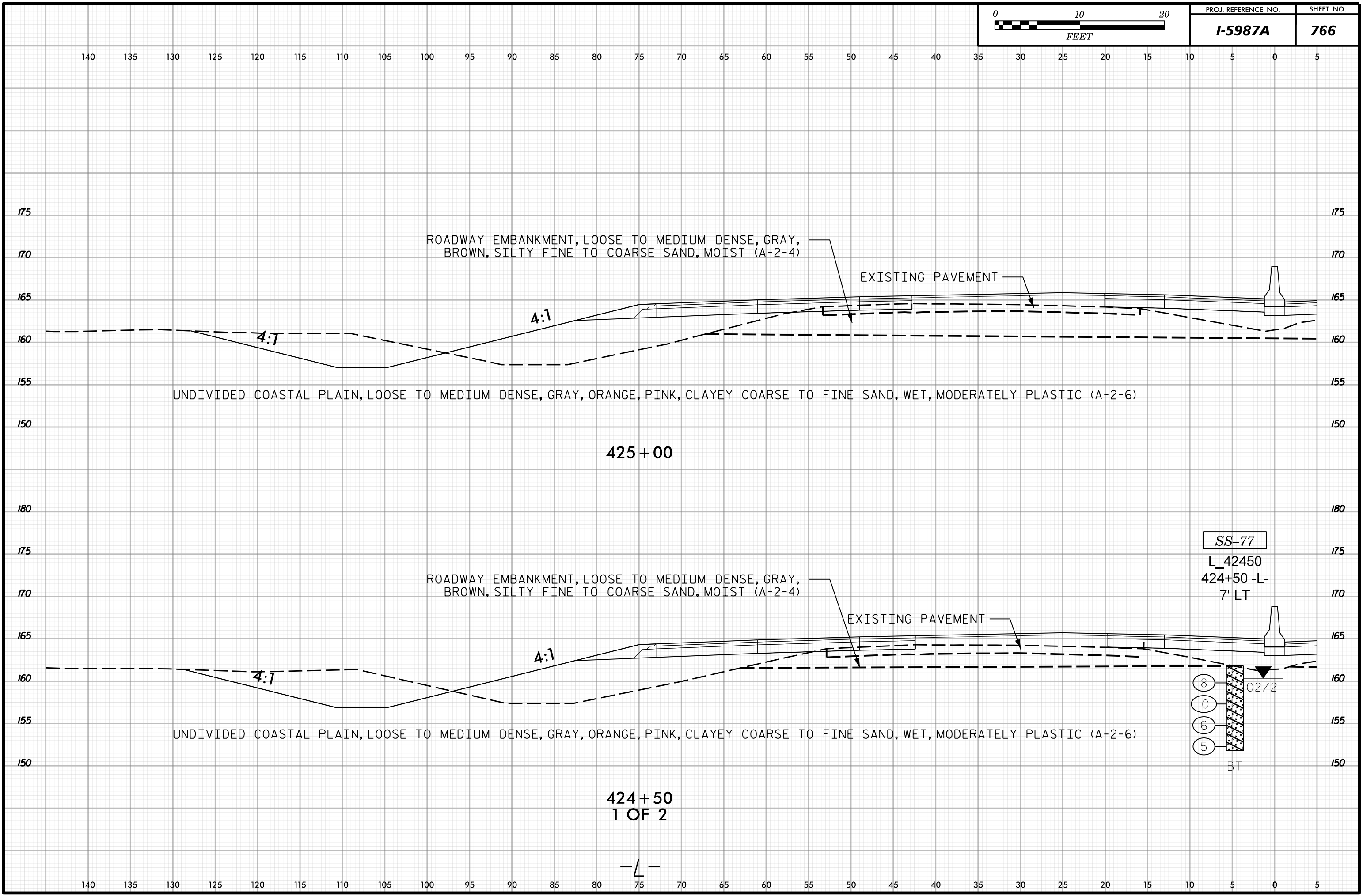

140 135 130 125 120 115 110 105 100 95 90 85 80 75 70 65 60 55 50 45 40 35 30 25 20 15 10 5 0 5

175 175

170 170

165 165

160 160

155 155

150 150

180 180

175 175

170 170

165 165

160 160

155 155

150 150

ROADWAY EMBANKMENT, LOOSE TO MEDIUM DENSE, GRAY, BROWN, SILTY FINE TO COARSE SAND, MOIST (A-2-4)

EXISTING PAVEMENT

4:1

4:1

UNDIVIDED COASTAL PLAIN, LOOSE TO MEDIUM DENSE, GRAY, ORANGE, PINK, CLAYEY COARSE TO FINE SAND, WET, MODERATELY PLASTIC (A-2-6)

425+00

ROADWAY EMBANKMENT, LOOSE TO MEDIUM DENSE, GRAY, BROWN, SILTY FINE TO COARSE SAND, MOIST (A-2-4)

EXISTING PAVEMENT

4:1

4:1

UNDIVIDED COASTAL PLAIN, LOOSE TO MEDIUM DENSE, GRAY, ORANGE, PINK, CLAYEY COARSE TO FINE SAND, WET, MODERATELY PLASTIC (A-2-6)

424+50
1 OF 2

SS-77

L_42450
424+50 -L-
7' LT

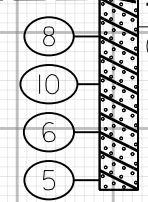

02/21

-L-

140 135 130 125 120 115 110 105 100 95 90 85 80 75 70 65 60 55 50 45 40 35 30 25 20 15 10 5 0 5

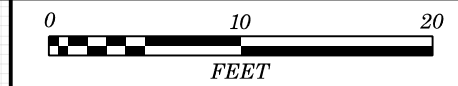

5 0 5 10 15 20 25 30 35 40 45 50 55 60 65 70 75 80 85 90 95 100 105 110 115 120 125 130 135 140 145

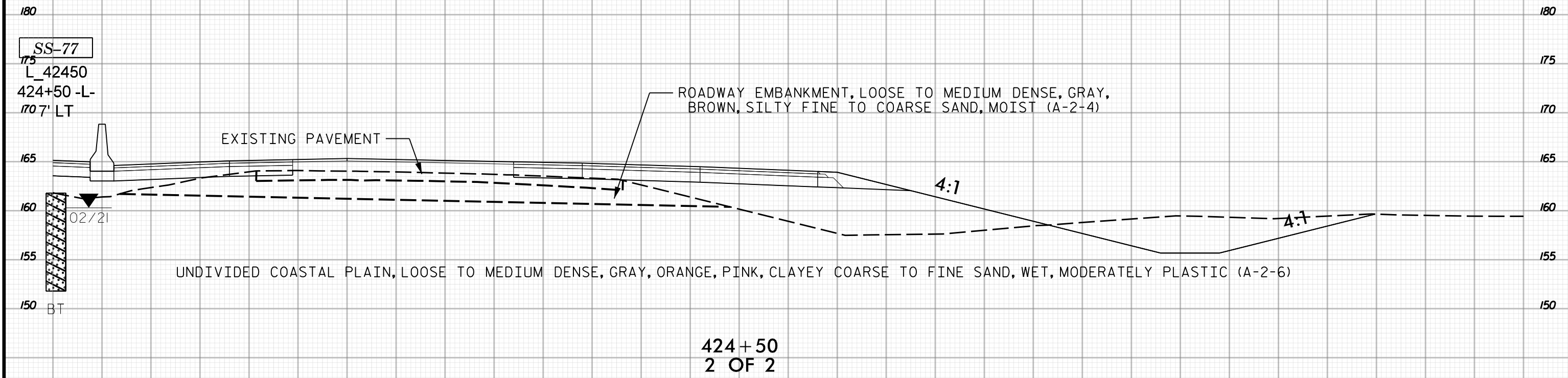
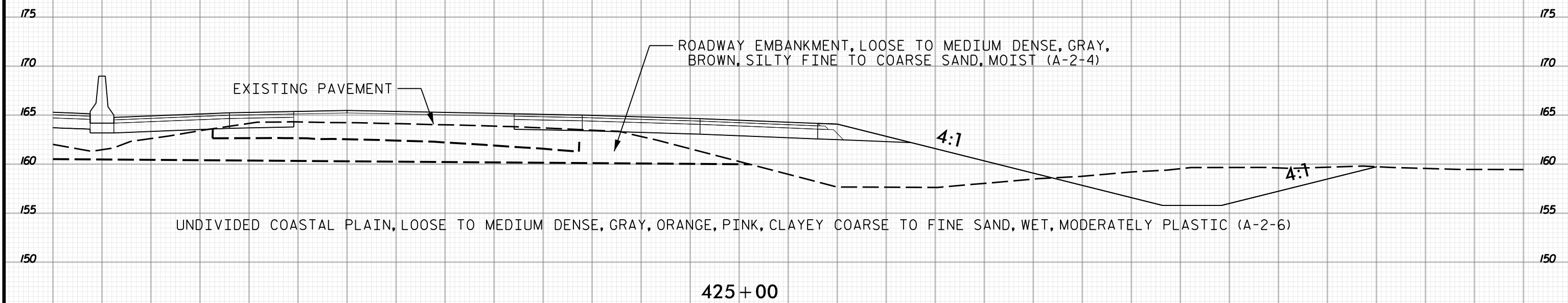

5 0 5 10 15 20 25 30 35 40 45 50 55 60 65 70 75 80 85 90 95 100 105 110 115 120 125 130 135 140 145



140 135 130 125 120 115 110 105 100 95 90 85 80 75 70 65 60 55 50 45 40 35 30 25 20 15 10 5 0 5

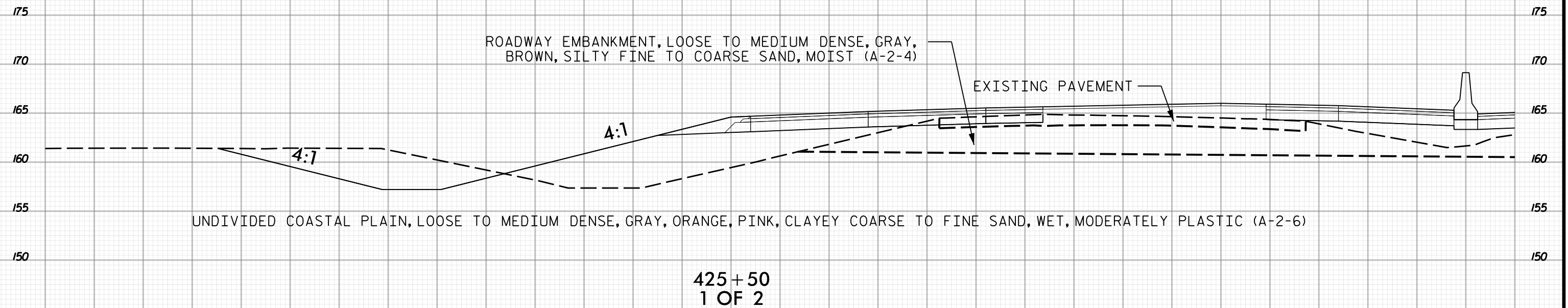
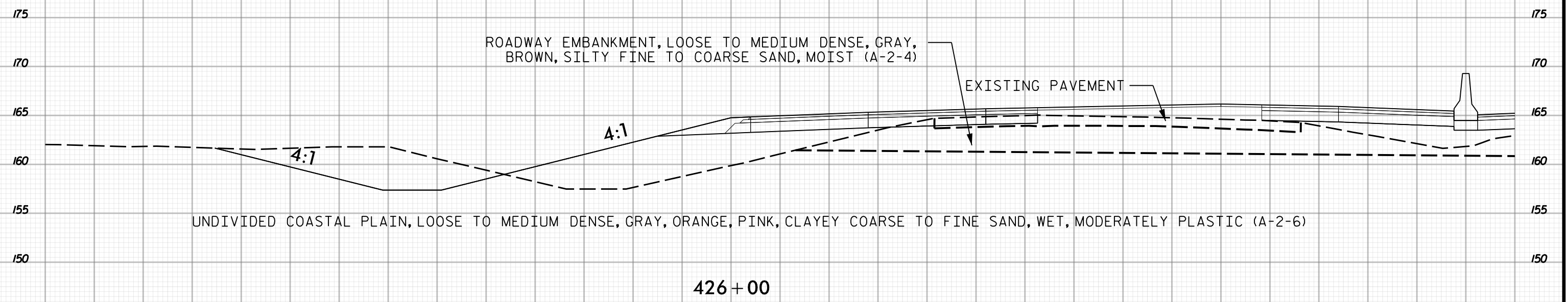

140 135 130 125 120 115 110 105 100 95 90 85 80 75 70 65 60 55 50 45 40 35 30 25 20 15 10 5 0 5

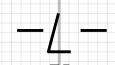



PROJ. REFERENCE NO.	SHEET NO.
I-5987A	769

5 0 5 10 15 20 25 30 35 40 45 50 55 60 65 70 75 80 85 90 95 100 105 110 115 120 125 130 135 140 145

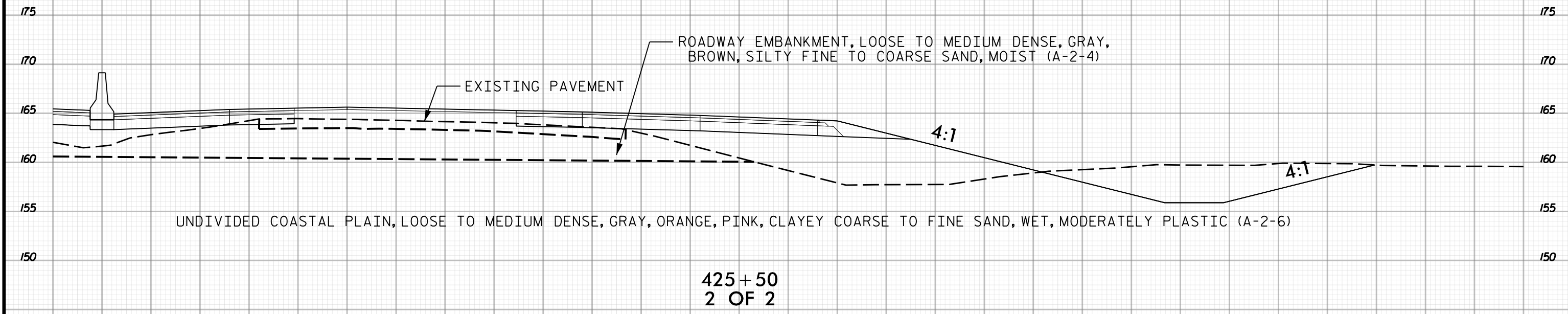
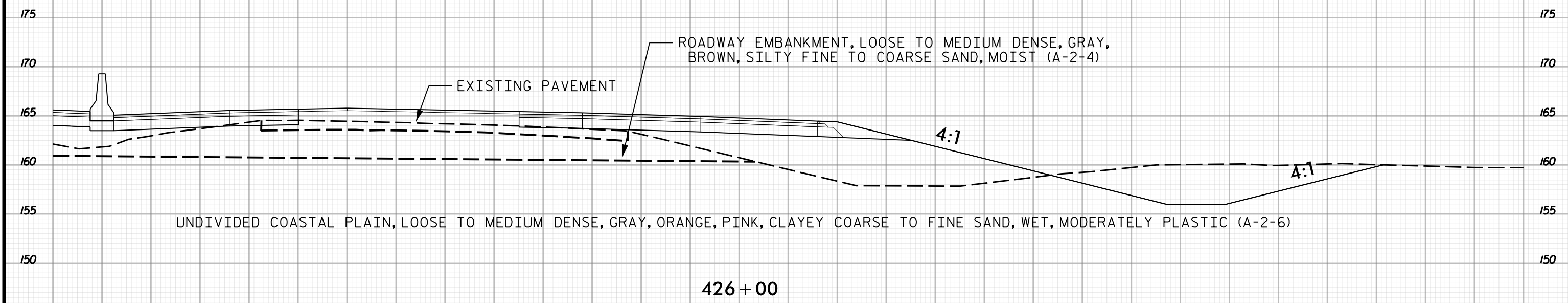

5 0 5 10 15 20 25 30 35 40 45 50 55 60 65 70 75 80 85 90 95 100 105 110 115 120 125 130 135 140 145

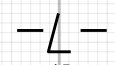

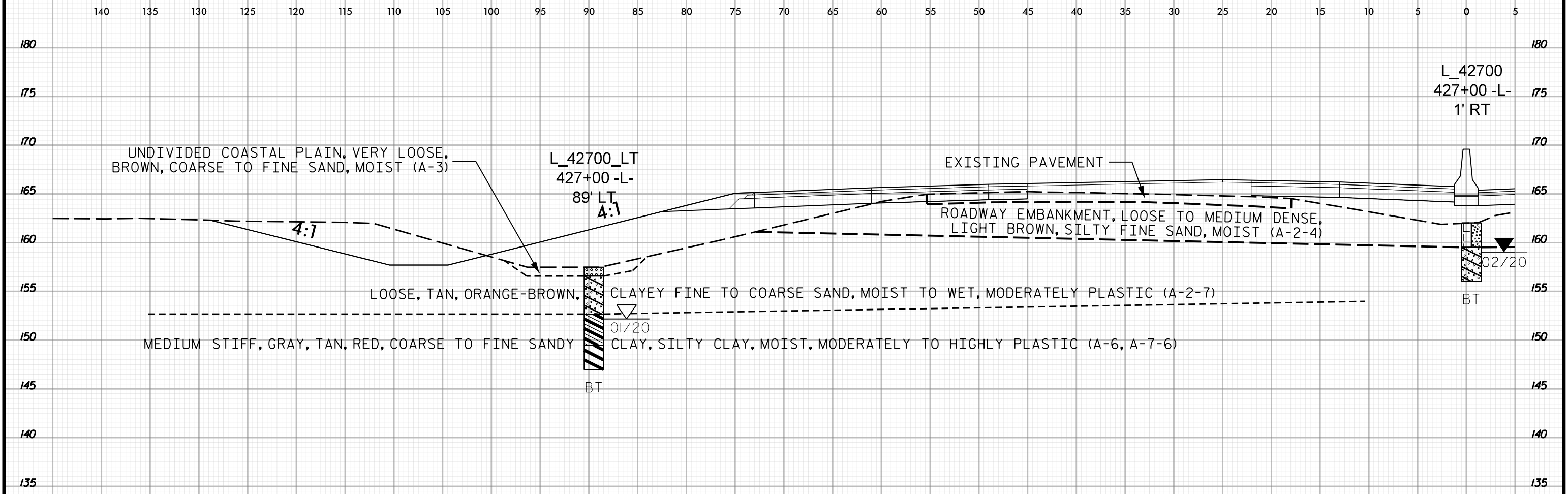

427+00

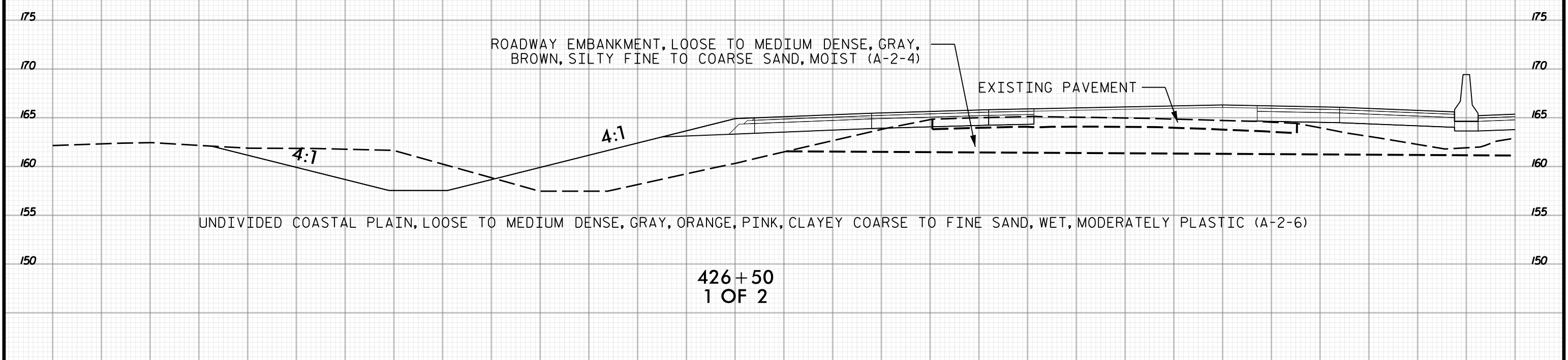

426+50
1 OF 2

-L-

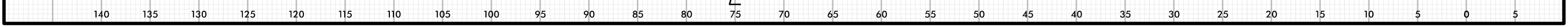

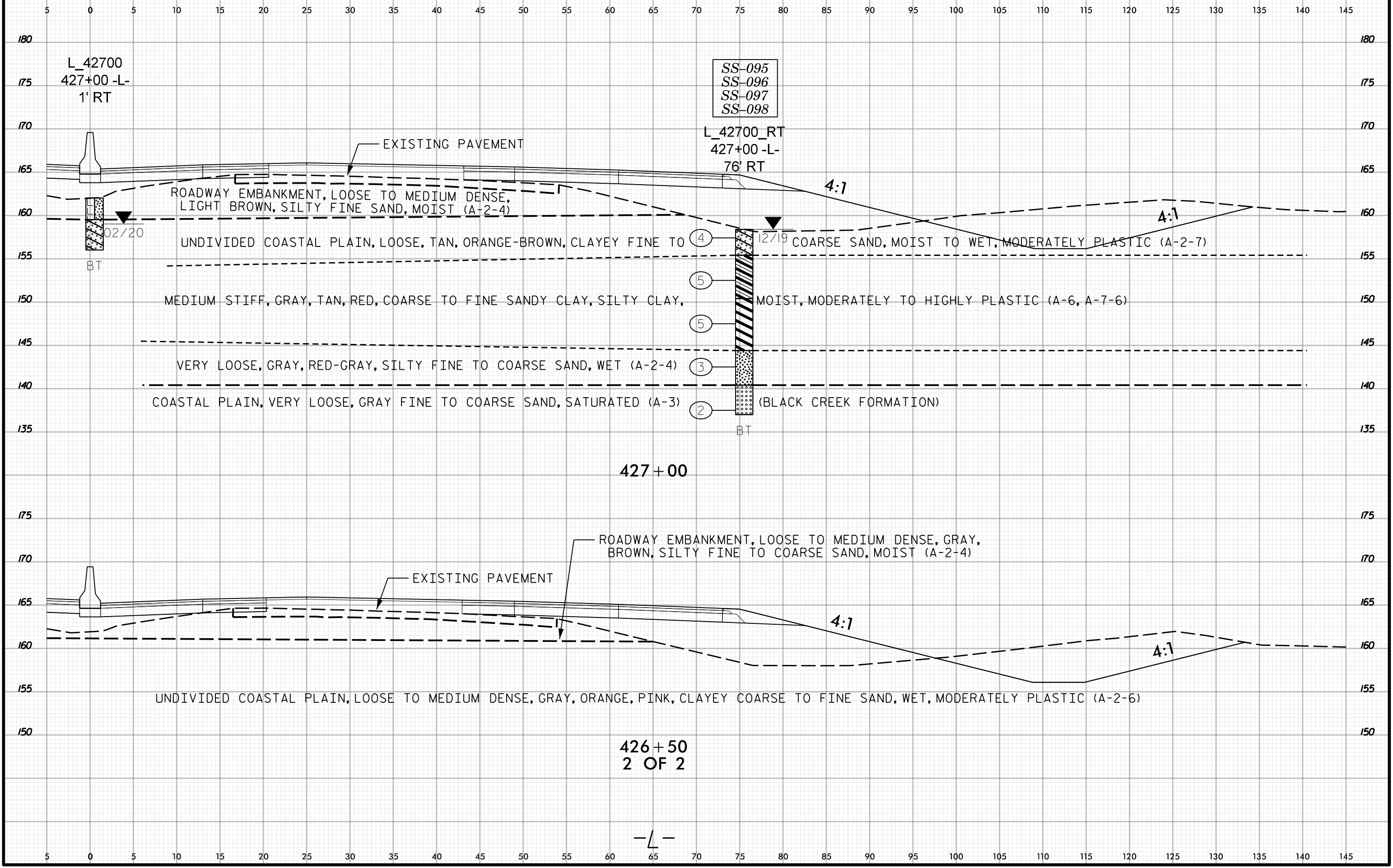

427+00

426+50
2 OF 2

-L-

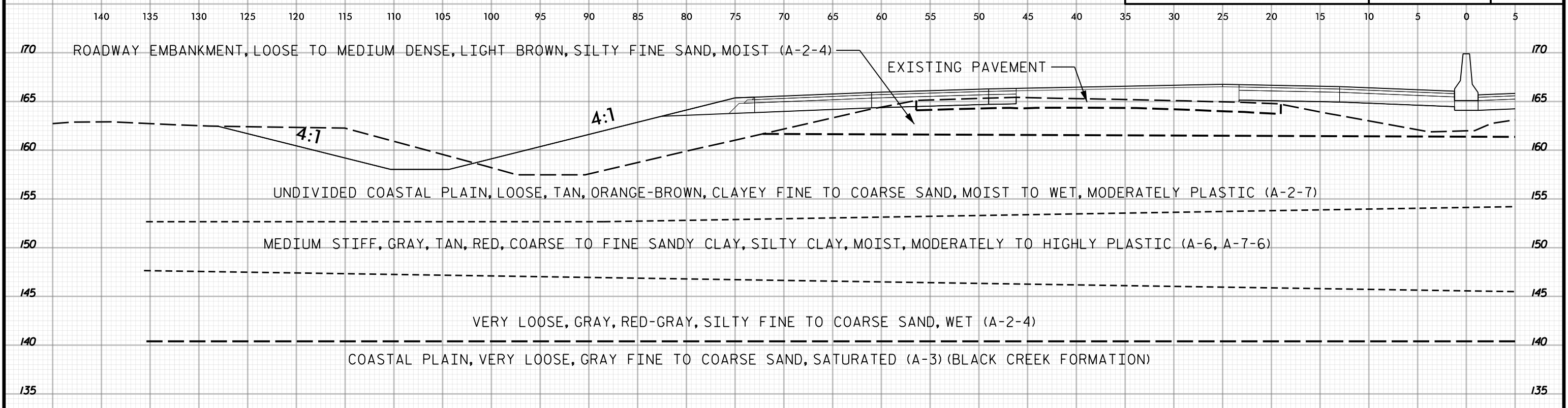

428+00

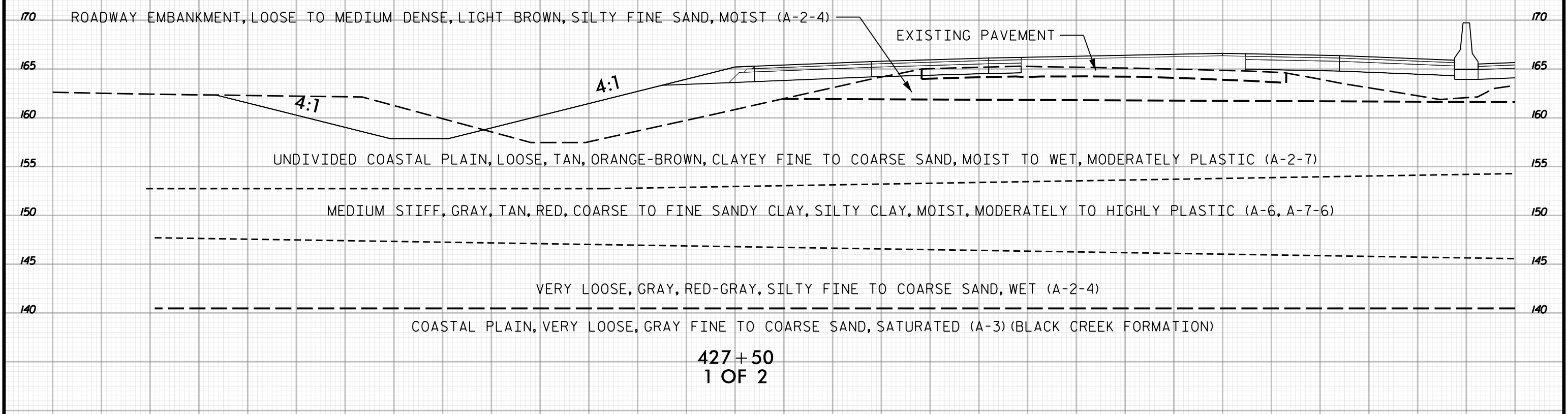

427+50
1 OF 2

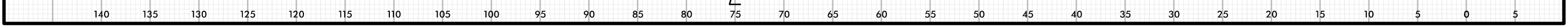
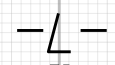

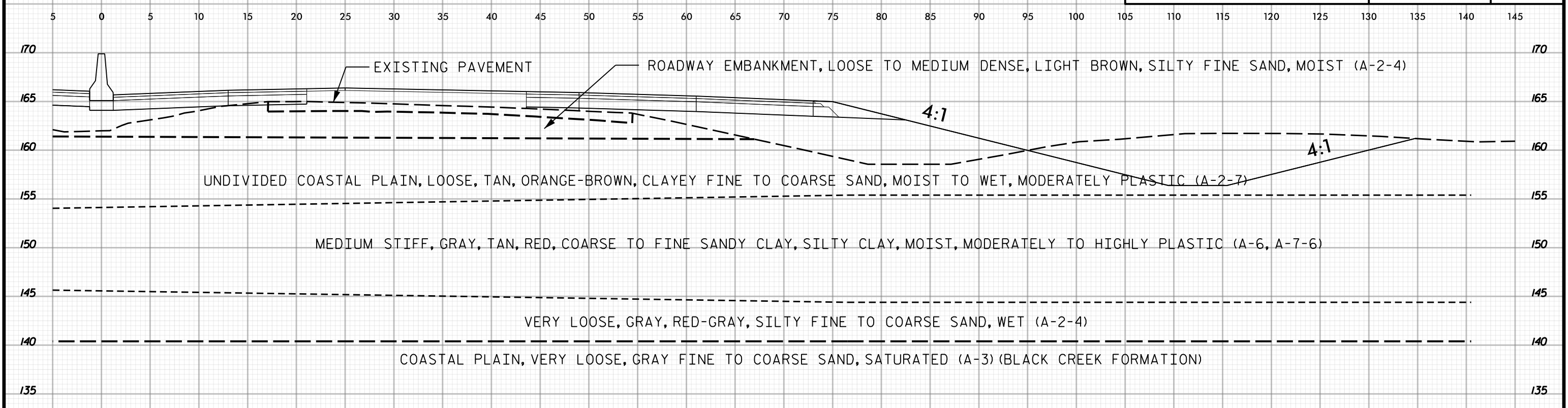

428+00

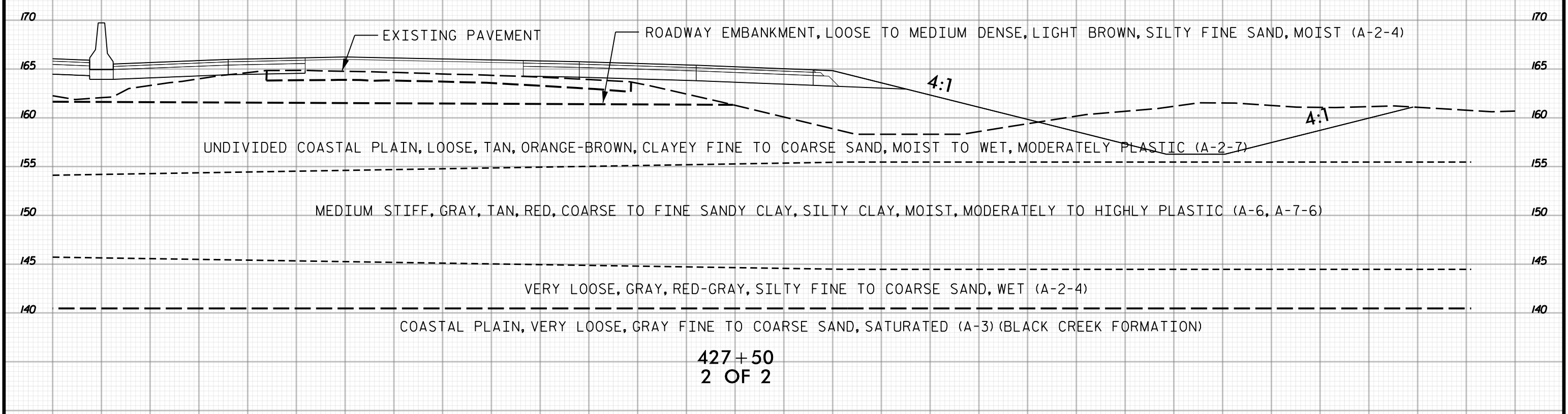

427+50
2 OF 2

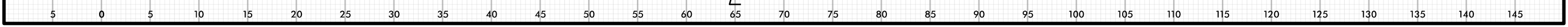
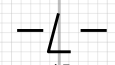



140 135 130 125 120 115 110 105 100 95 90 85 80 75 70 65 60 55 50 45 40 35 30 25 20 15 10 5 0 5

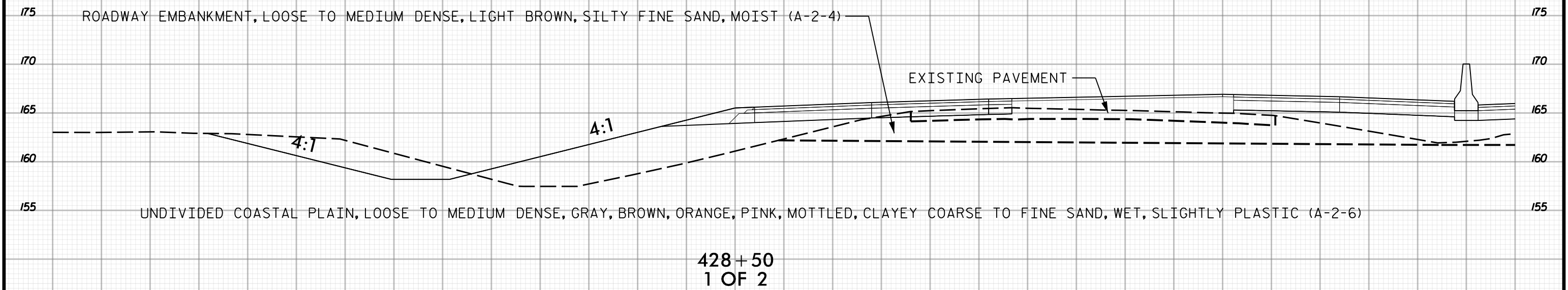
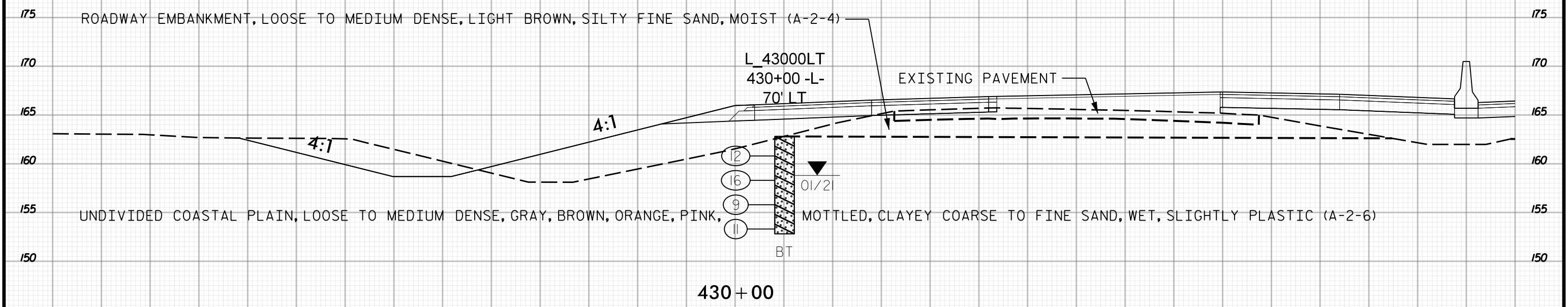

140 135 130 125 120 115 110 105 100 95 90 85 80 75 70 65 60 55 50 45 40 35 30 25 20 15 10 5 0 5



PROJ. REFERENCE NO.	SHEET NO.
I-5987A	775

5 0 5 10 15 20 25 30 35 40 45 50 55 60 65 70 75 80 85 90 95 100 105 110 115 120 125 130 135 140 145

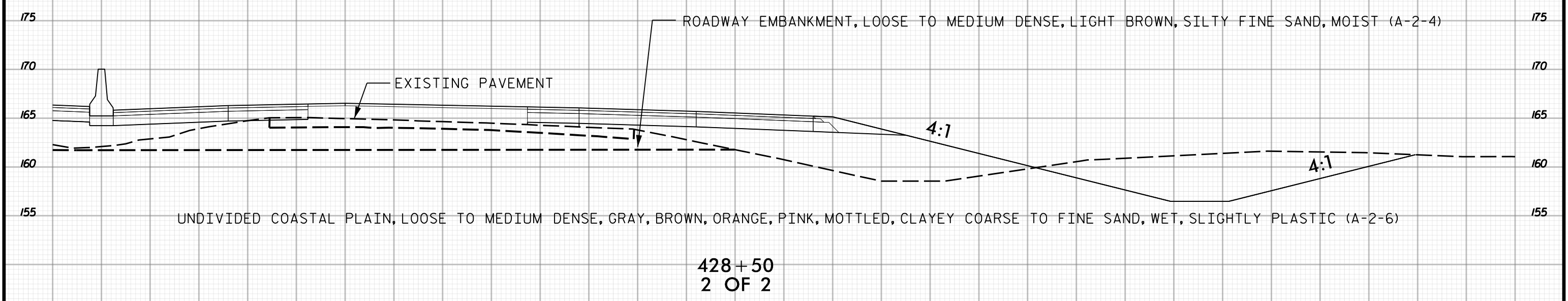
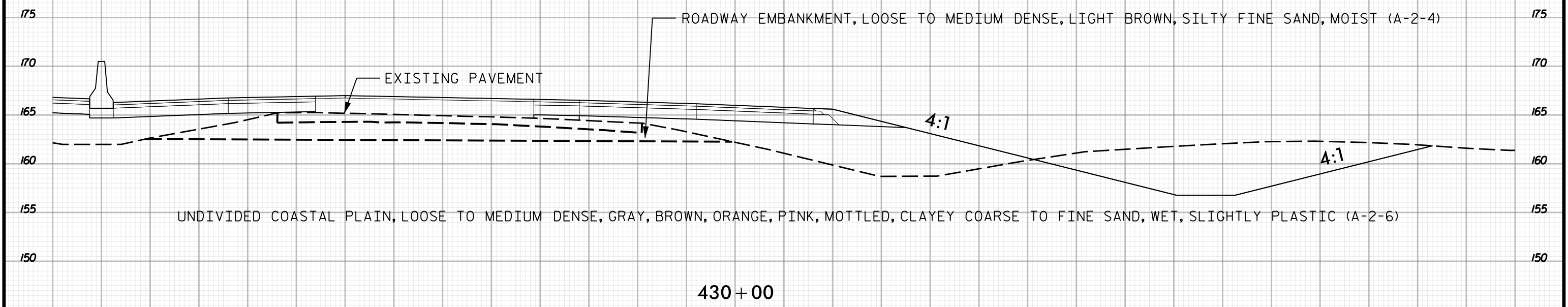

5 0 5 10 15 20 25 30 35 40 45 50 55 60 65 70 75 80 85 90 95 100 105 110 115 120 125 130 135 140 145

-L-



PROJ. REFERENCE NO.	SHEET NO.
I-5987A	776

140 135 130 125 120 115 110 105 100 95 90 85 80 75 70 65 60 55 50 45 40 35 30 25 20 15 10 5 0 5

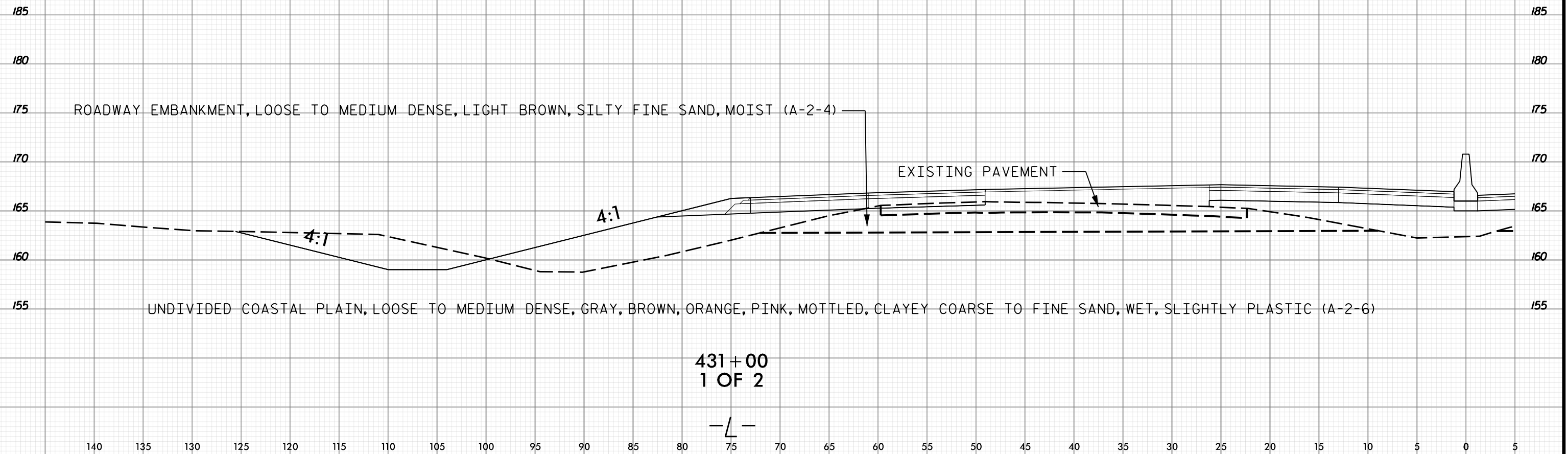

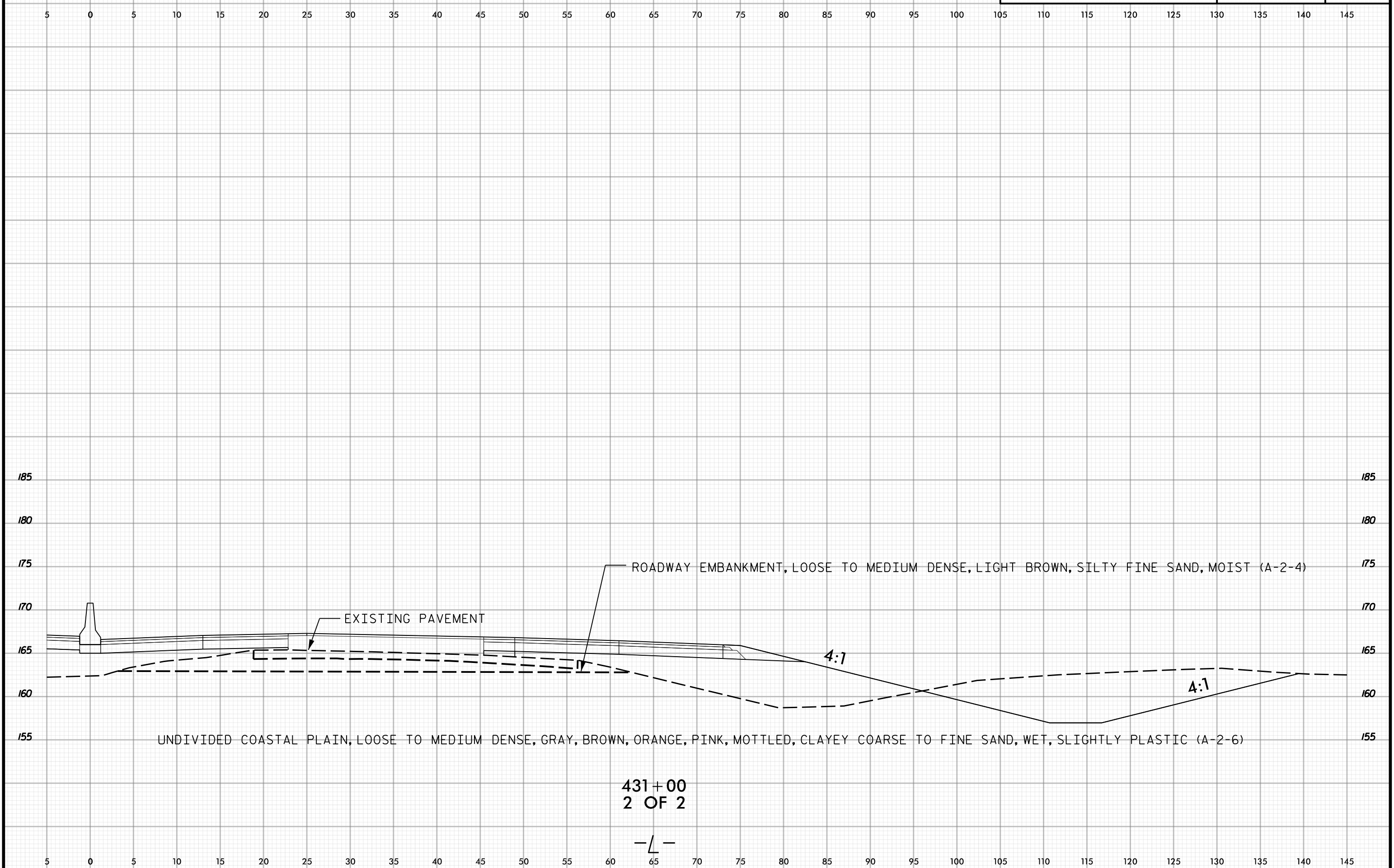

431+00
2 OF 2

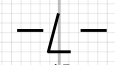



140 135 130 125 120 115 110 105 100 95 90 85 80 75 70 65 60 55 50 45 40 35 30 25 20 15 10 5 0 5

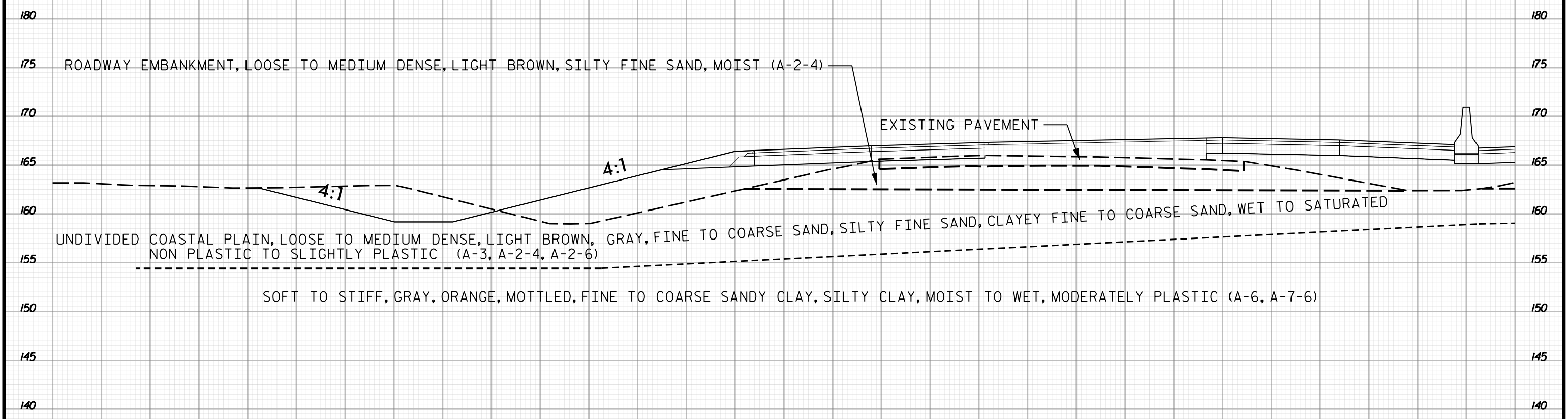

431+50
1 OF 2

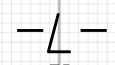

140 135 130 125 120 115 110 105 100 95 90 85 80 75 70 65 60 55 50 45 40 35 30 25 20 15 10 5 0 5

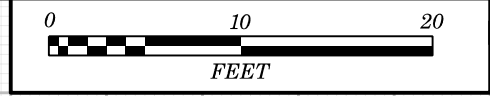

PROJ. REFERENCE NO.	SHEET NO.
I-5987A	779

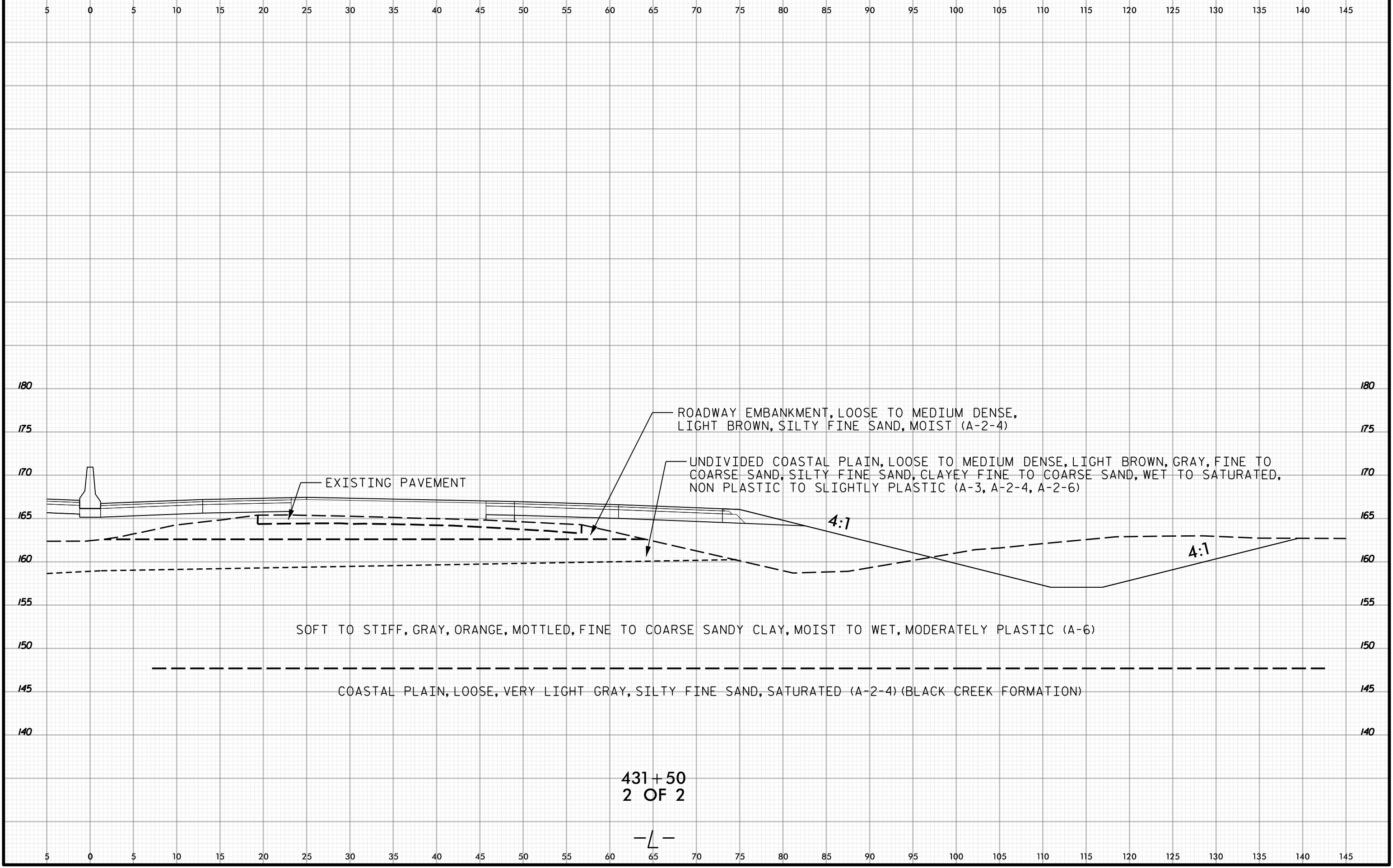

EXISTING PAVEMENT

ROADWAY EMBANKMENT, LOOSE TO MEDIUM DENSE, LIGHT BROWN, SILTY FINE SAND, MOIST (A-2-4)

UNDIVIDED COASTAL PLAIN, LOOSE TO MEDIUM DENSE, LIGHT BROWN, GRAY, FINE TO COARSE SAND, SILTY FINE SAND, CLAYEY FINE TO COARSE SAND, WET TO SATURATED, NON PLASTIC TO SLIGHTLY PLASTIC (A-3, A-2-4, A-2-6)

SOFT TO STIFF, GRAY, ORANGE, MOTTLED, FINE TO COARSE SANDY CLAY, MOIST TO WET, MODERATELY PLASTIC (A-6)

COASTAL PLAIN, LOOSE, VERY LIGHT GRAY, SILTY FINE SAND, SATURATED (A-2-4) (BLACK CREEK FORMATION)

431+50
2 OF 2

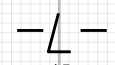



140 135 130 125 120 115 110 105 100 95 90 85 80 75 70 65 60 55 50 45 40 35 30 25 20 15 10 5 0 5

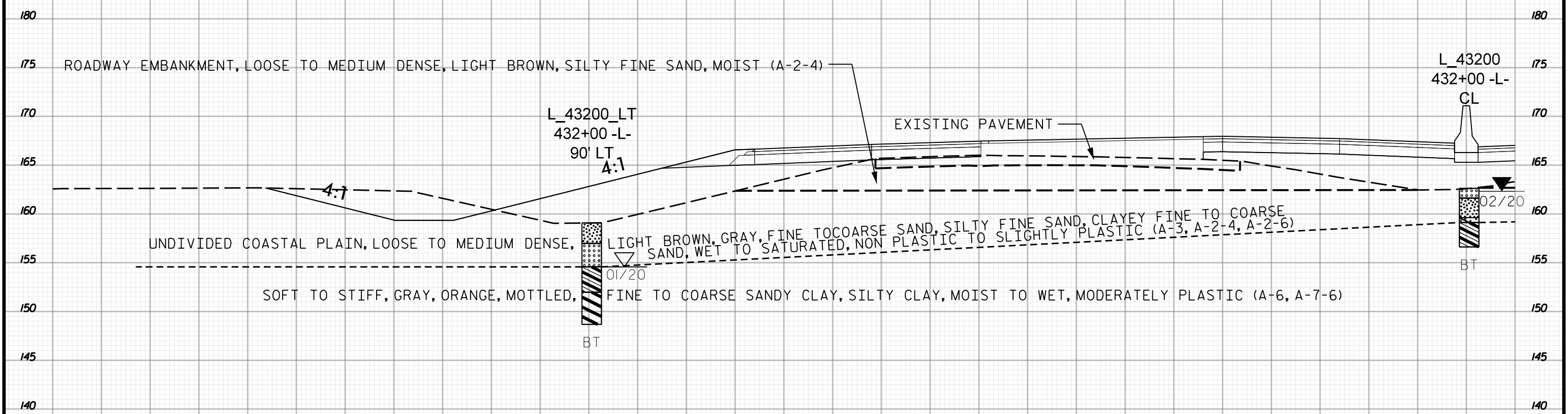

432 + 00
1 OF 2

-L-

140 135 130 125 120 115 110 105 100 95 90 85 80 75 70 65 60 55 50 45 40 35 30 25 20 15 10 5 0 5

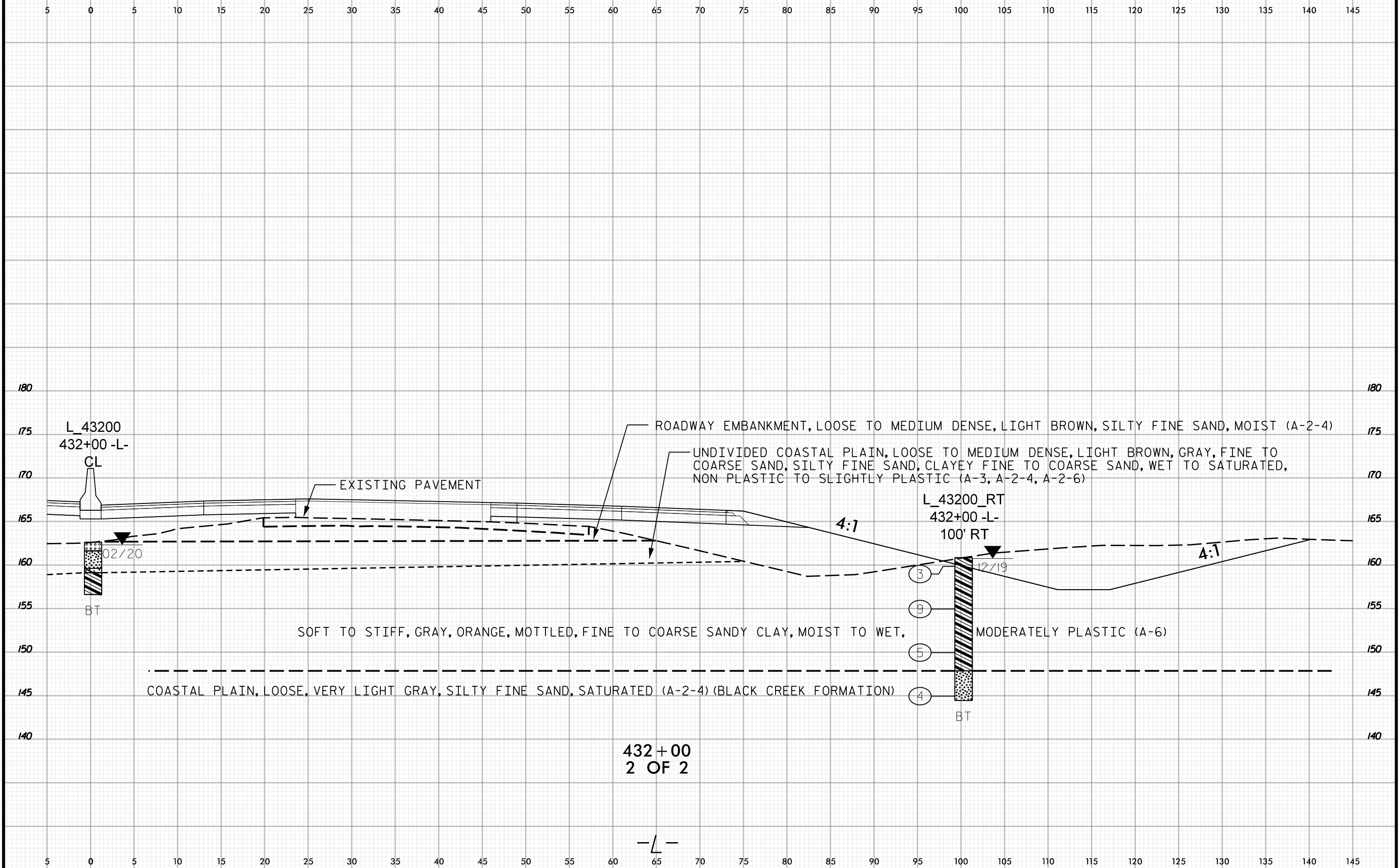

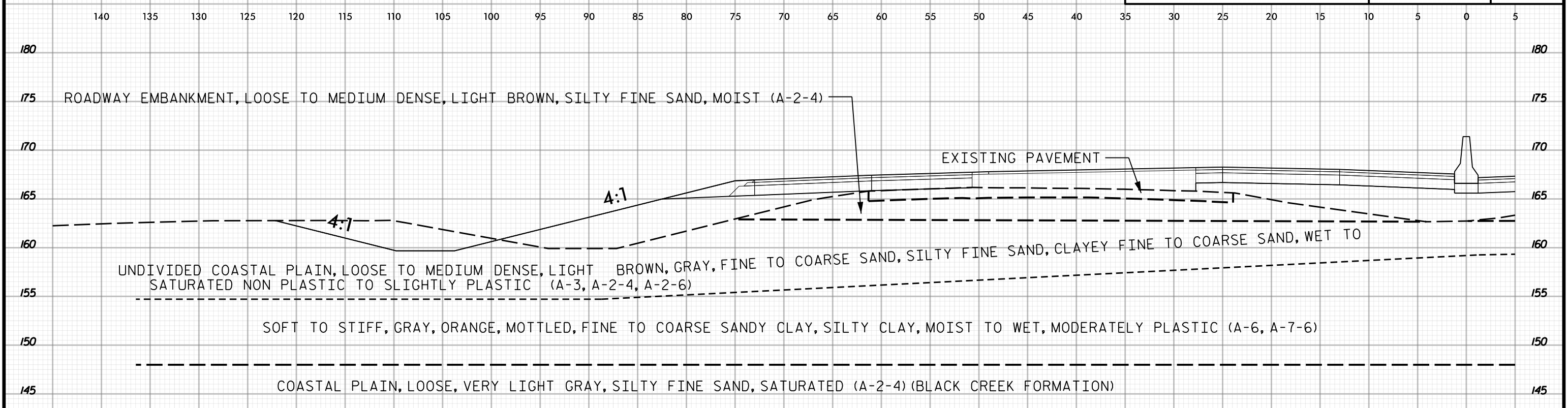

433+00

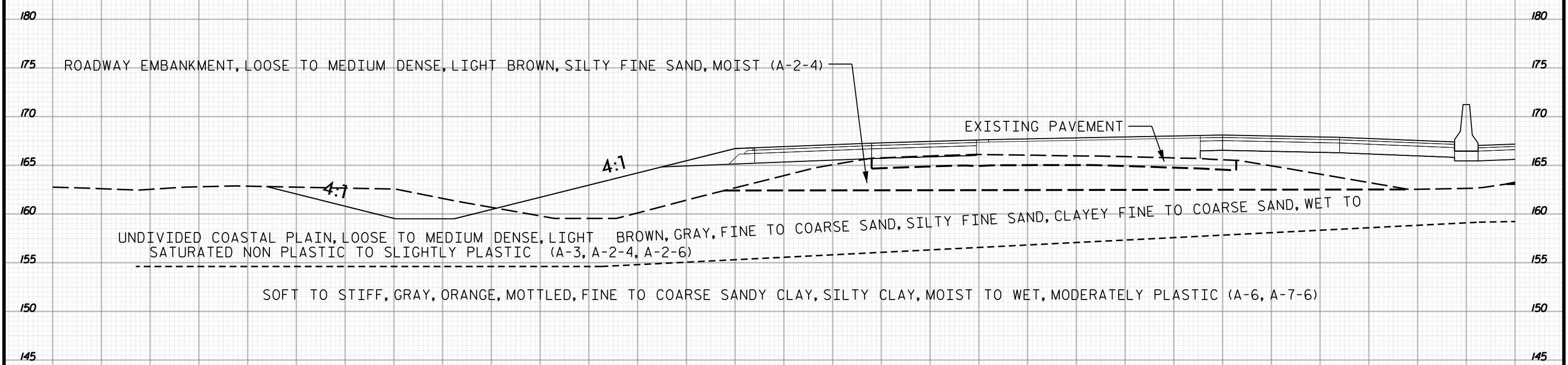

432+50
1 OF 2

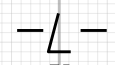

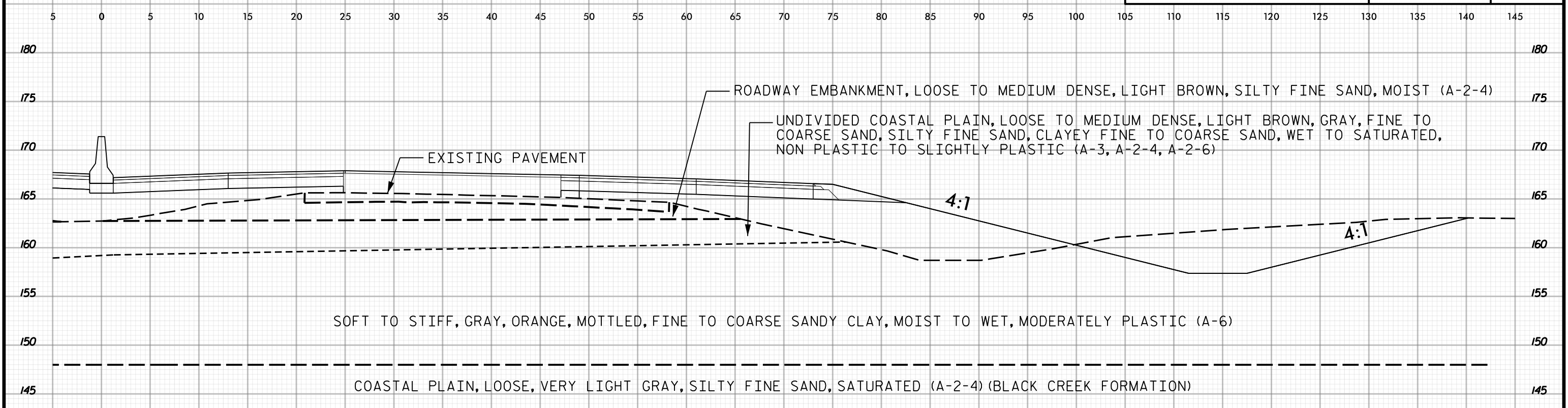

433+00

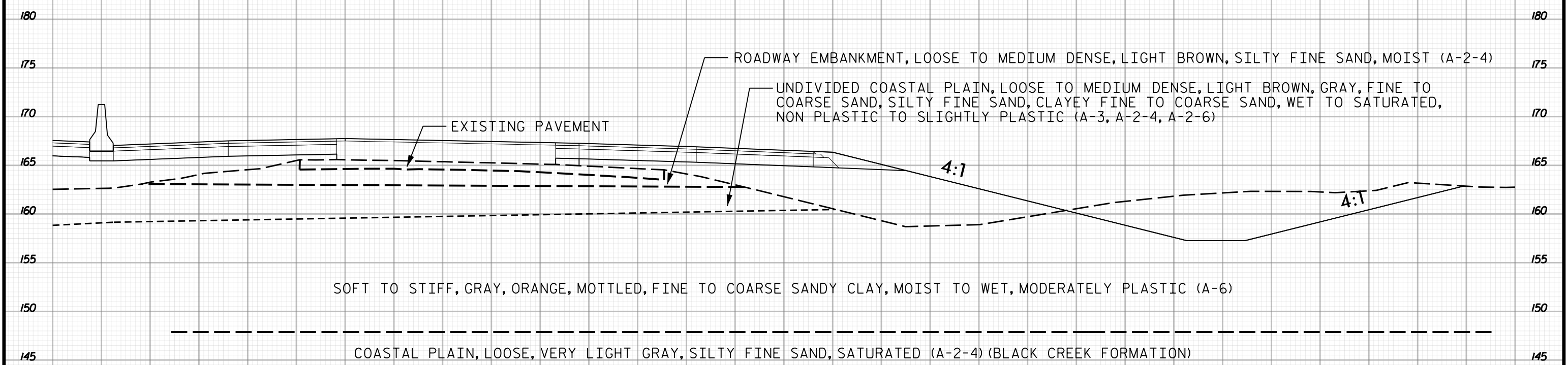

432+50
2 OF 2

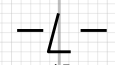



140 135 130 125 120 115 110 105 100 95 90 85 80 75 70 65 60 55 50 45 40 35 30 25 20 15 10 5 0 5

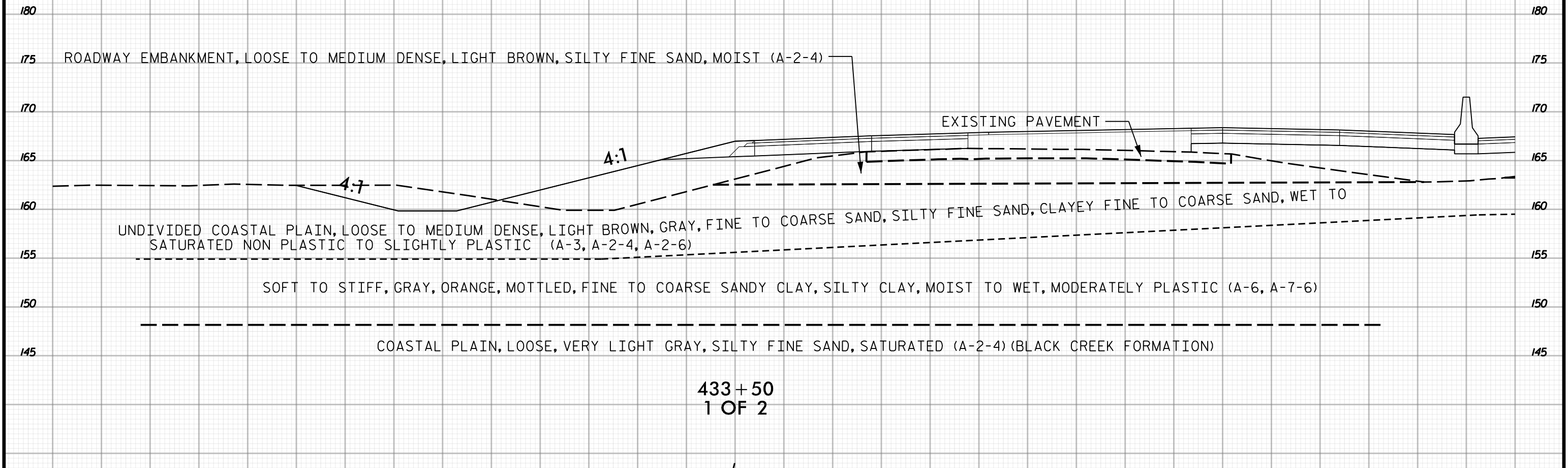
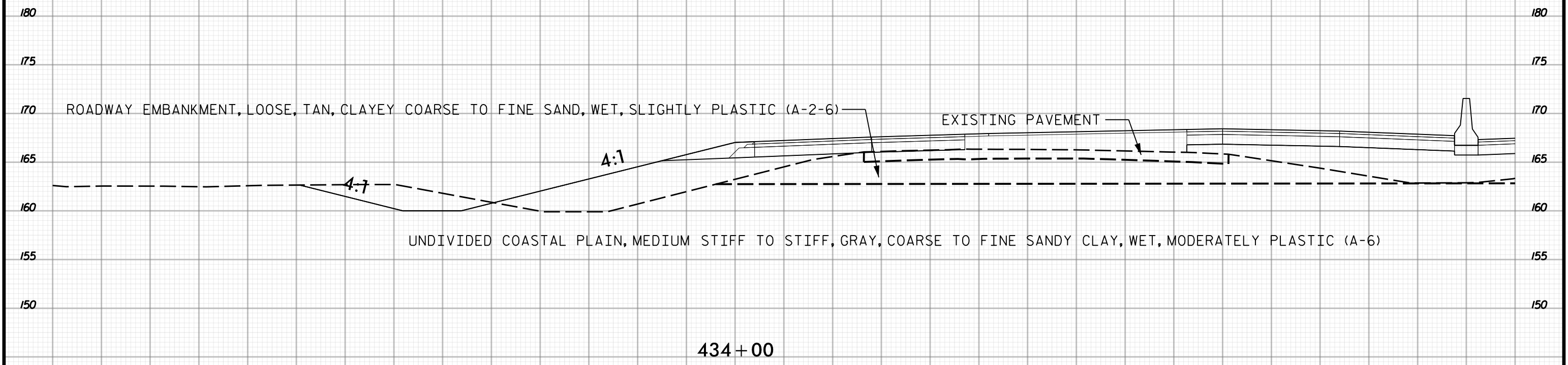

140 135 130 125 120 115 110 105 100 95 90 85 80 75 70 65 60 55 50 45 40 35 30 25 20 15 10 5 0 5



5 0 5 10 15 20 25 30 35 40 45 50 55 60 65 70 75 80 85 90 95 100 105 110 115 120 125 130 135 140 145

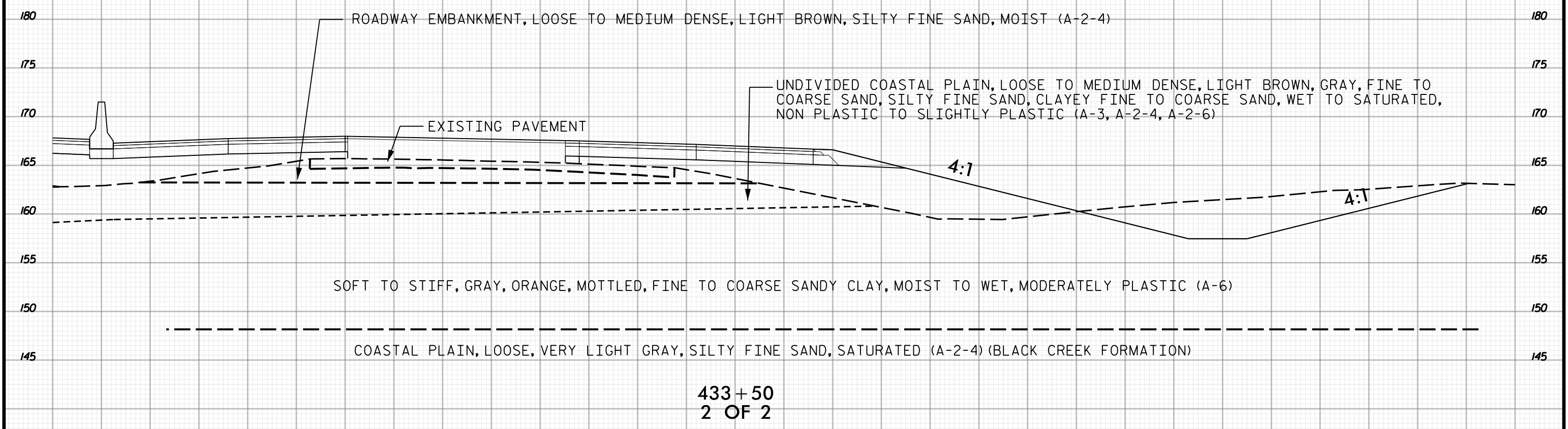
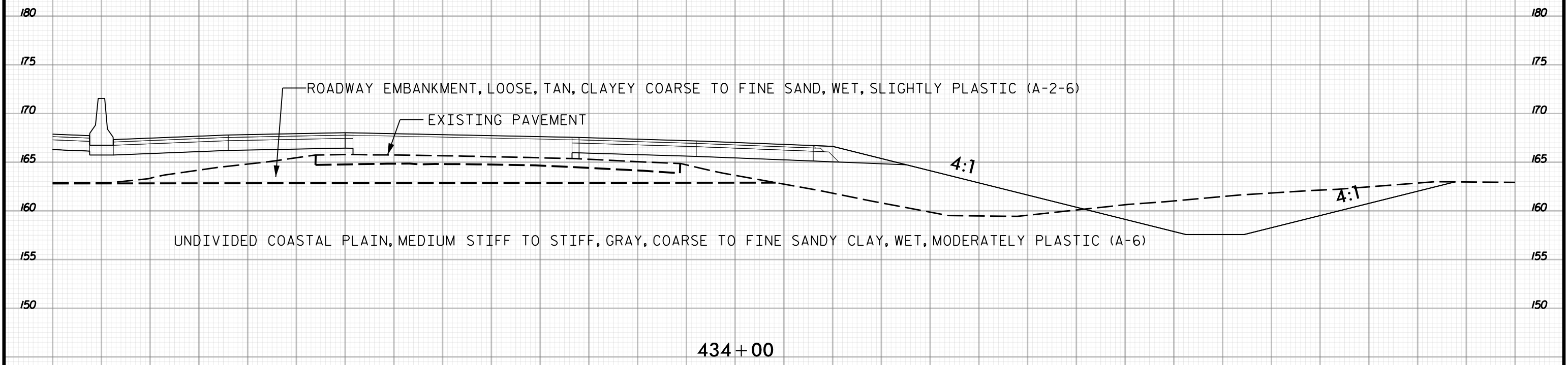

5 0 5 10 15 20 25 30 35 40 45 50 55 60 65 70 75 80 85 90 95 100 105 110 115 120 125 130 135 140 145



140 135 130 125 120 115 110 105 100 95 90 85 80 75 70 65 60 55 50 45 40 35 30 25 20 15 10 5 0 5

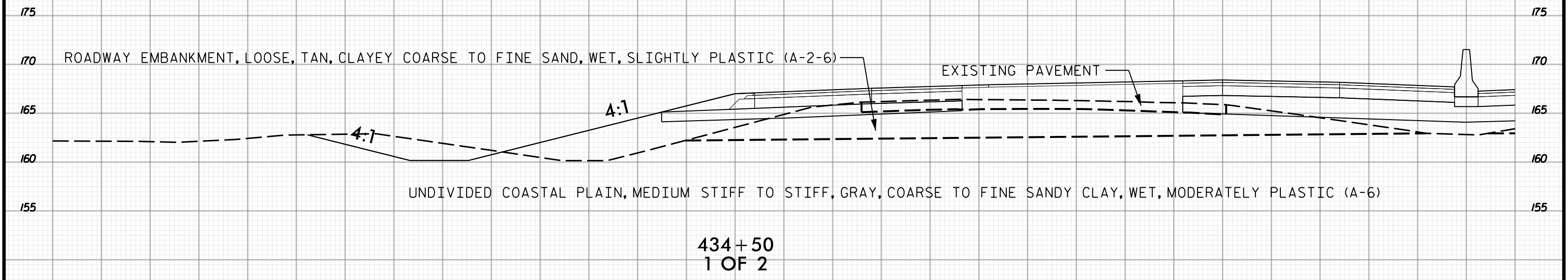
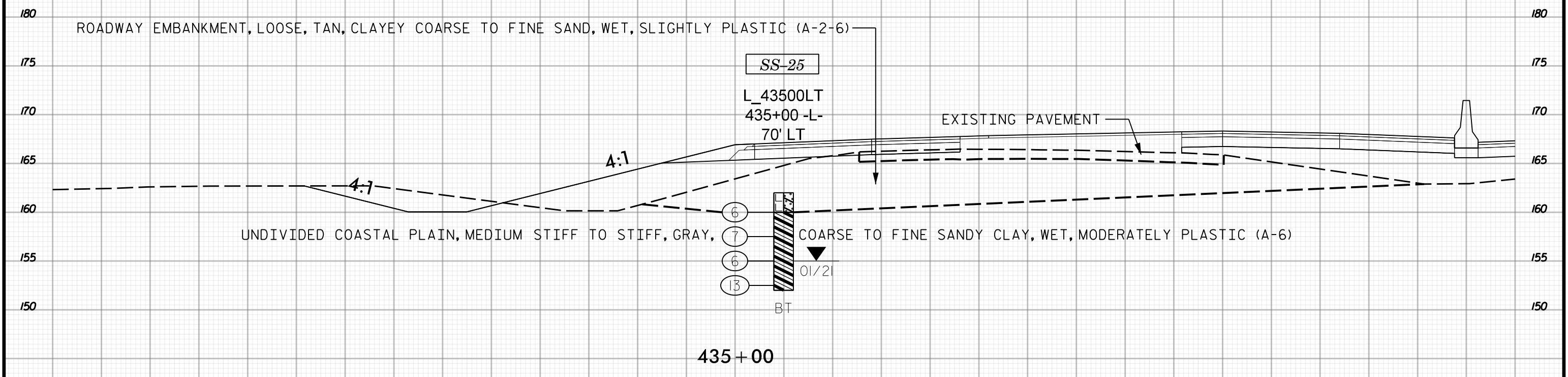

140 135 130 125 120 115 110 105 100 95 90 85 80 75 70 65 60 55 50 45 40 35 30 25 20 15 10 5 0 5



5 0 5 10 15 20 25 30 35 40 45 50 55 60 65 70 75 80 85 90 95 100 105 110 115 120 125 130 135 140 145

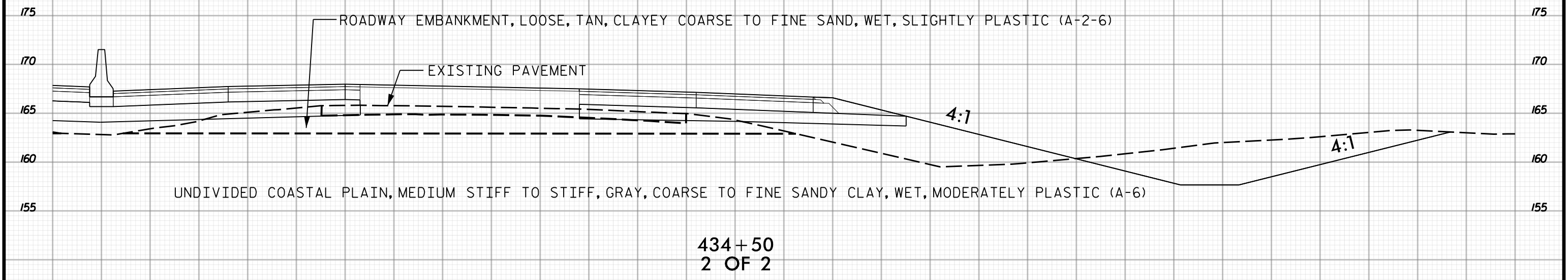
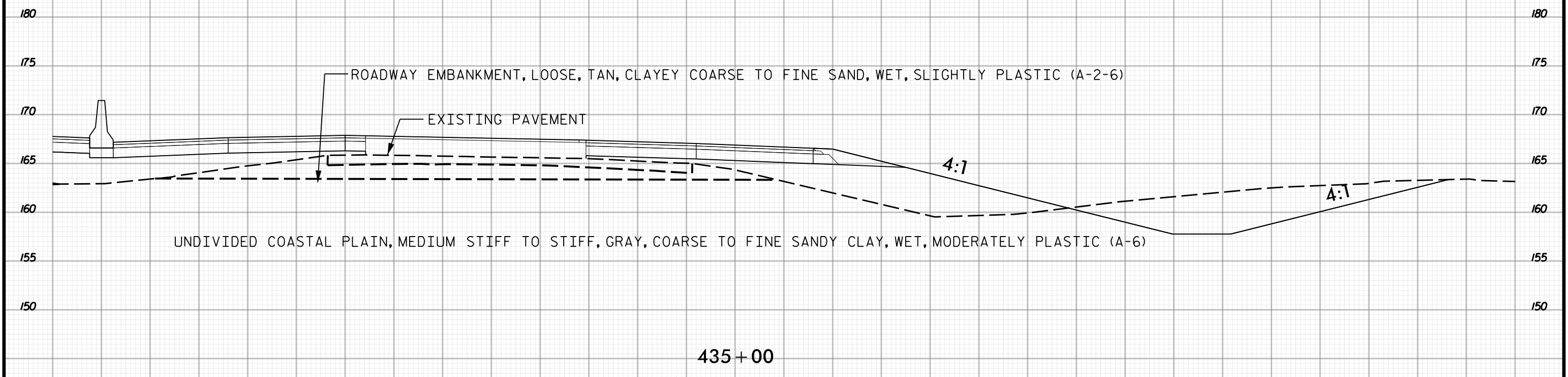

5 0 5 10 15 20 25 30 35 40 45 50 55 60 65 70 75 80 85 90 95 100 105 110 115 120 125 130 135 140 145



140 135 130 125 120 115 110 105 100 95 90 85 80 75 70 65 60 55 50 45 40 35 30 25 20 15 10 5 0 5

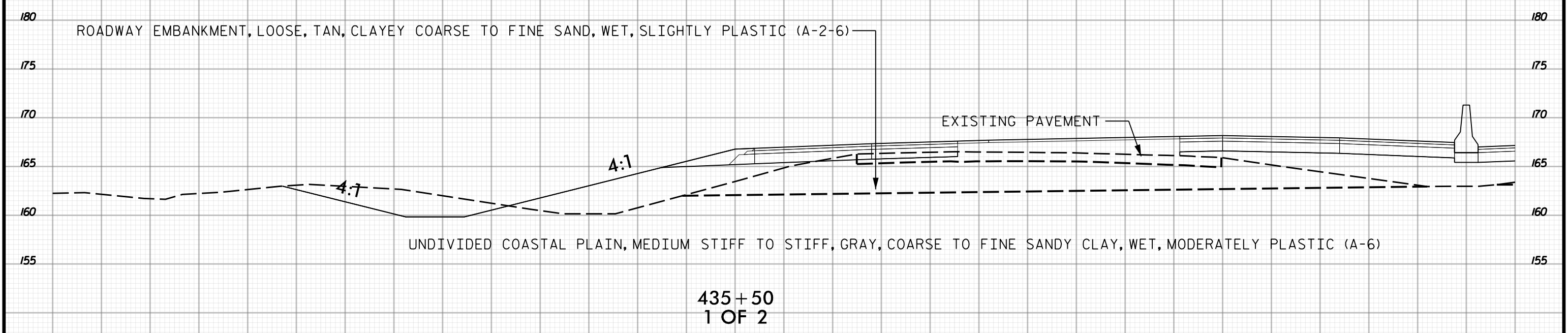
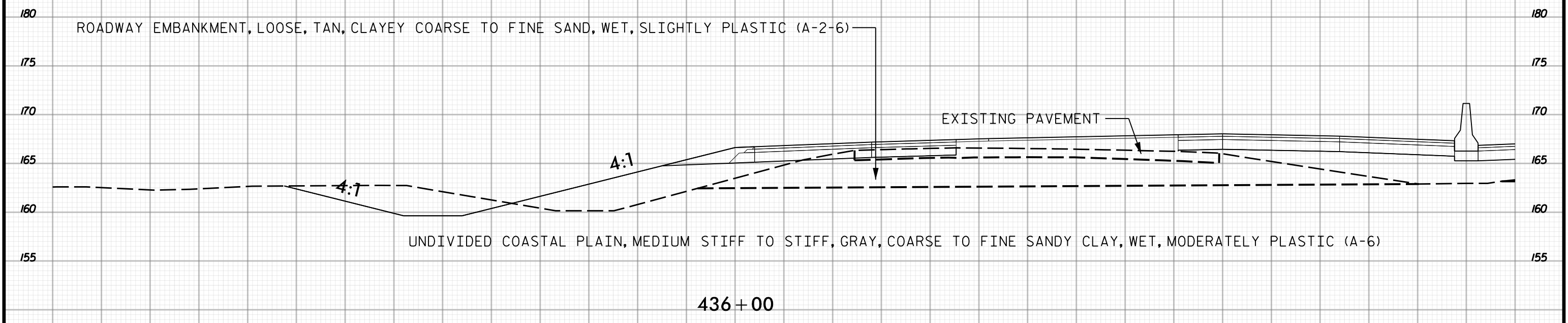

140 135 130 125 120 115 110 105 100 95 90 85 80 75 70 65 60 55 50 45 40 35 30 25 20 15 10 5 0 5



PROJ. REFERENCE NO.	SHEET NO.
I-5987A	789

5 0 5 10 15 20 25 30 35 40 45 50 55 60 65 70 75 80 85 90 95 100 105 110 115 120 125 130 135 140 145

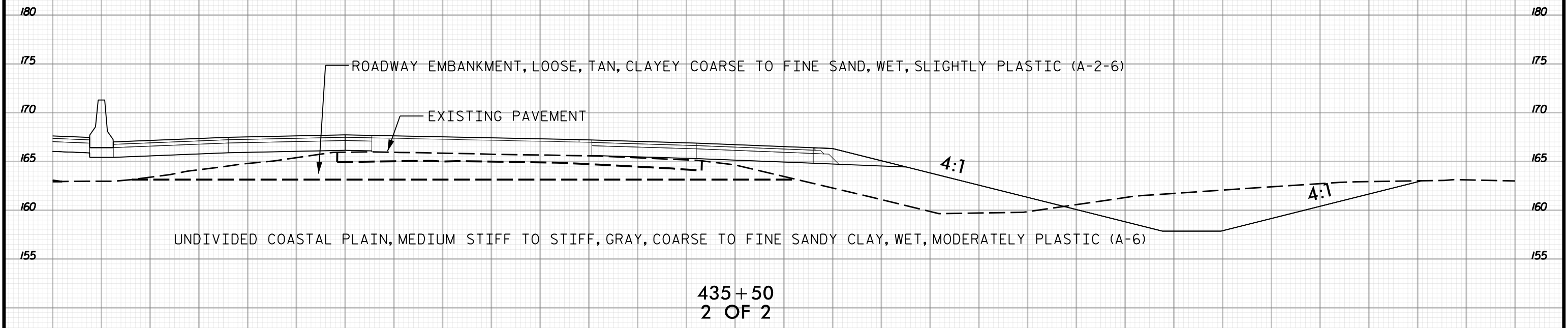
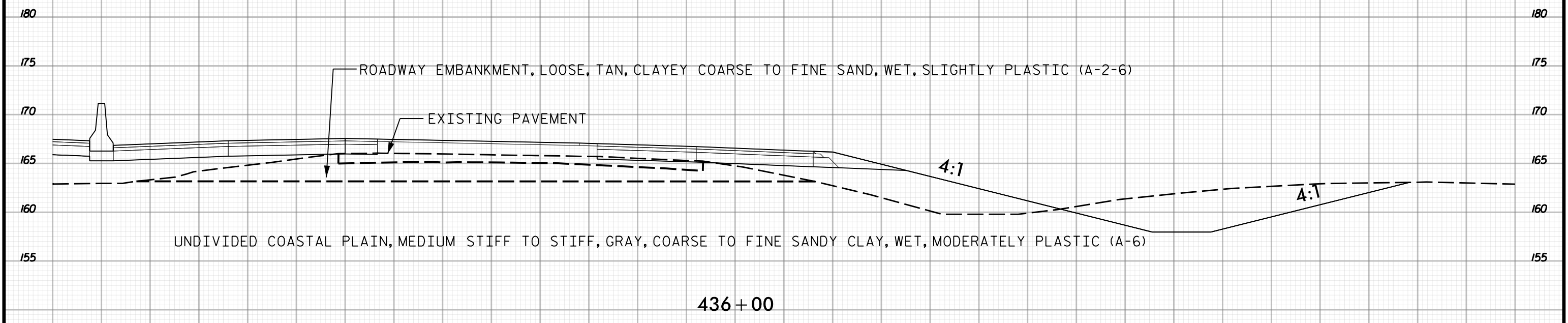

5 0 5 10 15 20 25 30 35 40 45 50 55 60 65 70 75 80 85 90 95 100 105 110 115 120 125 130 135 140 145

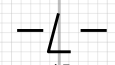



PROJ. REFERENCE NO.	SHEET NO.
I-5987A	790

140 135 130 125 120 115 110 105 100 95 90 85 80 75 70 65 60 55 50 45 40 35 30 25 20 15 10 5 0 5

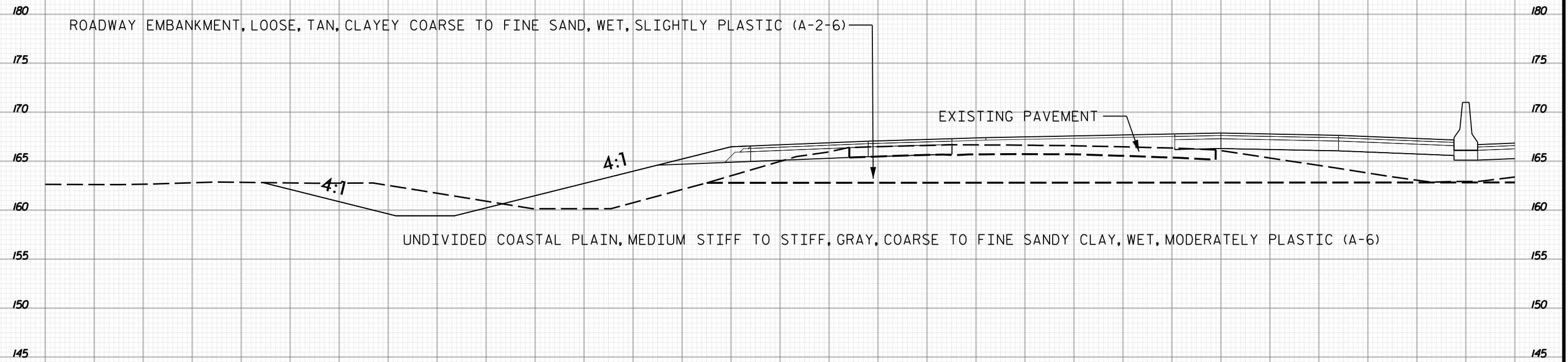

436 + 50
1 OF 2

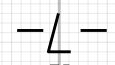

140 135 130 125 120 115 110 105 100 95 90 85 80 75 70 65 60 55 50 45 40 35 30 25 20 15 10 5 0 5



PROJ. REFERENCE NO.	SHEET NO.
I-5987A	791

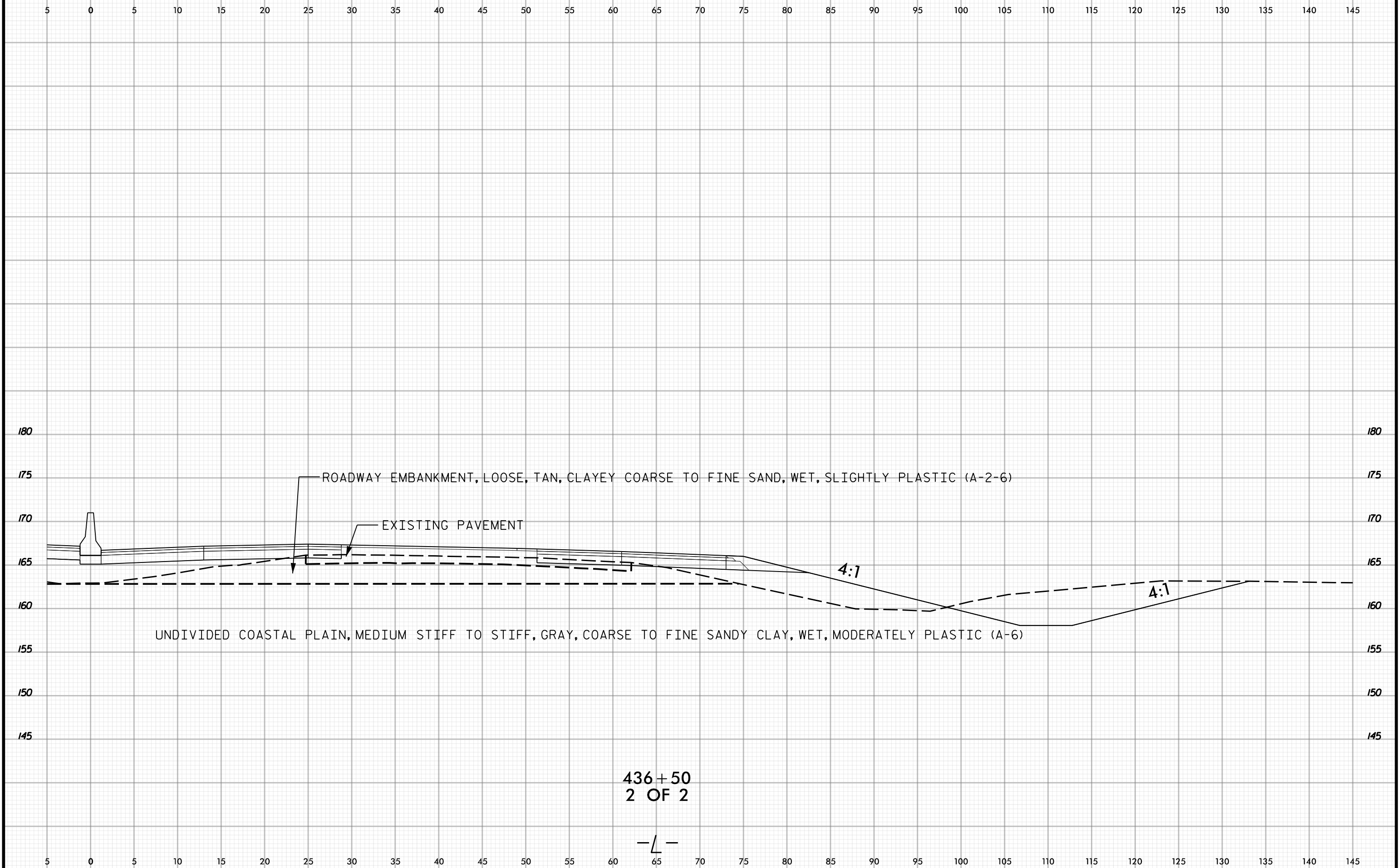

436+50
2 OF 2

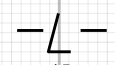



140 135 130 125 120 115 110 105 100 95 90 85 80 75 70 65 60 55 50 45 40 35 30 25 20 15 10 5 0 5

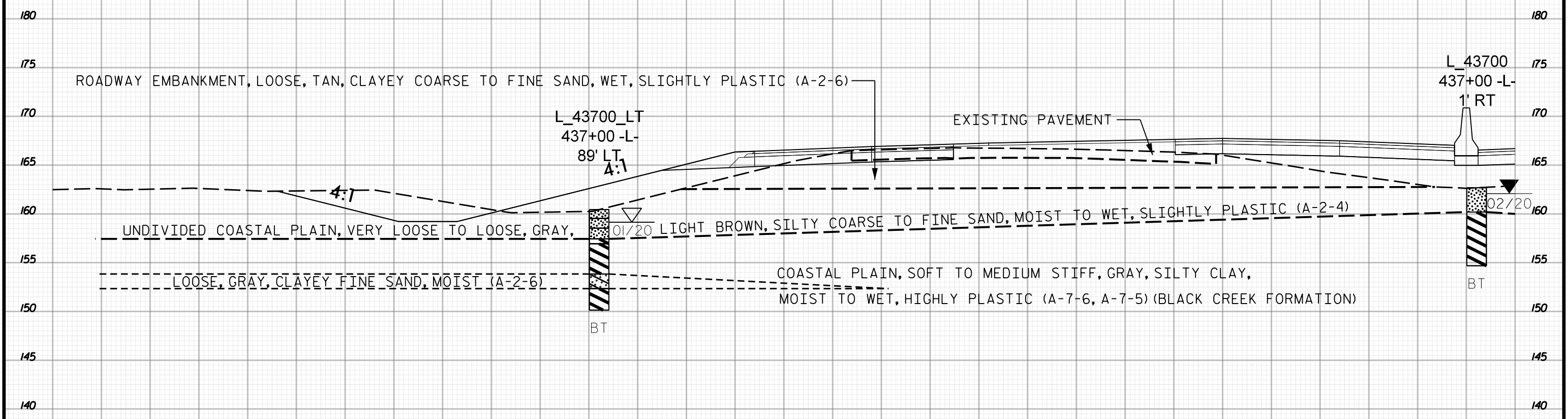

437+00
1 OF 2

140 135 130 125 120 115 110 105 100 95 90 85 80 75 70 65 60 55 50 45 40 35 30 25 20 15 10 5 0 5



5 0 5 10 15 20 25 30 35 40 45 50 55 60 65 70 75 80 85 90 95 100 105 110 115 120 125 130 135 140 145

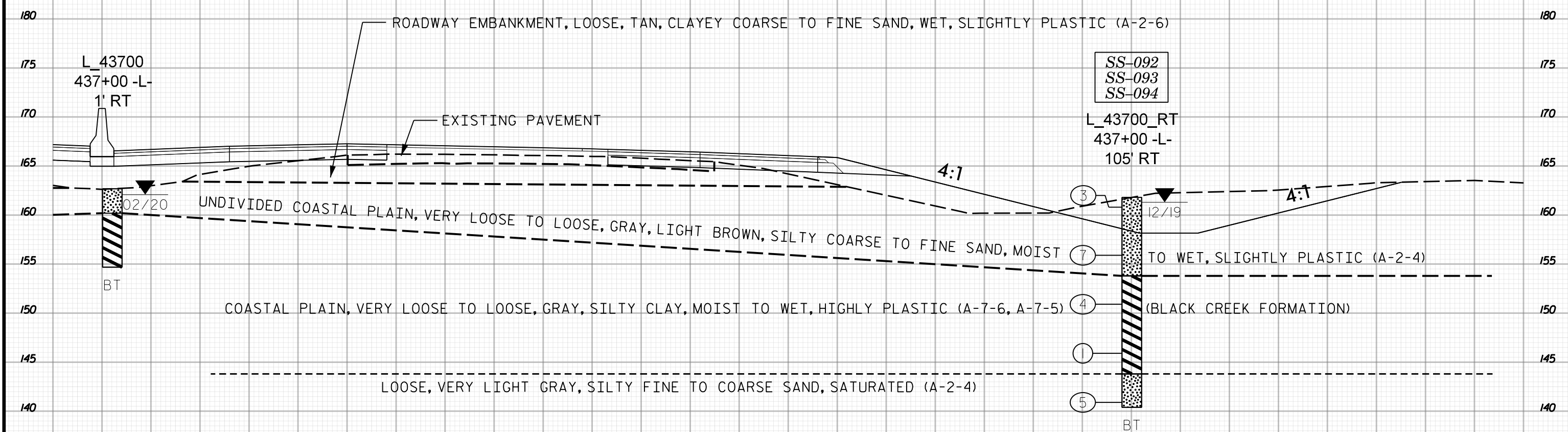

437+00
2 OF 2

-L-

5 0 5 10 15 20 25 30 35 40 45 50 55 60 65 70 75 80 85 90 95 100 105 110 115 120 125 130 135 140 145



140 135 130 125 120 115 110 105 100 95 90 85 80 75 70 65 60 55 50 45 40 35 30 25 20 15 10 5 0 5

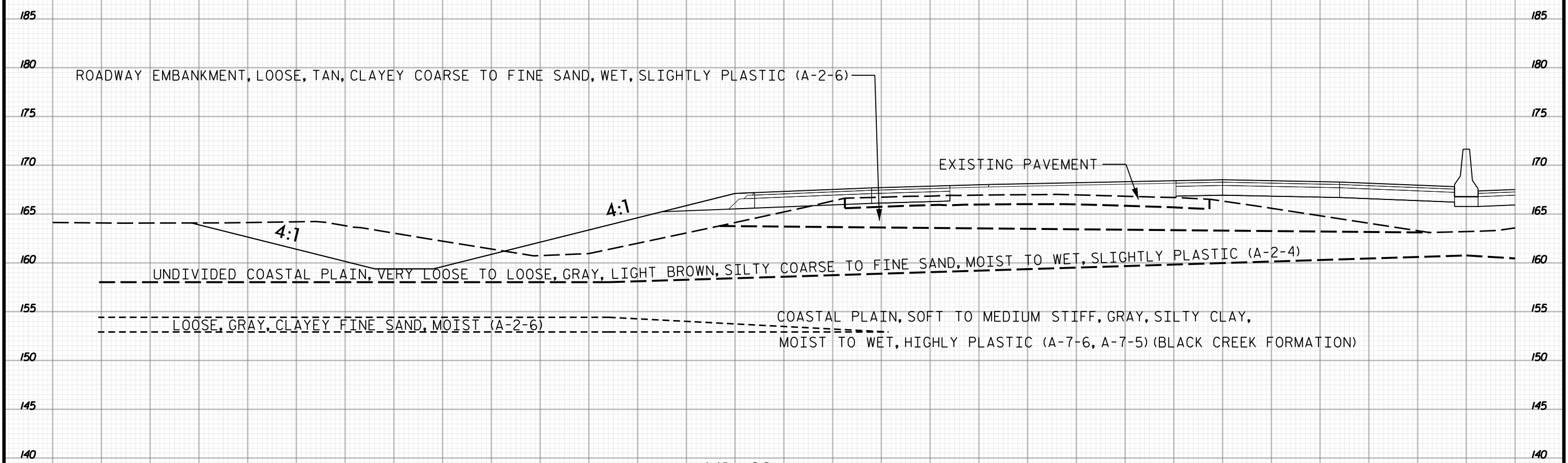

441+00
1 OF 2

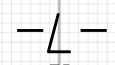

140 135 130 125 120 115 110 105 100 95 90 85 80 75 70 65 60 55 50 45 40 35 30 25 20 15 10 5 0 5



PROJ. REFERENCE NO.	SHEET NO.
I-5987A	795

5 0 5 10 15 20 25 30 35 40 45 50 55 60 65 70 75 80 85 90 95 100 105 110 115 120 125 130 135 140 145

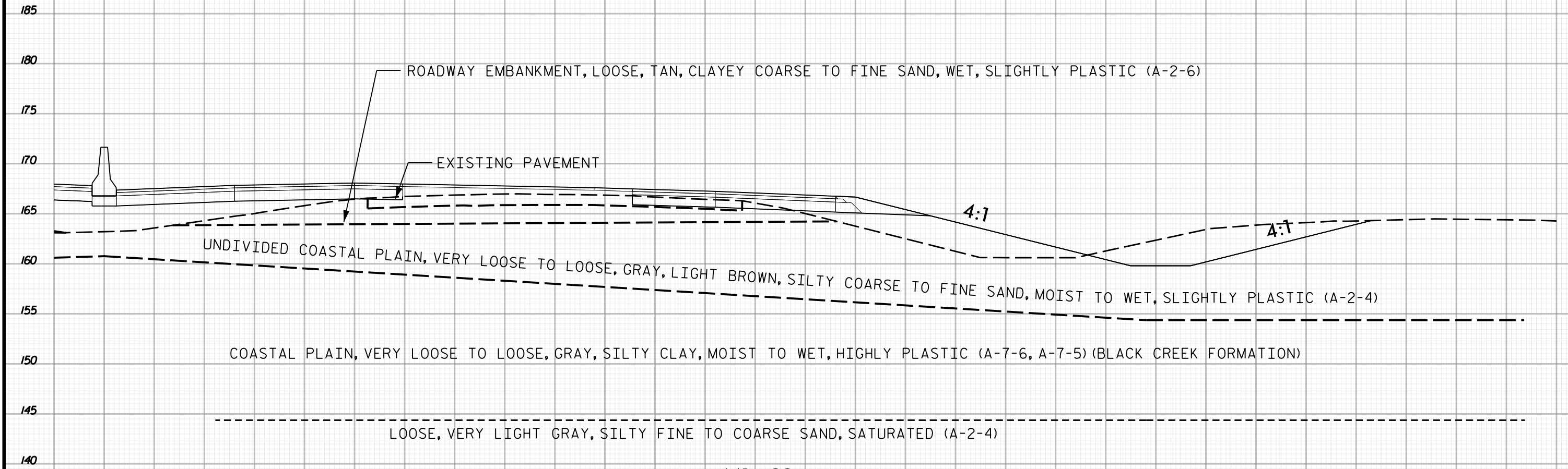

441+00
2 OF 2

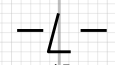

5 0 5 10 15 20 25 30 35 40 45 50 55 60 65 70 75 80 85 90 95 100 105 110 115 120 125 130 135 140 145

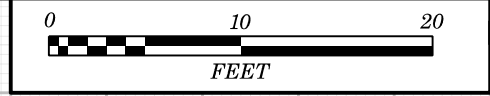

140 135 130 125 120 115 110 105 100 95 90 85 80 75 70 65 60 55 50 45 40 35 30 25 20 15 10 5 0 5

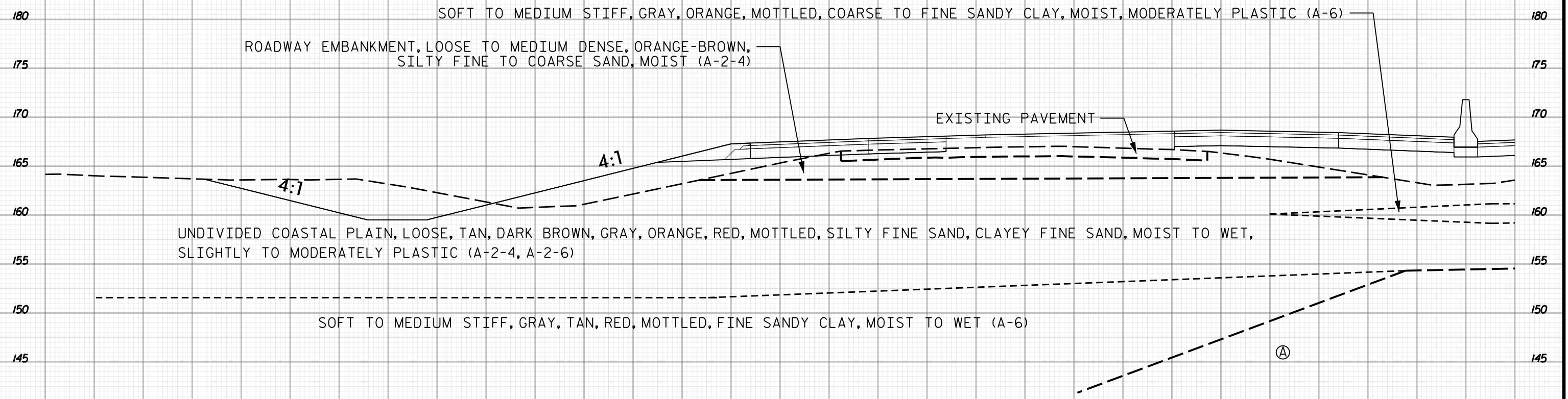

Ⓐ COASTAL PLAIN, LOOSE TO MEDIUM DENSE, LIGHT GRAY, RED, SILTY COARSE TO FINE SAND, COARSE SAND, SATURATED (A-2-4, A-3) (BLACK CREEK FORMATION)

441 + 50
1 OF 2
-L-

140 135 130 125 120 115 110 105 100 95 90 85 80 75 70 65 60 55 50 45 40 35 30 25 20 15 10 5 0 5



5 0 5 10 15 20 25 30 35 40 45 50 55 60 65 70 75 80 85 90 95 100 105 110 115 120 125 130 135 140 145

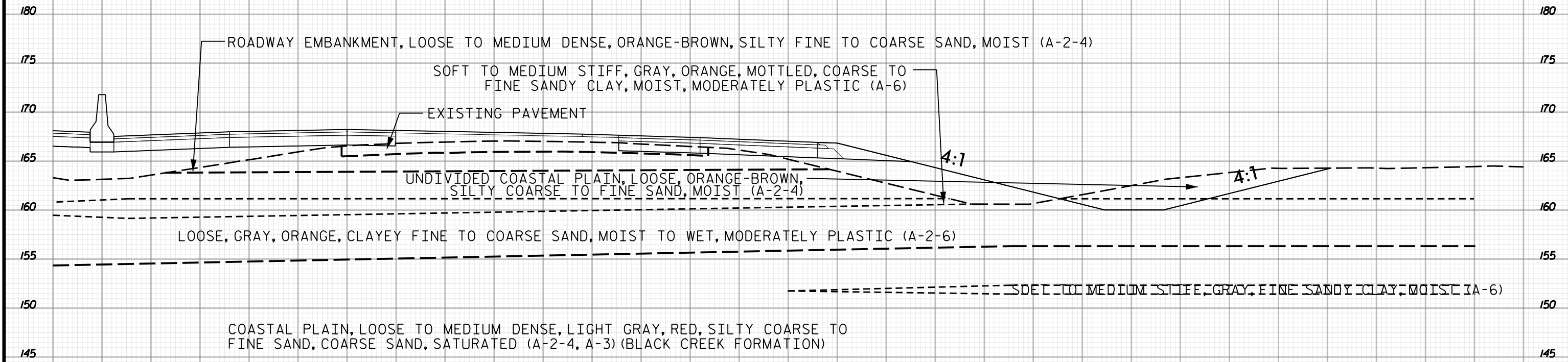

5 0 5 10 15 20 25 30 35 40 45 50 55 60 65 70 75 80 85 90 95 100 105 110 115 120 125 130 135 140 145

441+50
2 OF 2

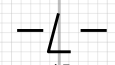



140 135 130 125 120 115 110 105 100 95 90 85 80 75 70 65 60 55 50 45 40 35 30 25 20 15 10 5 0 5

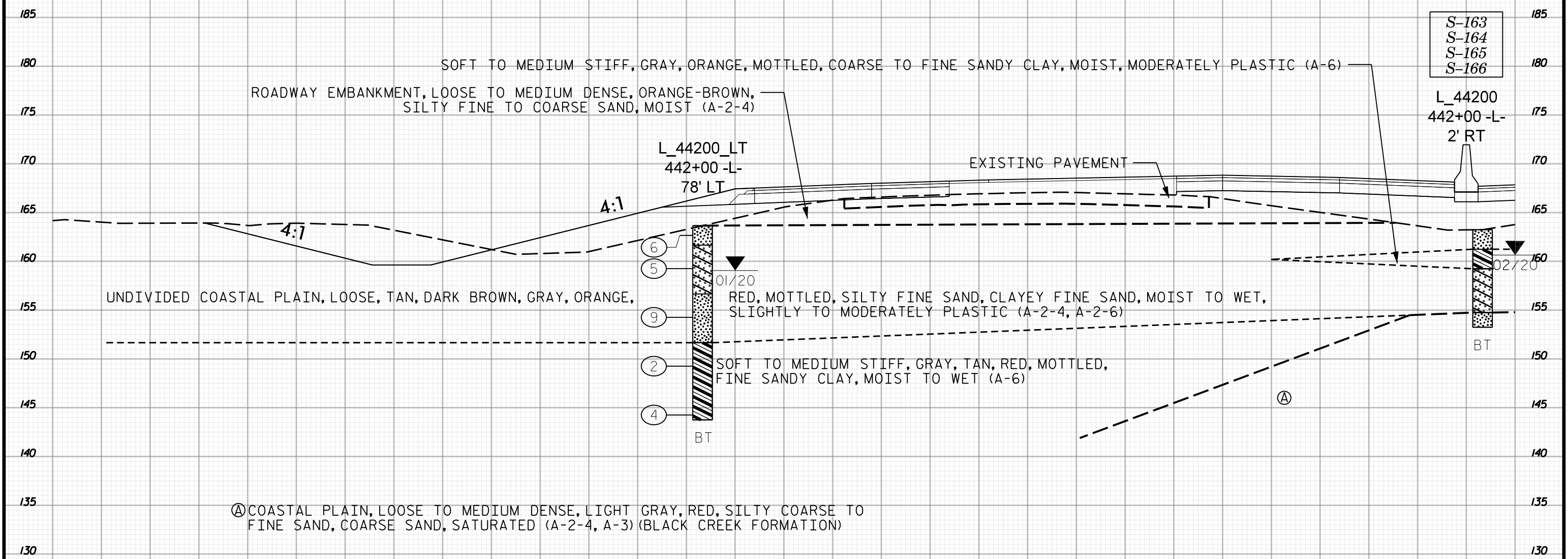

442 + 00
1 OF 2

140 135 130 125 120 115 110 105 100 95 90 85 80 75 70 65 60 55 50 45 40 35 30 25 20 15 10 5 0 5



5 0 5 10 15 20 25 30 35 40 45 50 55 60 65 70 75 80 85 90 95 100 105 110 115 120 125 130 135 140 145

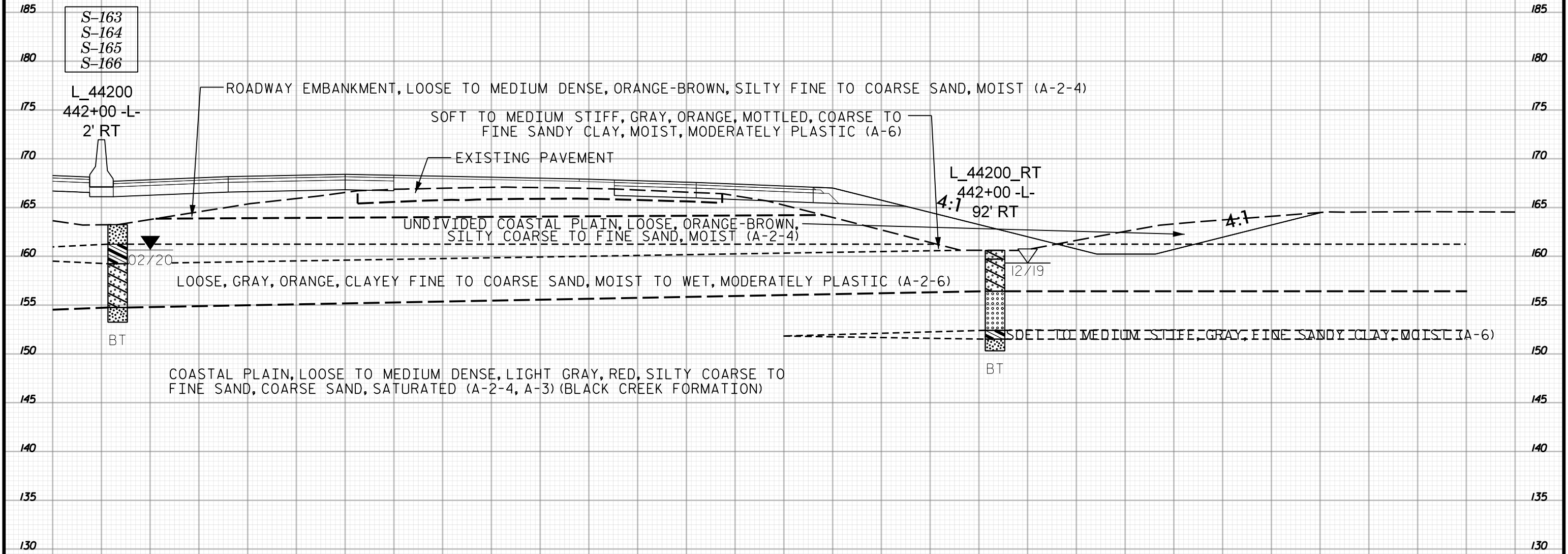

442+00
2 OF 2

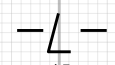

5 0 5 10 15 20 25 30 35 40 45 50 55 60 65 70 75 80 85 90 95 100 105 110 115 120 125 130 135 140 145

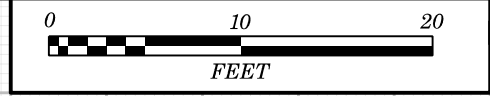

140 135 130 125 120 115 110 105 100 95 90 85 80 75 70 65 60 55 50 45 40 35 30 25 20 15 10 5 0 5

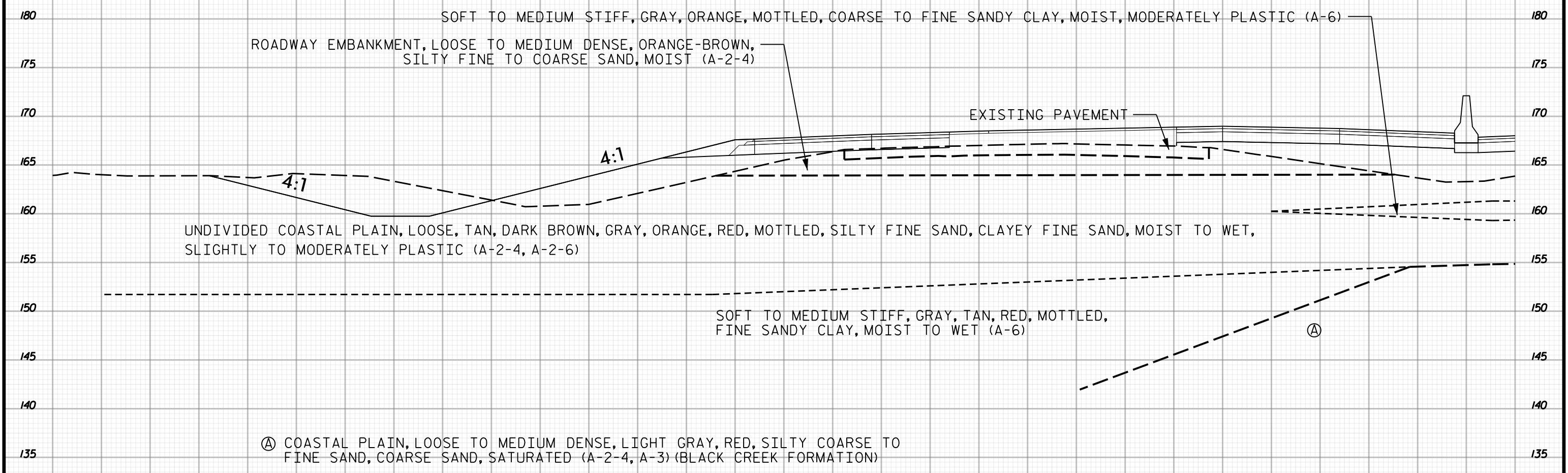

442 + 50
1 OF 2

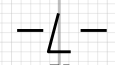

140 135 130 125 120 115 110 105 100 95 90 85 80 75 70 65 60 55 50 45 40 35 30 25 20 15 10 5 0 5

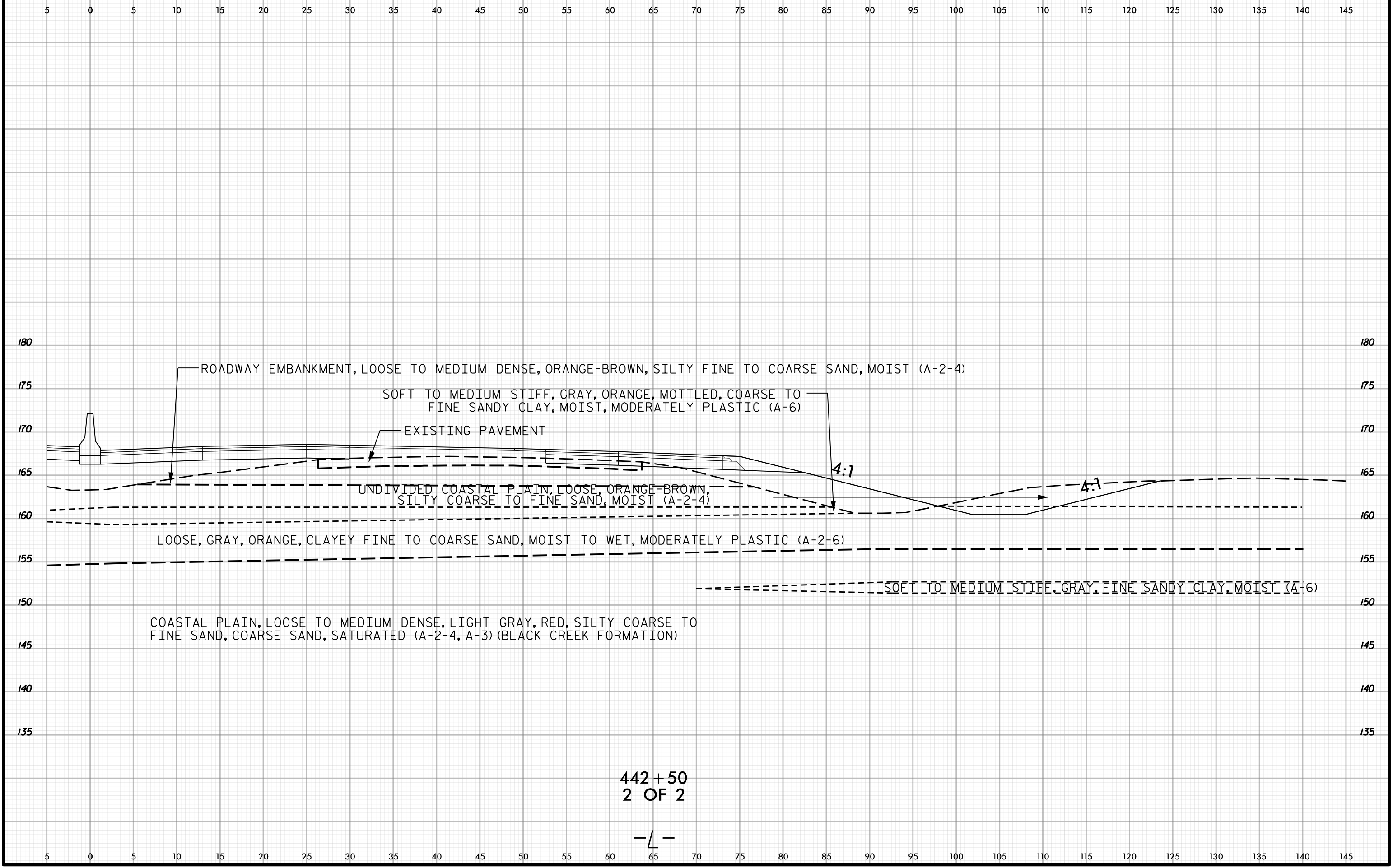
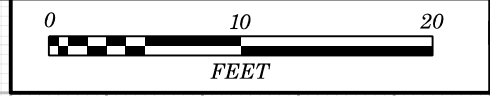

ROADWAY EMBANKMENT, LOOSE TO MEDIUM DENSE, ORANGE-BROWN, SILTY FINE TO COARSE SAND, MOIST (A-2-4)

SOFT TO MEDIUM STIFF, GRAY, ORANGE, MOTTLED, COARSE TO FINE SANDY CLAY, MOIST, MODERATELY PLASTIC (A-6)

EXISTING PAVEMENT

UNDIVIDED COASTAL PLAIN, LOOSE, ORANGE-BROWN, SILTY COARSE TO FINE SAND, MOIST (A-2-4)

LOOSE, GRAY, ORANGE, CLAYEY FINE TO COARSE SAND, MOIST TO WET, MODERATELY PLASTIC (A-2-6)

SOFT TO MEDIUM STIFF, GRAY, FINE SANDY CLAY, MOIST (A-6)

COASTAL PLAIN, LOOSE TO MEDIUM DENSE, LIGHT GRAY, RED, SILTY COARSE TO FINE SAND, COARSE SAND, SATURATED (A-2-4, A-3) (BLACK CREEK FORMATION)

442 + 50
2 OF 2

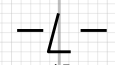



140 135 130 125 120 115 110 105 100 95 90 85 80 75 70 65 60 55 50 45 40 35 30 25 20 15 10 5 0 5

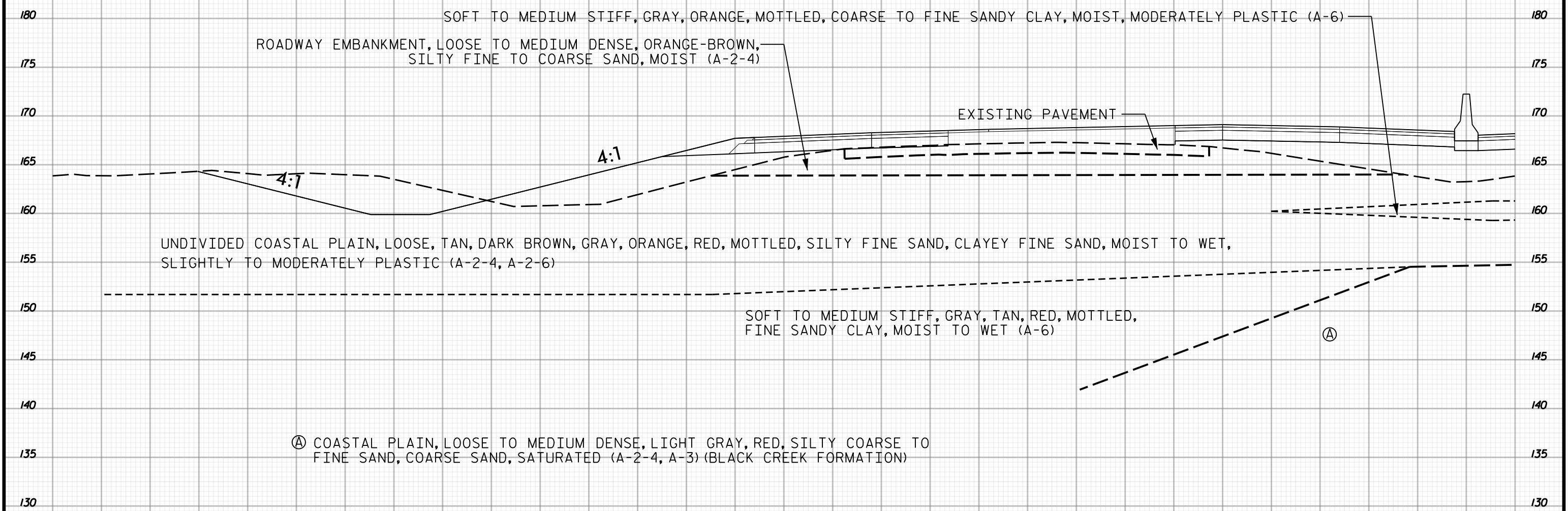

443+00
1 OF 2

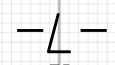

140 135 130 125 120 115 110 105 100 95 90 85 80 75 70 65 60 55 50 45 40 35 30 25 20 15 10 5 0 5

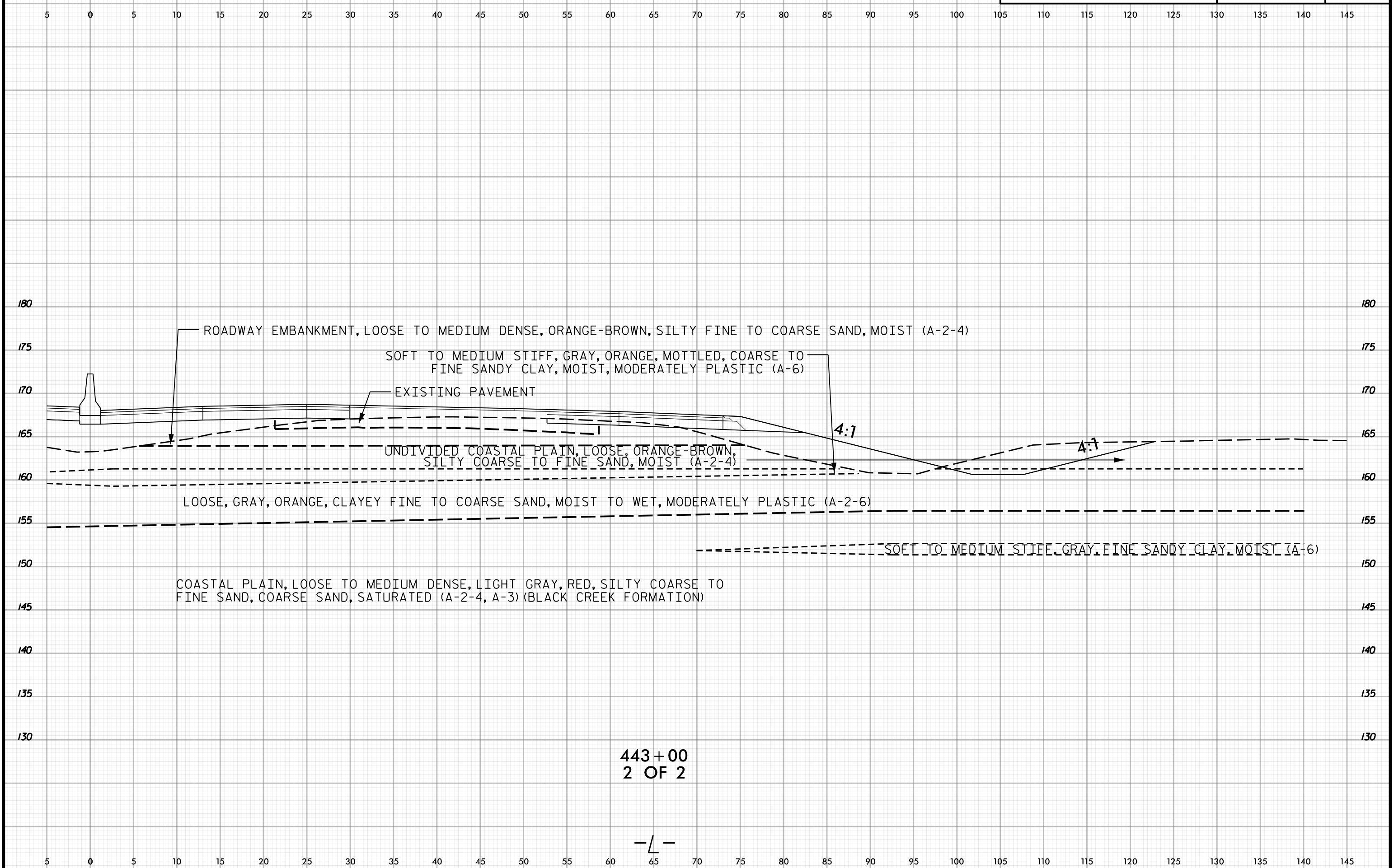

ROADWAY EMBANKMENT, LOOSE TO MEDIUM DENSE, ORANGE-BROWN, SILTY FINE TO COARSE SAND, MOIST (A-2-4)

SOFT TO MEDIUM STIFF, GRAY, ORANGE, MOTTLED, COARSE TO FINE SANDY CLAY, MOIST, MODERATELY PLASTIC (A-6)

EXISTING PAVEMENT

UNDIVIDED COASTAL PLAIN, LOOSE, ORANGE-BROWN, SILTY COARSE TO FINE SAND, MOIST (A-2-4)

LOOSE, GRAY, ORANGE, CLAYEY FINE TO COARSE SAND, MOIST TO WET, MODERATELY PLASTIC (A-2-6)

SOFT TO MEDIUM STIFF, GRAY, FINE SANDY CLAY, MOIST (A-6)

COASTAL PLAIN, LOOSE TO MEDIUM DENSE, LIGHT GRAY, RED, SILTY COARSE TO FINE SAND, COARSE SAND, SATURATED (A-2-4, A-3) (BLACK CREEK FORMATION)

443+00
2 OF 2

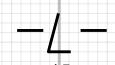

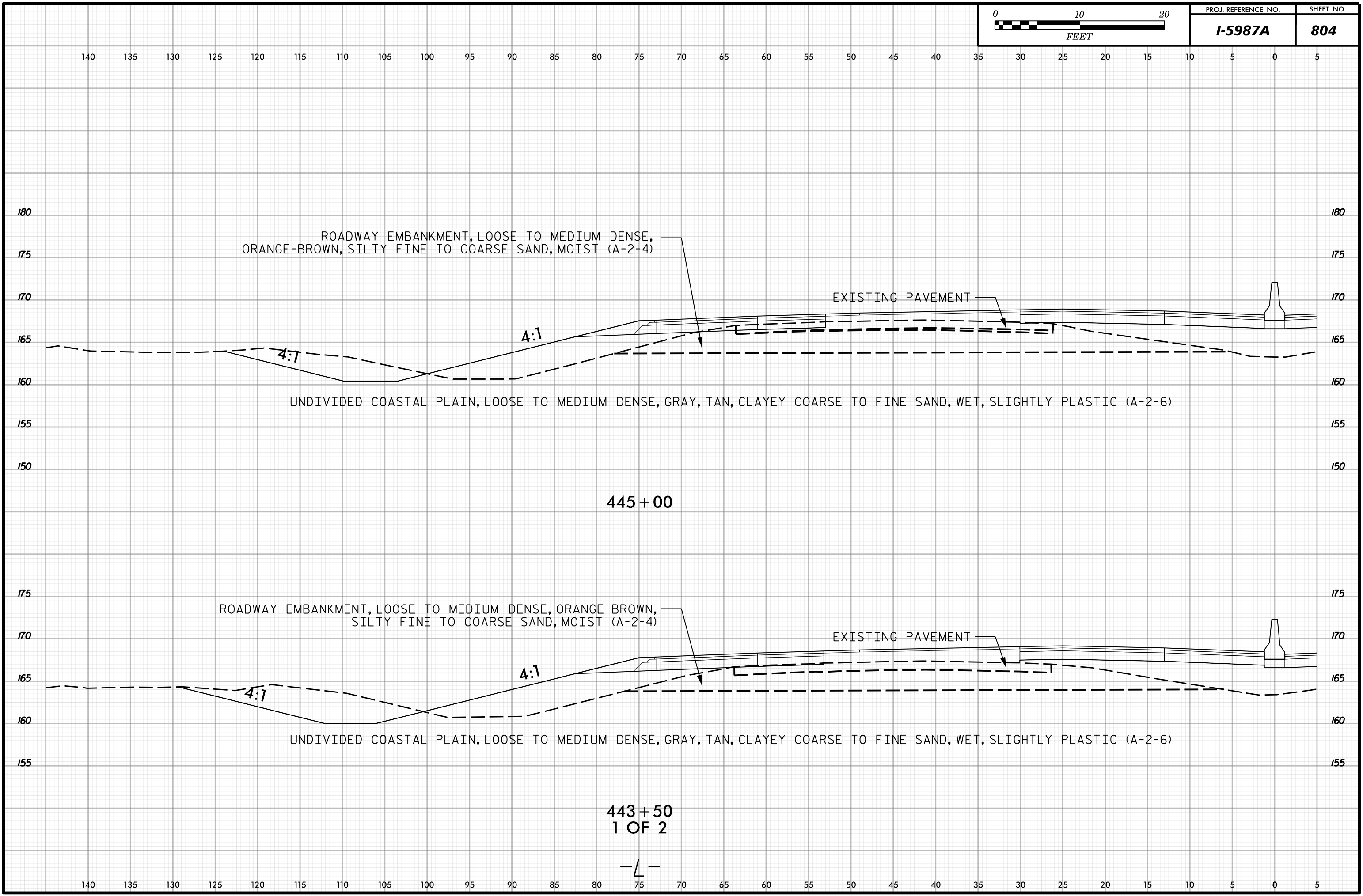

ROADWAY EMBANKMENT, LOOSE TO MEDIUM DENSE,
ORANGE-BROWN, SILTY FINE TO COARSE SAND, MOIST (A-2-4)

EXISTING PAVEMENT

UNDIVIDED COASTAL PLAIN, LOOSE TO MEDIUM DENSE, GRAY, TAN, CLAYEY COARSE TO FINE SAND, WET, SLIGHTLY PLASTIC (A-2-6)

445 + 00

ROADWAY EMBANKMENT, LOOSE TO MEDIUM DENSE, ORANGE-BROWN,
SILTY FINE TO COARSE SAND, MOIST (A-2-4)

EXISTING PAVEMENT

UNDIVIDED COASTAL PLAIN, LOOSE TO MEDIUM DENSE, GRAY, TAN, CLAYEY COARSE TO FINE SAND, WET, SLIGHTLY PLASTIC (A-2-6)

443 + 50
1 OF 2

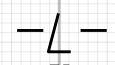

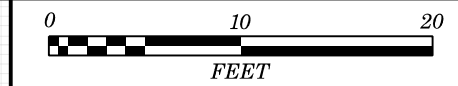

5 0 5 10 15 20 25 30 35 40 45 50 55 60 65 70 75 80 85 90 95 100 105 110 115 120 125 130 135 140 145

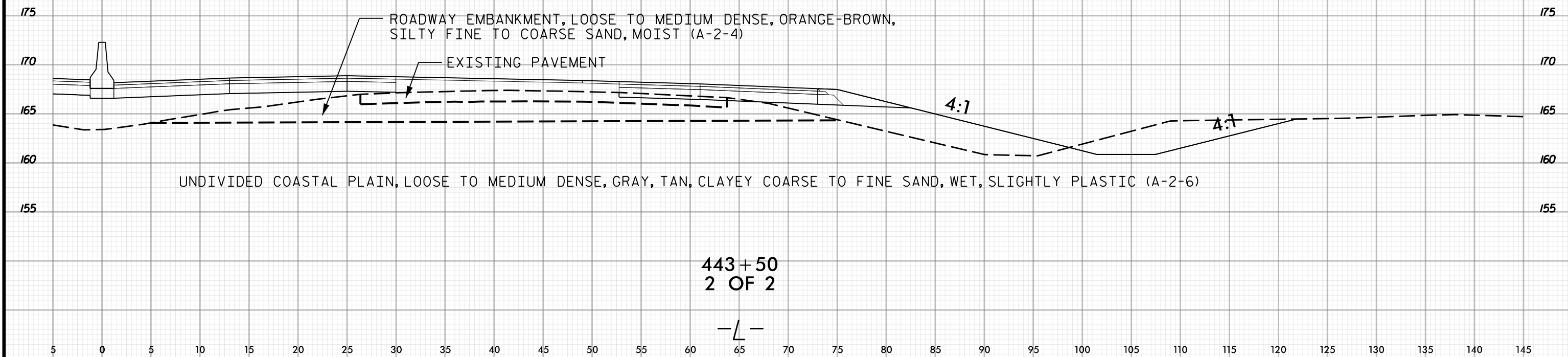
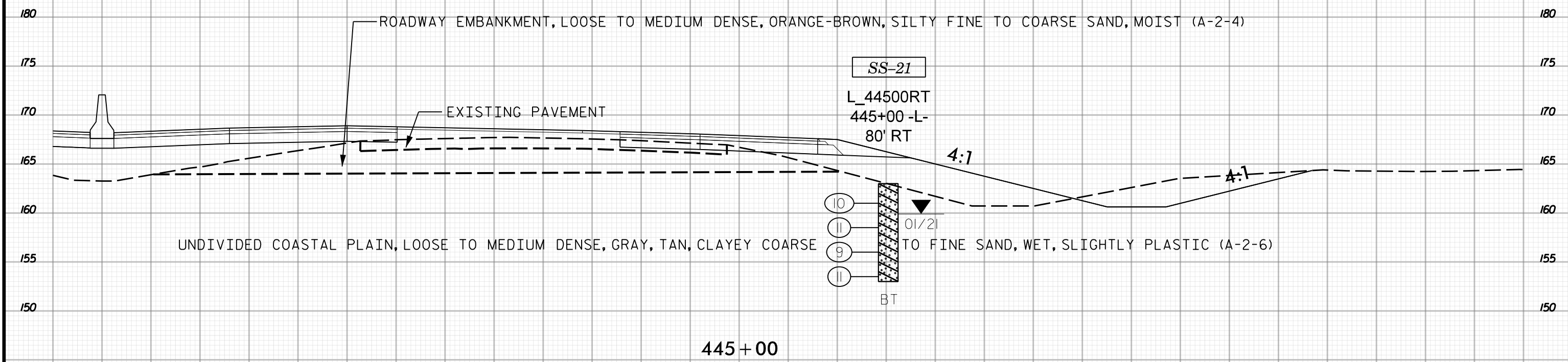



140 135 130 125 120 115 110 105 100 95 90 85 80 75 70 65 60 55 50 45 40 35 30 25 20 15 10 5 0 5

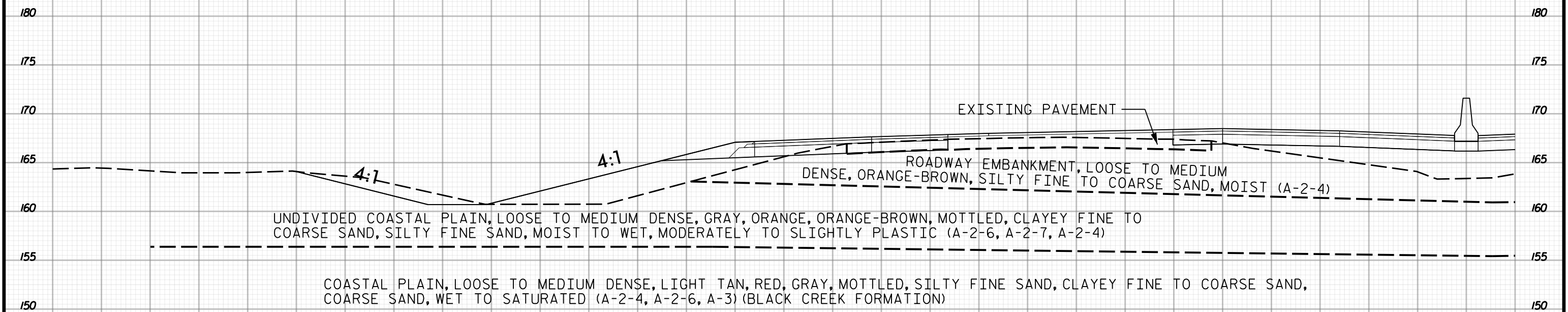

446 + 50

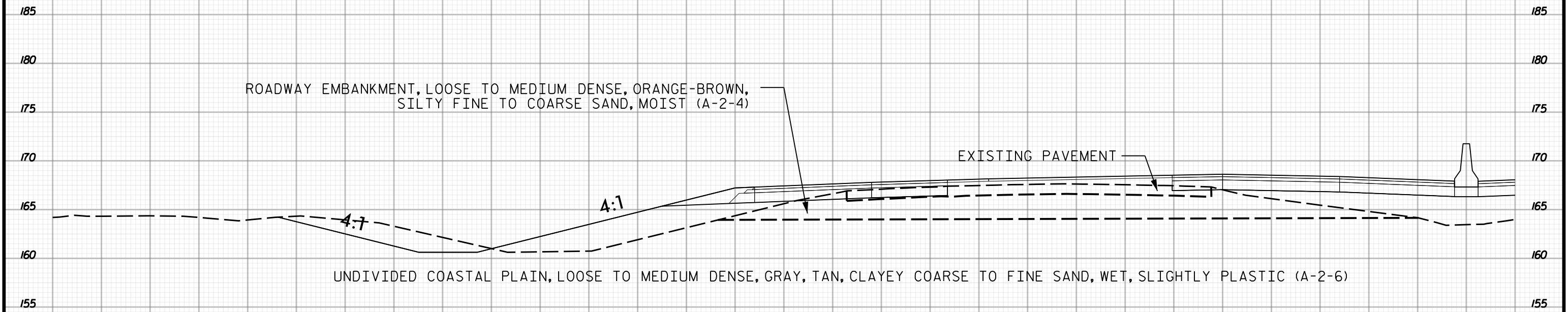

446 + 00
1 OF 2

140 135 130 125 120 115 110 105 100 95 90 85 80 75 70 65 60 55 50 45 40 35 30 25 20 15 10 5 0 5



5 0 5 10 15 20 25 30 35 40 45 50 55 60 65 70 75 80 85 90 95 100 105 110 115 120 125 130 135 140 145

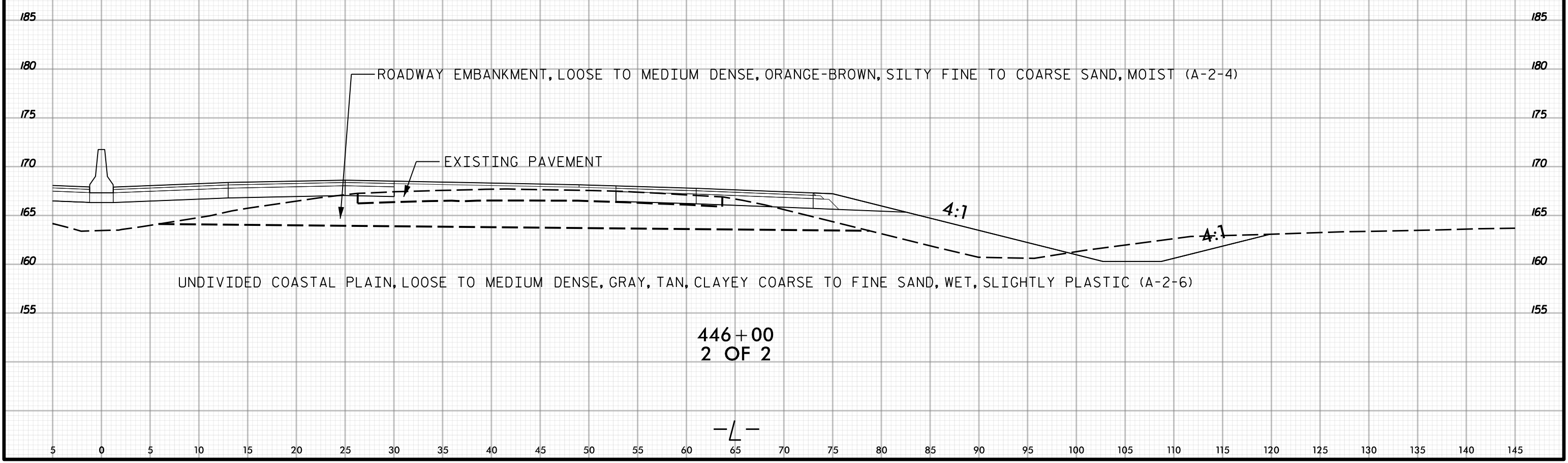
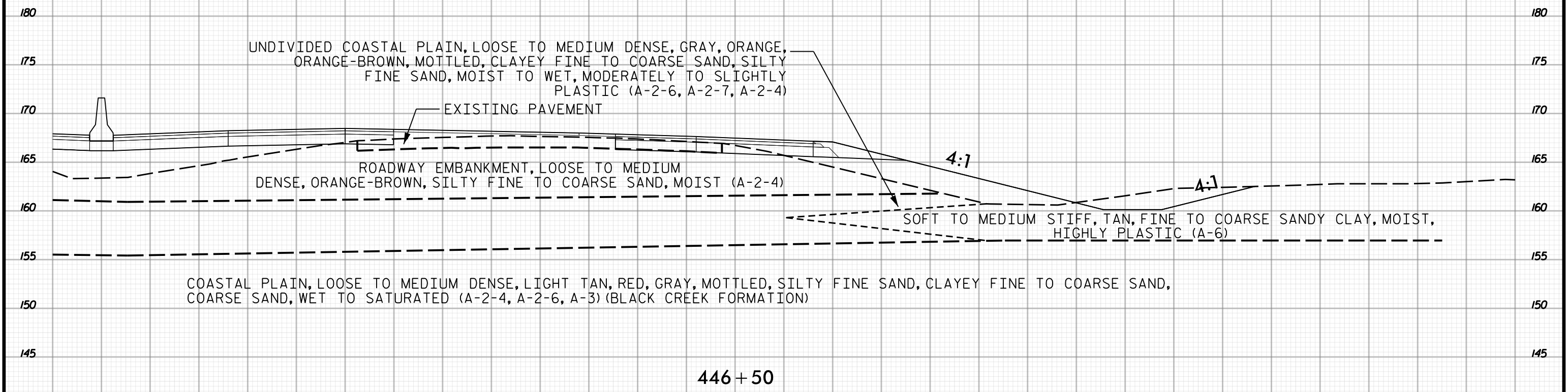

5 0 5 10 15 20 25 30 35 40 45 50 55 60 65 70 75 80 85 90 95 100 105 110 115 120 125 130 135 140 145

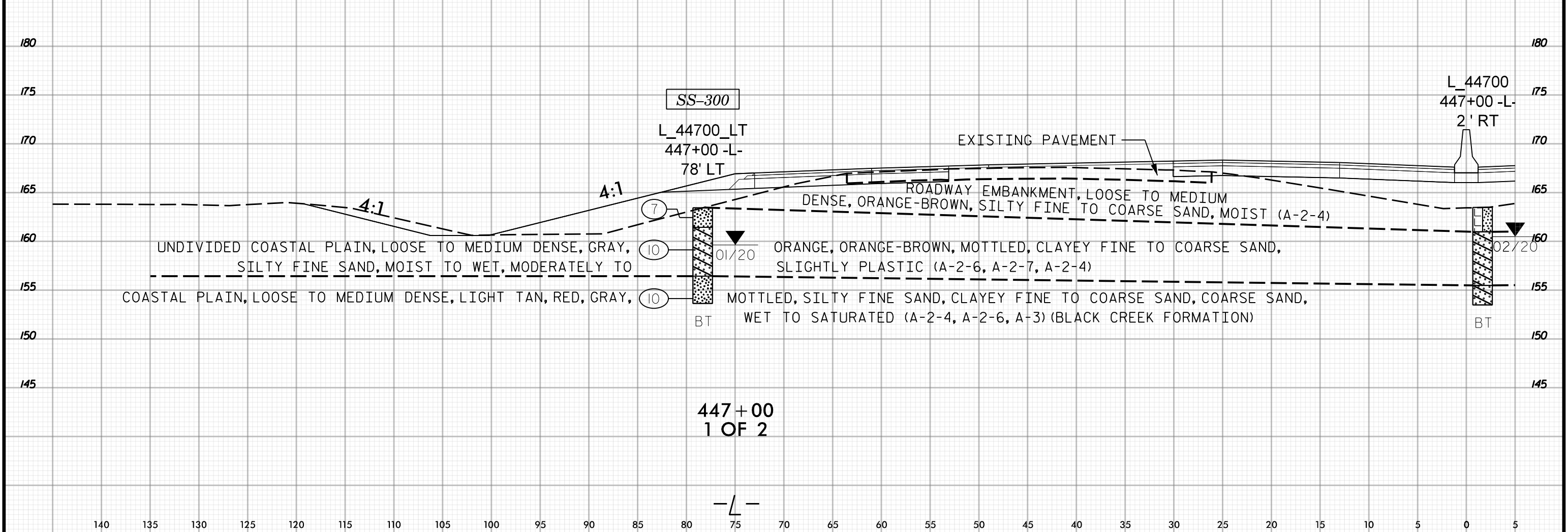
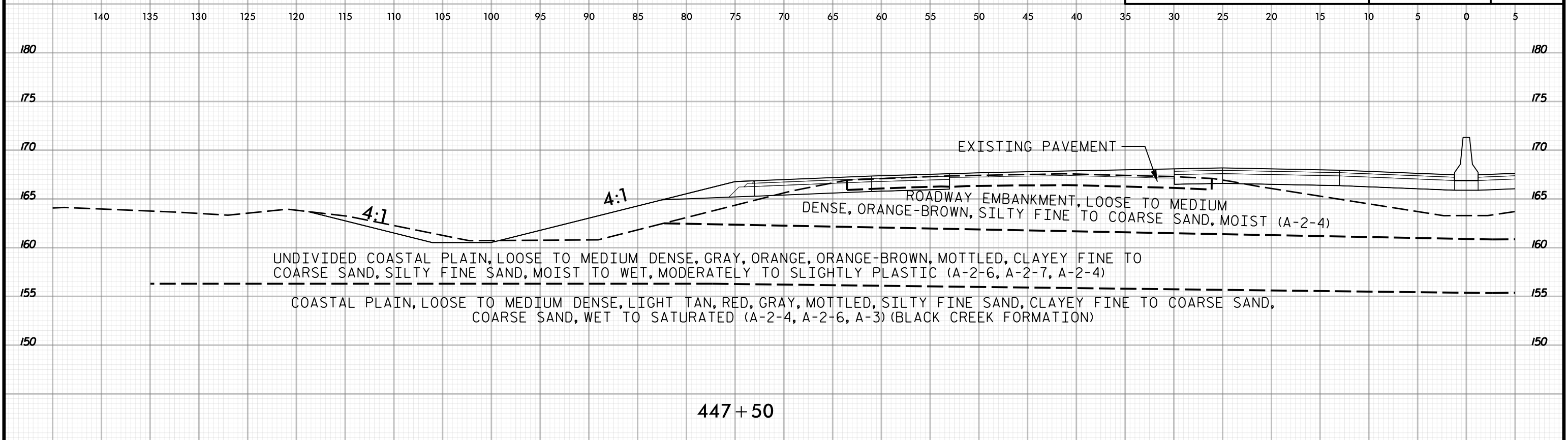

447+00
1 OF 2

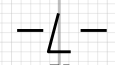

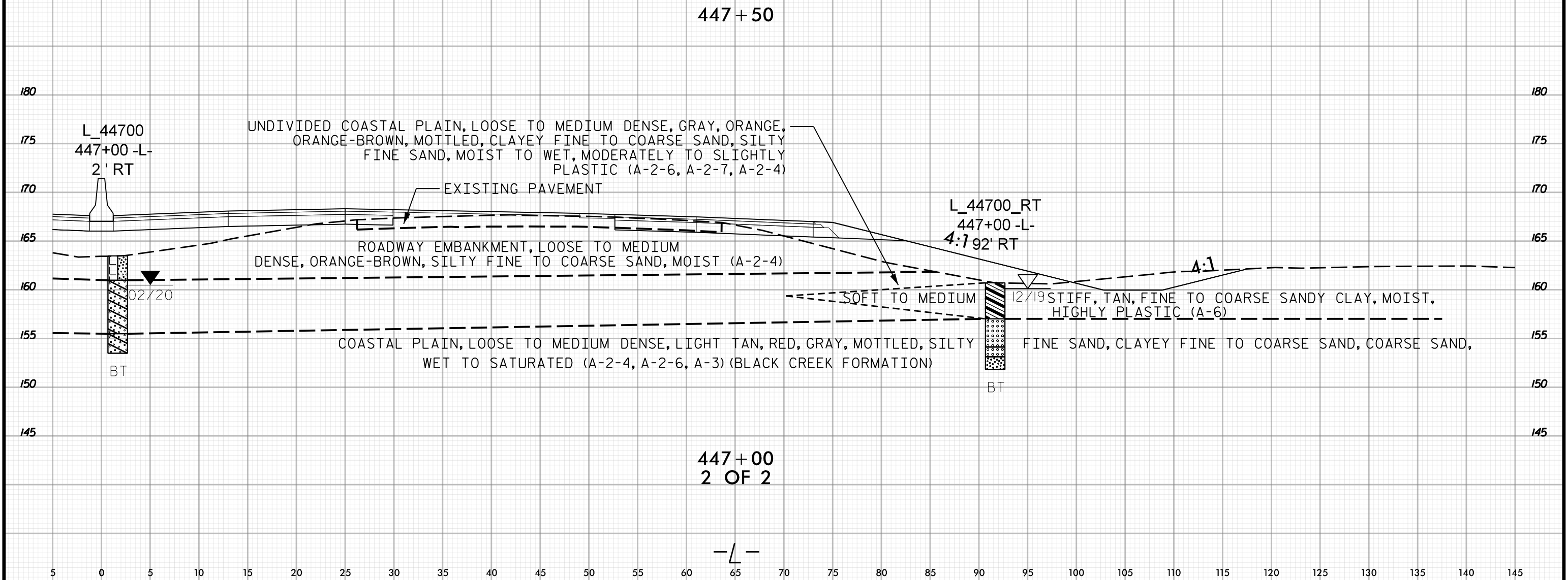
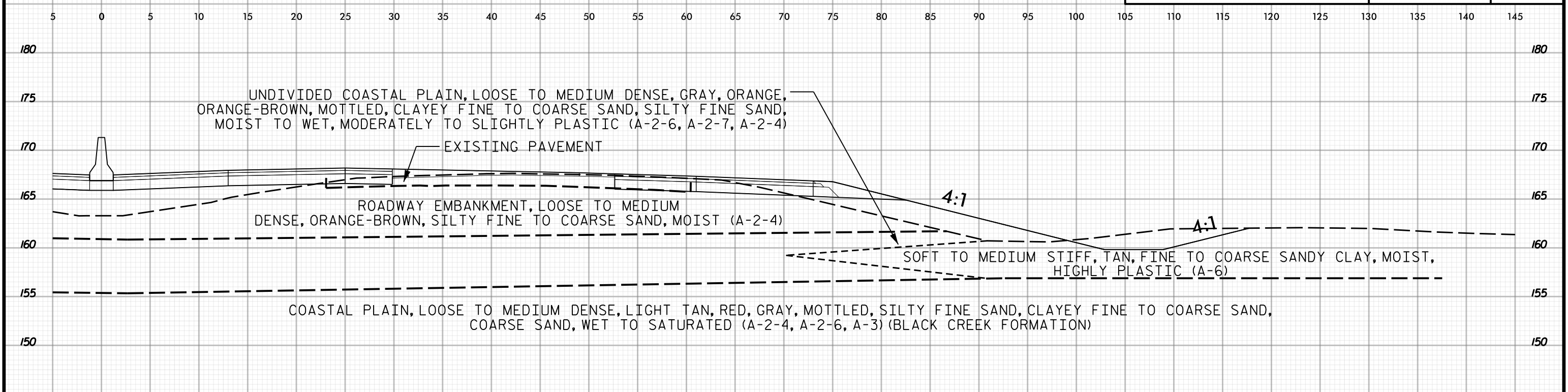
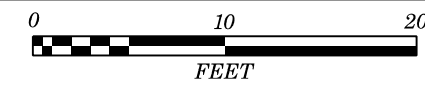

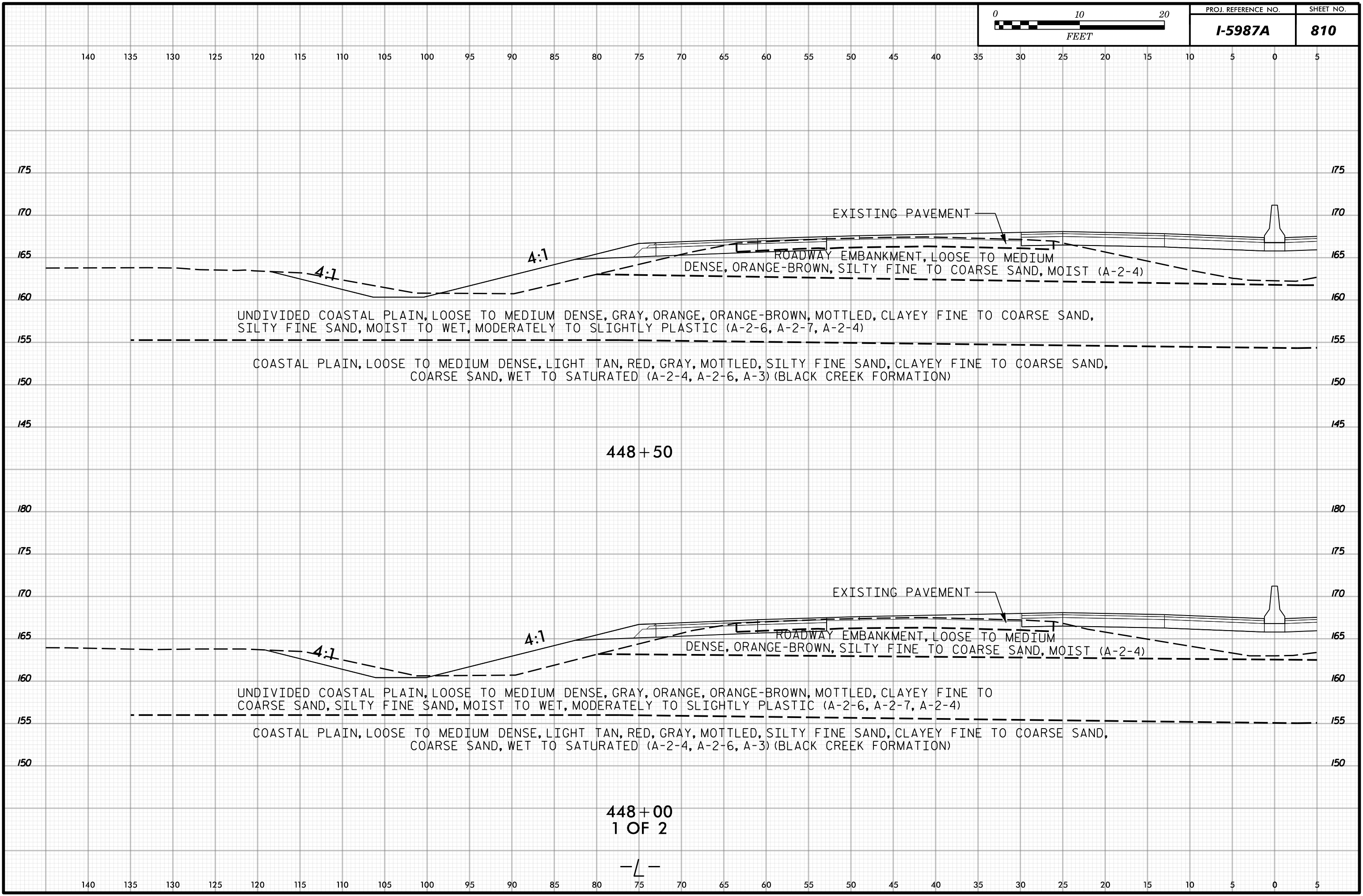

448 + 50

448 + 00
1 OF 2

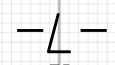



5 0 5 10 15 20 25 30 35 40 45 50 55 60 65 70 75 80 85 90 95 100 105 110 115 120 125 130 135 140 145

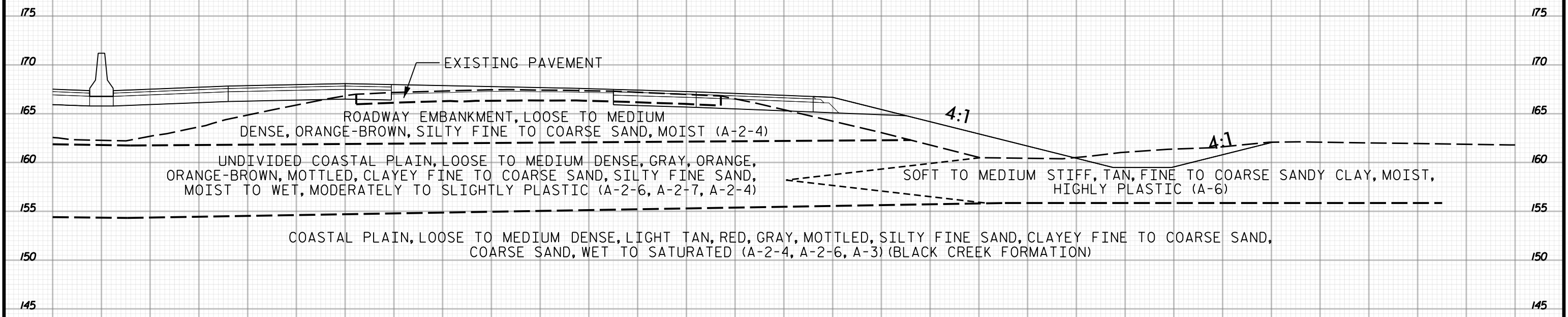

448 + 50

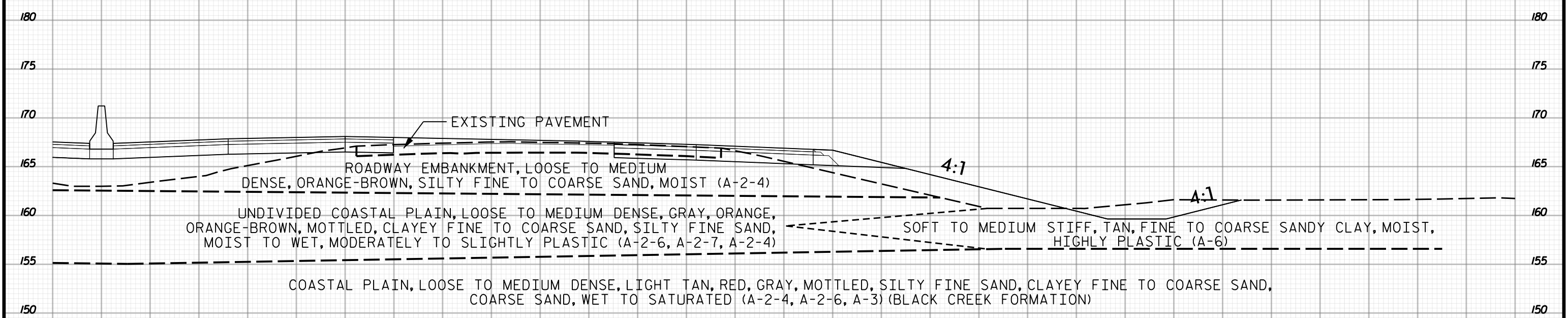

448 + 00
2 OF 2

5 0 5 10 15 20 25 30 35 40 45 50 55 60 65 70 75 80 85 90 95 100 105 110 115 120 125 130 135 140 145



140 135 130 125 120 115 110 105 100 95 90 85 80 75 70 65 60 55 50 45 40 35 30 25 20 15 10 5 0 5

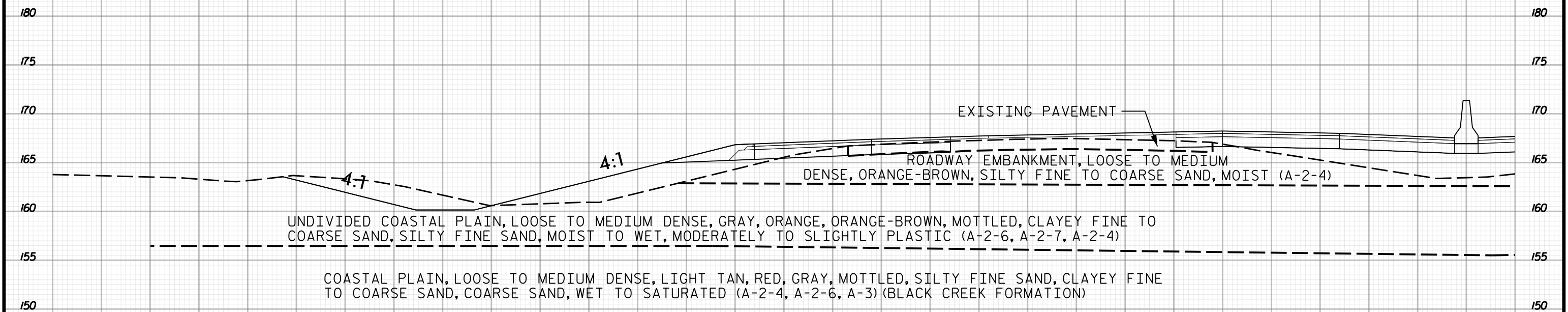

449 + 50

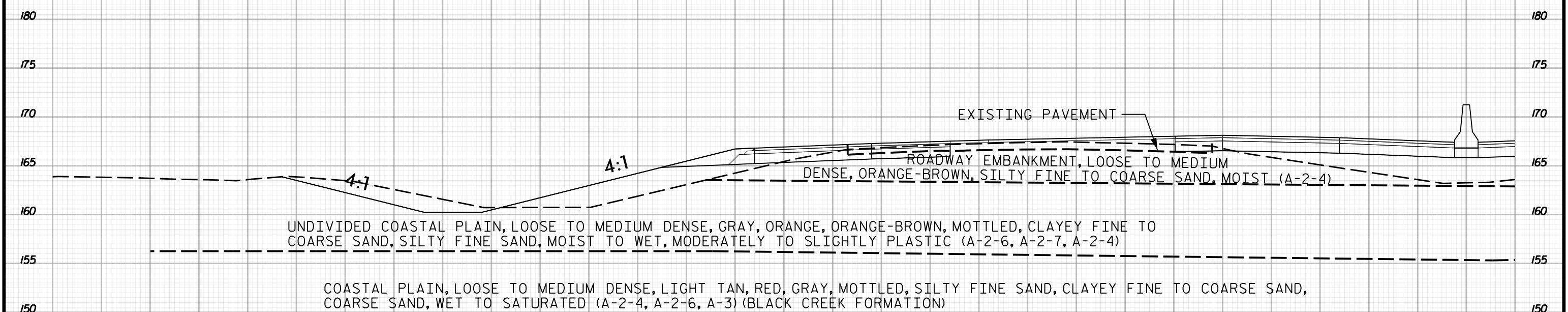

449 + 00
1 OF 2

140 135 130 125 120 115 110 105 100 95 90 85 80 75 70 65 60 55 50 45 40 35 30 25 20 15 10 5 0 5

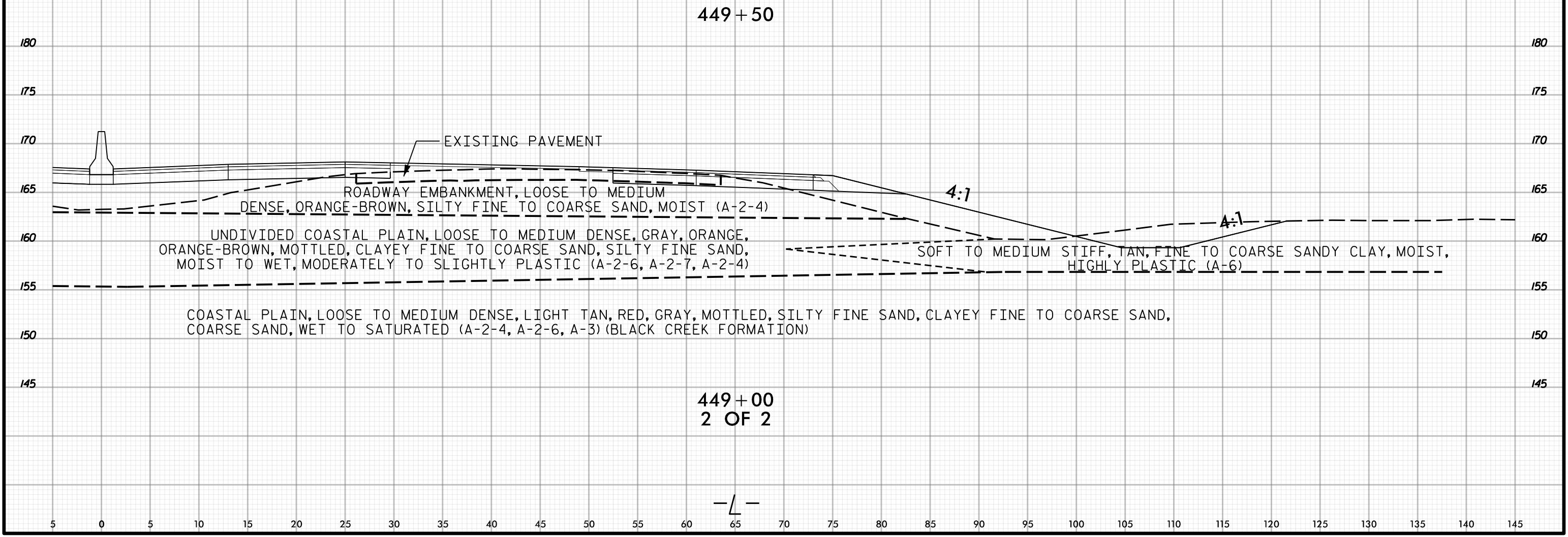
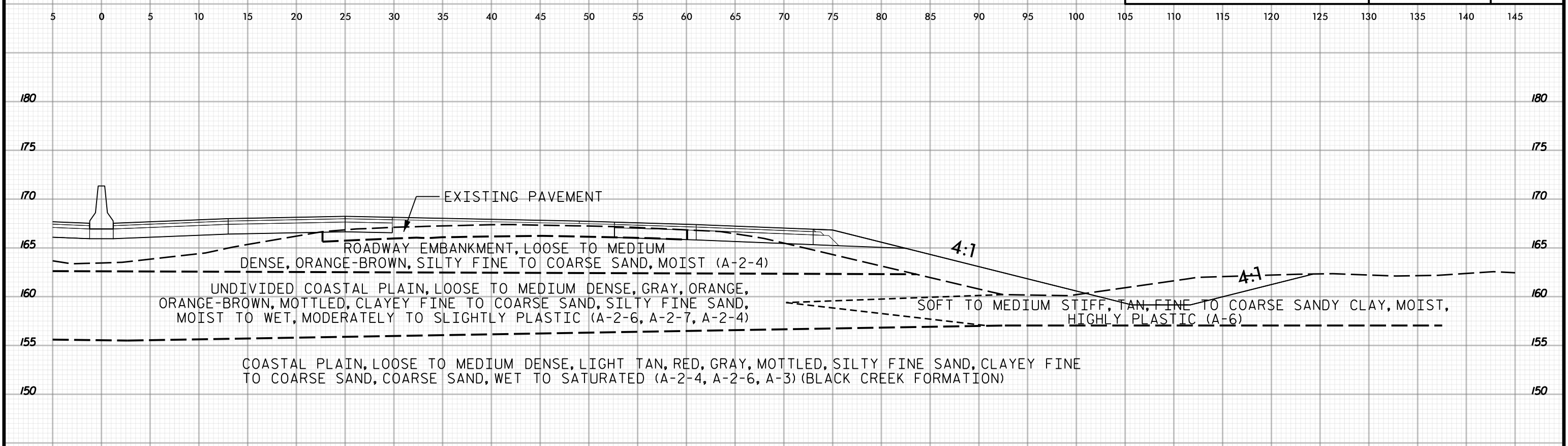



140 135 130 125 120 115 110 105 100 95 90 85 80 75 70 65 60 55 50 45 40 35 30 25 20 15 10 5 0 5

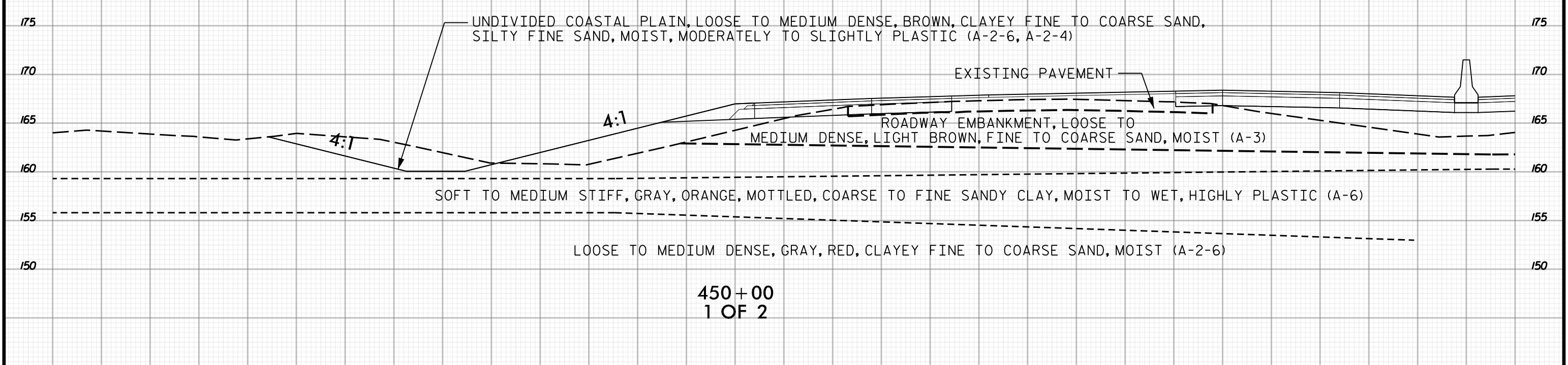
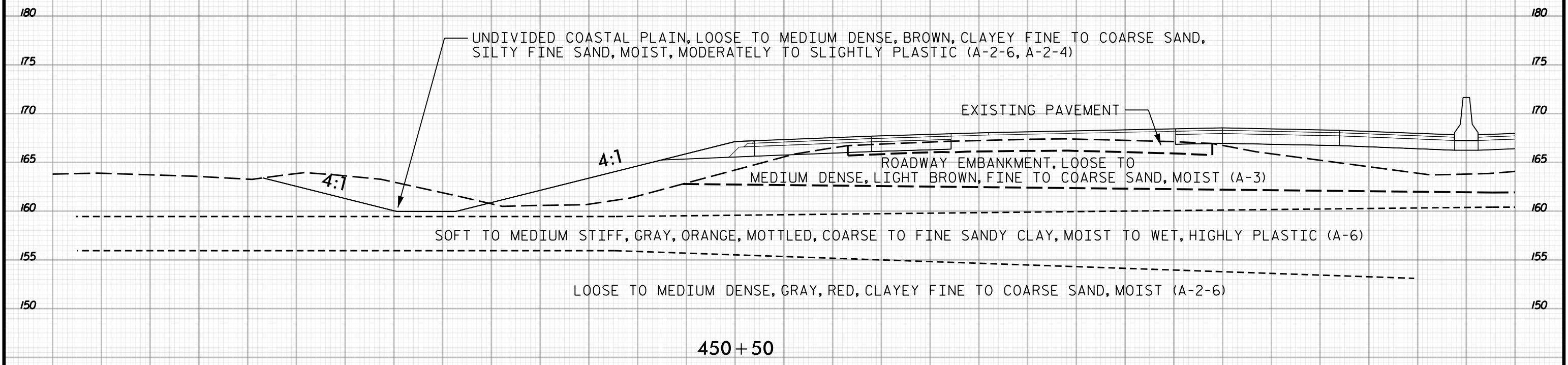

140 135 130 125 120 115 110 105 100 95 90 85 80 75 70 65 60 55 50 45 40 35 30 25 20 15 10 5 0 5

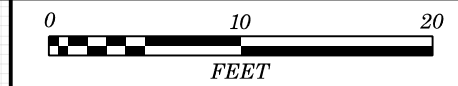

5 0 5 10 15 20 25 30 35 40 45 50 55 60 65 70 75 80 85 90 95 100 105 110 115 120 125 130 135 140 145

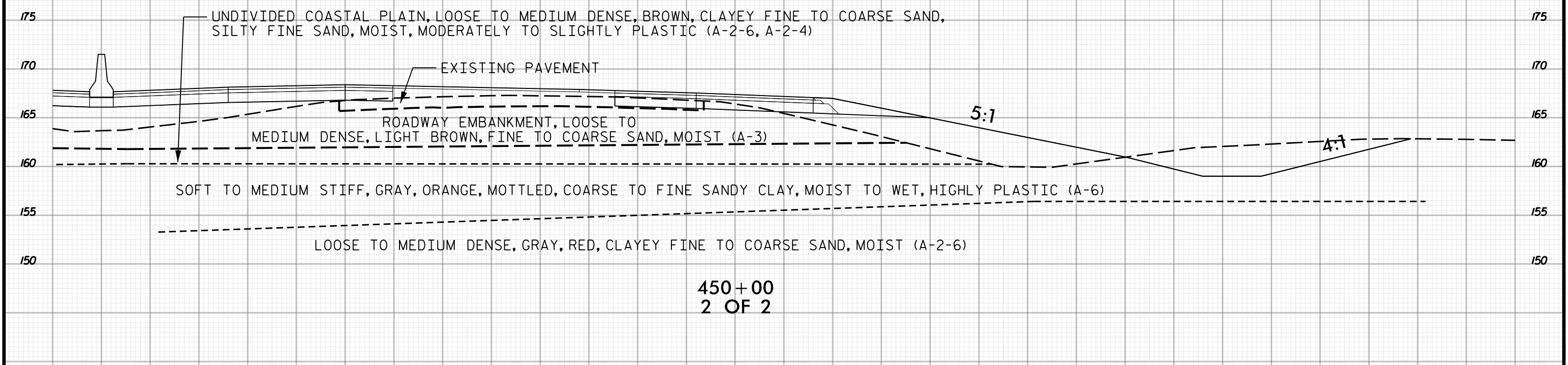
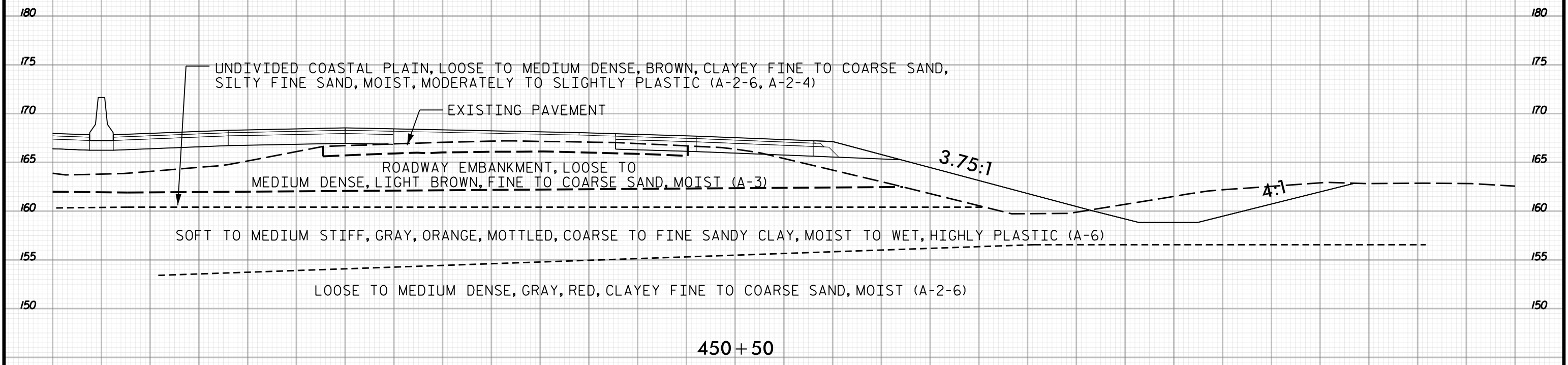

5 0 5 10 15 20 25 30 35 40 45 50 55 60 65 70 75 80 85 90 95 100 105 110 115 120 125 130 135 140 145

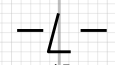



140 135 130 125 120 115 110 105 100 95 90 85 80 75 70 65 60 55 50 45 40 35 30 25 20 15 10 5 0 5

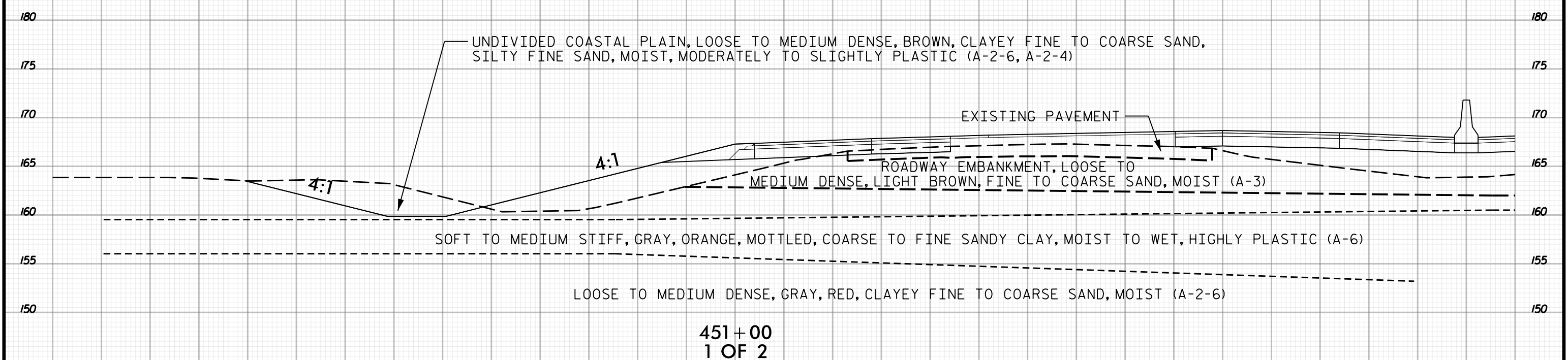
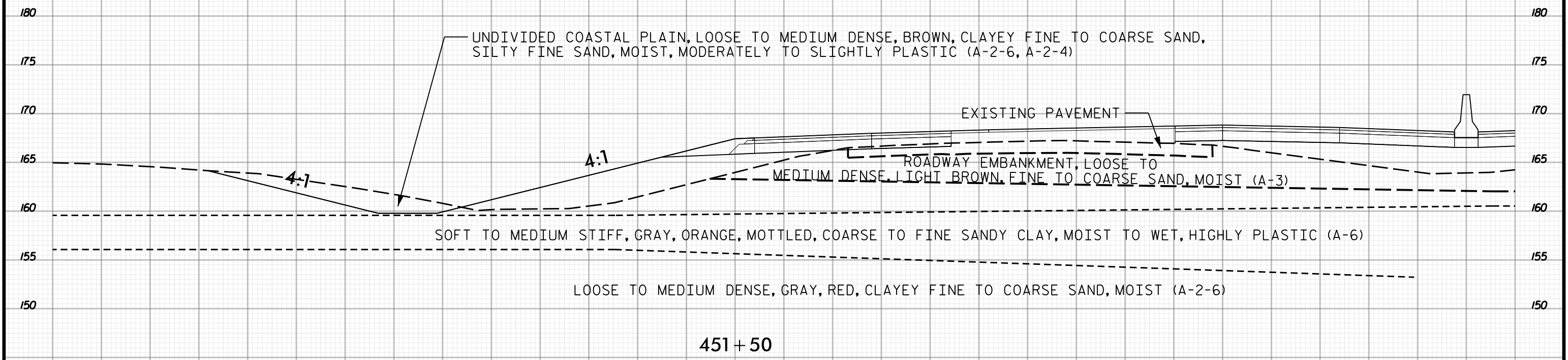

140 135 130 125 120 115 110 105 100 95 90 85 80 75 70 65 60 55 50 45 40 35 30 25 20 15 10 5 0 5

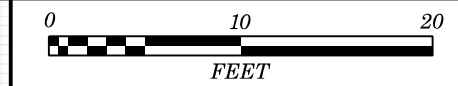

5 0 5 10 15 20 25 30 35 40 45 50 55 60 65 70 75 80 85 90 95 100 105 110 115 120 125 130 135 140 145

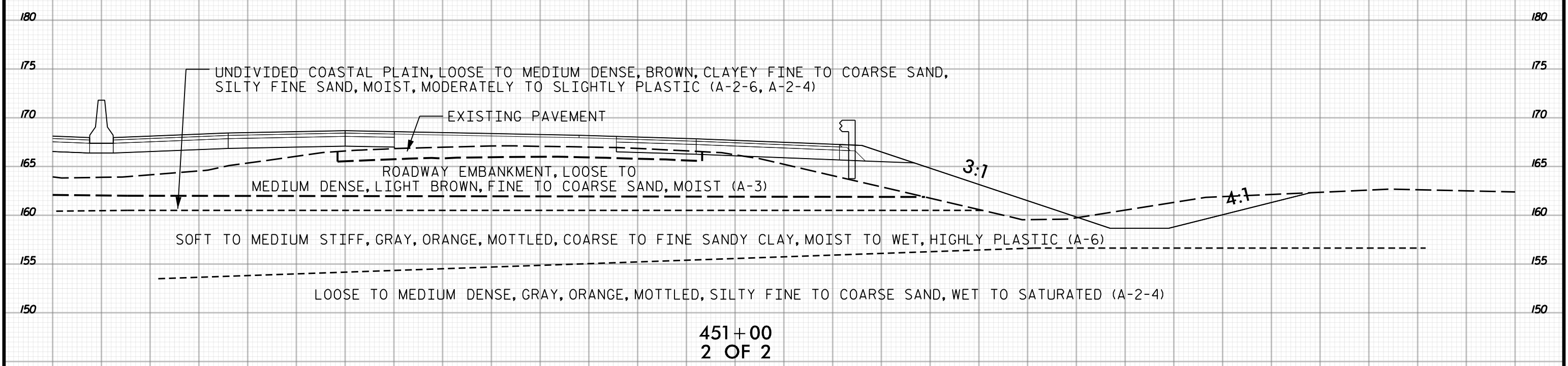
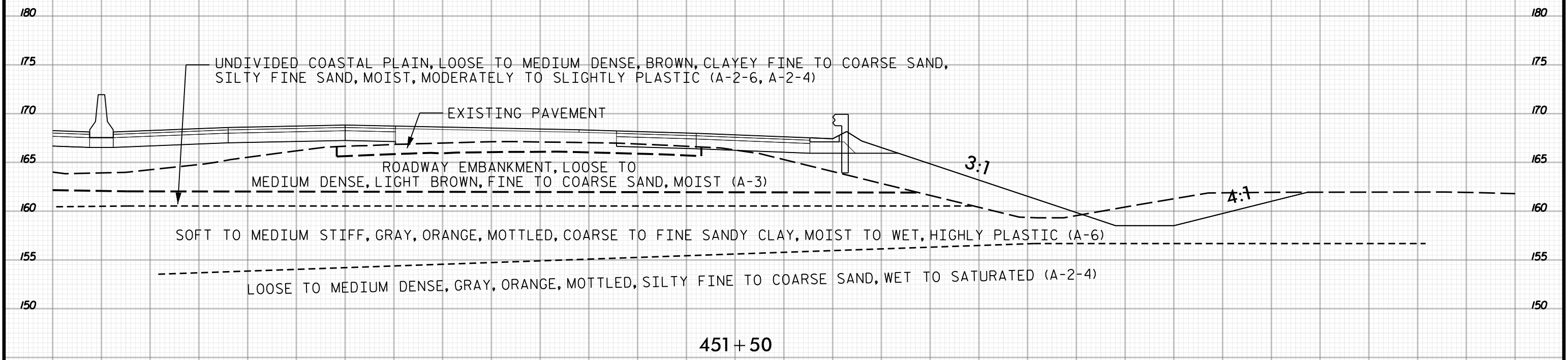

5 0 5 10 15 20 25 30 35 40 45 50 55 60 65 70 75 80 85 90 95 100 105 110 115 120 125 130 135 140 145



140 135 130 125 120 115 110 105 100 95 90 85 80 75 70 65 60 55 50 45 40 35 30 25 20 15 10 5 0 5

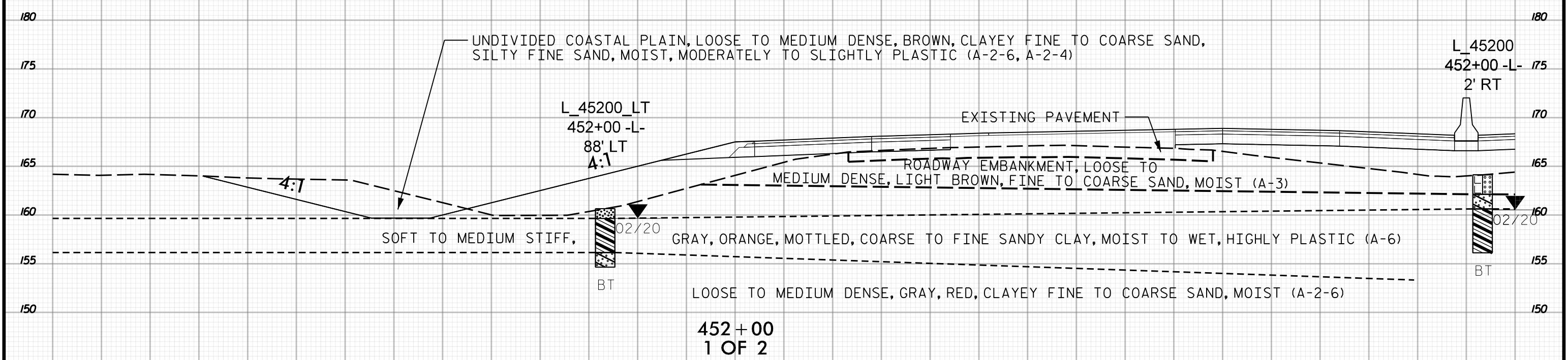
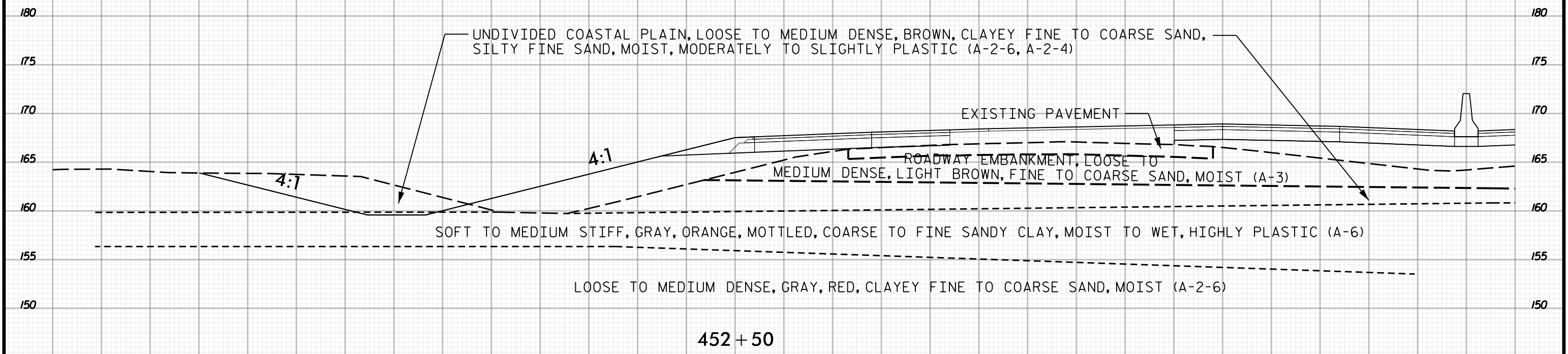

140 135 130 125 120 115 110 105 100 95 90 85 80 75 70 65 60 55 50 45 40 35 30 25 20 15 10 5 0 5



5 0 5 10 15 20 25 30 35 40 45 50 55 60 65 70 75 80 85 90 95 100 105 110 115 120 125 130 135 140 145

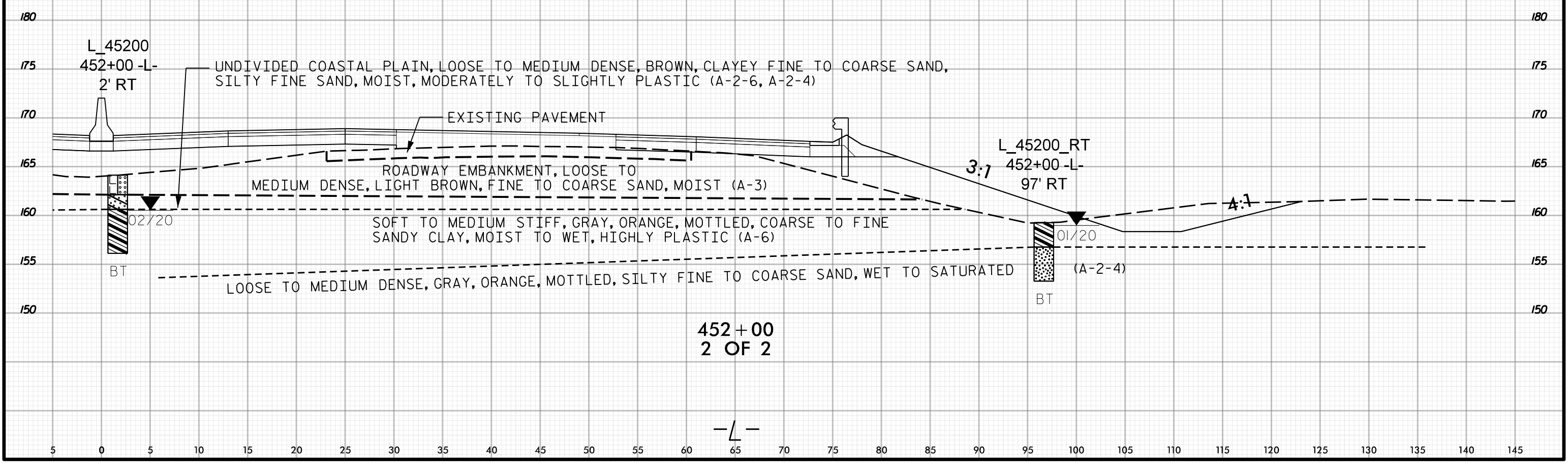
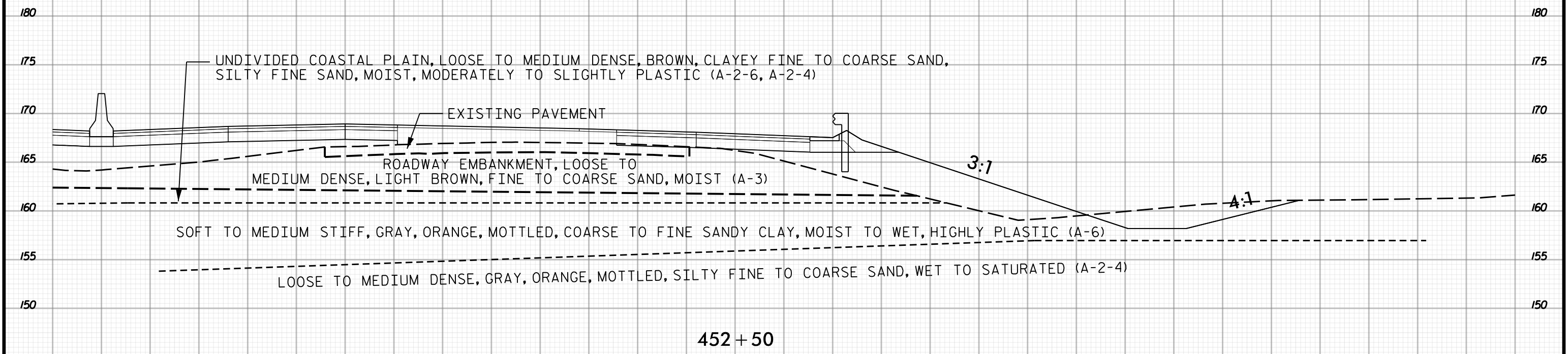

5 0 5 10 15 20 25 30 35 40 45 50 55 60 65 70 75 80 85 90 95 100 105 110 115 120 125 130 135 140 145



140 135 130 125 120 115 110 105 100 95 90 85 80 75 70 65 60 55 50 45 40 35 30 25 20 15 10 5 0 5

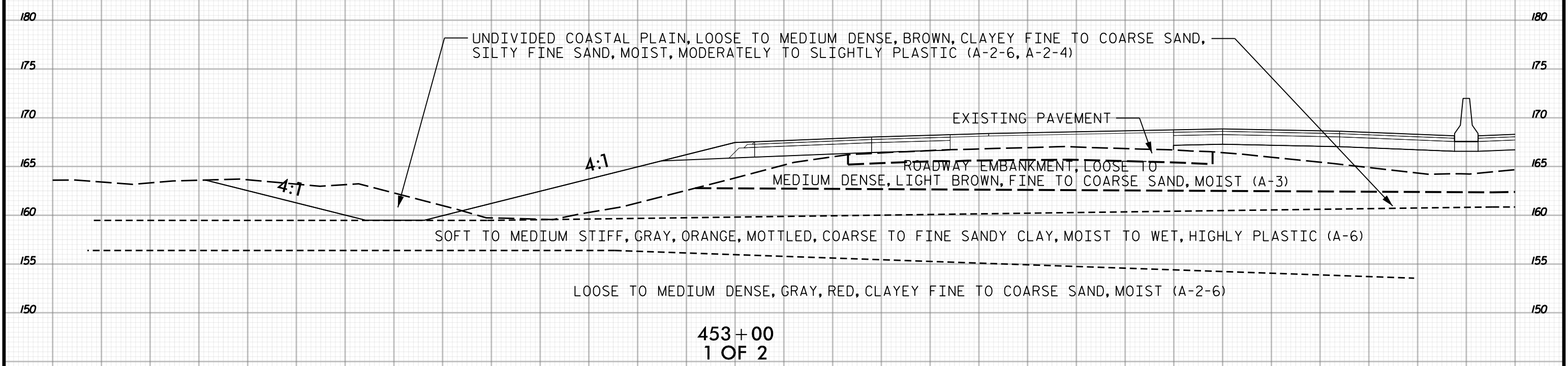
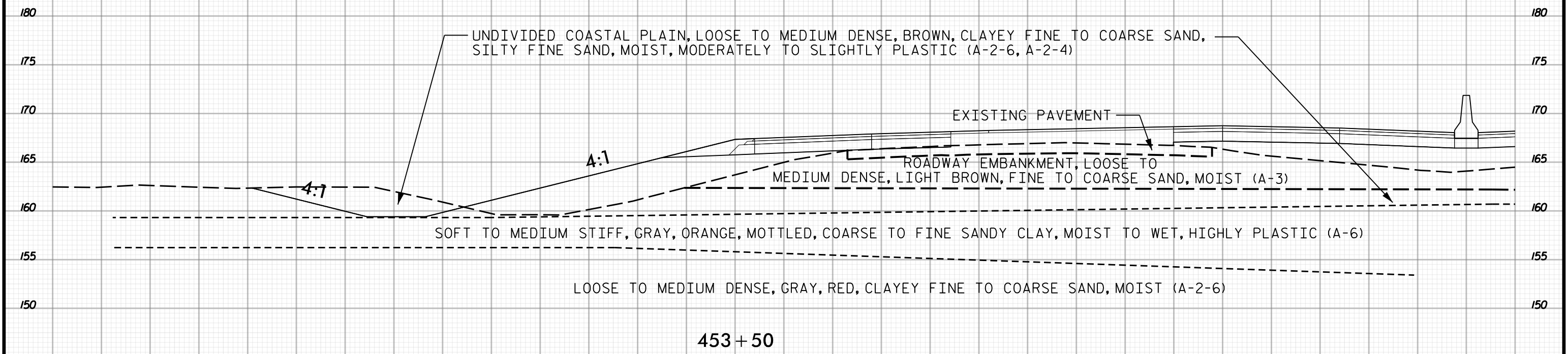

140 135 130 125 120 115 110 105 100 95 90 85 80 75 70 65 60 55 50 45 40 35 30 25 20 15 10 5 0 5

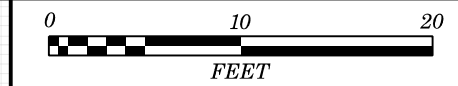

5 0 5 10 15 20 25 30 35 40 45 50 55 60 65 70 75 80 85 90 95 100 105 110 115 120 125 130 135 140 145

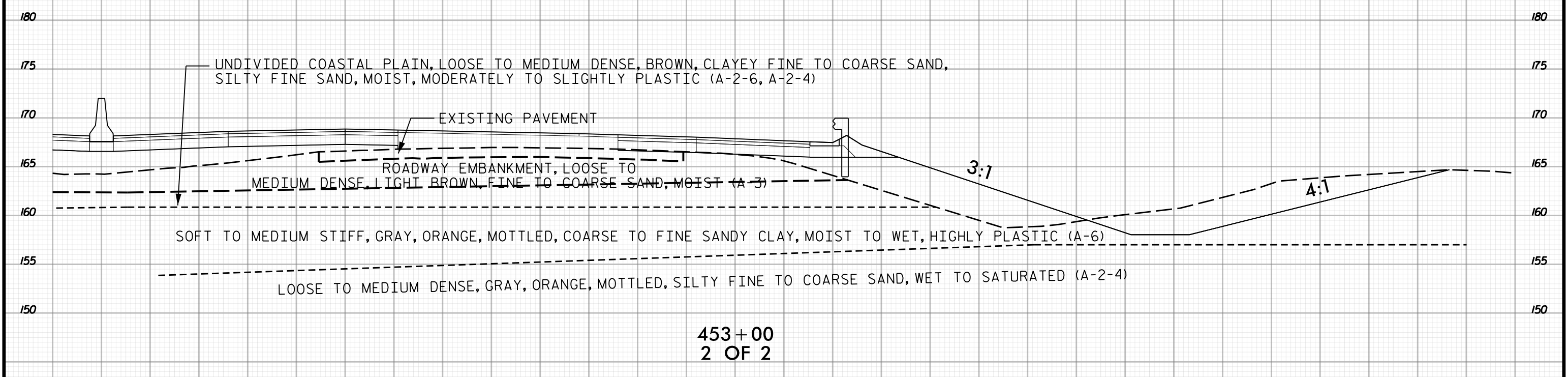
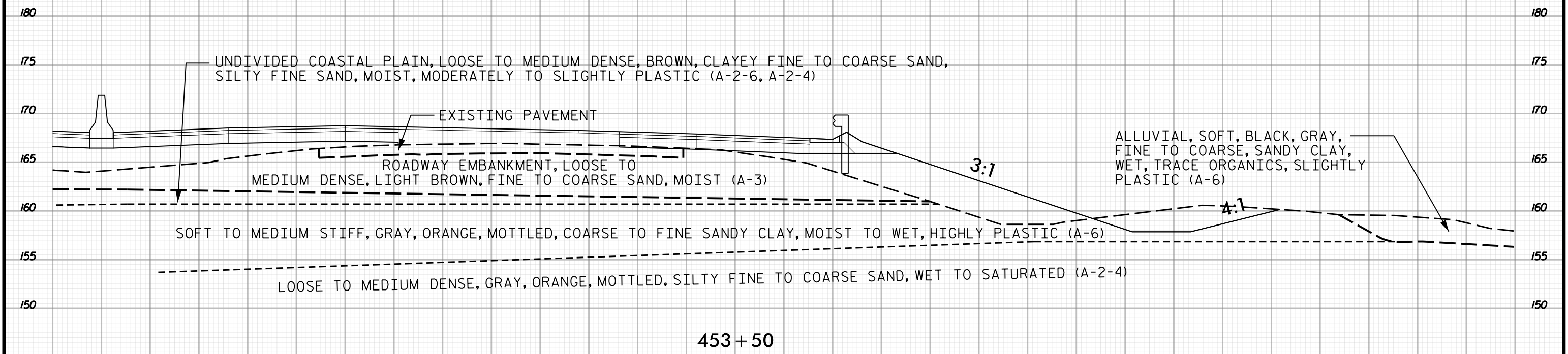

5 0 5 10 15 20 25 30 35 40 45 50 55 60 65 70 75 80 85 90 95 100 105 110 115 120 125 130 135 140 145



140 135 130 125 120 115 110 105 100 95 90 85 80 75 70 65 60 55 50 45 40 35 30 25 20 15 10 5 0 5

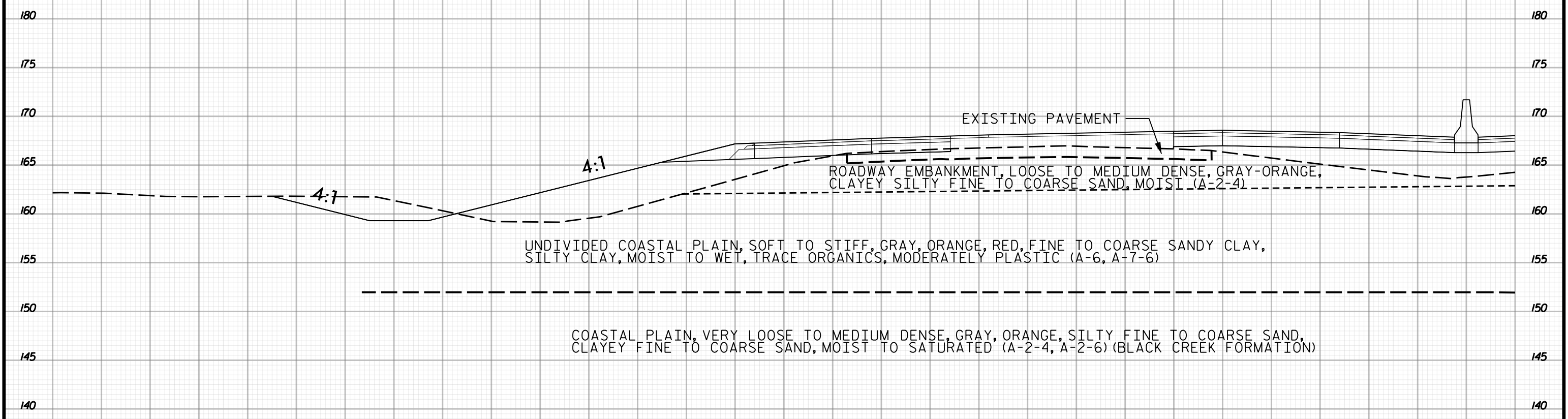

454+00
1 OF 2

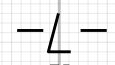

140 135 130 125 120 115 110 105 100 95 90 85 80 75 70 65 60 55 50 45 40 35 30 25 20 15 10 5 0 5



5 0 5 10 15 20 25 30 35 40 45 50 55 60 65 70 75 80 85 90 95 100 105 110 115 120 125 130 135 140 145

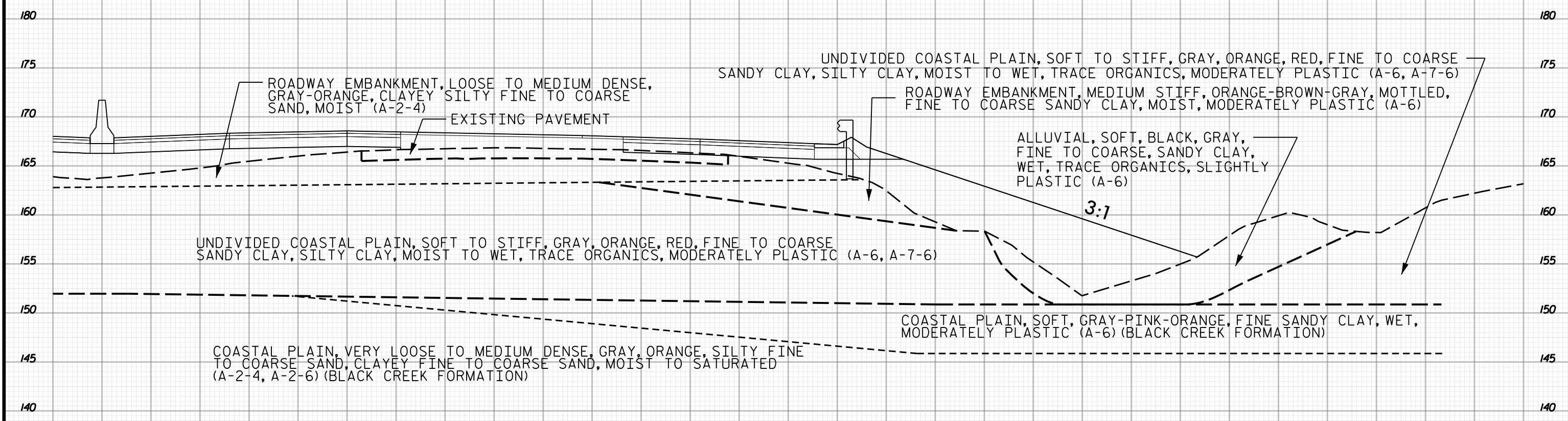

454+00
2 OF 2

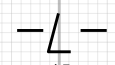

5 0 5 10 15 20 25 30 35 40 45 50 55 60 65 70 75 80 85 90 95 100 105 110 115 120 125 130 135 140 145

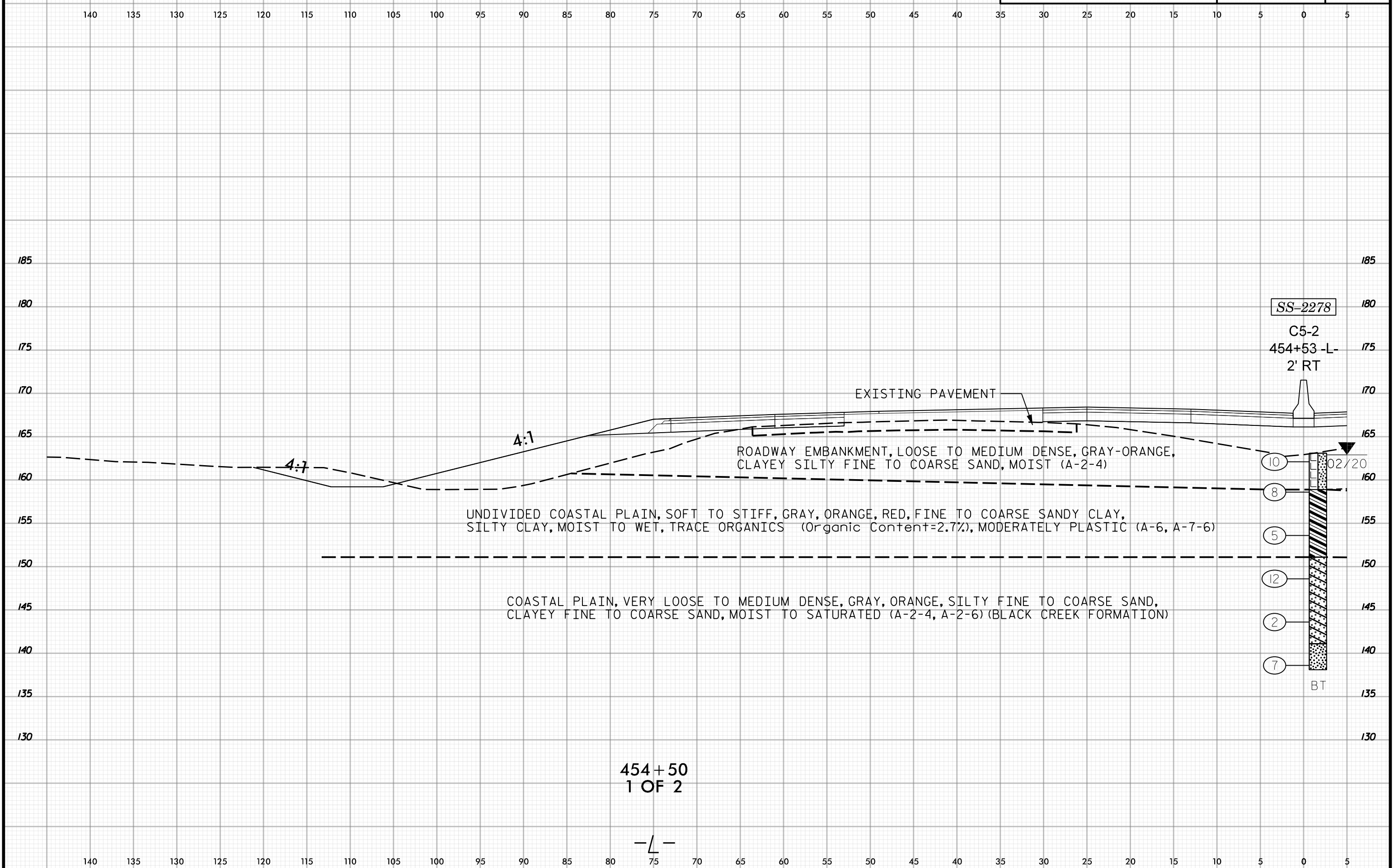



5 0 5 10 15 20 25 30 35 40 45 50 55 60 65 70 75 80 85 90 95 100 105 110 115 120 125 130 135 140 145

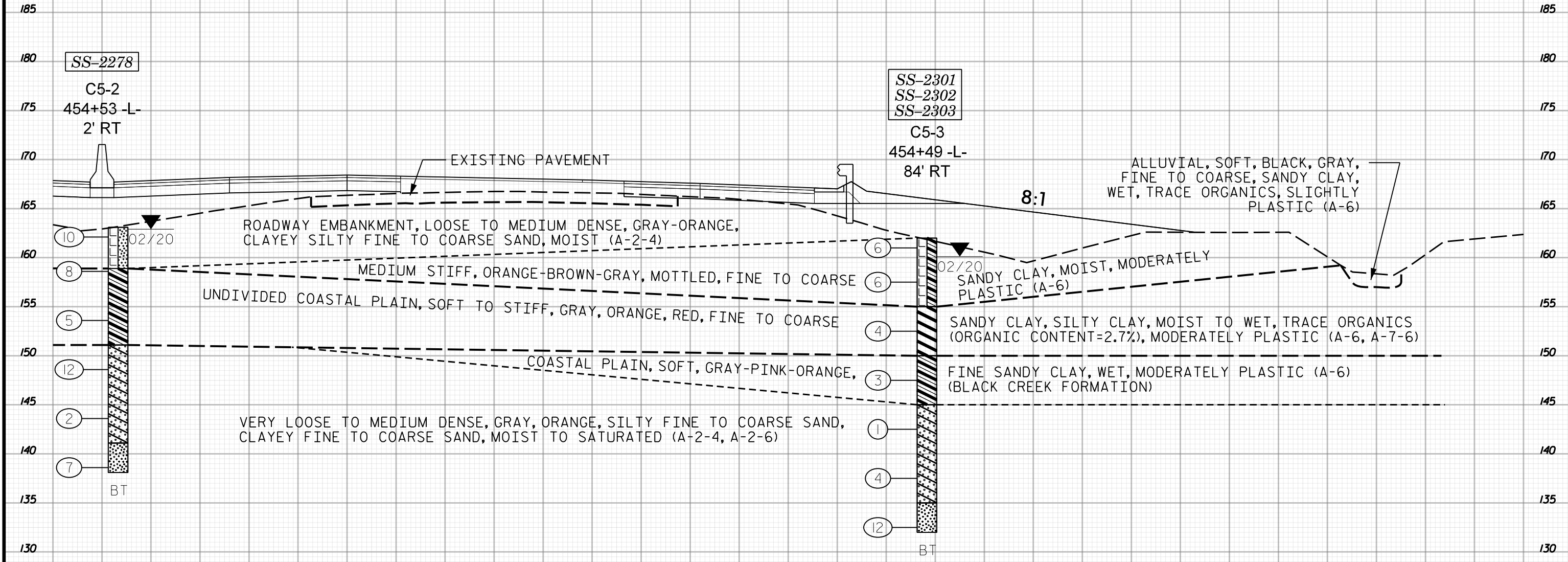

454+50
2 OF 2

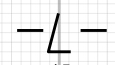

5 0 5 10 15 20 25 30 35 40 45 50 55 60 65 70 75 80 85 90 95 100 105 110 115 120 125 130 135 140 145

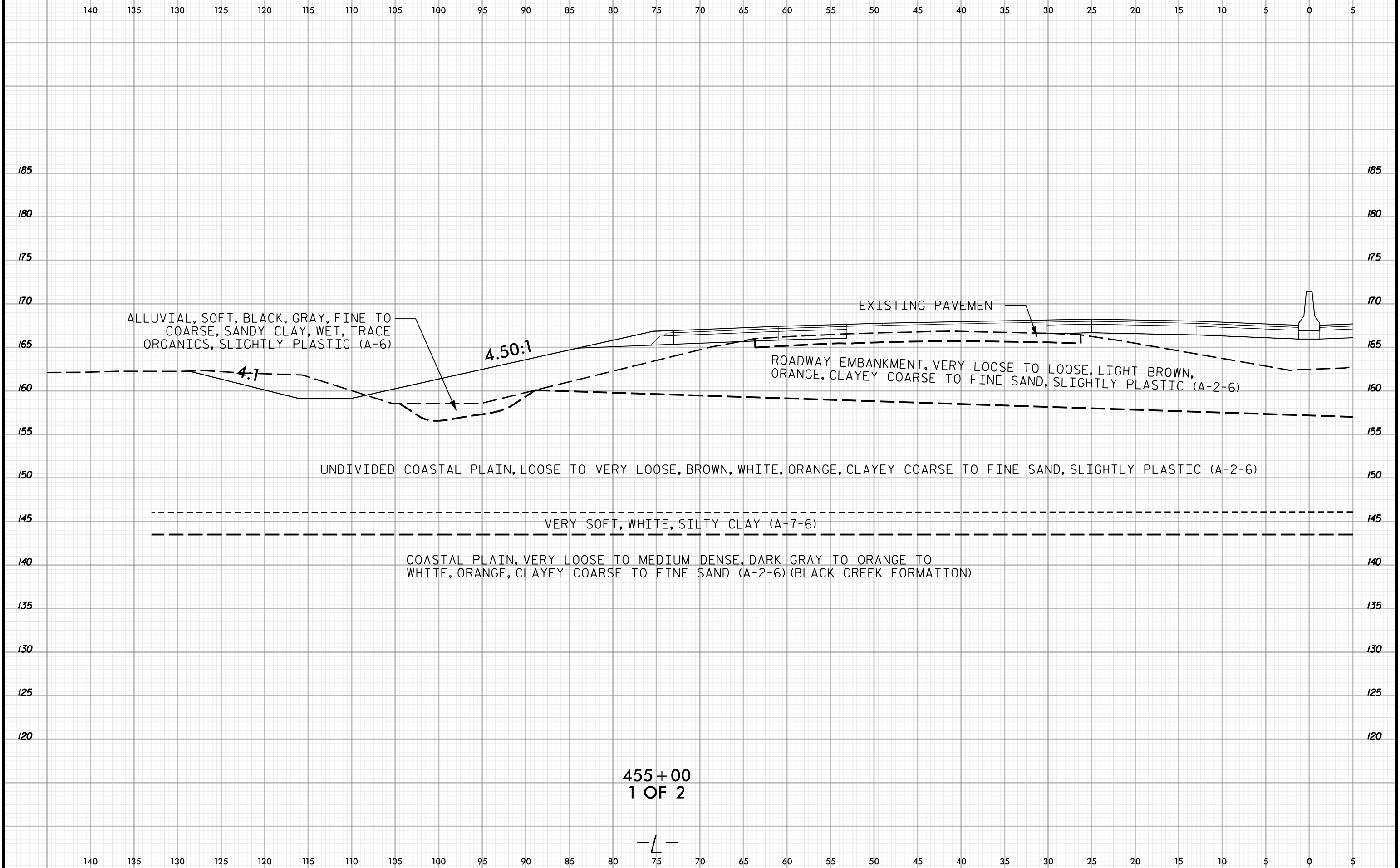

455+00
1 OF 2

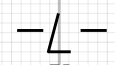

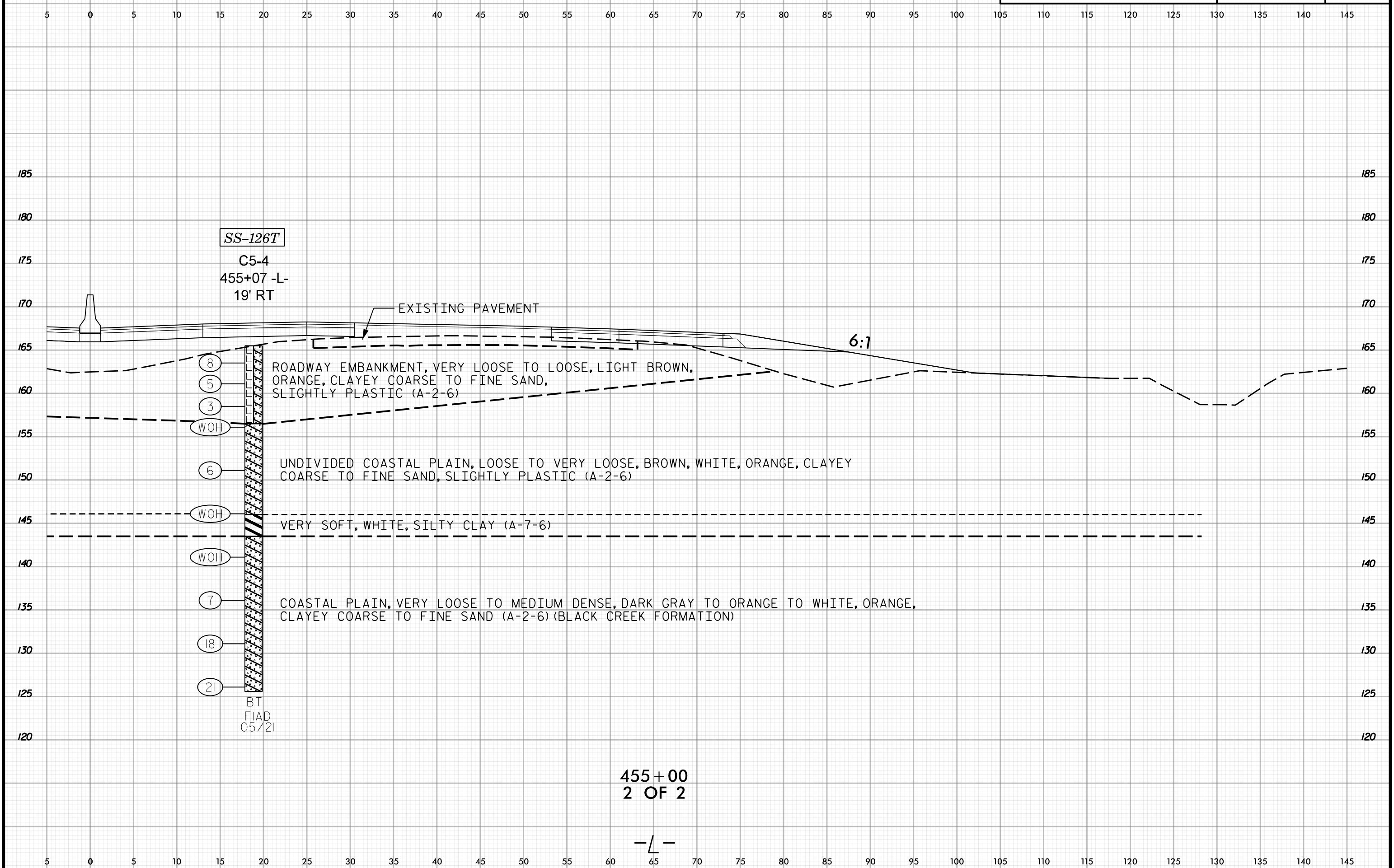

SS-126T

C5-4
455+07 -L-
19' RT

EXISTING PAVEMENT

6:1

8

5

3

WOH

6

WOH

WOH

7

18

21

BT
FIAD
05/21

ROADWAY EMBANKMENT, VERY LOOSE TO LOOSE, LIGHT BROWN, ORANGE, CLAYEY COARSE TO FINE SAND, SLIGHTLY PLASTIC (A-2-6)

UNDIVIDED COASTAL PLAIN, LOOSE TO VERY LOOSE, BROWN, WHITE, ORANGE, CLAYEY COARSE TO FINE SAND, SLIGHTLY PLASTIC (A-2-6)

VERY SOFT, WHITE, SILTY CLAY (A-7-6)

COASTAL PLAIN, VERY LOOSE TO MEDIUM DENSE, DARK GRAY TO ORANGE TO WHITE, ORANGE, CLAYEY COARSE TO FINE SAND (A-2-6) (BLACK CREEK FORMATION)

455+00
2 OF 2

-L-

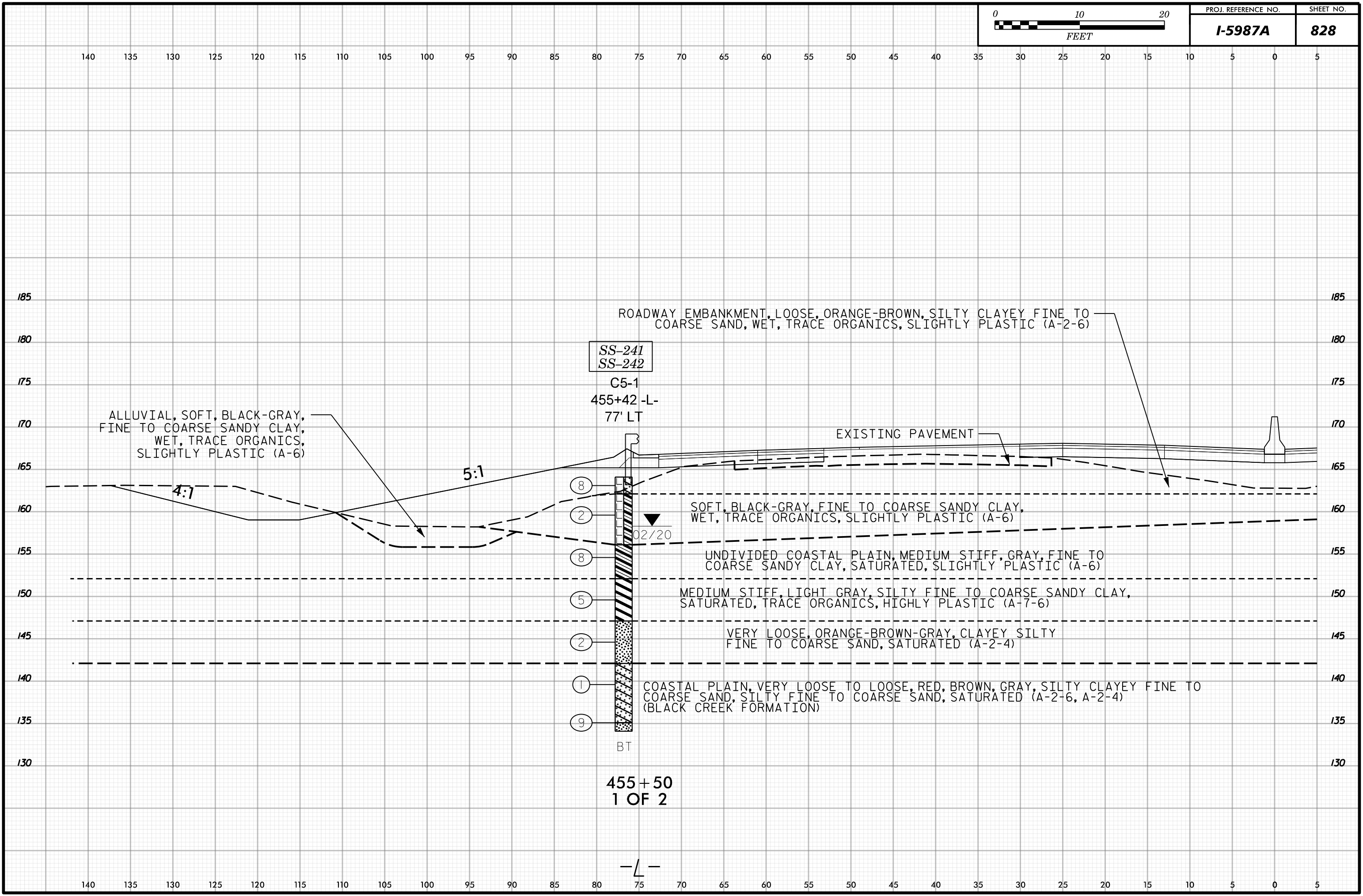

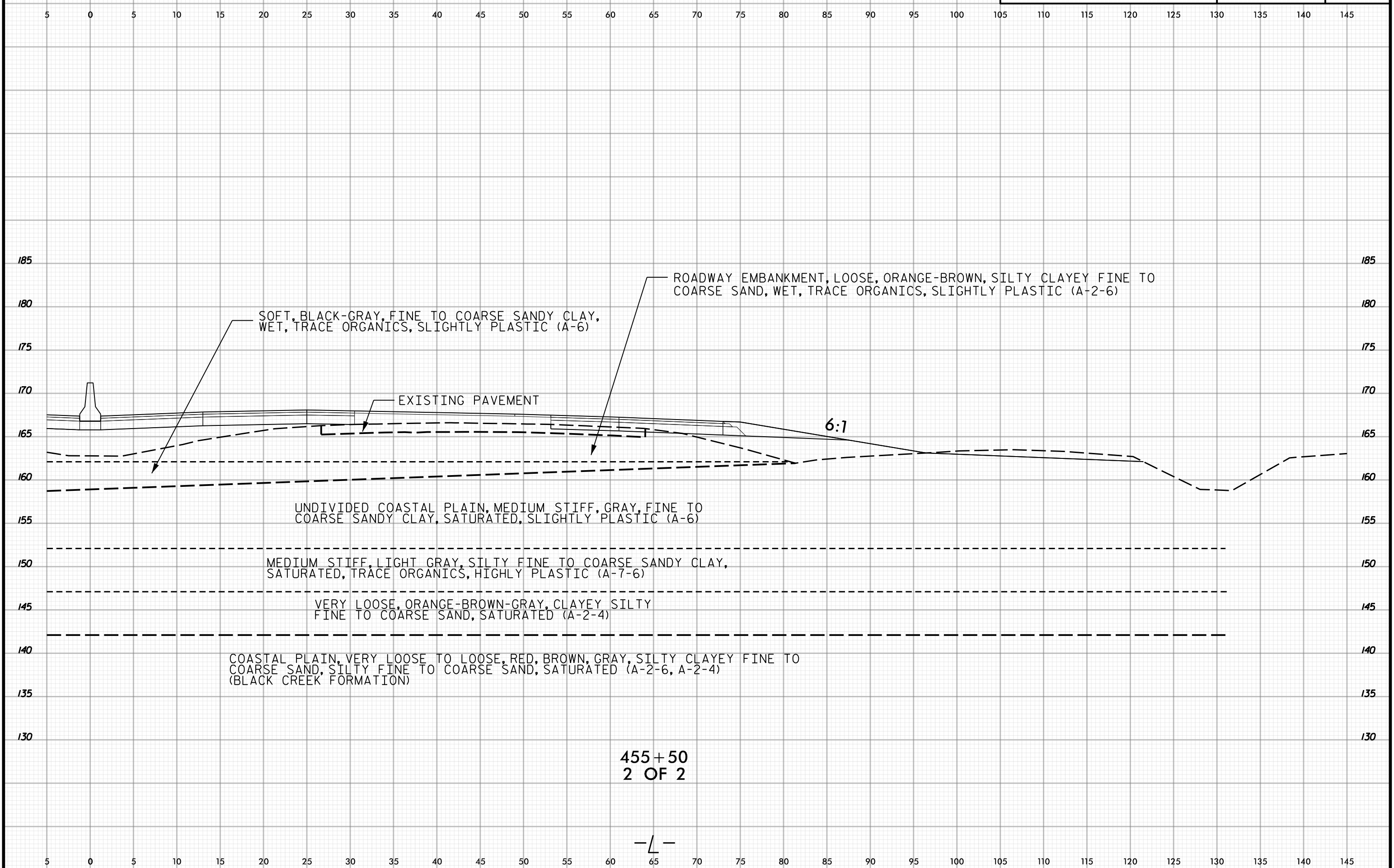

SOFT, BLACK-GRAY, FINE TO COARSE SANDY CLAY, WET, TRACE ORGANICS, SLIGHTLY PLASTIC (A-6)

ROADWAY EMBANKMENT, LOOSE, ORANGE-BROWN, SILTY CLAYEY FINE TO COARSE SAND, WET, TRACE ORGANICS, SLIGHTLY PLASTIC (A-2-6)

EXISTING PAVEMENT

6:1

UNDIVIDED COASTAL PLAIN, MEDIUM STIFF, GRAY, FINE TO COARSE SANDY CLAY, SATURATED, SLIGHTLY PLASTIC (A-6)

MEDIUM STIFF, LIGHT GRAY, SILTY FINE TO COARSE SANDY CLAY, SATURATED, TRACE ORGANICS, HIGHLY PLASTIC (A-7-6)

VERY LOOSE, ORANGE-BROWN-GRAY, CLAYEY SILTY FINE TO COARSE SAND, SATURATED (A-2-4)

COASTAL PLAIN, VERY LOOSE TO LOOSE, RED, BROWN, GRAY, SILTY CLAYEY FINE TO COARSE SAND, SILTY FINE TO COARSE SAND, SATURATED (A-2-6, A-2-4) (BLACK CREEK FORMATION)

455 + 50
2 OF 2

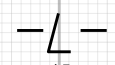



140 135 130 125 120 115 110 105 100 95 90 85 80 75 70 65 60 55 50 45 40 35 30 25 20 15 10 5 0 5

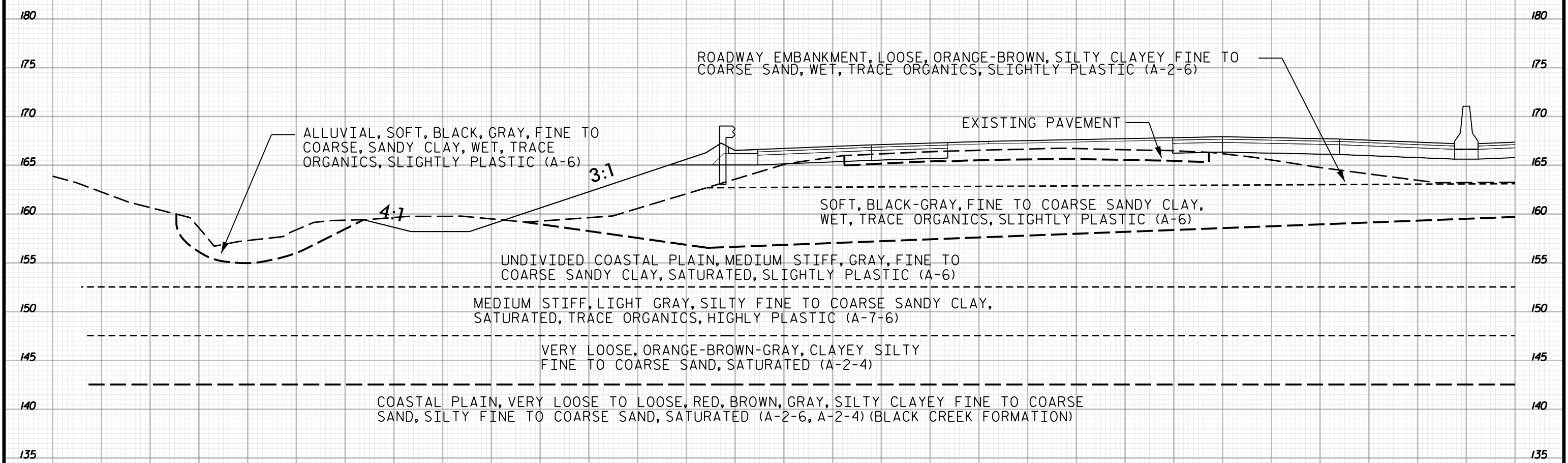

456+00
1 OF 2

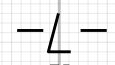

140 135 130 125 120 115 110 105 100 95 90 85 80 75 70 65 60 55 50 45 40 35 30 25 20 15 10 5 0 5



5 0 5 10 15 20 25 30 35 40 45 50 55 60 65 70 75 80 85 90 95 100 105 110 115 120 125 130 135 140 145

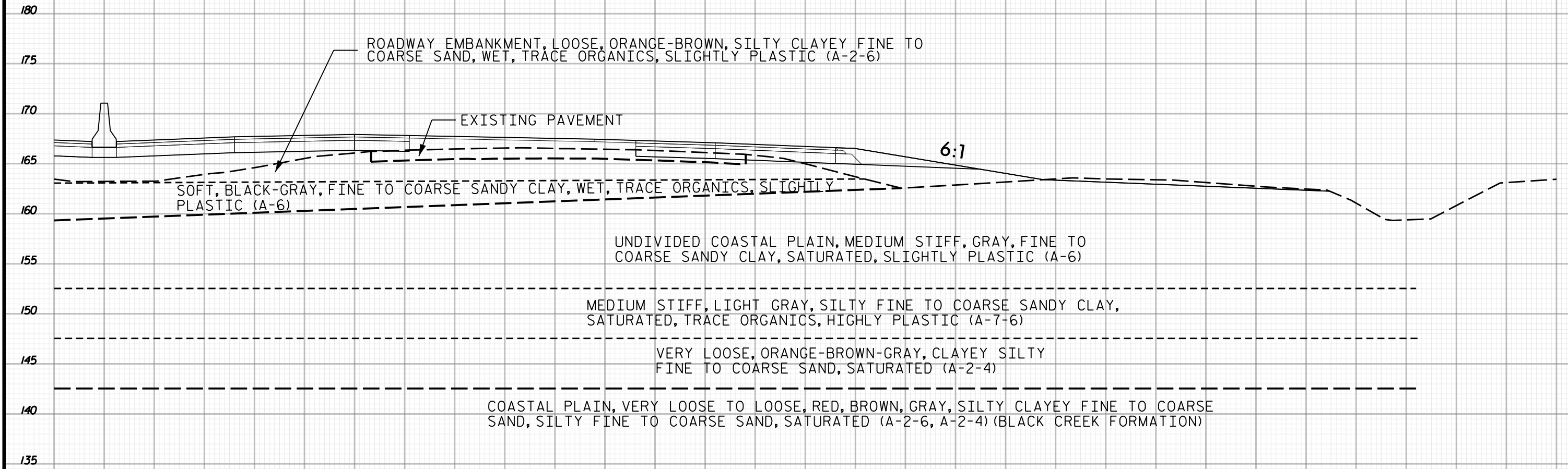

456+00
2 OF 2

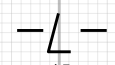

5 0 5 10 15 20 25 30 35 40 45 50 55 60 65 70 75 80 85 90 95 100 105 110 115 120 125 130 135 140 145



140 135 130 125 120 115 110 105 100 95 90 85 80 75 70 65 60 55 50 45 40 35 30 25 20 15 10 5 0 5

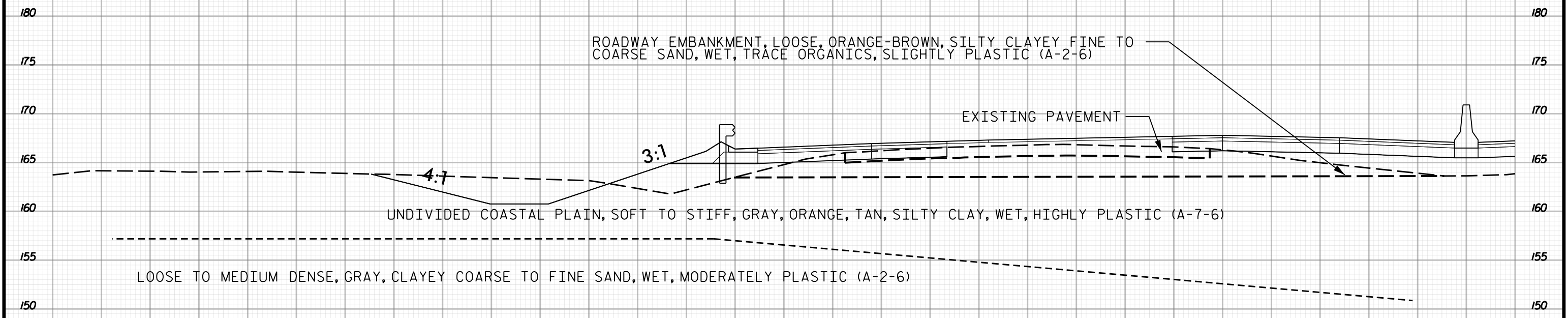

457+00

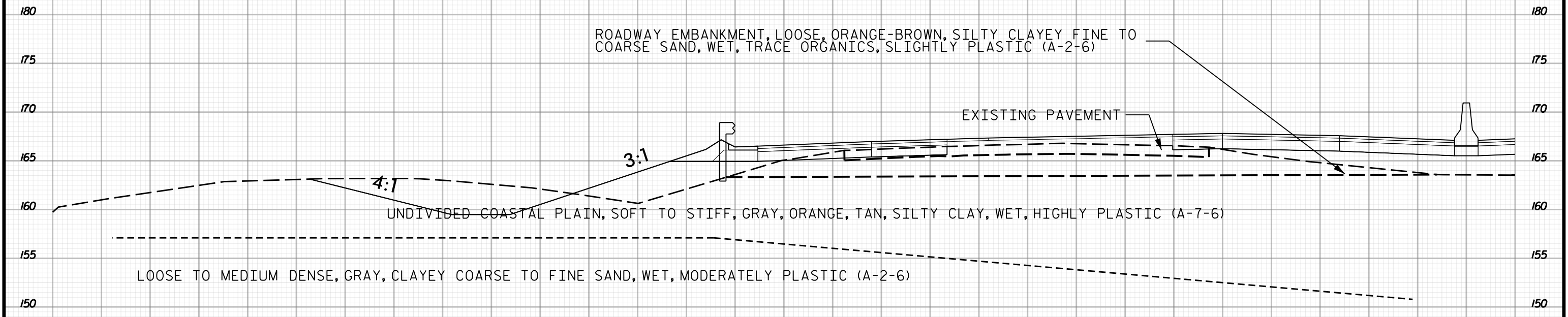

456+50
1 OF 2

140 135 130 125 120 115 110 105 100 95 90 85 80 75 70 65 60 55 50 45 40 35 30 25 20 15 10 5 0 5

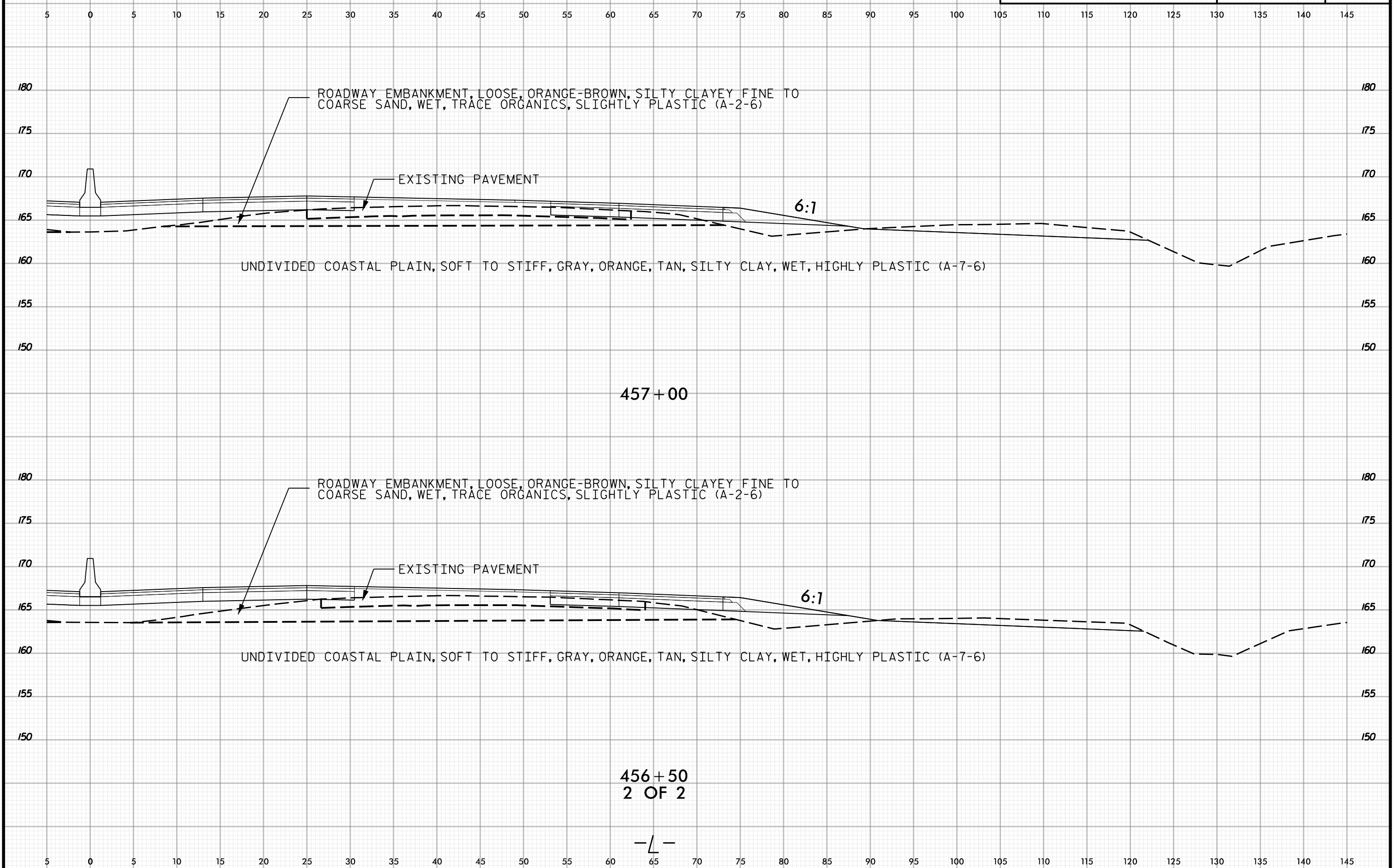

457+00

456+50
2 OF 2

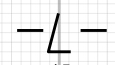



140 135 130 125 120 115 110 105 100 95 90 85 80 75 70 65 60 55 50 45 40 35 30 25 20 15 10 5 0 5

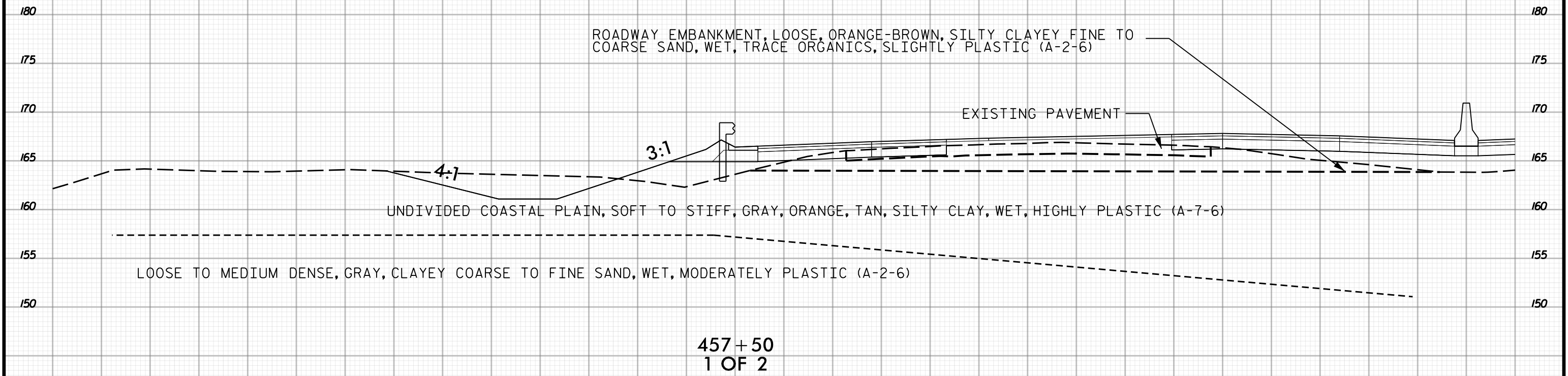
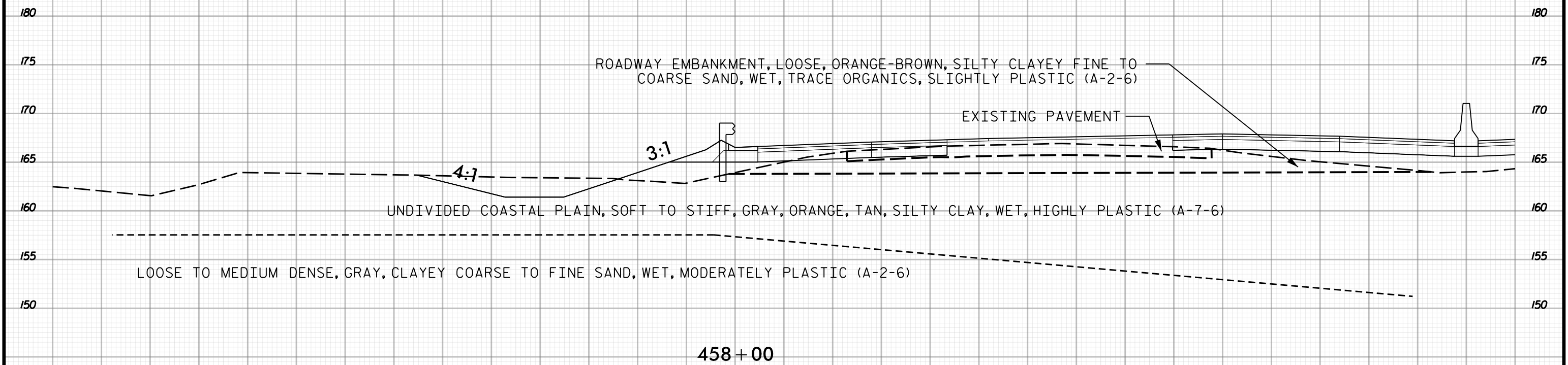

140 135 130 125 120 115 110 105 100 95 90 85 80 75 70 65 60 55 50 45 40 35 30 25 20 15 10 5 0 5

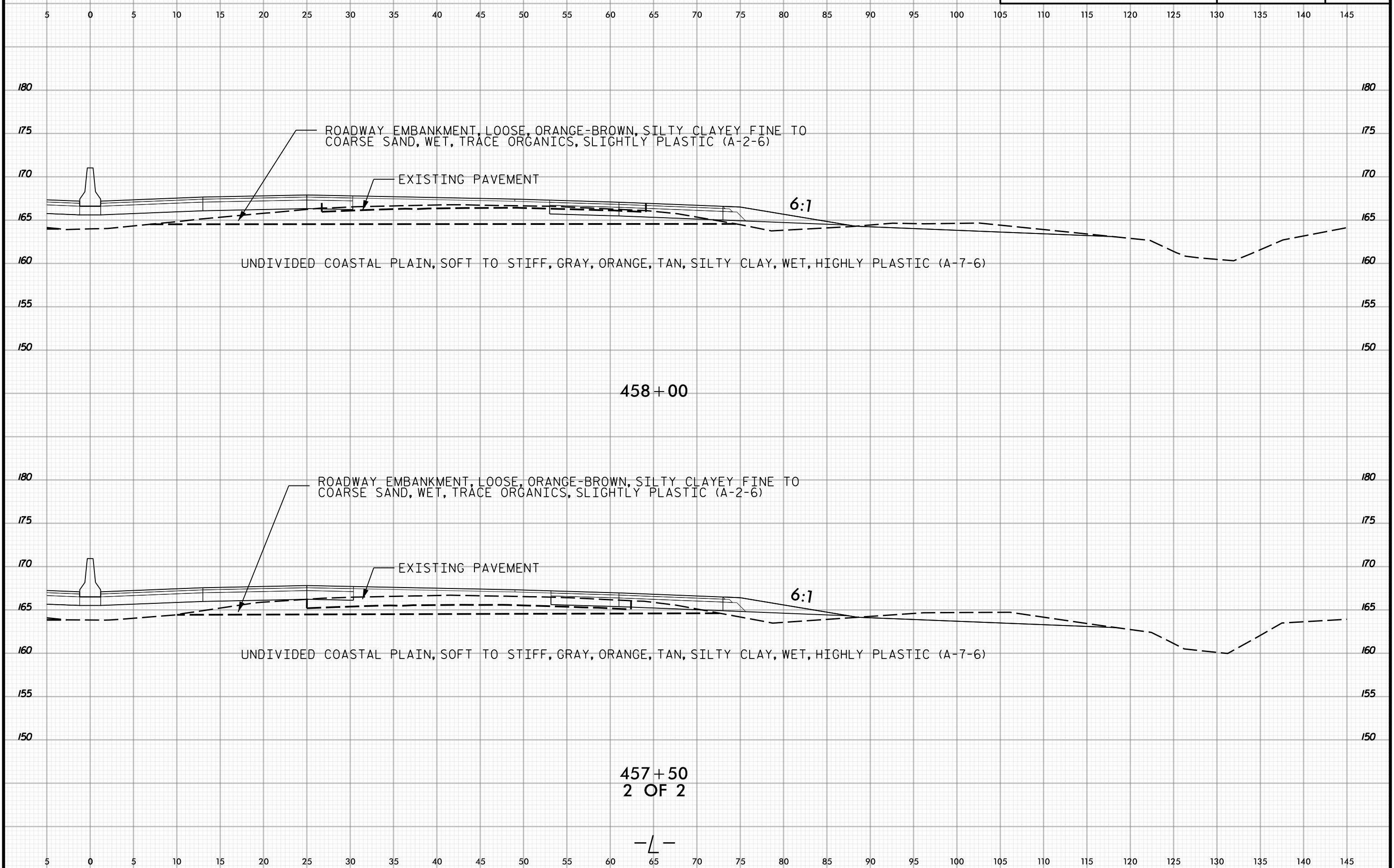

ROADWAY EMBANKMENT, LOOSE, ORANGE-BROWN, SILTY CLAYEY FINE TO COARSE SAND, WET, TRACE ORGANICS, SLIGHTLY PLASTIC (A-2-6)

EXISTING PAVEMENT

6:1

UNDIVIDED COASTAL PLAIN, SOFT TO STIFF, GRAY, ORANGE, TAN, SILTY CLAY, WET, HIGHLY PLASTIC (A-7-6)

458+00

ROADWAY EMBANKMENT, LOOSE, ORANGE-BROWN, SILTY CLAYEY FINE TO COARSE SAND, WET, TRACE ORGANICS, SLIGHTLY PLASTIC (A-2-6)

EXISTING PAVEMENT

6:1

UNDIVIDED COASTAL PLAIN, SOFT TO STIFF, GRAY, ORANGE, TAN, SILTY CLAY, WET, HIGHLY PLASTIC (A-7-6)

457+50
2 OF 2

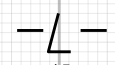



140 135 130 125 120 115 110 105 100 95 90 85 80 75 70 65 60 55 50 45 40 35 30 25 20 15 10 5 0 5

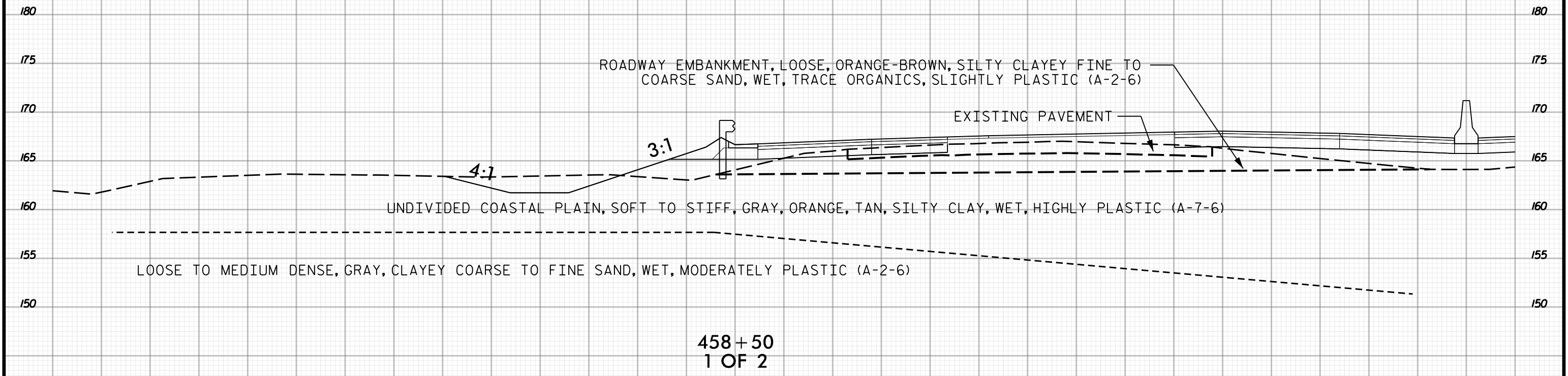
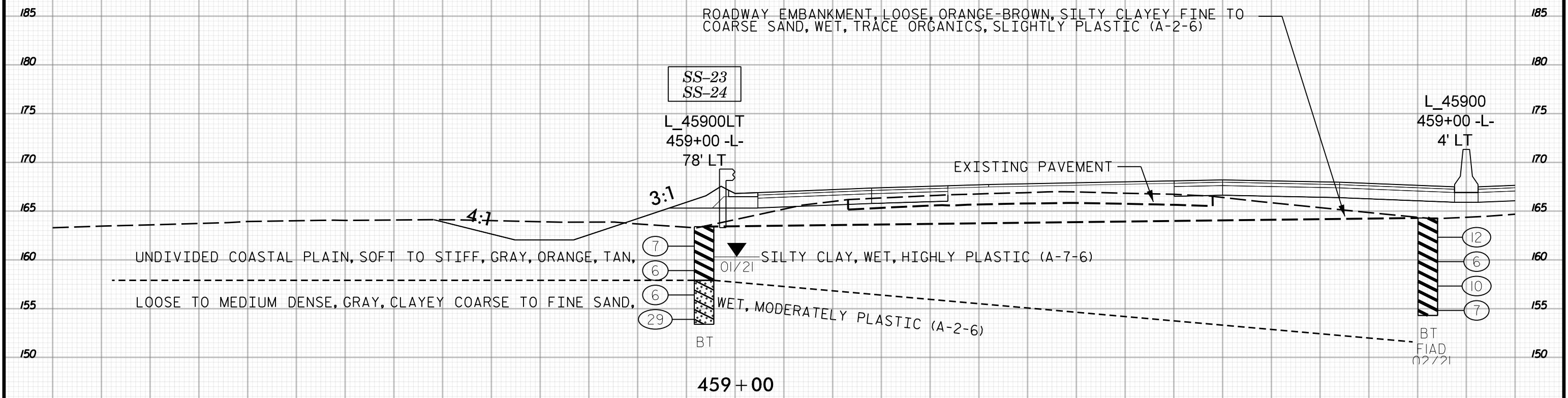

140 135 130 125 120 115 110 105 100 95 90 85 80 75 70 65 60 55 50 45 40 35 30 25 20 15 10 5 0 5

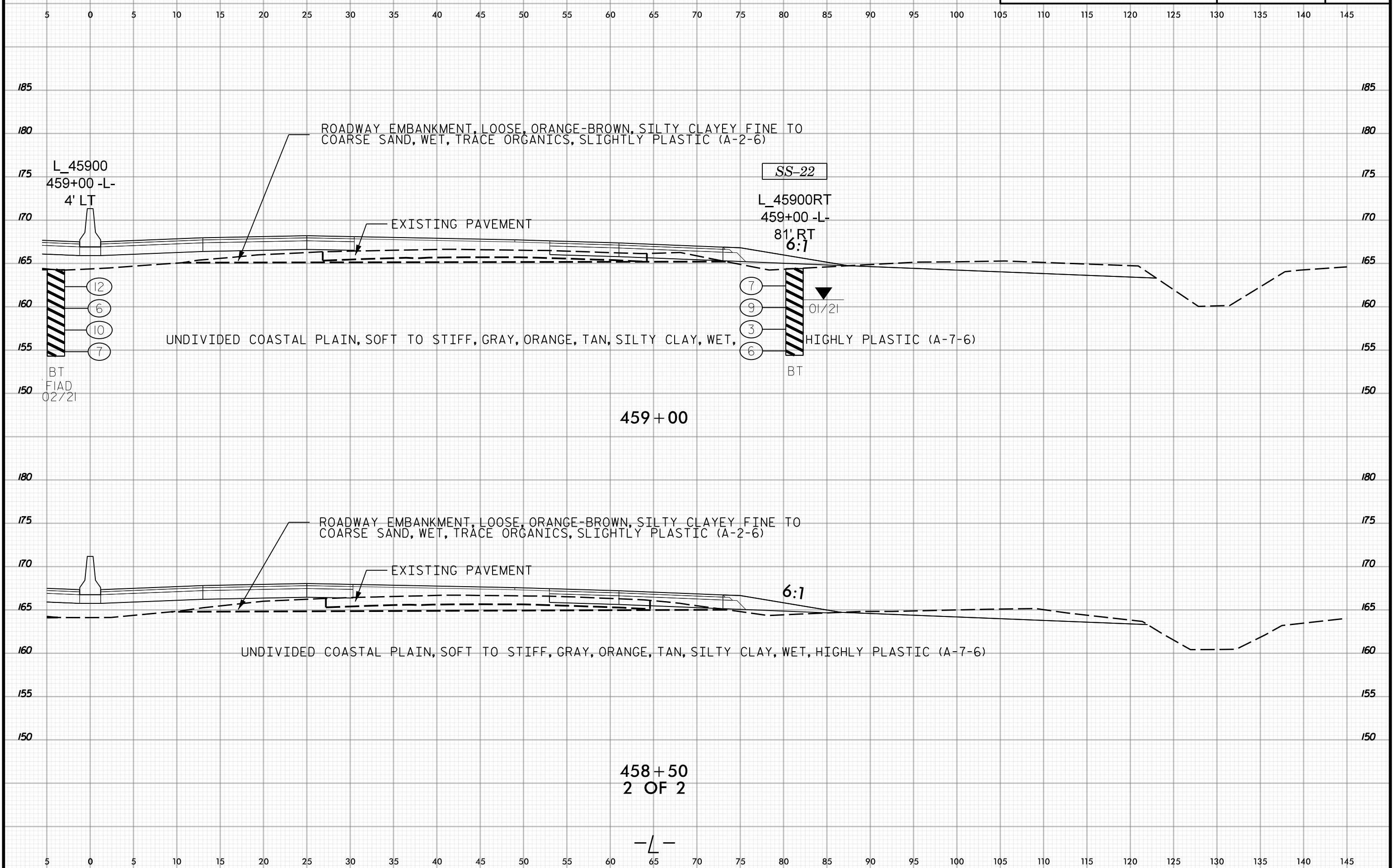



140 135 130 125 120 115 110 105 100 95 90 85 80 75 70 65 60 55 50 45 40 35 30 25 20 15 10 5 0 5

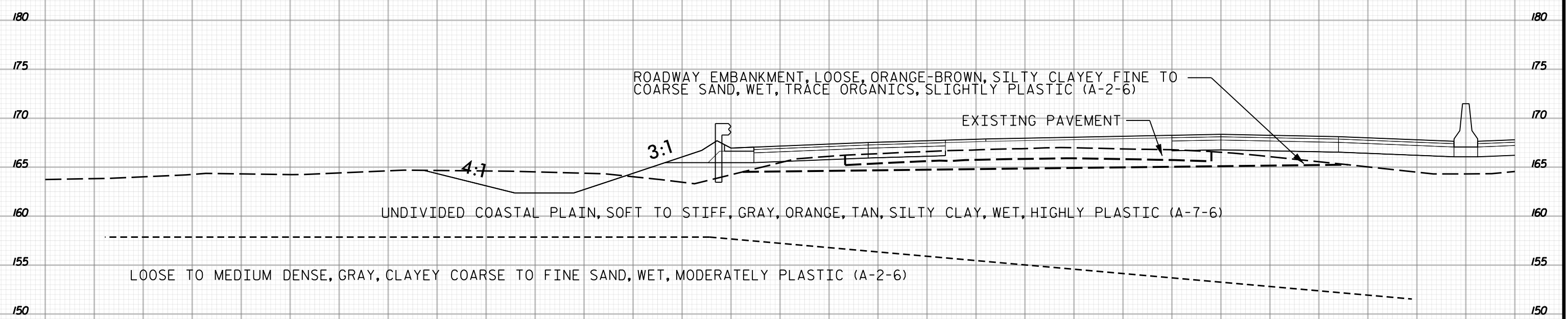
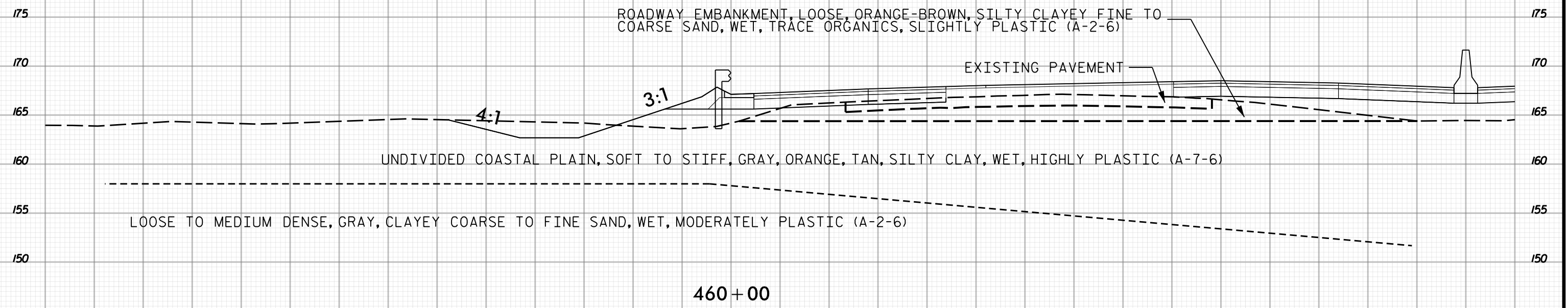

1 OF 2

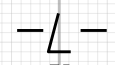

140 135 130 125 120 115 110 105 100 95 90 85 80 75 70 65 60 55 50 45 40 35 30 25 20 15 10 5 0 5



PROJ. REFERENCE NO.	SHEET NO.
I-5987A	839

5 0 5 10 15 20 25 30 35 40 45 50 55 60 65 70 75 80 85 90 95 100 105 110 115 120 125 130 135 140 145

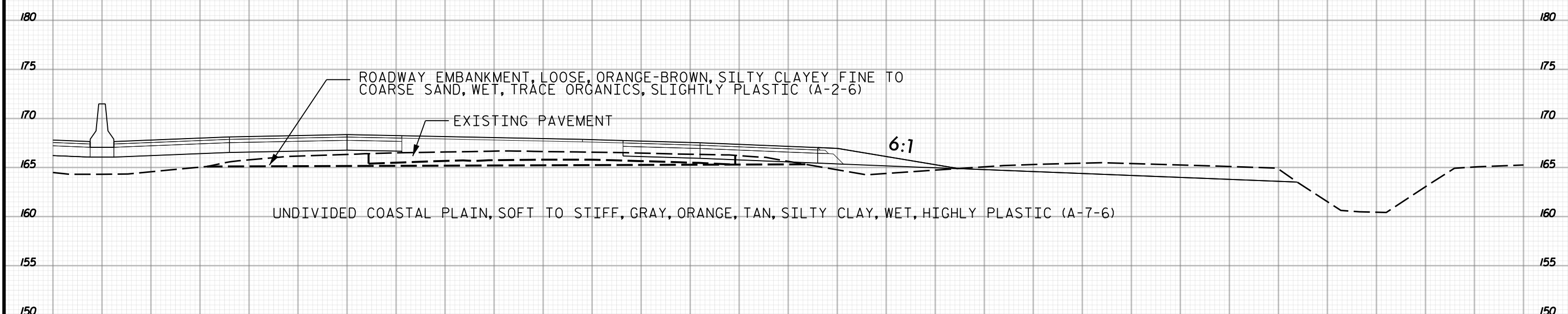
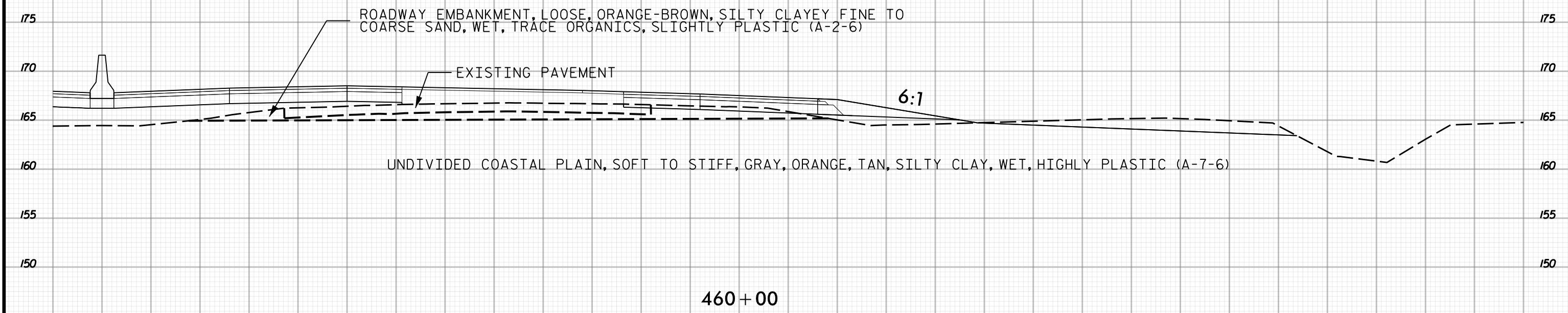

459+50
2 OF 2

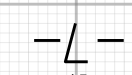

5 0 5 10 15 20 25 30 35 40 45 50 55 60 65 70 75 80 85 90 95 100 105 110 115 120 125 130 135 140 145



140 135 130 125 120 115 110 105 100 95 90 85 80 75 70 65 60 55 50 45 40 35 30 25 20 15 10 5 0 5

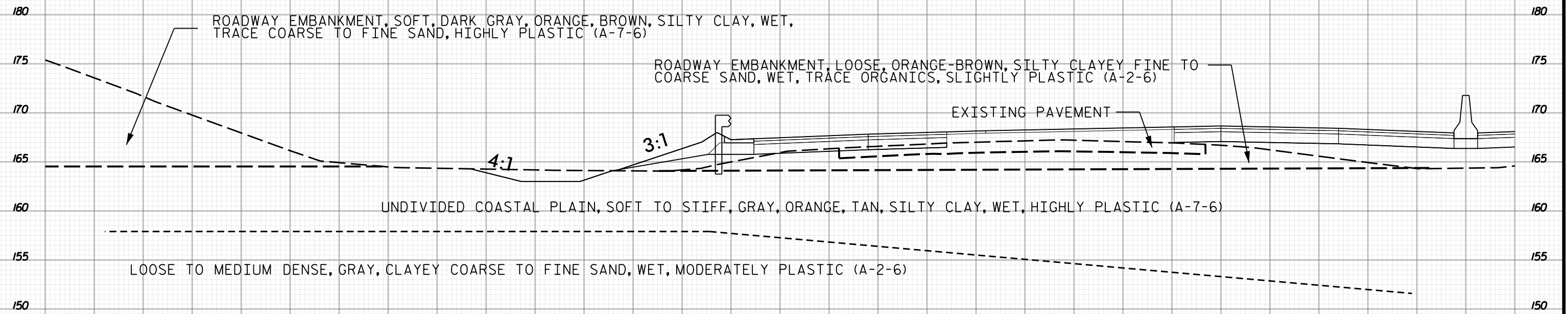

460 + 50
1 OF 2

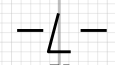

140 135 130 125 120 115 110 105 100 95 90 85 80 75 70 65 60 55 50 45 40 35 30 25 20 15 10 5 0 5

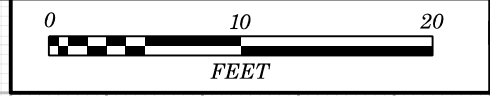

PROJ. REFERENCE NO.	SHEET NO.
I-5987A	841

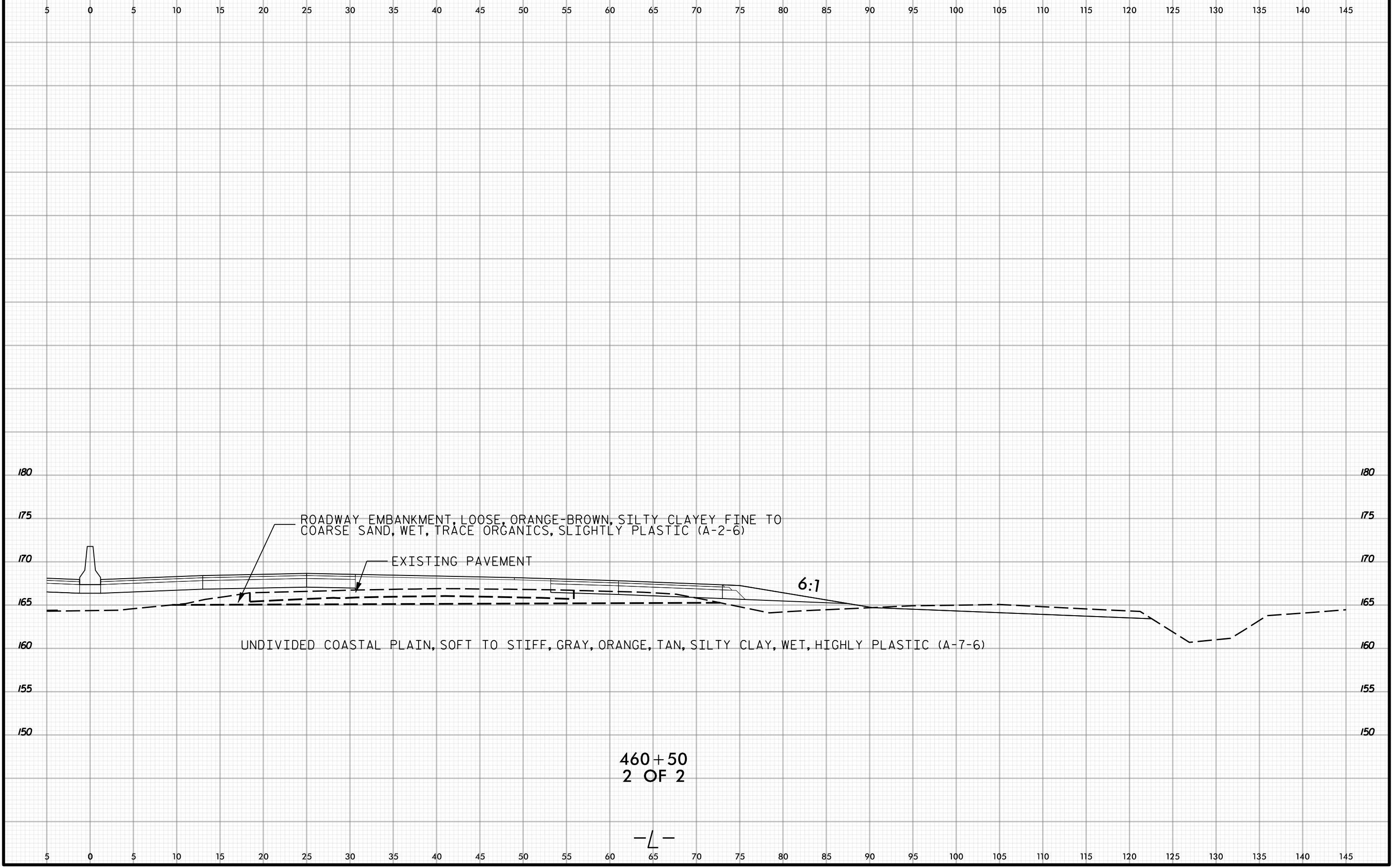

460+50
2 OF 2

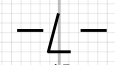

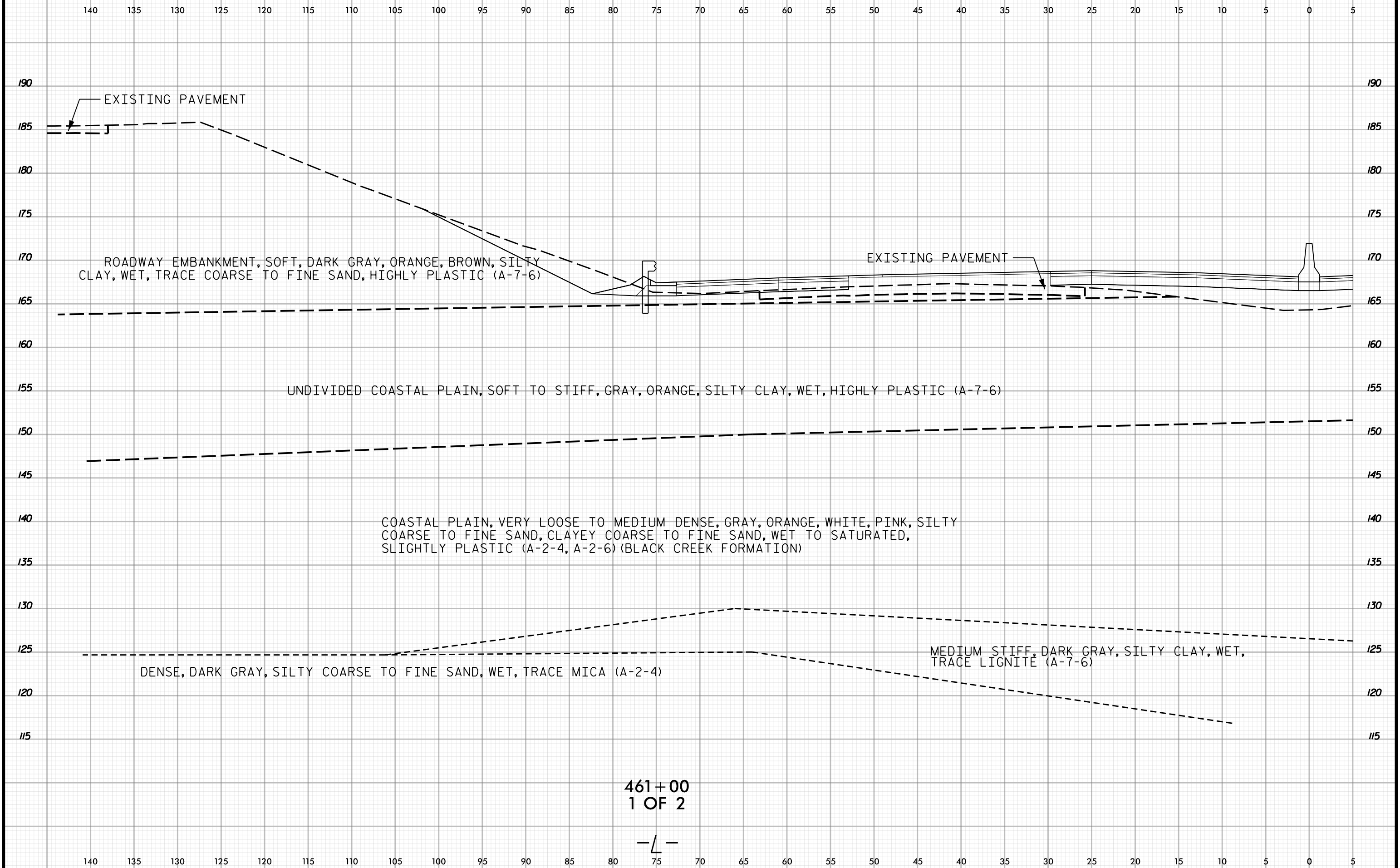

461+00
1 OF 2

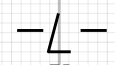

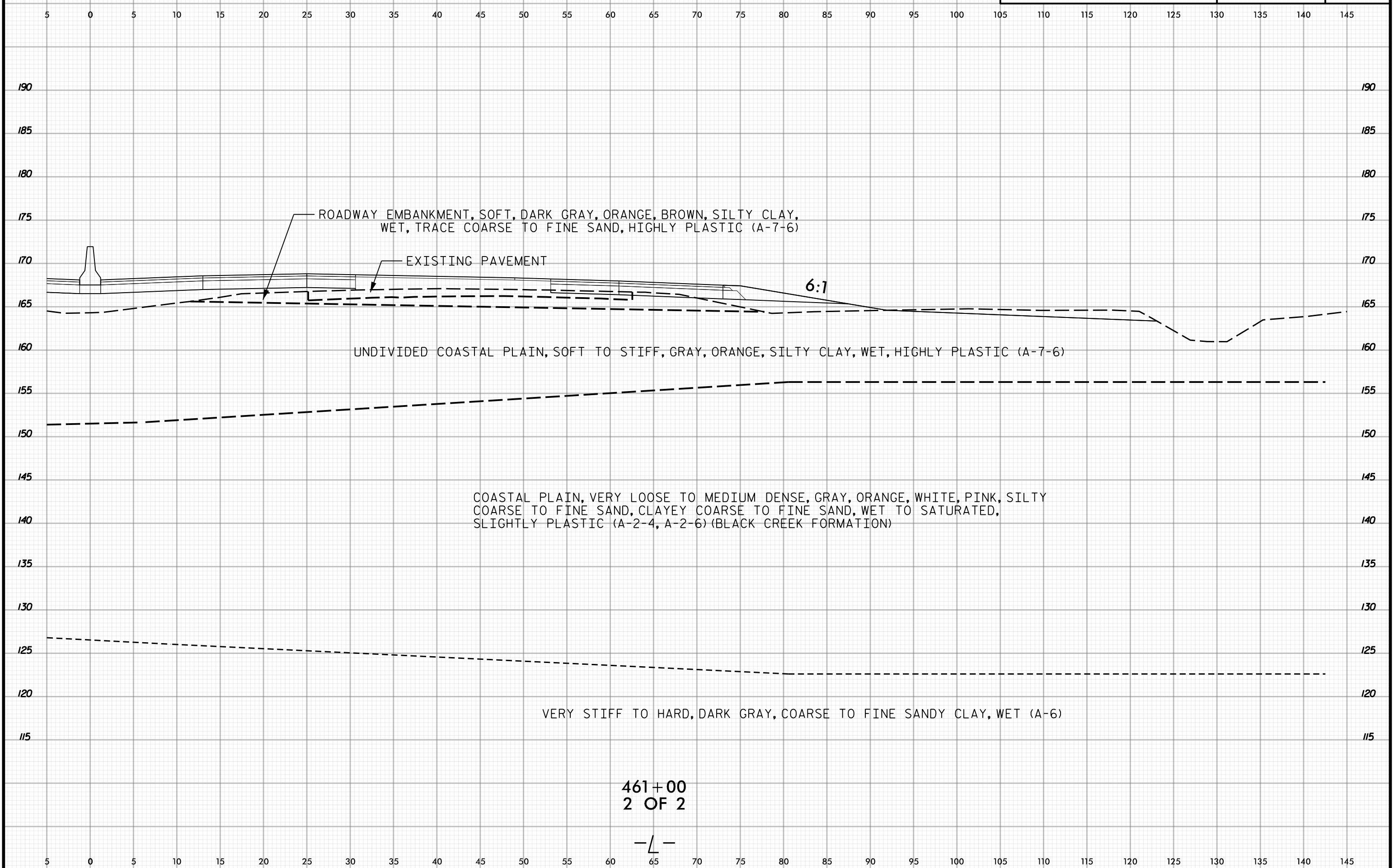

ROADWAY EMBANKMENT, SOFT, DARK GRAY, ORANGE, BROWN, SILTY CLAY, WET, TRACE COARSE TO FINE SAND, HIGHLY PLASTIC (A-7-6)

EXISTING PAVEMENT

6:1

UNDIVIDED COASTAL PLAIN, SOFT TO STIFF, GRAY, ORANGE, SILTY CLAY, WET, HIGHLY PLASTIC (A-7-6)

COASTAL PLAIN, VERY LOOSE TO MEDIUM DENSE, GRAY, ORANGE, WHITE, PINK, SILTY COARSE TO FINE SAND, CLAYEY COARSE TO FINE SAND, WET TO SATURATED, SLIGHTLY PLASTIC (A-2-4, A-2-6) (BLACK CREEK FORMATION)

VERY STIFF TO HARD, DARK GRAY, COARSE TO FINE SANDY CLAY, WET (A-6)

461+00
2 OF 2

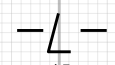

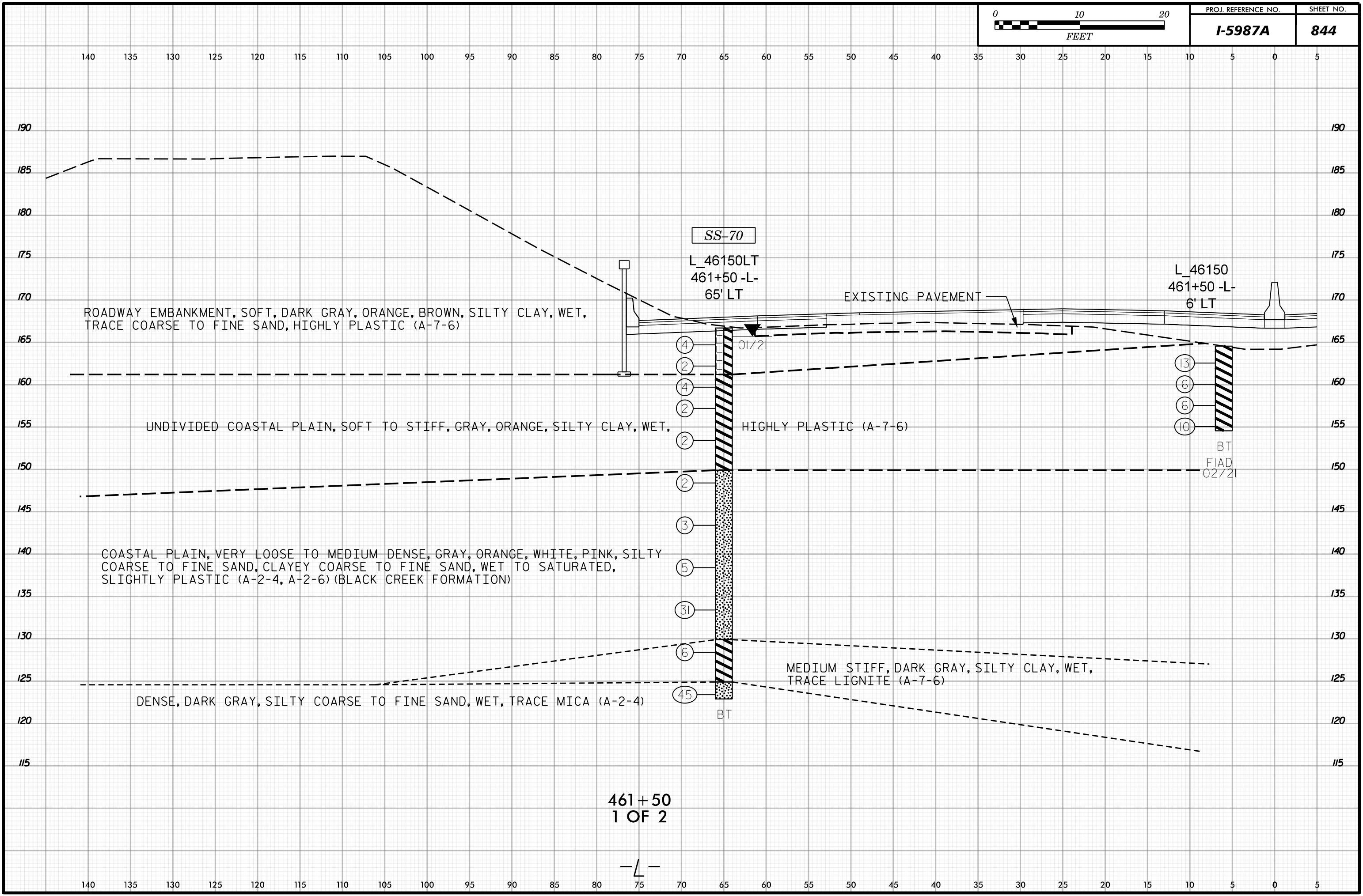
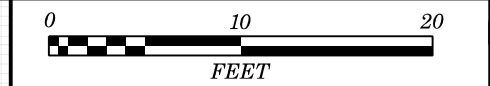

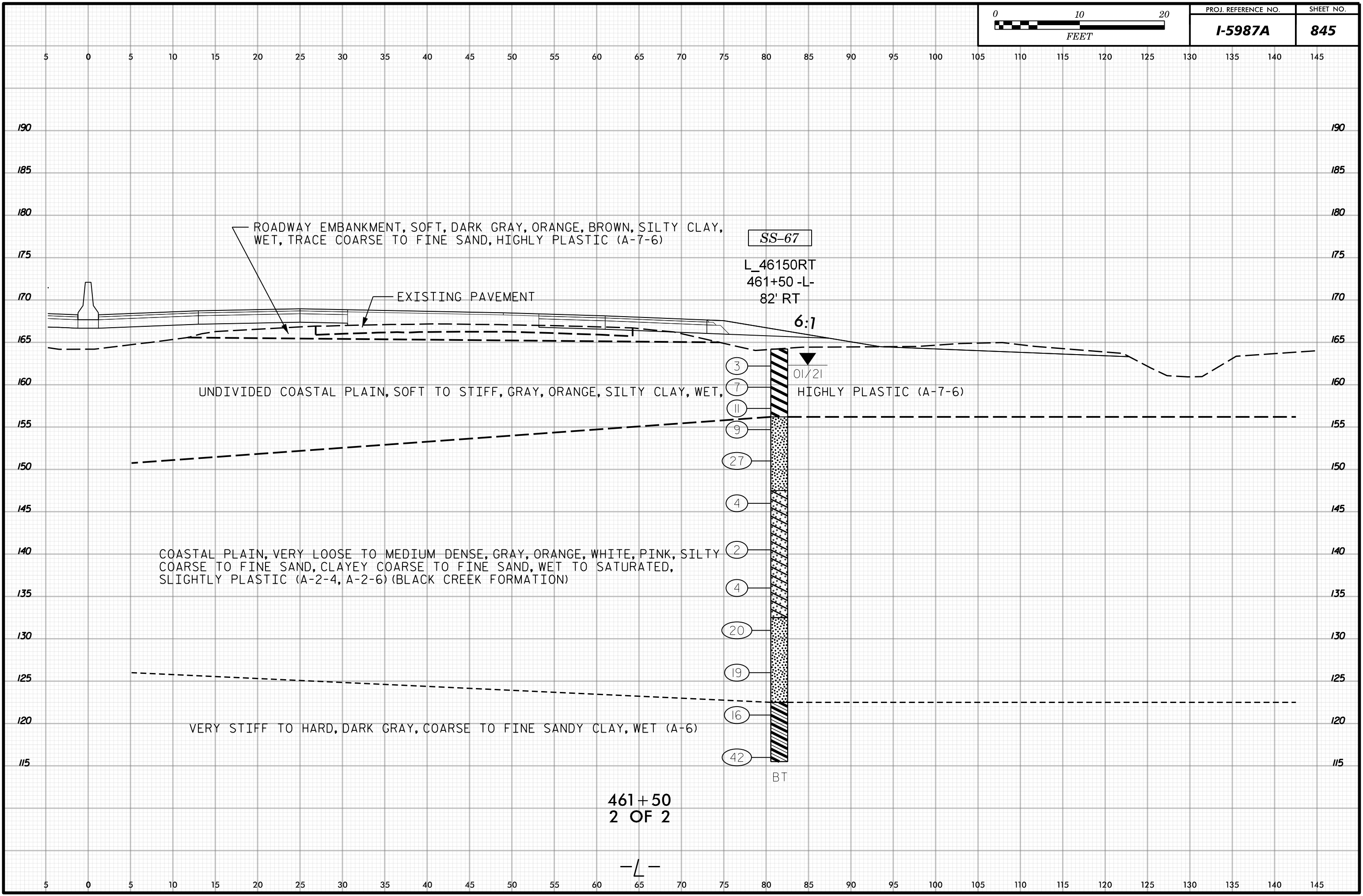

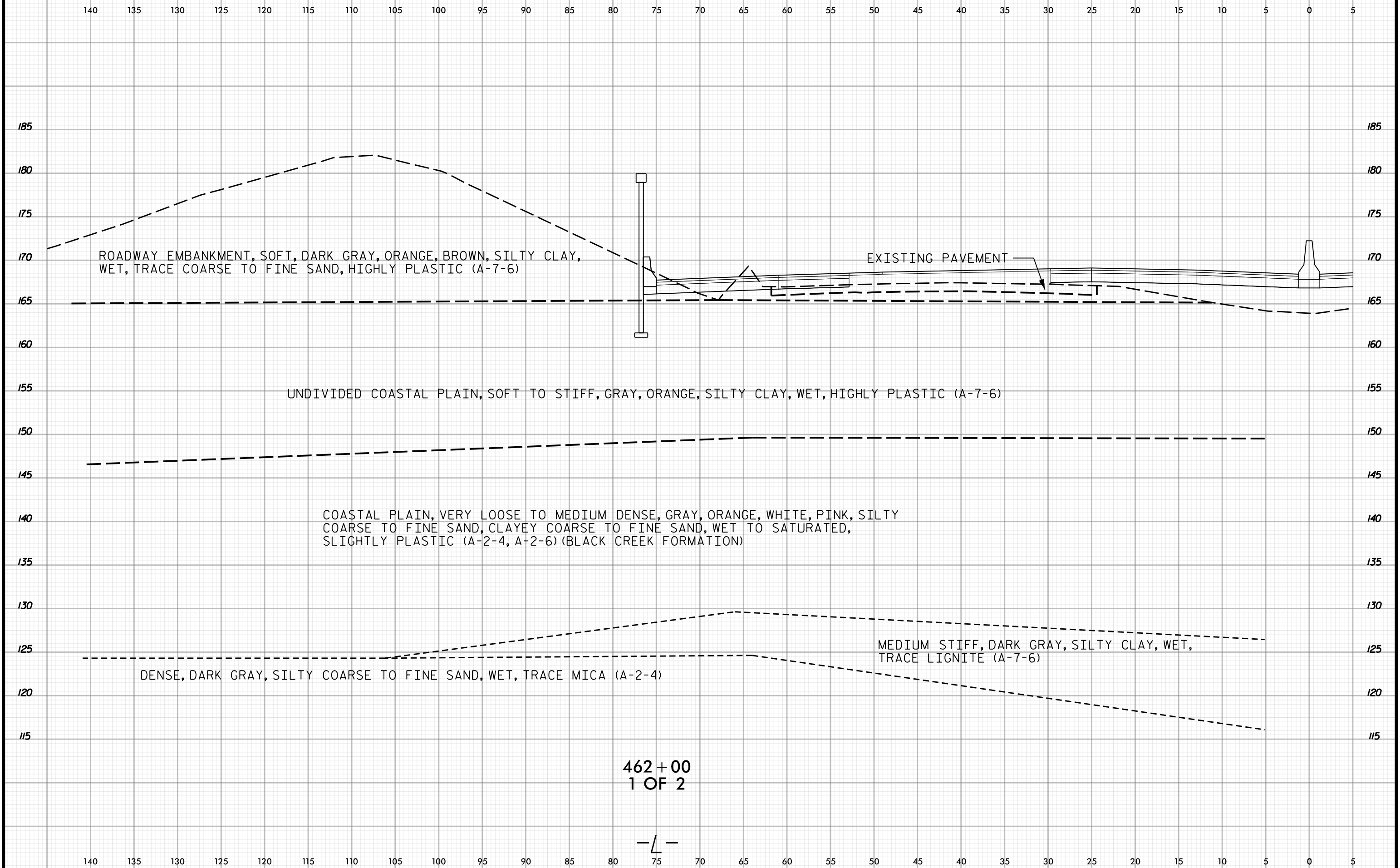

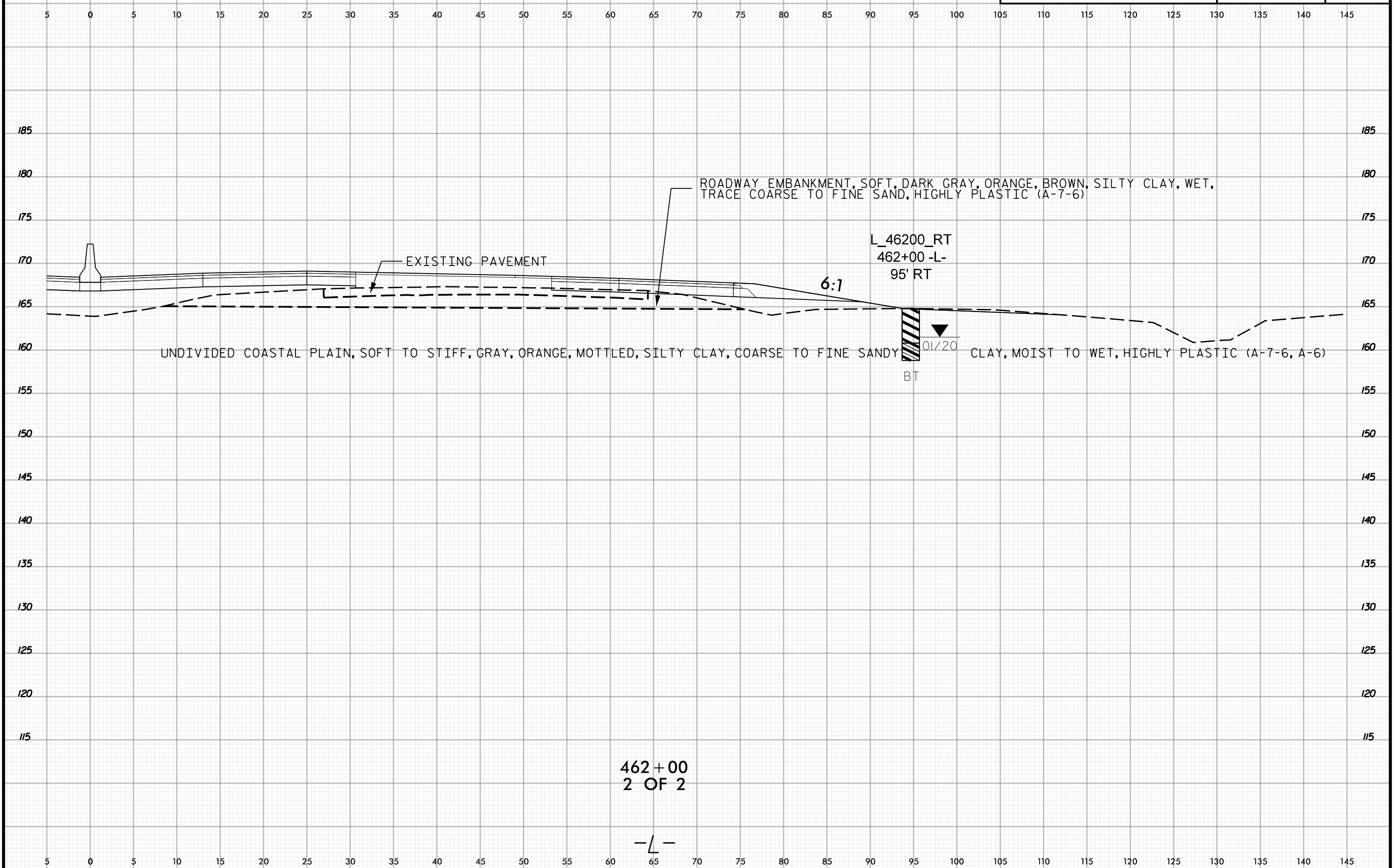

462+00
2 OF 2

—L—

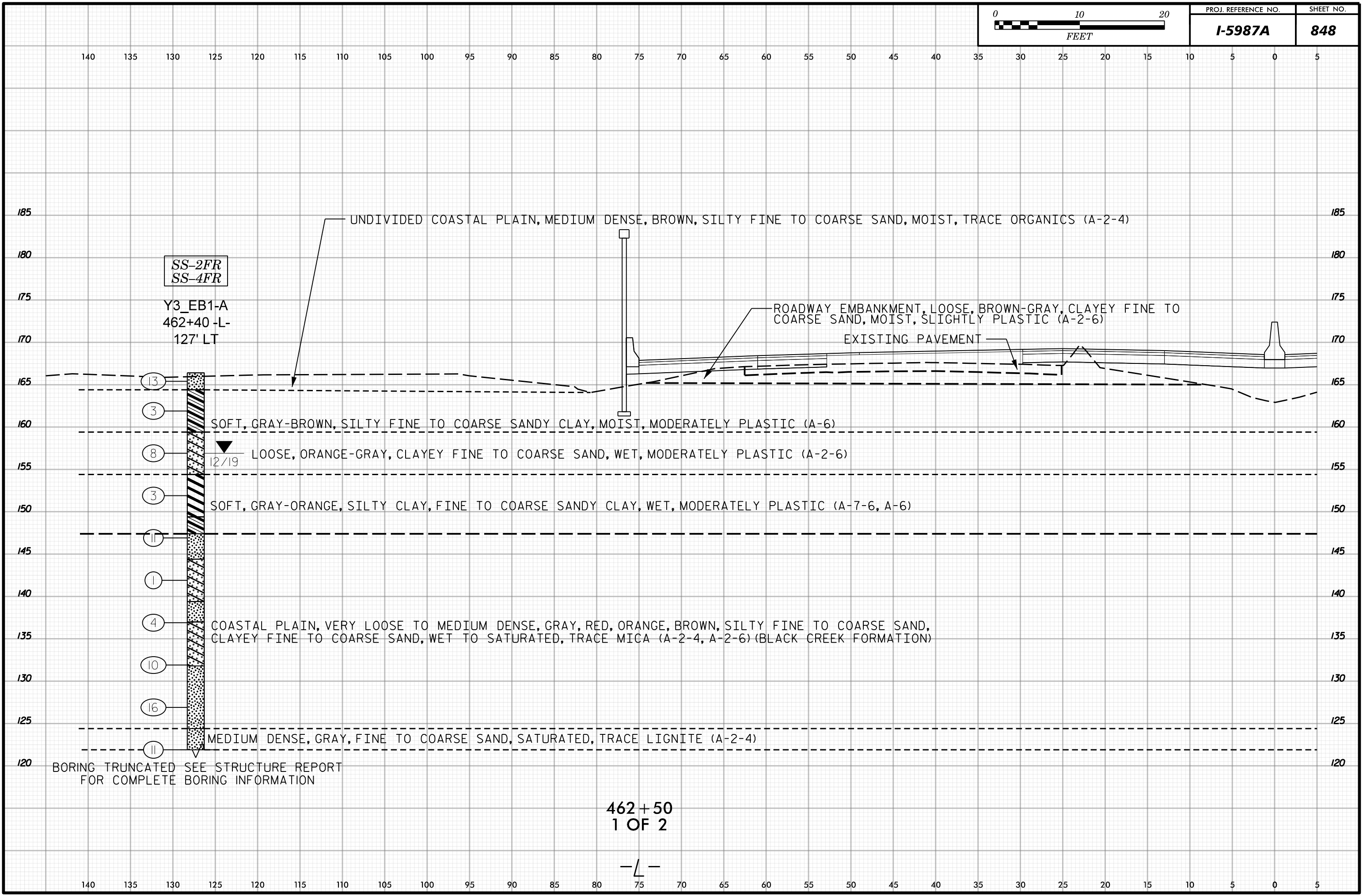

SS-2FR
SS-4FR

Y3_EB1-A
462+40 -L-
127' LT

- 13
- 3
- 8
- 3
- 11
- 1
- 4
- 10
- 16
- 11

UNDIVIDED COASTAL PLAIN, MEDIUM DENSE, BROWN, SILTY FINE TO COARSE SAND, MOIST, TRACE ORGANICS (A-2-4)

SOFT, GRAY-BROWN, SILTY FINE TO COARSE SANDY CLAY, MOIST, MODERATELY PLASTIC (A-6)

LOOSE, ORANGE-GRAY, CLAYEY FINE TO COARSE SAND, WET, MODERATELY PLASTIC (A-2-6)

SOFT, GRAY-ORANGE, SILTY CLAY, FINE TO COARSE SANDY CLAY, WET, MODERATELY PLASTIC (A-7-6, A-6)

COASTAL PLAIN, VERY LOOSE TO MEDIUM DENSE, GRAY, RED, ORANGE, BROWN, SILTY FINE TO COARSE SAND, CLAYEY FINE TO COARSE SAND, WET TO SATURATED, TRACE MICA (A-2-4, A-2-6) (BLACK CREEK FORMATION)

MEDIUM DENSE, GRAY, FINE TO COARSE SAND, SATURATED, TRACE LIGNITE (A-2-4)

ROADWAY EMBANKMENT, LOOSE, BROWN-GRAY, CLAYEY FINE TO COARSE SAND, MOIST, SLIGHTLY PLASTIC (A-2-6)

EXISTING PAVEMENT

BORING TRUNCATED SEE STRUCTURE REPORT FOR COMPLETE BORING INFORMATION

462 + 50
1 OF 2

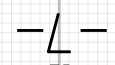

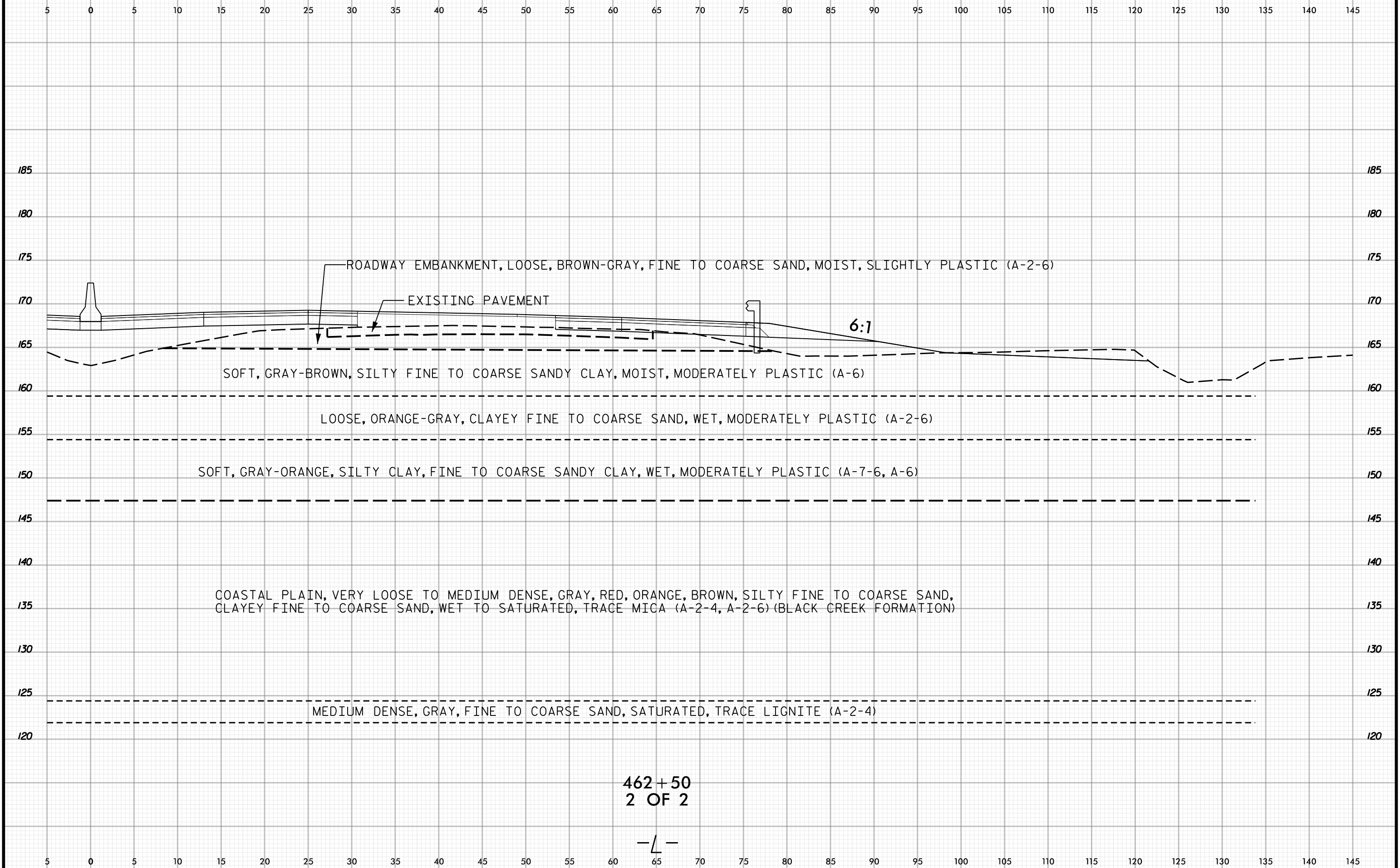

462 + 50
2 OF 2

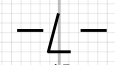

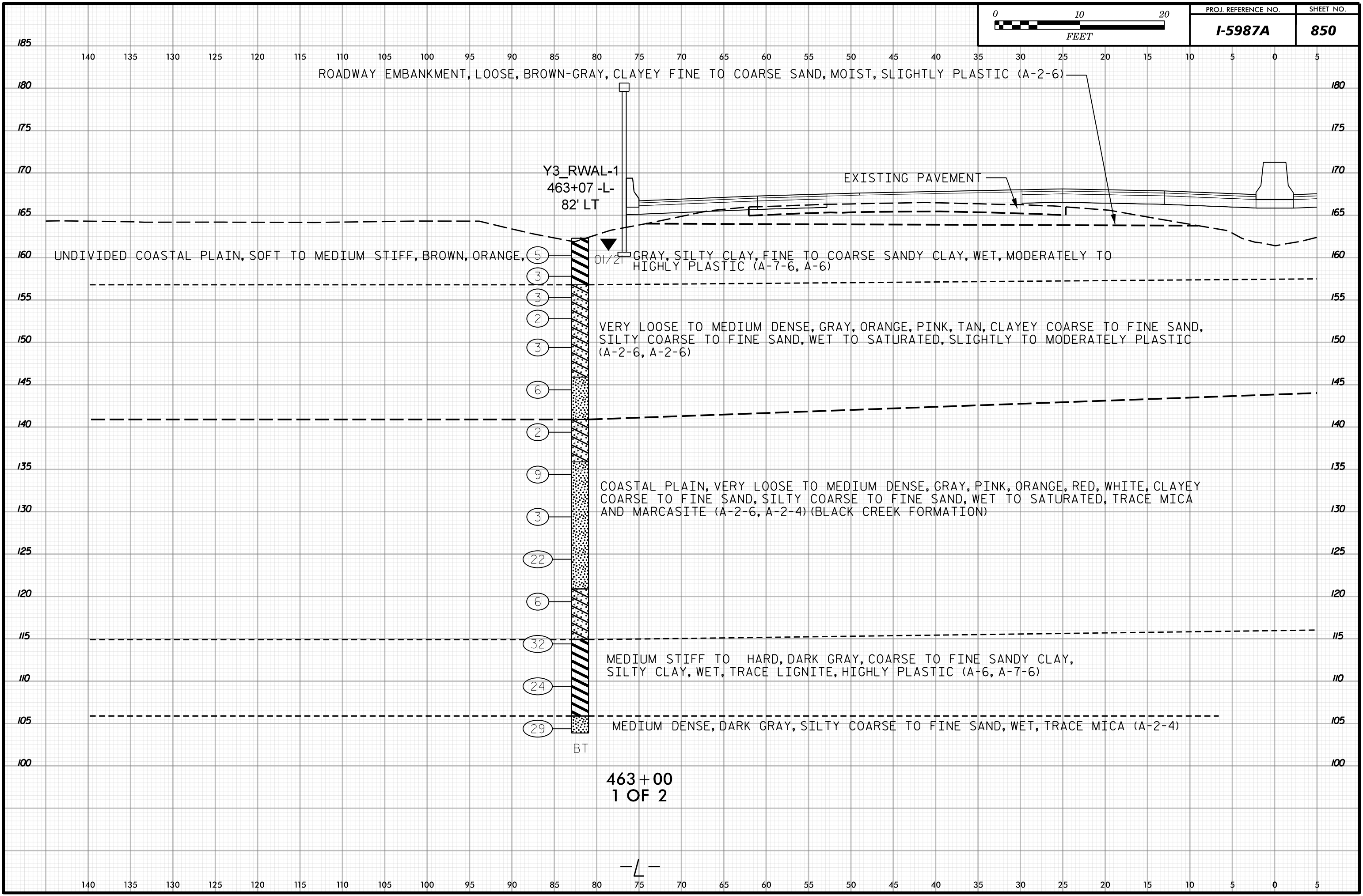
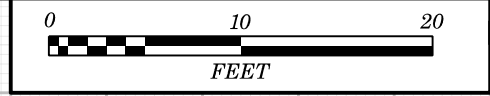

463+00
1 OF 2

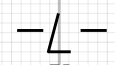

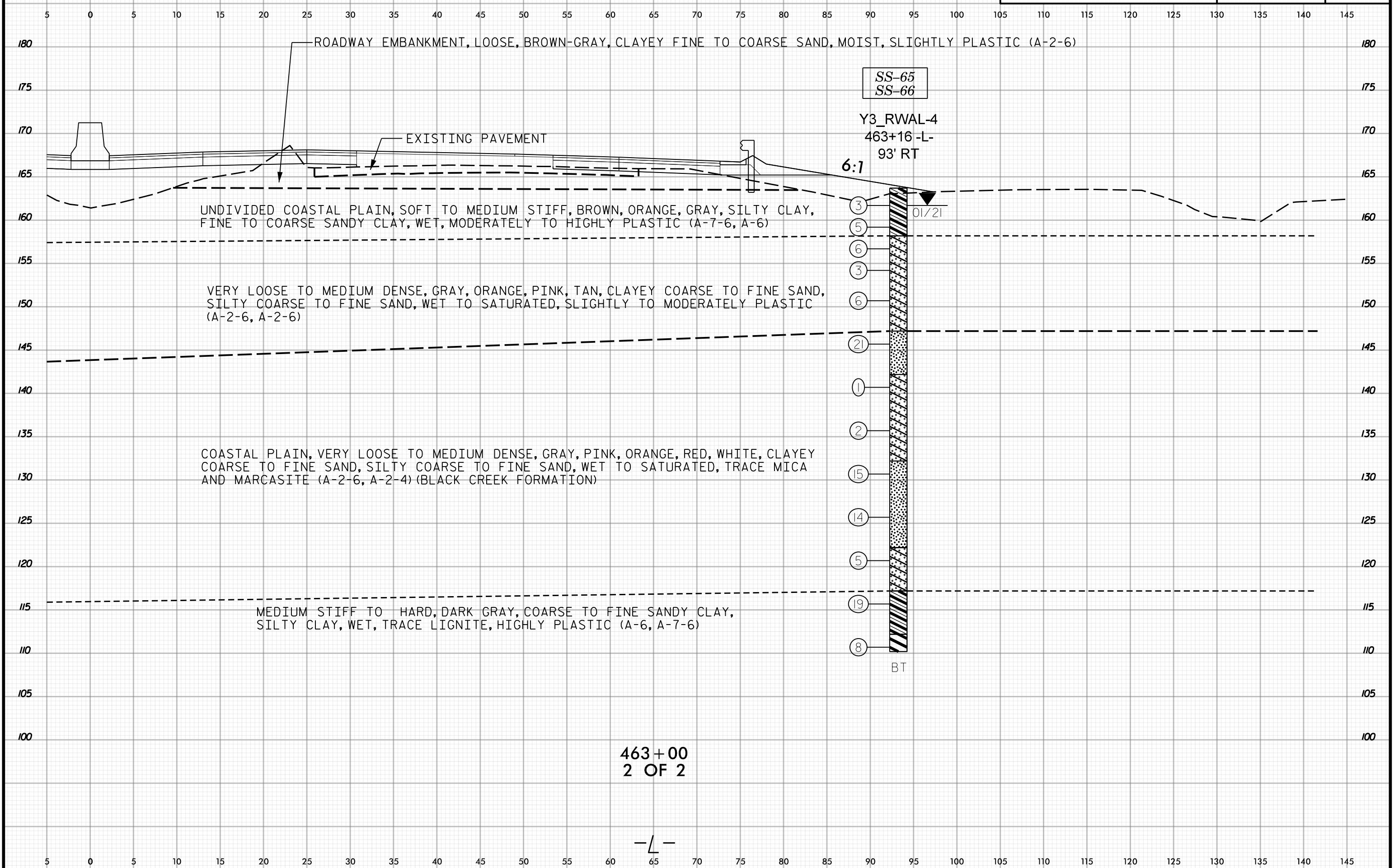
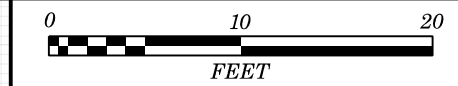

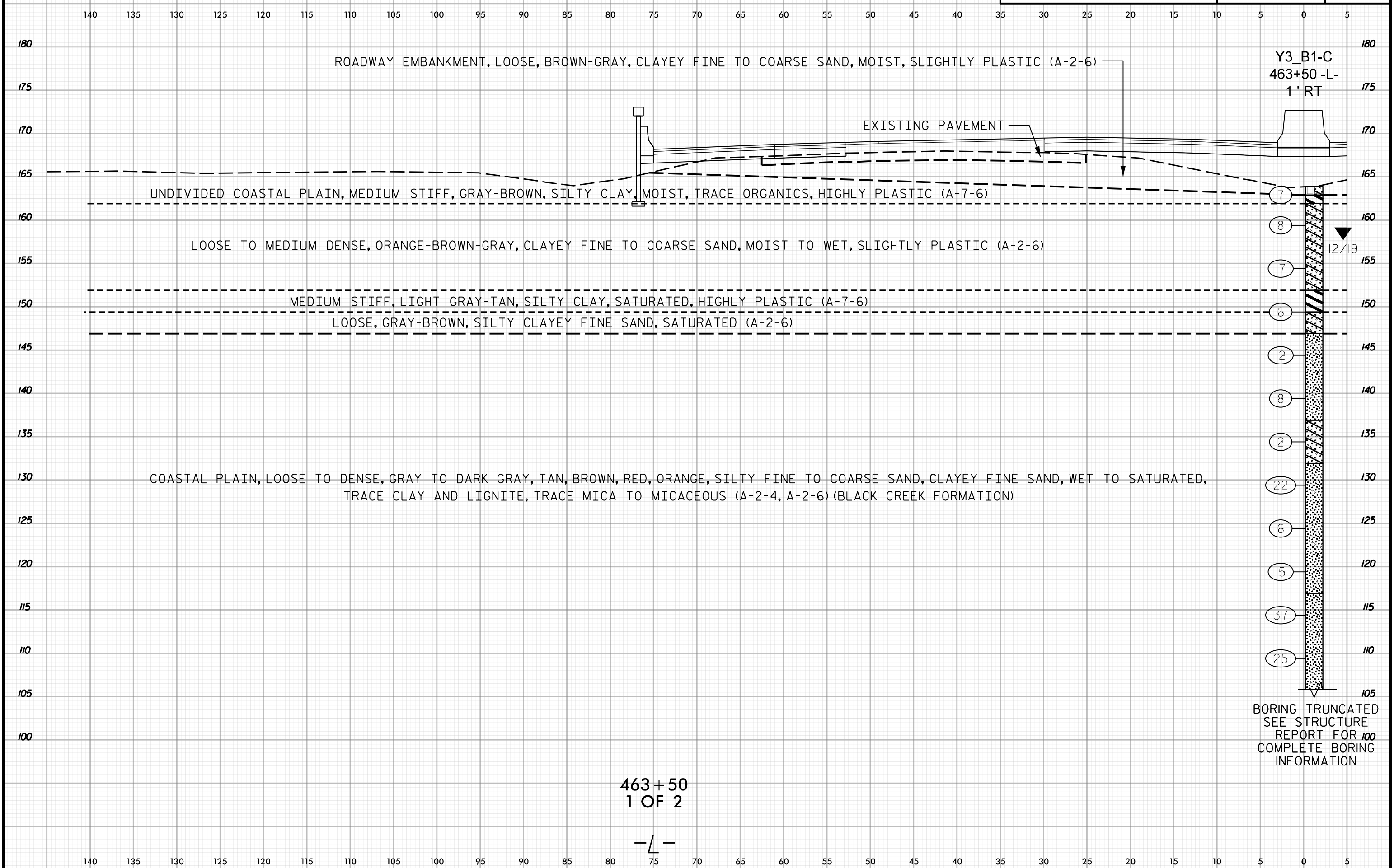
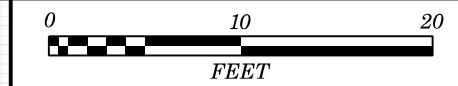

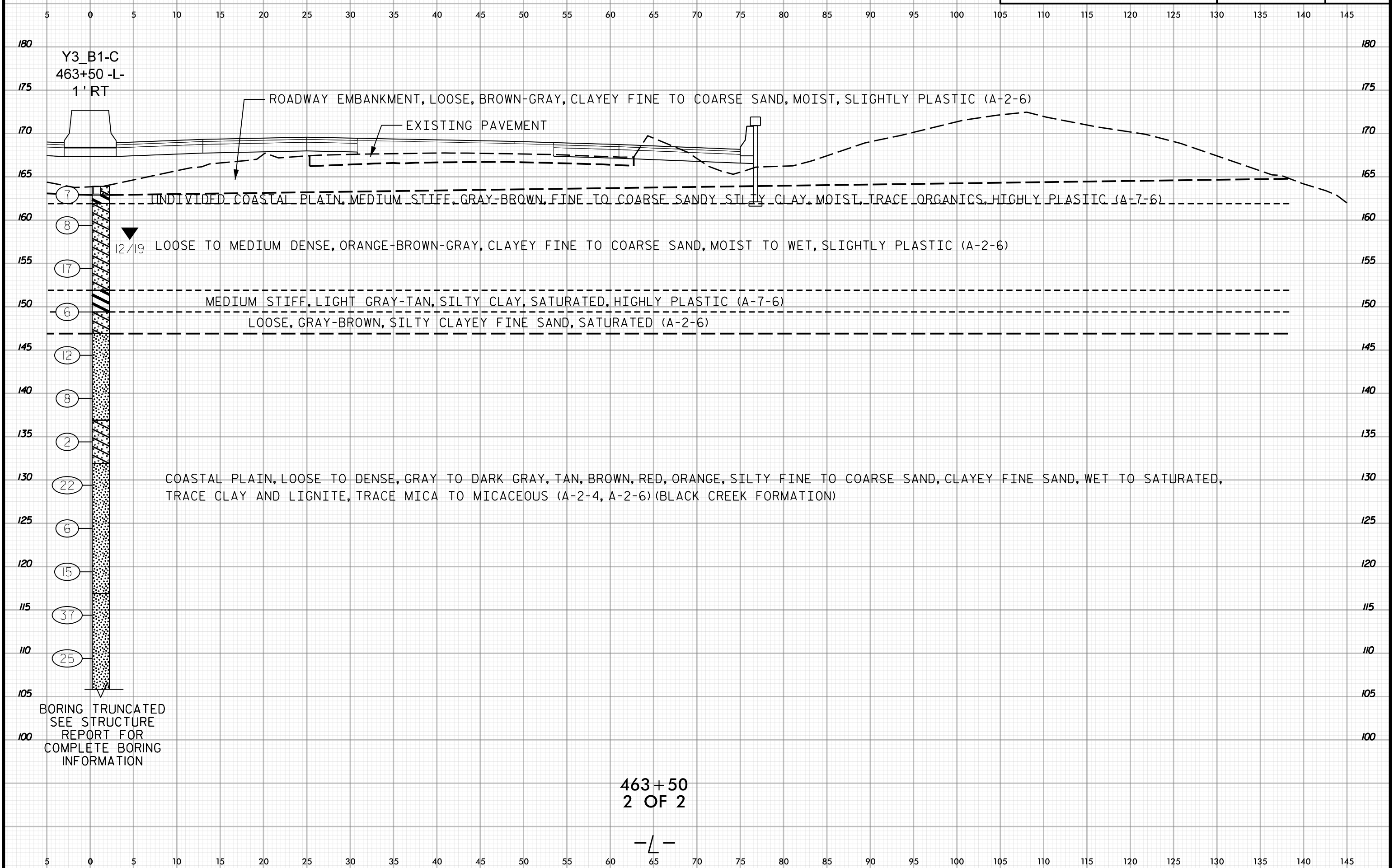
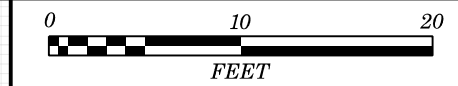

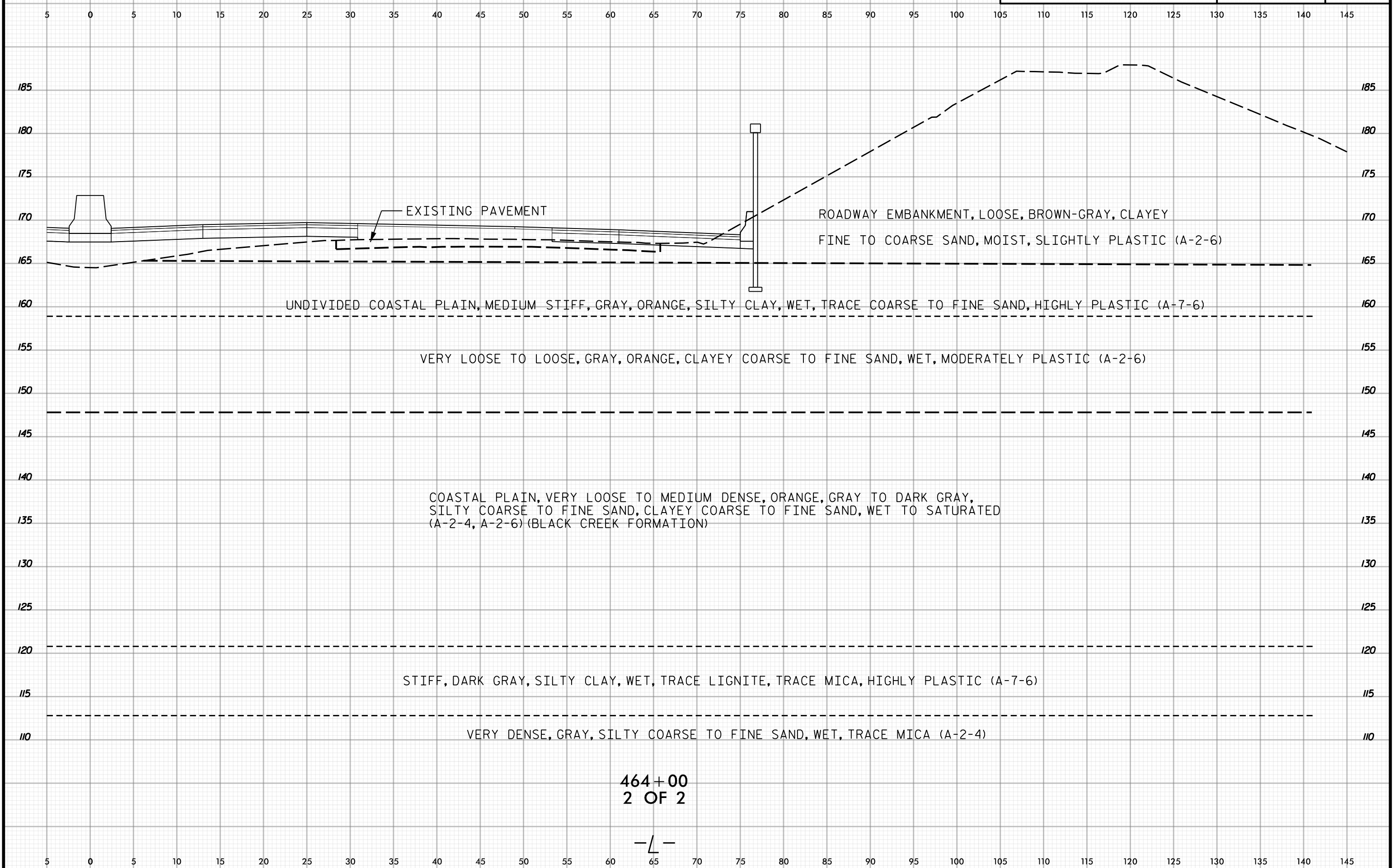

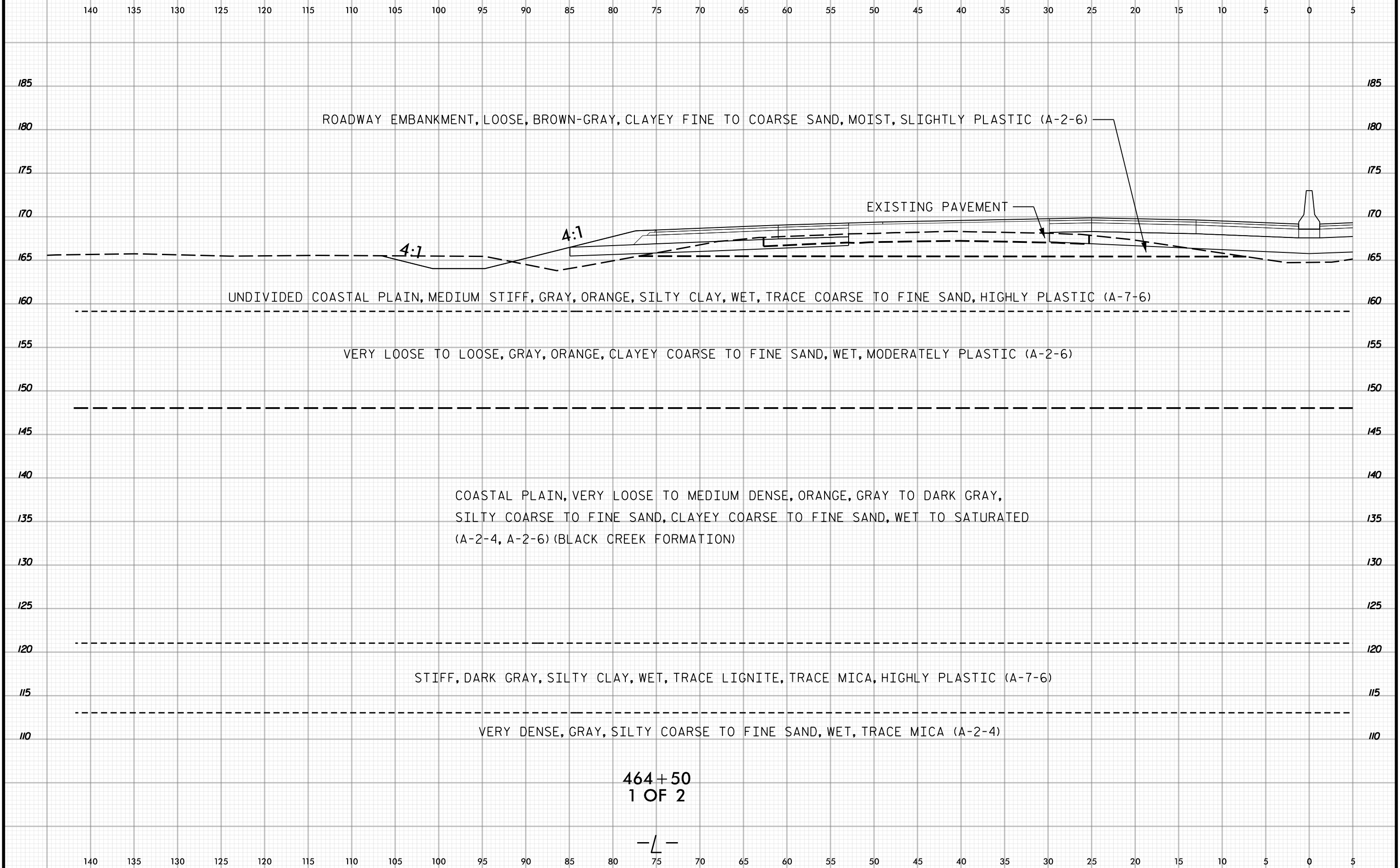

464+50
1 OF 2

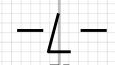

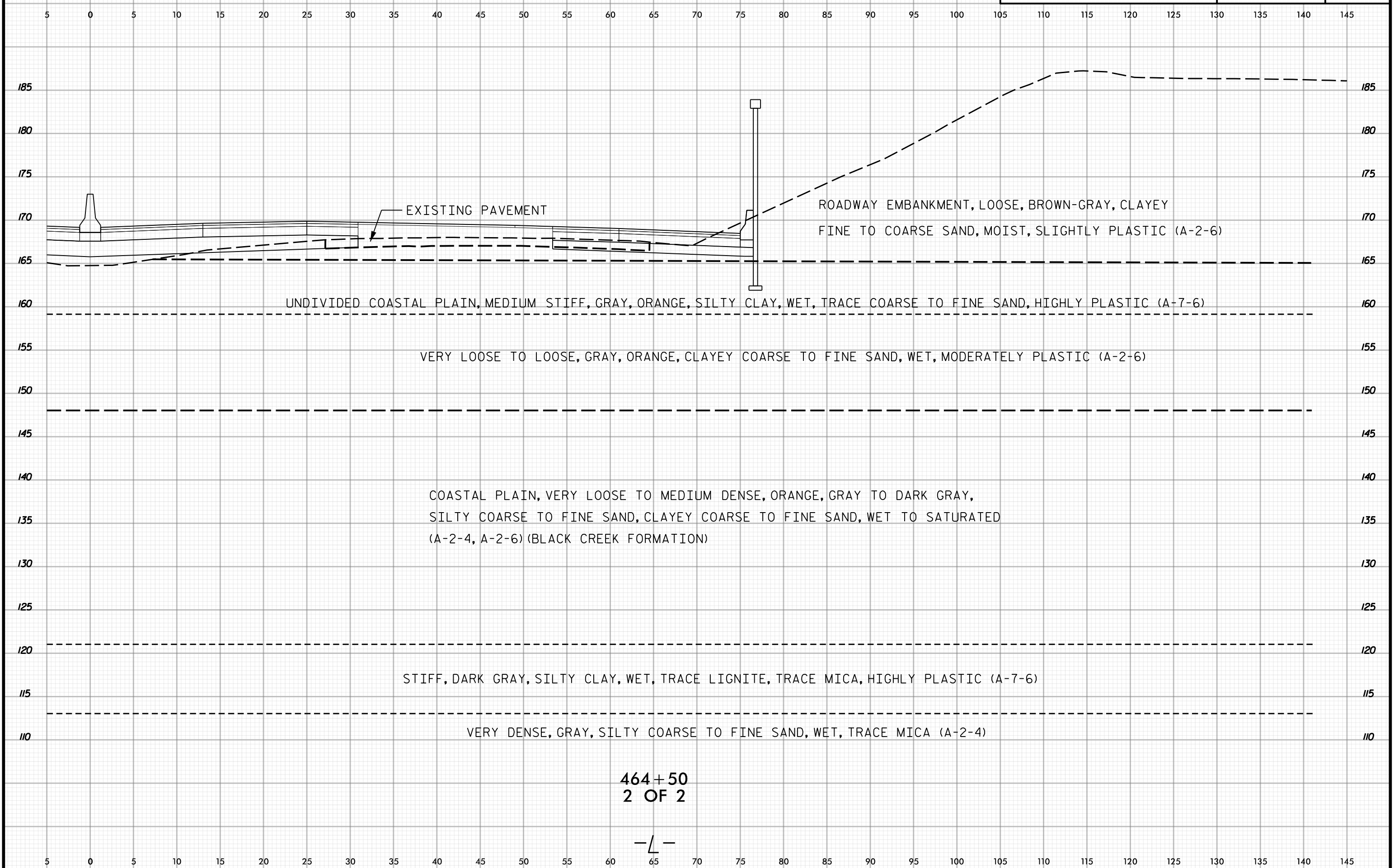

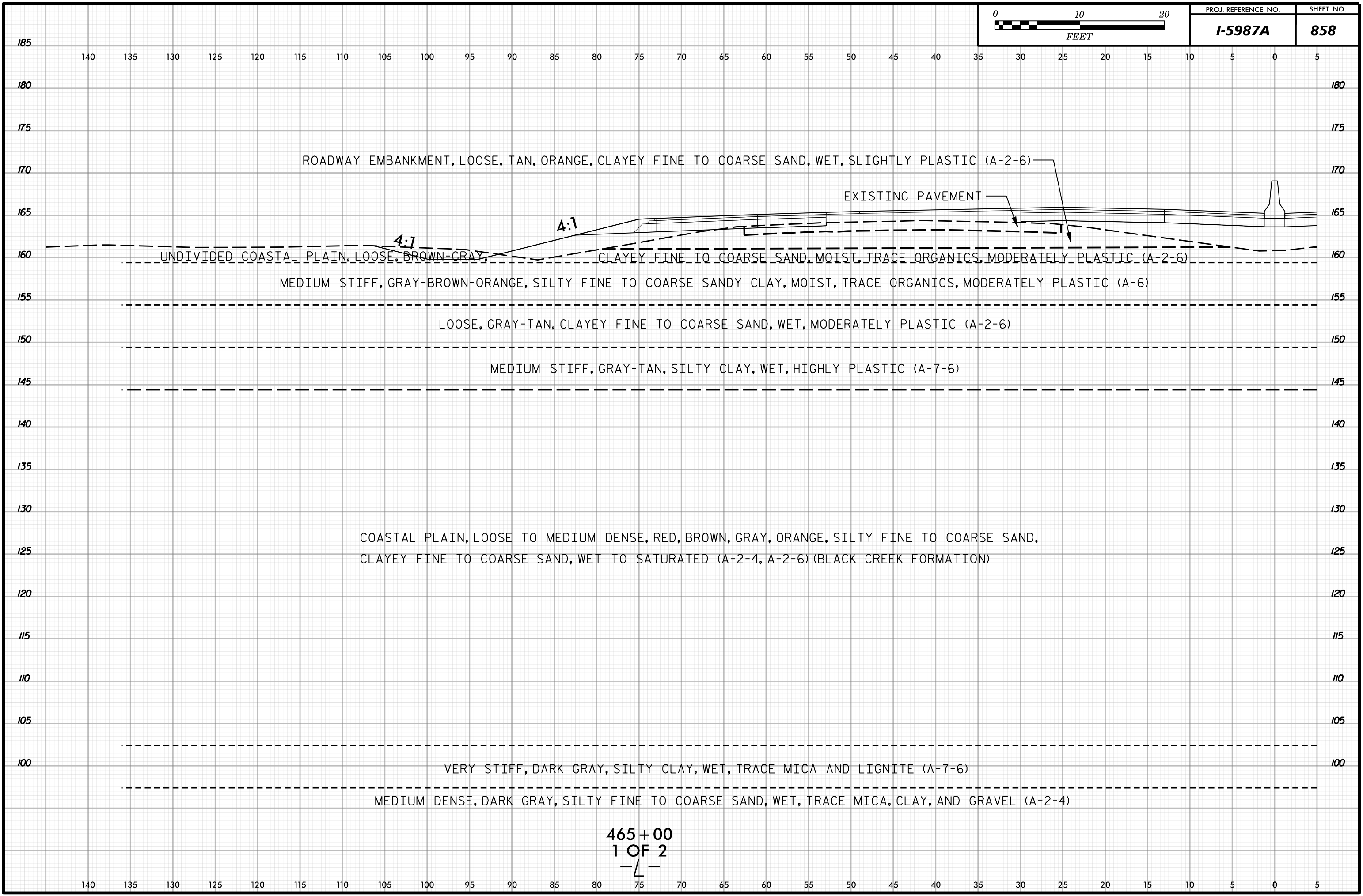

465 + 00
1 OF 2
—L—

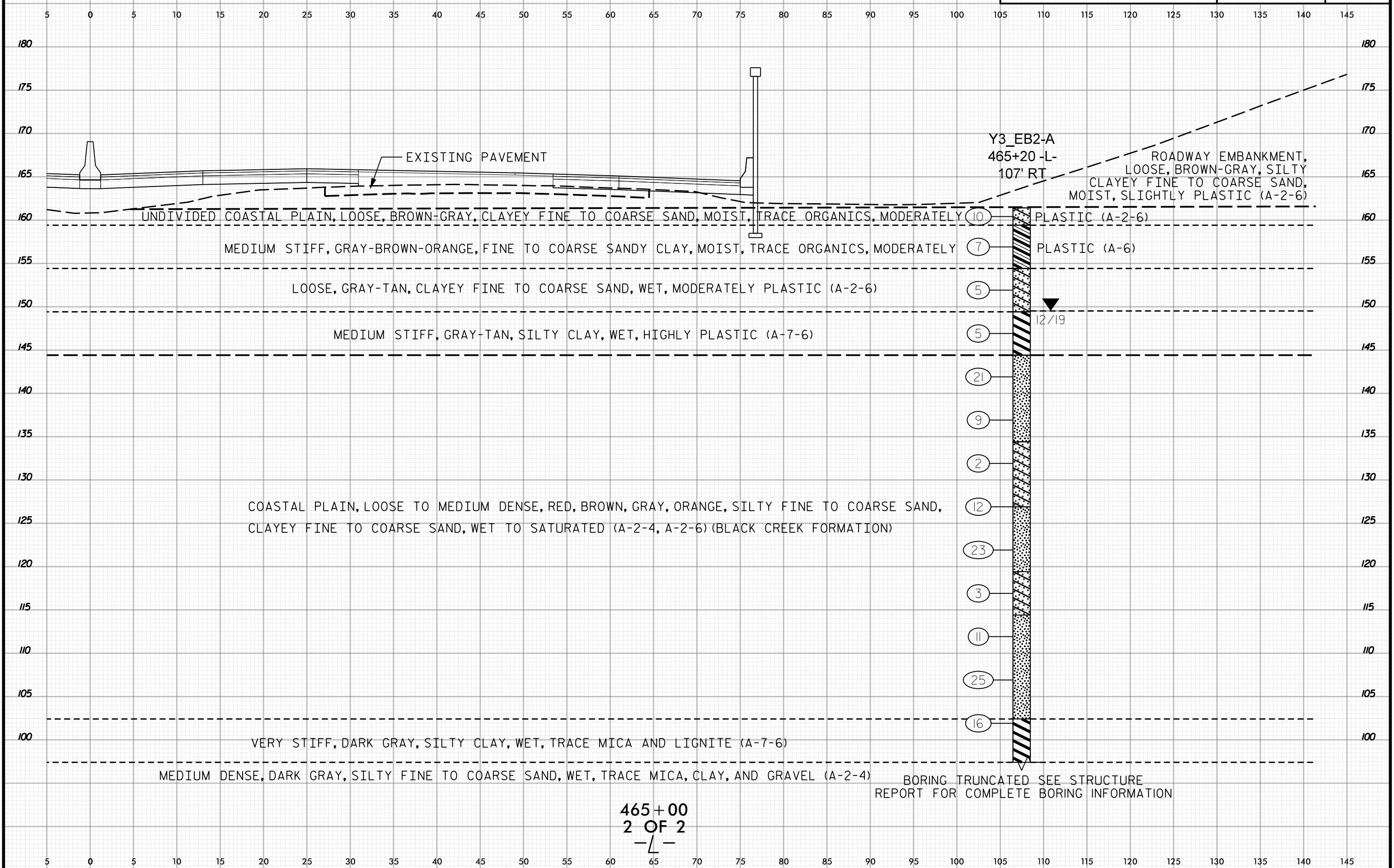
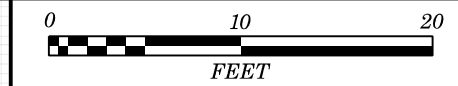

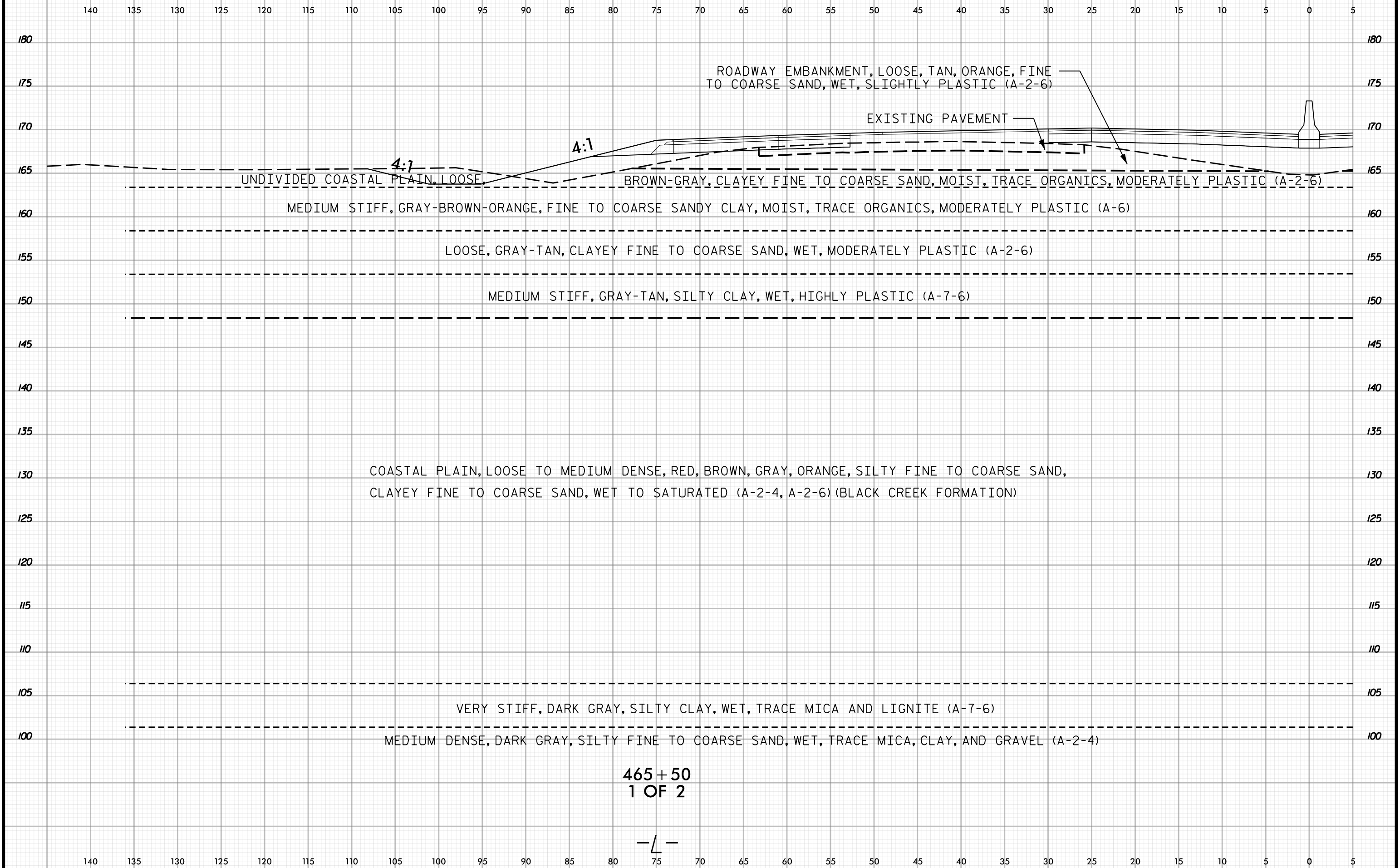

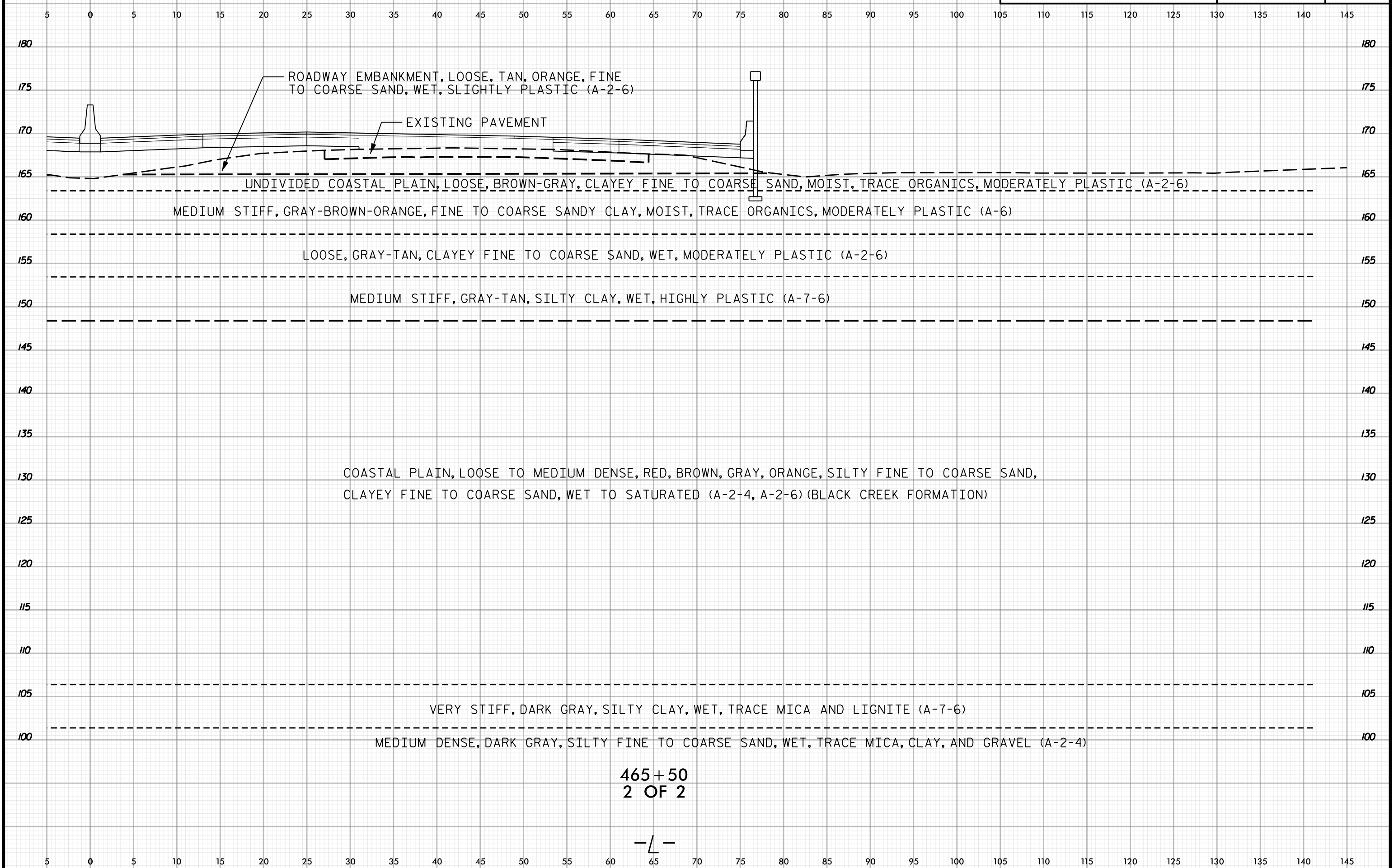

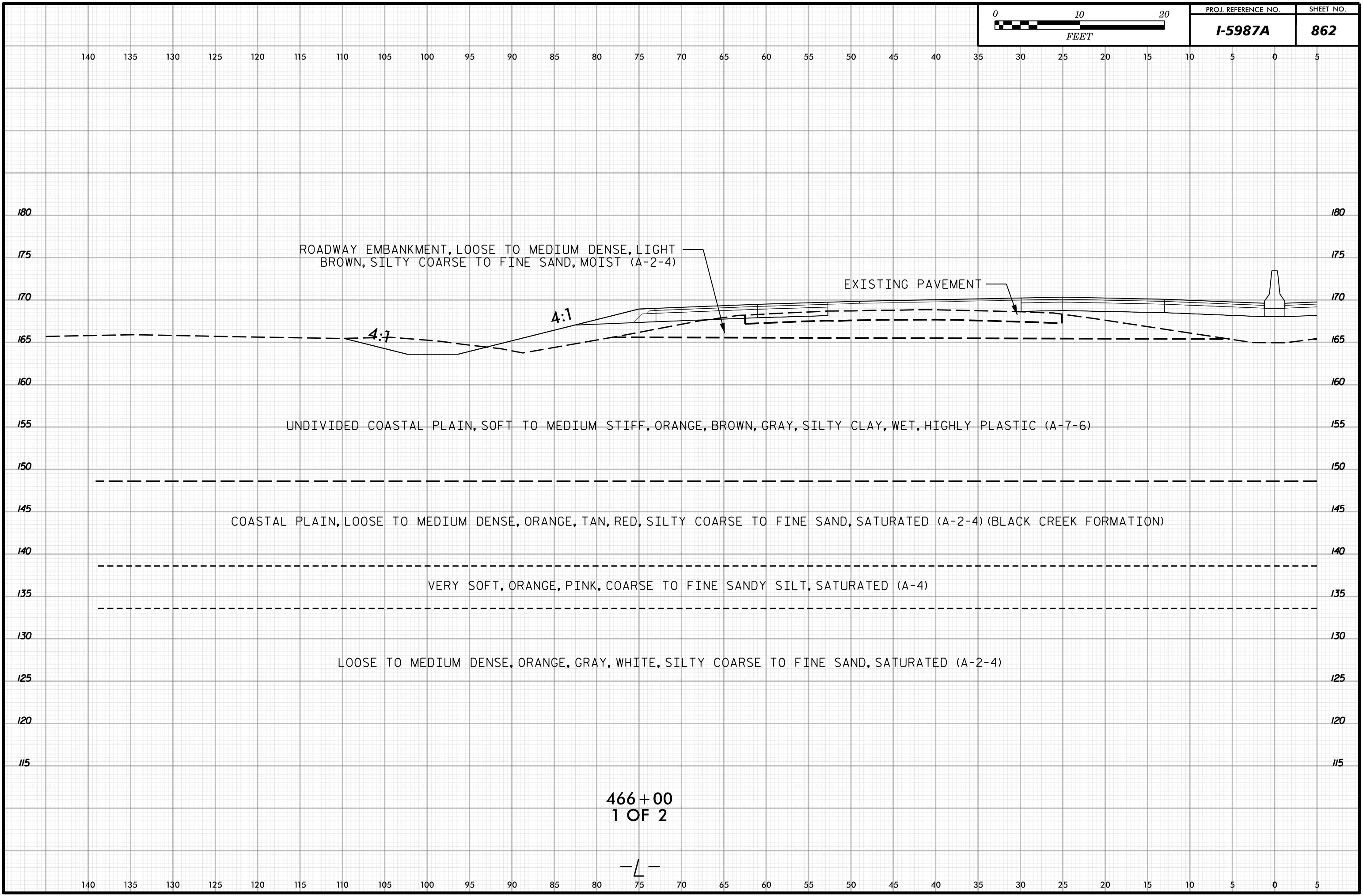

ROADWAY EMBANKMENT, LOOSE TO MEDIUM DENSE, LIGHT BROWN, SILTY COARSE TO FINE SAND, MOIST (A-2-4)

EXISTING PAVEMENT

UNDIVIDED COASTAL PLAIN, SOFT TO MEDIUM STIFF, ORANGE, BROWN, GRAY, SILTY CLAY, WET, HIGHLY PLASTIC (A-7-6)

COASTAL PLAIN, LOOSE TO MEDIUM DENSE, ORANGE, TAN, RED, SILTY COARSE TO FINE SAND, SATURATED (A-2-4) (BLACK CREEK FORMATION)

VERY SOFT, ORANGE, PINK, COARSE TO FINE SANDY SILT, SATURATED (A-4)

LOOSE TO MEDIUM DENSE, ORANGE, GRAY, WHITE, SILTY COARSE TO FINE SAND, SATURATED (A-2-4)

466+00
1 OF 2

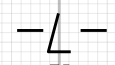

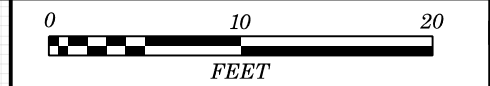

5 0 5 10 15 20 25 30 35 40 45 50 55 60 65 70 75 80 85 90 95 100 105 110 115 120 125 130 135 140 145

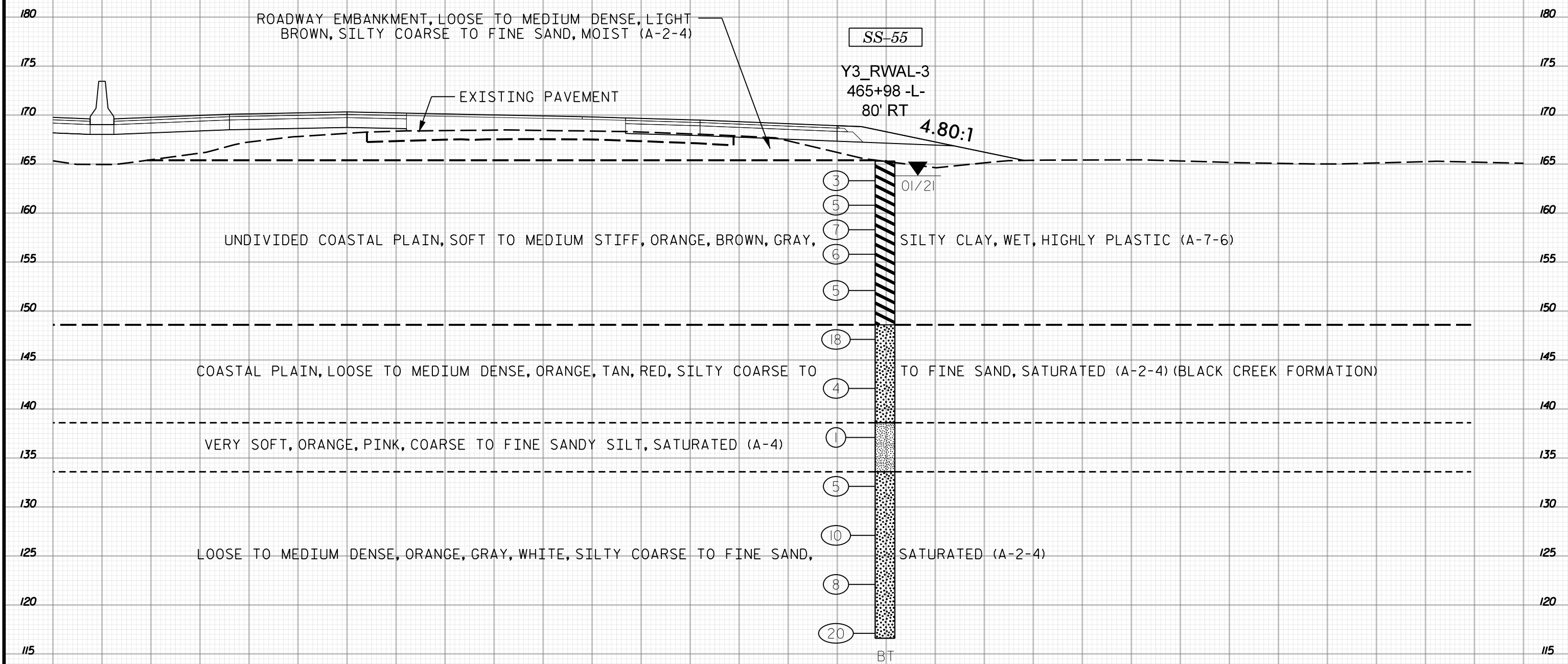

466+00
2 OF 2

-L-

5 0 5 10 15 20 25 30 35 40 45 50 55 60 65 70 75 80 85 90 95 100 105 110 115 120 125 130 135 140 145



PROJ. REFERENCE NO.	SHEET NO.
I-5987A	864

140 135 130 125 120 115 110 105 100 95 90 85 80 75 70 65 60 55 50 45 40 35 30 25 20 15 10 5 0 5

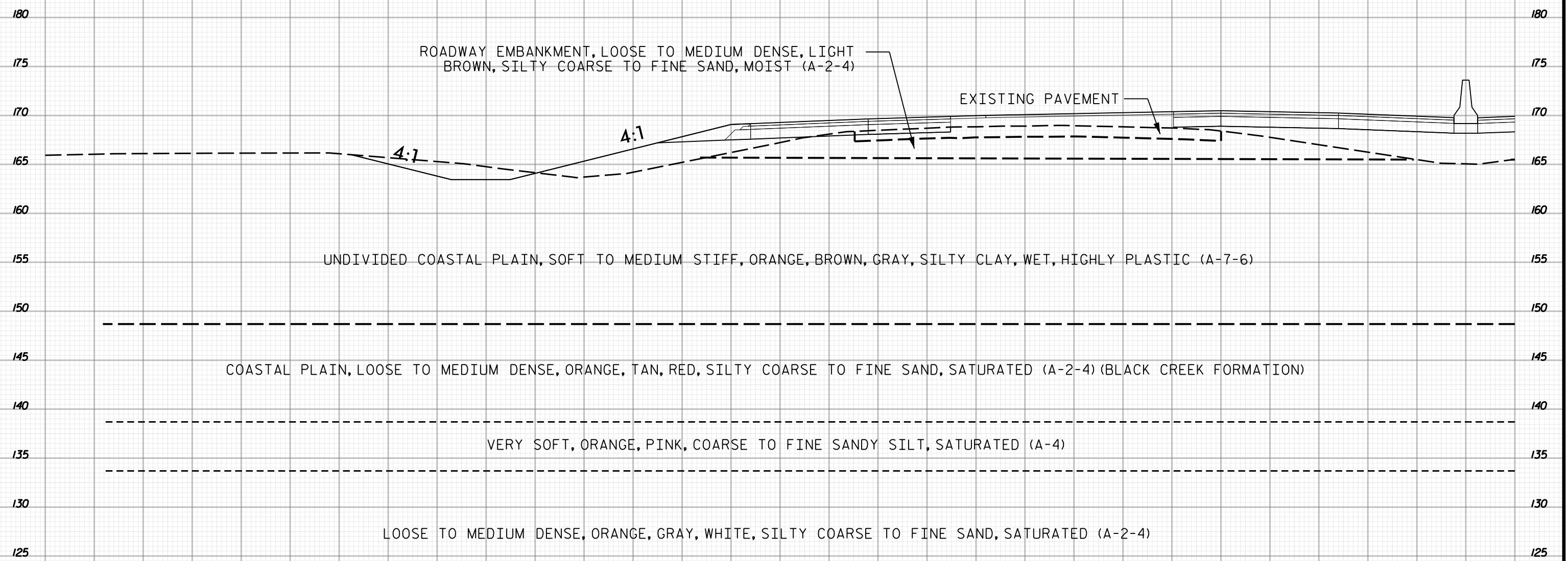

ROADWAY EMBANKMENT, LOOSE TO MEDIUM DENSE, LIGHT BROWN, SILTY COARSE TO FINE SAND, MOIST (A-2-4)

EXISTING PAVEMENT

UNDIVIDED COASTAL PLAIN, SOFT TO MEDIUM STIFF, ORANGE, BROWN, GRAY, SILTY CLAY, WET, HIGHLY PLASTIC (A-7-6)

COASTAL PLAIN, LOOSE TO MEDIUM DENSE, ORANGE, TAN, RED, SILTY COARSE TO FINE SAND, SATURATED (A-2-4) (BLACK CREEK FORMATION)

VERY SOFT, ORANGE, PINK, COARSE TO FINE SANDY SILT, SATURATED (A-4)

LOOSE TO MEDIUM DENSE, ORANGE, GRAY, WHITE, SILTY COARSE TO FINE SAND, SATURATED (A-2-4)

466 + 50
1 OF 2

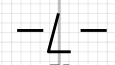

140 135 130 125 120 115 110 105 100 95 90 85 80 75 70 65 60 55 50 45 40 35 30 25 20 15 10 5 0 5



5 0 5 10 15 20 25 30 35 40 45 50 55 60 65 70 75 80 85 90 95 100 105 110 115 120 125 130 135 140 145

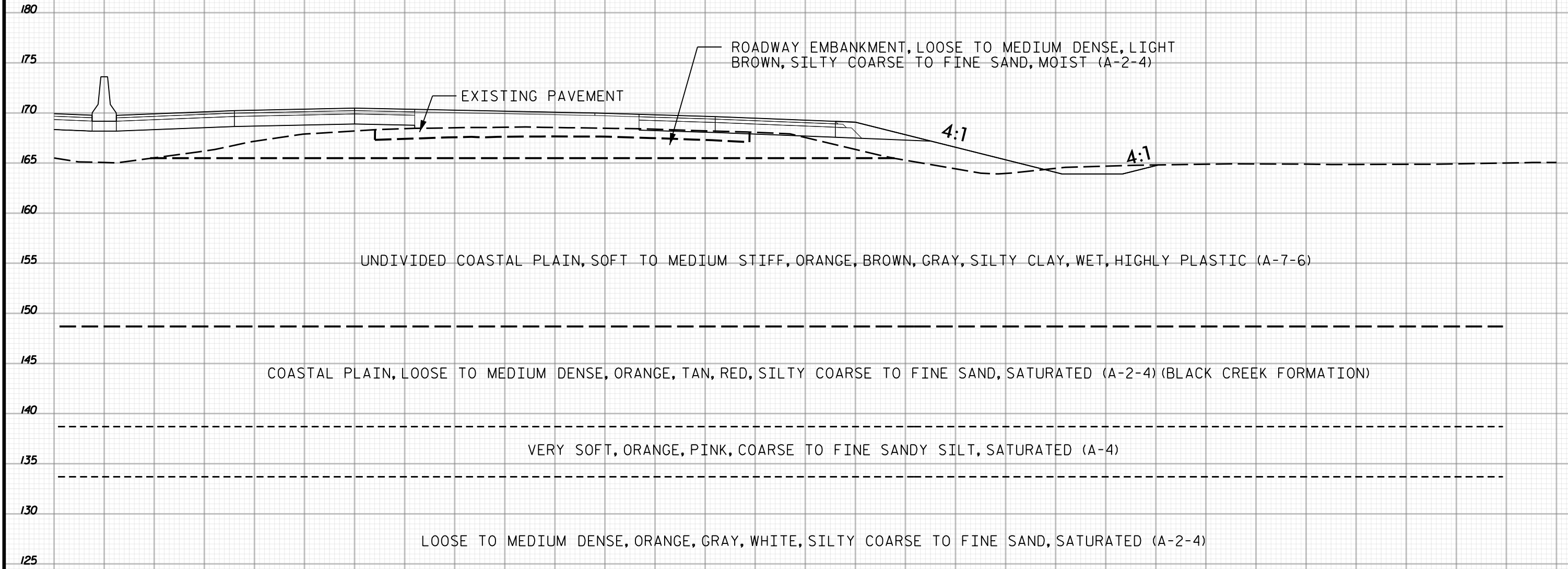

466+50
2 OF 2

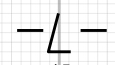

5 0 5 10 15 20 25 30 35 40 45 50 55 60 65 70 75 80 85 90 95 100 105 110 115 120 125 130 135 140 145



140 135 130 125 120 115 110 105 100 95 90 85 80 75 70 65 60 55 50 45 40 35 30 25 20 15 10 5 0 5

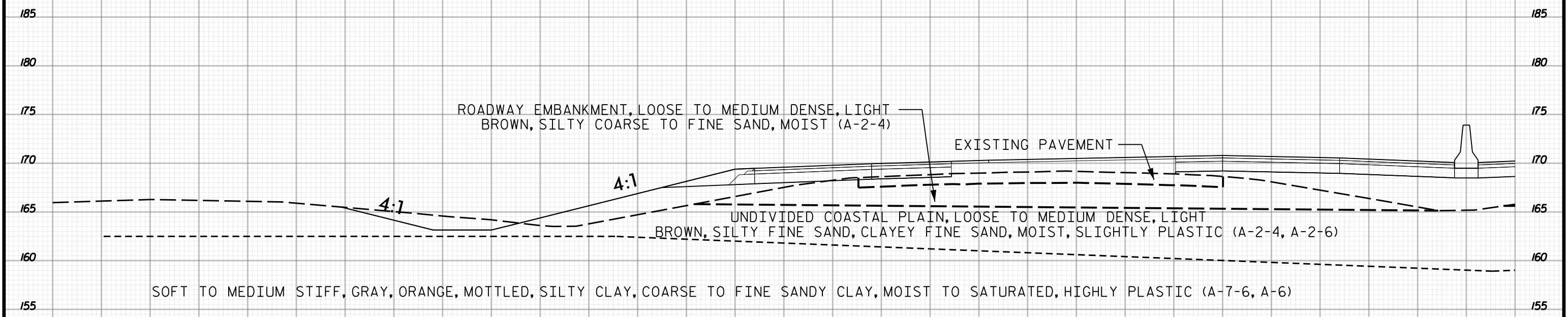

467+50

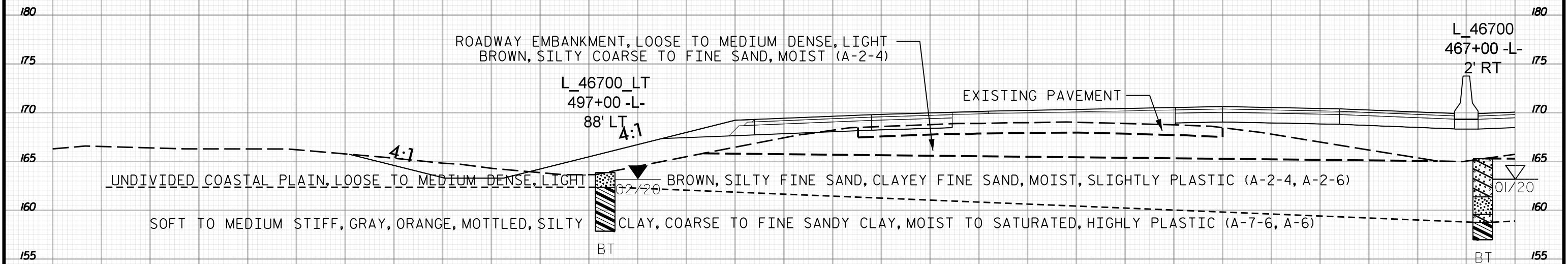

467+00
1 OF 2

140 135 130 125 120 115 110 105 100 95 90 85 80 75 70 65 60 55 50 45 40 35 30 25 20 15 10 5 0 5



5 0 5 10 15 20 25 30 35 40 45 50 55 60 65 70 75 80 85 90 95 100 105 110 115 120 125 130 135 140 145

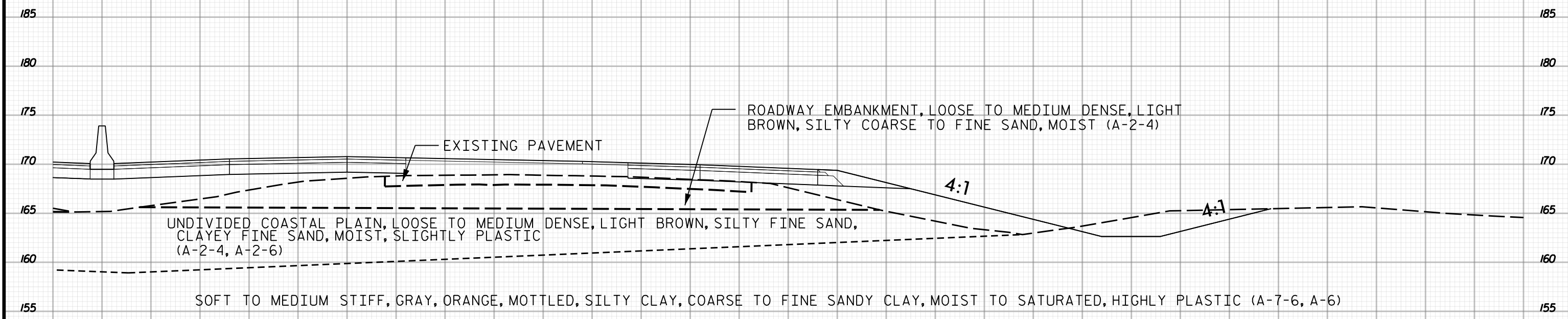

467+50

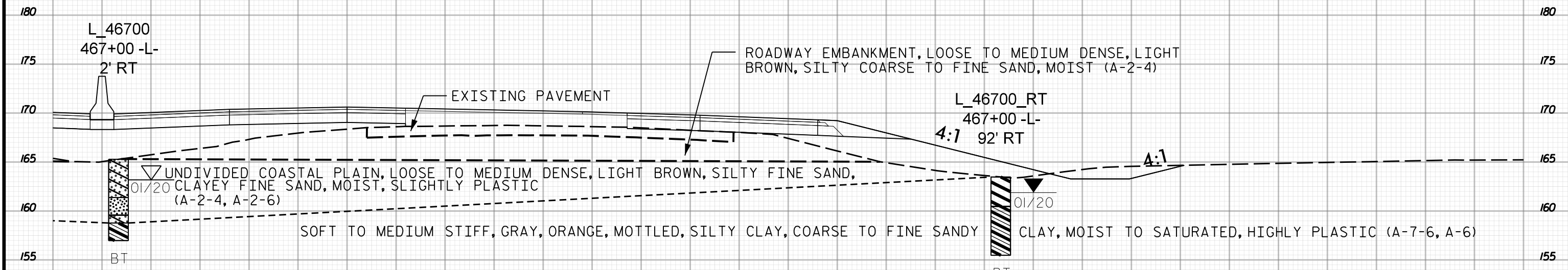

467+00
2 OF 2

-L-

5 0 5 10 15 20 25 30 35 40 45 50 55 60 65 70 75 80 85 90 95 100 105 110 115 120 125 130 135 140 145



140 135 130 125 120 115 110 105 100 95 90 85 80 75 70 65 60 55 50 45 40 35 30 25 20 15 10 5 0 5

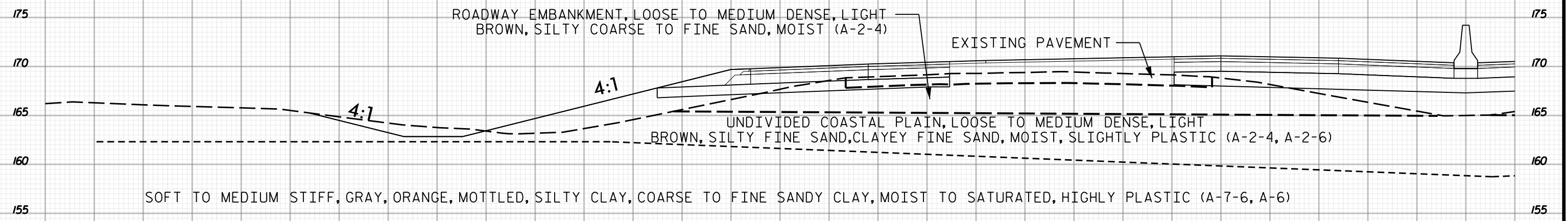

468+50

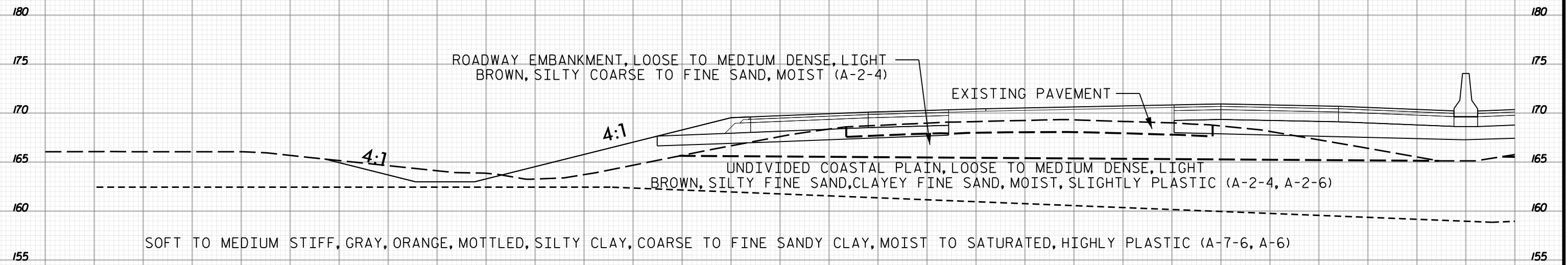

468+00
1 OF 2

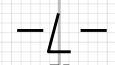

140 135 130 125 120 115 110 105 100 95 90 85 80 75 70 65 60 55 50 45 40 35 30 25 20 15 10 5 0 5



5 0 5 10 15 20 25 30 35 40 45 50 55 60 65 70 75 80 85 90 95 100 105 110 115 120 125 130 135 140 145

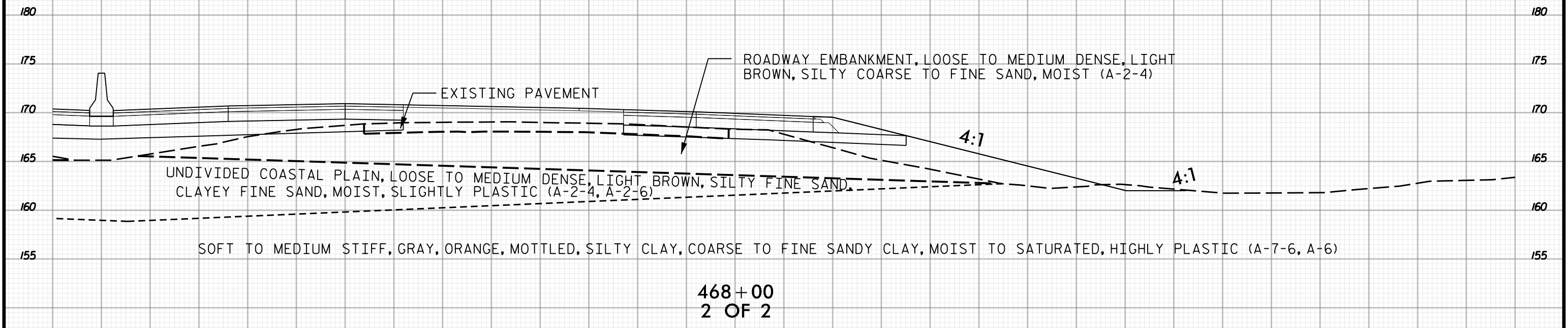
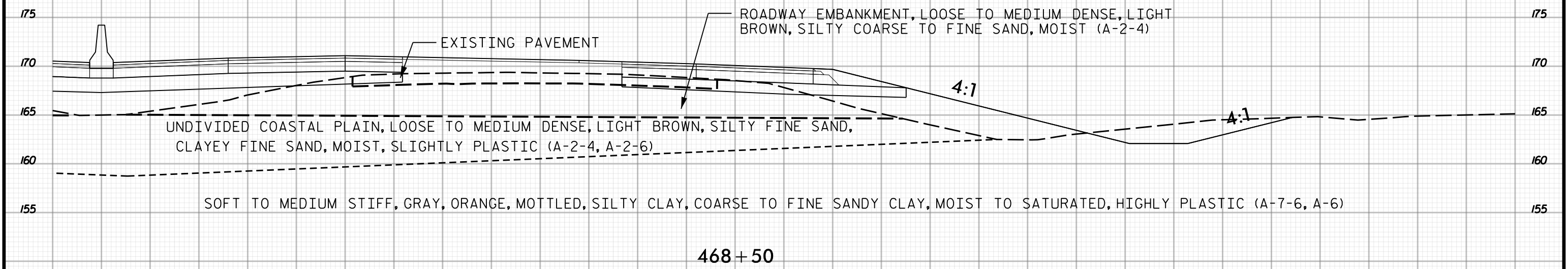

5 0 5 10 15 20 25 30 35 40 45 50 55 60 65 70 75 80 85 90 95 100 105 110 115 120 125 130 135 140 145

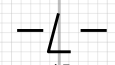



140 135 130 125 120 115 110 105 100 95 90 85 80 75 70 65 60 55 50 45 40 35 30 25 20 15 10 5 0 5

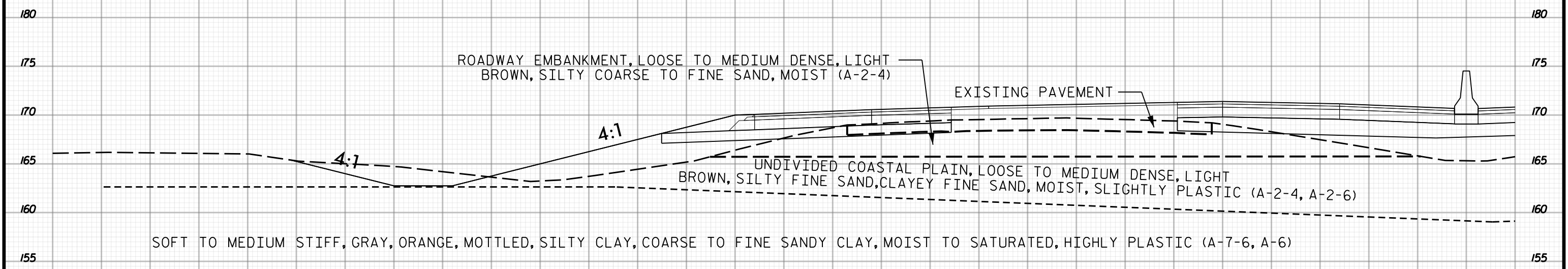

469+50

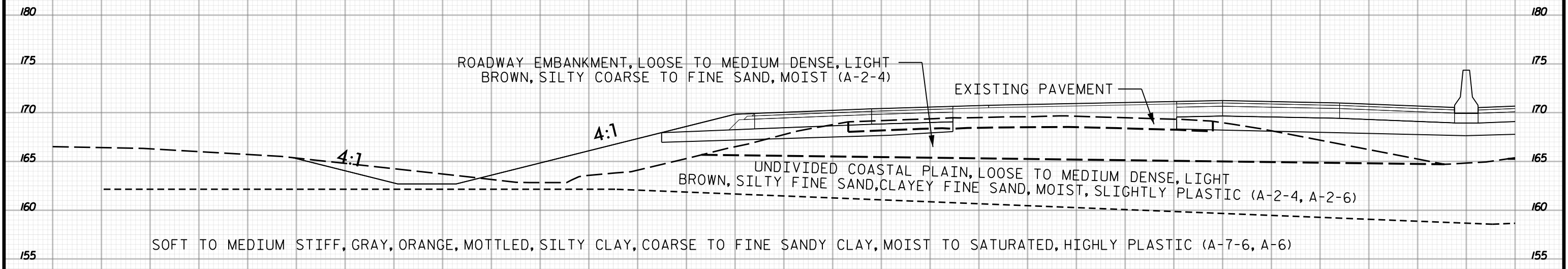

469+00
1 OF 2

140 135 130 125 120 115 110 105 100 95 90 85 80 75 70 65 60 55 50 45 40 35 30 25 20 15 10 5 0 5

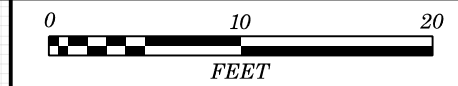

5 0 5 10 15 20 25 30 35 40 45 50 55 60 65 70 75 80 85 90 95 100 105 110 115 120 125 130 135 140 145

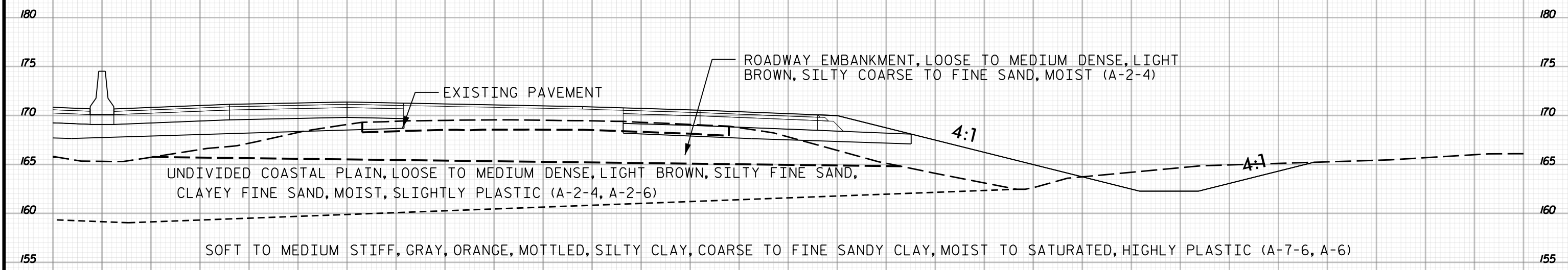

469 + 50

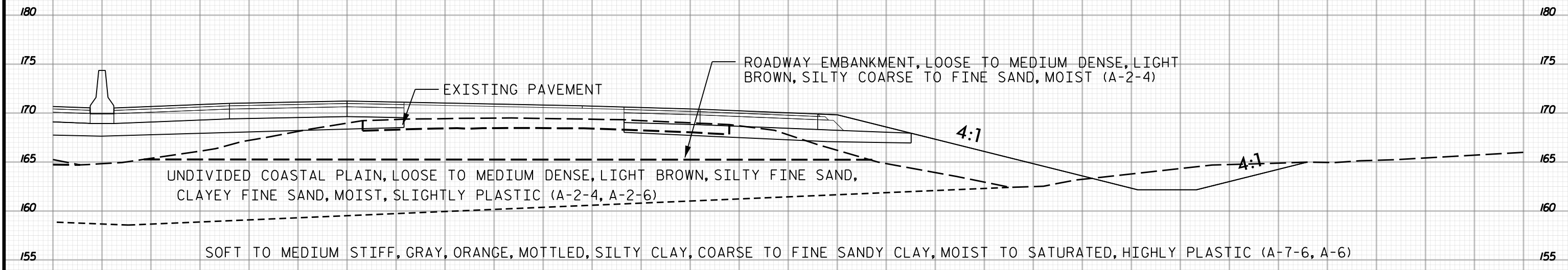

469 + 00
2 OF 2

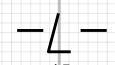

5 0 5 10 15 20 25 30 35 40 45 50 55 60 65 70 75 80 85 90 95 100 105 110 115 120 125 130 135 140 145



140 135 130 125 120 115 110 105 100 95 90 85 80 75 70 65 60 55 50 45 40 35 30 25 20 15 10 5 0 5

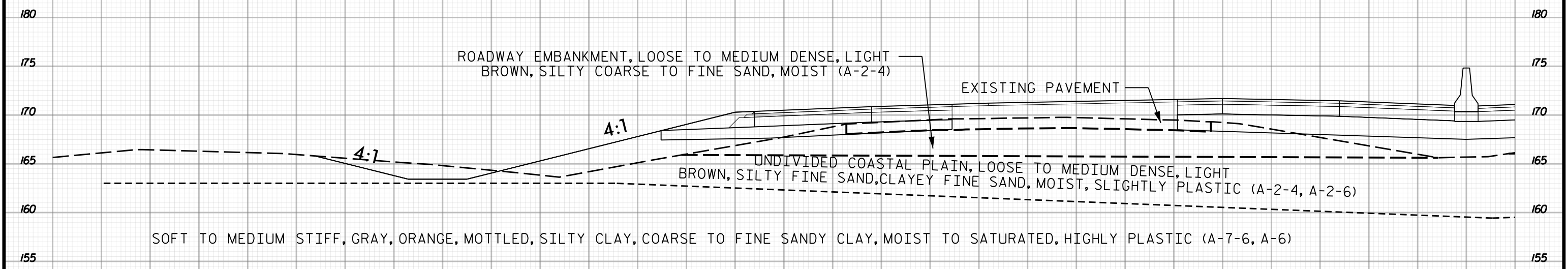

470+50

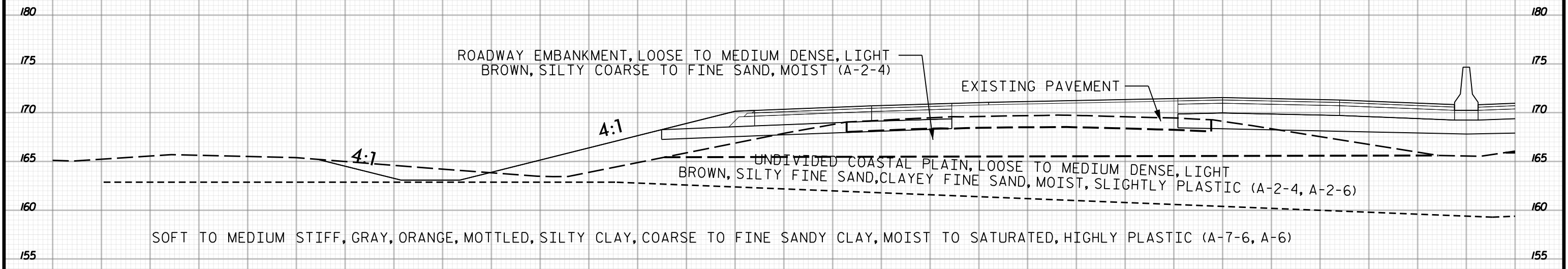

470+00
1 OF 2

140 135 130 125 120 115 110 105 100 95 90 85 80 75 70 65 60 55 50 45 40 35 30 25 20 15 10 5 0 5

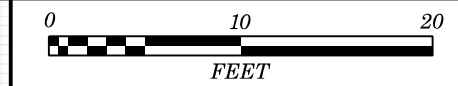

5 0 5 10 15 20 25 30 35 40 45 50 55 60 65 70 75 80 85 90 95 100 105 110 115 120 125 130 135 140 145

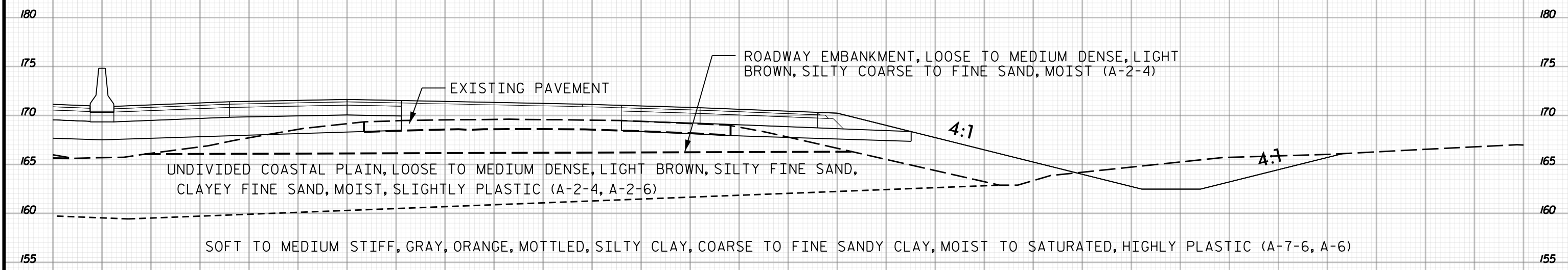

470+50

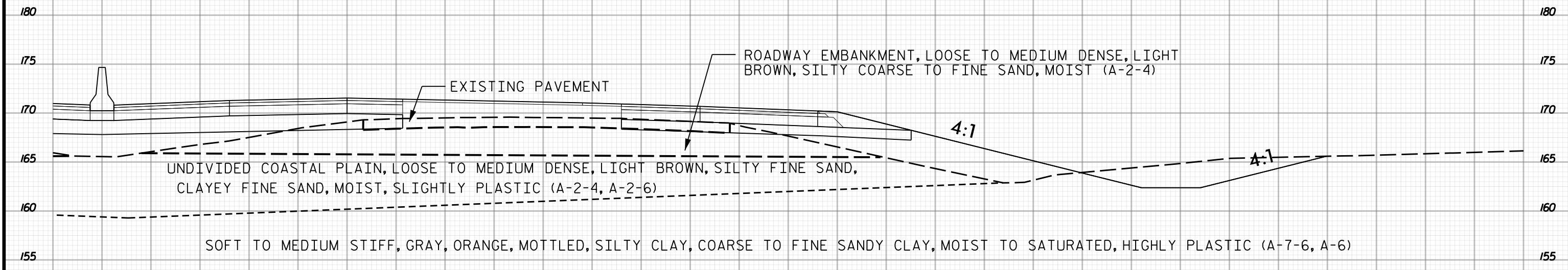

470+00
2 OF 2

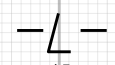

5 0 5 10 15 20 25 30 35 40 45 50 55 60 65 70 75 80 85 90 95 100 105 110 115 120 125 130 135 140 145



140 135 130 125 120 115 110 105 100 95 90 85 80 75 70 65 60 55 50 45 40 35 30 25 20 15 10 5 0 5

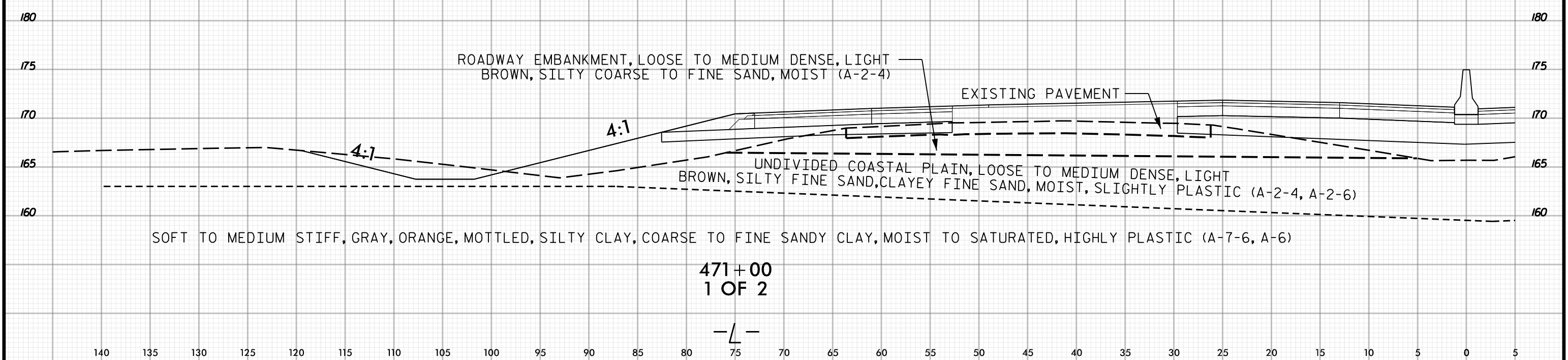
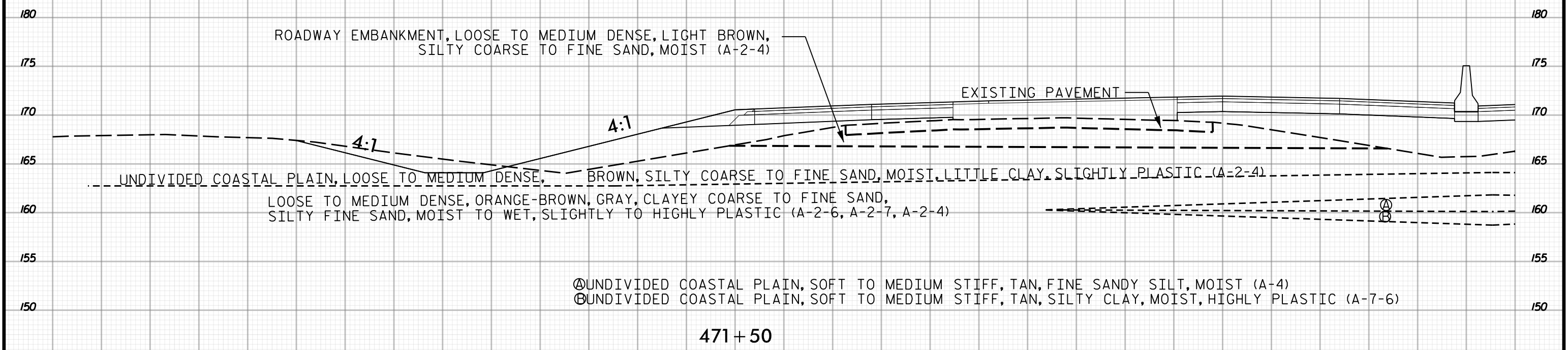

140 135 130 125 120 115 110 105 100 95 90 85 80 75 70 65 60 55 50 45 40 35 30 25 20 15 10 5 0 5



5 0 5 10 15 20 25 30 35 40 45 50 55 60 65 70 75 80 85 90 95 100 105 110 115 120 125 130 135 140 145

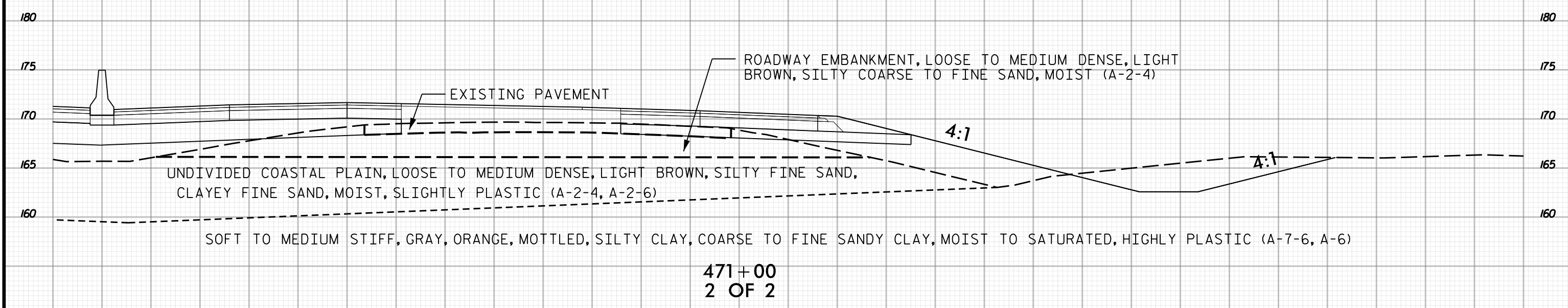
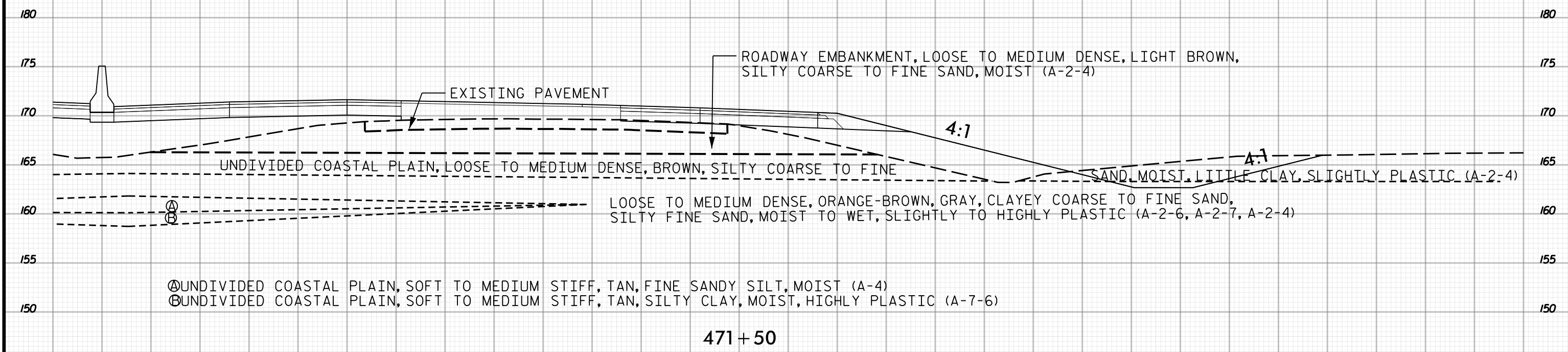

5 0 5 10 15 20 25 30 35 40 45 50 55 60 65 70 75 80 85 90 95 100 105 110 115 120 125 130 135 140 145



140 135 130 125 120 115 110 105 100 95 90 85 80 75 70 65 60 55 50 45 40 35 30 25 20 15 10 5 0 5

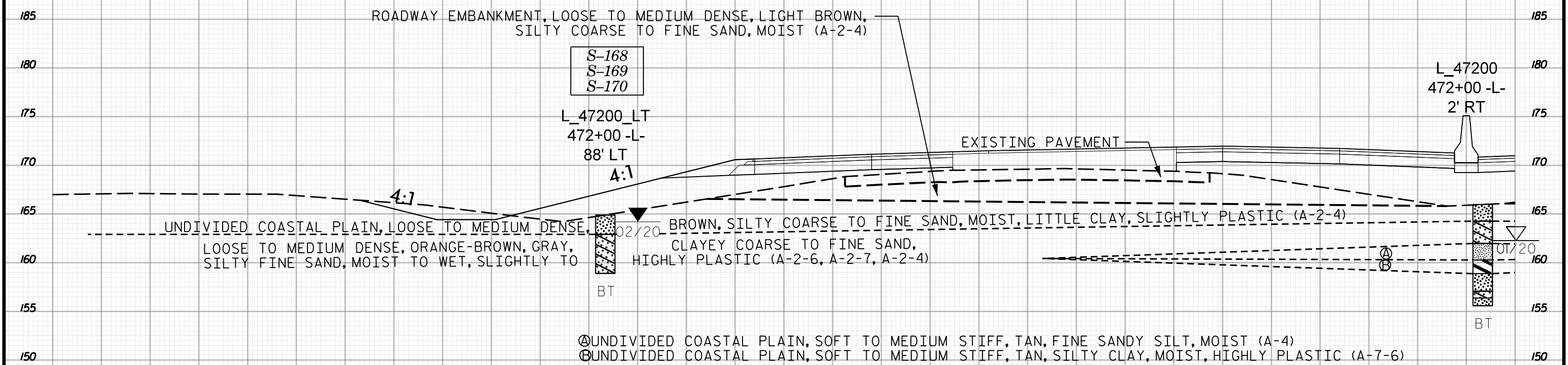
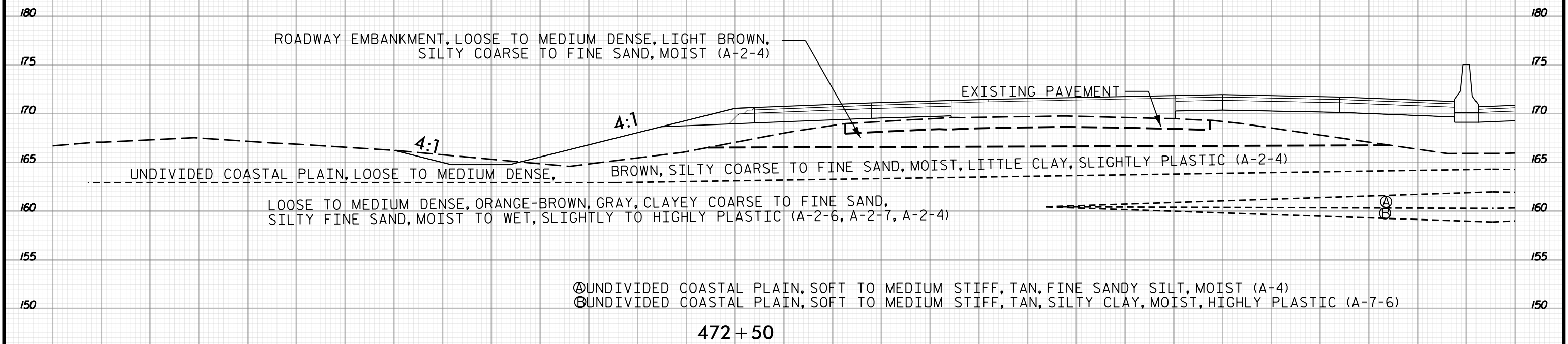

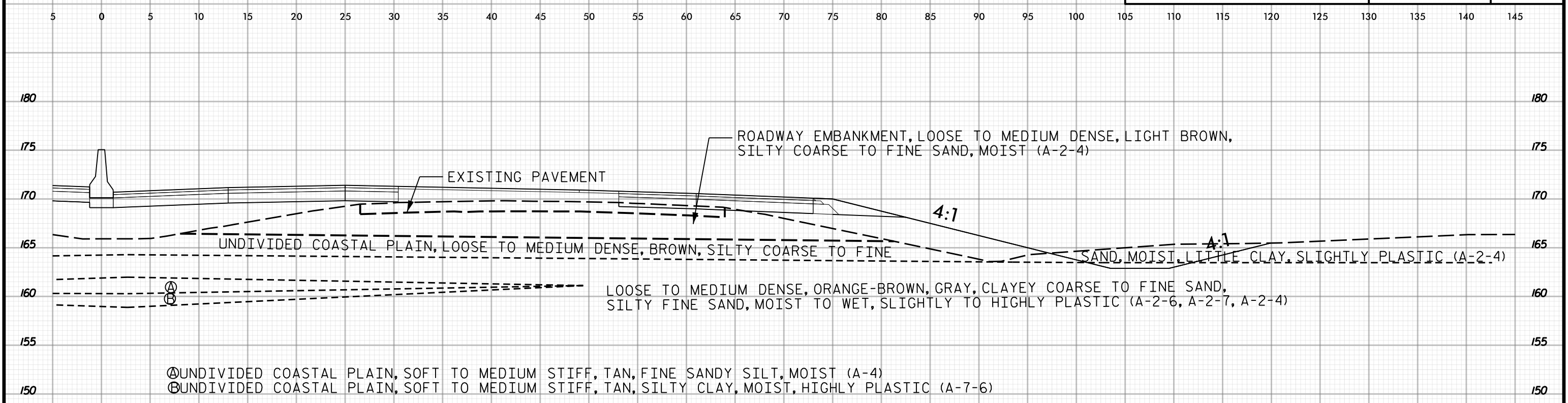
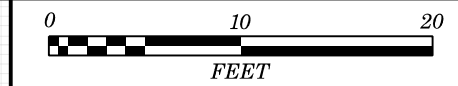

472 + 50

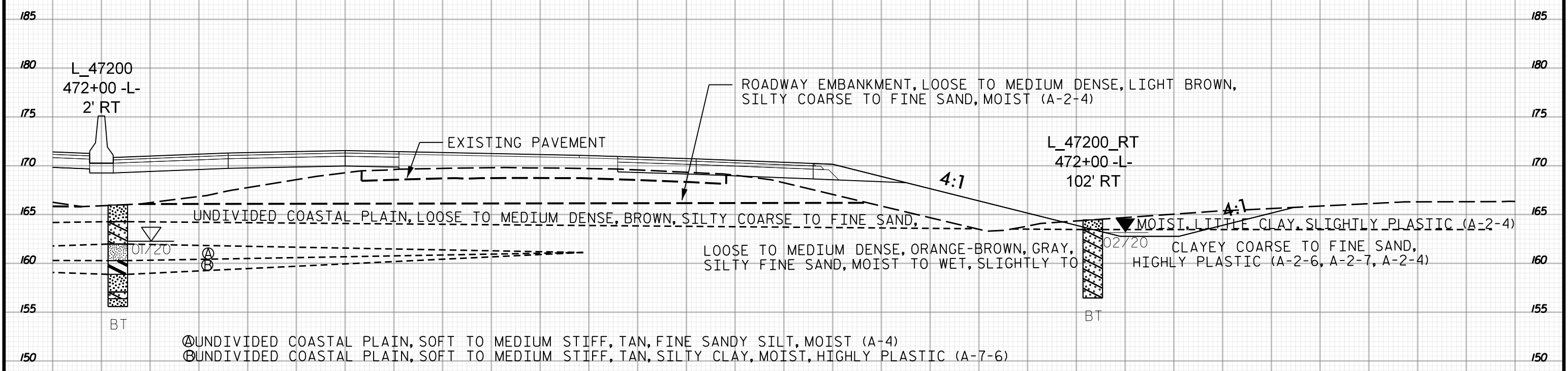

472 + 00
2 OF 2

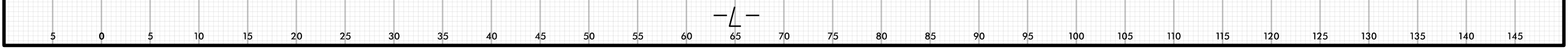



140 135 130 125 120 115 110 105 100 95 90 85 80 75 70 65 60 55 50 45 40 35 30 25 20 15 10 5 0 5

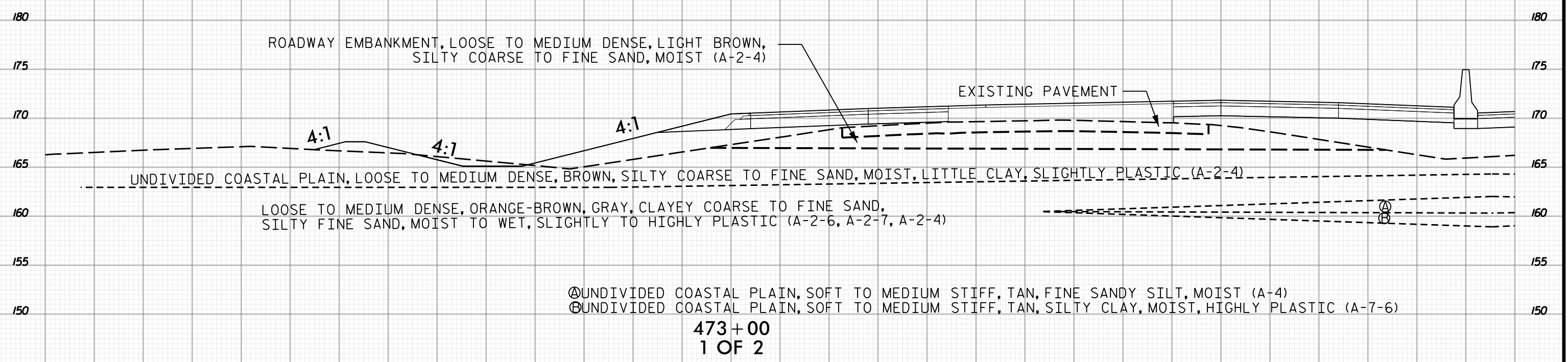
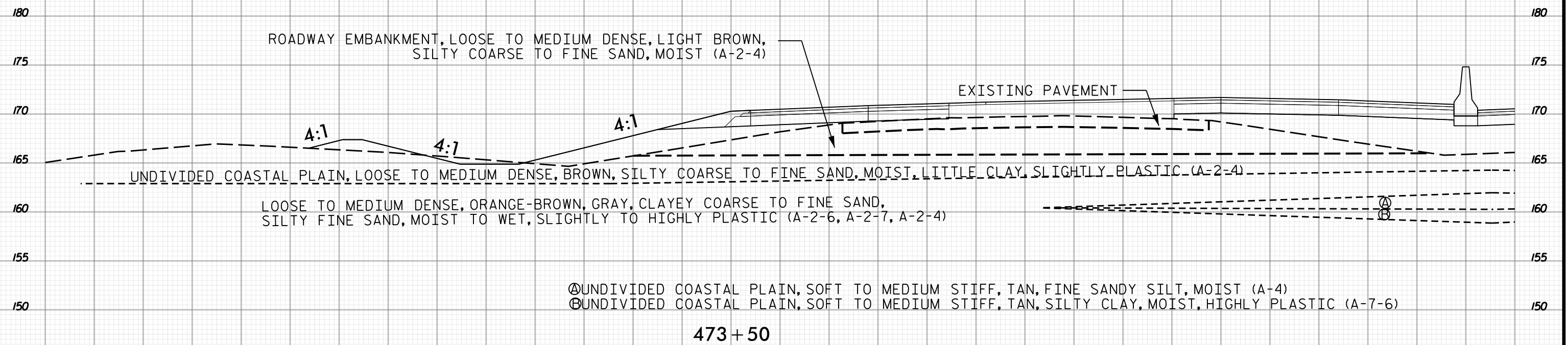

140 135 130 125 120 115 110 105 100 95 90 85 80 75 70 65 60 55 50 45 40 35 30 25 20 15 10 5 0 5



5 0 5 10 15 20 25 30 35 40 45 50 55 60 65 70 75 80 85 90 95 100 105 110 115 120 125 130 135 140 145

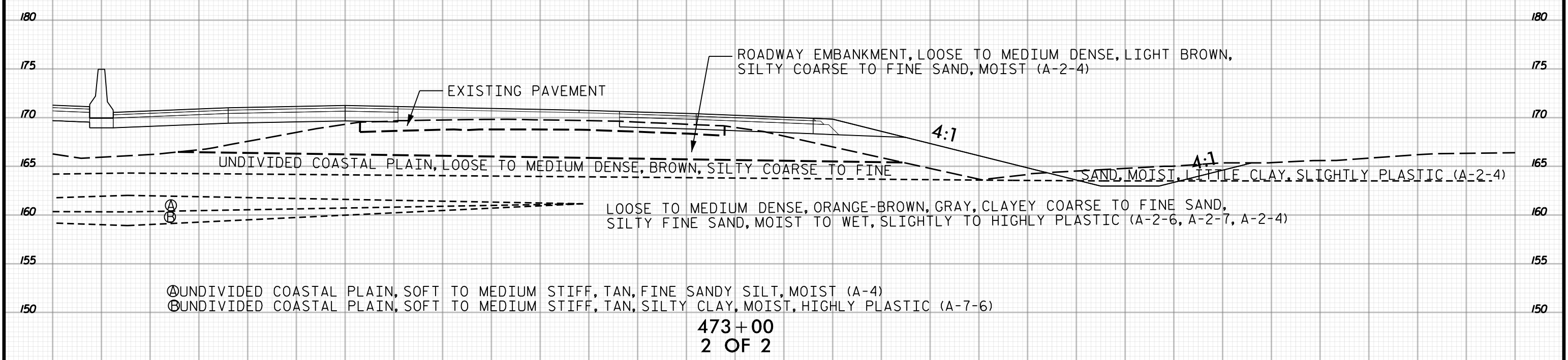
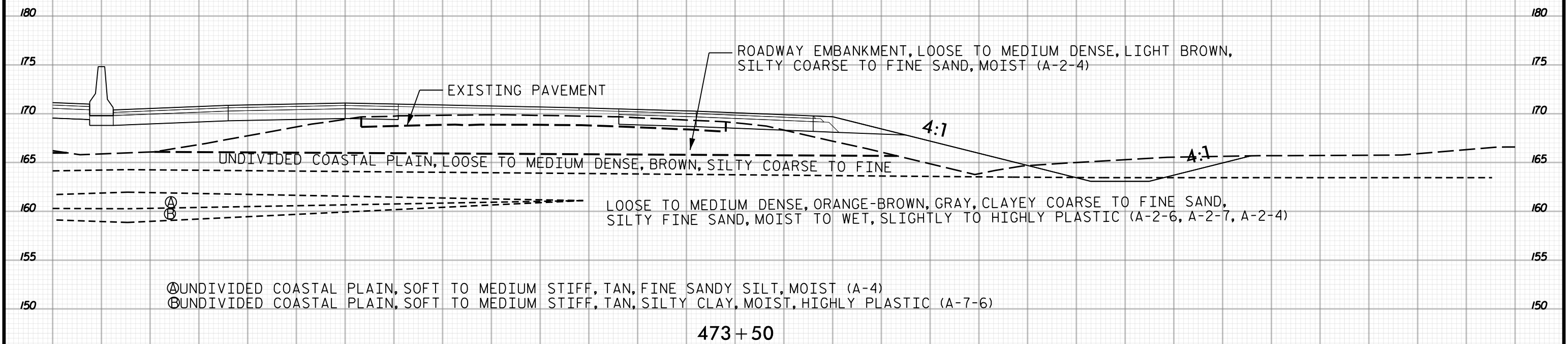

5 0 5 10 15 20 25 30 35 40 45 50 55 60 65 70 75 80 85 90 95 100 105 110 115 120 125 130 135 140 145



140 135 130 125 120 115 110 105 100 95 90 85 80 75 70 65 60 55 50 45 40 35 30 25 20 15 10 5 0 5

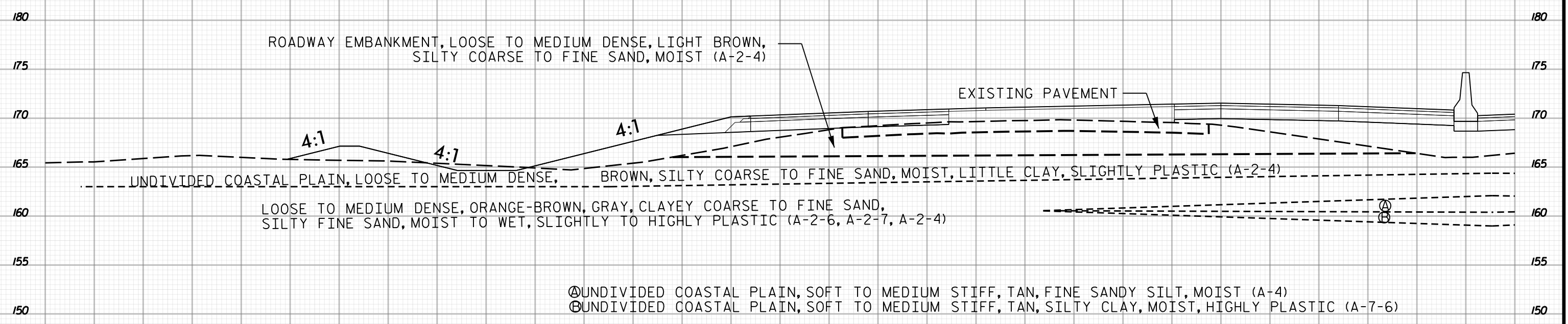
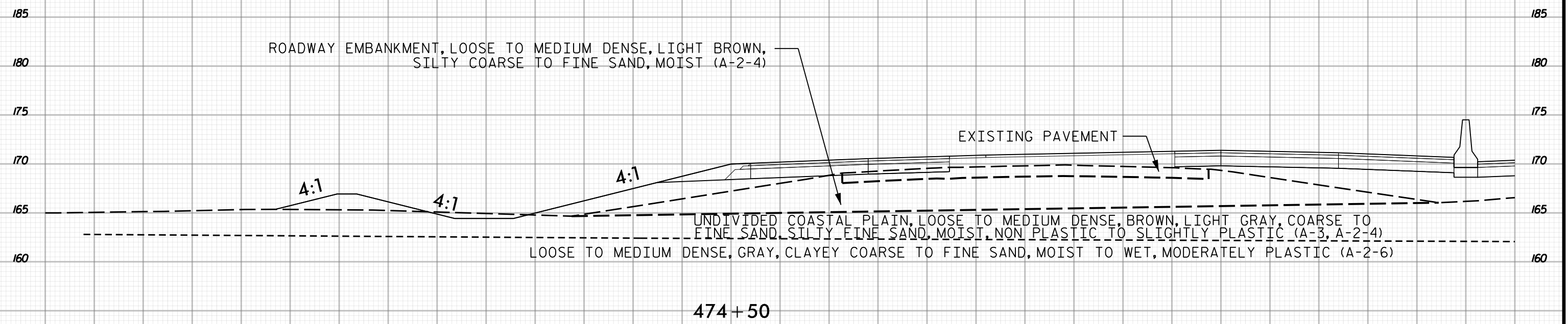

140 135 130 125 120 115 110 105 100 95 90 85 80 75 70 65 60 55 50 45 40 35 30 25 20 15 10 5 0 5



5 0 5 10 15 20 25 30 35 40 45 50 55 60 65 70 75 80 85 90 95 100 105 110 115 120 125 130 135 140 145

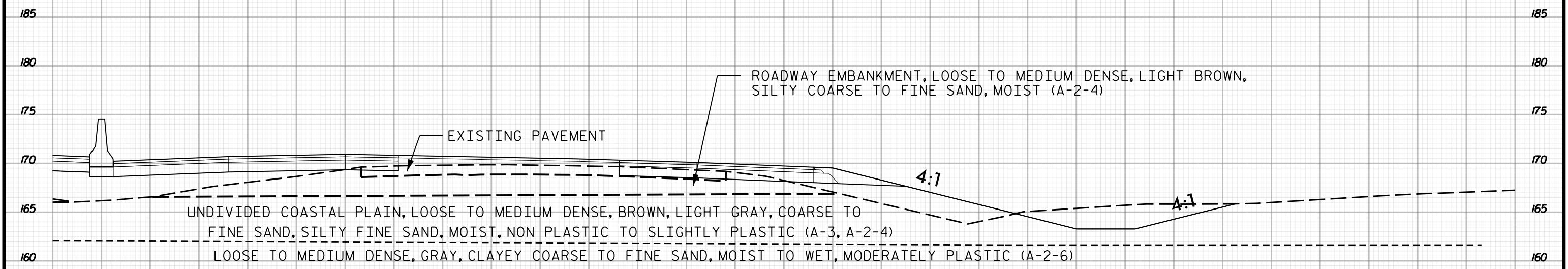

474+50

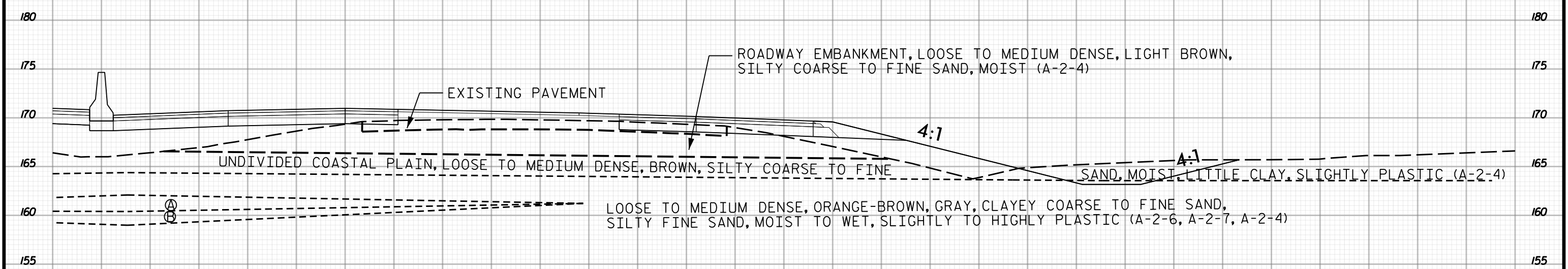

- Ⓐ UNDIVIDED COASTAL PLAIN, SOFT TO MEDIUM STIFF, TAN, FINE SANDY SILT, MOIST (A-4)
- Ⓑ UNDIVIDED COASTAL PLAIN, SOFT TO MEDIUM STIFF, TAN, SILTY CLAY, MOIST, HIGHLY PLASTIC (A-7-6)

474+00
2 OF 2

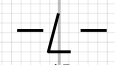

5 0 5 10 15 20 25 30 35 40 45 50 55 60 65 70 75 80 85 90 95 100 105 110 115 120 125 130 135 140 145

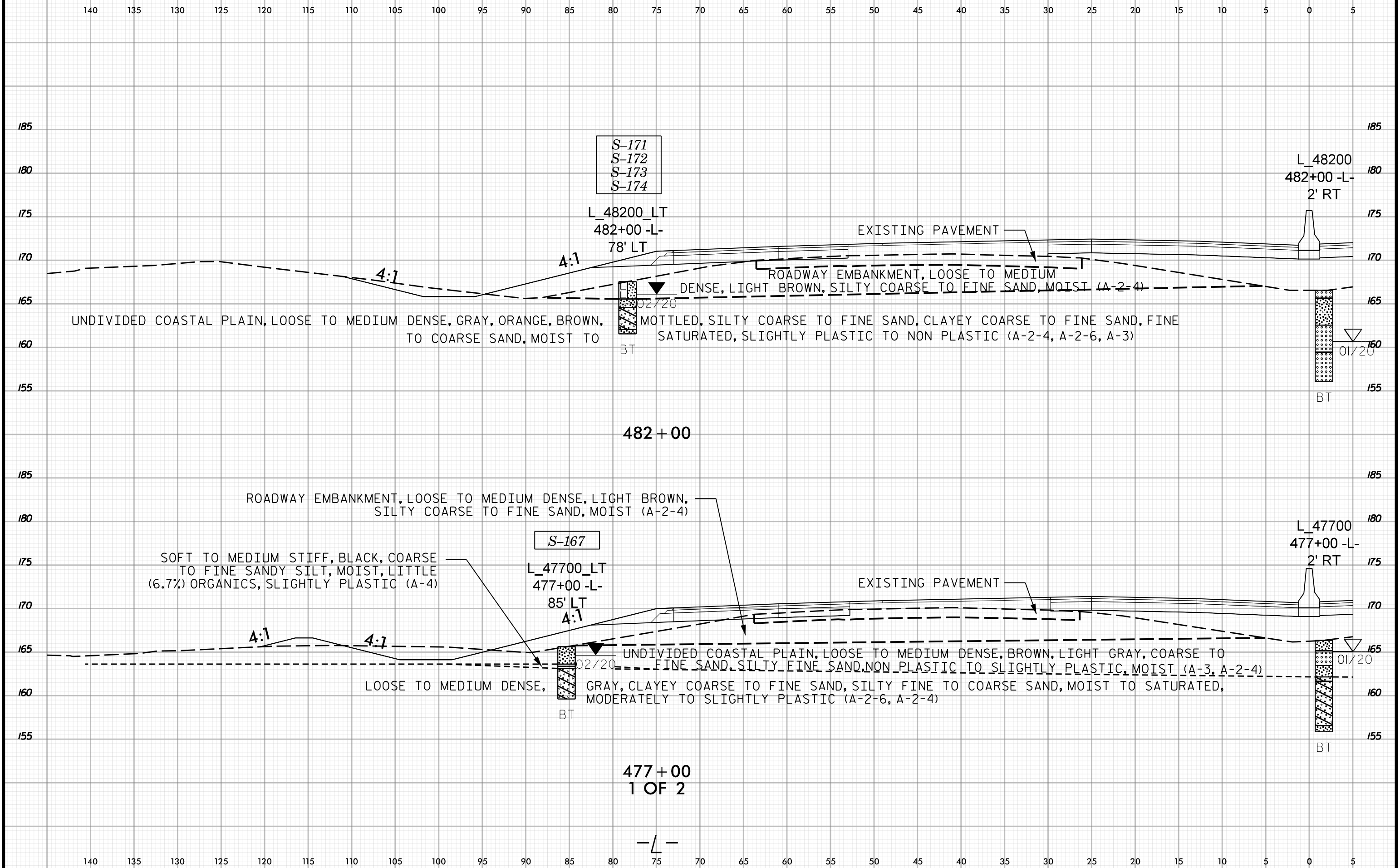
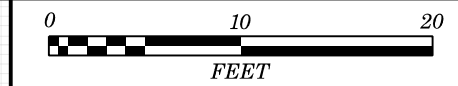

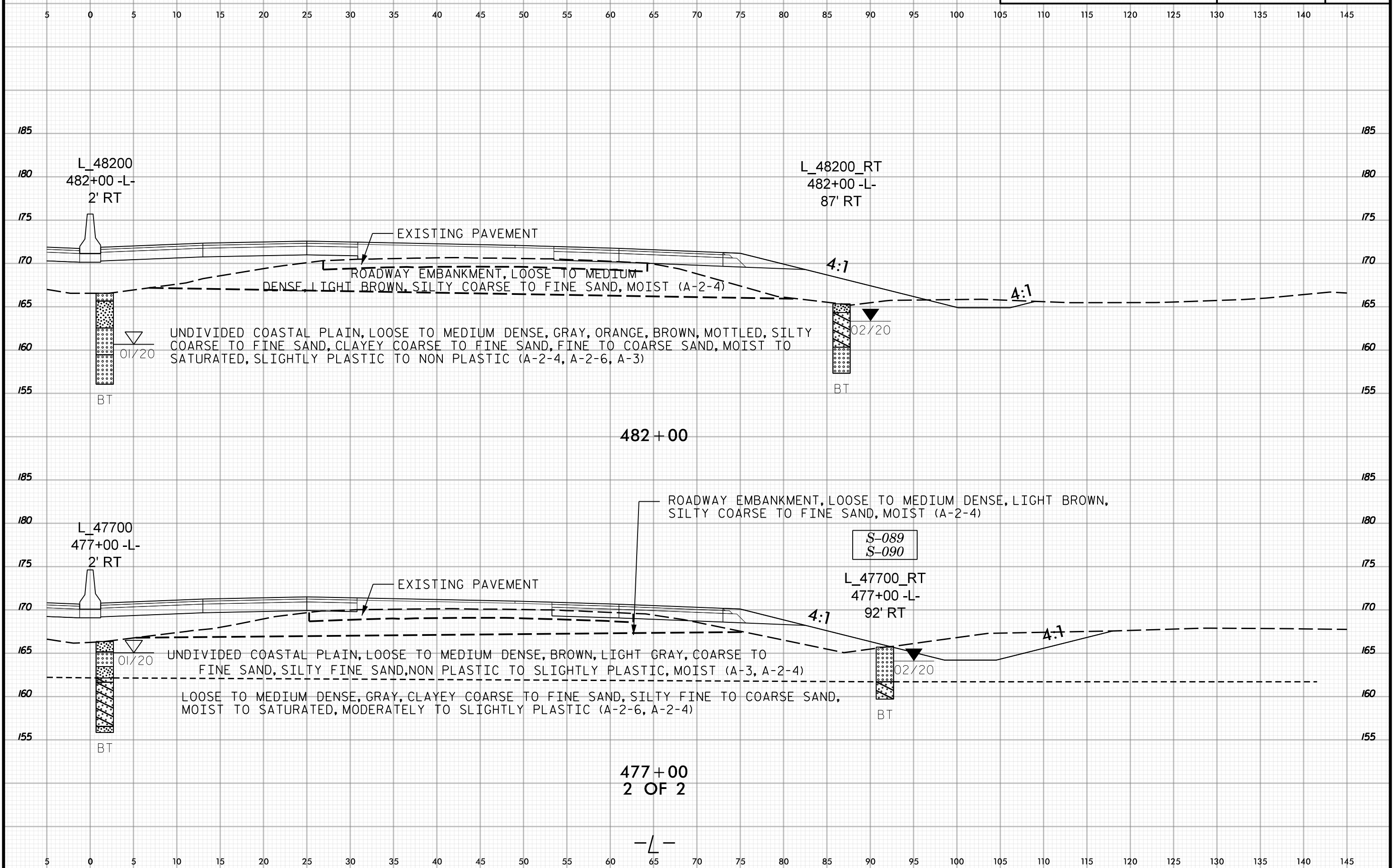
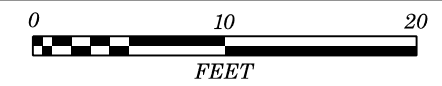

477+00
2 OF 2

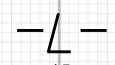



140 135 130 125 120 115 110 105 100 95 90 85 80 75 70 65 60 55 50 45 40 35 30 25 20 15 10 5 0 5

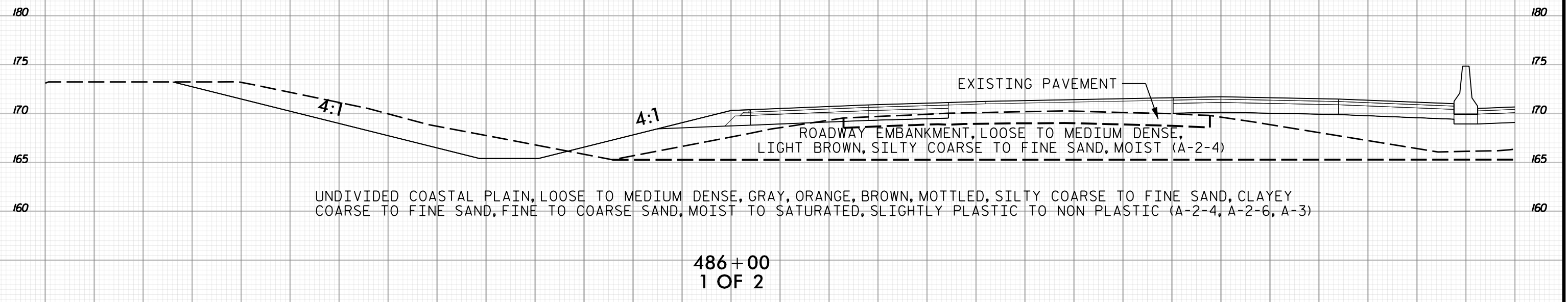
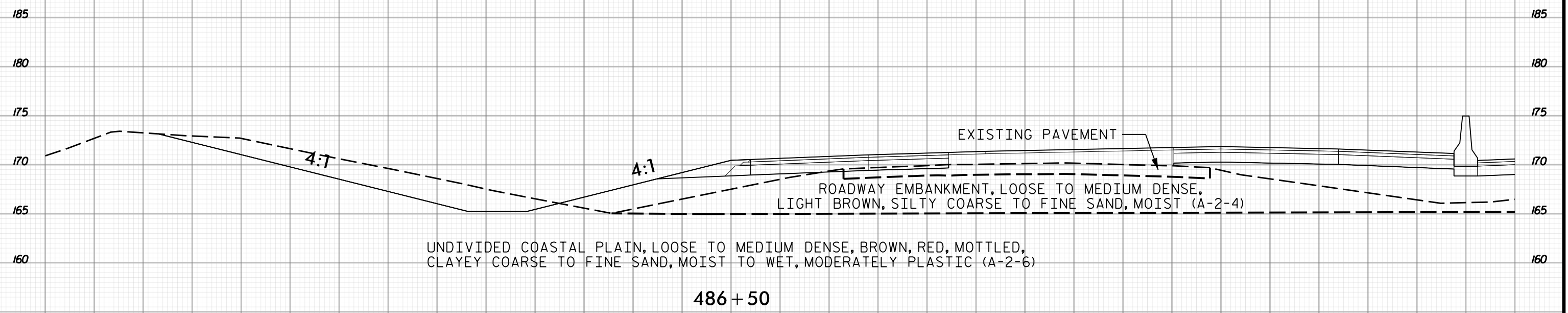

140 135 130 125 120 115 110 105 100 95 90 85 80 75 70 65 60 55 50 45 40 35 30 25 20 15 10 5 0 5

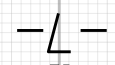



5 0 5 10 15 20 25 30 35 40 45 50 55 60 65 70 75 80 85 90 95 100 105 110 115 120 125 130 135 140 145

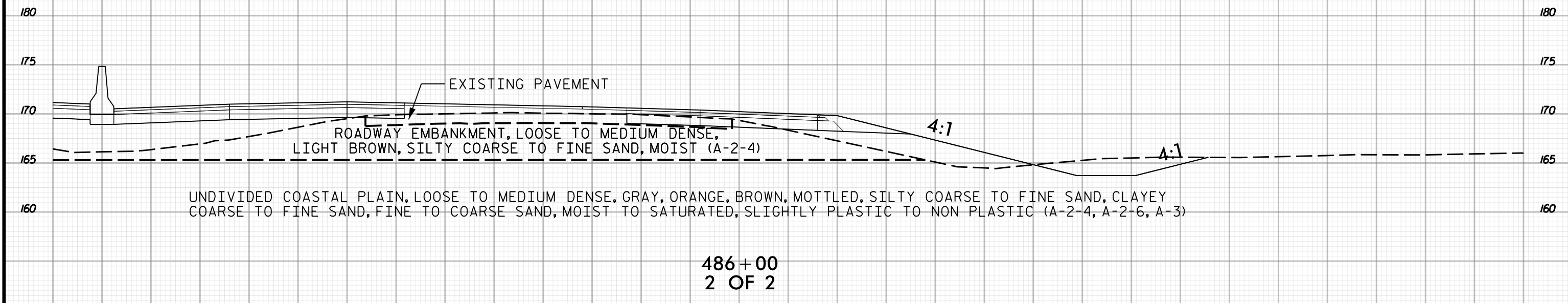
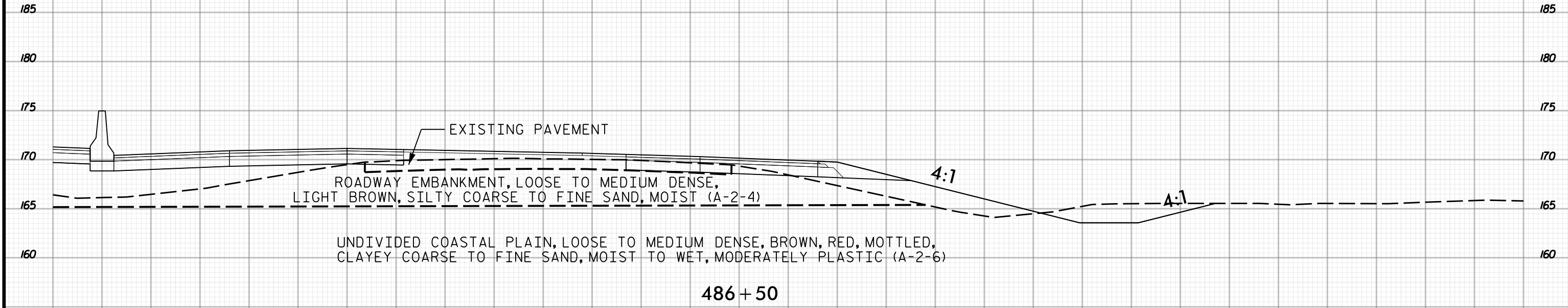

5 0 5 10 15 20 25 30 35 40 45 50 55 60 65 70 75 80 85 90 95 100 105 110 115 120 125 130 135 140 145

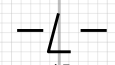



140 135 130 125 120 115 110 105 100 95 90 85 80 75 70 65 60 55 50 45 40 35 30 25 20 15 10 5 0 5

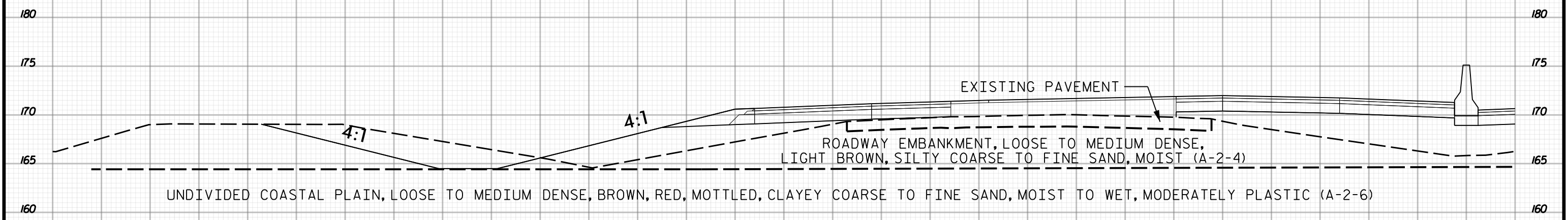

487+50

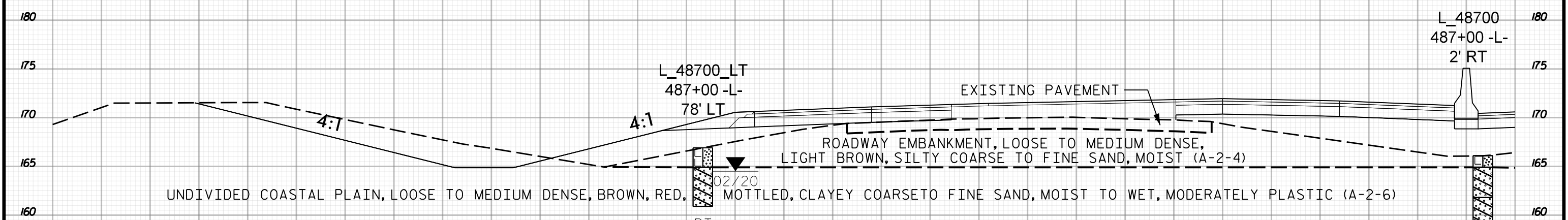

487+00
1 OF 2

140 135 130 125 120 115 110 105 100 95 90 85 80 75 70 65 60 55 50 45 40 35 30 25 20 15 10 5 0 5



5 0 5 10 15 20 25 30 35 40 45 50 55 60 65 70 75 80 85 90 95 100 105 110 115 120 125 130 135 140 145

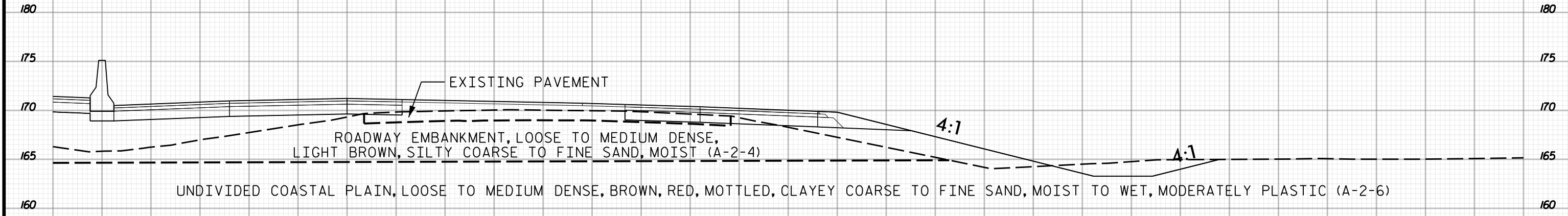

487+50

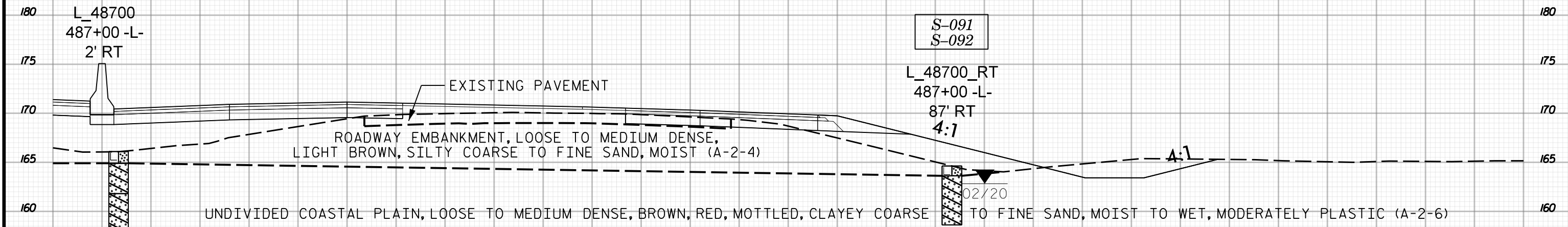

487+00
2 OF 2

5 0 5 10 15 20 25 30 35 40 45 50 55 60 65 70 75 80 85 90 95 100 105 110 115 120 125 130 135 140 145

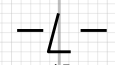



140 135 130 125 120 115 110 105 100 95 90 85 80 75 70 65 60 55 50 45 40 35 30 25 20 15 10 5 0 5

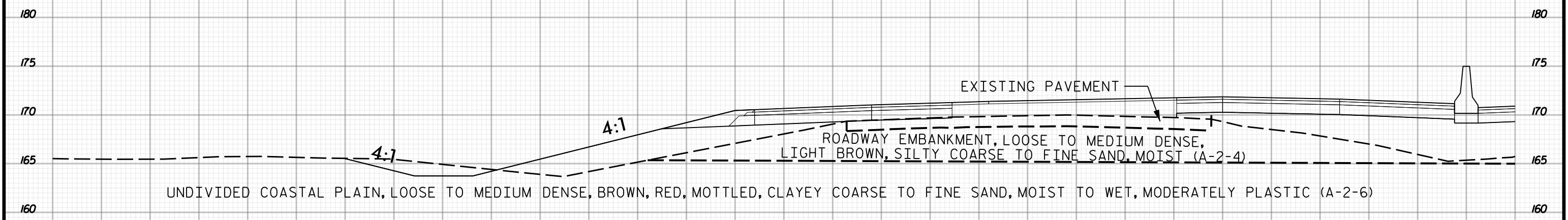

488+50

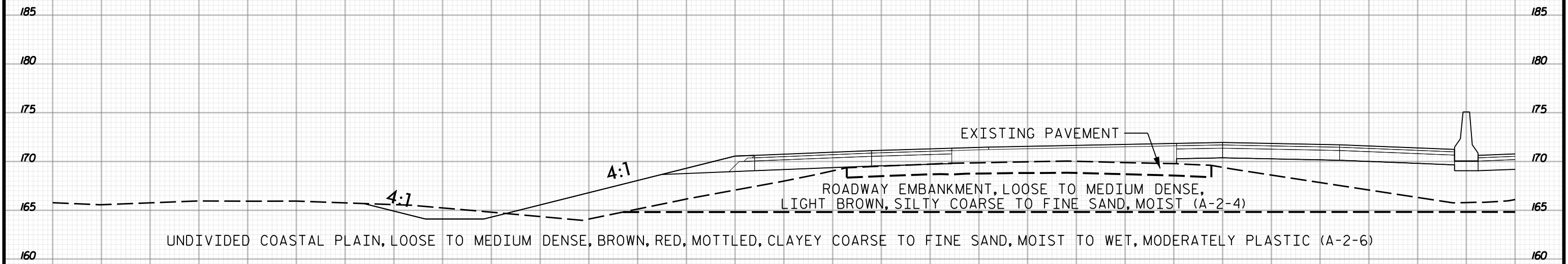

488+00
1 OF 2

140 135 130 125 120 115 110 105 100 95 90 85 80 75 70 65 60 55 50 45 40 35 30 25 20 15 10 5 0 5

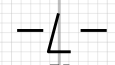



5 0 5 10 15 20 25 30 35 40 45 50 55 60 65 70 75 80 85 90 95 100 105 110 115 120 125 130 135 140 145

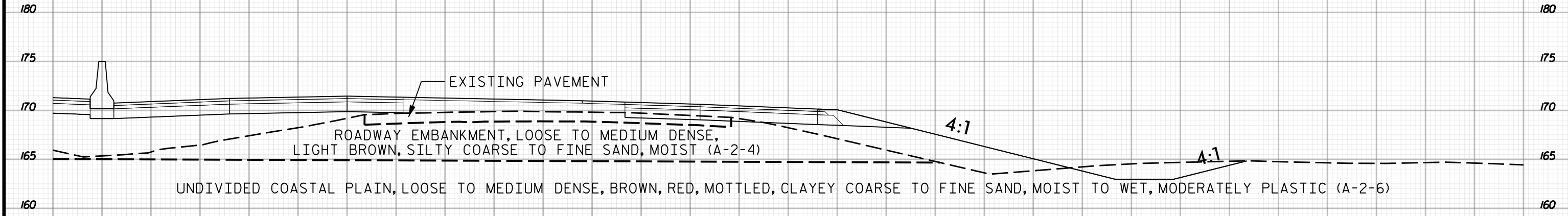

488 + 50

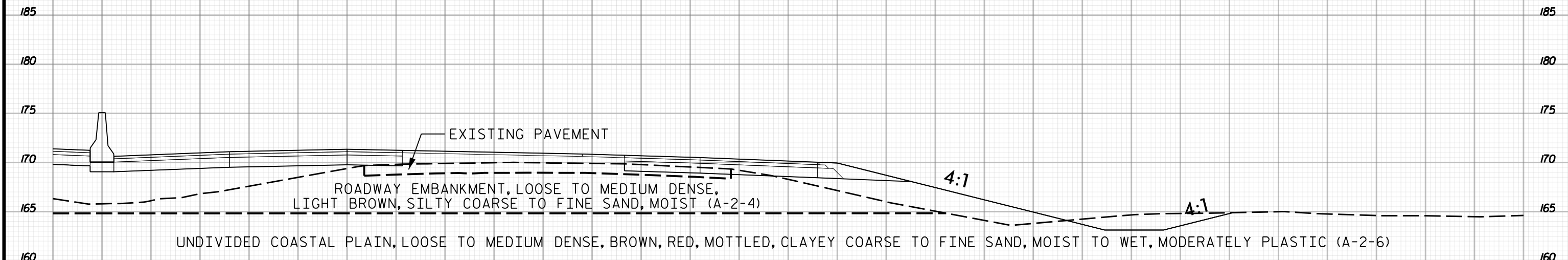

488 + 00
2 OF 2

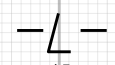

5 0 5 10 15 20 25 30 35 40 45 50 55 60 65 70 75 80 85 90 95 100 105 110 115 120 125 130 135 140 145

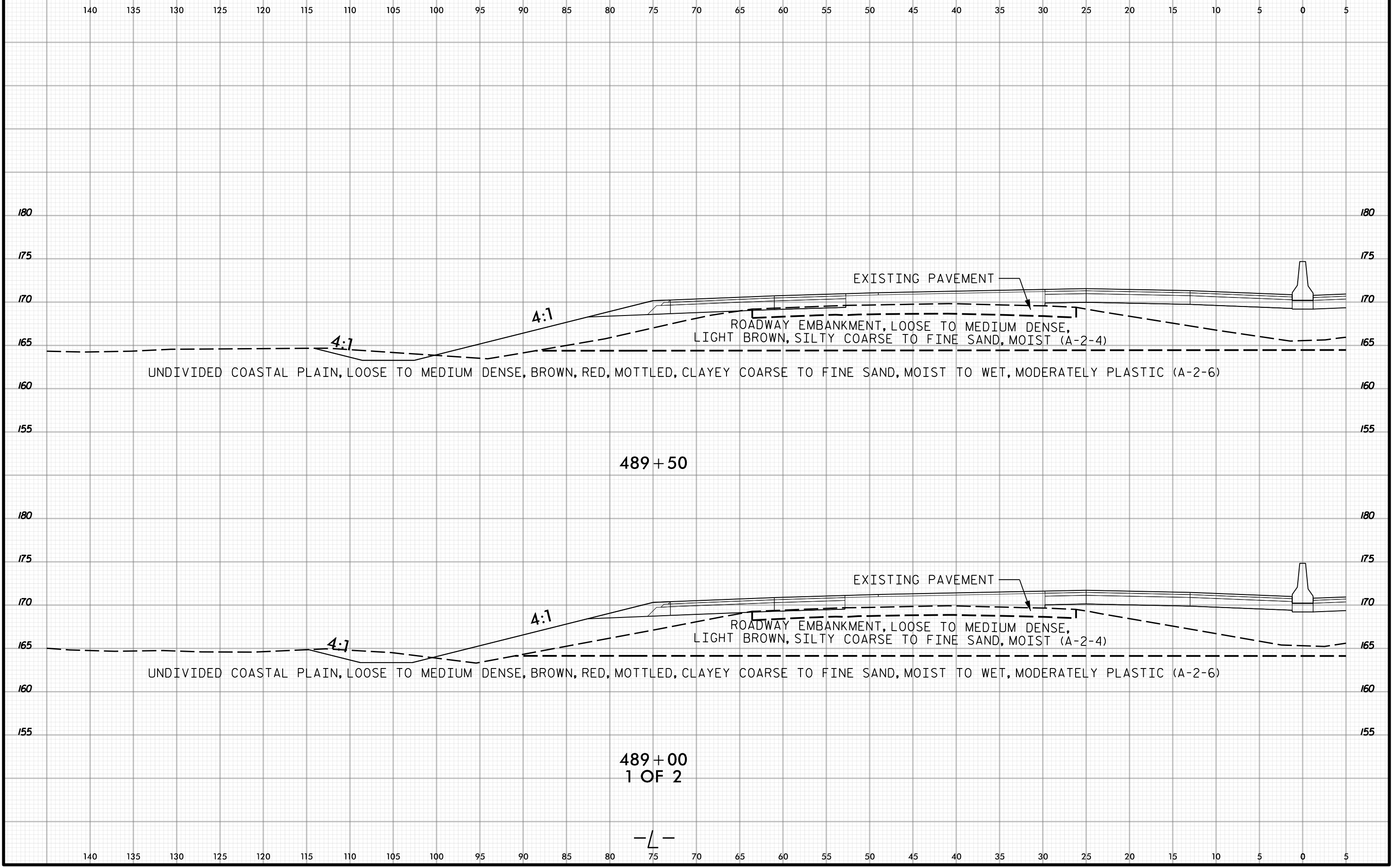

489 + 00
1 OF 2

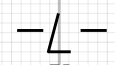

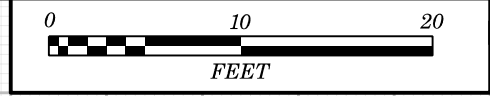

PROJ. REFERENCE NO.	SHEET NO.
I-5987A	891

5 0 5 10 15 20 25 30 35 40 45 50 55 60 65 70 75 80 85 90 95 100 105 110 115 120 125 130 135 140 145

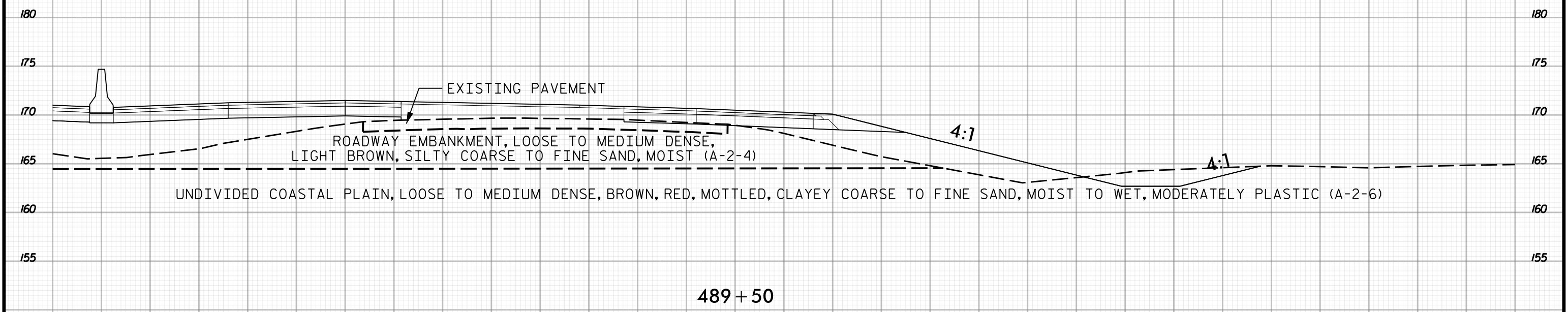

489 + 50

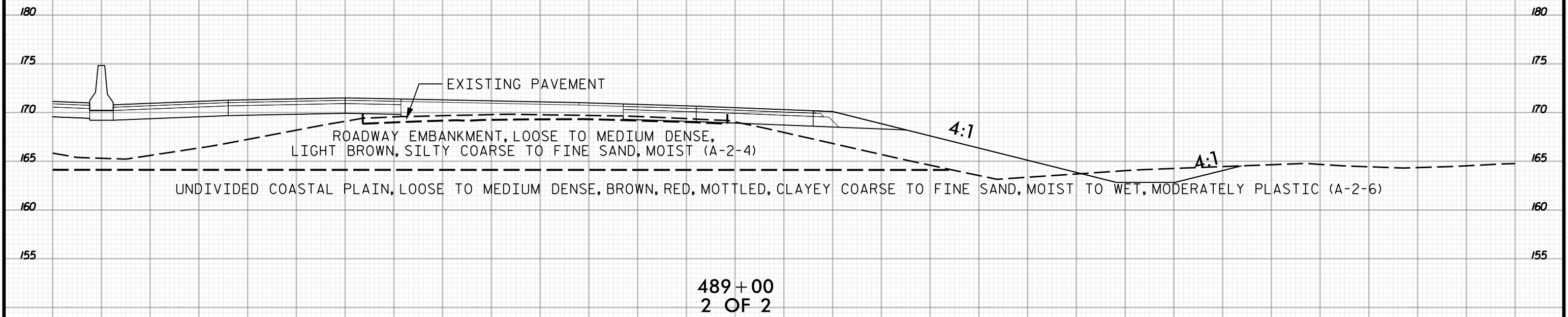

489 + 00
2 OF 2

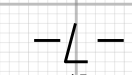

5 0 5 10 15 20 25 30 35 40 45 50 55 60 65 70 75 80 85 90 95 100 105 110 115 120 125 130 135 140 145

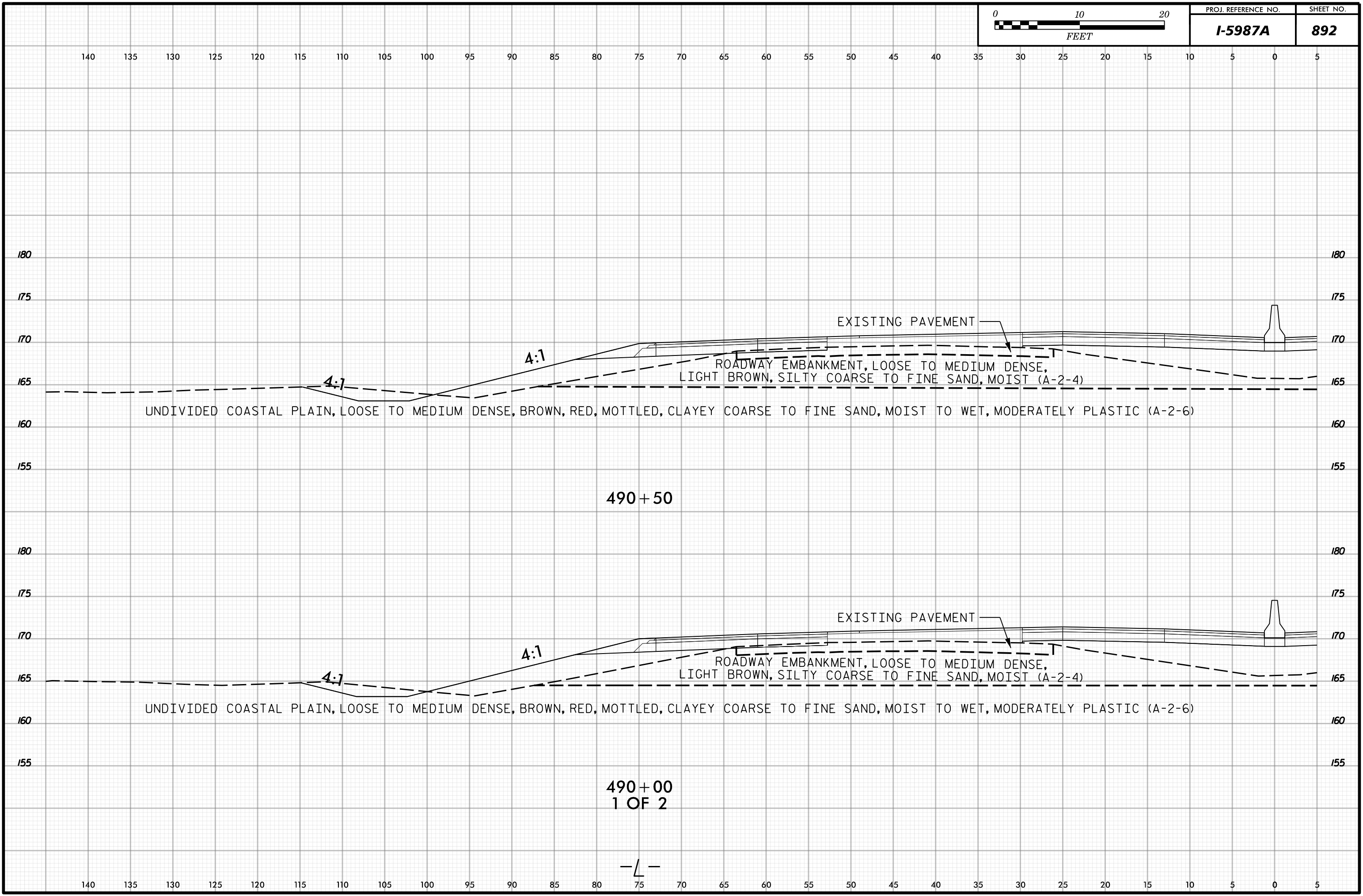

490+50

490+00
1 OF 2

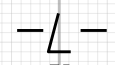



PROJ. REFERENCE NO.	SHEET NO.
I-5987A	893

5 0 5 10 15 20 25 30 35 40 45 50 55 60 65 70 75 80 85 90 95 100 105 110 115 120 125 130 135 140 145

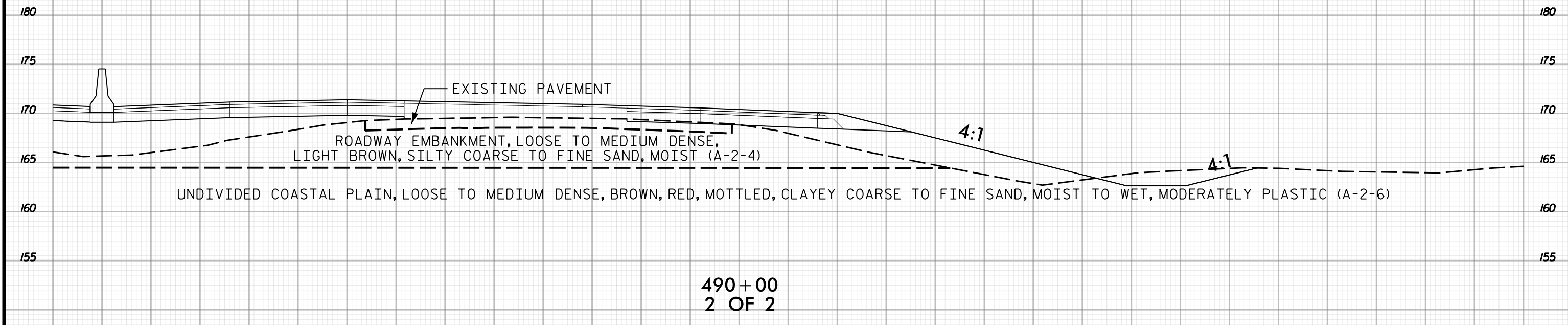
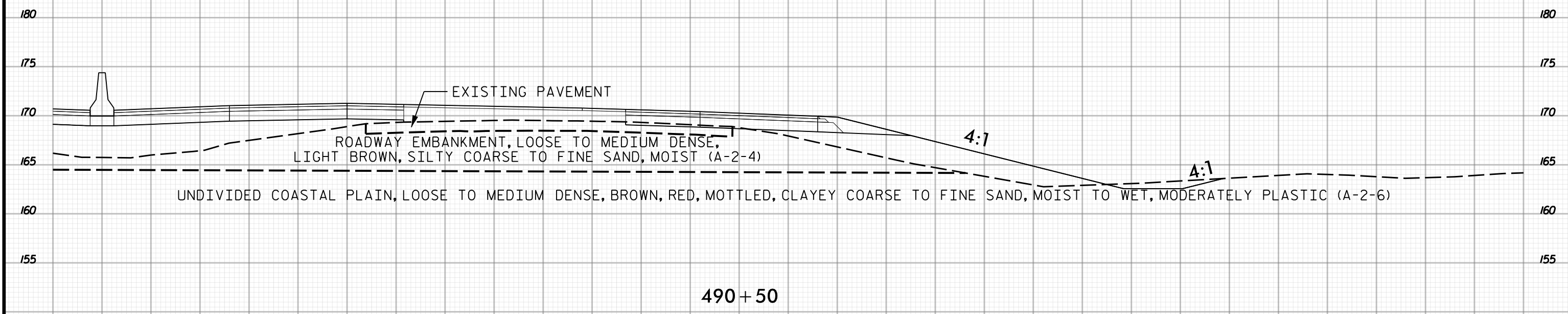

5 0 5 10 15 20 25 30 35 40 45 50 55 60 65 70 75 80 85 90 95 100 105 110 115 120 125 130 135 140 145

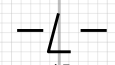



140 135 130 125 120 115 110 105 100 95 90 85 80 75 70 65 60 55 50 45 40 35 30 25 20 15 10 5 0 5

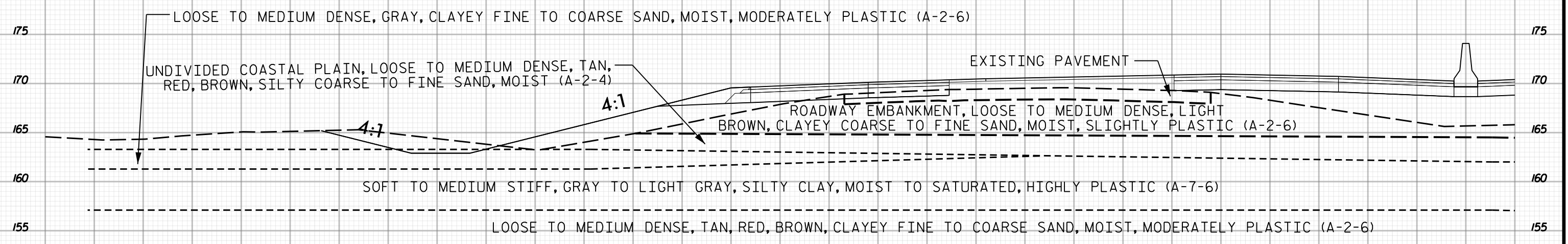

491+50

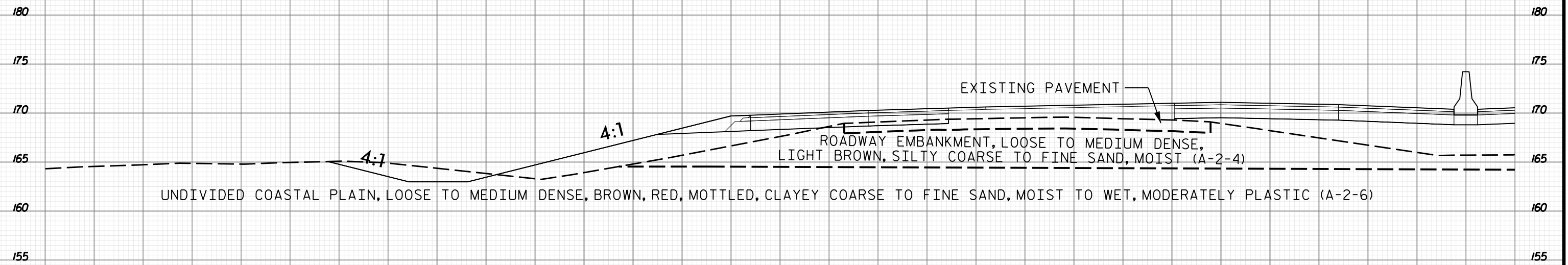

491+00
1 OF 2

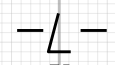

140 135 130 125 120 115 110 105 100 95 90 85 80 75 70 65 60 55 50 45 40 35 30 25 20 15 10 5 0 5

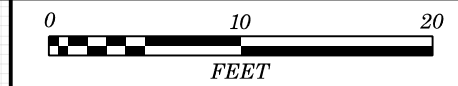

5 0 5 10 15 20 25 30 35 40 45 50 55 60 65 70 75 80 85 90 95 100 105 110 115 120 125 130 135 140 145

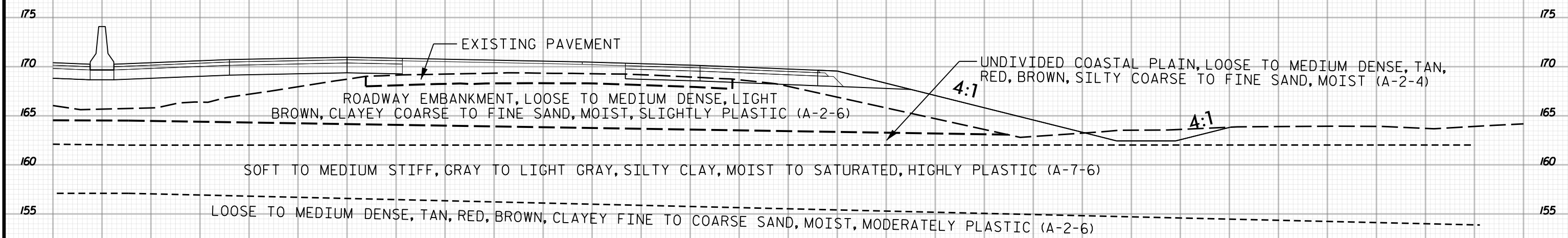

491+50

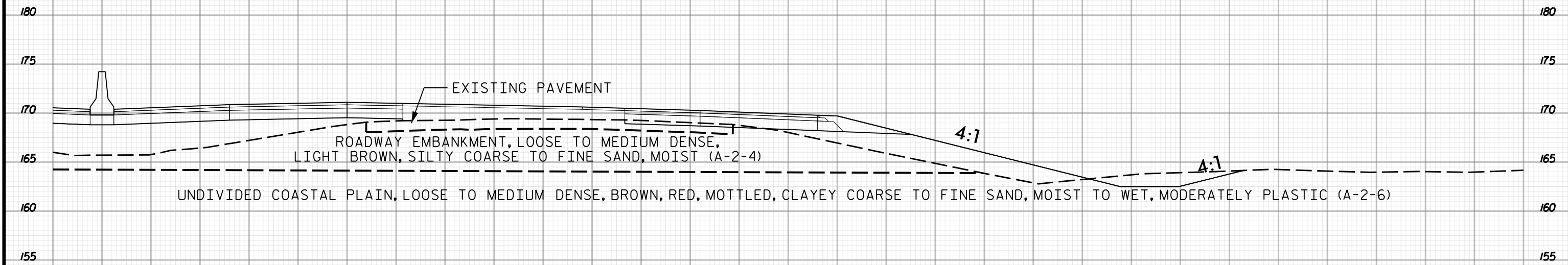

491+00
2 OF 2

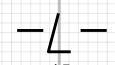

5 0 5 10 15 20 25 30 35 40 45 50 55 60 65 70 75 80 85 90 95 100 105 110 115 120 125 130 135 140 145



140 135 130 125 120 115 110 105 100 95 90 85 80 75 70 65 60 55 50 45 40 35 30 25 20 15 10 5 0 5

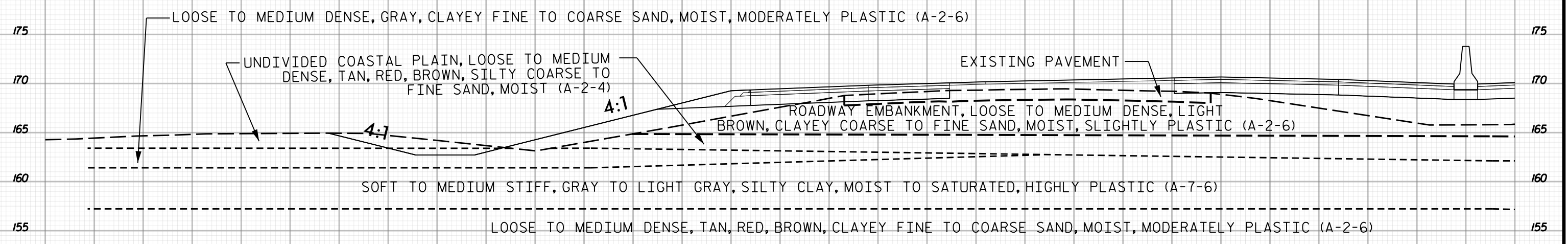

492 + 50

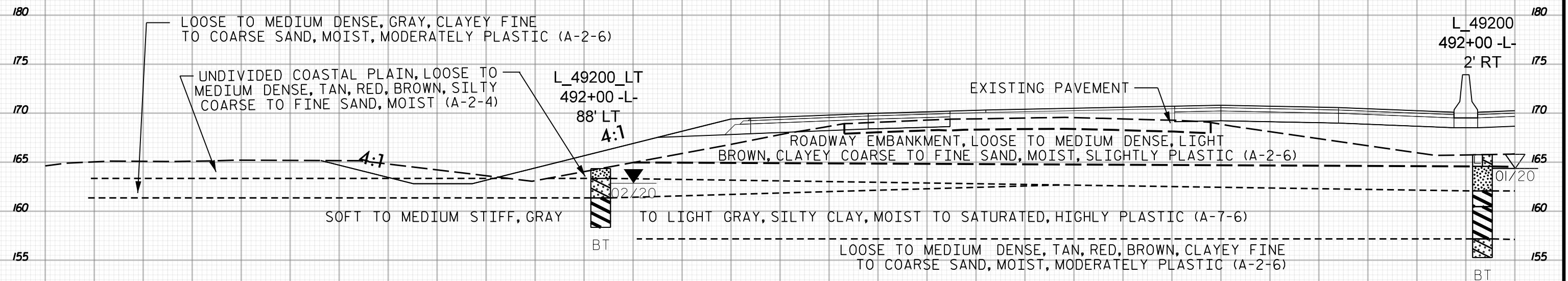

492 + 00
1 OF 2

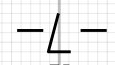

140 135 130 125 120 115 110 105 100 95 90 85 80 75 70 65 60 55 50 45 40 35 30 25 20 15 10 5 0 5

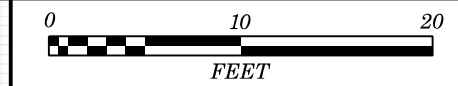

5 0 5 10 15 20 25 30 35 40 45 50 55 60 65 70 75 80 85 90 95 100 105 110 115 120 125 130 135 140 145

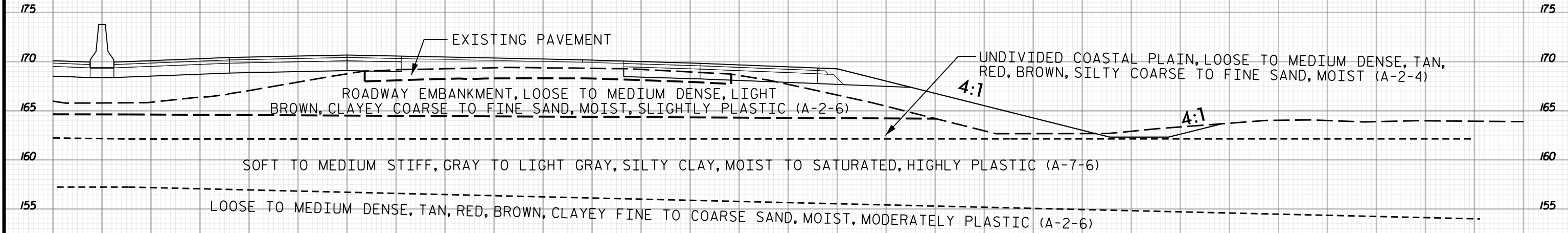

492 + 50

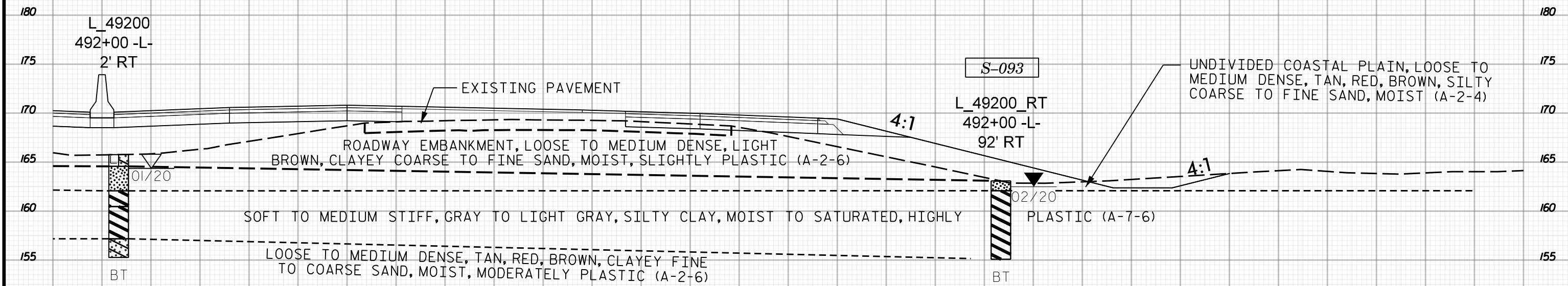

492 + 00
2 OF 2

5 0 5 10 15 20 25 30 35 40 45 50 55 60 65 70 75 80 85 90 95 100 105 110 115 120 125 130 135 140 145



140 135 130 125 120 115 110 105 100 95 90 85 80 75 70 65 60 55 50 45 40 35 30 25 20 15 10 5 0 5

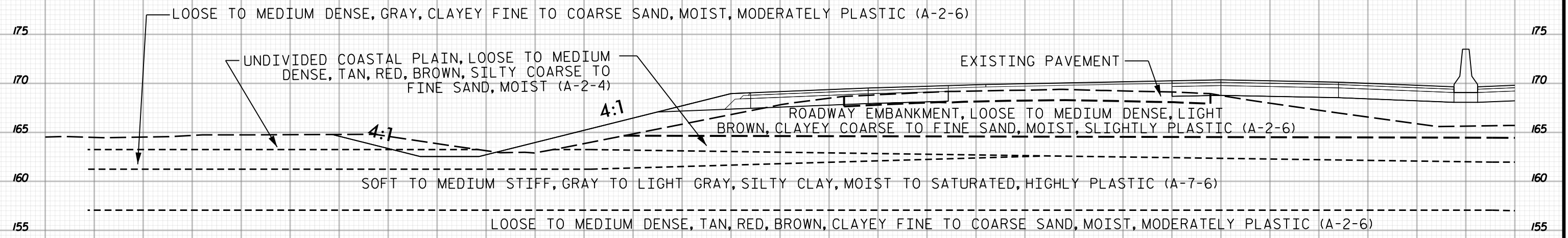

493 + 50

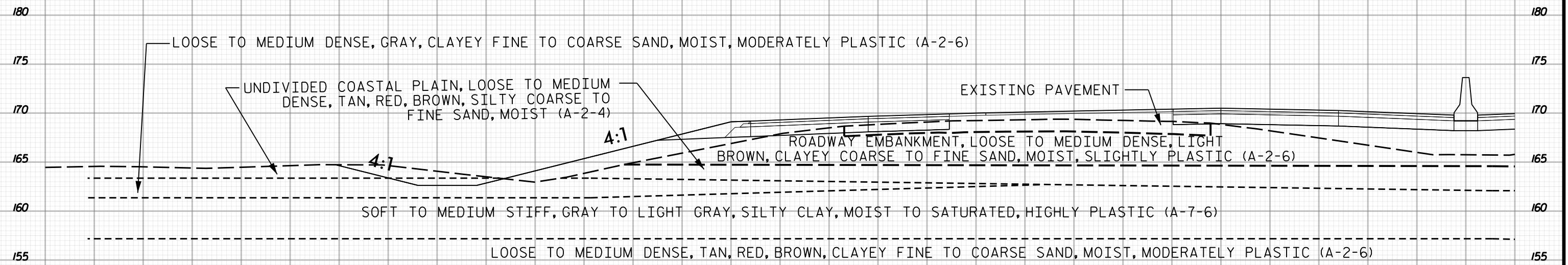

493 + 00
1 OF 2

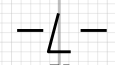

140 135 130 125 120 115 110 105 100 95 90 85 80 75 70 65 60 55 50 45 40 35 30 25 20 15 10 5 0 5

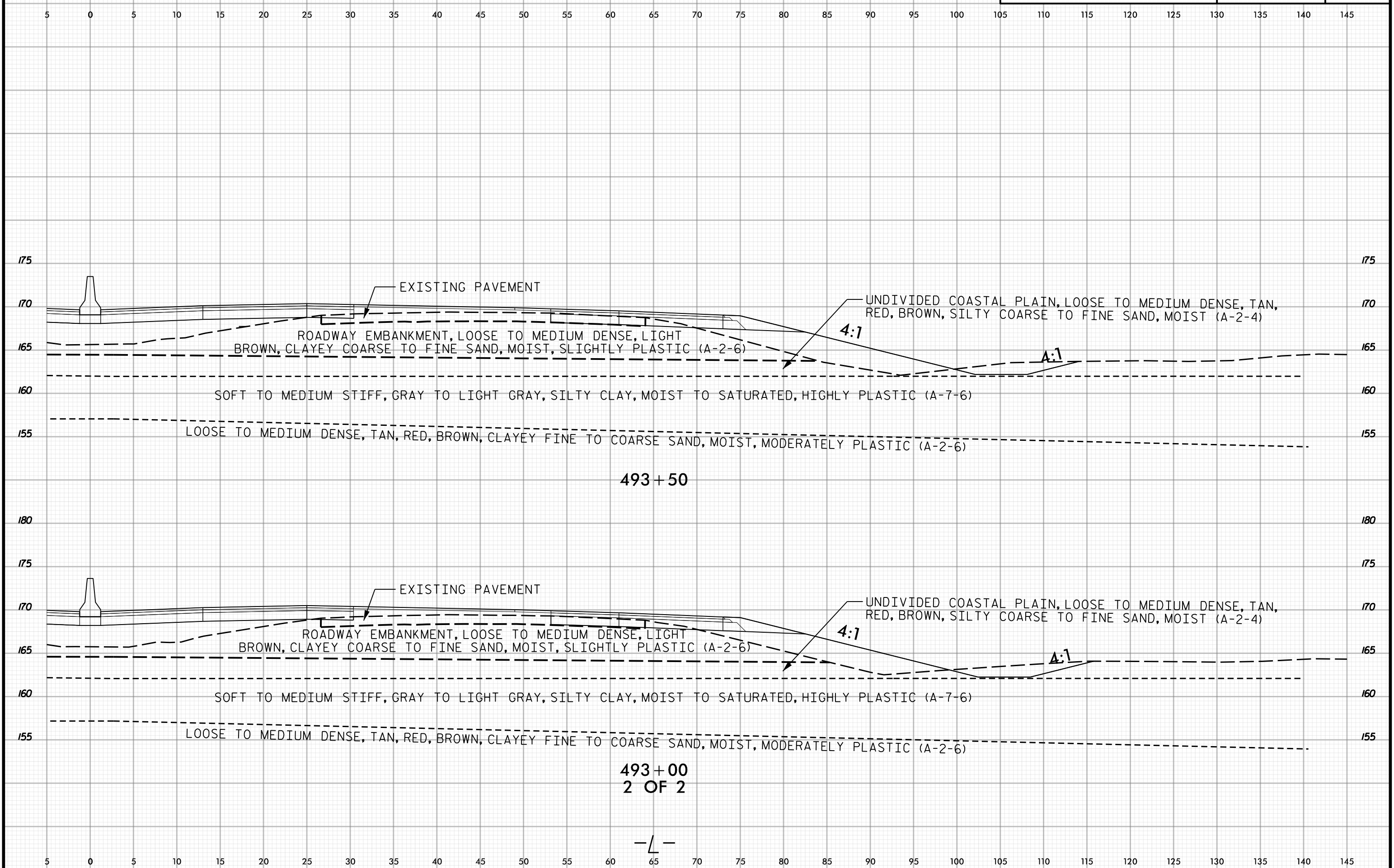



140 135 130 125 120 115 110 105 100 95 90 85 80 75 70 65 60 55 50 45 40 35 30 25 20 15 10 5 0 5

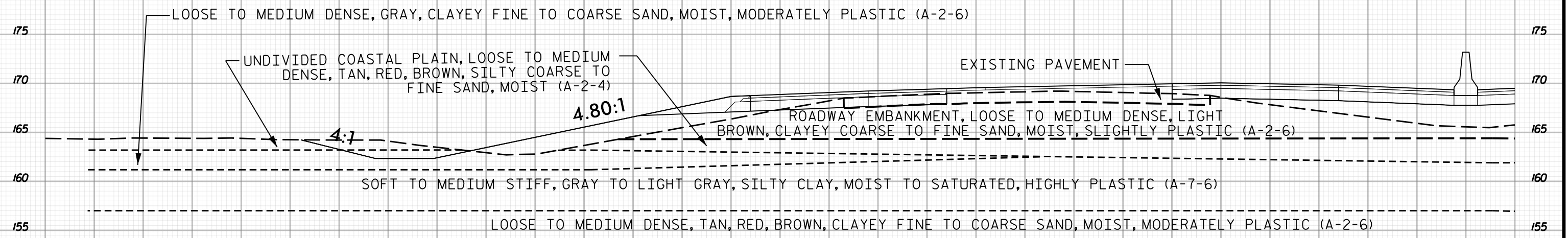

494+50

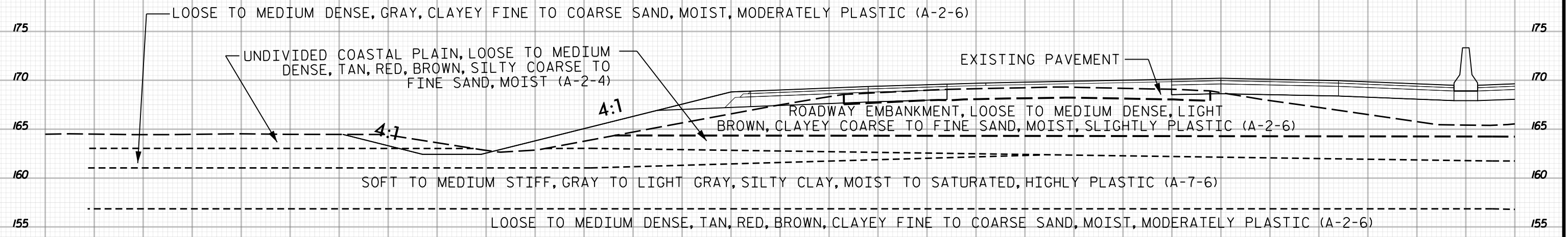

494+00
1 OF 2

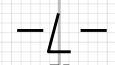

140 135 130 125 120 115 110 105 100 95 90 85 80 75 70 65 60 55 50 45 40 35 30 25 20 15 10 5 0 5

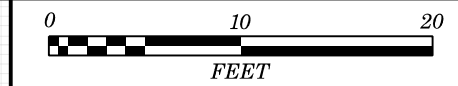

5 0 5 10 15 20 25 30 35 40 45 50 55 60 65 70 75 80 85 90 95 100 105 110 115 120 125 130 135 140 145

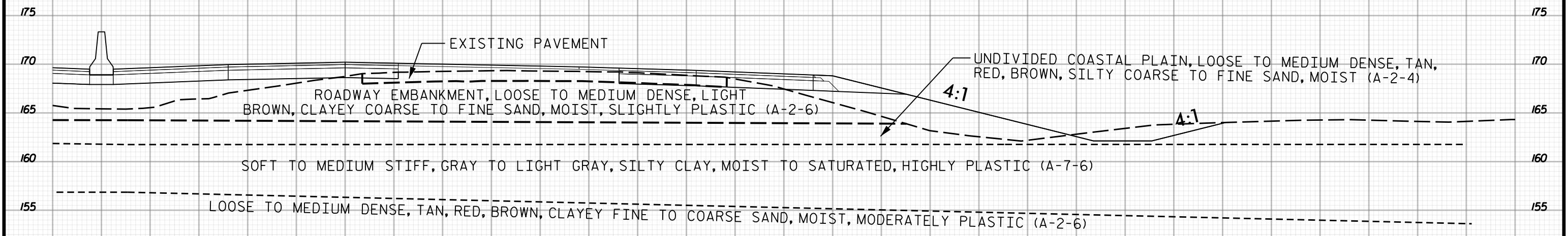
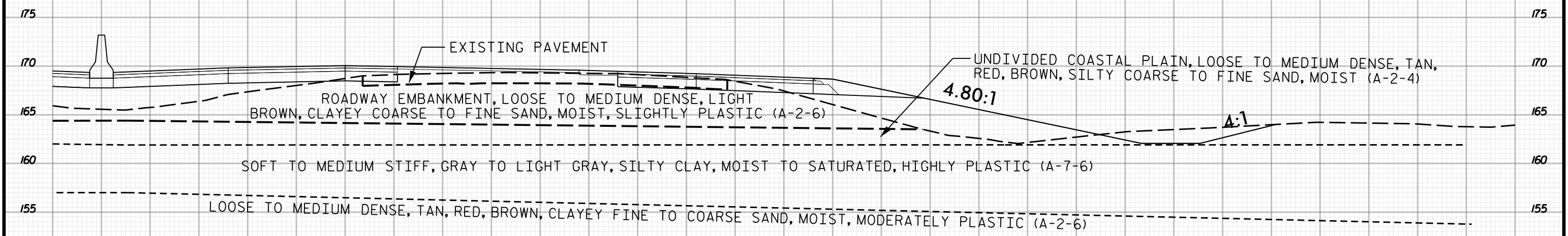

2 OF 2

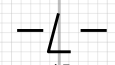

5 0 5 10 15 20 25 30 35 40 45 50 55 60 65 70 75 80 85 90 95 100 105 110 115 120 125 130 135 140 145



140 135 130 125 120 115 110 105 100 95 90 85 80 75 70 65 60 55 50 45 40 35 30 25 20 15 10 5 0 5

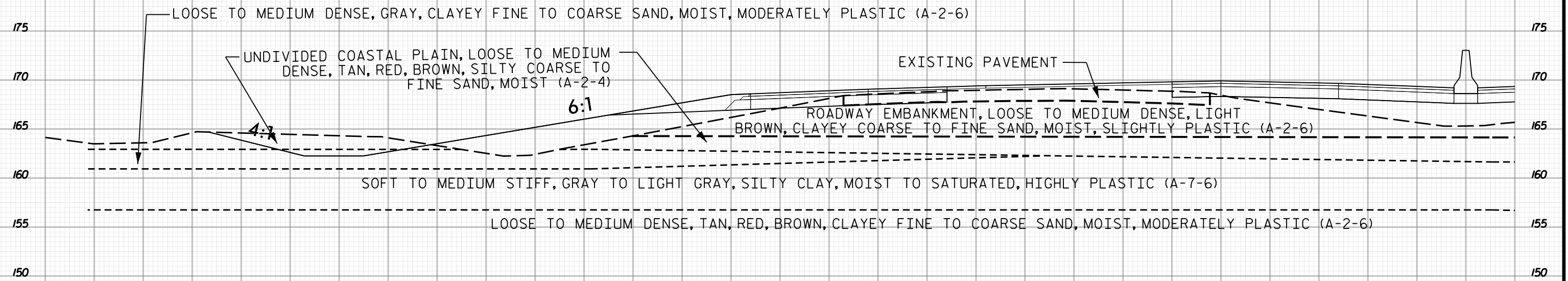

495+00
1 OF 2

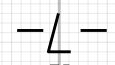

140 135 130 125 120 115 110 105 100 95 90 85 80 75 70 65 60 55 50 45 40 35 30 25 20 15 10 5 0 5

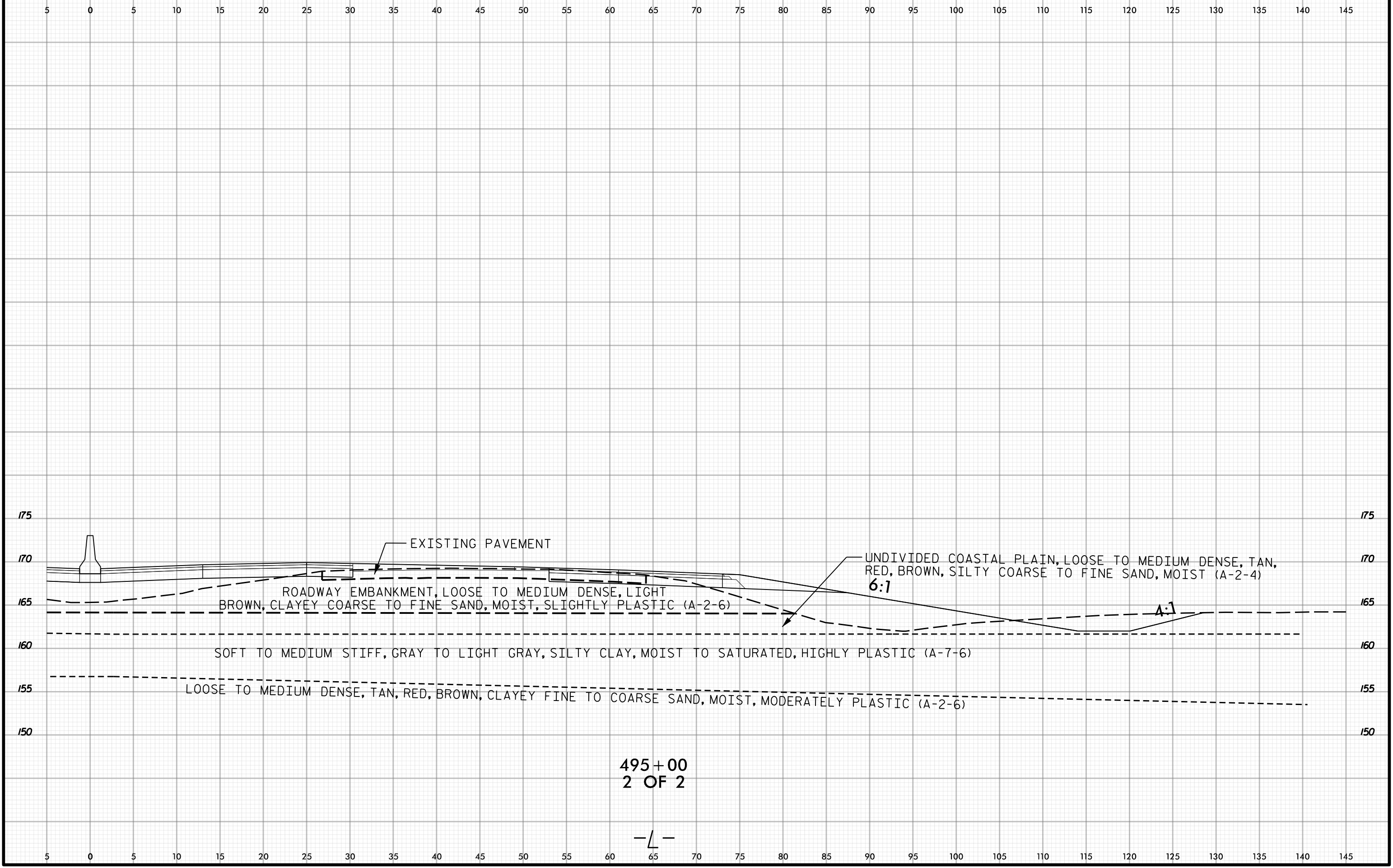

495+00
2 OF 2

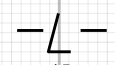

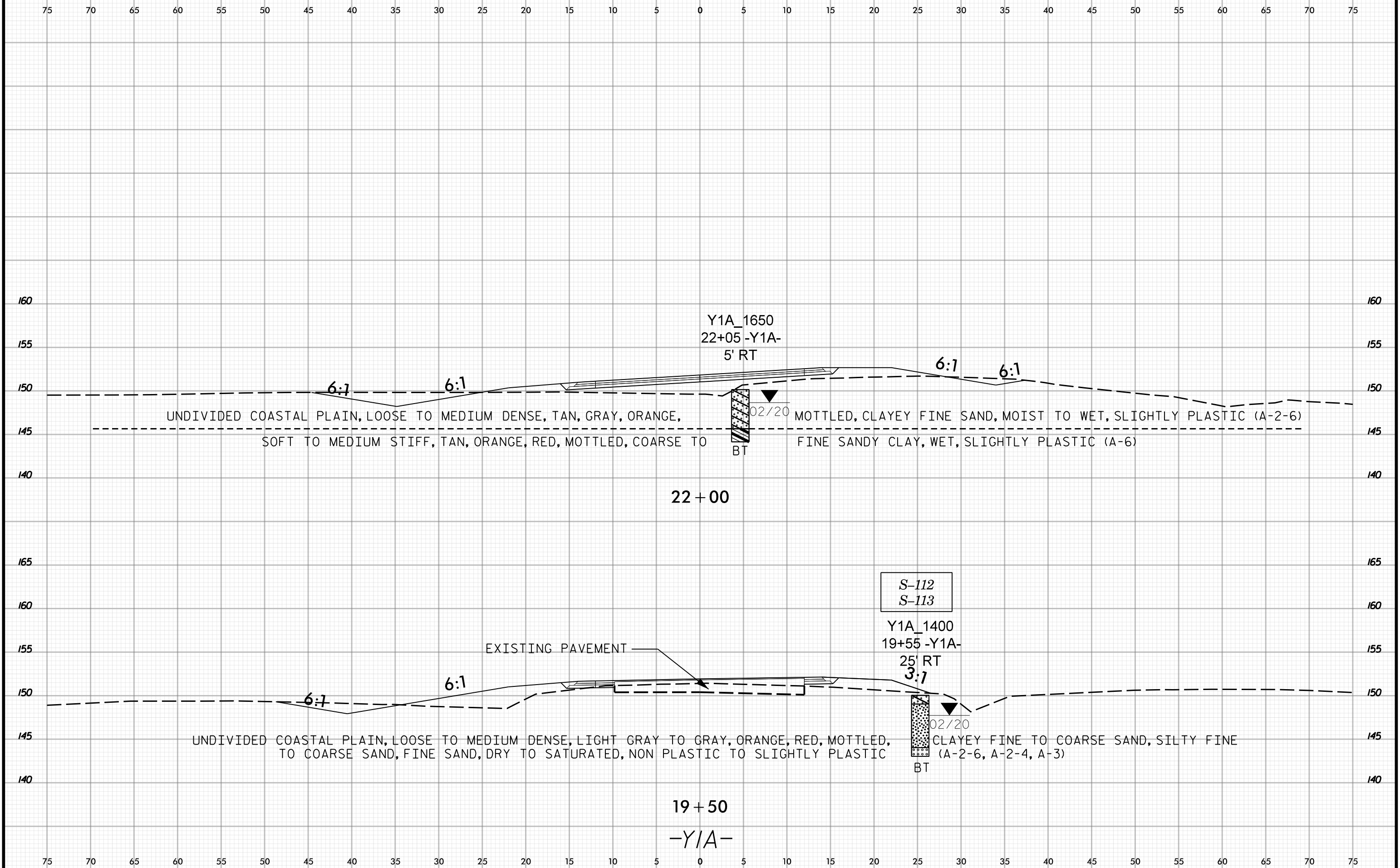

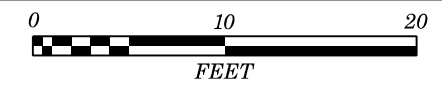

75 70 65 60 55 50 45 40 35 30 25 20 15 10 5 0 5 10 15 20 25 30 35 40 45 50 55 60 65 70 75

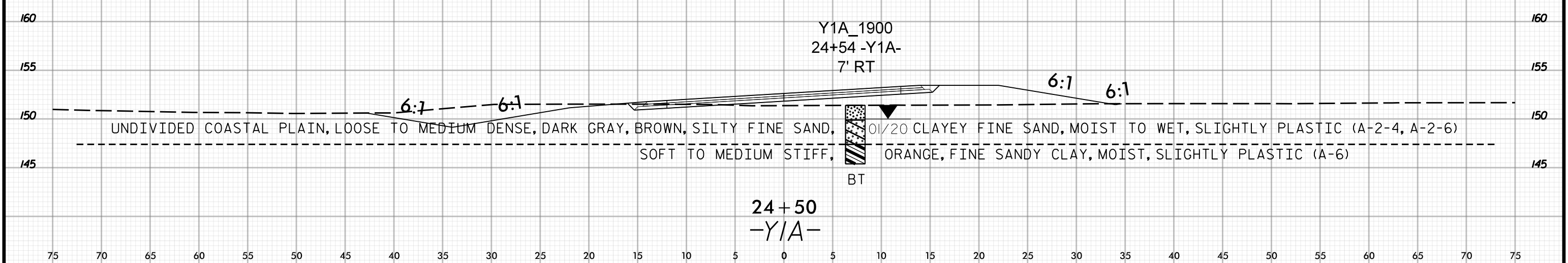
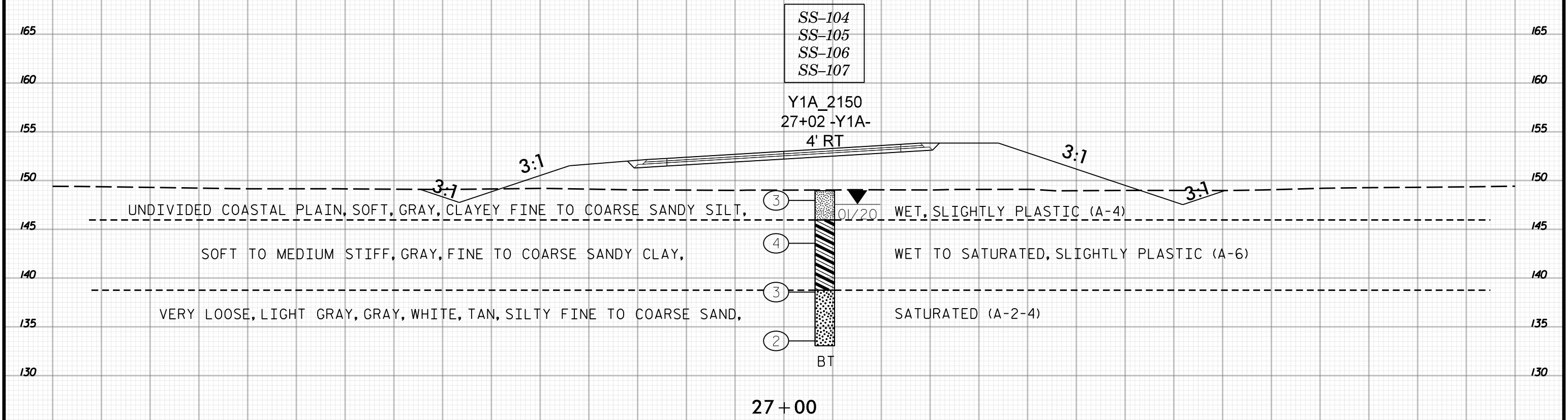

75 70 65 60 55 50 45 40 35 30 25 20 15 10 5 0 5 10 15 20 25 30 35 40 45 50 55 60 65 70 75

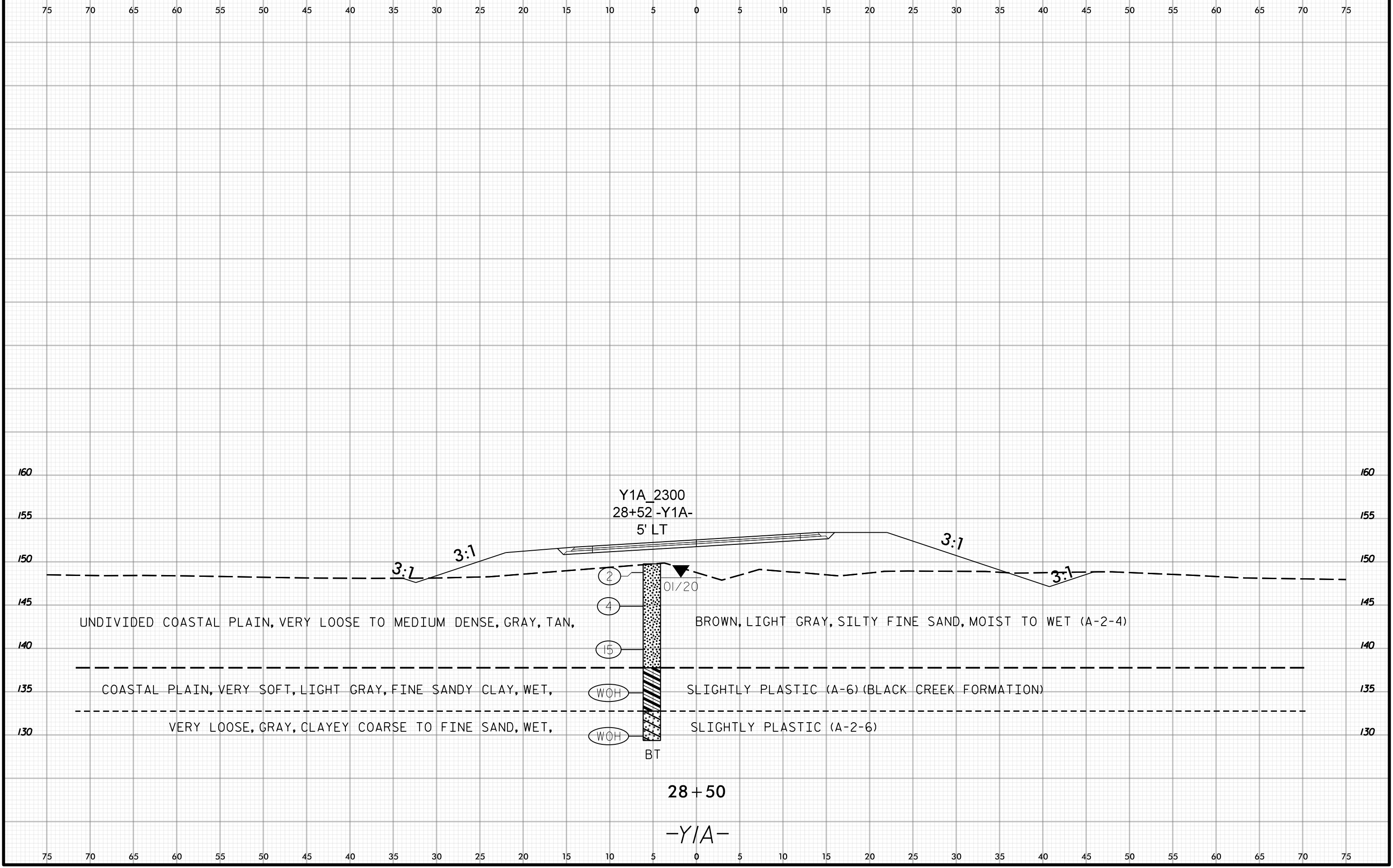
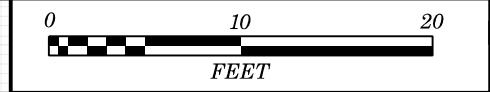

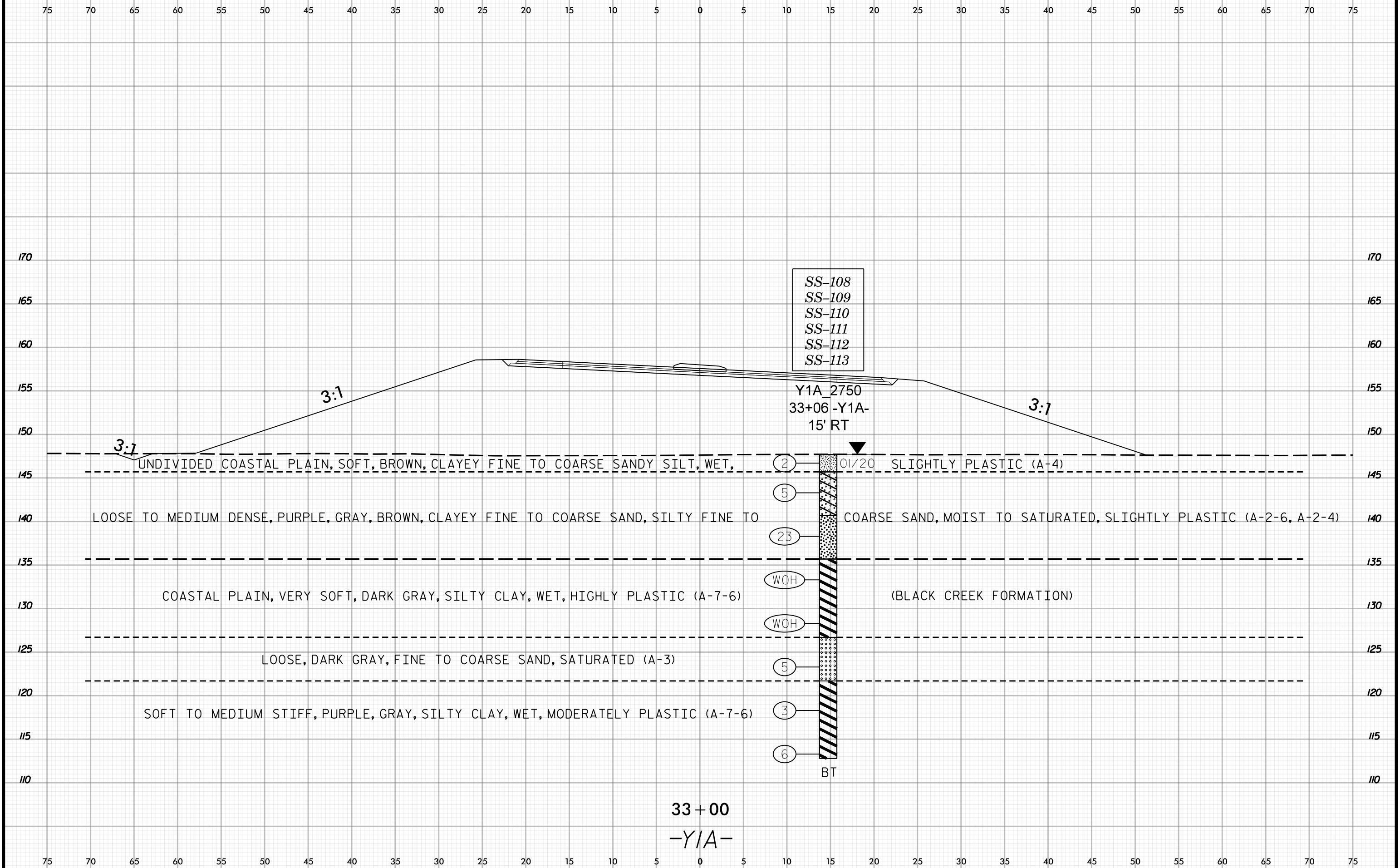
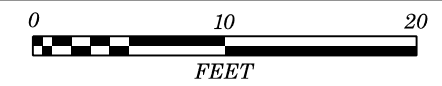

SS-108
SS-109
SS-110
SS-111
SS-112
SS-113

Y1A 2750
33+06 -Y1A-
15' RT

33 + 00
-Y1A-

BT

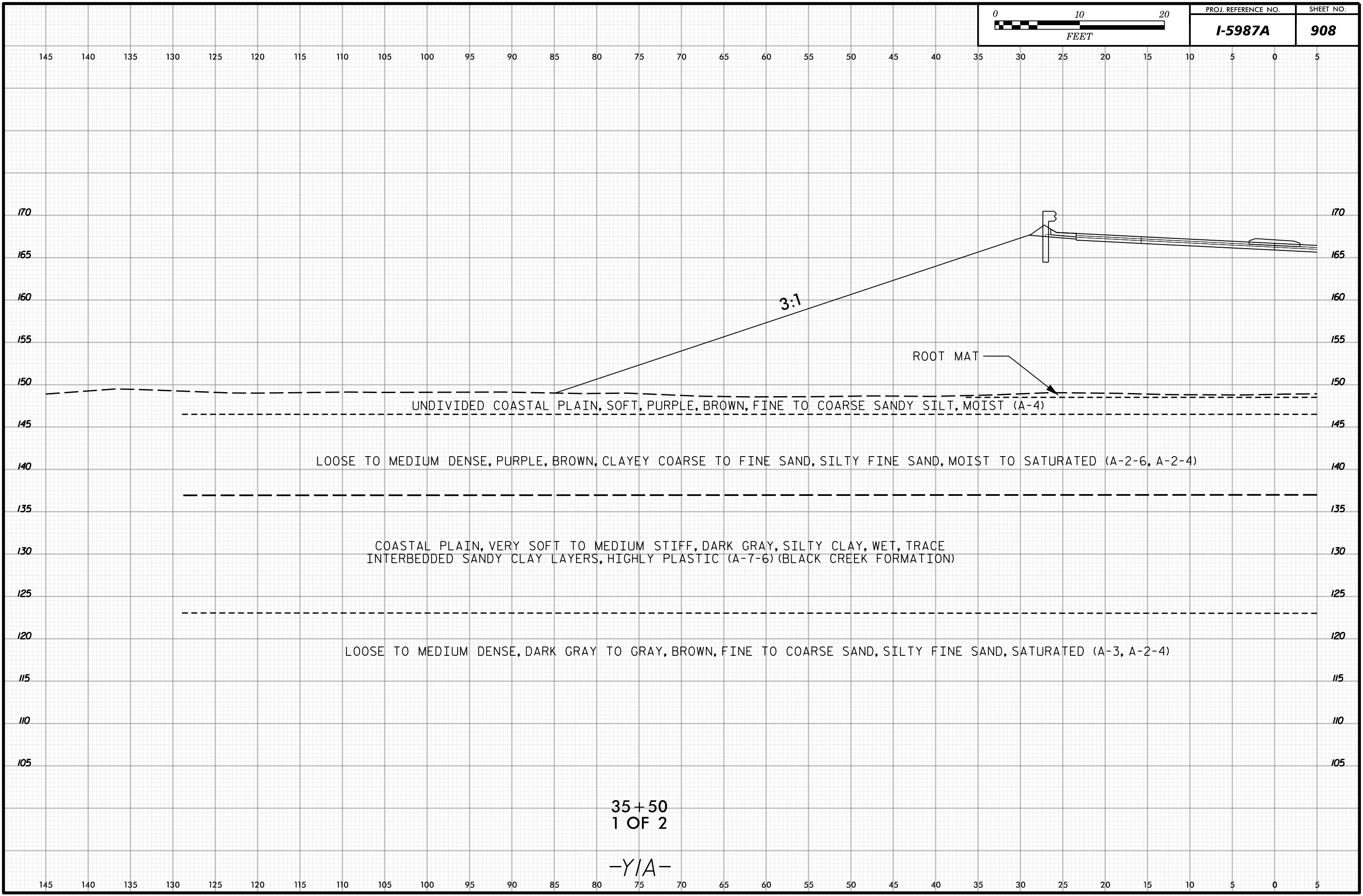

UNDIVIDED COASTAL PLAIN, SOFT, PURPLE, BROWN, FINE TO COARSE SANDY SILT, MOIST (A-4)

LOOSE TO MEDIUM DENSE, PURPLE, BROWN, CLAYEY COARSE TO FINE SAND, SILTY FINE SAND, MOIST TO SATURATED (A-2-6, A-2-4)

COASTAL PLAIN, VERY SOFT TO MEDIUM STIFF, DARK GRAY, SILTY CLAY, WET, TRACE INTERBEDDED SANDY CLAY LAYERS, HIGHLY PLASTIC (A-7-6) (BLACK CREEK FORMATION)

LOOSE TO MEDIUM DENSE, DARK GRAY TO GRAY, BROWN, FINE TO COARSE SAND, SILTY FINE SAND, SATURATED (A-3, A-2-4)

35+50
1 OF 2

-Y/A-

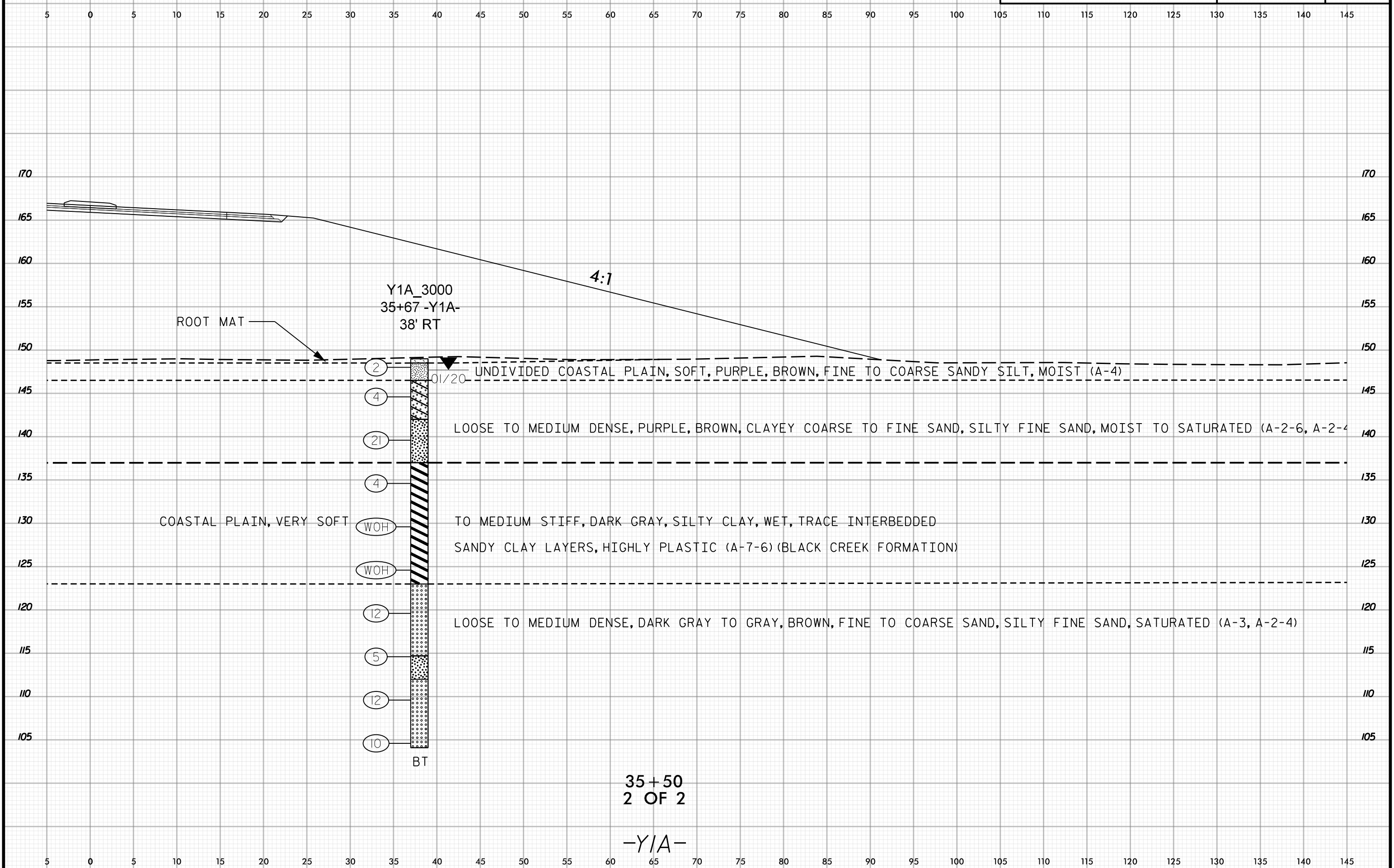

35+50
2 OF 2

-Y/A-

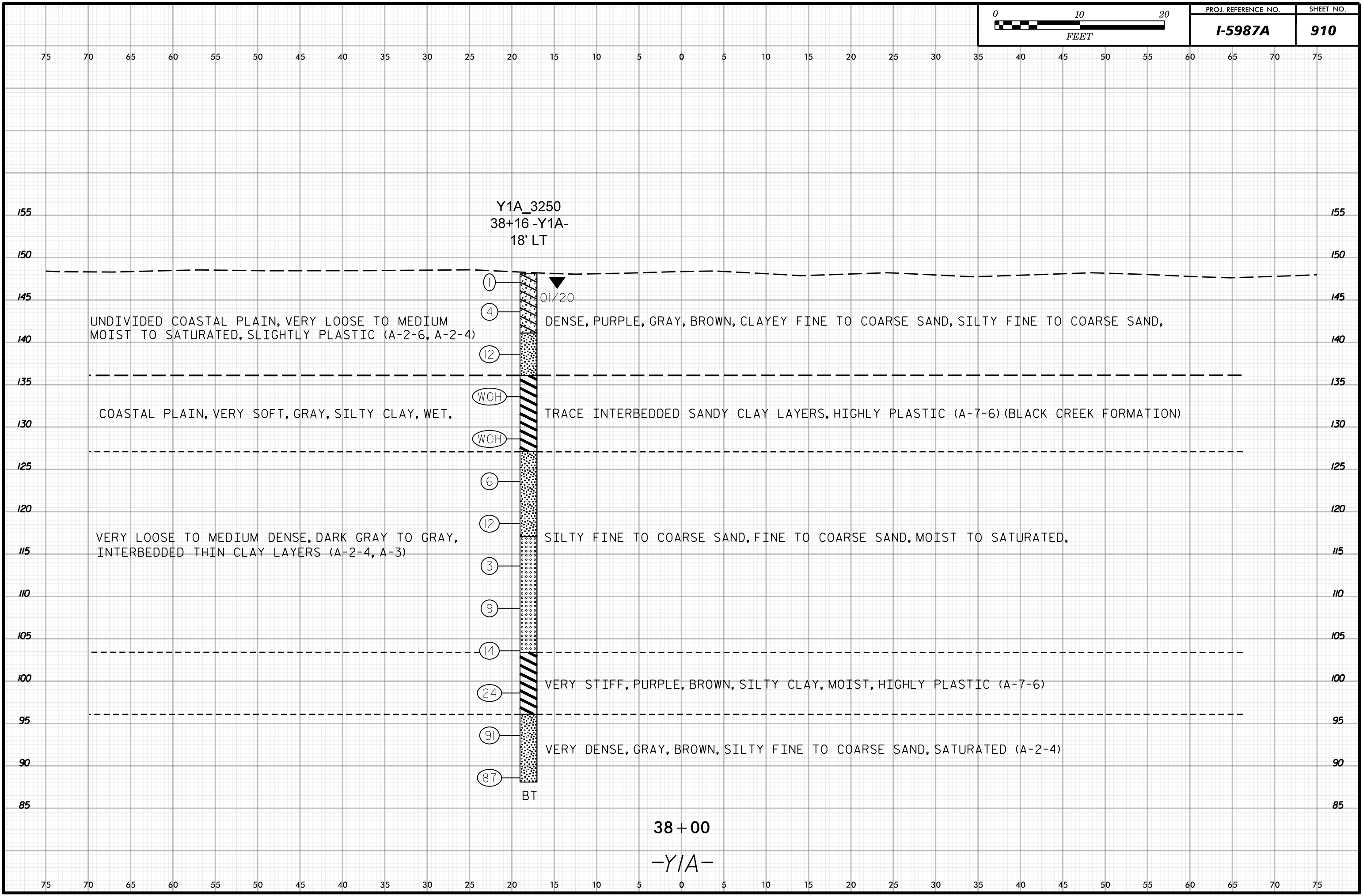

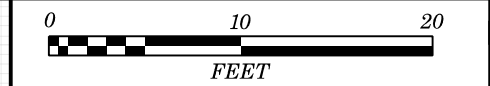

145 140 135 130 125 120 115 110 105 100 95 90 85 80 75 70 65 60 55 50 45 40 35 30 25 20 15 10 5 0 5

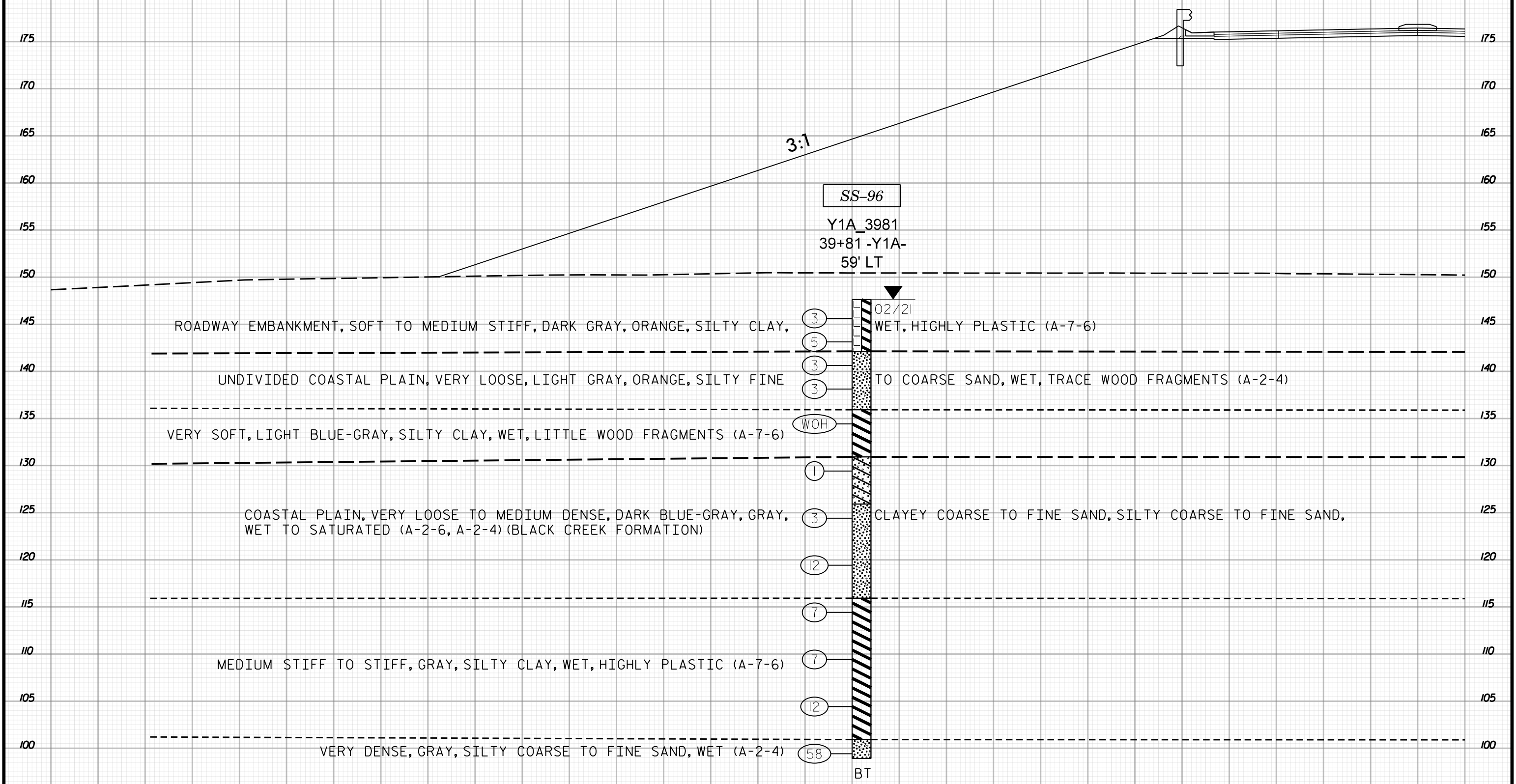

145 140 135 130 125 120 115 110 105 100 95 90 85 80 75 70 65 60 55 50 45 40 35 30 25 20 15 10 5 0 5

40+00
1 OF 2
-Y1A-

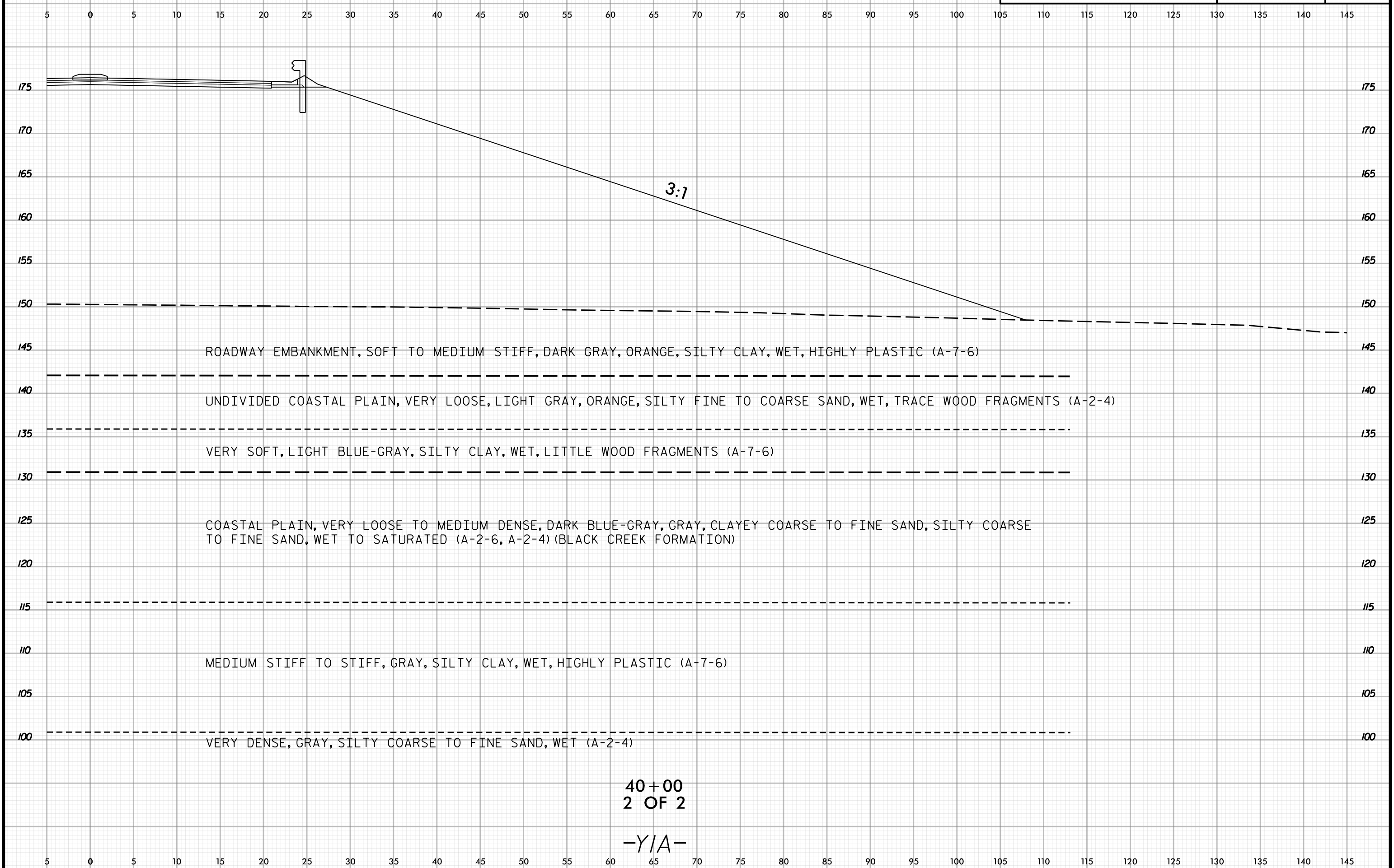

ROADWAY EMBANKMENT, SOFT TO MEDIUM STIFF, DARK GRAY, ORANGE, SILTY CLAY, WET, HIGHLY PLASTIC (A-7-6)

UNDIVIDED COASTAL PLAIN, VERY LOOSE, LIGHT GRAY, ORANGE, SILTY FINE TO COARSE SAND, WET, TRACE WOOD FRAGMENTS (A-2-4)

VERY SOFT, LIGHT BLUE-GRAY, SILTY CLAY, WET, LITTLE WOOD FRAGMENTS (A-7-6)

COASTAL PLAIN, VERY LOOSE TO MEDIUM DENSE, DARK BLUE-GRAY, GRAY, CLAYEY COARSE TO FINE SAND, SILTY COARSE TO FINE SAND, WET TO SATURATED (A-2-6, A-2-4) (BLACK CREEK FORMATION)

MEDIUM STIFF TO STIFF, GRAY, SILTY CLAY, WET, HIGHLY PLASTIC (A-7-6)

VERY DENSE, GRAY, SILTY COARSE TO FINE SAND, WET (A-2-4)

40+00
2 OF 2

-Y/A-

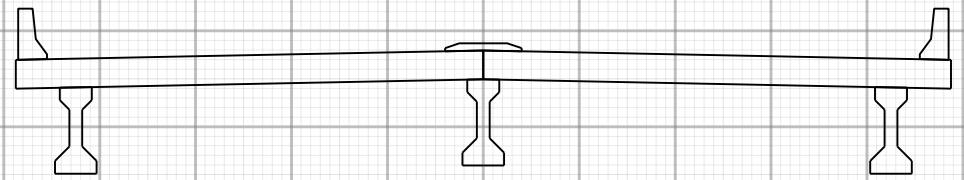
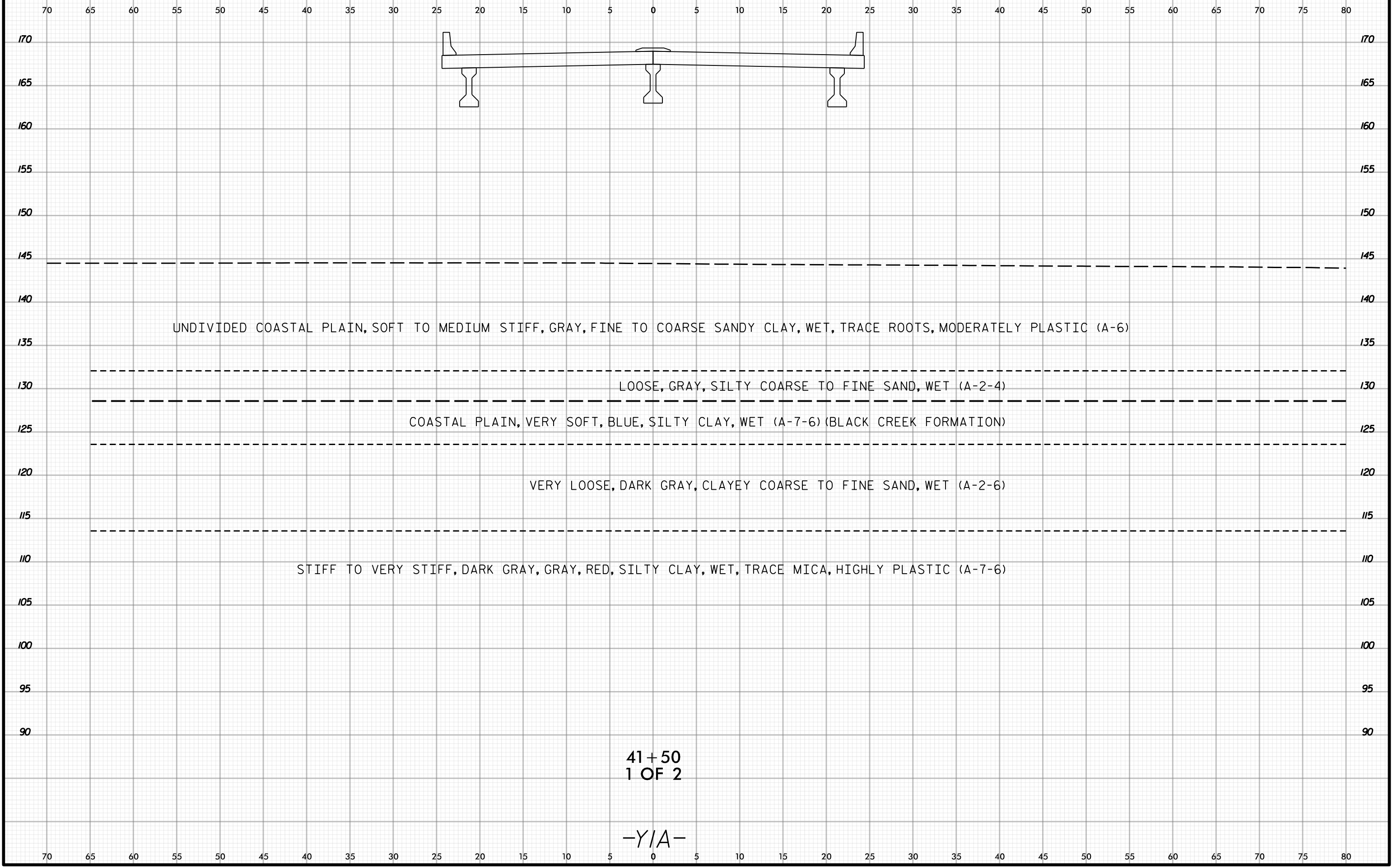
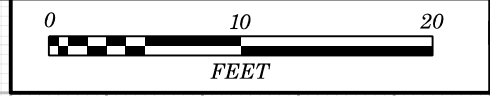

UNDIVIDED COASTAL PLAIN, SOFT TO MEDIUM STIFF, GRAY, FINE TO COARSE SANDY CLAY, WET, TRACE ROOTS, MODERATELY PLASTIC (A-6)

LOOSE, GRAY, SILTY COARSE TO FINE SAND, WET (A-2-4)

COASTAL PLAIN, VERY SOFT, BLUE, SILTY CLAY, WET (A-7-6) (BLACK CREEK FORMATION)

VERY LOOSE, DARK GRAY, CLAYEY COARSE TO FINE SAND, WET (A-2-6)

STIFF TO VERY STIFF, DARK GRAY, GRAY, RED, SILTY CLAY, WET, TRACE MICA, HIGHLY PLASTIC (A-7-6)

41 + 50
1 OF 2

-Y/A-

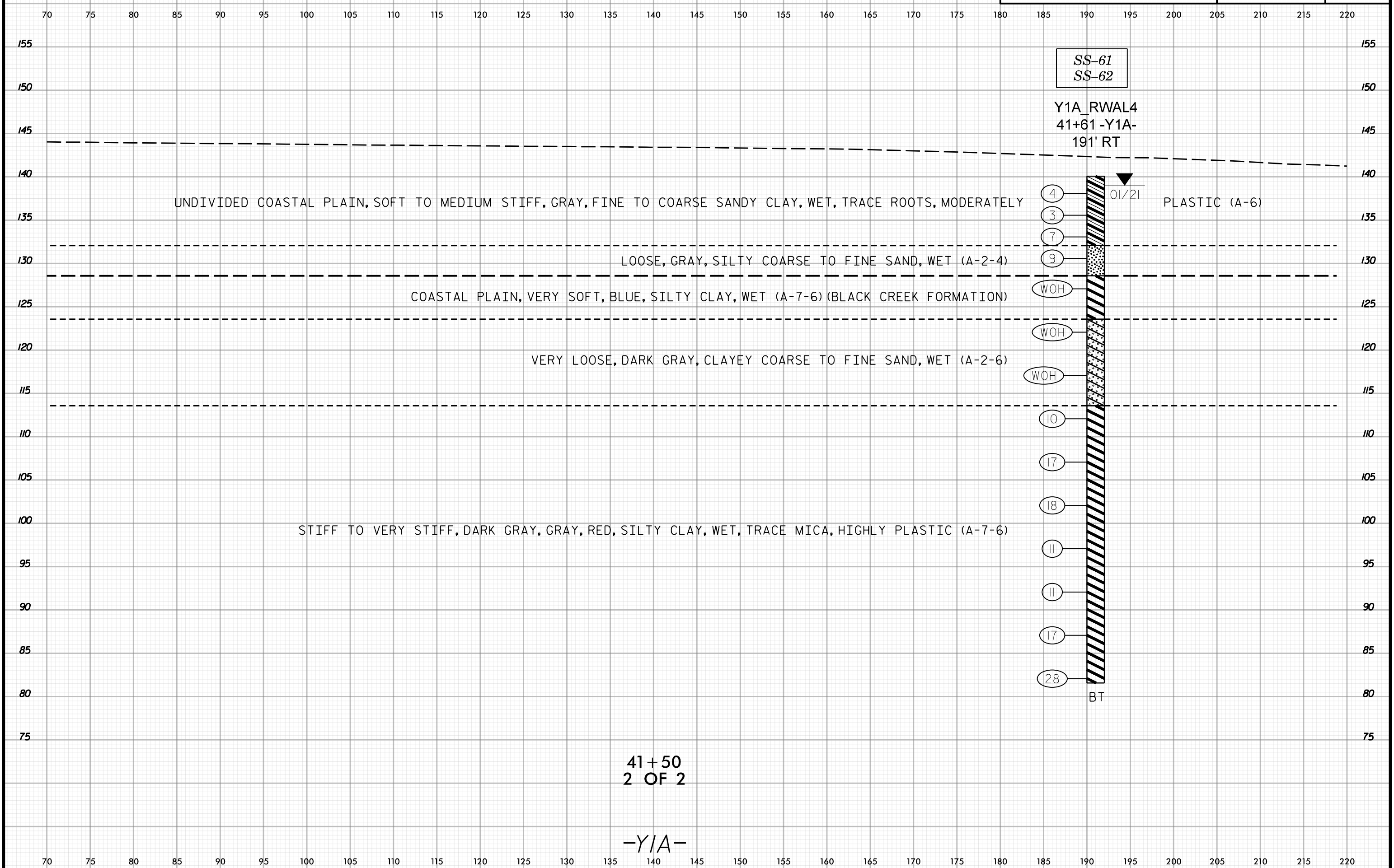
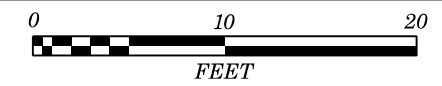

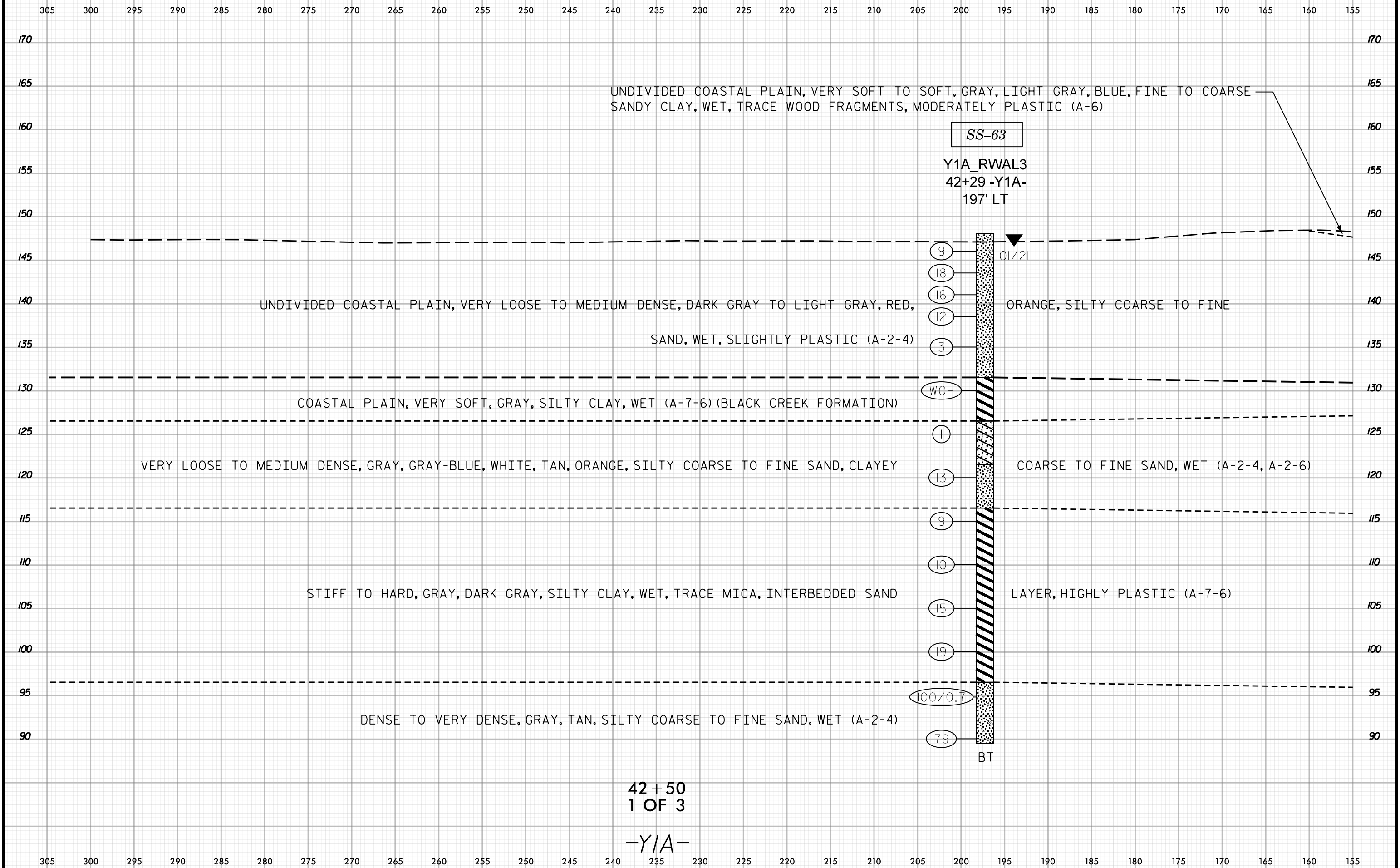

UNDIVIDED COASTAL PLAIN, VERY SOFT TO SOFT, GRAY, LIGHT GRAY, BLUE, FINE TO COARSE SANDY CLAY, WET, TRACE WOOD FRAGMENTS, MODERATELY PLASTIC (A-6)

SS-63
 Y1A_RWAL3
 42+29 -Y1A-
 197' LT

- 9
- 18
- 16
- 12
- 3
- WOH
- 1
- 13
- 9
- 10
- 15
- 19
- 100/0.7
- 79

01/21

ORANGE, SILTY COARSE TO FINE

COARSE TO FINE SAND, WET (A-2-4, A-2-6)

LAYER, HIGHLY PLASTIC (A-7-6)

BT

UNDIVIDED COASTAL PLAIN, VERY LOOSE TO MEDIUM DENSE, DARK GRAY TO LIGHT GRAY, RED, SAND, WET, SLIGHTLY PLASTIC (A-2-4)

COASTAL PLAIN, VERY SOFT, GRAY, SILTY CLAY, WET (A-7-6) (BLACK CREEK FORMATION)

VERY LOOSE TO MEDIUM DENSE, GRAY, GRAY-BLUE, WHITE, TAN, ORANGE, SILTY COARSE TO FINE SAND, CLAYEY

STIFF TO HARD, GRAY, DARK GRAY, SILTY CLAY, WET, TRACE MICA, INTERBEDDED SAND

DENSE TO VERY DENSE, GRAY, TAN, SILTY COARSE TO FINE SAND, WET (A-2-4)

42+50
 1 OF 3
 -Y/A-

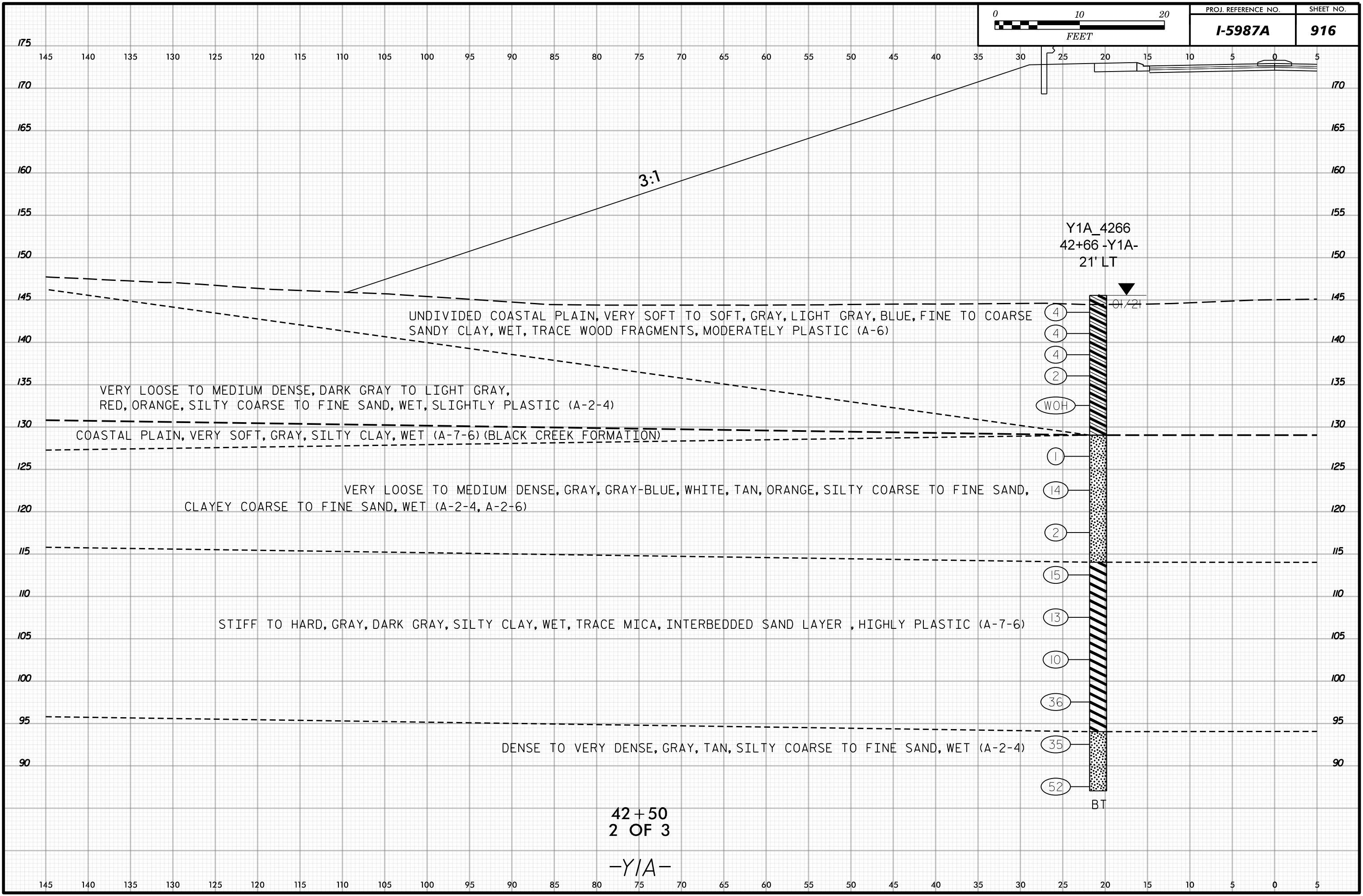
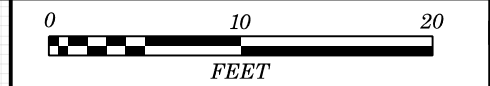

Y1A_4266
42+66 -Y1A-
21' LT

UNDIVIDED COASTAL PLAIN, VERY SOFT TO SOFT, GRAY, LIGHT GRAY, BLUE, FINE TO COARSE SANDY CLAY, WET, TRACE WOOD FRAGMENTS, MODERATELY PLASTIC (A-6)

VERY LOOSE TO MEDIUM DENSE, DARK GRAY TO LIGHT GRAY, RED, ORANGE, SILTY COARSE TO FINE SAND, WET, SLIGHTLY PLASTIC (A-2-4)

COASTAL PLAIN, VERY SOFT, GRAY, SILTY CLAY, WET (A-7-6) (BLACK CREEK FORMATION)

VERY LOOSE TO MEDIUM DENSE, GRAY, GRAY-BLUE, WHITE, TAN, ORANGE, SILTY COARSE TO FINE SAND, CLAYEY COARSE TO FINE SAND, WET (A-2-4, A-2-6)

STIFF TO HARD, GRAY, DARK GRAY, SILTY CLAY, WET, TRACE MICA, INTERBEDDED SAND LAYER, HIGHLY PLASTIC (A-7-6)

DENSE TO VERY DENSE, GRAY, TAN, SILTY COARSE TO FINE SAND, WET (A-2-4)

42+50
2 OF 3

-Y/A-

01/21

BT

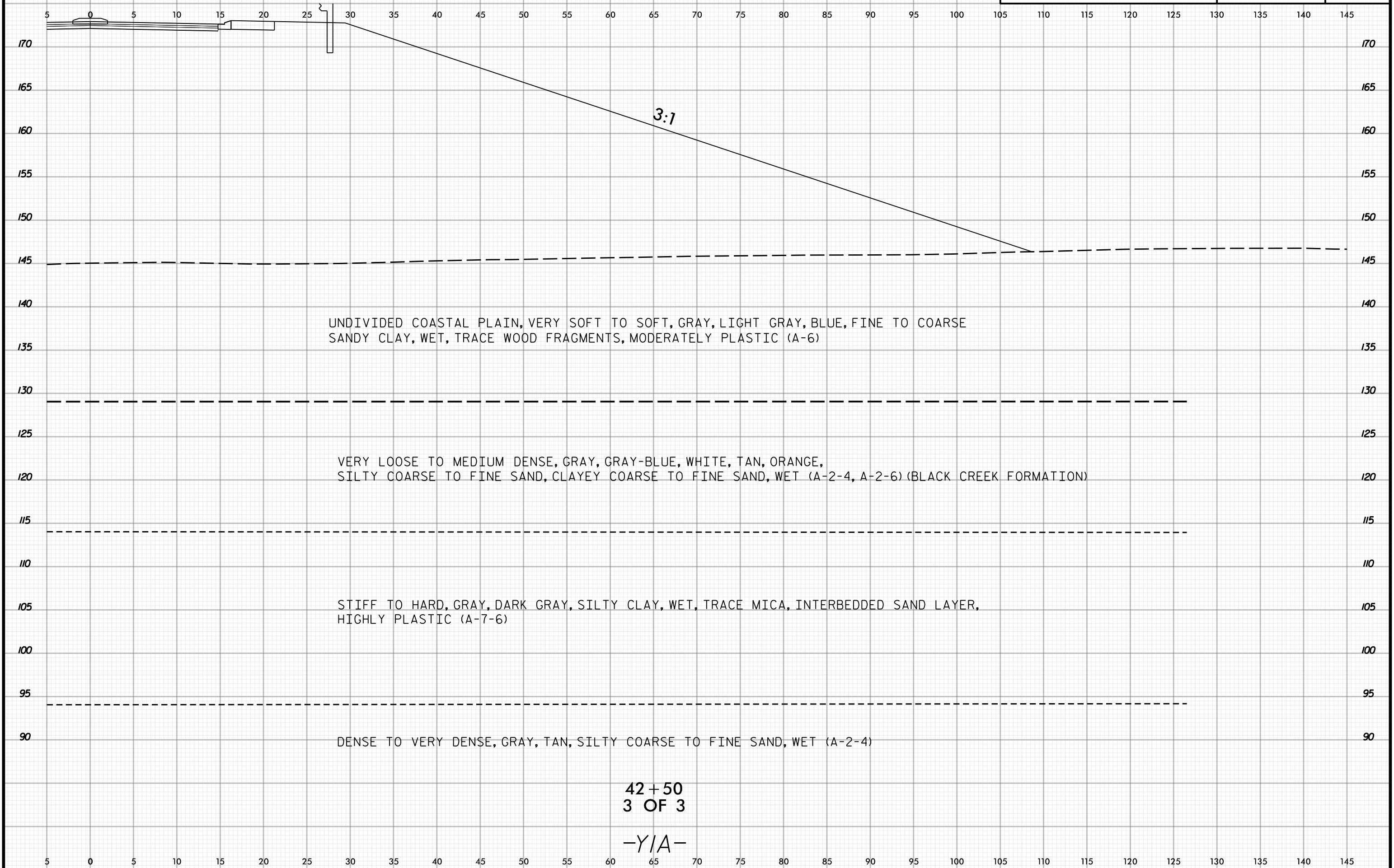

UNDIVIDED COASTAL PLAIN, VERY SOFT TO SOFT, GRAY, LIGHT GRAY, BLUE, FINE TO COARSE SANDY CLAY, WET, TRACE WOOD FRAGMENTS, MODERATELY PLASTIC (A-6)

VERY LOOSE TO MEDIUM DENSE, GRAY, GRAY-BLUE, WHITE, TAN, ORANGE, SILTY COARSE TO FINE SAND, CLAYEY COARSE TO FINE SAND, WET (A-2-4, A-2-6) (BLACK CREEK FORMATION)

STIFF TO HARD, GRAY, DARK GRAY, SILTY CLAY, WET, TRACE MICA, INTERBEDDED SAND LAYER, HIGHLY PLASTIC (A-7-6)

DENSE TO VERY DENSE, GRAY, TAN, SILTY COARSE TO FINE SAND, WET (A-2-4)

42+50
3 OF 3
-Y/A-

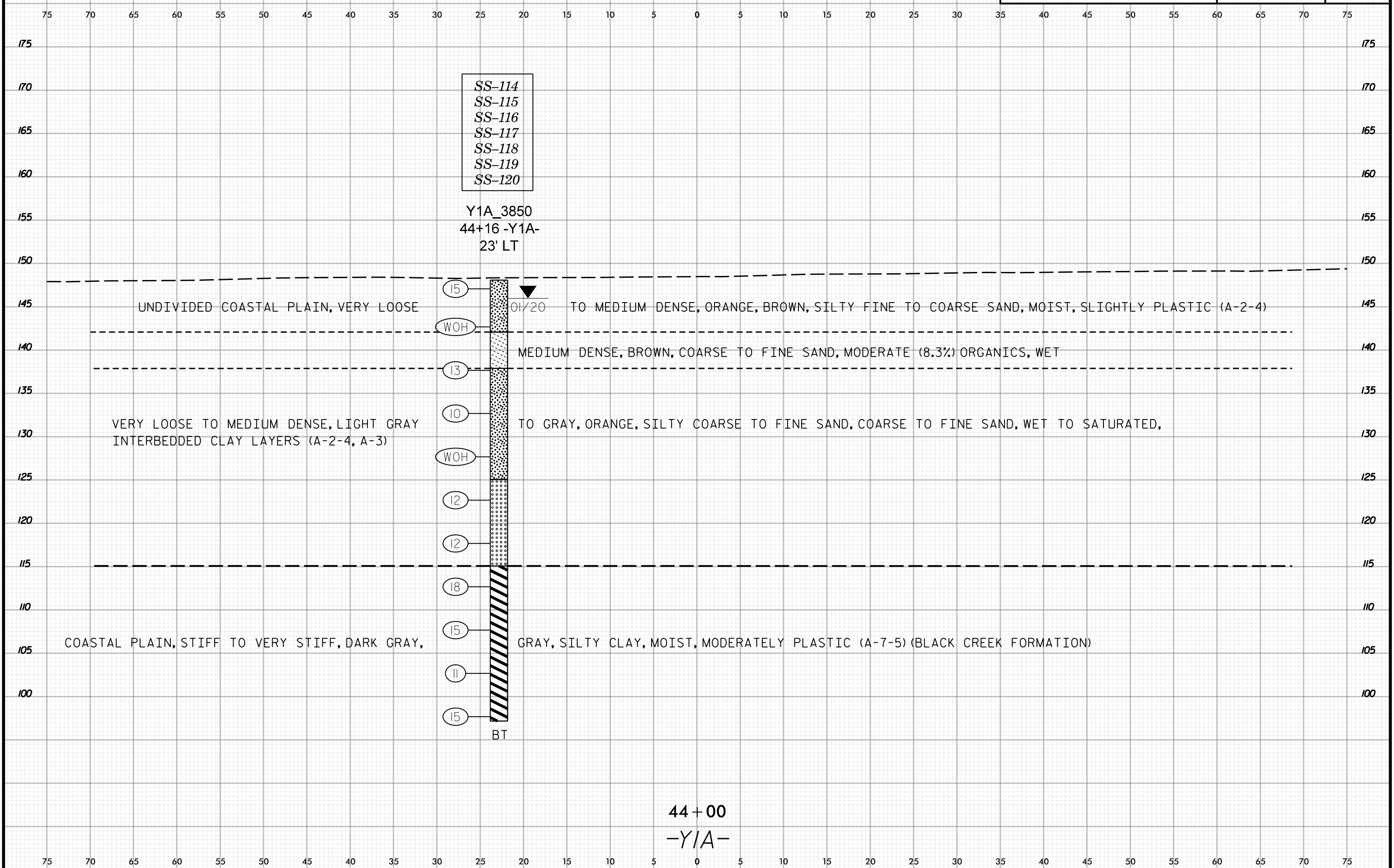

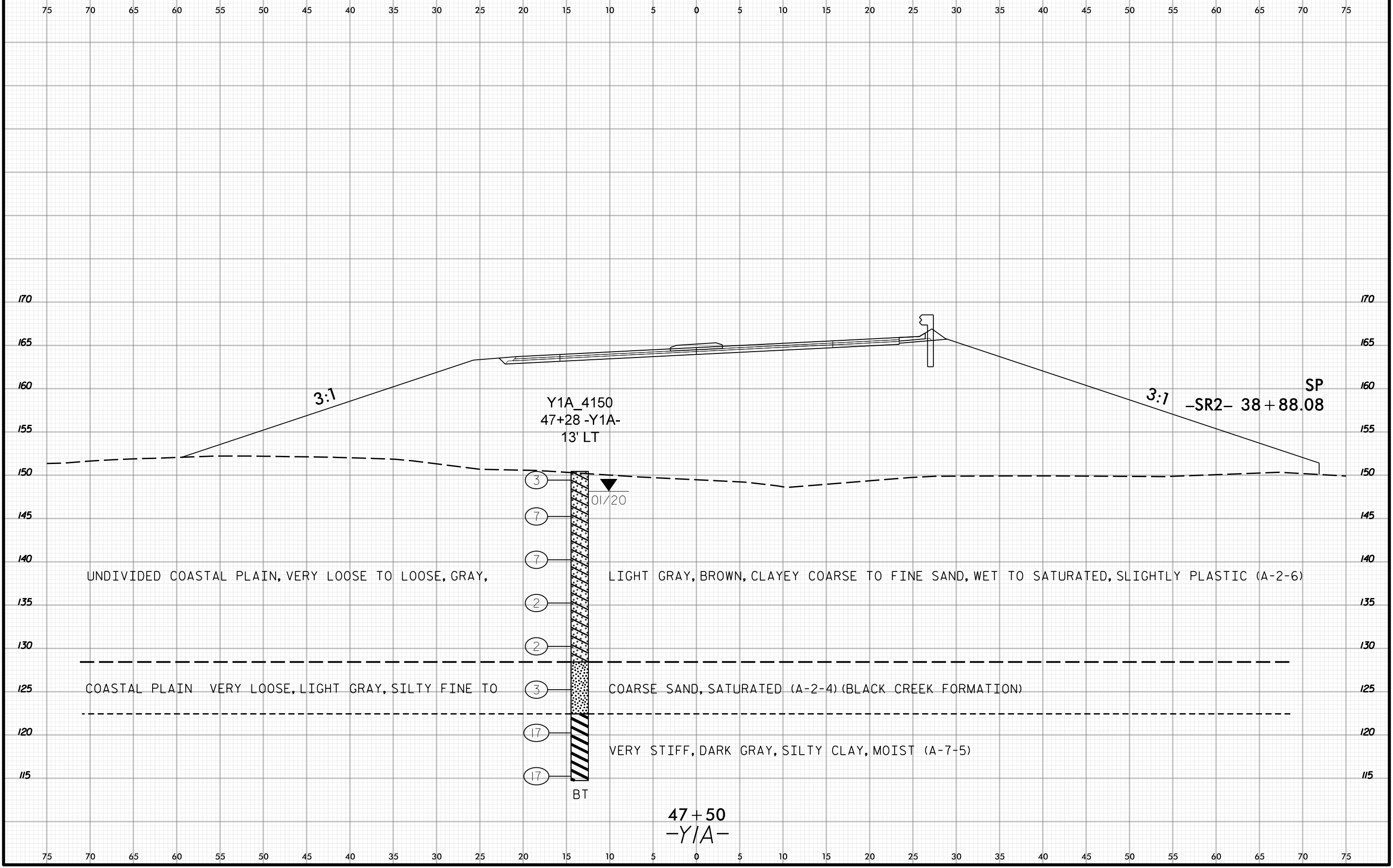
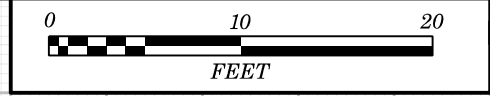

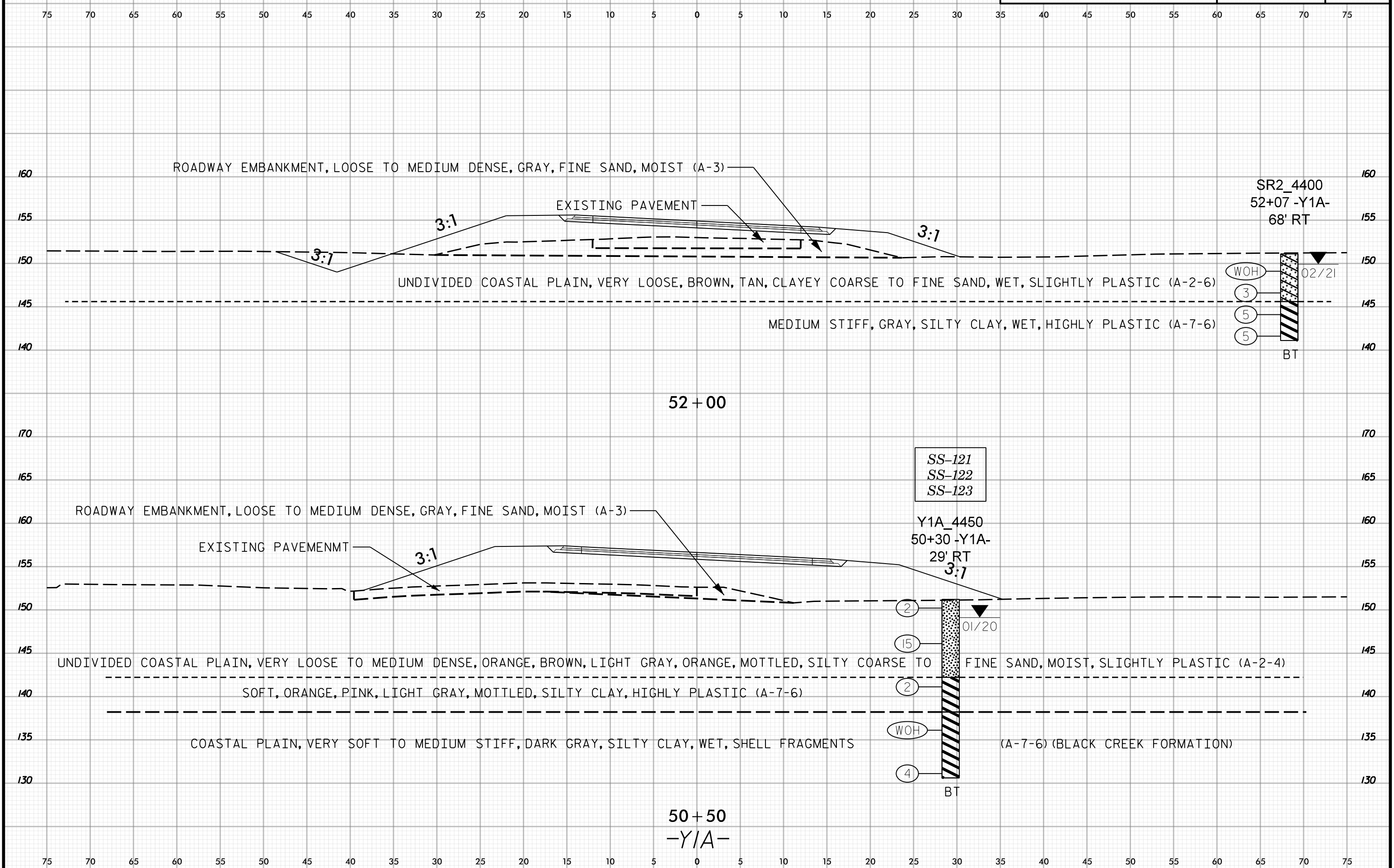
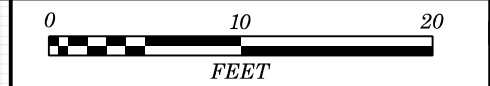



75 70 65 60 55 50 45 40 35 30 25 20 15 10 5 0 5 10 15 20 25 30 35 40 45 50 55 60 65 70 75

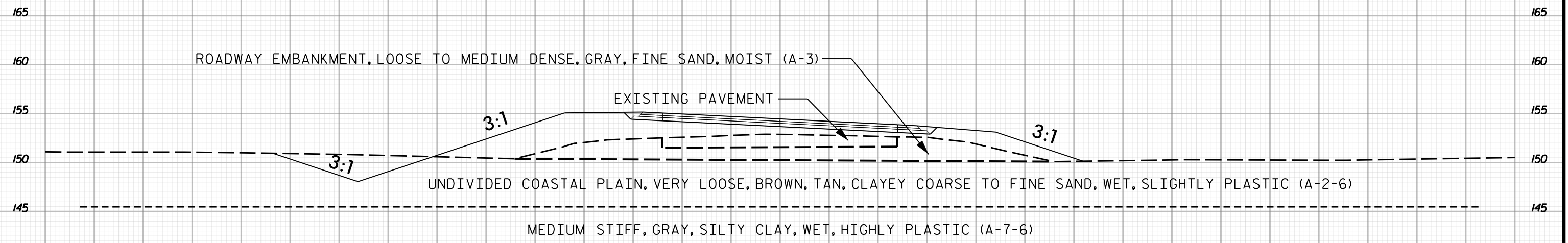
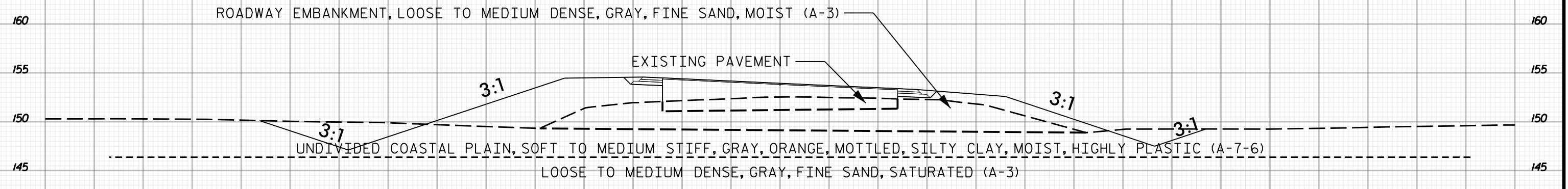

75 70 65 60 55 50 45 40 35 30 25 20 15 10 5 0 5 10 15 20 25 30 35 40 45 50 55 60 65 70 75

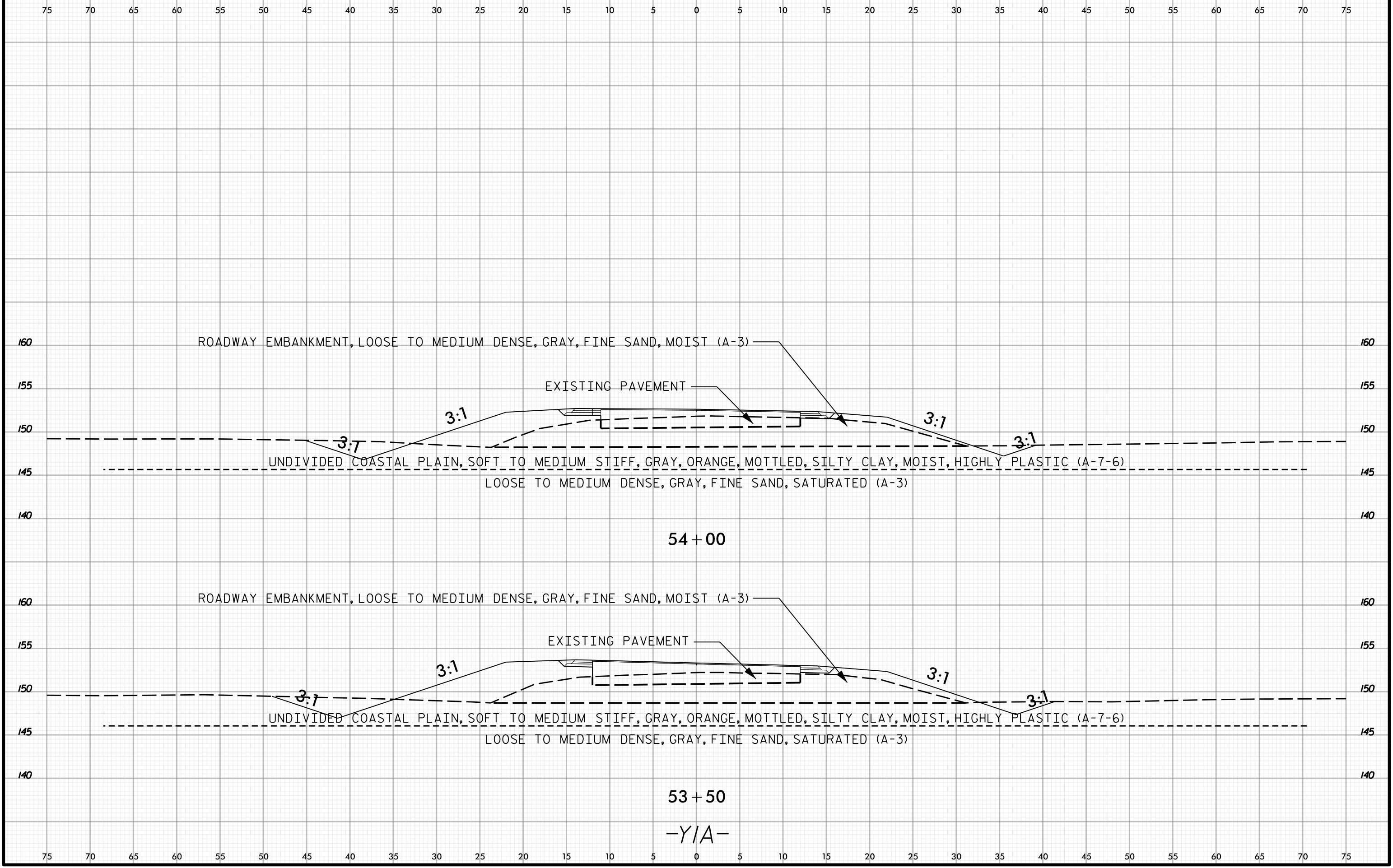

ROADWAY EMBANKMENT, LOOSE TO MEDIUM DENSE, GRAY, FINE SAND, MOIST (A-3)

EXISTING PAVEMENT

UNDIVIDED COASTAL PLAIN, SOFT TO MEDIUM STIFF, GRAY, ORANGE, MOTTLED, SILTY CLAY, MOIST, HIGHLY PLASTIC (A-7-6)

LOOSE TO MEDIUM DENSE, GRAY, FINE SAND, SATURATED (A-3)

54 + 00

ROADWAY EMBANKMENT, LOOSE TO MEDIUM DENSE, GRAY, FINE SAND, MOIST (A-3)

EXISTING PAVEMENT

UNDIVIDED COASTAL PLAIN, SOFT TO MEDIUM STIFF, GRAY, ORANGE, MOTTLED, SILTY CLAY, MOIST, HIGHLY PLASTIC (A-7-6)

LOOSE TO MEDIUM DENSE, GRAY, FINE SAND, SATURATED (A-3)

53 + 50

-Y/A-

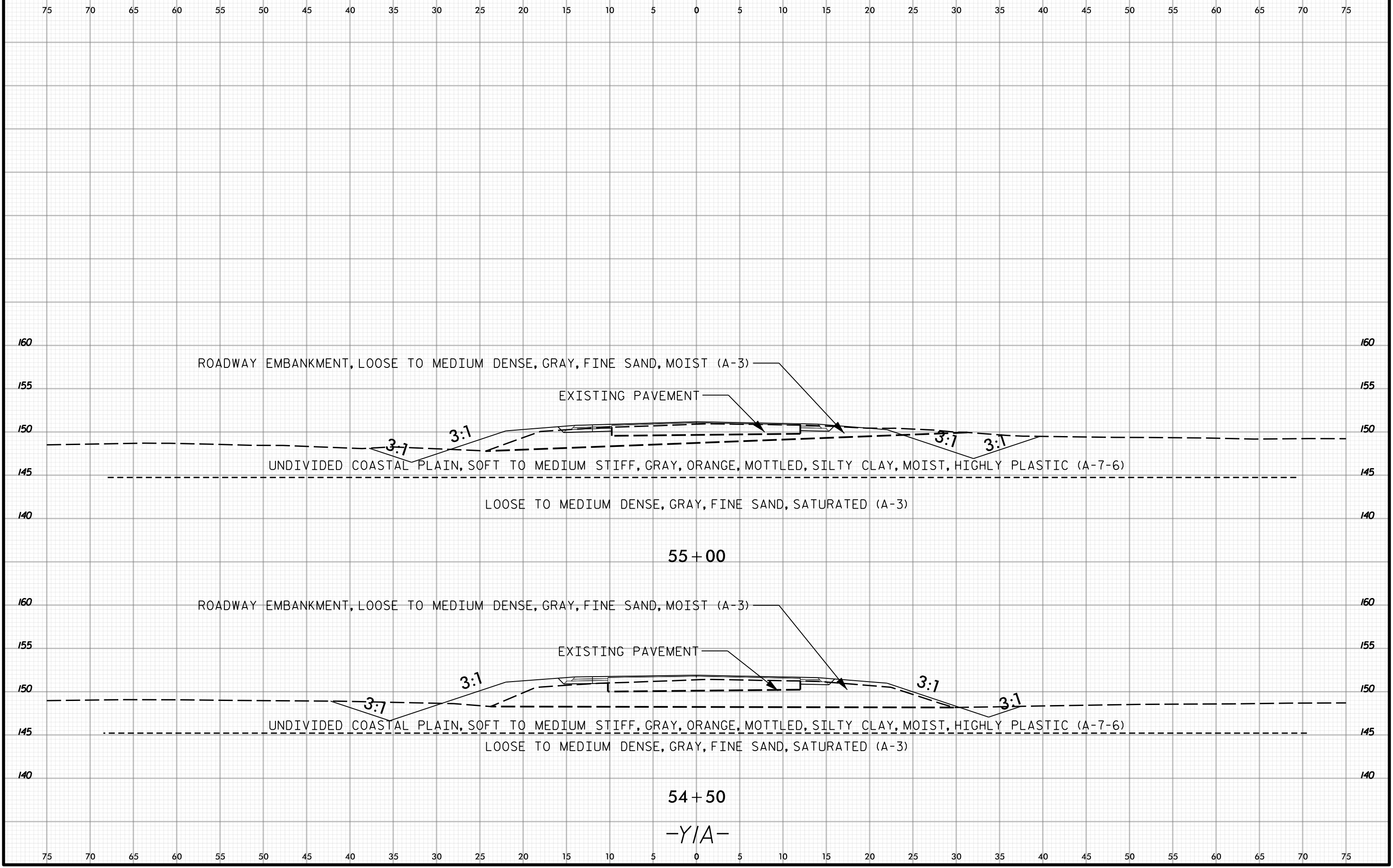

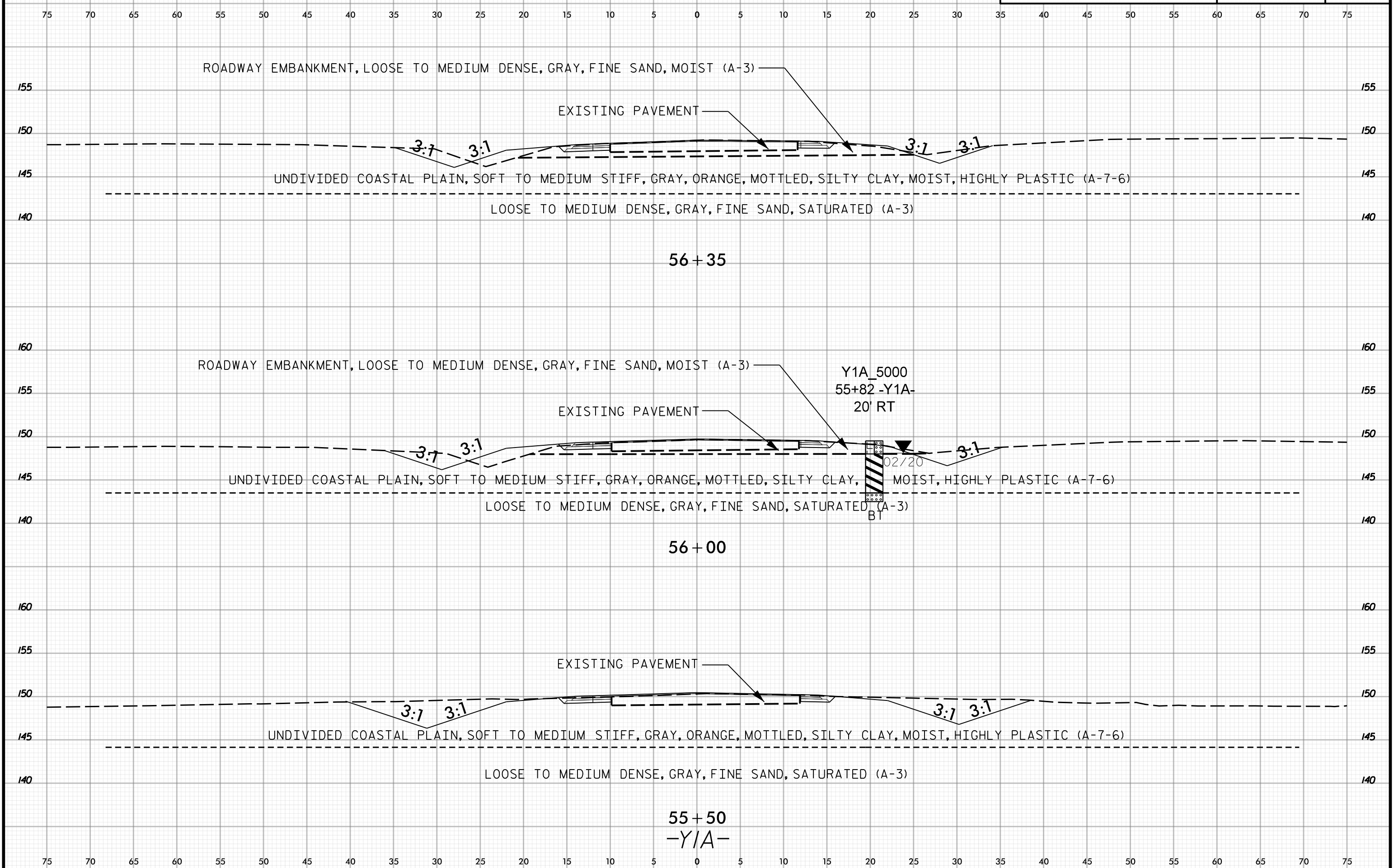

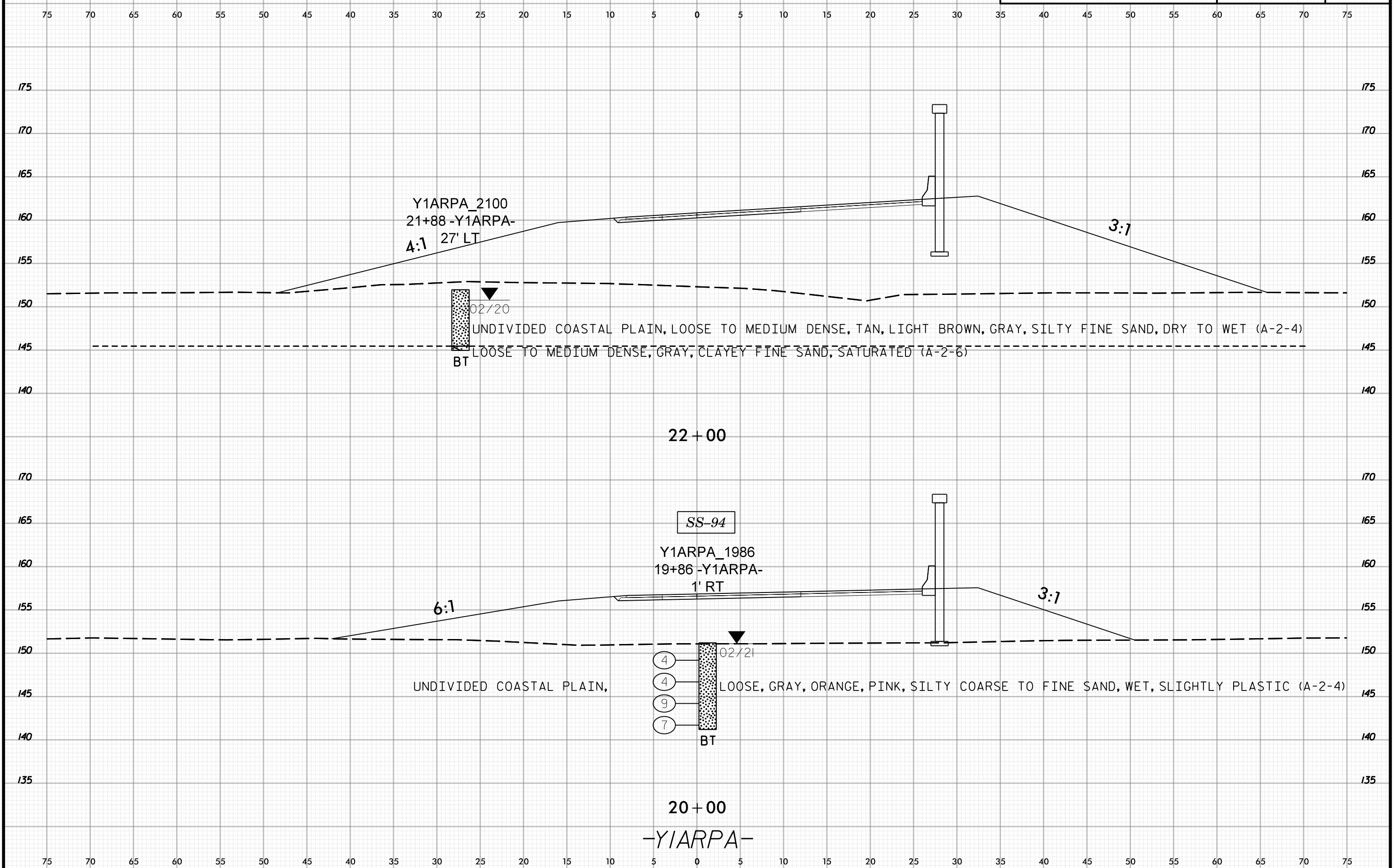
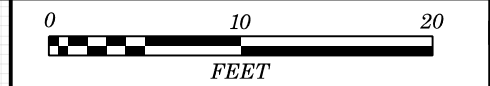

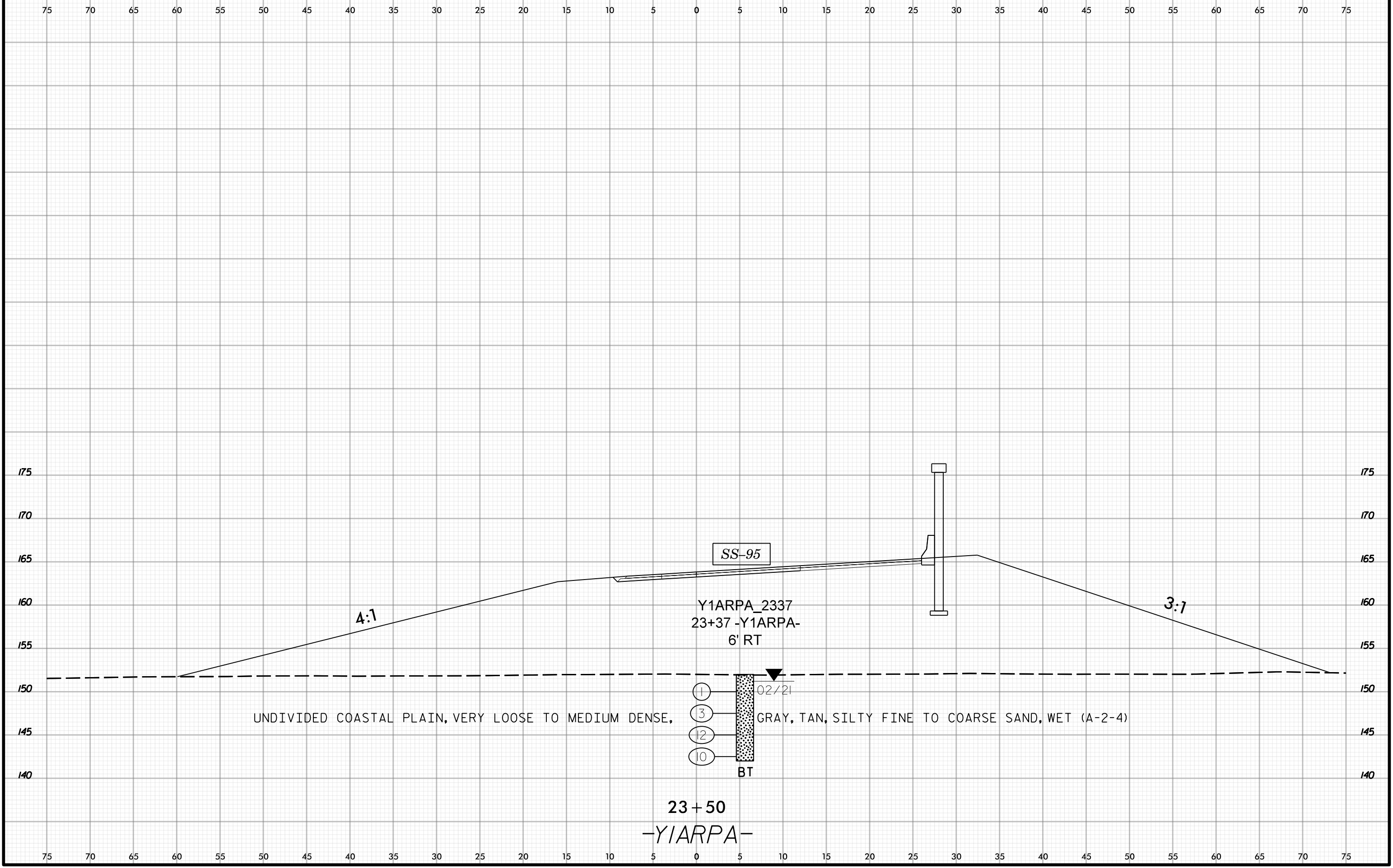

UNDIVIDED COASTAL PLAIN, VERY LOOSE TO MEDIUM DENSE,

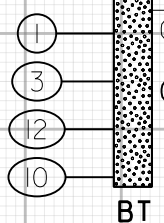

02/21
GRAY, TAN, SILTY FINE TO COARSE SAND, WET (A-2-4)

23 + 50
-Y1ARPA-

Y1ARPA_2337
23+37 -Y1ARPA-
6' RT

SS-95

4:1

3:1

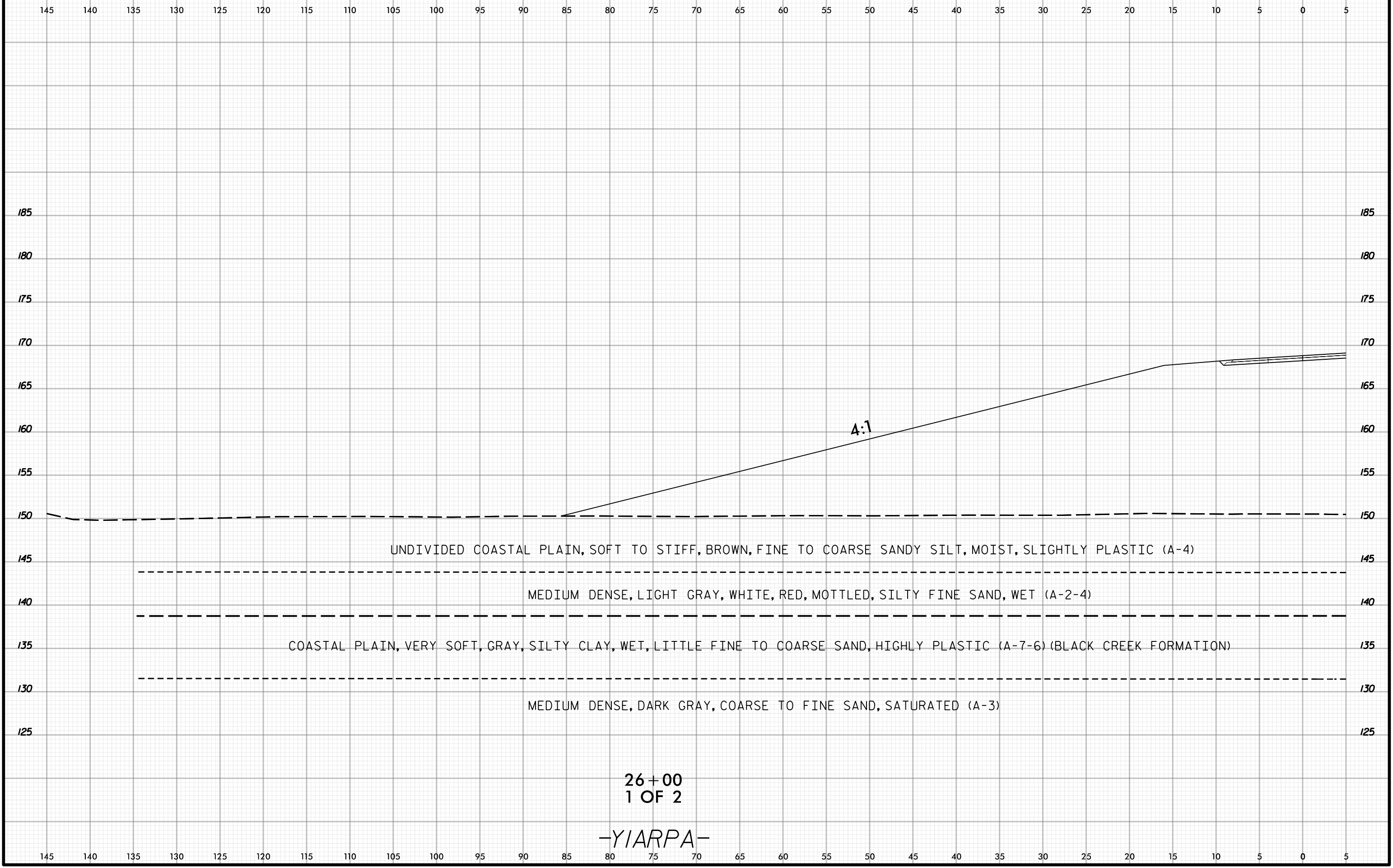
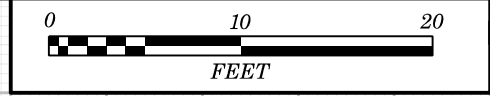

26+00
1 OF 2
-YIARPA-

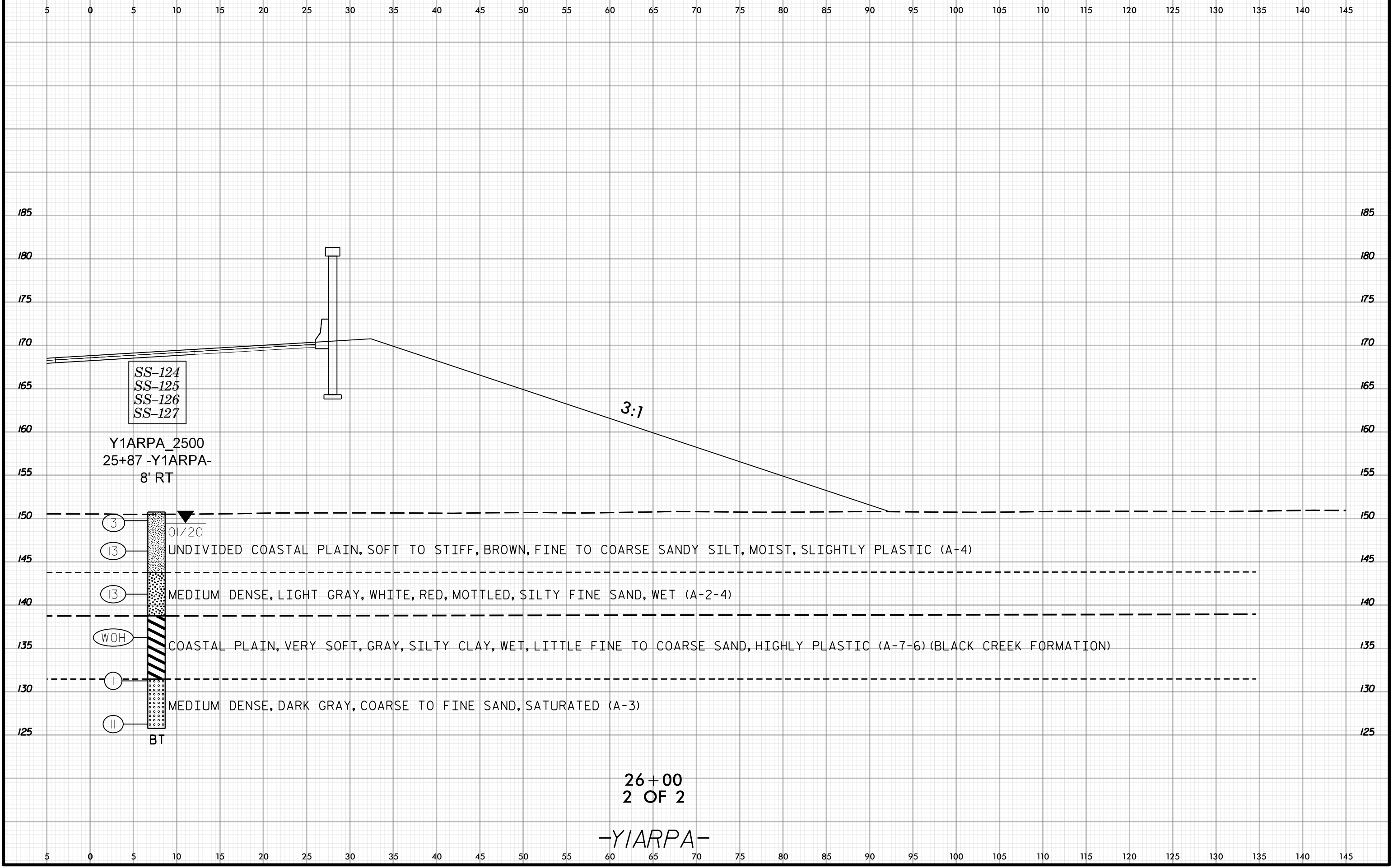

SS-124
SS-125
SS-126
SS-127

Y1ARPA_2500
25+87 -Y1ARPA-
8' RT

3:1

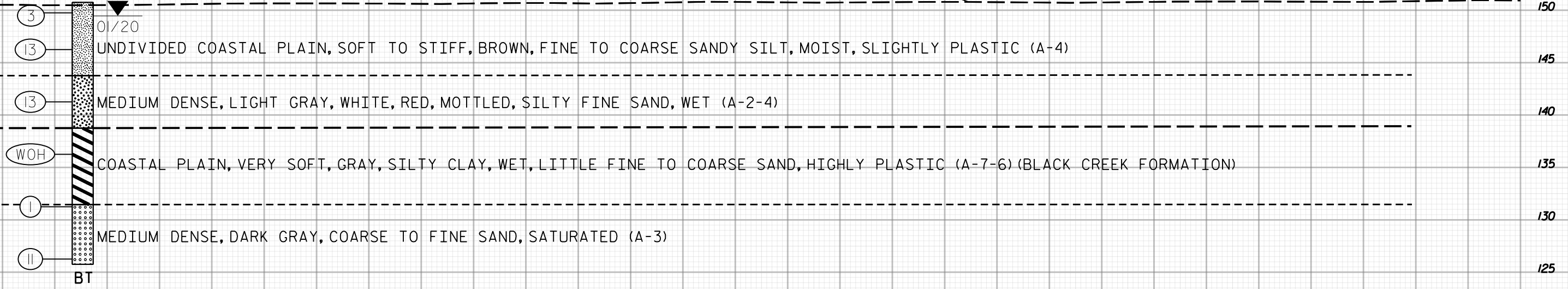

26+00
2 OF 2

-Y1ARPA-

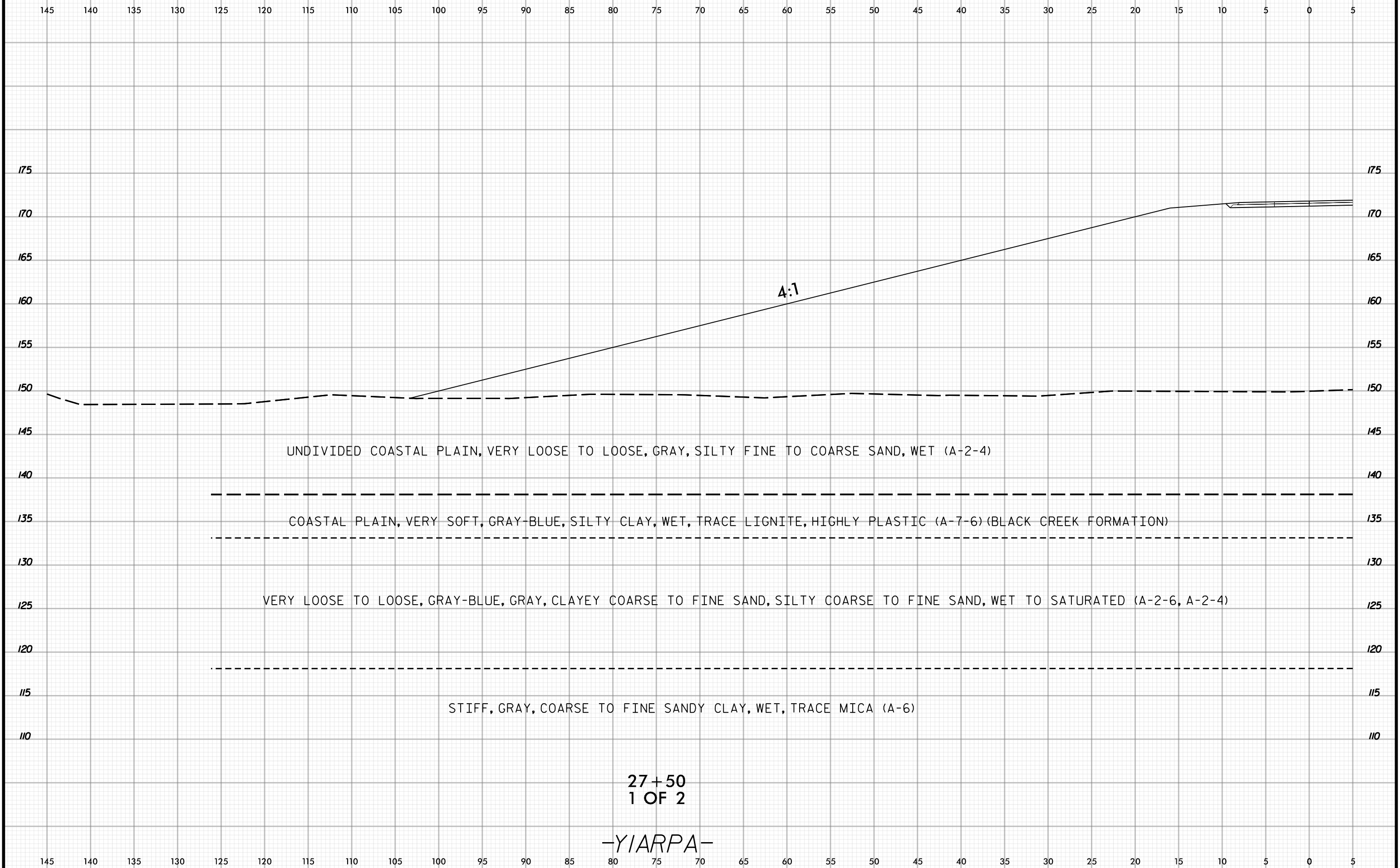

27+50
1 OF 2

-YIARPA-

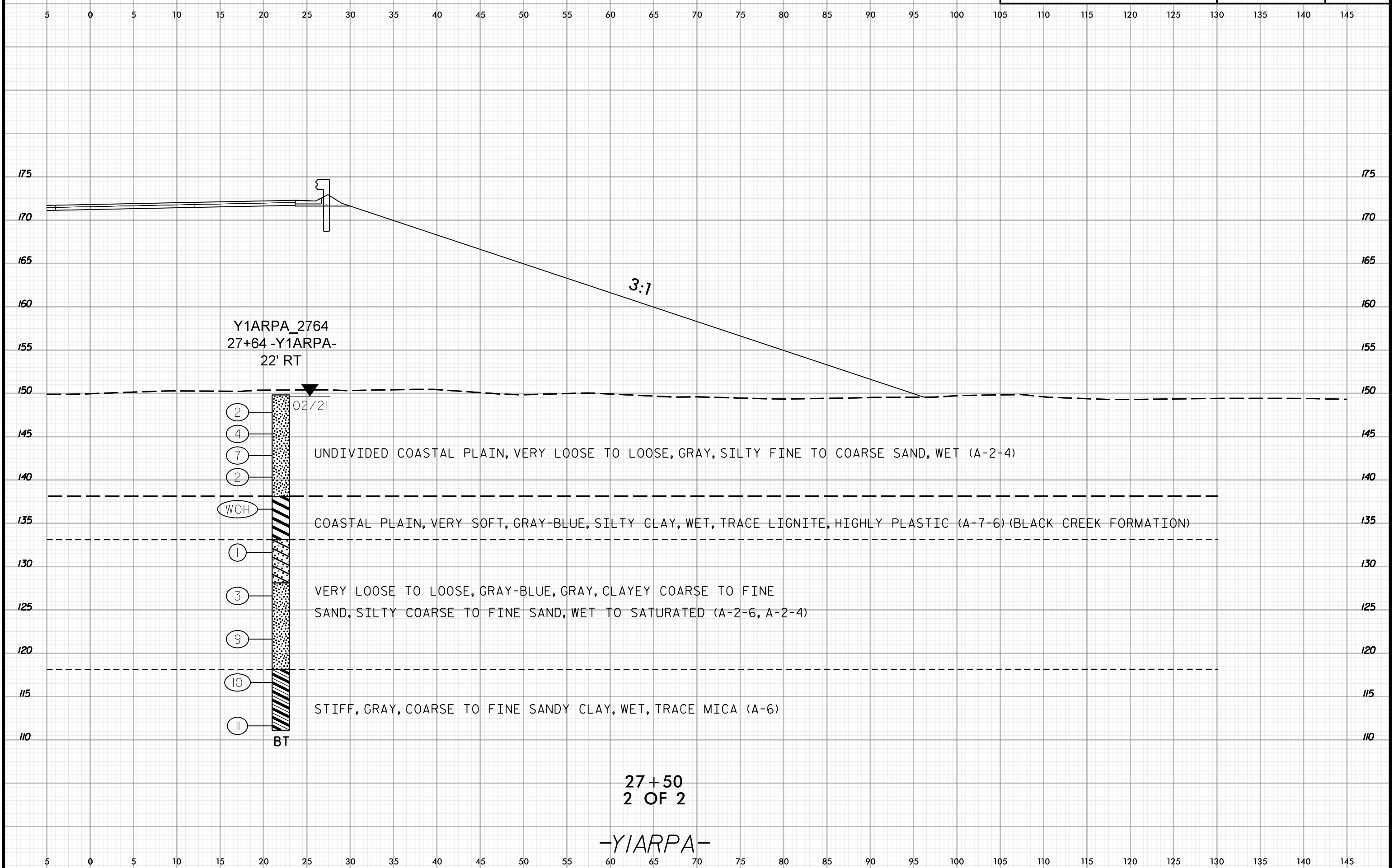

Y1ARPA_2764
27+64 -Y1ARPA-
22' RT

3:1

02/21

2

4

7

2

WOH

1

3

9

10

11

BT

UNDIVIDED COASTAL PLAIN, VERY LOOSE TO LOOSE, GRAY, SILTY FINE TO COARSE SAND, WET (A-2-4)

COASTAL PLAIN, VERY SOFT, GRAY-BLUE, SILTY CLAY, WET, TRACE LIGNITE, HIGHLY PLASTIC (A-7-6) (BLACK CREEK FORMATION)

VERY LOOSE TO LOOSE, GRAY-BLUE, GRAY, CLAYEY COARSE TO FINE SAND, SILTY COARSE TO FINE SAND, WET TO SATURATED (A-2-6, A-2-4)

STIFF, GRAY, COARSE TO FINE SANDY CLAY, WET, TRACE MICA (A-6)

27+50
2 OF 2

-Y1ARPA-

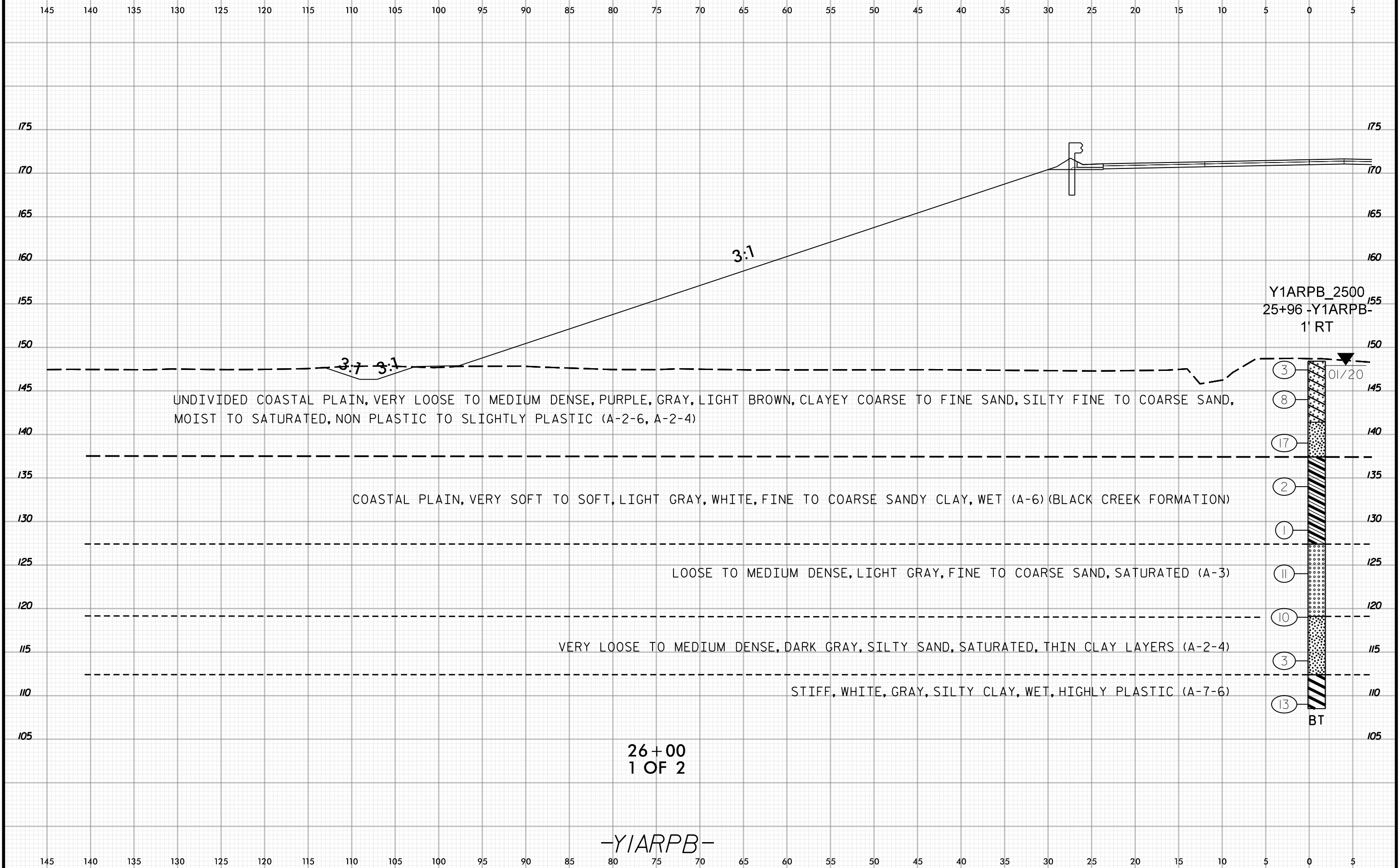

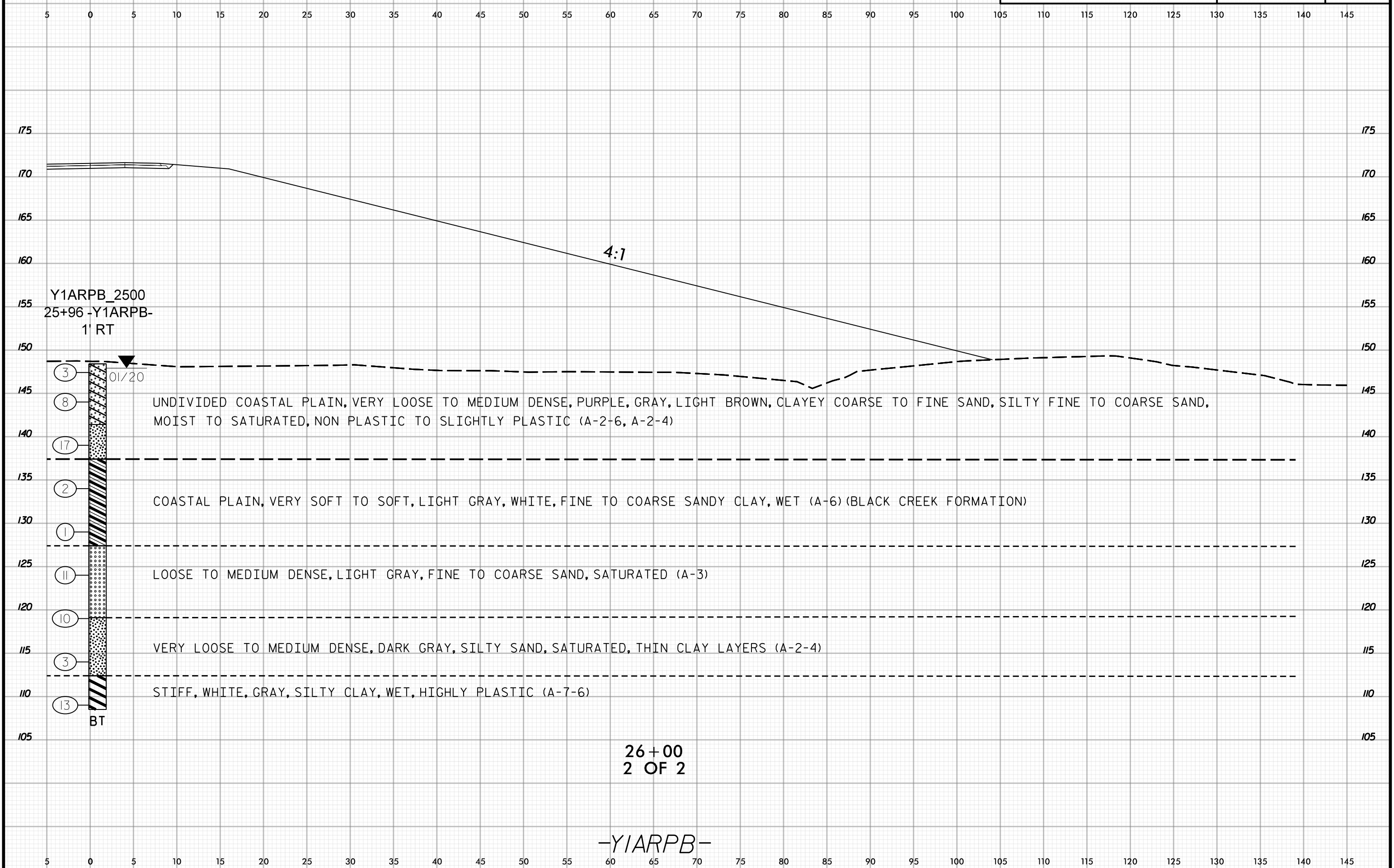



145 140 135 130 125 120 115 110 105 100 95 90 85 80 75 70 65 60 55 50 45 40 35 30 25 20 15 10 5 0 5

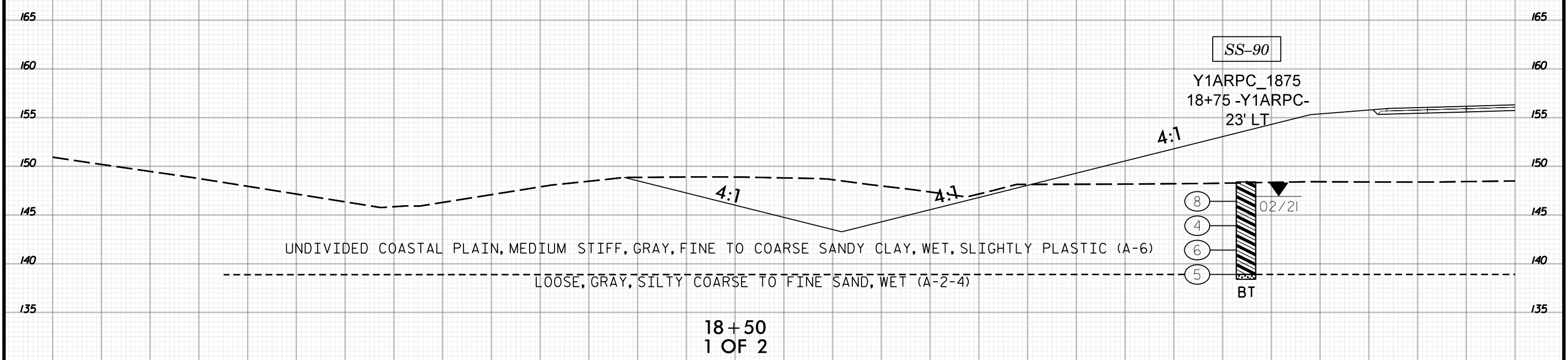
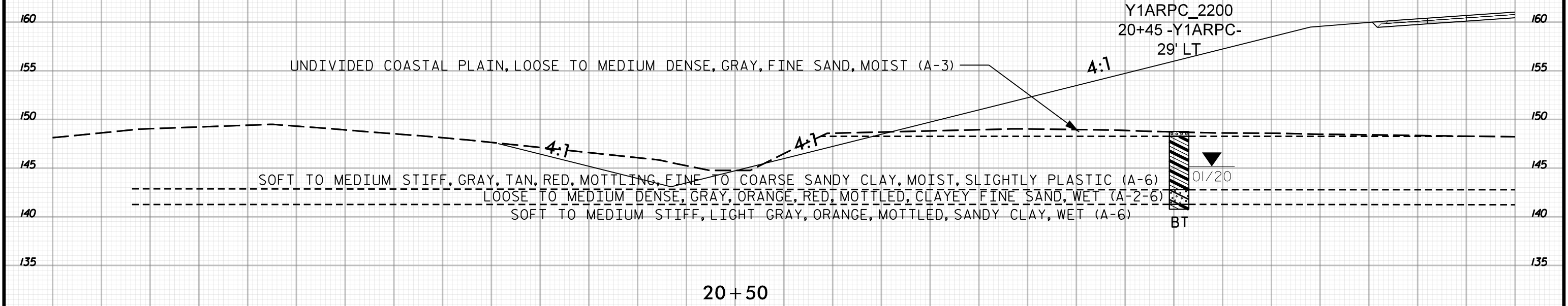

145 140 135 130 125 120 115 110 105 100 95 90 85 80 75 70 65 60 55 50 45 40 35 30 25 20 15 10 5 0 5

-YIARPC-

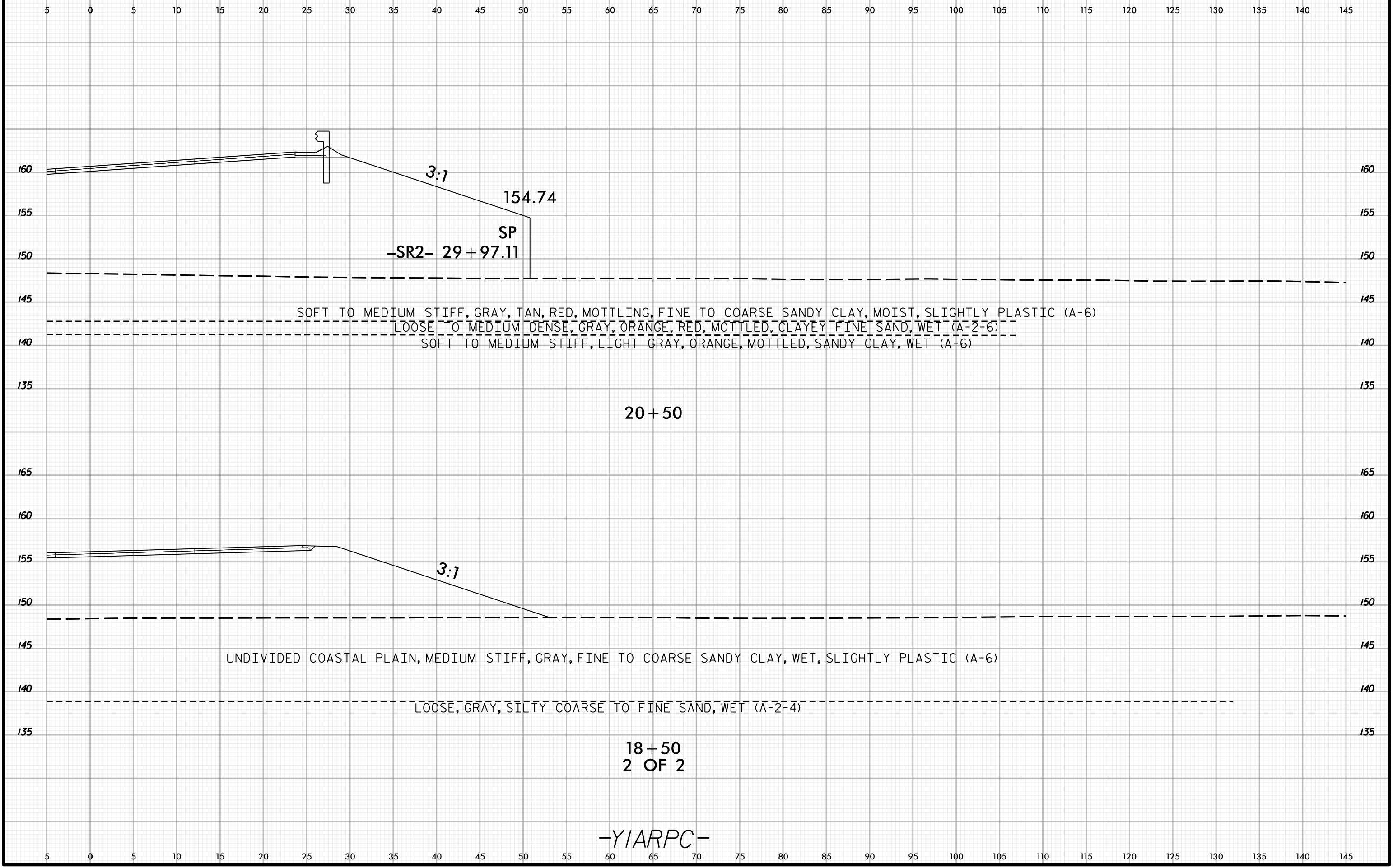

-YIARPC-

18+50
2 OF 2

-SR2- 29+97.11

SP

3:1

154.74

3:1

UNDIVIDED COASTAL PLAIN, MEDIUM STIFF, GRAY, FINE TO COARSE SANDY CLAY, WET, SLIGHTLY PLASTIC (A-6)

LOOSE, GRAY, SILTY COARSE TO FINE SAND, WET (A-2-4)

SOFT TO MEDIUM STIFF, GRAY, TAN, RED, MOTTLING, FINE TO COARSE SANDY CLAY, MOIST, SLIGHTLY PLASTIC (A-6)

LOOSE TO MEDIUM DENSE, GRAY, ORANGE, RED, MOTTLED, CLAYEY FINE SAND, WET (A-2-6)

SOFT TO MEDIUM STIFF, LIGHT GRAY, ORANGE, MOTTLED, SANDY CLAY, WET (A-6)

20+50

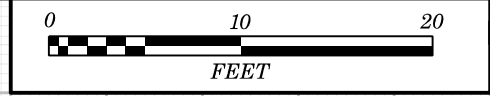

145 140 135 130 125 120 115 110 105 100 95 90 85 80 75 70 65 60 55 50 45 40 35 30 25 20 15 10 5 0 5

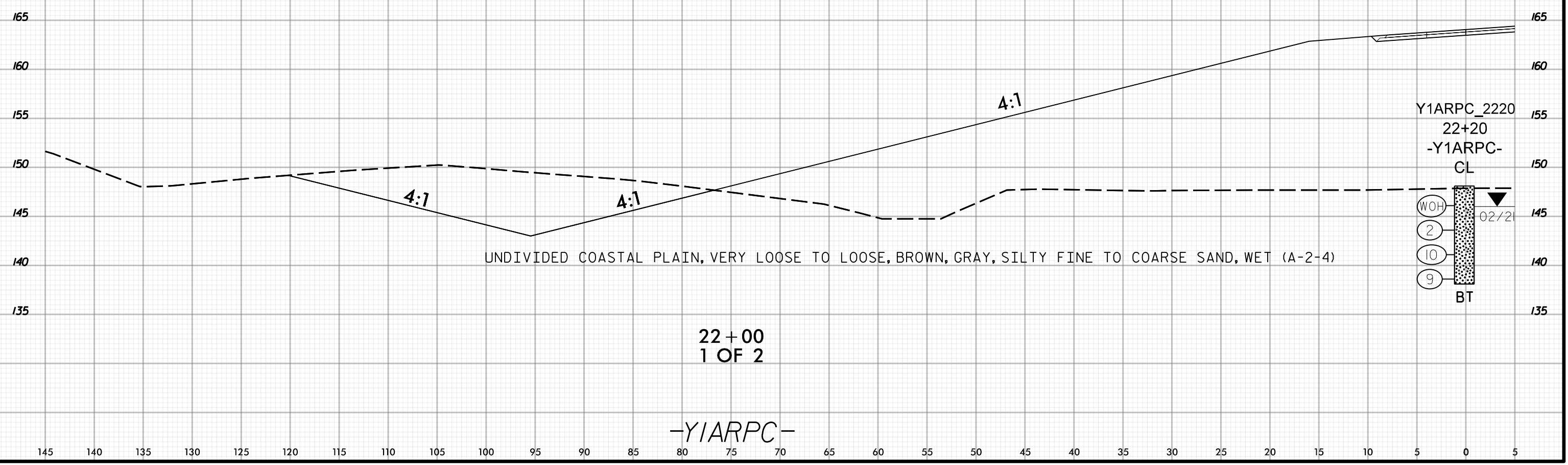

145 140 135 130 125 120 115 110 105 100 95 90 85 80 75 70 65 60 55 50 45 40 35 30 25 20 15 10 5 0 5

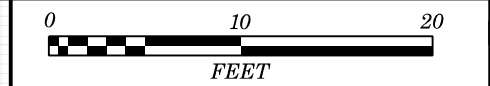

5 0 5 10 15 20 25 30 35 40 45 50 55 60 65 70 75 80 85 90 95 100 105 110 115 120 125 130 135 140 145

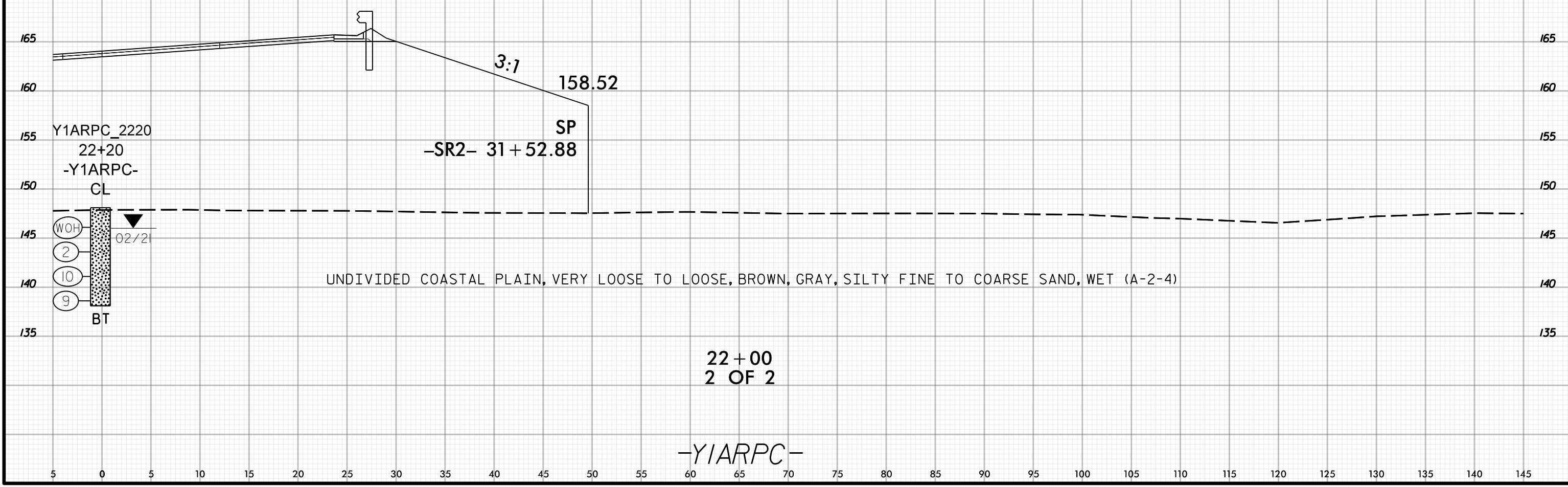

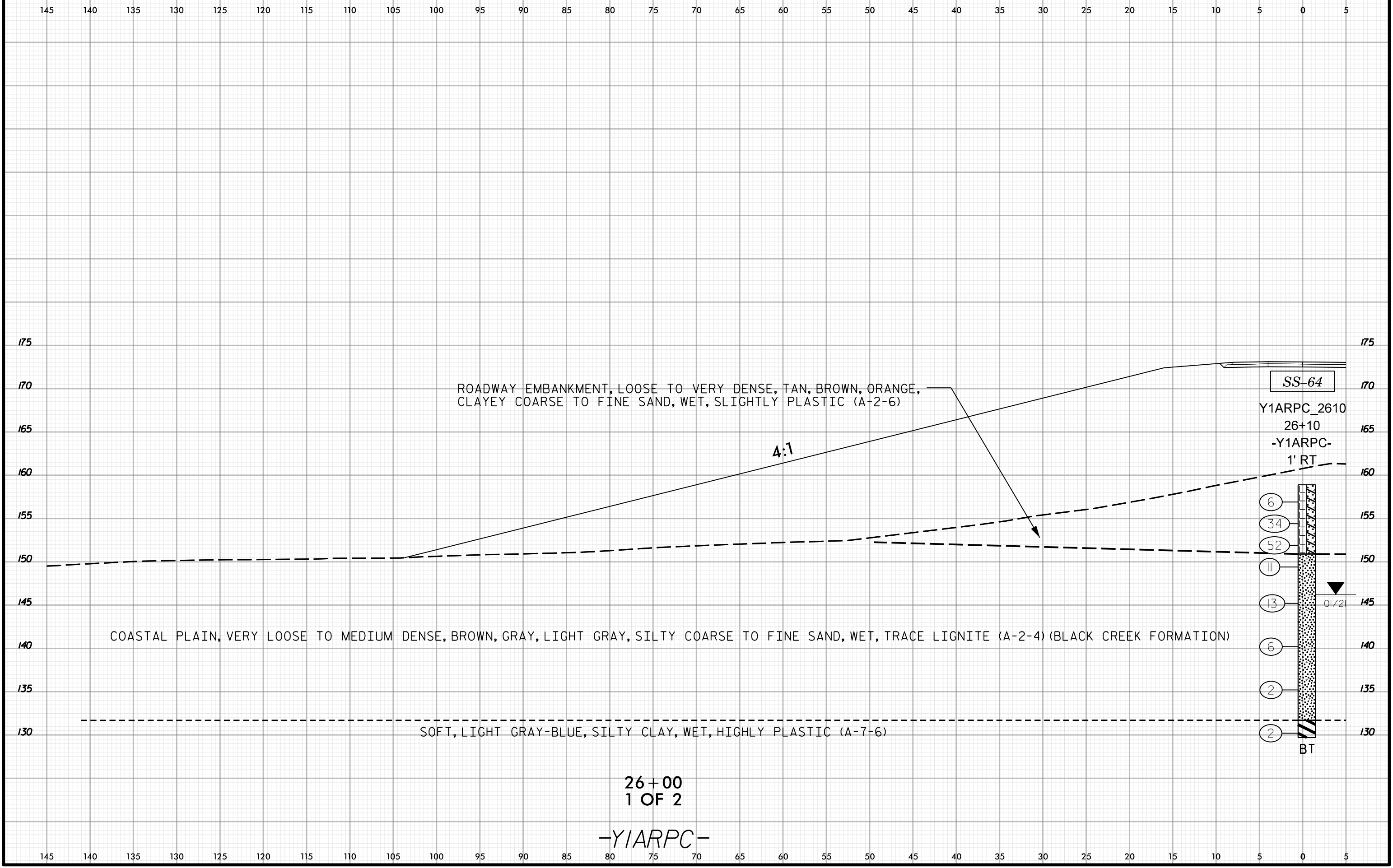
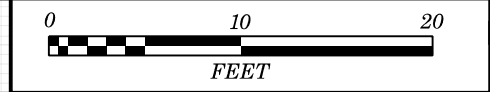

ROADWAY EMBANKMENT, LOOSE TO VERY DENSE, TAN, BROWN, ORANGE, CLAYEY COARSE TO FINE SAND, WET, SLIGHTLY PLASTIC (A-2-6)

4:1

COASTAL PLAIN, VERY LOOSE TO MEDIUM DENSE, BROWN, GRAY, LIGHT GRAY, SILTY COARSE TO FINE SAND, WET, TRACE LIGNITE (A-2-4) (BLACK CREEK FORMATION)

SOFT, LIGHT GRAY-BLUE, SILTY CLAY, WET, HIGHLY PLASTIC (A-7-6)

SS-64

Y1ARPC_2610
26+10
-Y1ARPC-
1' RT

- 6
 - 34
 - 52
 - 11
 - 13
 - 6
 - 2
 - 2
- BT



01/21

26+00
1 OF 2

-Y1ARPC-



5 0 5 10 15 20 25 30 35 40 45 50 55 60 65 70 75 80 85 90 95 100 105 110 115 120 125 130 135 140 145

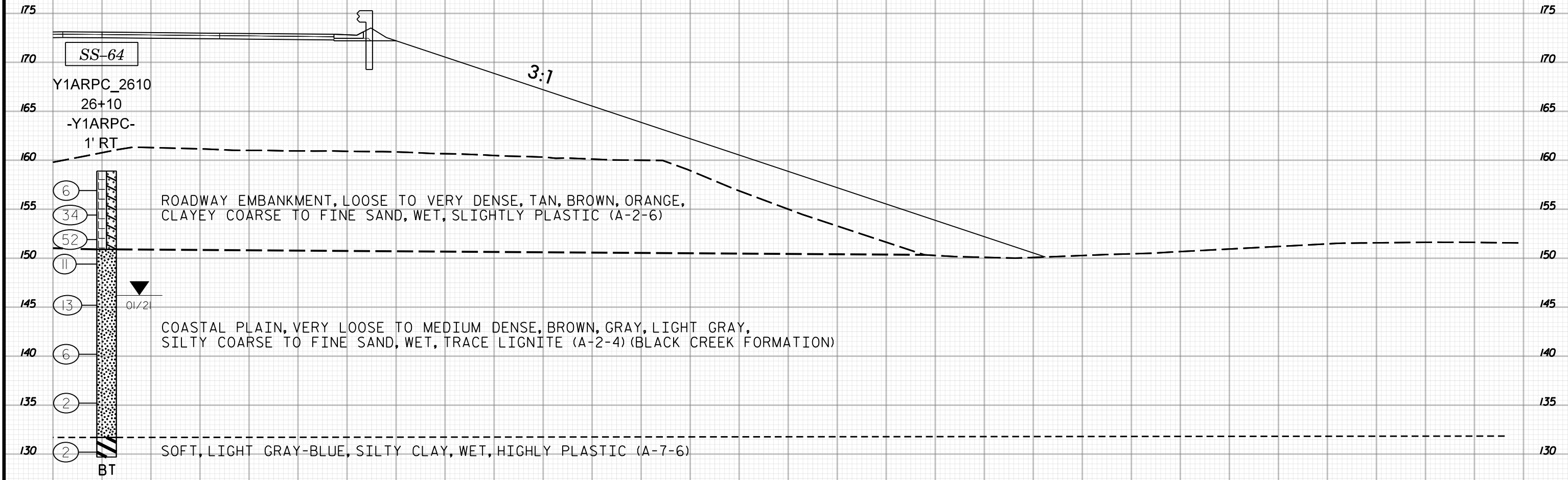

26+00
2 OF 2
-Y1ARPC-

5 0 5 10 15 20 25 30 35 40 45 50 55 60 65 70 75 80 85 90 95 100 105 110 115 120 125 130 135 140 145

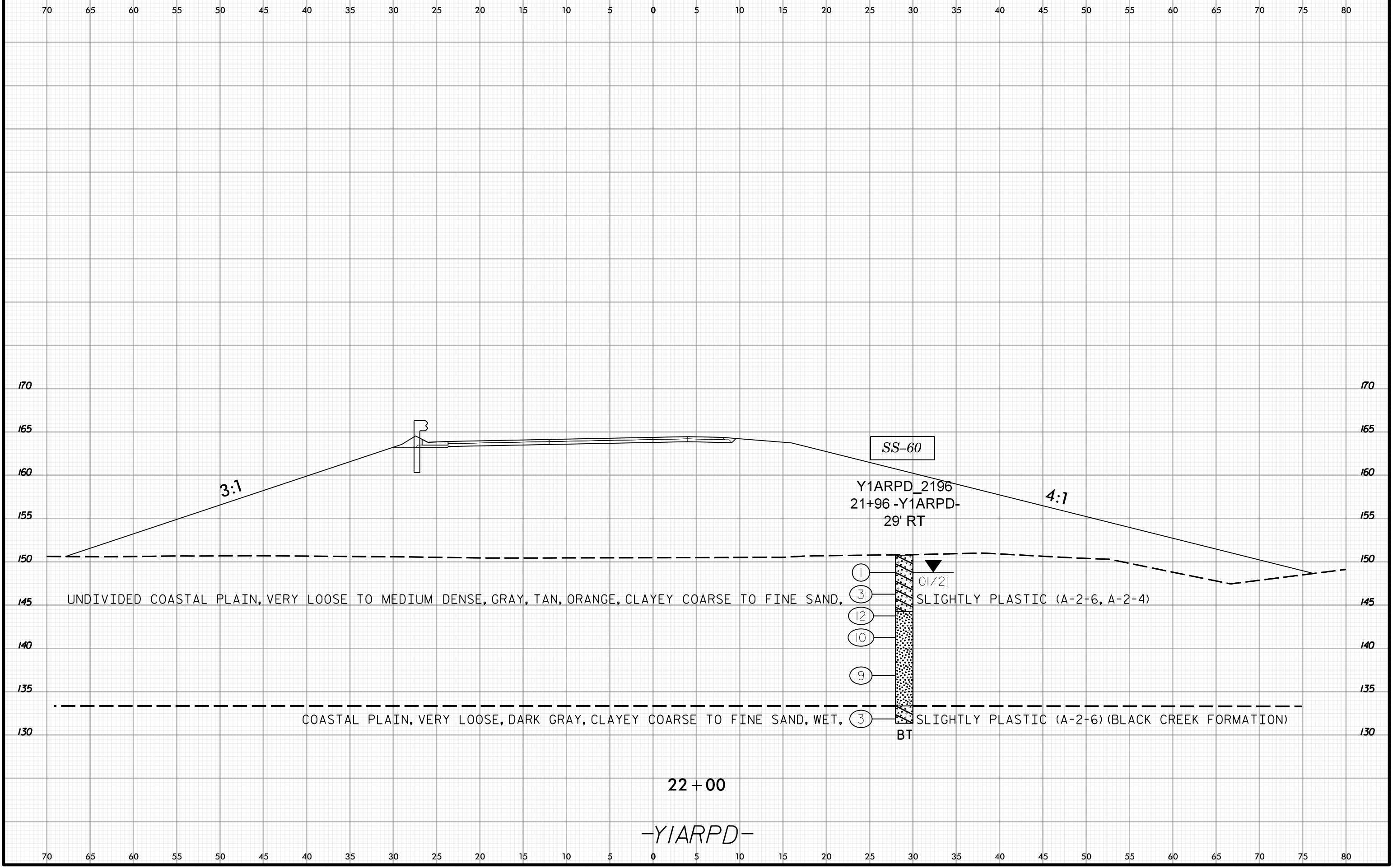

22 + 00

-Y1ARPD-

SS-60

Y1ARPD_2196
21+96 -Y1ARPD-
29' RT

- ①
- ③
- ⑫
- ⑩
- ⑨
- ③

01/21
SLIGHTLY PLASTIC (A-2-6, A-2-4)

BT
SLIGHTLY PLASTIC (A-2-6) (BLACK CREEK FORMATION)

UNDIVIDED COASTAL PLAIN, VERY LOOSE TO MEDIUM DENSE, GRAY, TAN, ORANGE, CLAYEY COARSE TO FINE SAND,

COASTAL PLAIN, VERY LOOSE, DARK GRAY, CLAYEY COARSE TO FINE SAND, WET,

3:1

4:1

170
165
160
155
150
145
140
135
130

170
165
160
155
150
145
140
135
130

70 65 60 55 50 45 40 35 30 25 20 15 10 5 0 5 10 15 20 25 30 35 40 45 50 55 60 65 70 75 80

70 65 60 55 50 45 40 35 30 25 20 15 10 5 0 5 10 15 20 25 30 35 40 45 50 55 60 65 70 75 80

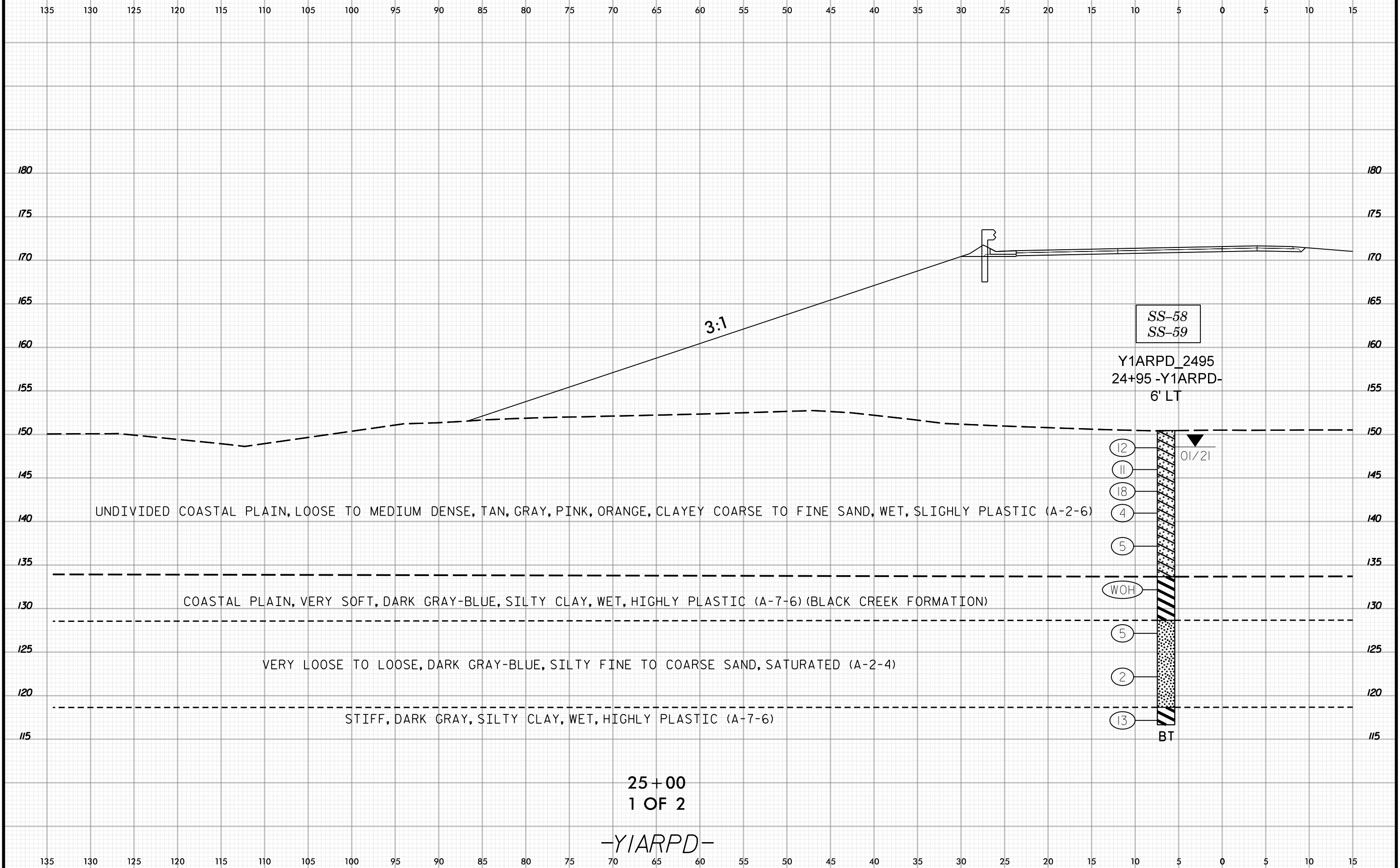

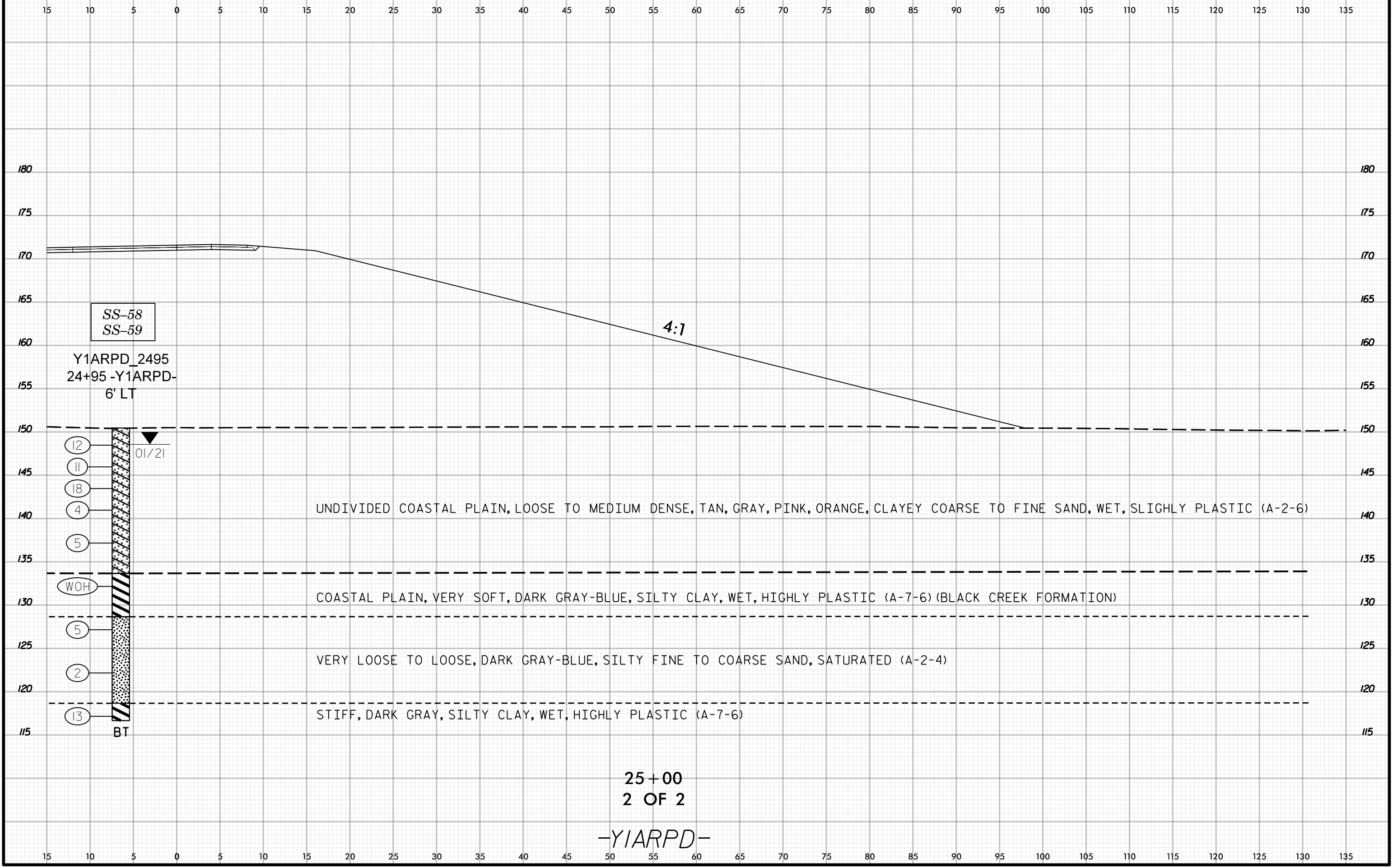
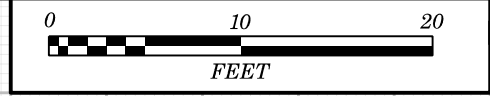

25+00
2 OF 2
-YIARPD-



145 140 135 130 125 120 115 110 105 100 95 90 85 80 75 70 65 60 55 50 45 40 35 30 25 20 15 10 5 0 5

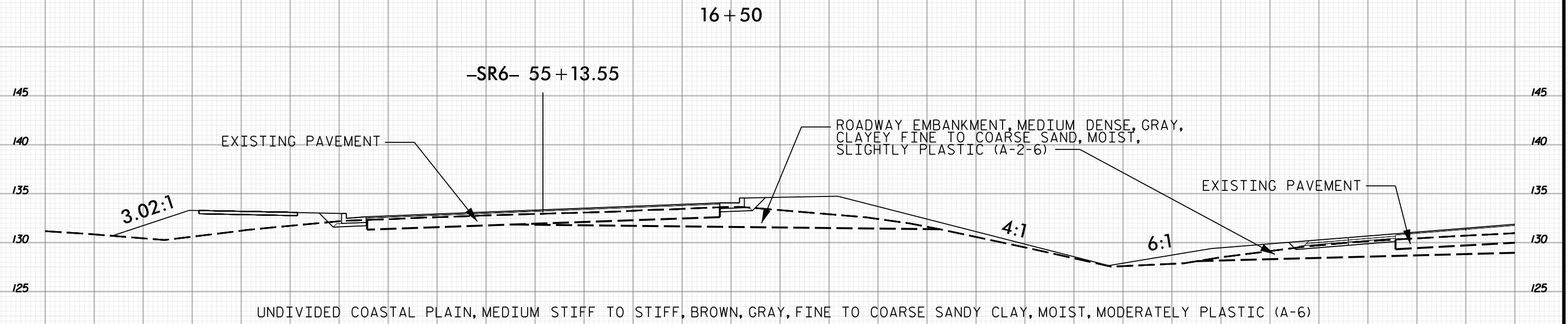
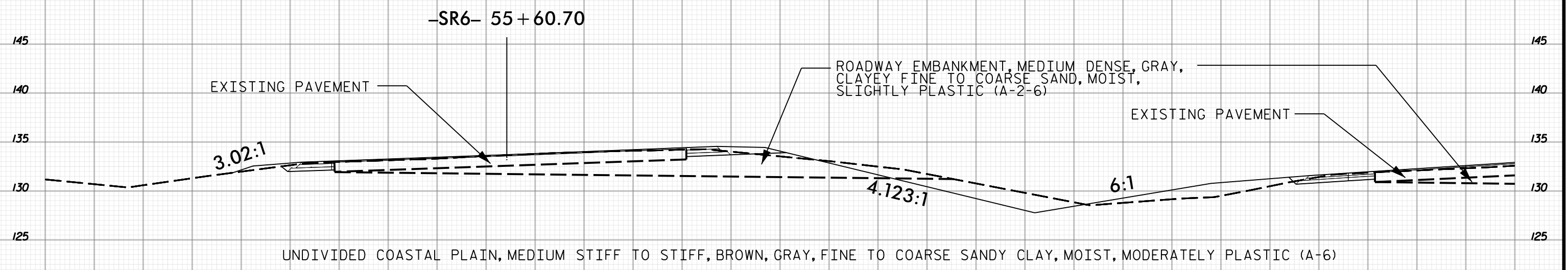

16 + 50

16 + 00
1 OF 2

-YIRPB-

145 140 135 130 125 120 115 110 105 100 95 90 85 80 75 70 65 60 55 50 45 40 35 30 25 20 15 10 5 0 5



5 0 5 10 15 20 25 30 35 40 45 50 55 60 65 70 75 80 85 90 95 100 105 110 115 120 125 130 135 140 145

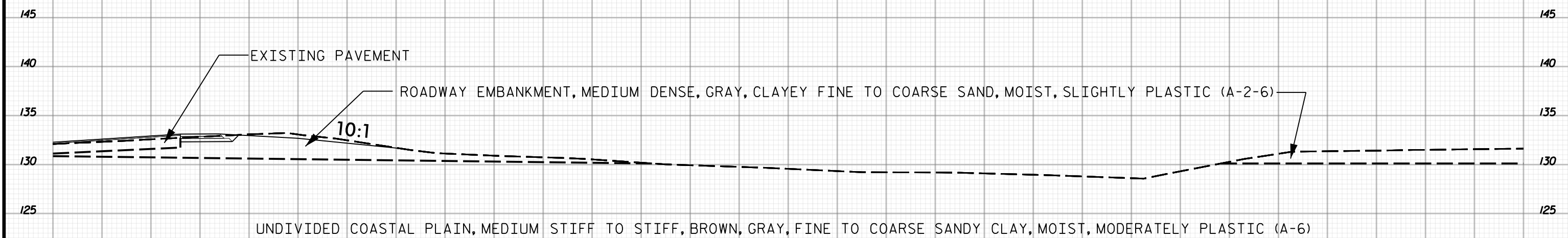

16+50

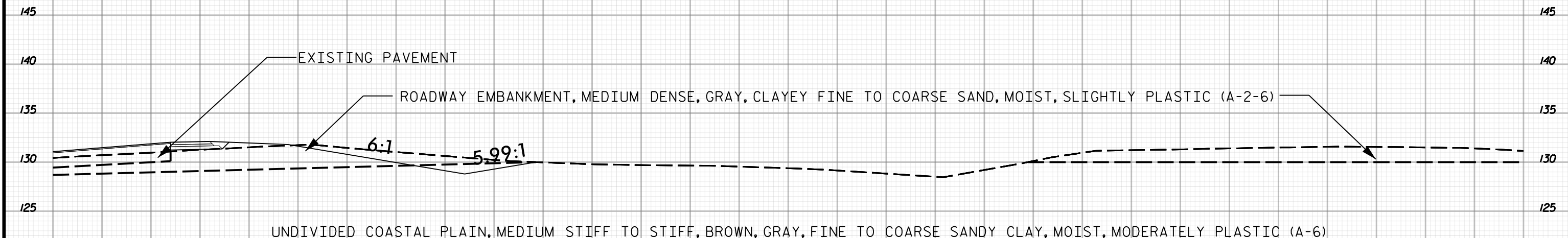

16+00

2 OF 2

-YIRPB-

5 0 5 10 15 20 25 30 35 40 45 50 55 60 65 70 75 80 85 90 95 100 105 110 115 120 125 130 135 140 145

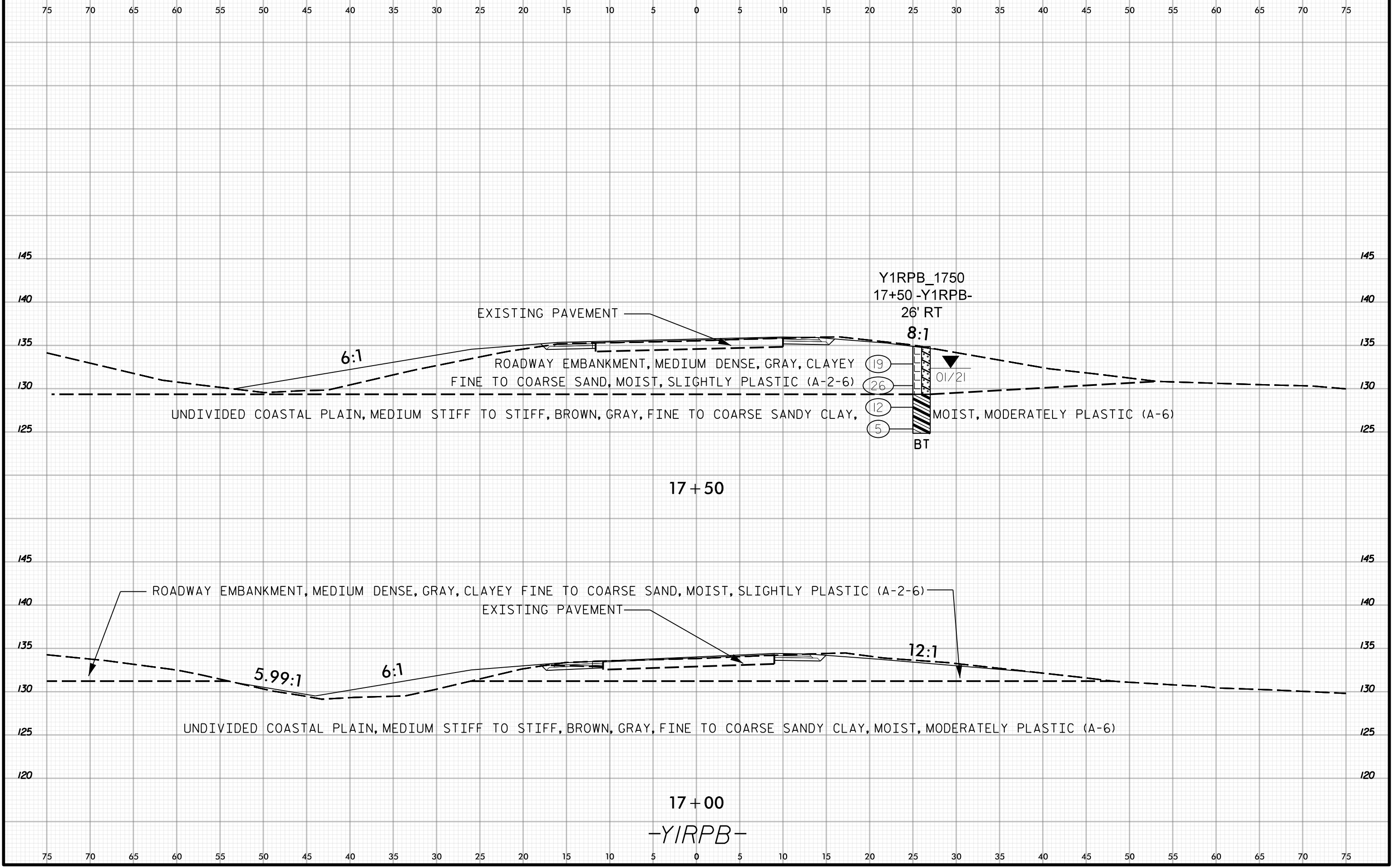
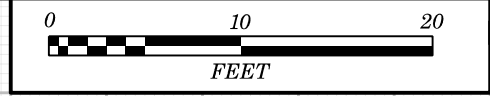

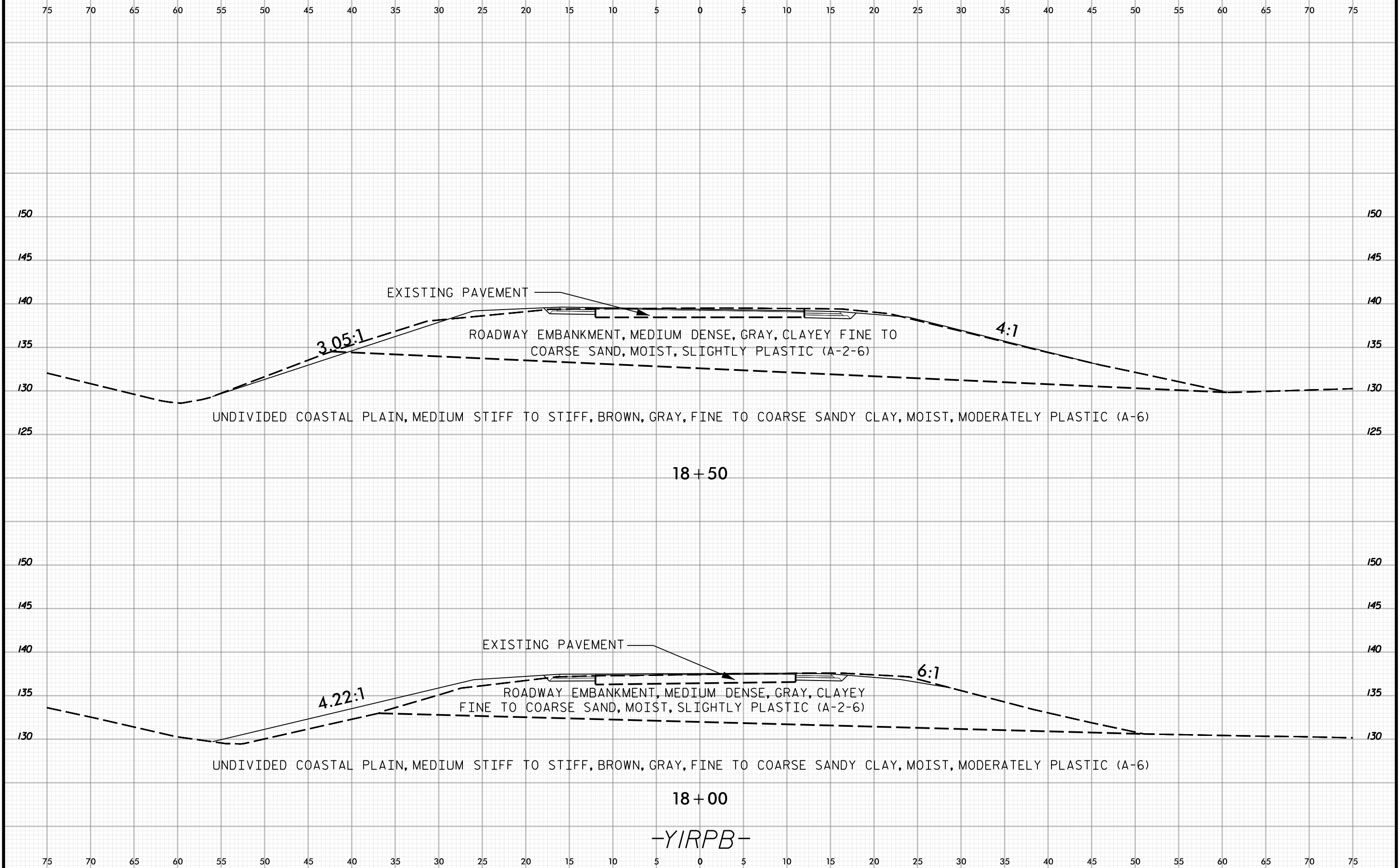



75 70 65 60 55 50 45 40 35 30 25 20 15 10 5 0 5 10 15 20 25 30 35 40 45 50 55 60 65 70 75

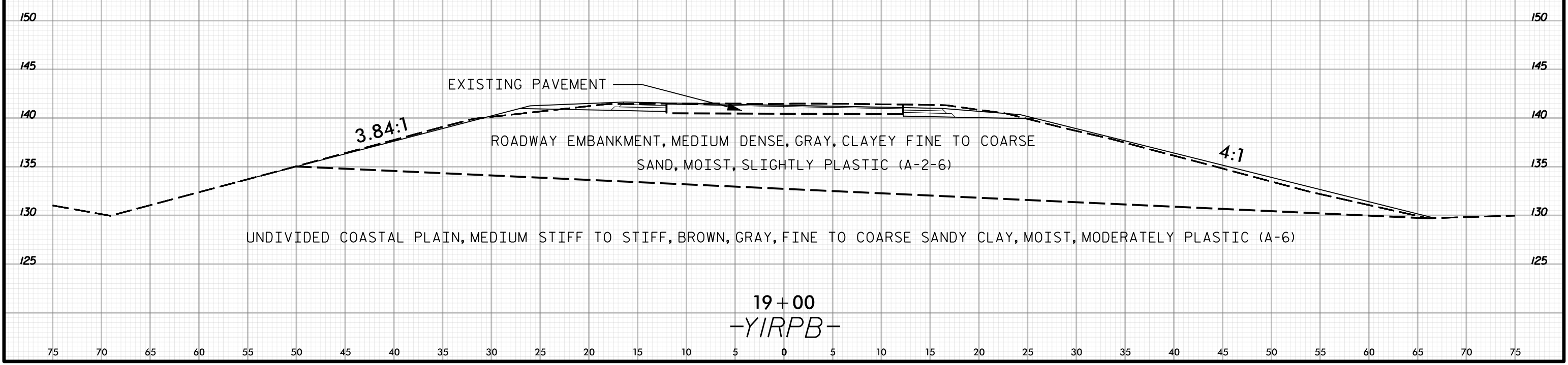
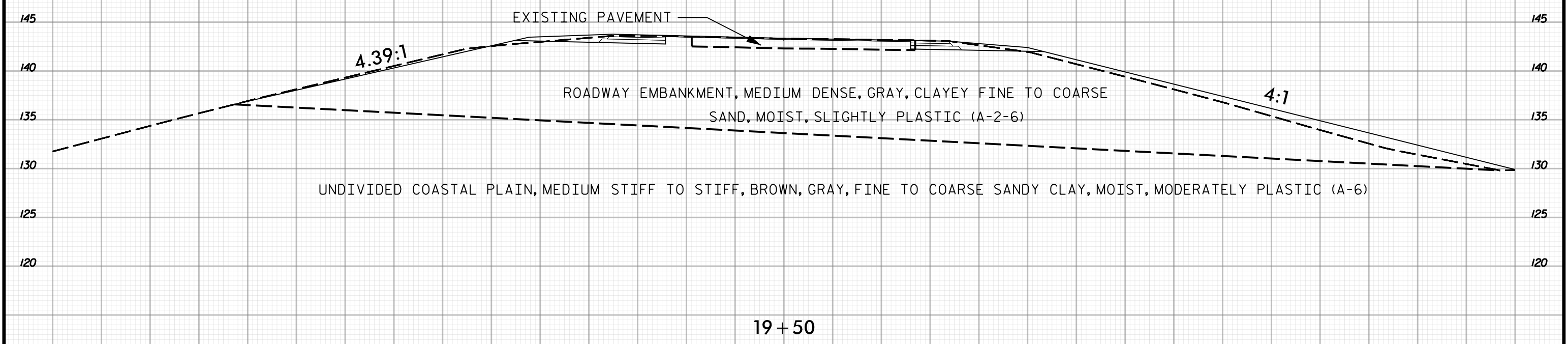

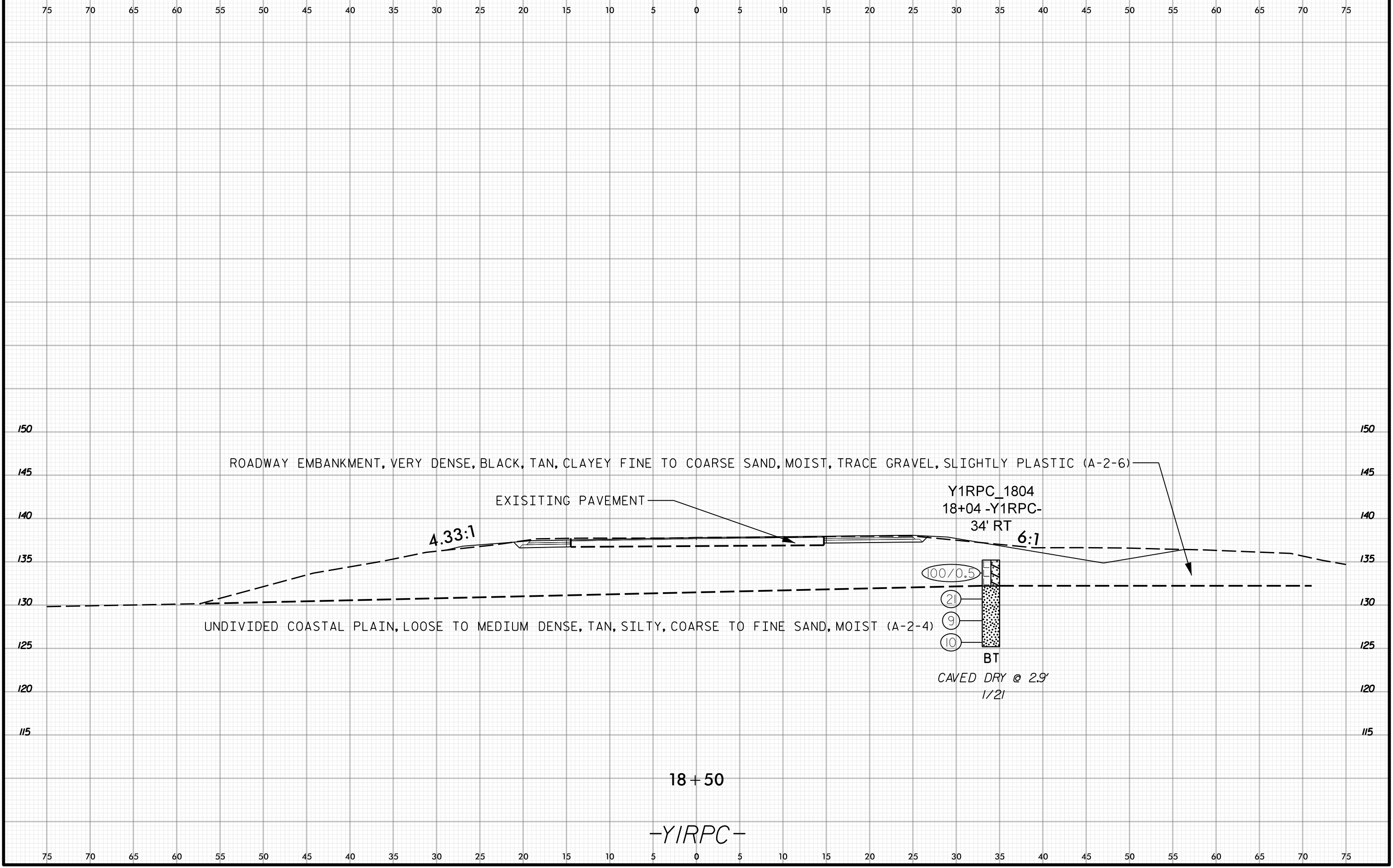



75 70 65 60 55 50 45 40 35 30 25 20 15 10 5 0 5 10 15 20 25 30 35 40 45 50 55 60 65 70 75

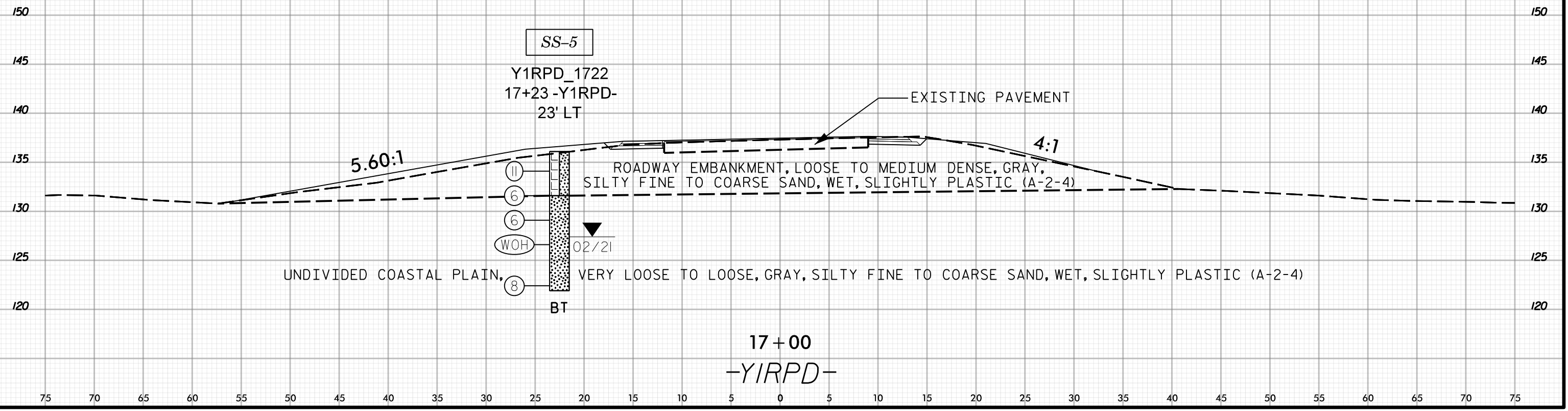

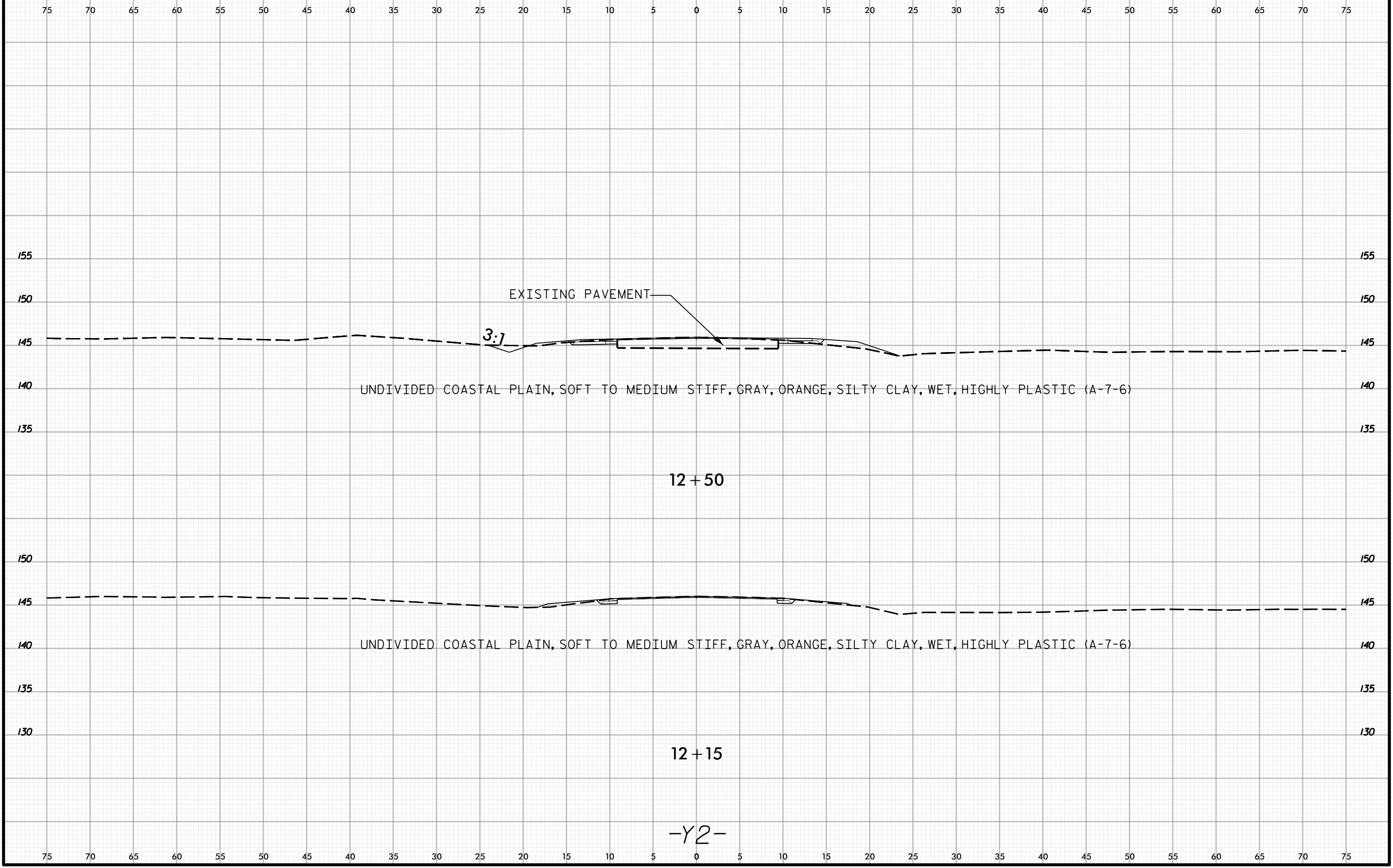

3:1

EXISTING PAVEMENT

UNDIVIDED COASTAL PLAIN, SOFT TO MEDIUM STIFF, GRAY, ORANGE, SILTY CLAY, WET, HIGHLY PLASTIC (A-7-6)

12+50

UNDIVIDED COASTAL PLAIN, SOFT TO MEDIUM STIFF, GRAY, ORANGE, SILTY CLAY, WET, HIGHLY PLASTIC (A-7-6)

12+15

-Y2-



PROJ. REFERENCE NO.	SHEET NO.
I-5987A	950

75 70 65 60 55 50 45 40 35 30 25 20 15 10 5 0 5 10 15 20 25 30 35 40 45 50 55 60 65 70 75

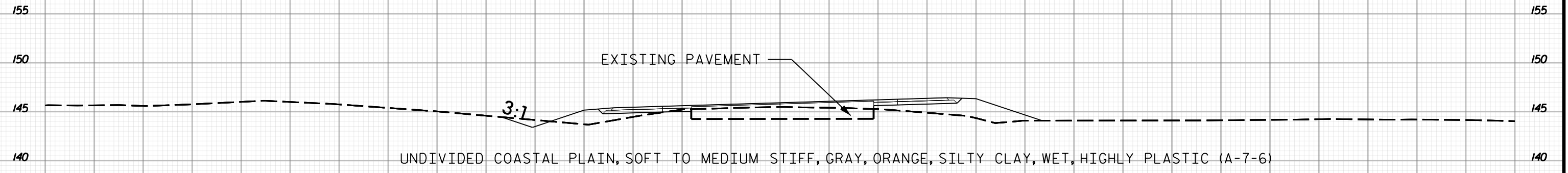

13+50

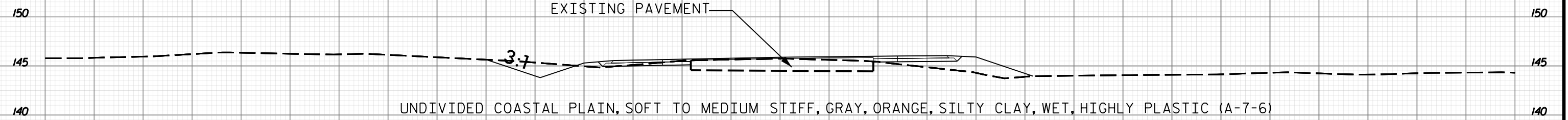

13+00

-Y2-

75 70 65 60 55 50 45 40 35 30 25 20 15 10 5 0 5 10 15 20 25 30 35 40 45 50 55 60 65 70 75



PROJ. REFERENCE NO.	SHEET NO.
I-5987A	951

75 70 65 60 55 50 45 40 35 30 25 20 15 10 5 0 5 10 15 20 25 30 35 40 45 50 55 60 65 70 75

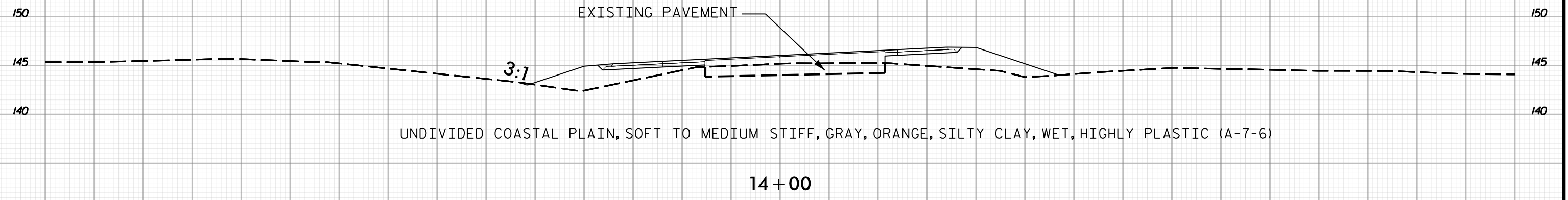
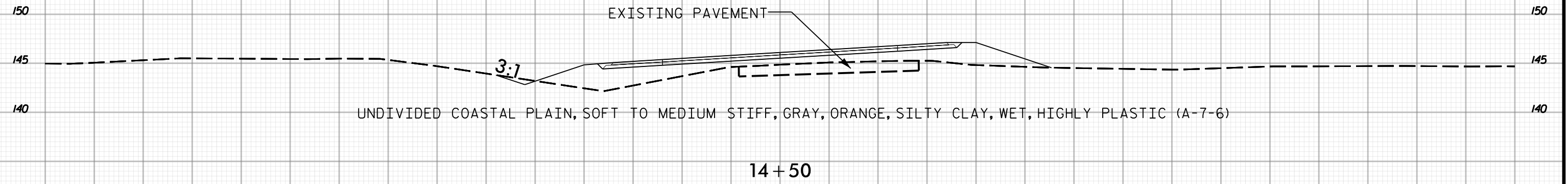

75 70 65 60 55 50 45 40 35 30 25 20 15 10 5 0 5 10 15 20 25 30 35 40 45 50 55 60 65 70 75



75 70 65 60 55 50 45 40 35 30 25 20 15 10 5 0 5 10 15 20 25 30 35 40 45 50 55 60 65 70 75

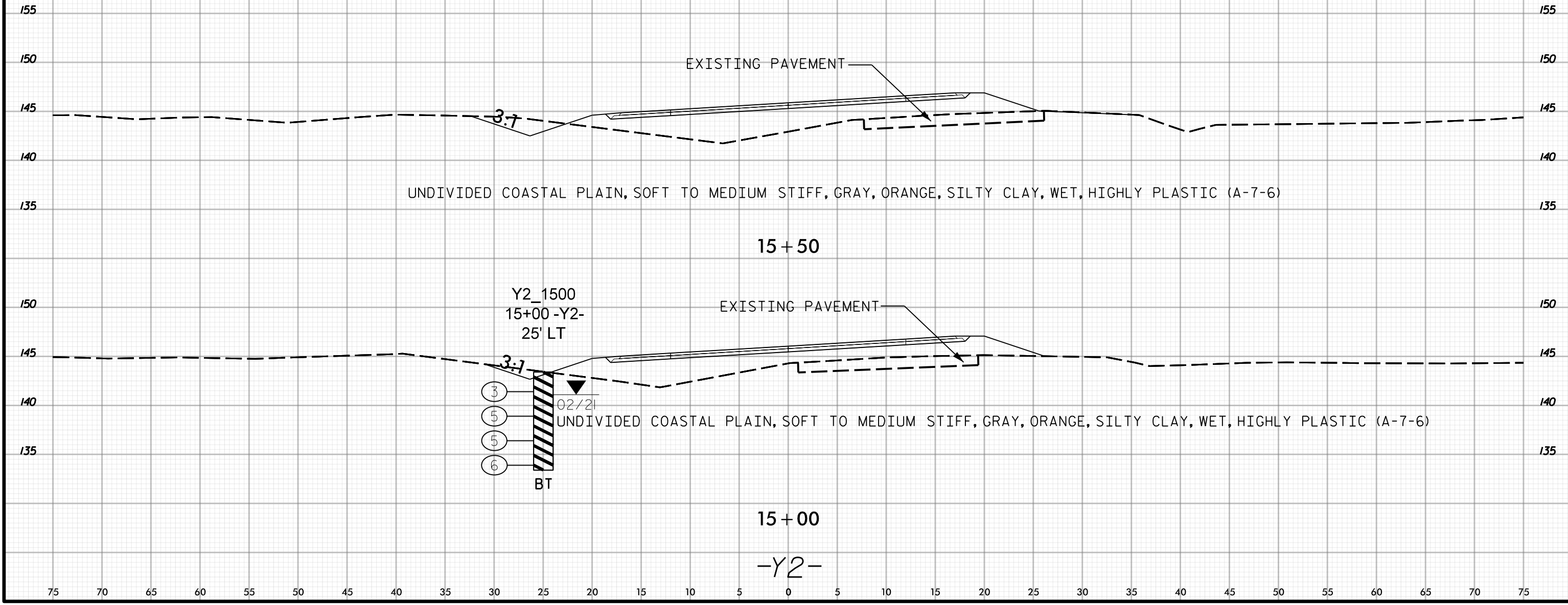



PROJ. REFERENCE NO.	SHEET NO.
I-5987A	953

75 70 65 60 55 50 45 40 35 30 25 20 15 10 5 0 5 10 15 20 25 30 35 40 45 50 55 60 65 70 75

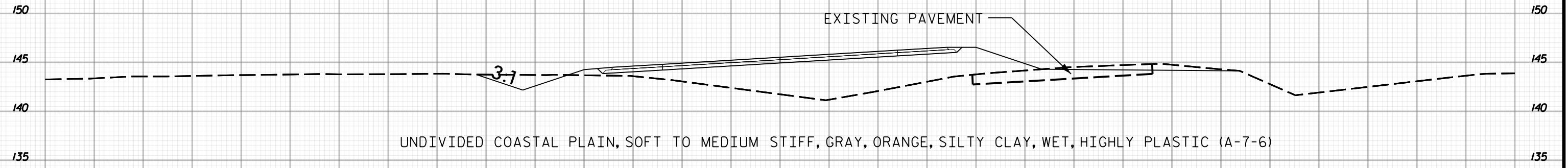

16+50



16+00

-Y2-

75 70 65 60 55 50 45 40 35 30 25 20 15 10 5 0 5 10 15 20 25 30 35 40 45 50 55 60 65 70 75



75 70 65 60 55 50 45 40 35 30 25 20 15 10 5 0 5 10 15 20 25 30 35 40 45 50 55 60 65 70 75

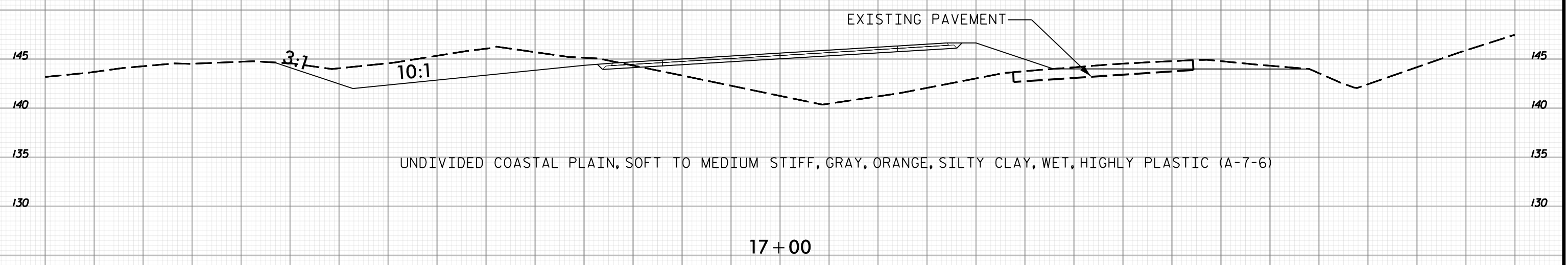
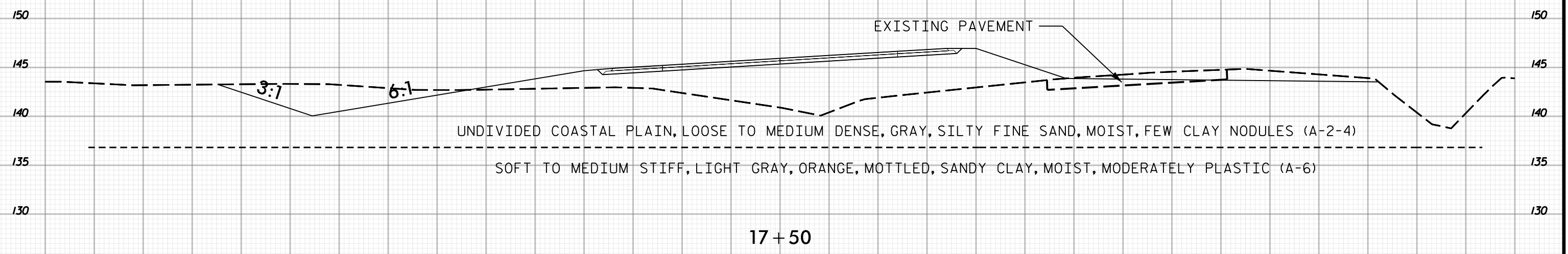

75 70 65 60 55 50 45 40 35 30 25 20 15 10 5 0 5 10 15 20 25 30 35 40 45 50 55 60 65 70 75



75 70 65 60 55 50 45 40 35 30 25 20 15 10 5 0 5 10 15 20 25 30 35 40 45 50 55 60 65 70 75

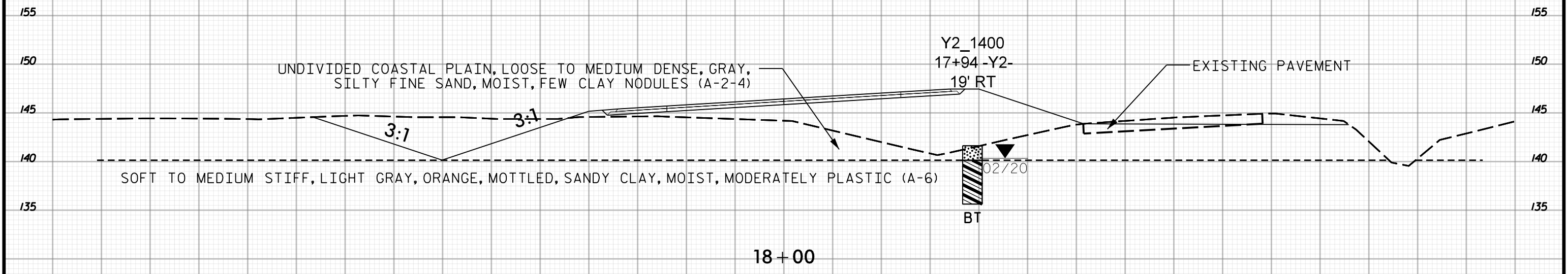
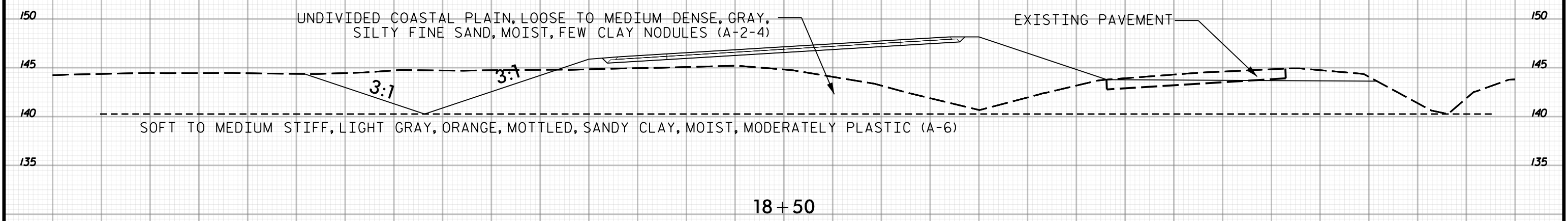

75 70 65 60 55 50 45 40 35 30 25 20 15 10 5 0 5 10 15 20 25 30 35 40 45 50 55 60 65 70 75

-Y2-

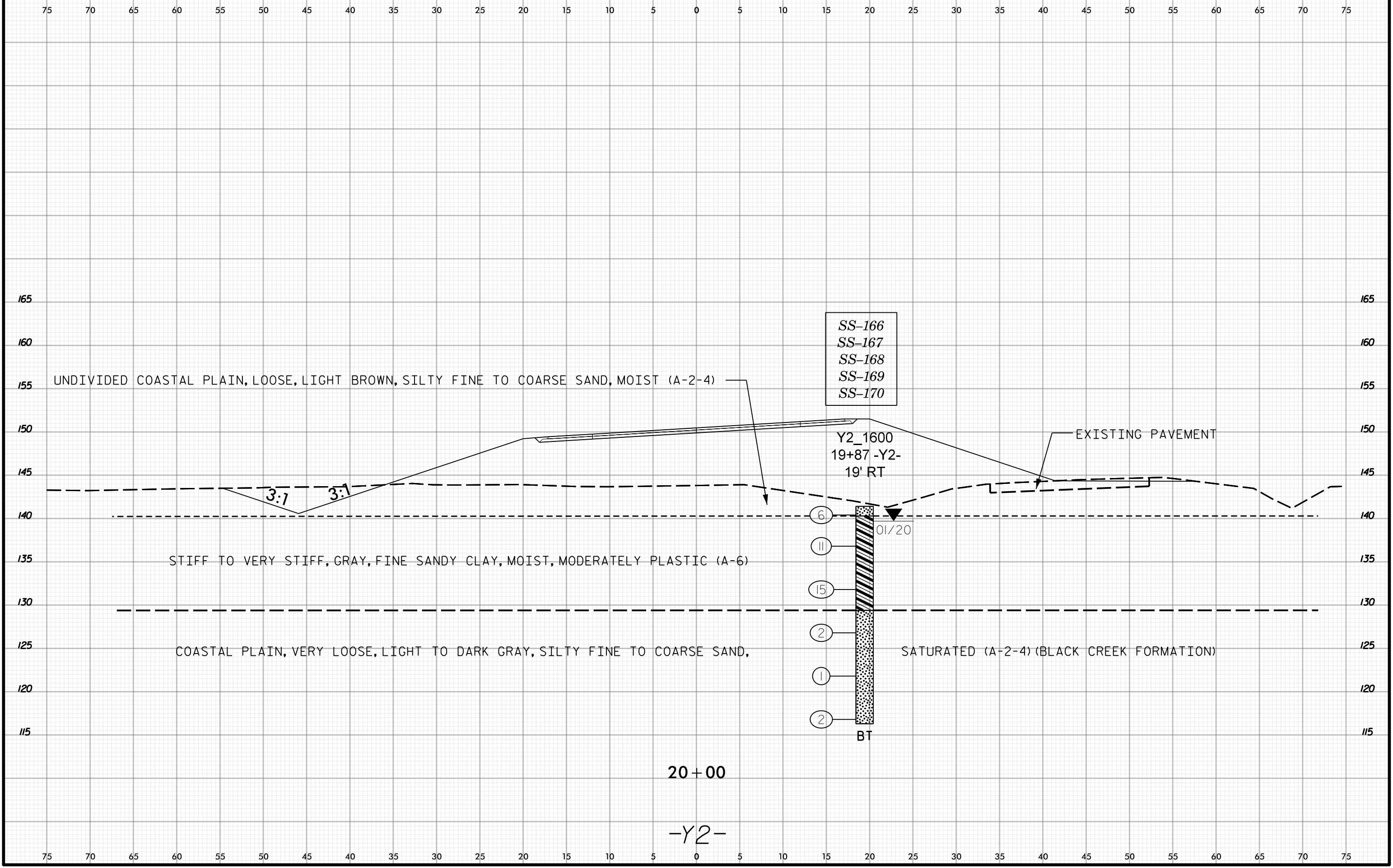
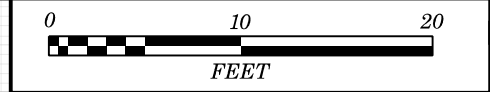

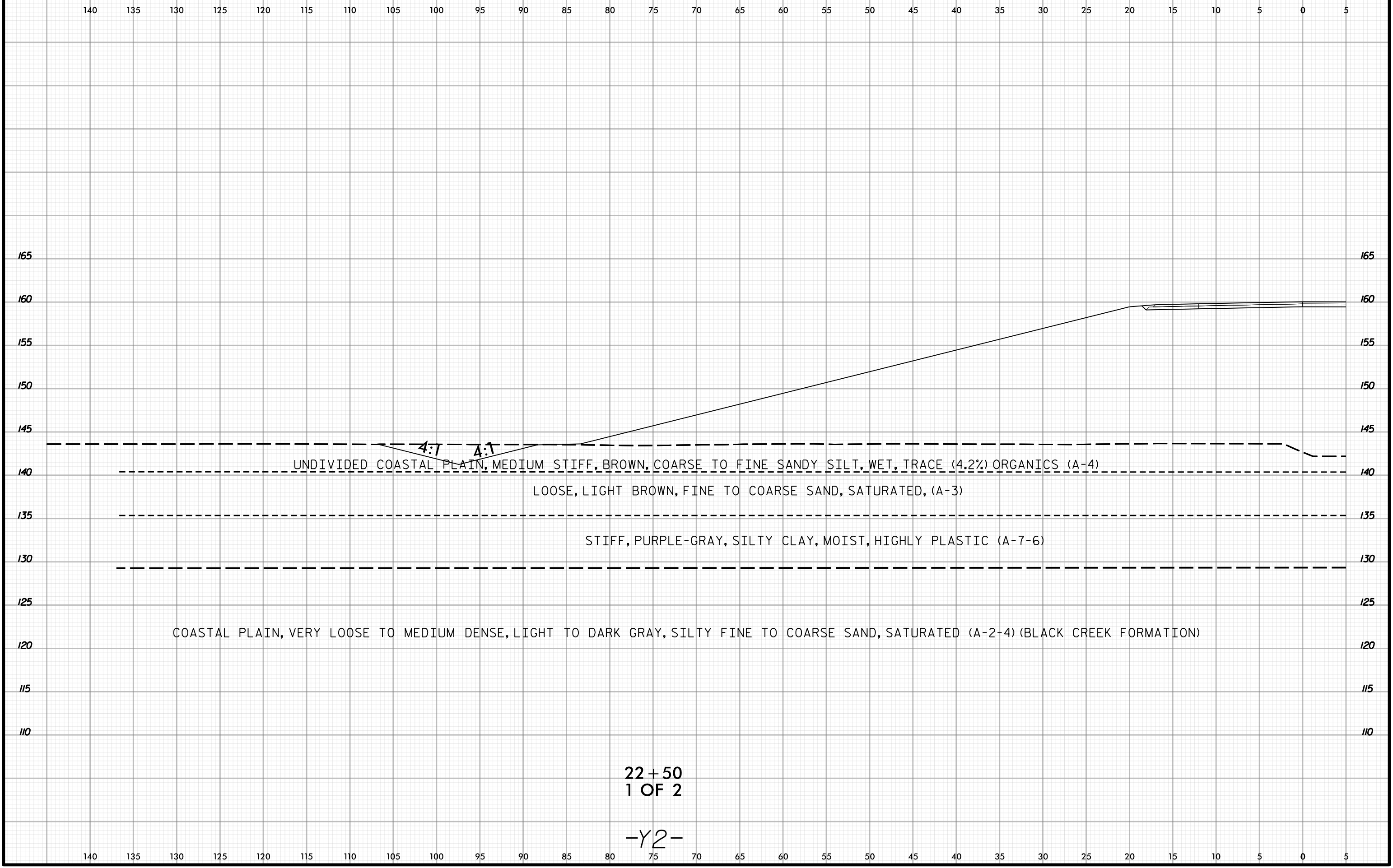
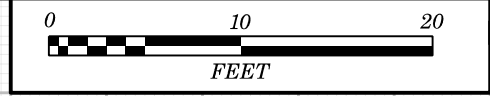

22+50
1 OF 2

-Y2-

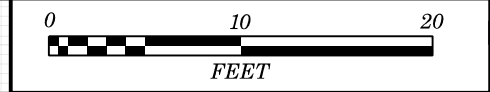

5 0 5 10 15 20 25 30 35 40 45 50 55 60 65 70 75 80 85 90 95 100 105 110 115 120 125 130 135 140 145

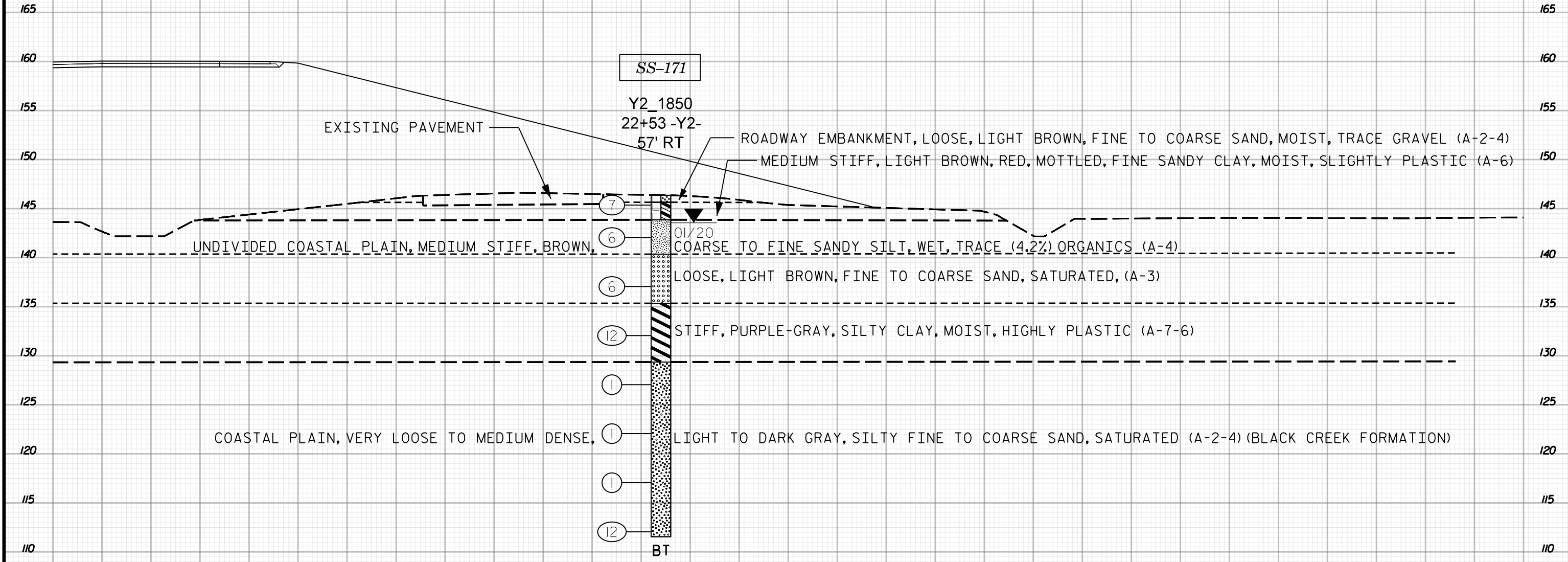

165
160
155
150
145
140
135
130
125
120
115
110

165
160
155
150
145
140
135
130
125
120
115
110

22+50
2 OF 2

-Y2-

5 0 5 10 15 20 25 30 35 40 45 50 55 60 65 70 75 80 85 90 95 100 105 110 115 120 125 130 135 140 145

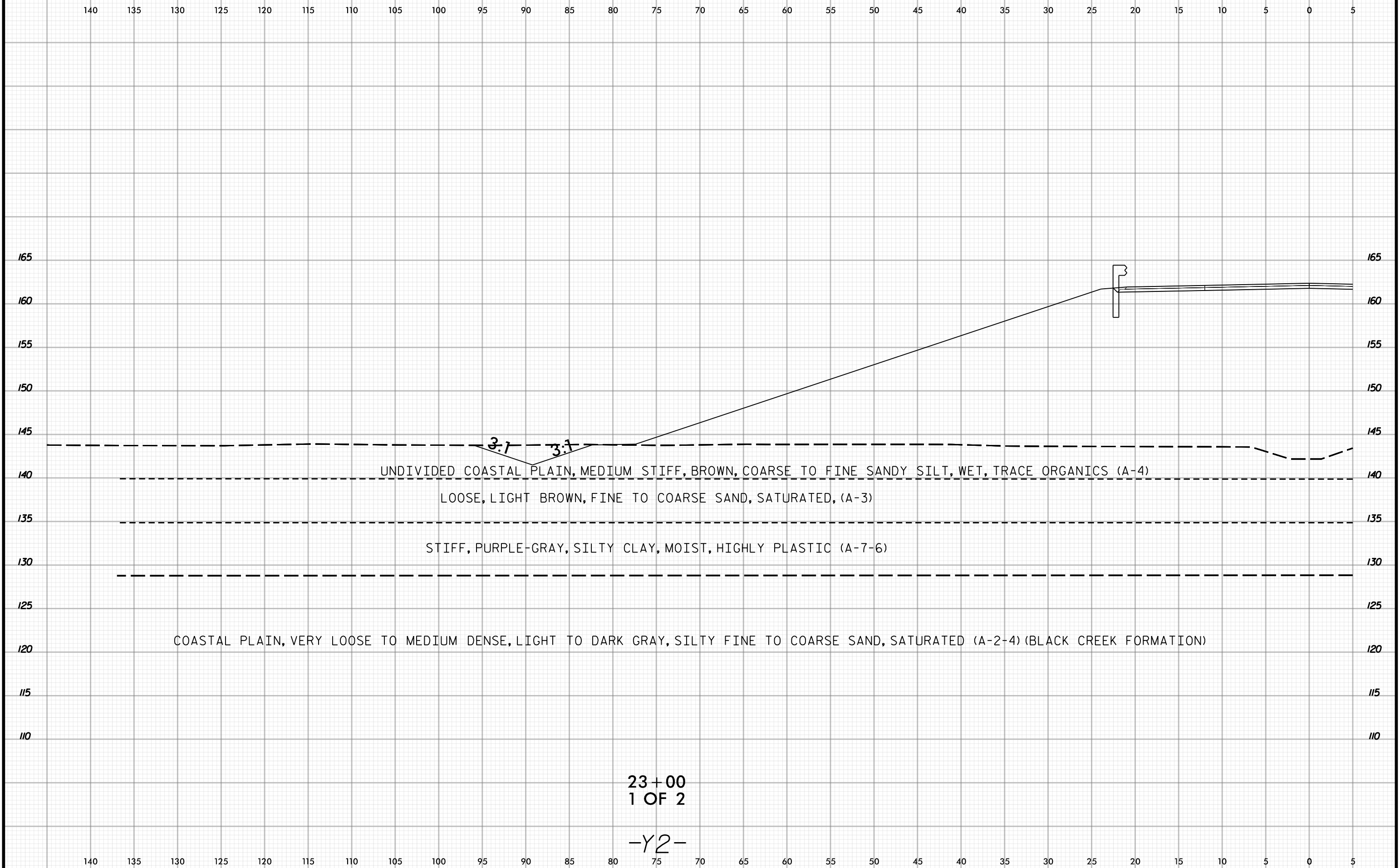

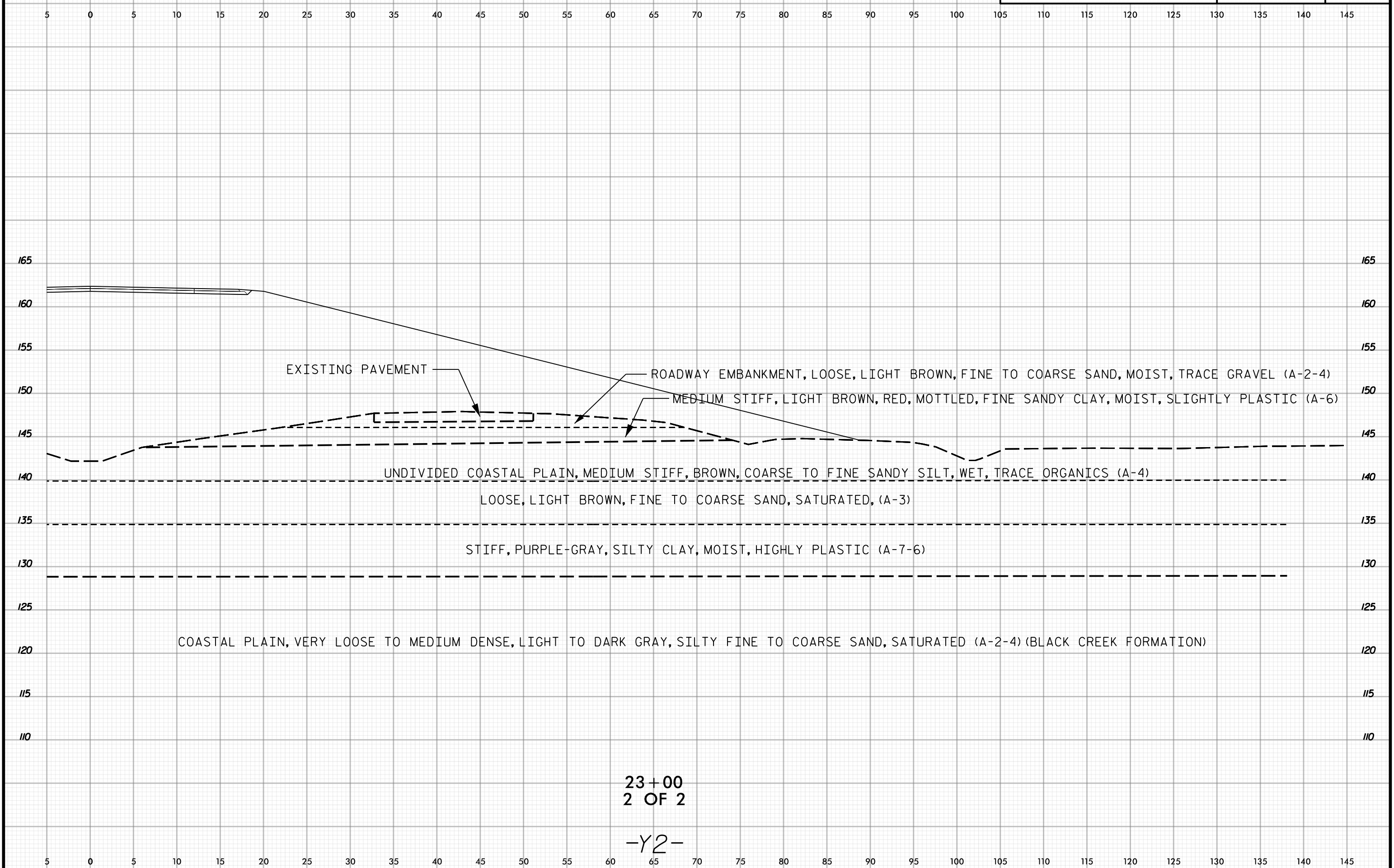

23+00
2 OF 2

-Y2-

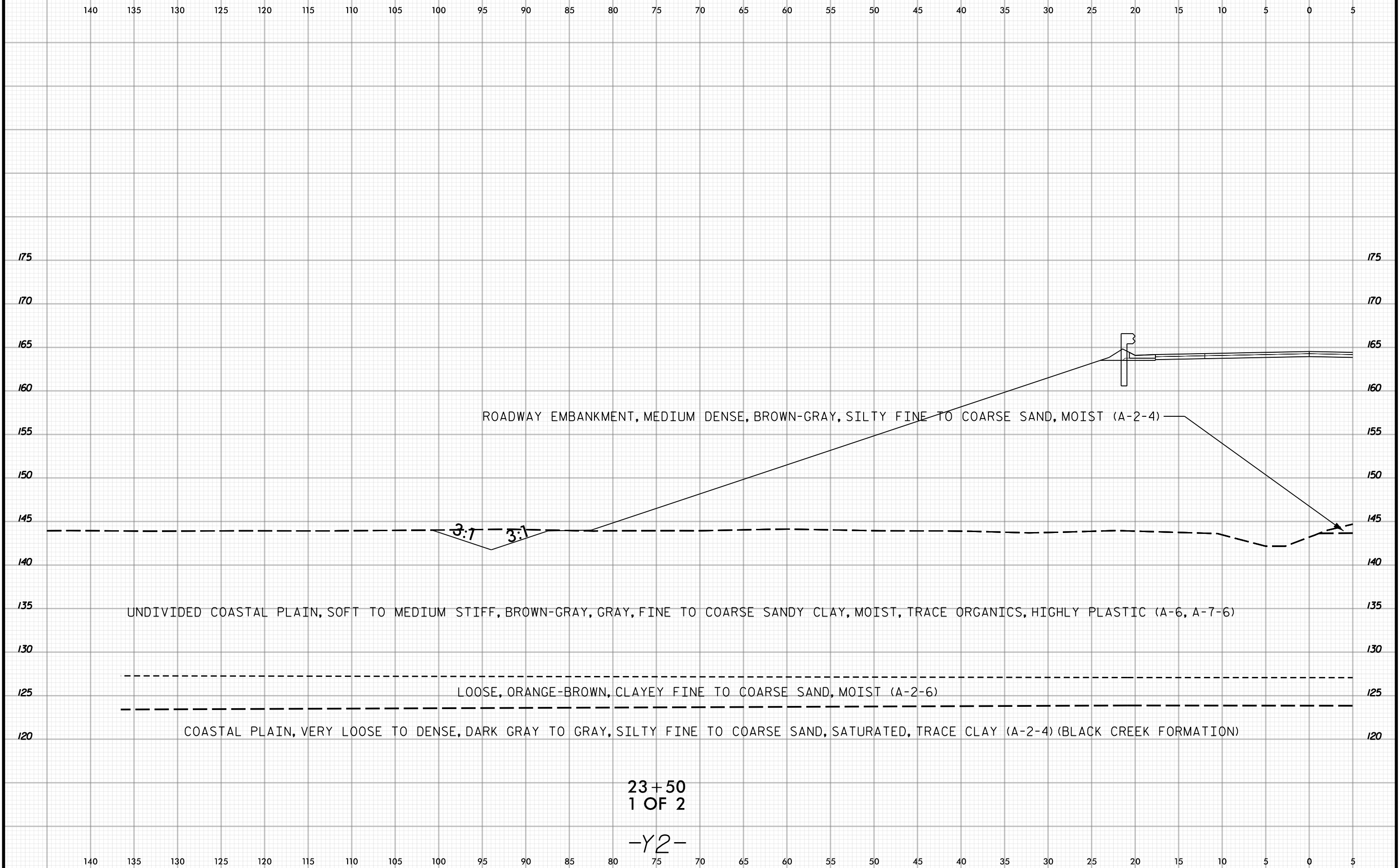

ROADWAY EMBANKMENT, MEDIUM DENSE, BROWN-GRAY, SILTY FINE TO COARSE SAND, MOIST (A-2-4)

UNDIVIDED COASTAL PLAIN, SOFT TO MEDIUM STIFF, BROWN-GRAY, GRAY, FINE TO COARSE SANDY CLAY, MOIST, TRACE ORGANICS, HIGHLY PLASTIC (A-6, A-7-6)

LOOSE, ORANGE-BROWN, CLAYEY FINE TO COARSE SAND, MOIST (A-2-6)

COASTAL PLAIN, VERY LOOSE TO DENSE, DARK GRAY TO GRAY, SILTY FINE TO COARSE SAND, SATURATED, TRACE CLAY (A-2-4) (BLACK CREEK FORMATION)

23+50
1 OF 2

-Y2-

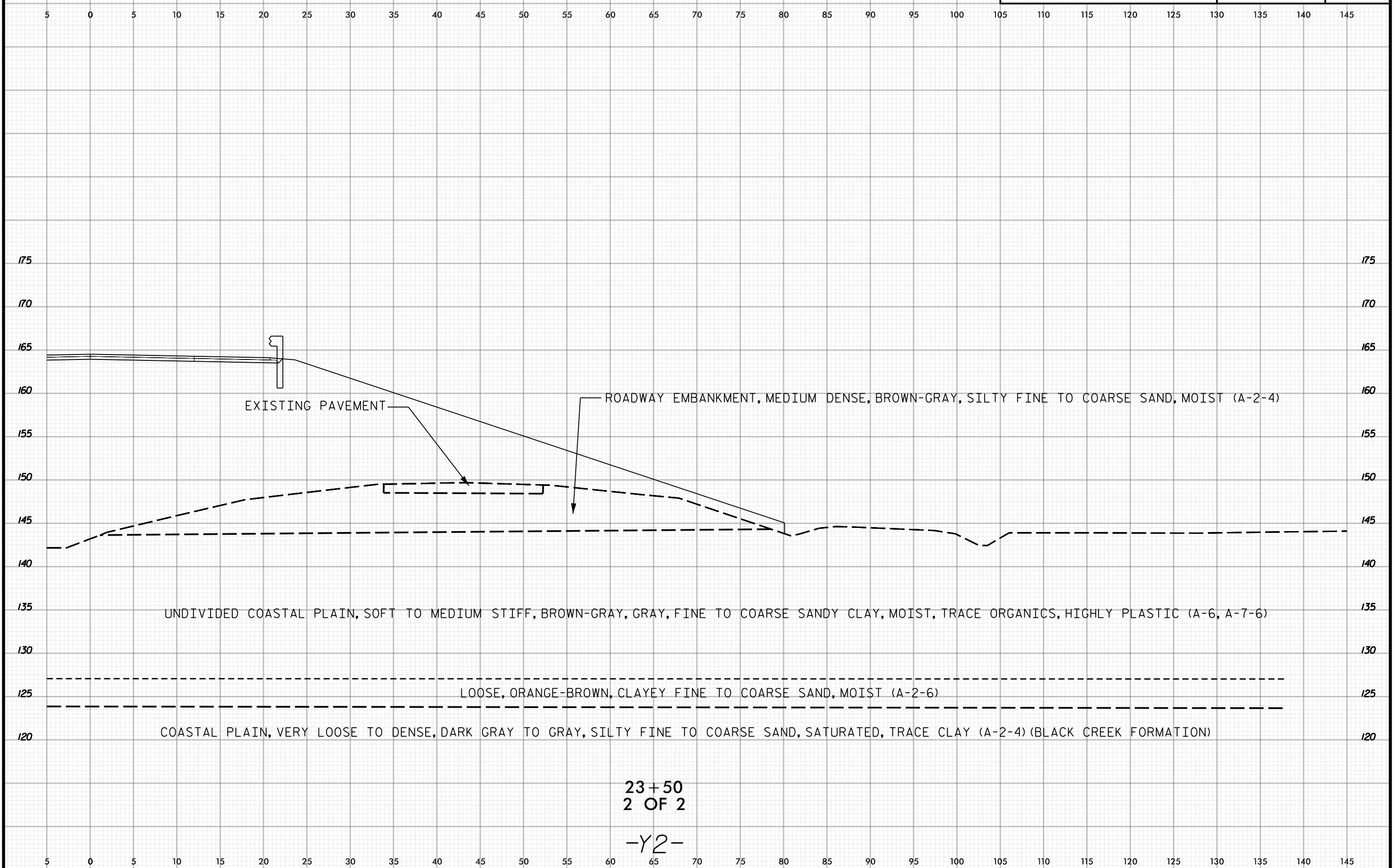

23+50
2 OF 2

-Y2-

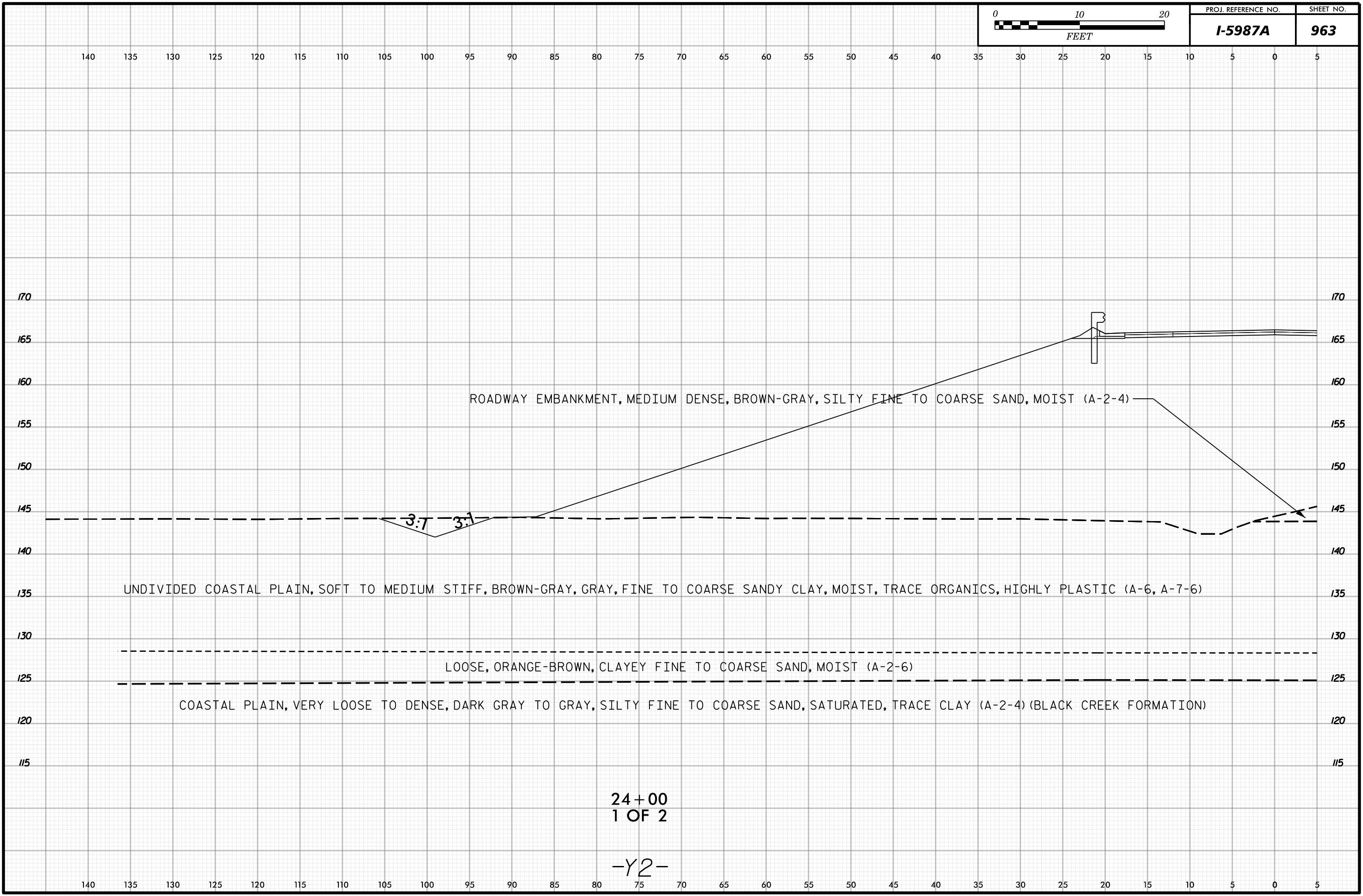



5 0 5 10 15 20 25 30 35 40 45 50 55 60 65 70 75 80 85 90 95 100 105 110 115 120 125 130 135 140 145

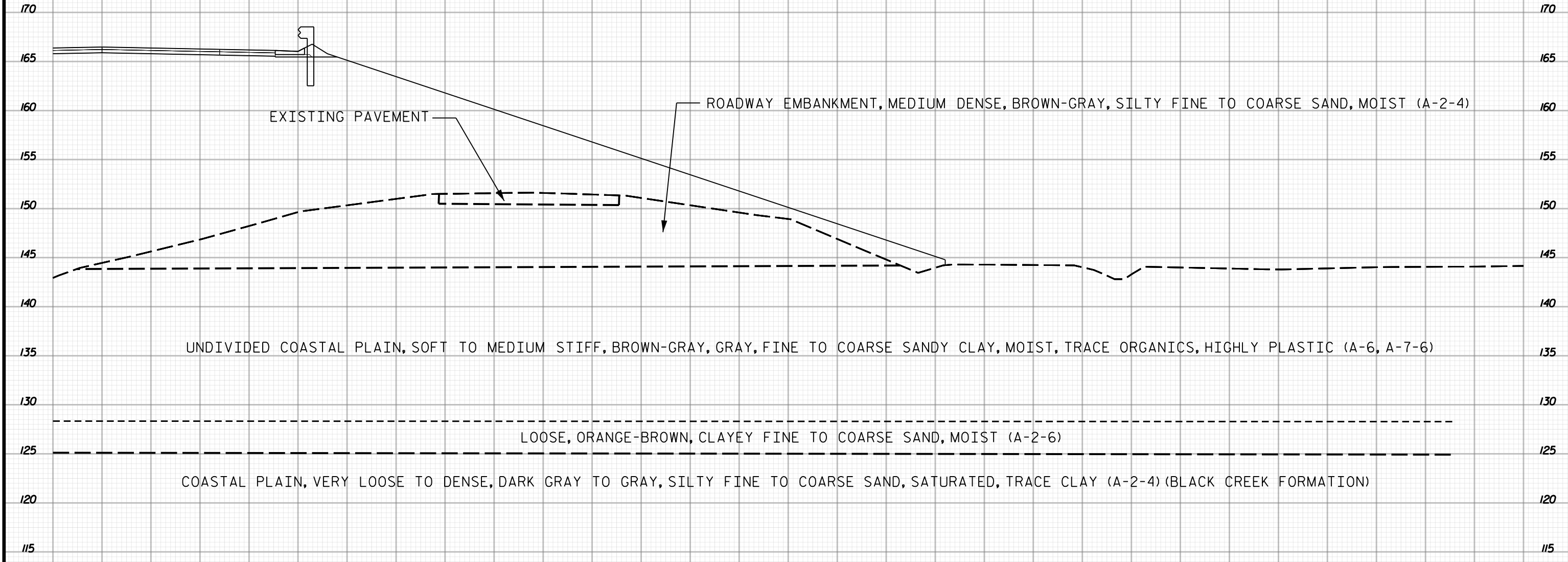

24+00
2 OF 2

-Y2-

5 0 5 10 15 20 25 30 35 40 45 50 55 60 65 70 75 80 85 90 95 100 105 110 115 120 125 130 135 140 145

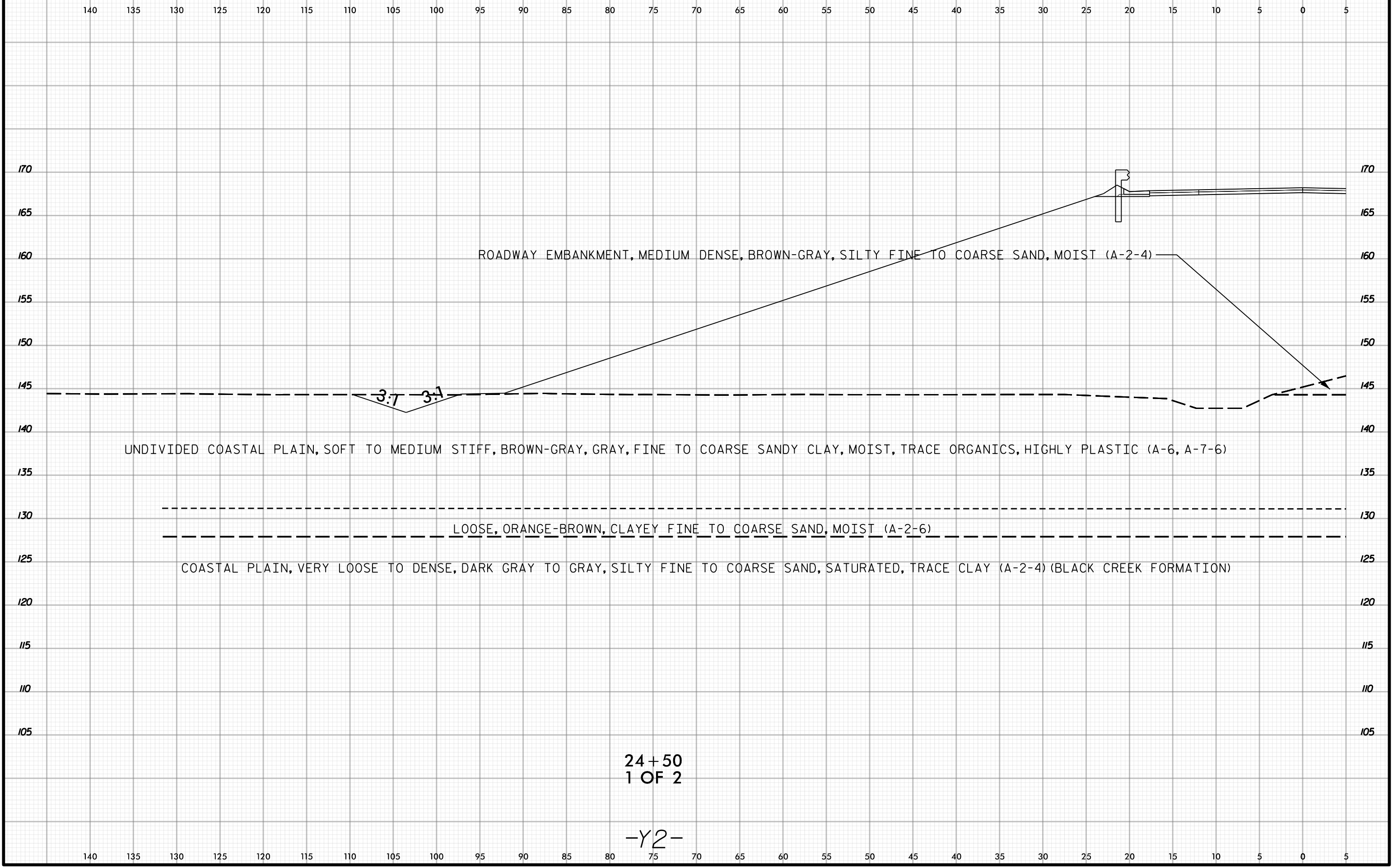

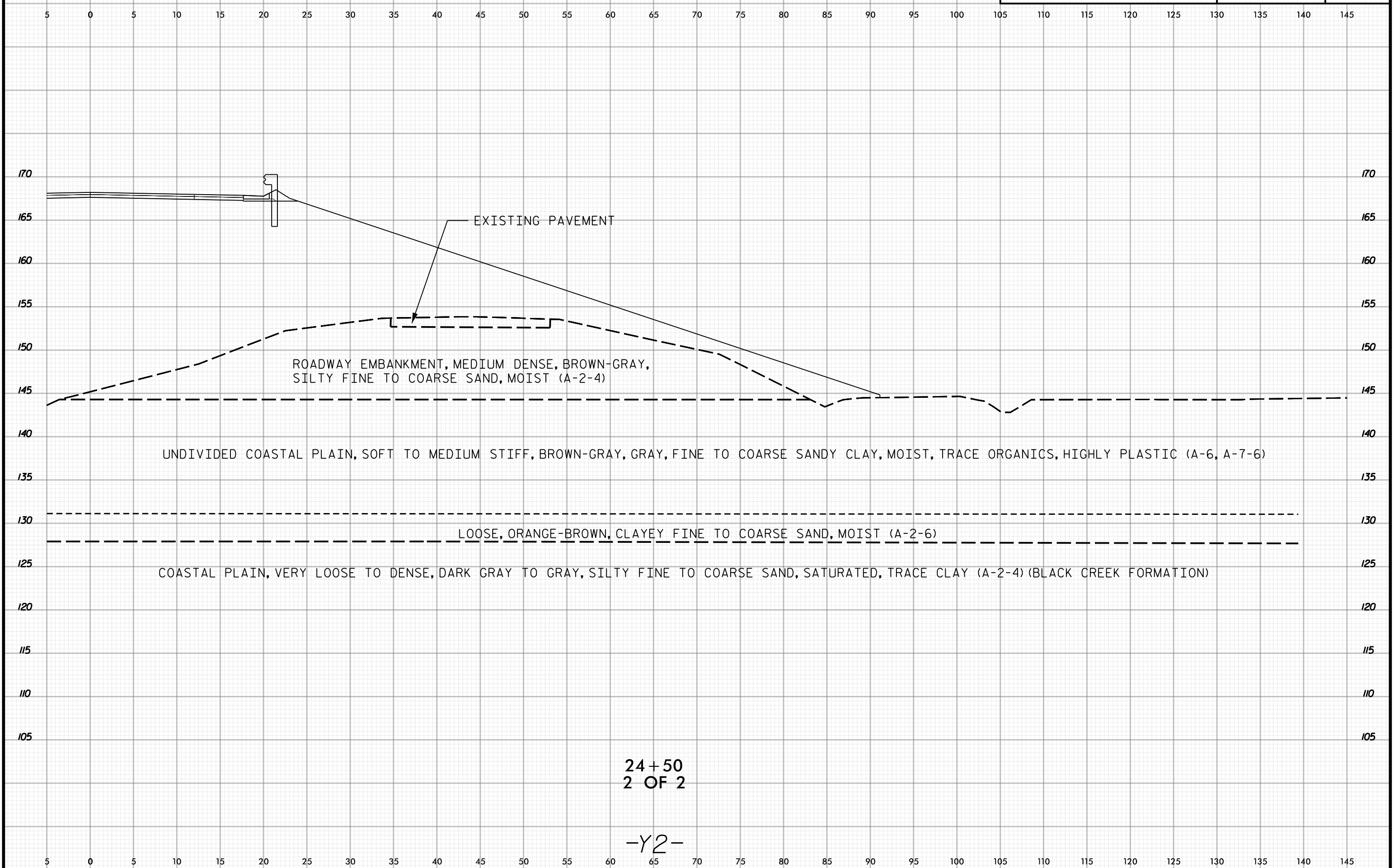

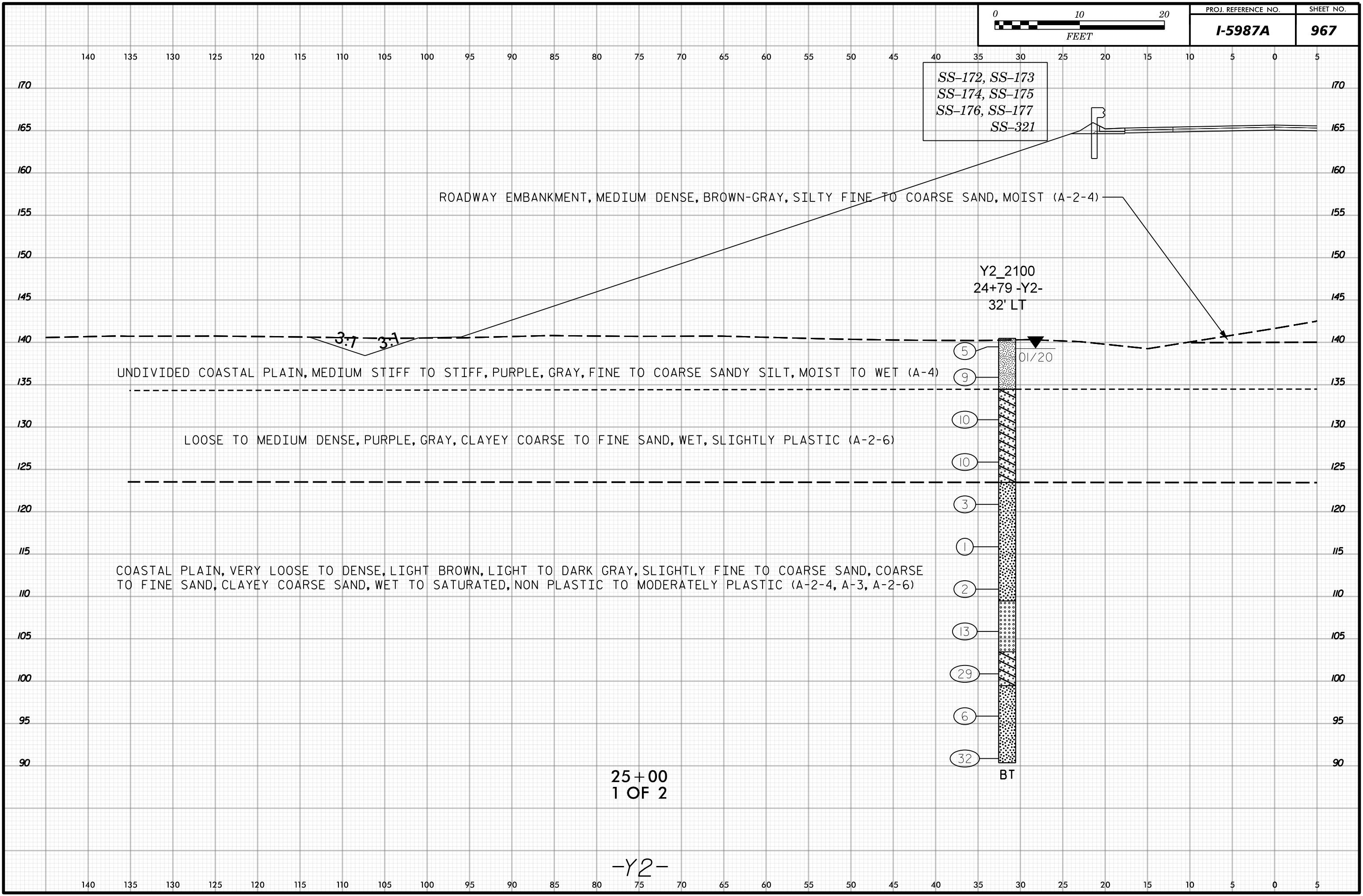
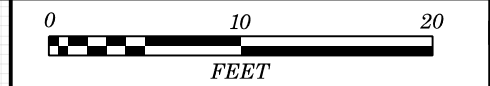

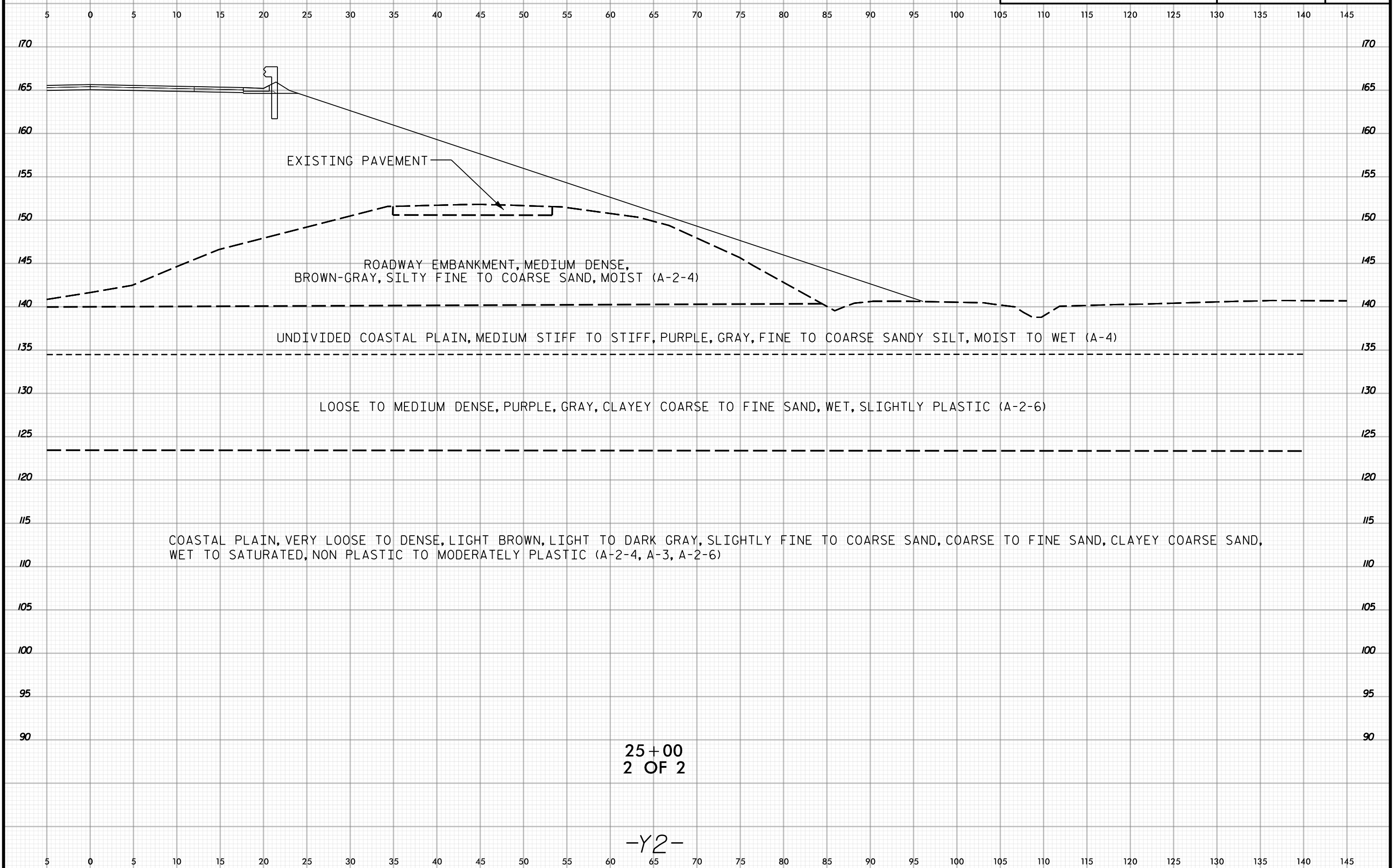

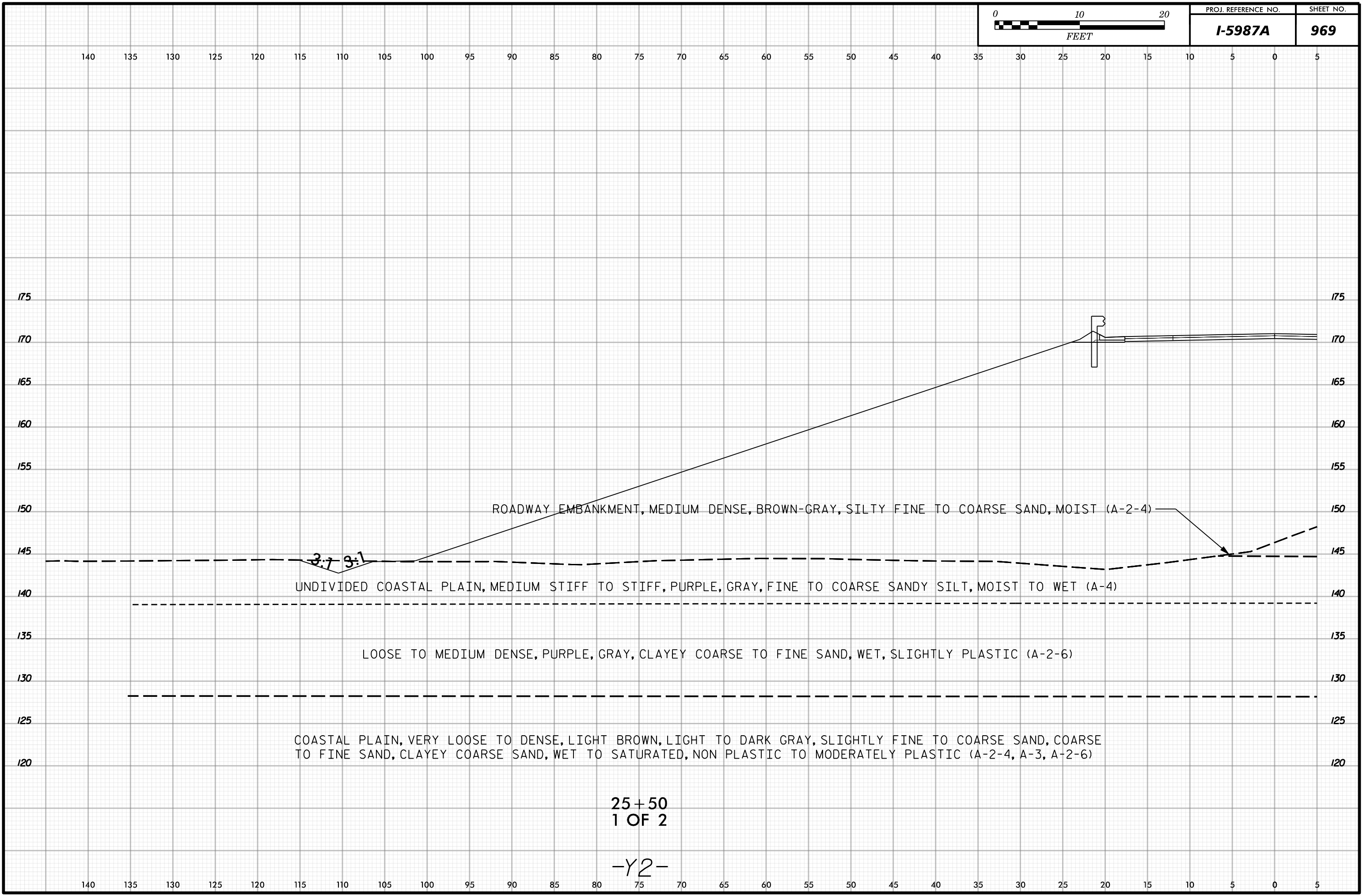

ROADWAY EMBANKMENT, MEDIUM DENSE, BROWN-GRAY, SILTY FINE TO COARSE SAND, MOIST (A-2-4)

UNDIVIDED COASTAL PLAIN, MEDIUM STIFF TO STIFF, PURPLE, GRAY, FINE TO COARSE SANDY SILT, MOIST TO WET (A-4)

LOOSE TO MEDIUM DENSE, PURPLE, GRAY, CLAYEY COARSE TO FINE SAND, WET, SLIGHTLY PLASTIC (A-2-6)

COASTAL PLAIN, VERY LOOSE TO DENSE, LIGHT BROWN, LIGHT TO DARK GRAY, SLIGHTLY FINE TO COARSE SAND, COARSE TO FINE SAND, CLAYEY COARSE SAND, WET TO SATURATED, NON PLASTIC TO MODERATELY PLASTIC (A-2-4, A-3, A-2-6)

25+50
1 OF 2

-Y2-

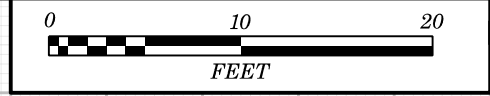

PROJ. REFERENCE NO.	SHEET NO.
I-5987A	970

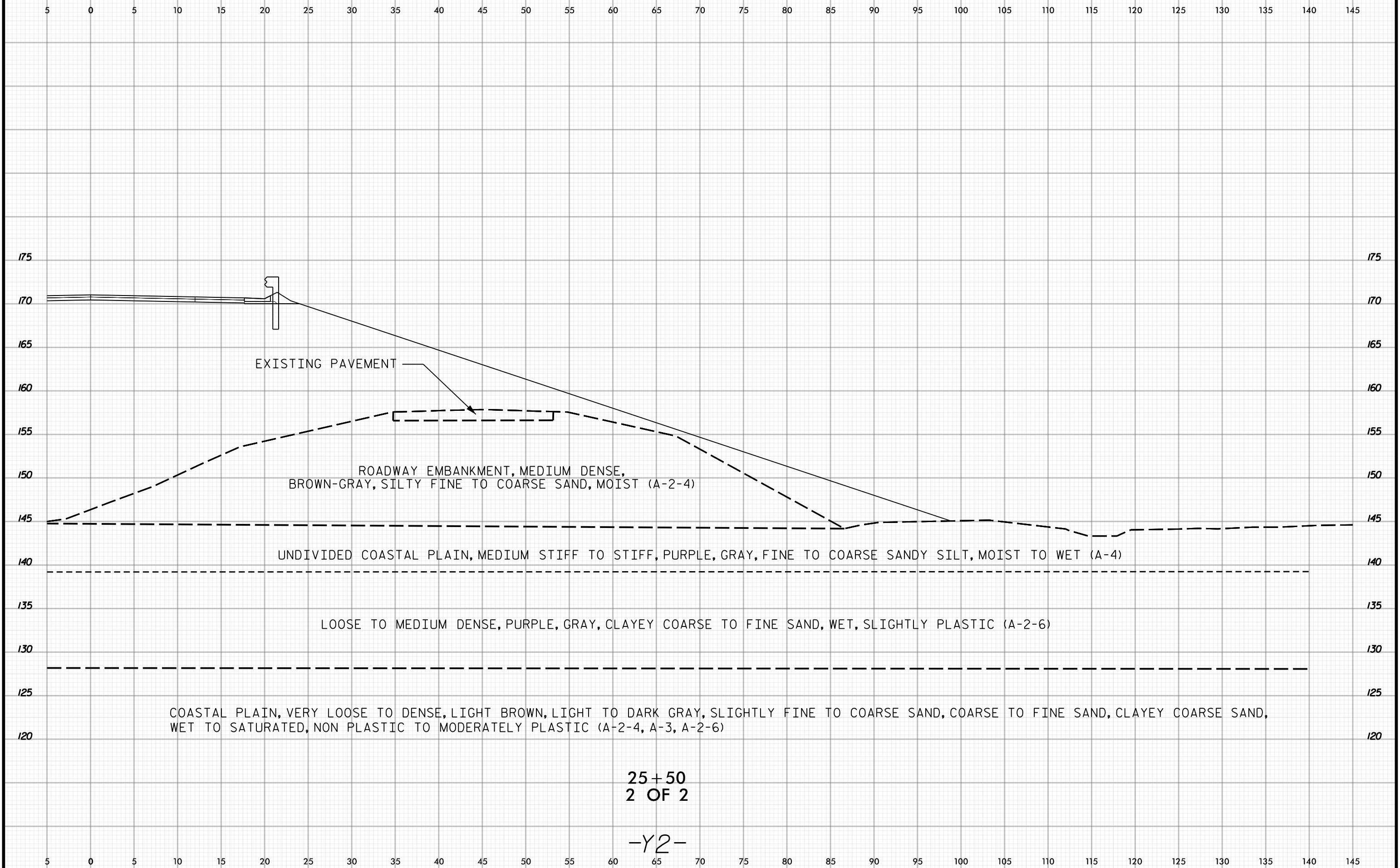

25+50
2 OF 2

-Y2-

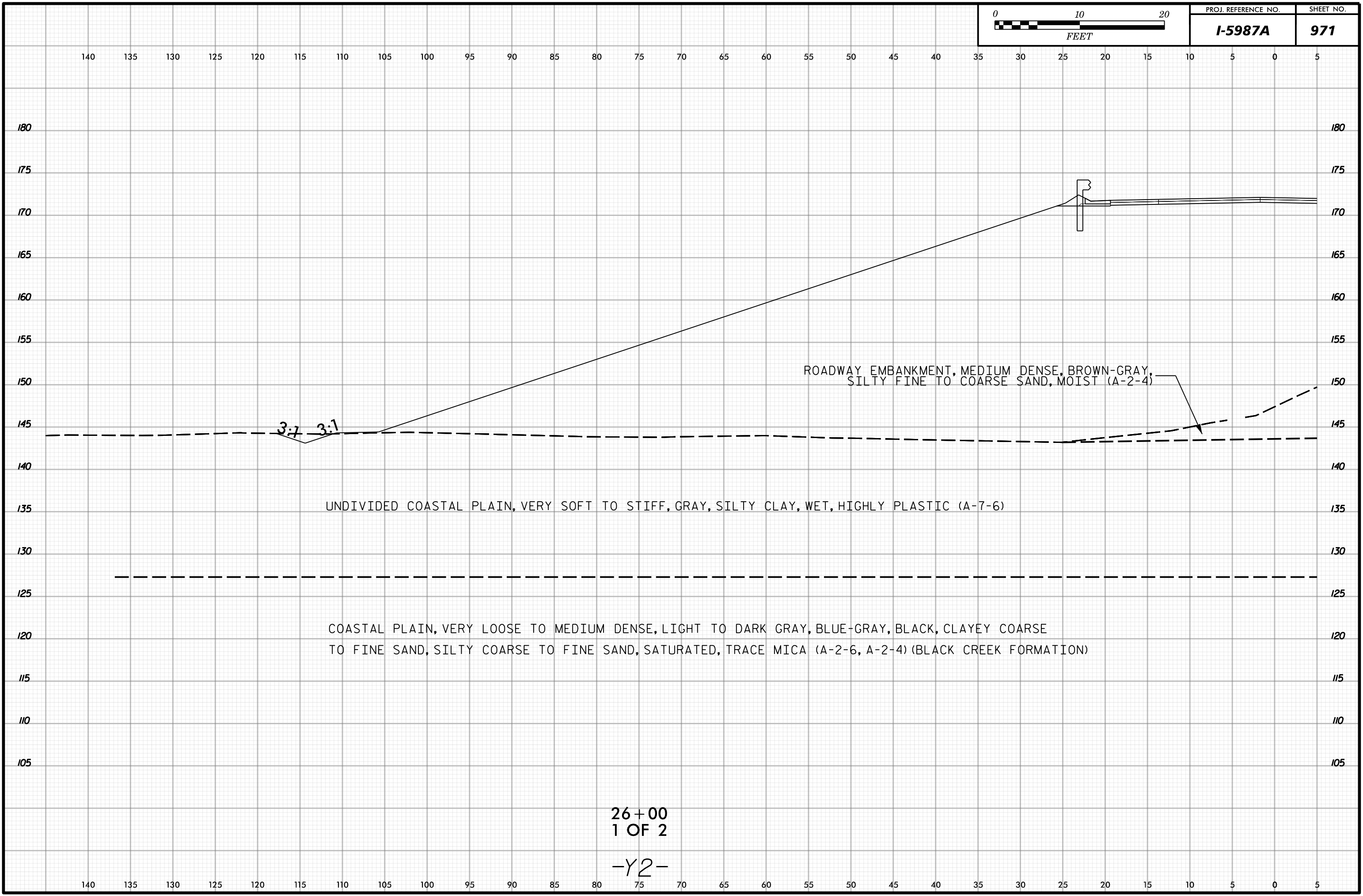

ROADWAY EMBANKMENT, MEDIUM DENSE, BROWN-GRAY,
SILTY FINE TO COARSE SAND, MOIST (A-2-4)

UNDIVIDED COASTAL PLAIN, VERY SOFT TO STIFF, GRAY, SILTY CLAY, WET, HIGHLY PLASTIC (A-7-6)

COASTAL PLAIN, VERY LOOSE TO MEDIUM DENSE, LIGHT TO DARK GRAY, BLUE-GRAY, BLACK, CLAYEY COARSE
TO FINE SAND, SILTY COARSE TO FINE SAND, SATURATED, TRACE MICA (A-2-6, A-2-4) (BLACK CREEK FORMATION)

3:7 3:1

26+00
1 OF 2

-Y2-

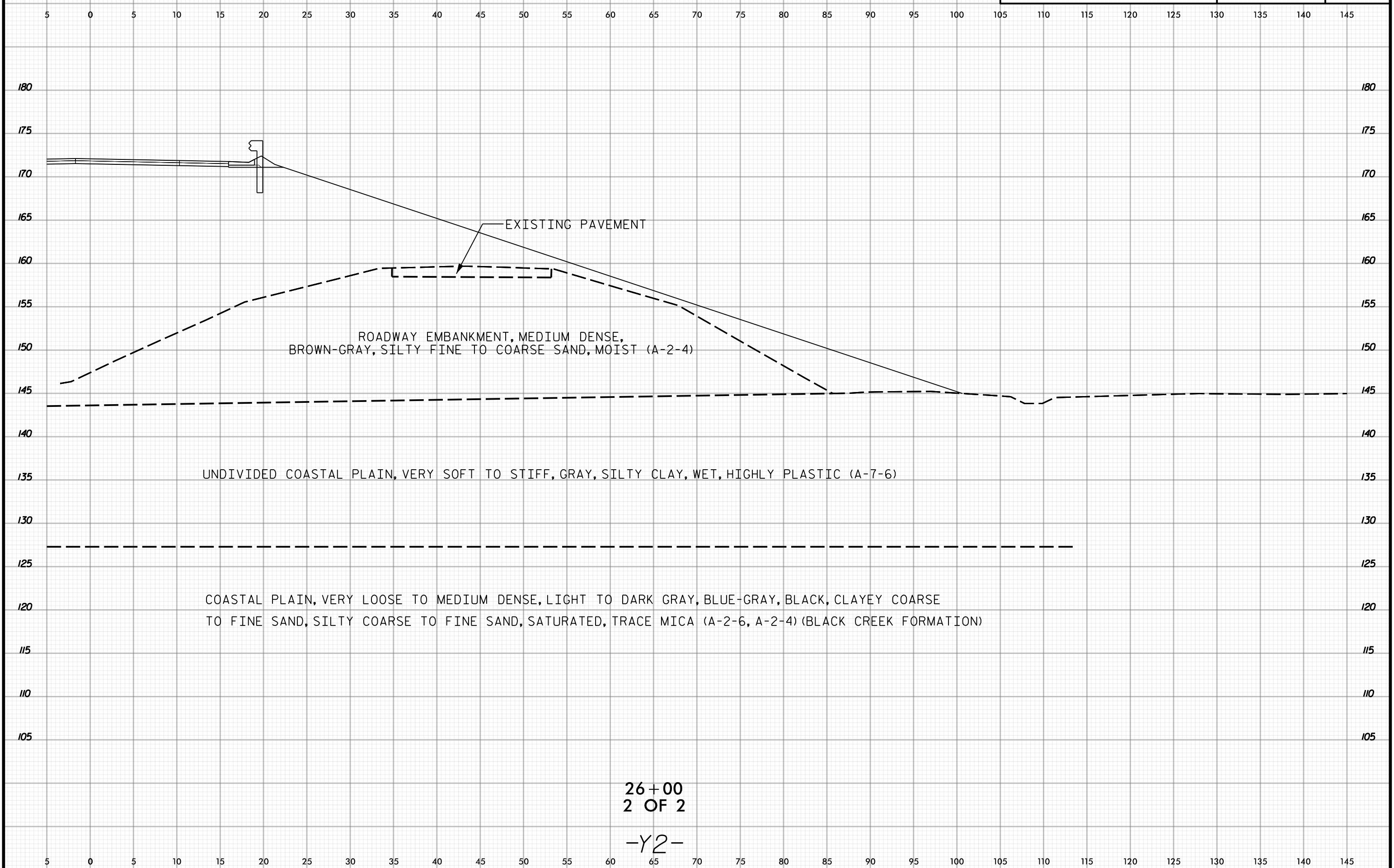

EXISTING PAVEMENT

ROADWAY EMBANKMENT, MEDIUM DENSE,
BROWN-GRAY, SILTY FINE TO COARSE SAND, MOIST (A-2-4)

UNDIVIDED COASTAL PLAIN, VERY SOFT TO STIFF, GRAY, SILTY CLAY, WET, HIGHLY PLASTIC (A-7-6)

COASTAL PLAIN, VERY LOOSE TO MEDIUM DENSE, LIGHT TO DARK GRAY, BLUE-GRAY, BLACK, CLAYEY COARSE
TO FINE SAND, SILTY COARSE TO FINE SAND, SATURATED, TRACE MICA (A-2-6, A-2-4) (BLACK CREEK FORMATION)

26+00
2 OF 2

-Y2-

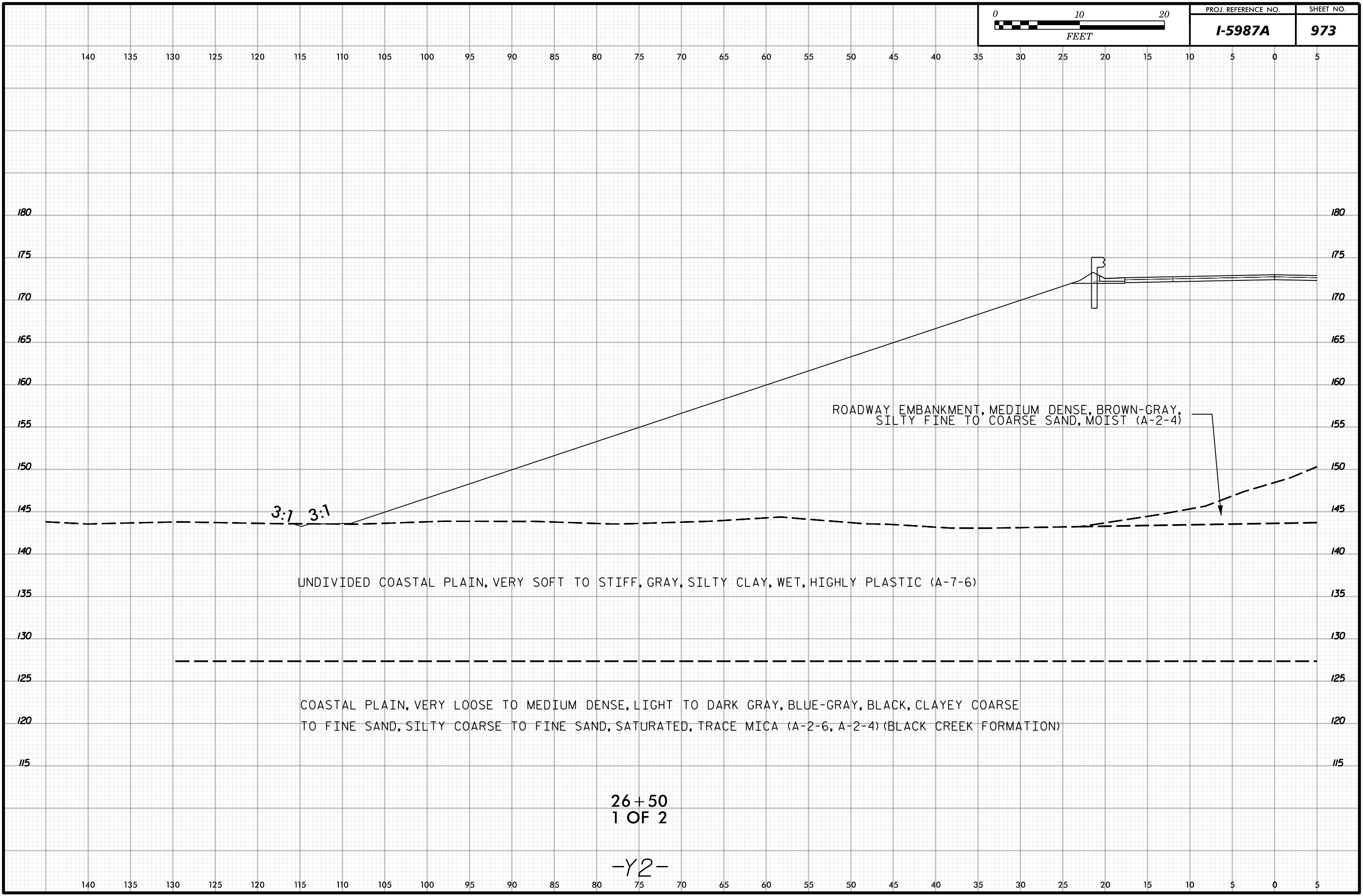

26+50
1 OF 2

-Y2-

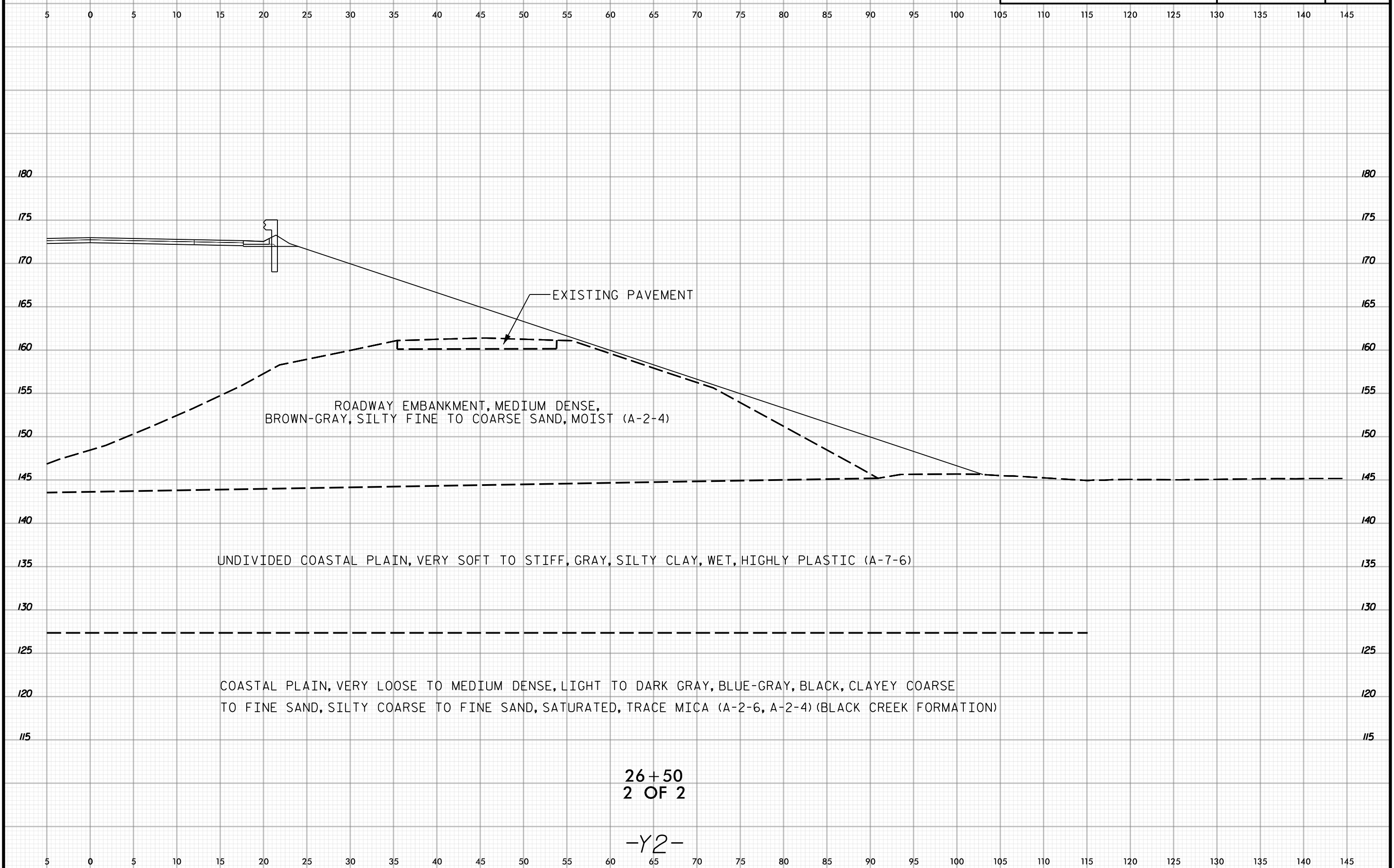

26+50
2 OF 2

-Y2-

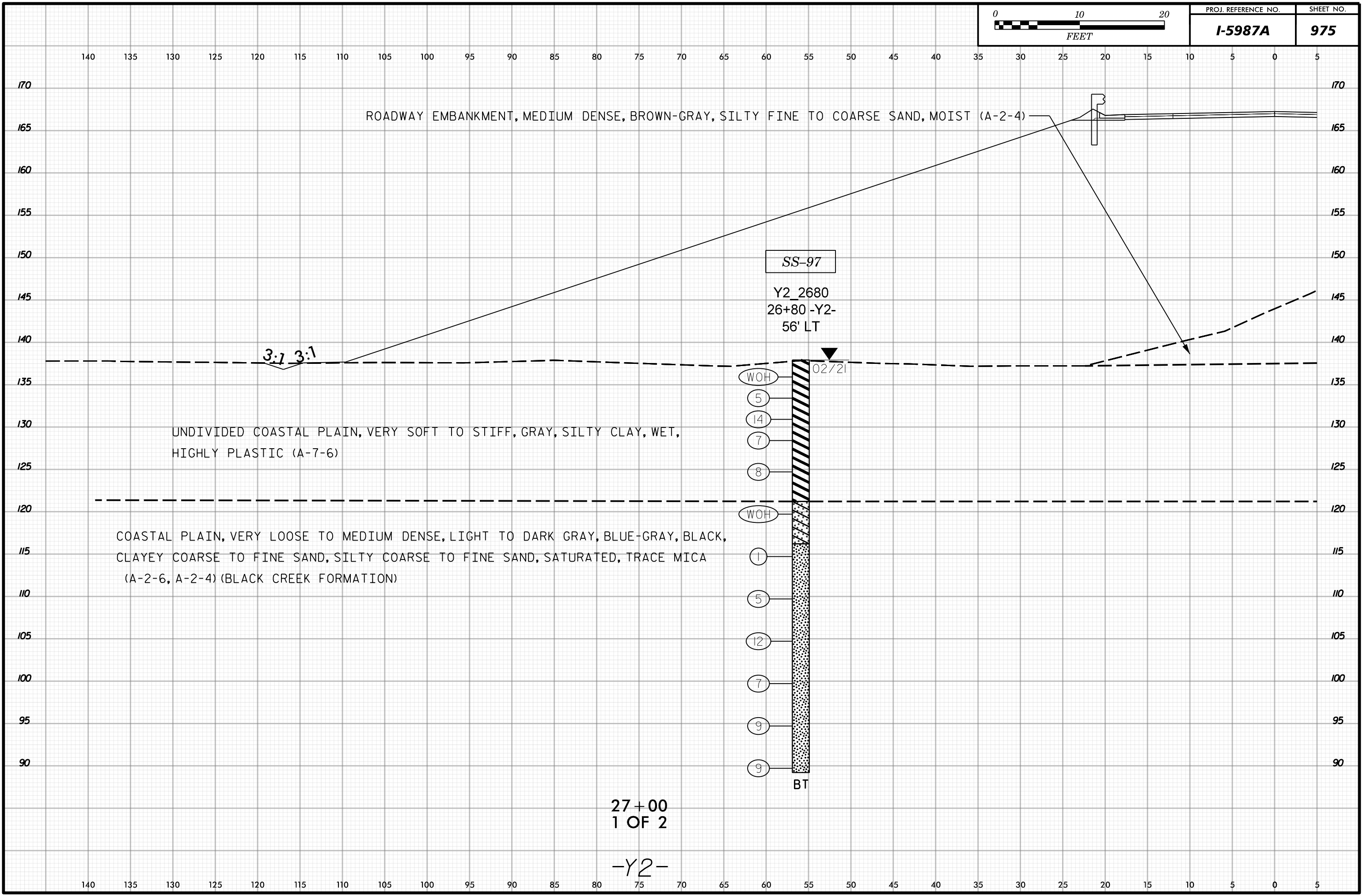
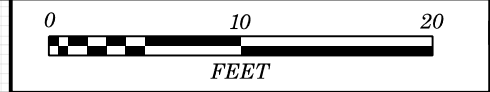

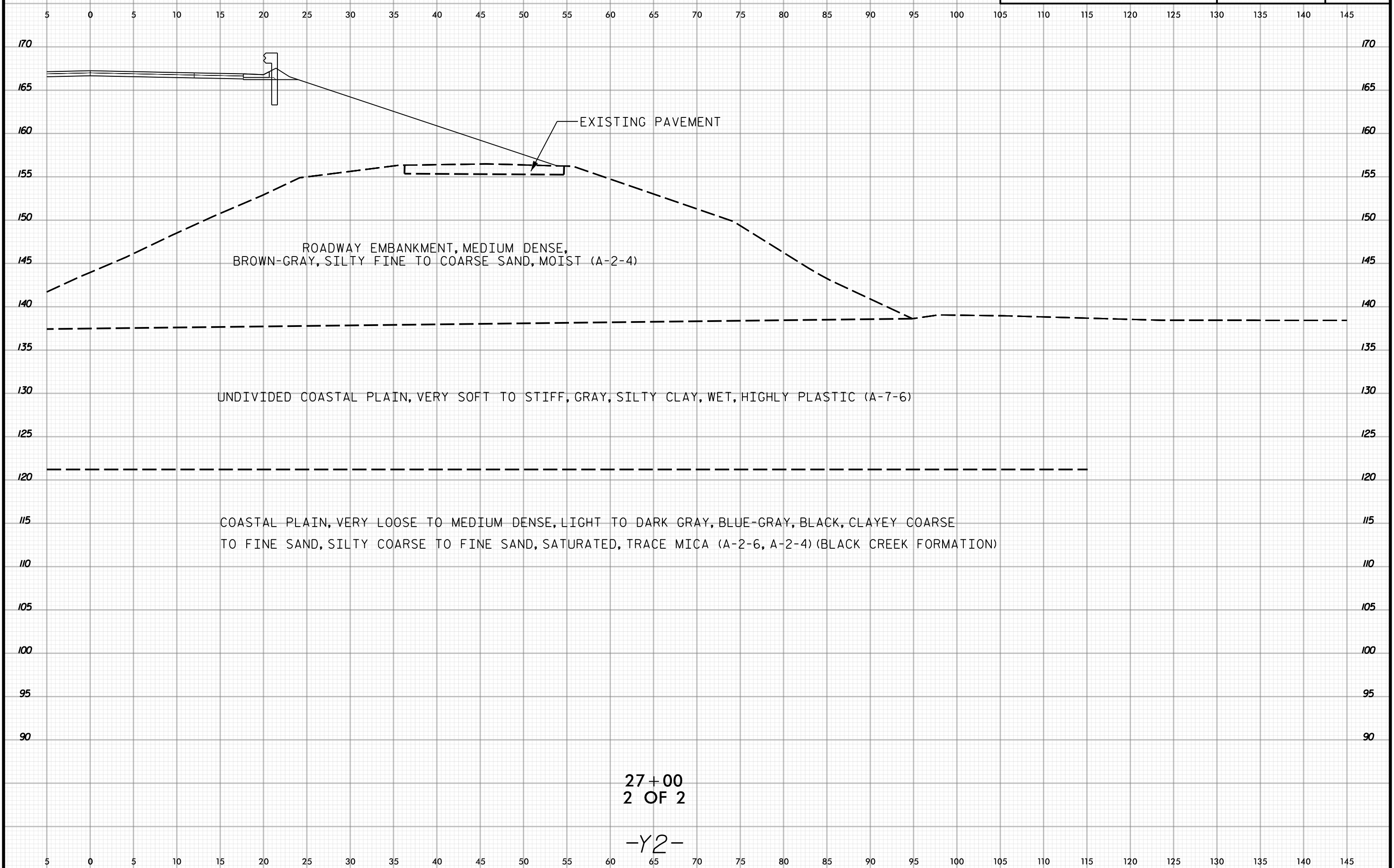

27+00
2 OF 2

-Y2-

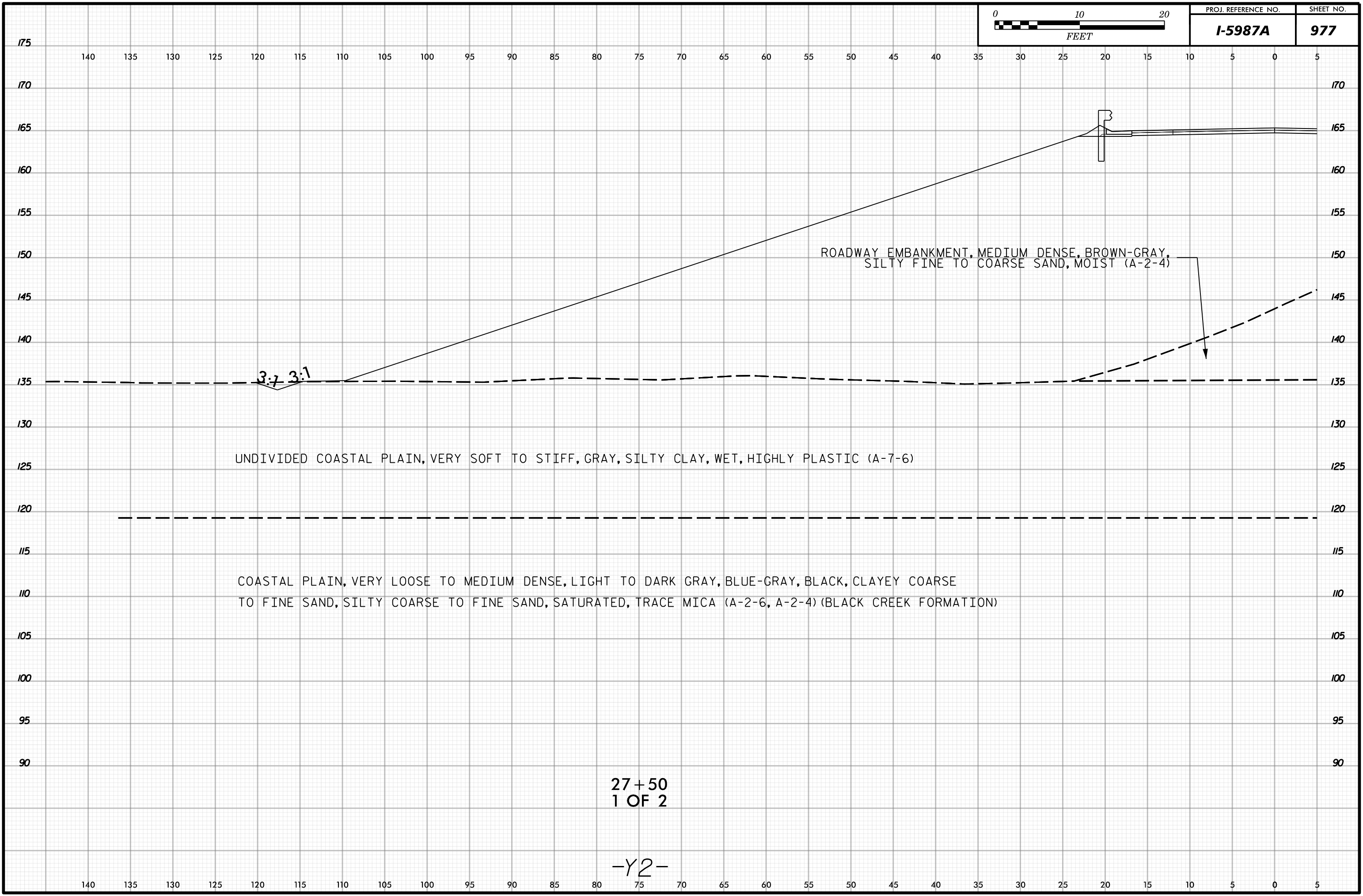

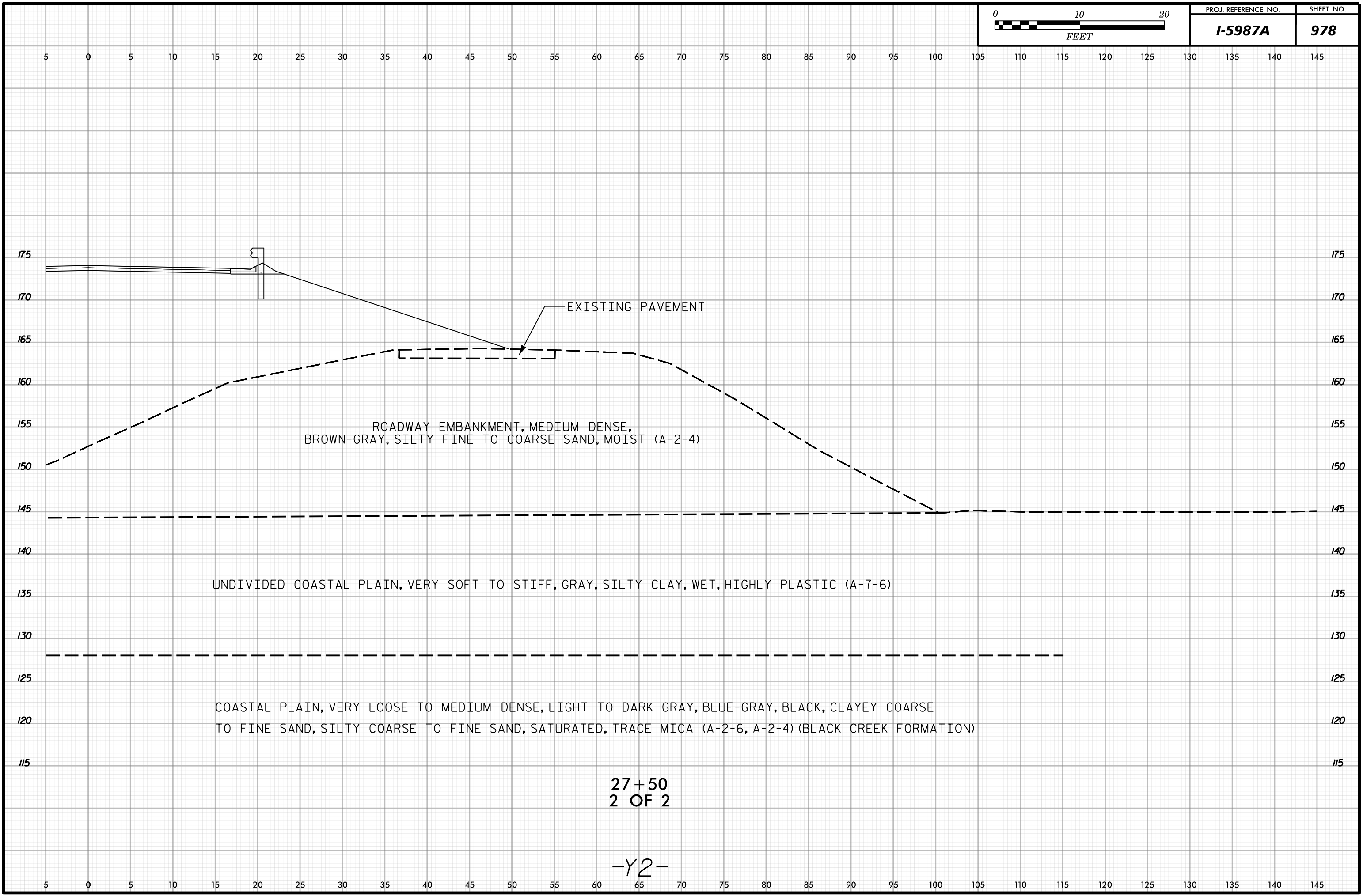

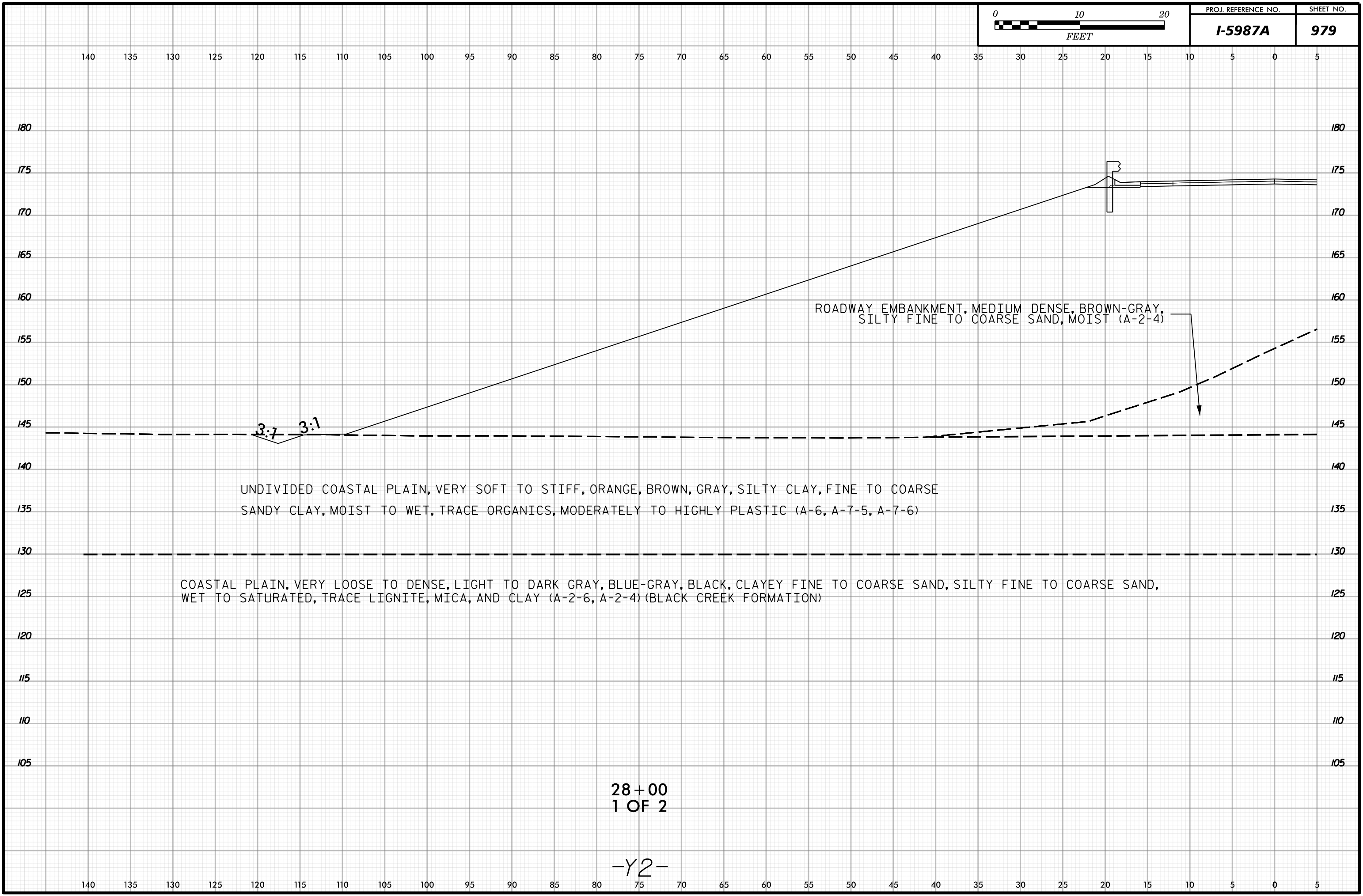

UNDIVIDED COASTAL PLAIN, VERY SOFT TO STIFF, ORANGE, BROWN, GRAY, SILTY CLAY, FINE TO COARSE SANDY CLAY, MOIST TO WET, TRACE ORGANICS, MODERATELY TO HIGHLY PLASTIC (A-6, A-7-5, A-7-6)

COASTAL PLAIN, VERY LOOSE TO DENSE, LIGHT TO DARK GRAY, BLUE-GRAY, BLACK, CLAYEY FINE TO COARSE SAND, SILTY FINE TO COARSE SAND, WET TO SATURATED, TRACE LIGNITE, MICA, AND CLAY (A-2-6, A-2-4) (BLACK CREEK FORMATION)

ROADWAY EMBANKMENT, MEDIUM DENSE, BROWN-GRAY, SILTY FINE TO COARSE SAND, MOIST (A-2-4)

28+00
1 OF 2

-Y2-



5 0 5 10 15 20 25 30 35 40 45 50 55 60 65 70 75 80 85 90 95 100 105 110 115 120 125 130 135 140 145

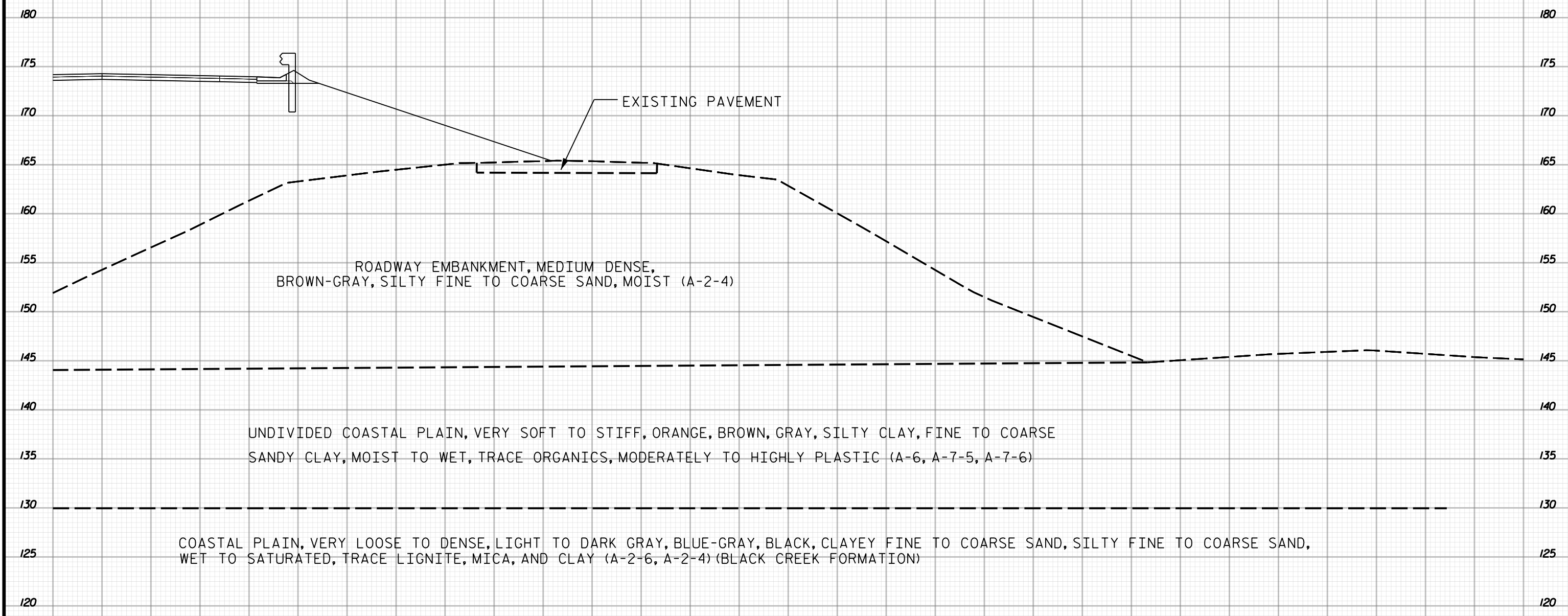

28+00
2 OF 2

-Y2-

5 0 5 10 15 20 25 30 35 40 45 50 55 60 65 70 75 80 85 90 95 100 105 110 115 120 125 130 135 140 145

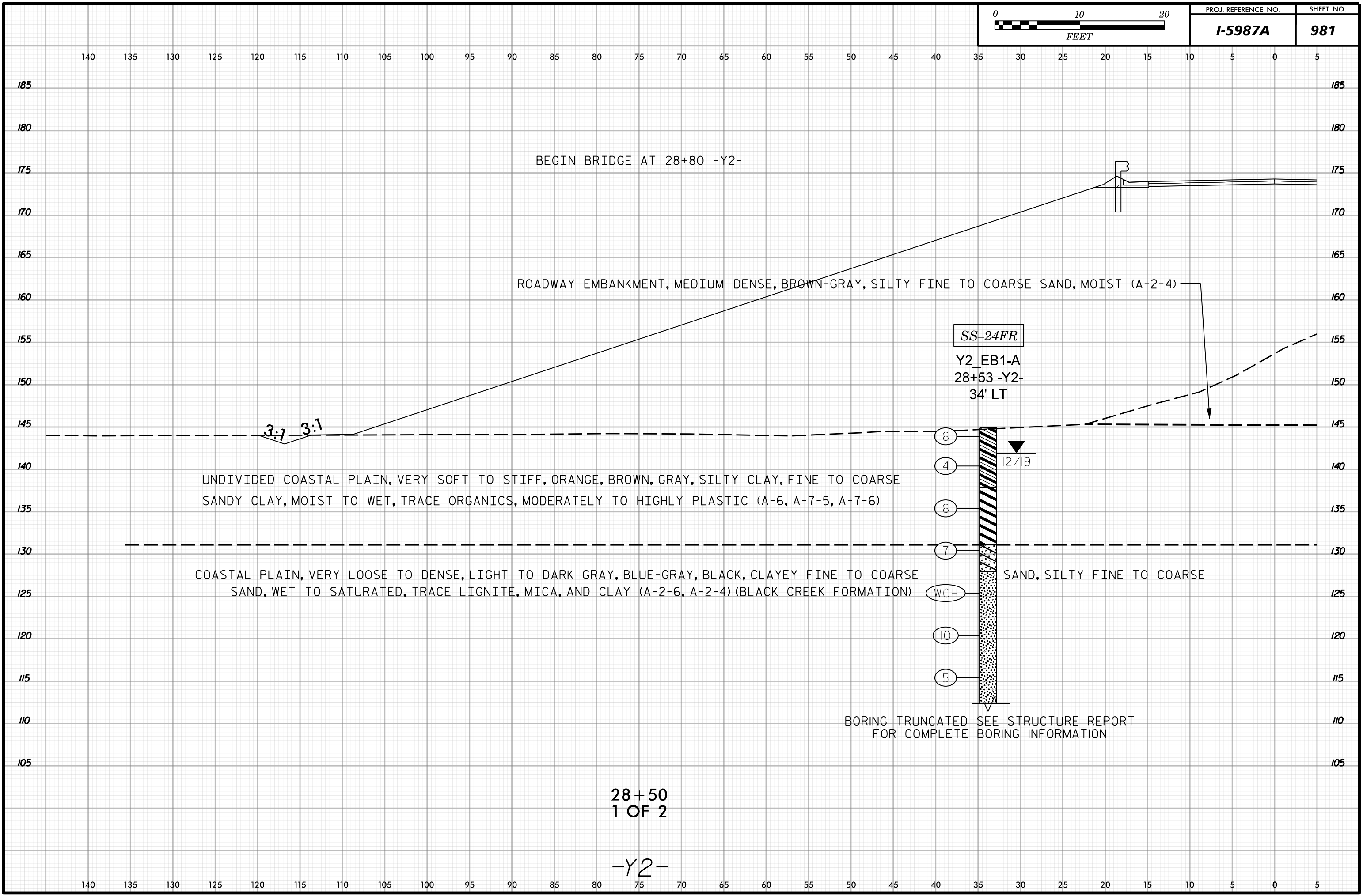
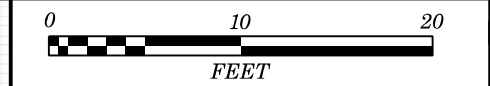

BEGIN BRIDGE AT 28+80 -Y2-

ROADWAY EMBANKMENT, MEDIUM DENSE, BROWN-GRAY, SILTY FINE TO COARSE SAND, MOIST (A-2-4)

SS-24FR

Y2_EB1-A
28+53 -Y2-
34' LT

3:1 3:1

UNDIVIDED COASTAL PLAIN, VERY SOFT TO STIFF, ORANGE, BROWN, GRAY, SILTY CLAY, FINE TO COARSE SANDY CLAY, MOIST TO WET, TRACE ORGANICS, MODERATELY TO HIGHLY PLASTIC (A-6, A-7-5, A-7-6)

COASTAL PLAIN, VERY LOOSE TO DENSE, LIGHT TO DARK GRAY, BLUE-GRAY, BLACK, CLAYEY FINE TO COARSE SAND, WET TO SATURATED, TRACE LIGNITE, MICA, AND CLAY (A-2-6, A-2-4) (BLACK CREEK FORMATION)

SAND, SILTY FINE TO COARSE

- 6
- 4
- 6
- 7
- WOH
- 10
- 5

127.19

BORING TRUNCATED SEE STRUCTURE REPORT FOR COMPLETE BORING INFORMATION

28+50
1 OF 2

-Y2-

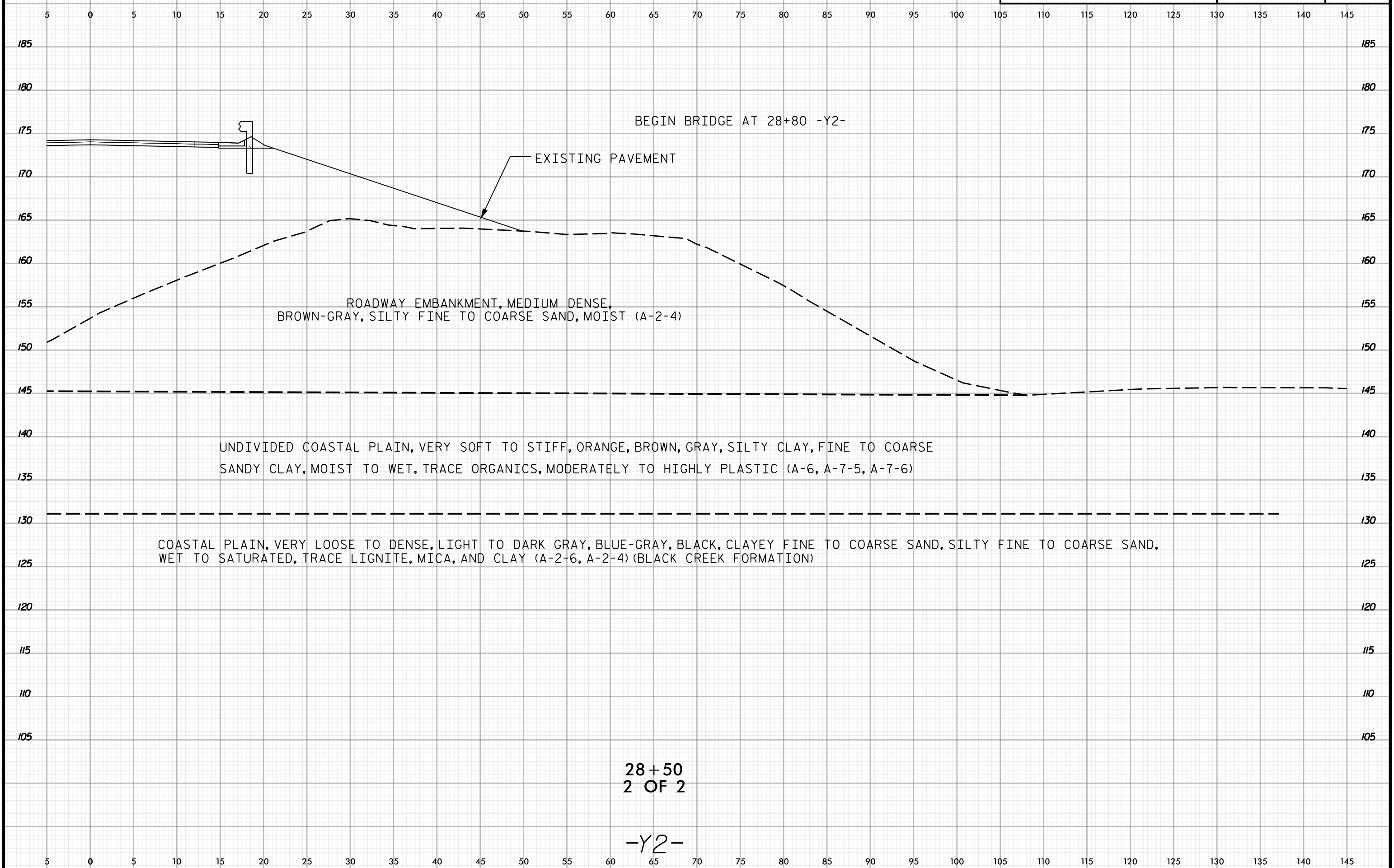

28+50
2 OF 2

-Y2-



75 70 65 60 55 50 45 40 35 30 25 20 15 10 5 0 5 10 15 20 25 30 35 40 45 50 55 60 65 70 75

170 170

165 165

160 160

155 155

150 150

145 145

140 140

135 135

130 130

125 125

120 120

115 115

110 110

75 70 65 60 55 50 45 40 35 30 25 20 15 10 5 0 5 10 15 20 25 30 35 40 45 50 55 60 65 70 75

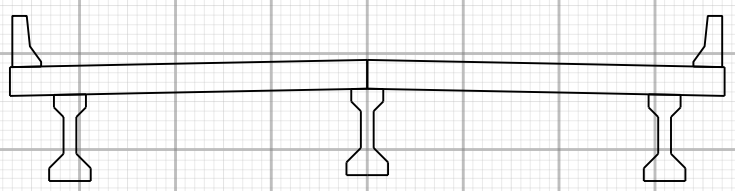

SS-119T
SS-120T

Y2_EB1-B
28+91 -Y2-
19' RT

CONCRETE

UNDIVIDED COASTAL PLAIN MEDIUM STIFF TO STIFF, GRAY, BROWN, ORANGE, COARSE

4
8

TO FINE SANDY CLAY, MOIST, TRACE ORGANICS, MODERATELY PLASTIC (A-6)

COASTAL PLAIN STIFF, DARK GRAY, SILTY CLAY, MOIST,

11
8

HIGHLY PLASTIC (A-7-6) (BLACK CREEK FORMATION)

VERY LOOSE TO MEDIUM DENSE, LIGHT GRAY, ORANGE, GRAY, CLAYEY COARSE

13

TO FINE SAND, MOIST TO SATURATED, MODERATELY PLASTIC (A-2-6)

WOH

VERY LOOSE TO MEDIUM DENSE, DARK GRAY, SILTY COARSE

6

TO FINE SAND, SATURATED, NON PLASTIC (A-2-5)

2

BORING TRUNCATED SEE STRUCTURE REPORT FOR COMPLETE BORING INFORMATION

29+00

-Y2-

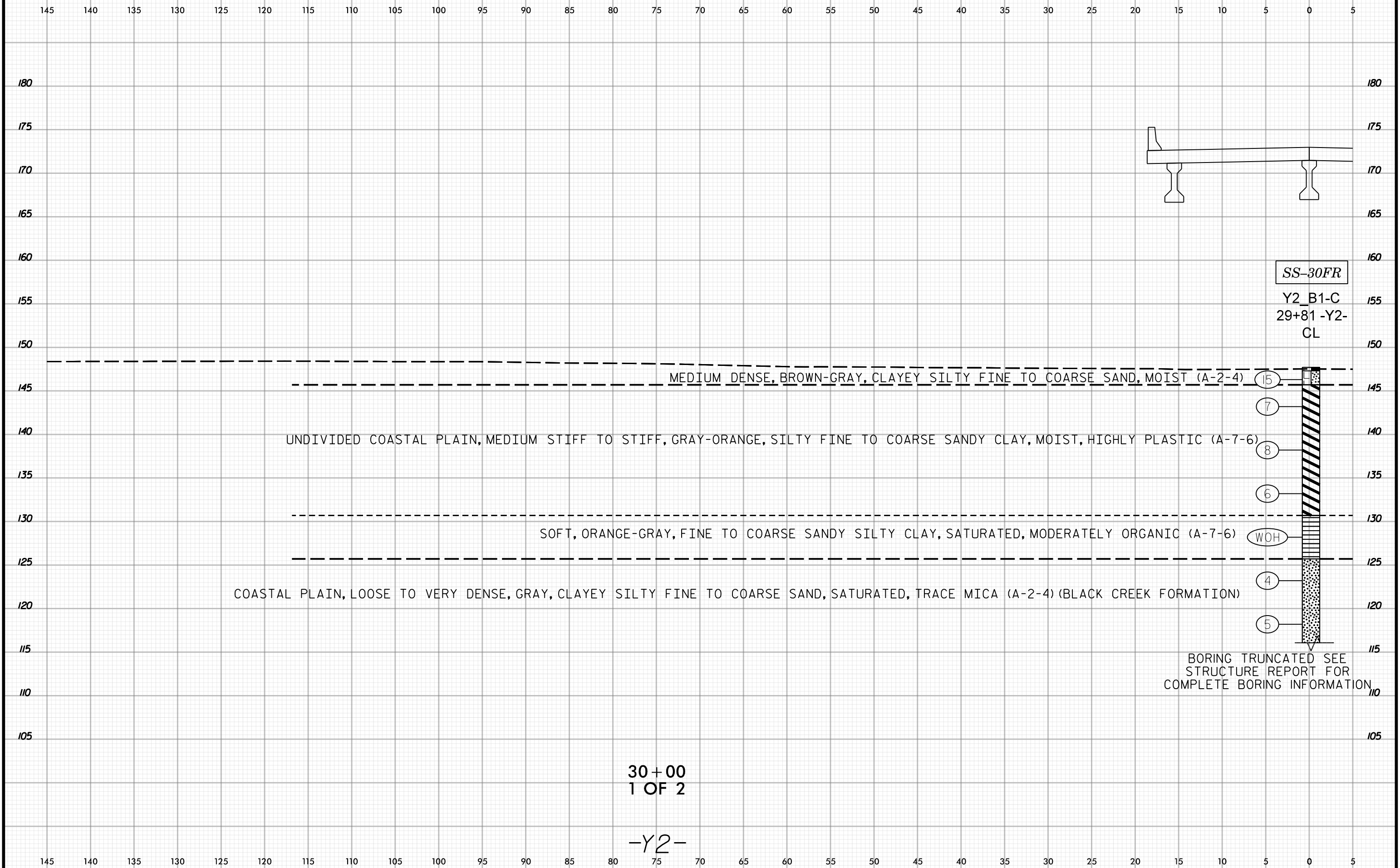

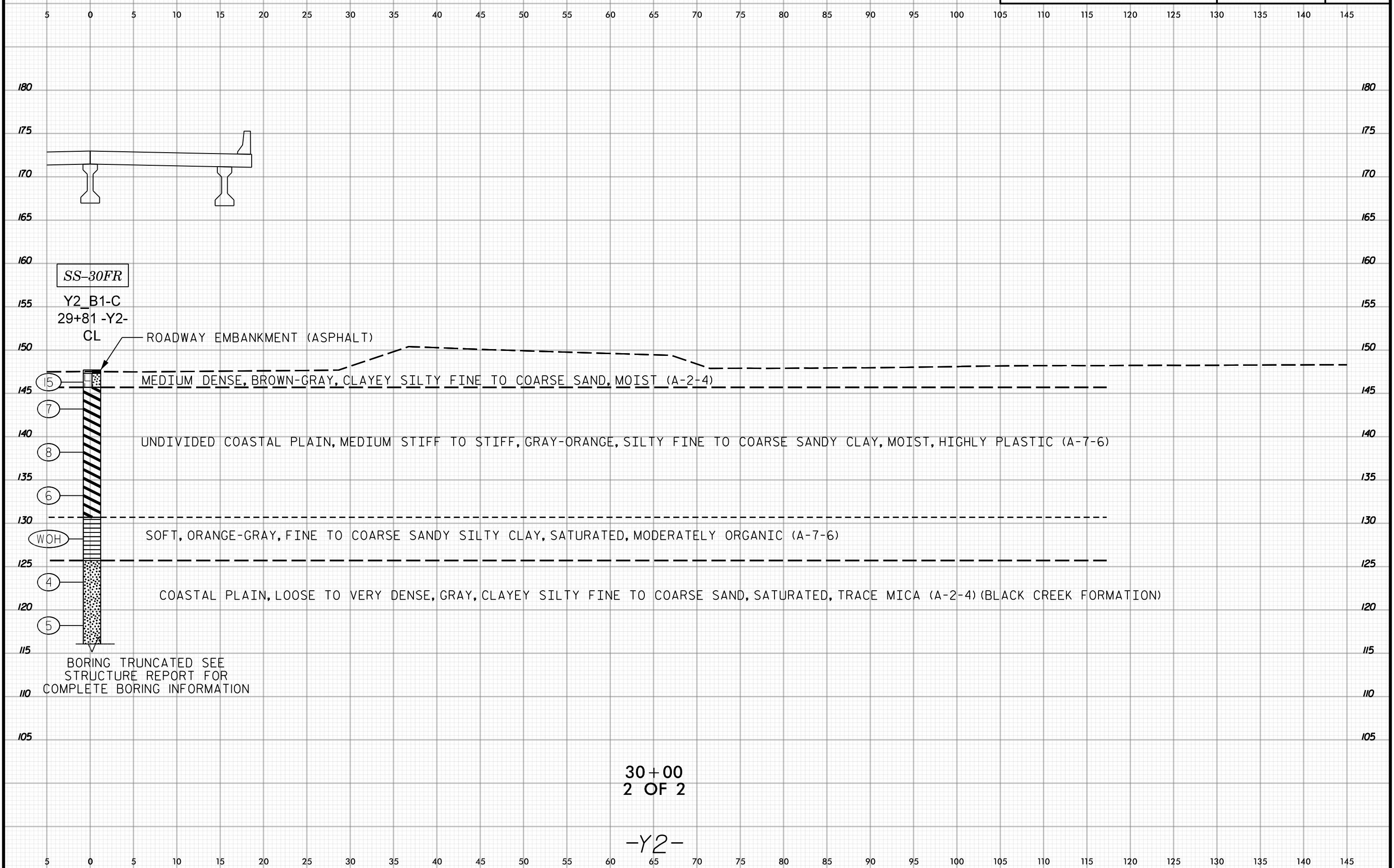
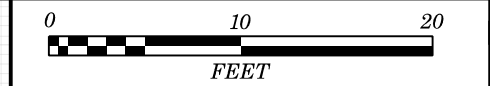

SS-30FR

Y2_B1-C
29+81 -Y2-

CL ROADWAY EMBANKMENT (ASPHALT)

15

MEDIUM DENSE, BROWN-GRAY, CLAYEY SILTY FINE TO COARSE SAND, MOIST (A-2-4)

7

UNDIVIDED COASTAL PLAIN, MEDIUM STIFF TO STIFF, GRAY-ORANGE, SILTY FINE TO COARSE SANDY CLAY, MOIST, HIGHLY PLASTIC (A-7-6)

8

6

SOFT, ORANGE-GRAY, FINE TO COARSE SANDY SILTY CLAY, SATURATED, MODERATELY ORGANIC (A-7-6)

WOH

4

COASTAL PLAIN, LOOSE TO VERY DENSE, GRAY, CLAYEY SILTY FINE TO COARSE SAND, SATURATED, TRACE MICA (A-2-4) (BLACK CREEK FORMATION)

5

BORING TRUNCATED SEE
STRUCTURE REPORT FOR
COMPLETE BORING INFORMATION

30+00
2 OF 2

-Y2-

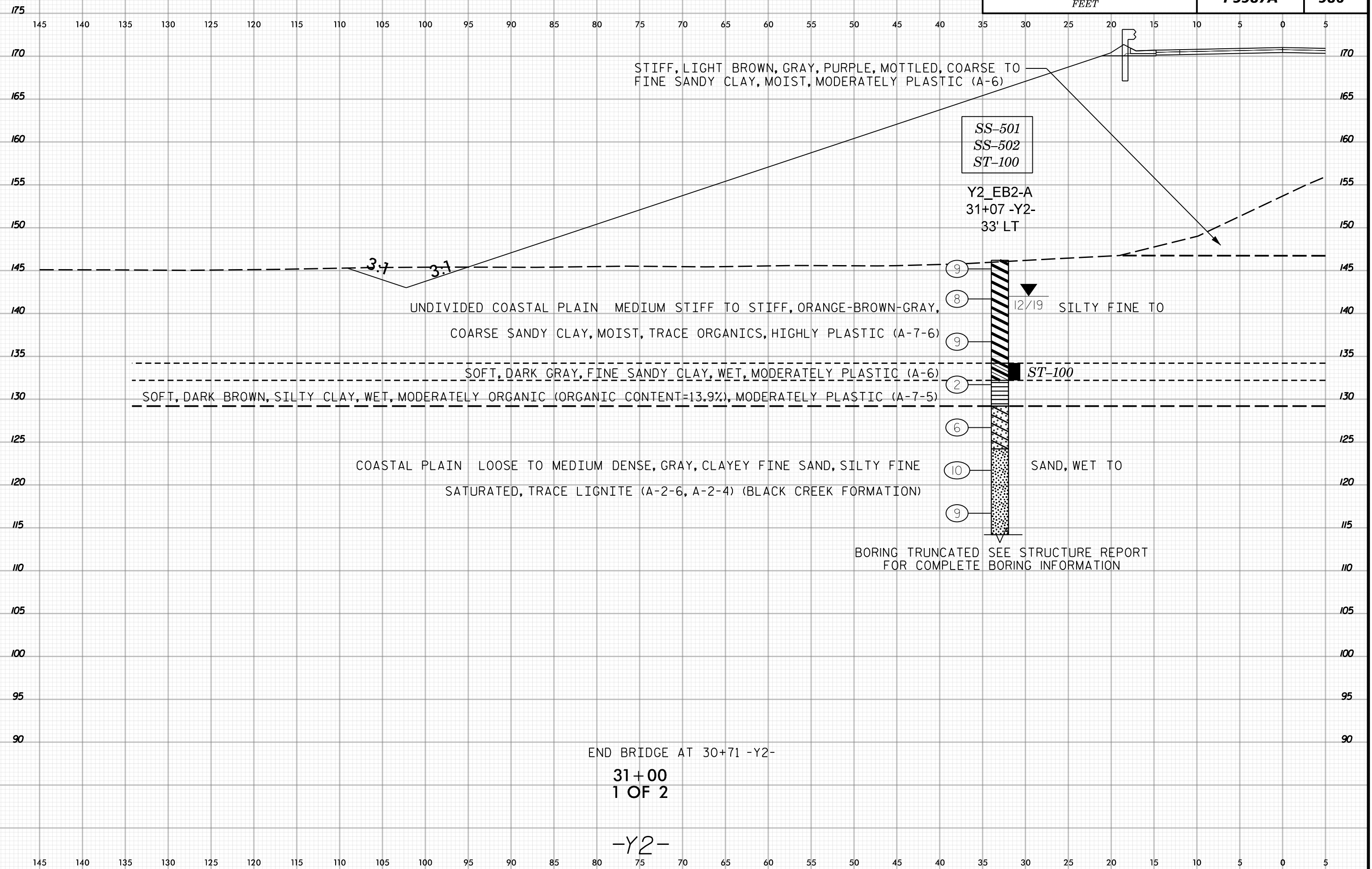

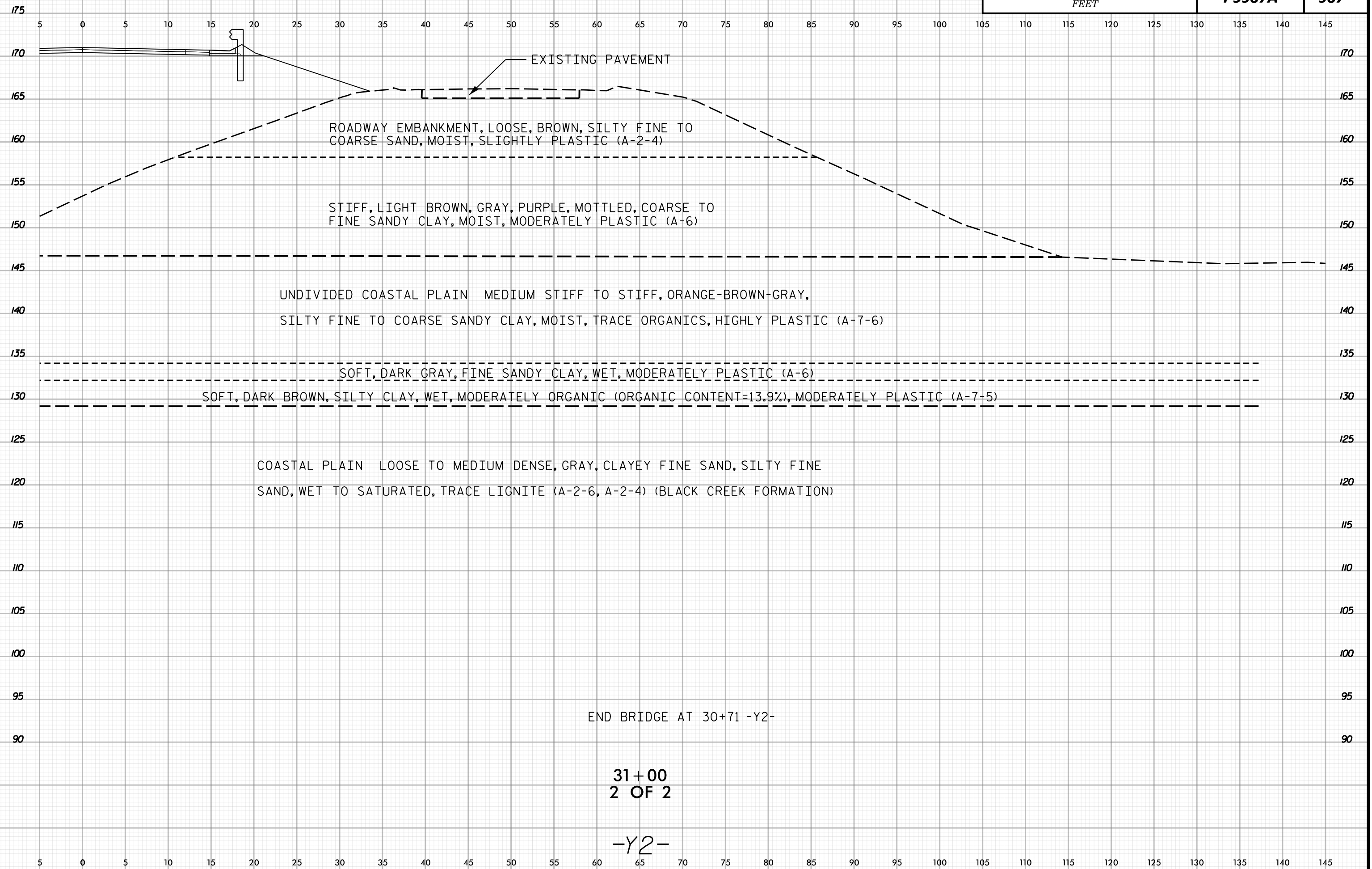

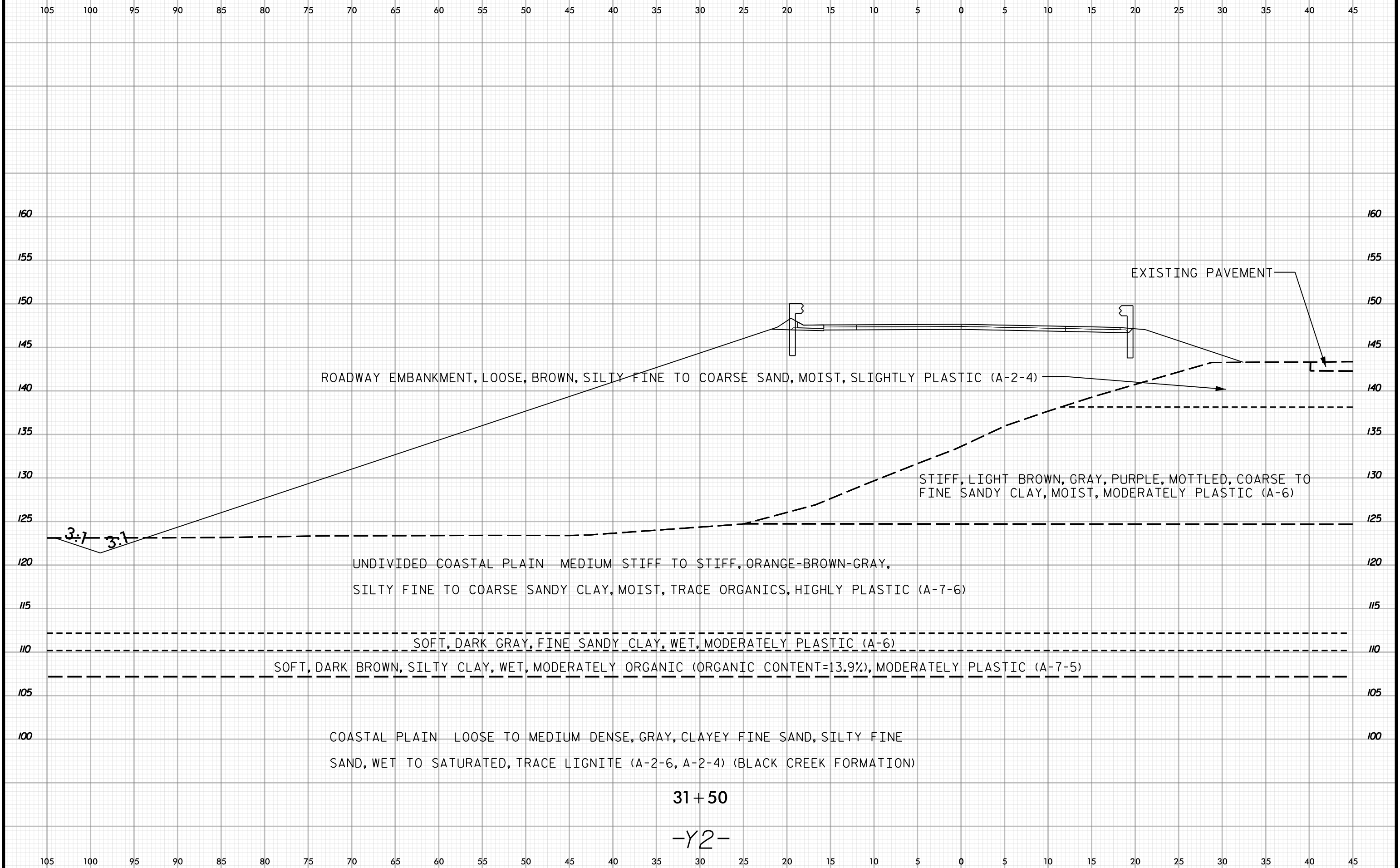

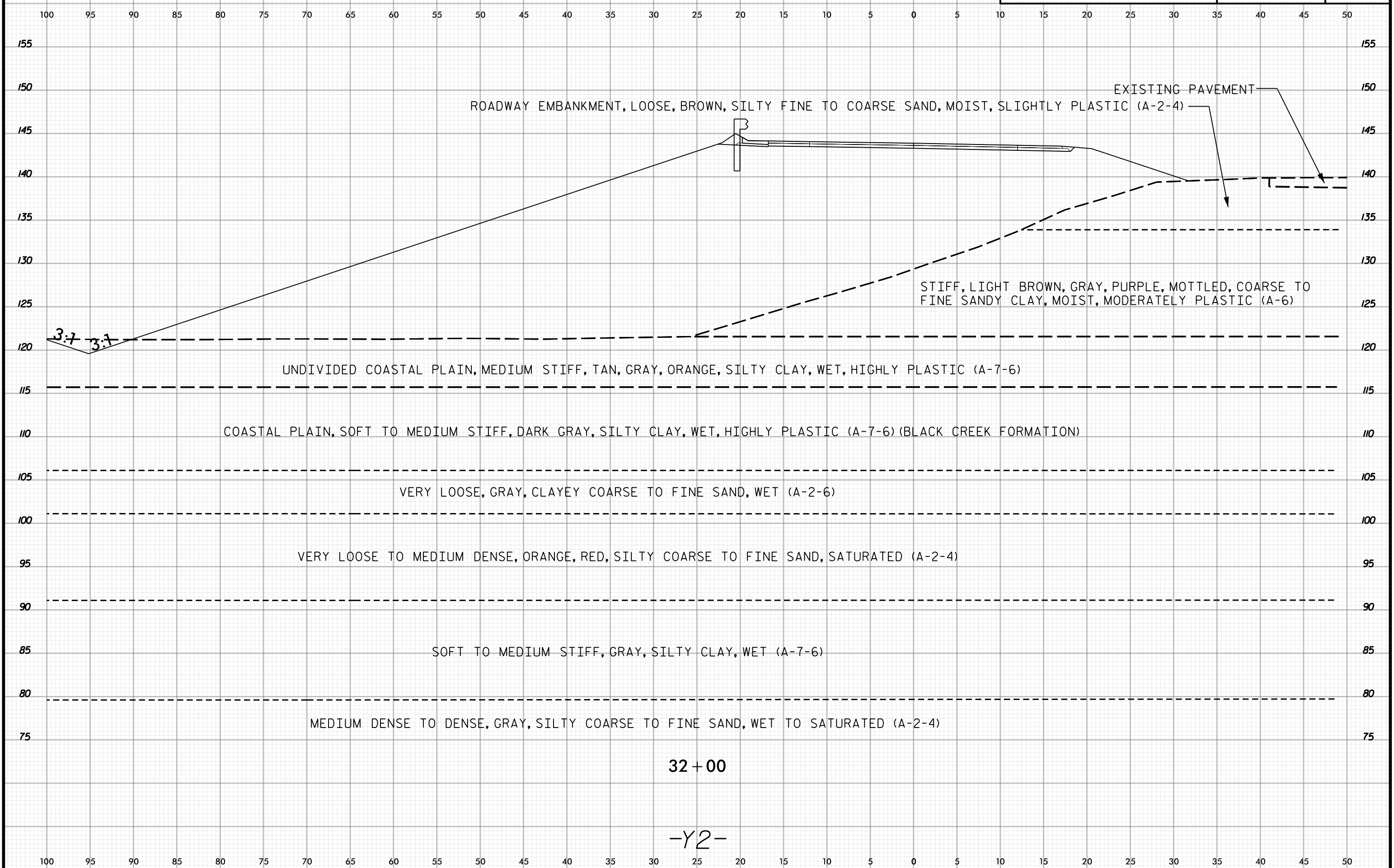

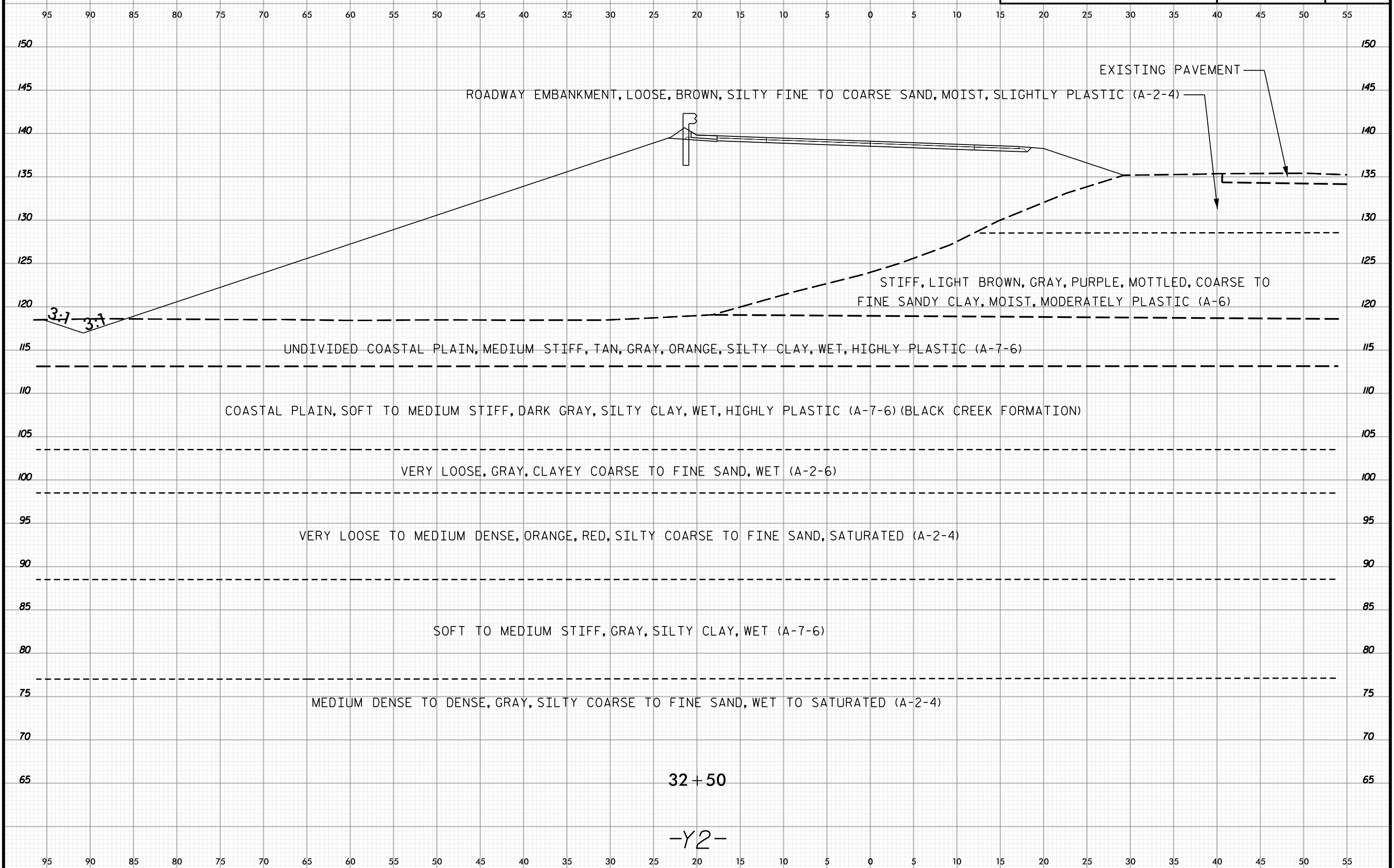

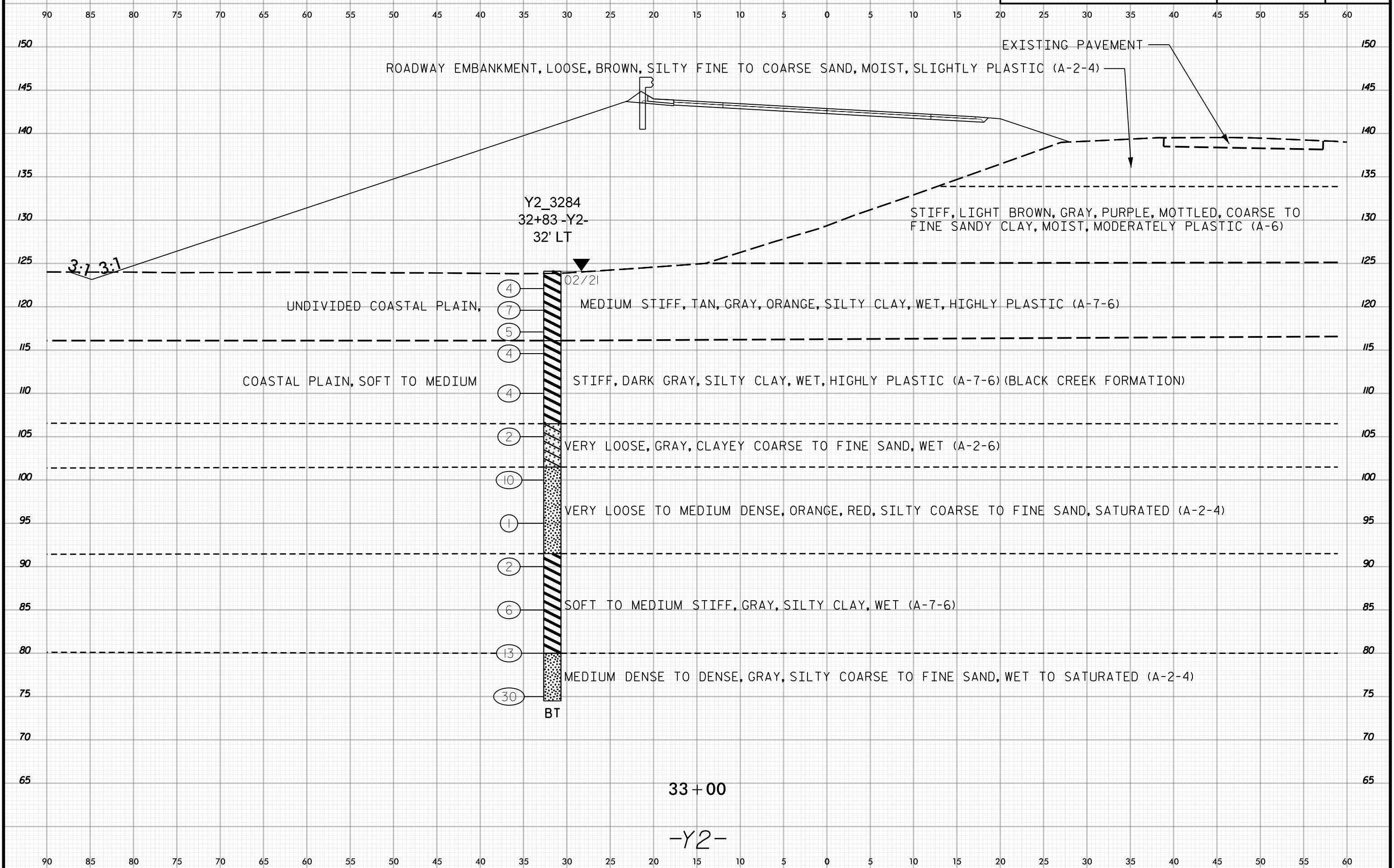
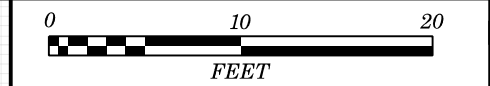

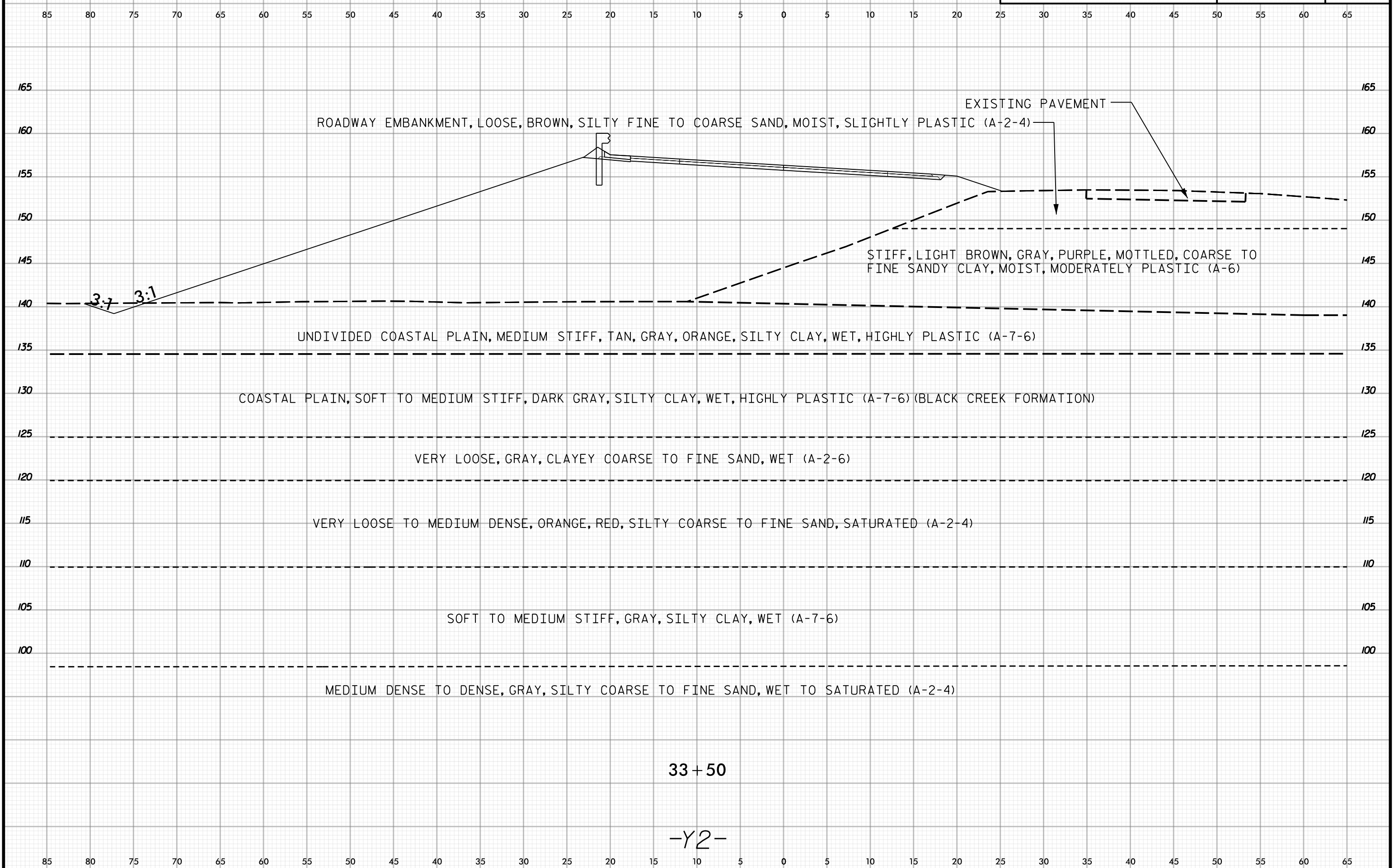

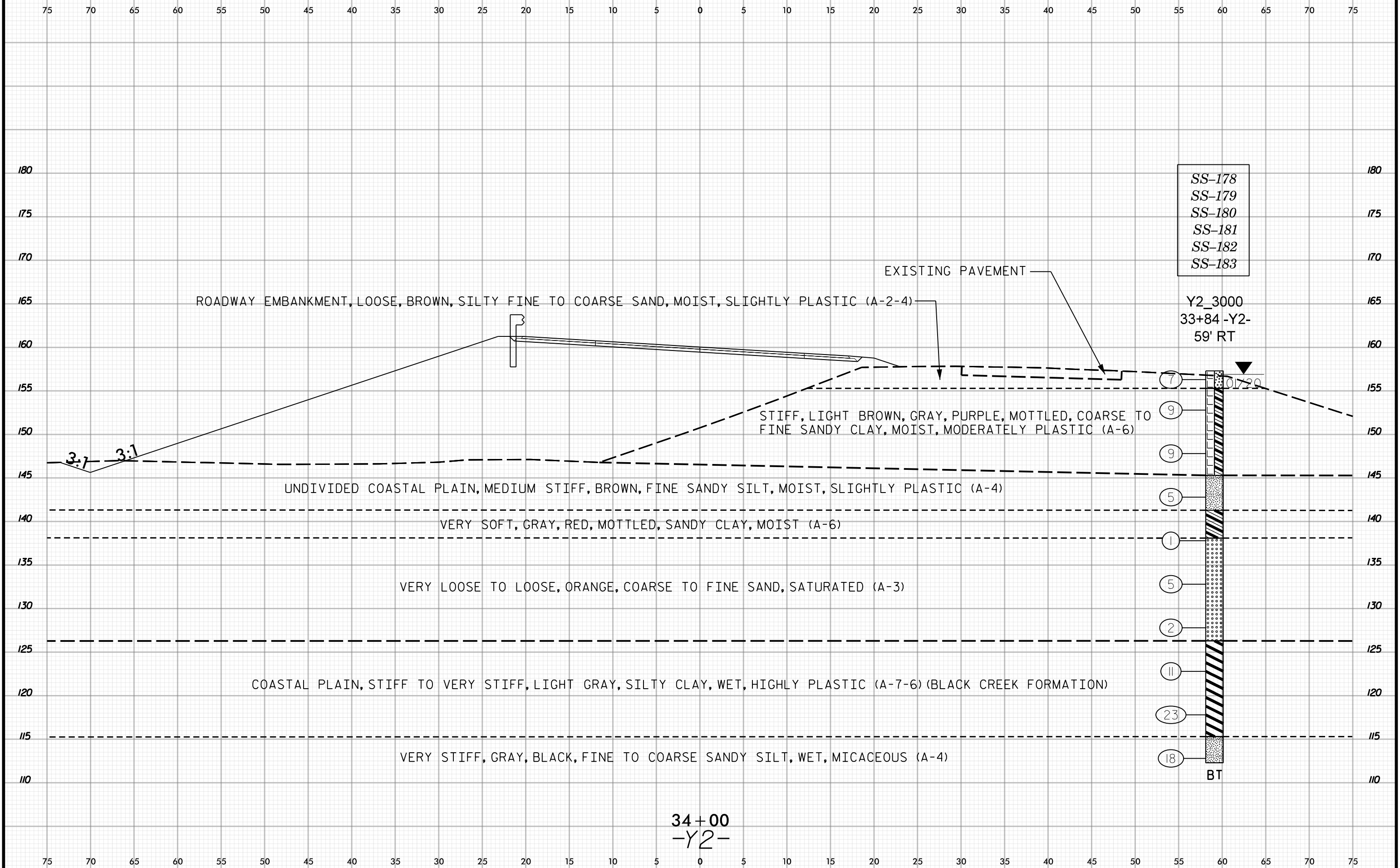

- SS-178
- SS-179
- SS-180
- SS-181
- SS-182
- SS-183

Y2_3000
33+84 -Y2-
59' RT

34+00
-Y2-

BT

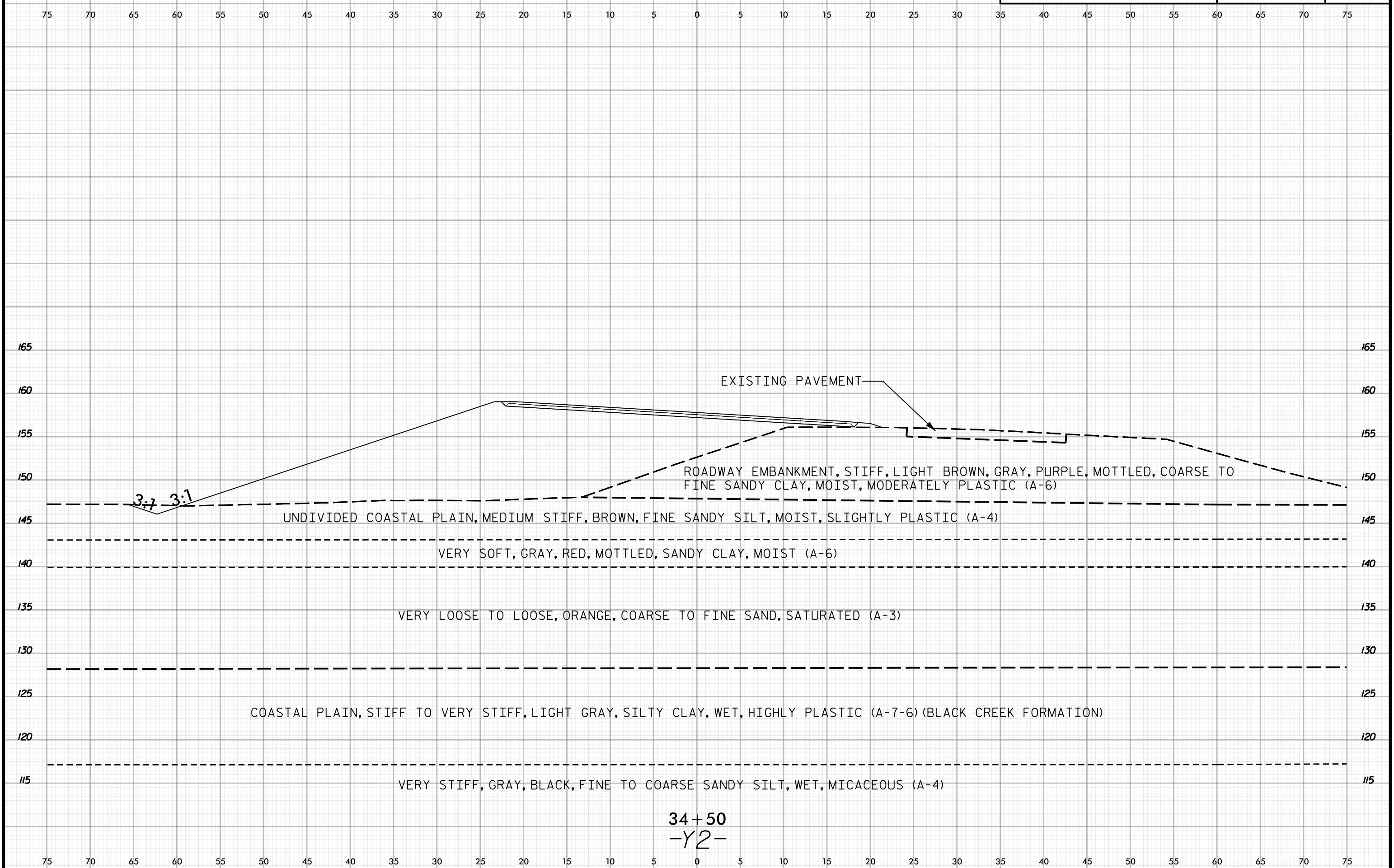

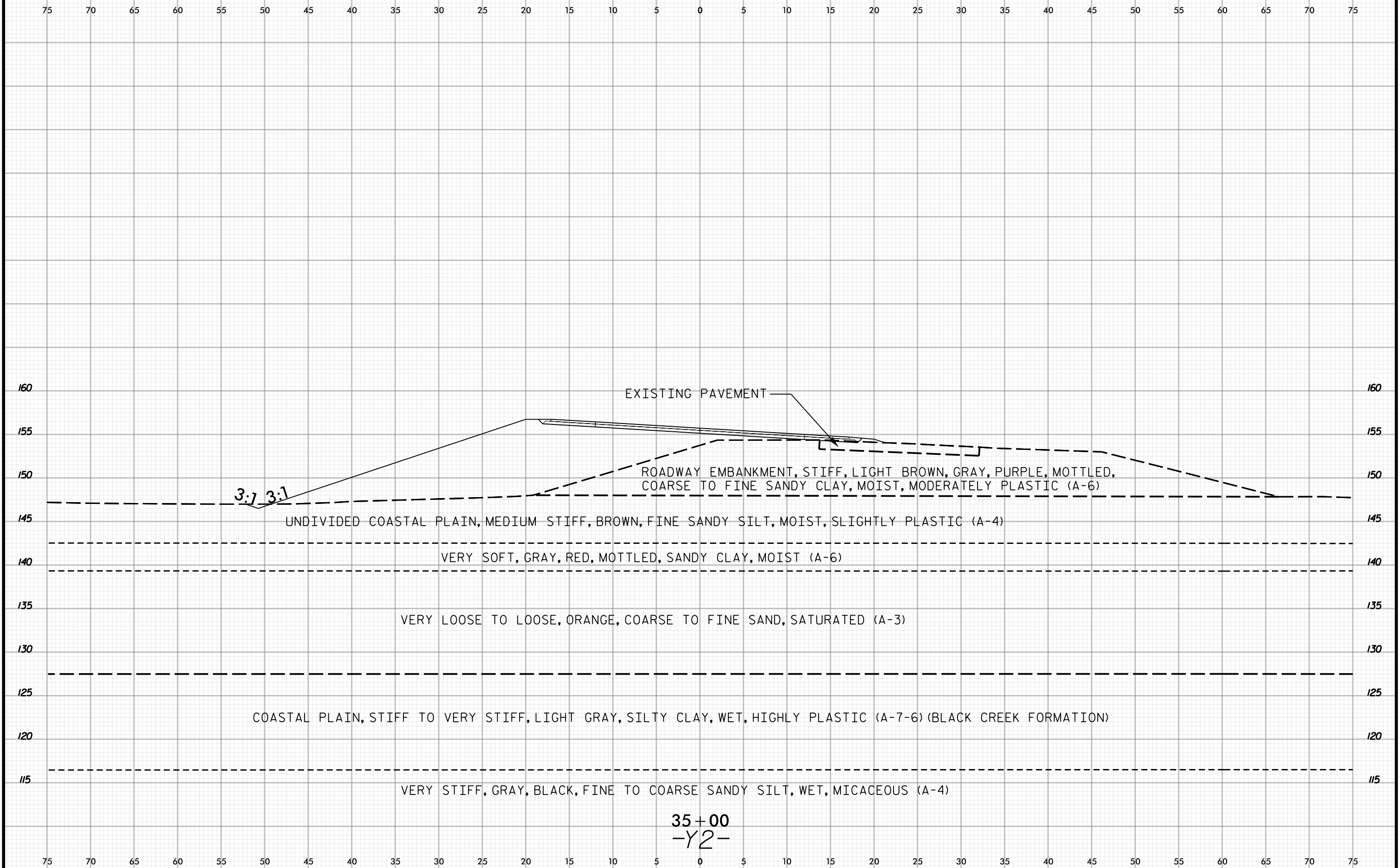

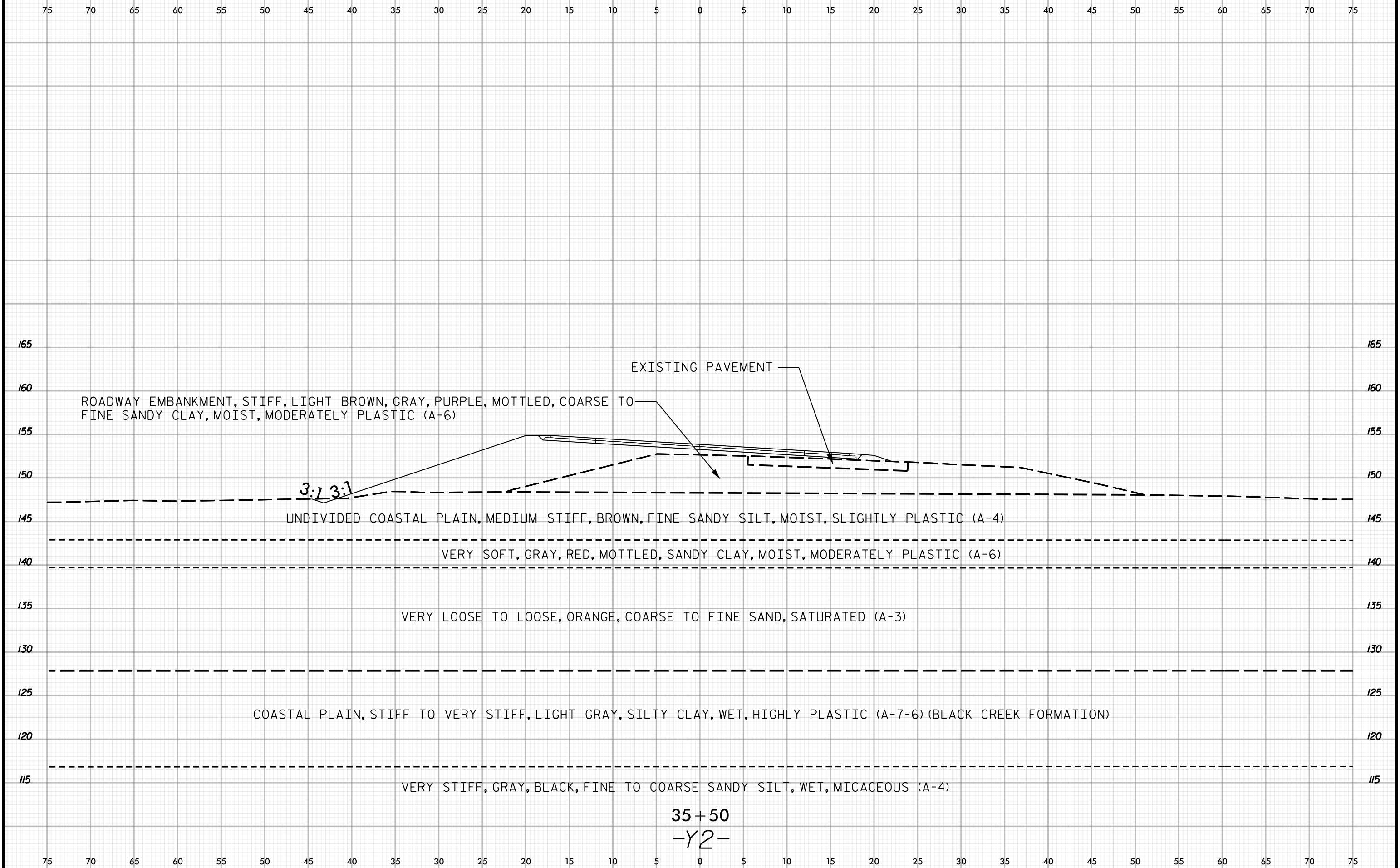

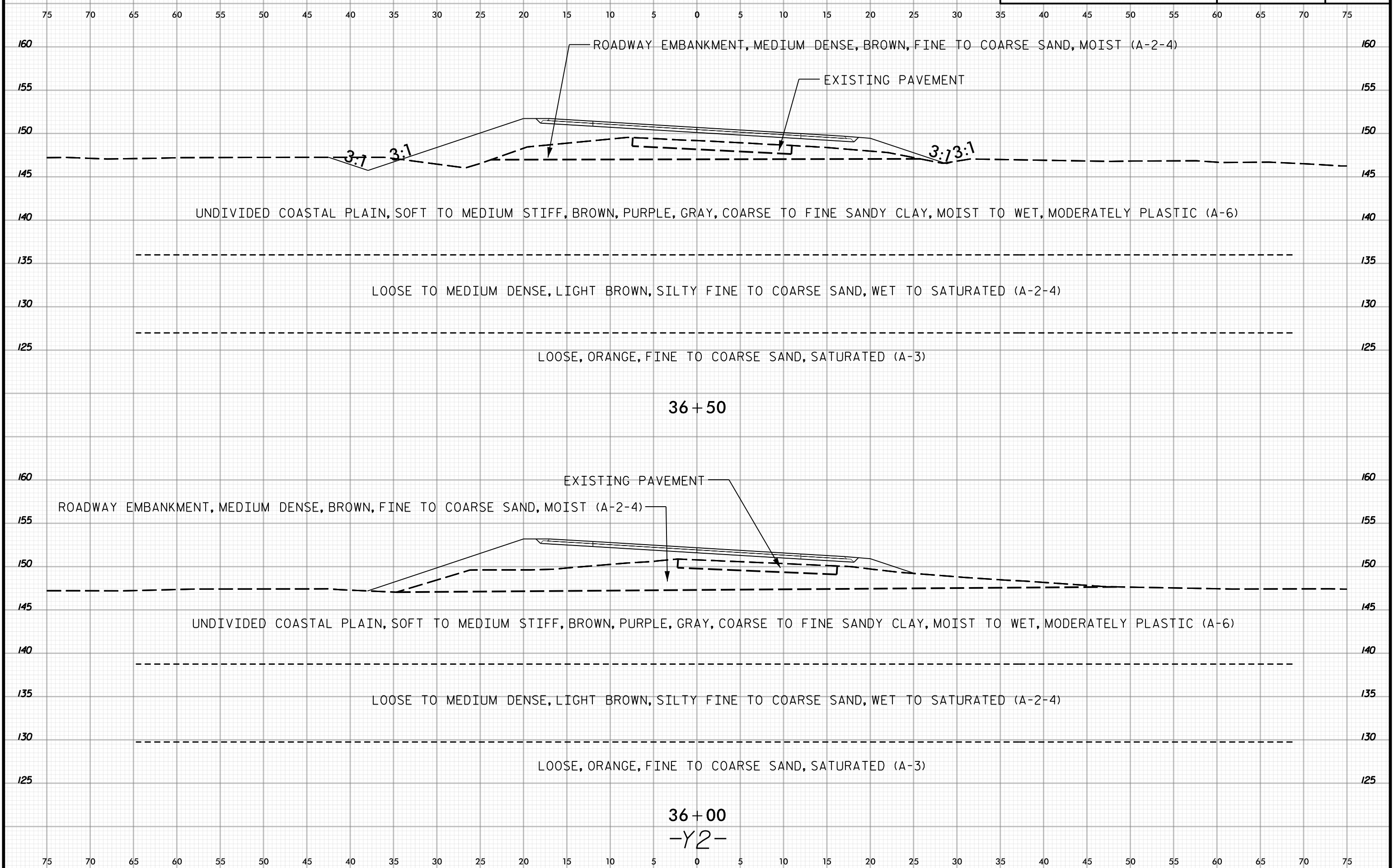

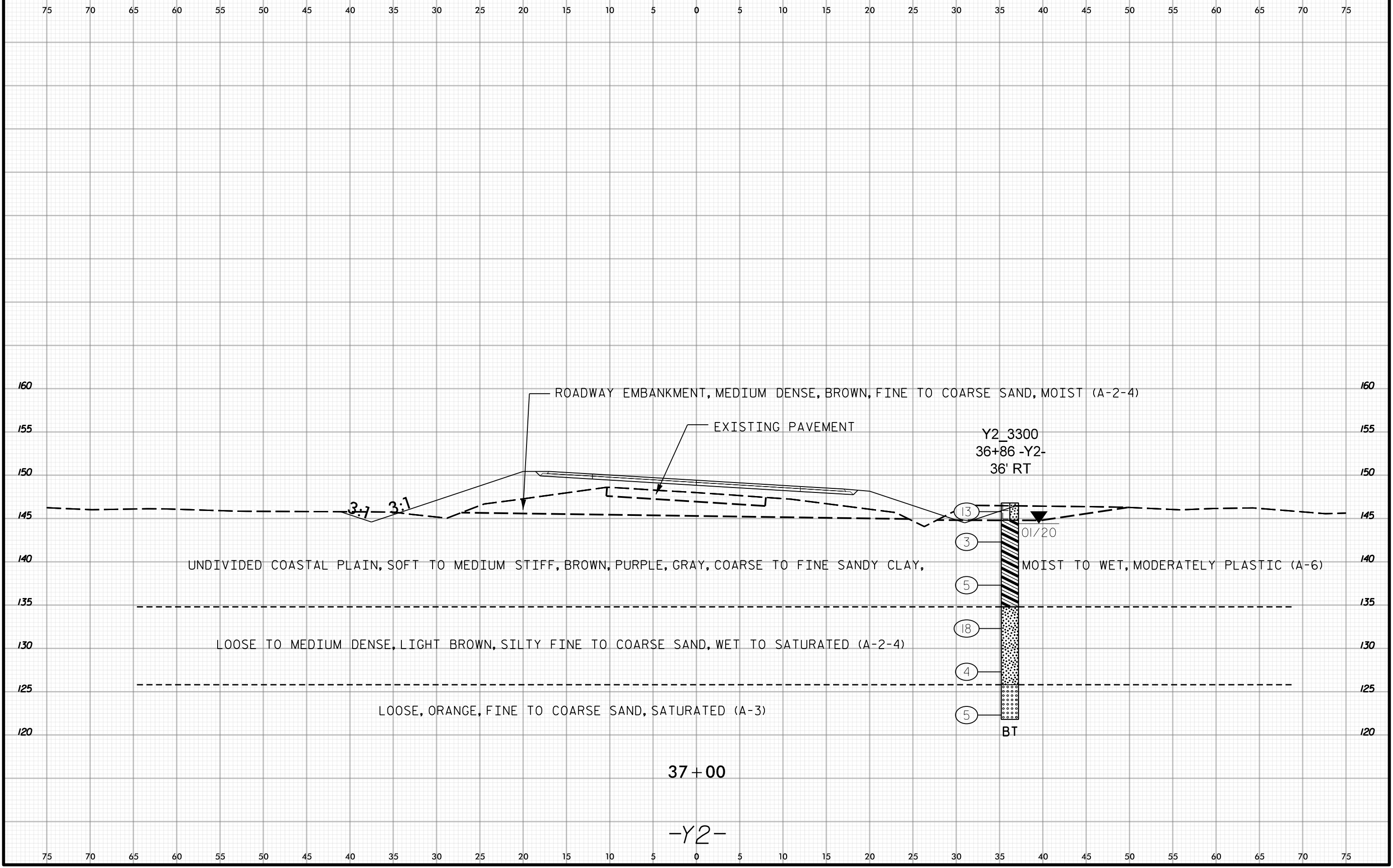
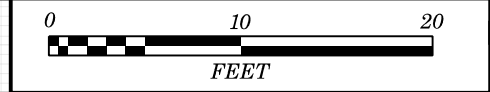

37+00

-Y2-

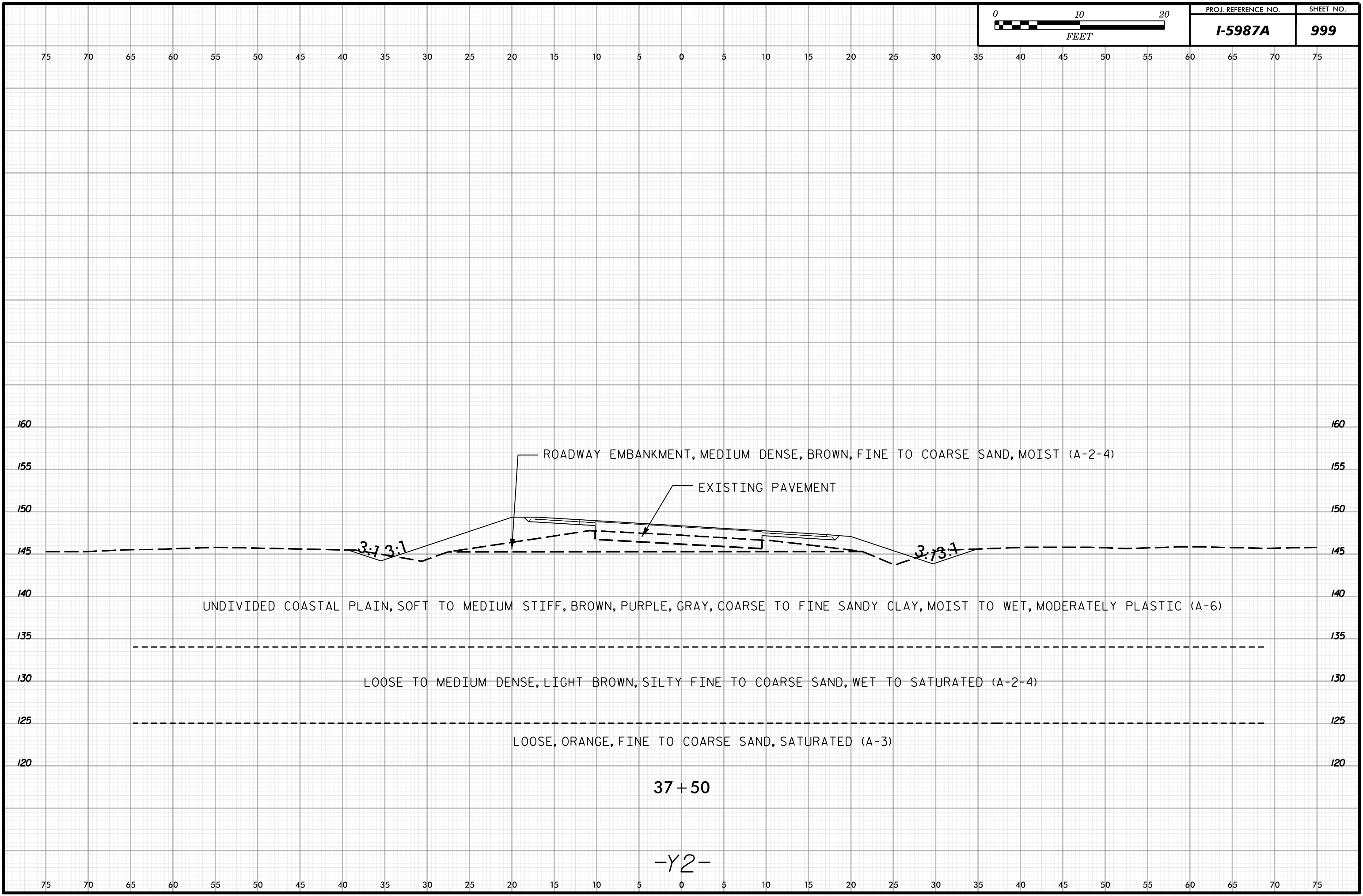

37+50

-Y2-

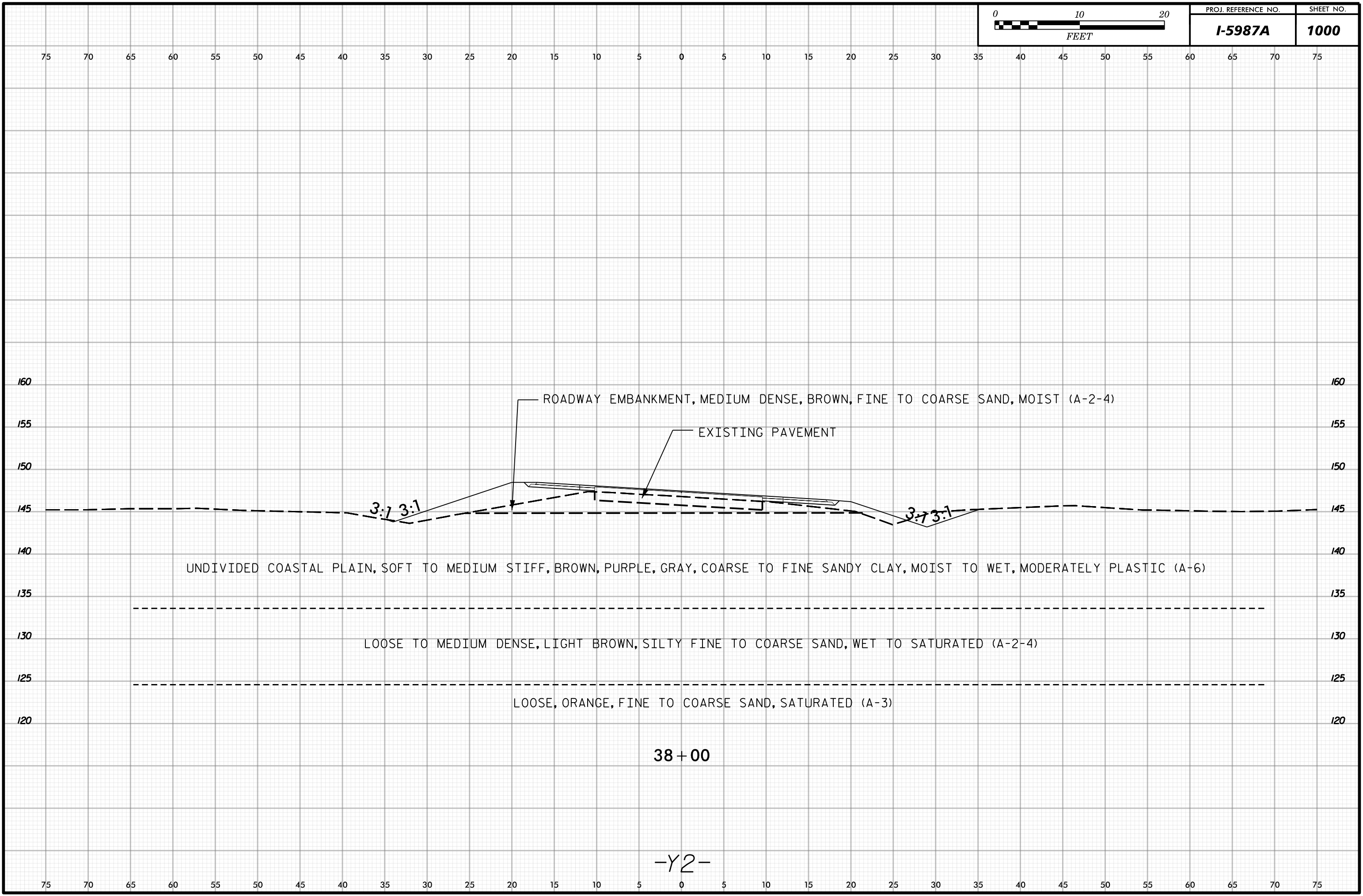

ROADWAY EMBANKMENT, MEDIUM DENSE, BROWN, FINE TO COARSE SAND, MOIST (A-2-4)

EXISTING PAVEMENT

3:1 3:1

3:1 3:1

UNDIVIDED COASTAL PLAIN, SOFT TO MEDIUM STIFF, BROWN, PURPLE, GRAY, COARSE TO FINE SANDY CLAY, MOIST TO WET, MODERATELY PLASTIC (A-6)

LOOSE TO MEDIUM DENSE, LIGHT BROWN, SILTY FINE TO COARSE SAND, WET TO SATURATED (A-2-4)

LOOSE, ORANGE, FINE TO COARSE SAND, SATURATED (A-3)

38 + 00

-Y2-

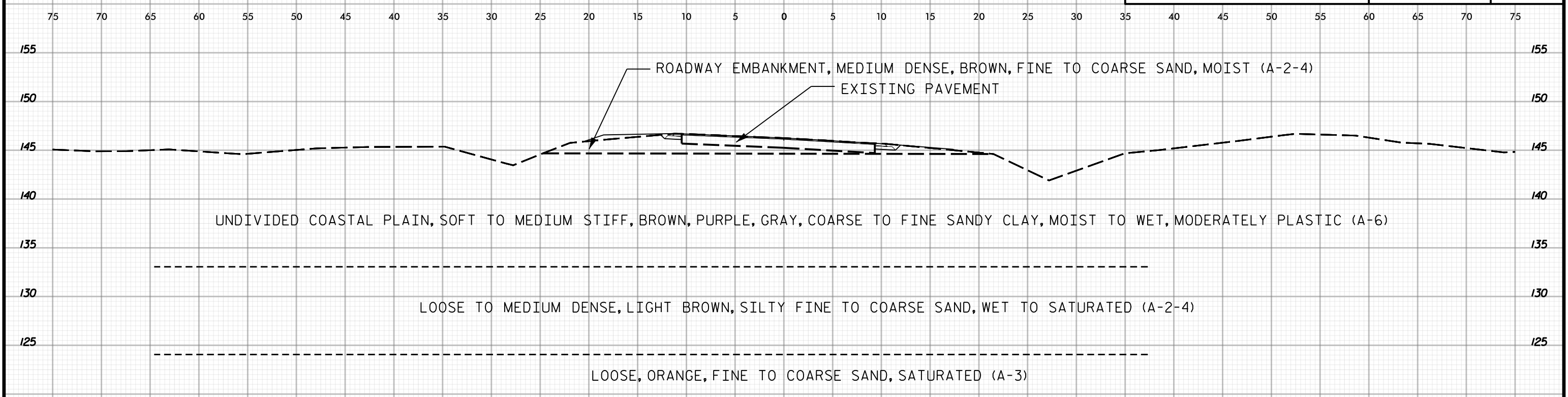

39+00

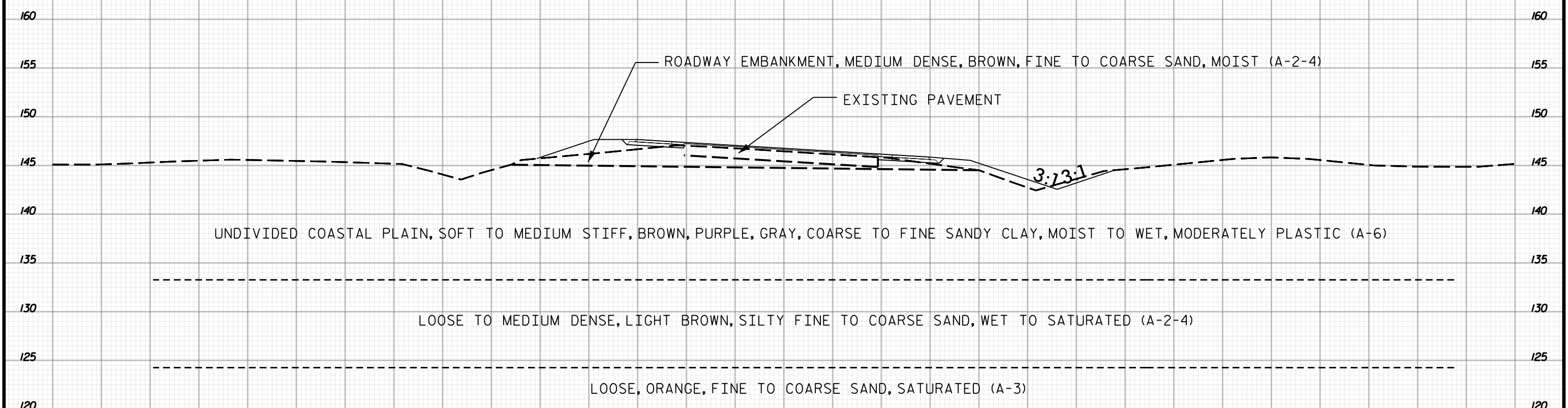

38+50

-Y2-



75 70 65 60 55 50 45 40 35 30 25 20 15 10 5 0 5 10 15 20 25 30 35 40 45 50 55 60 65 70 75

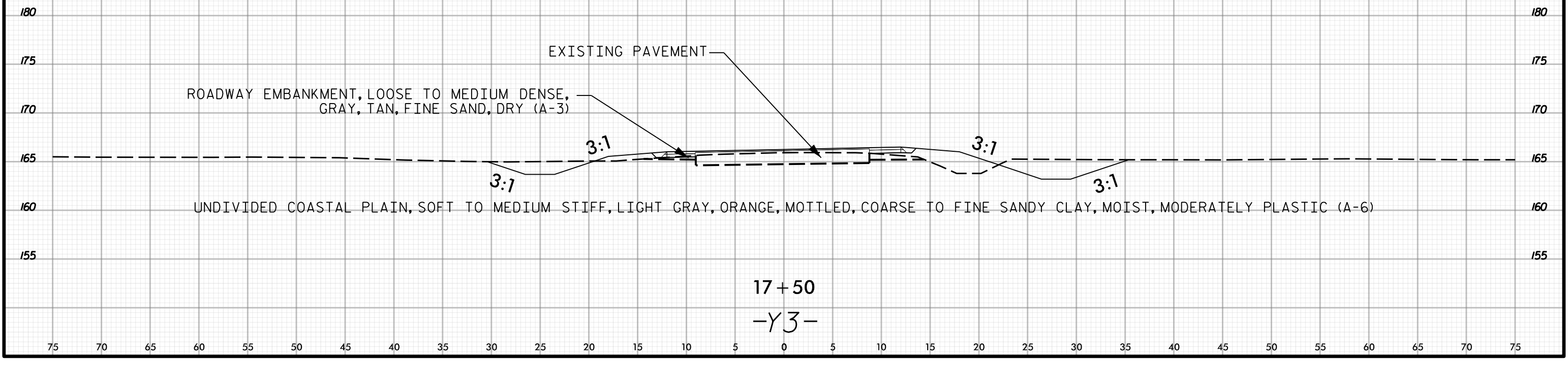
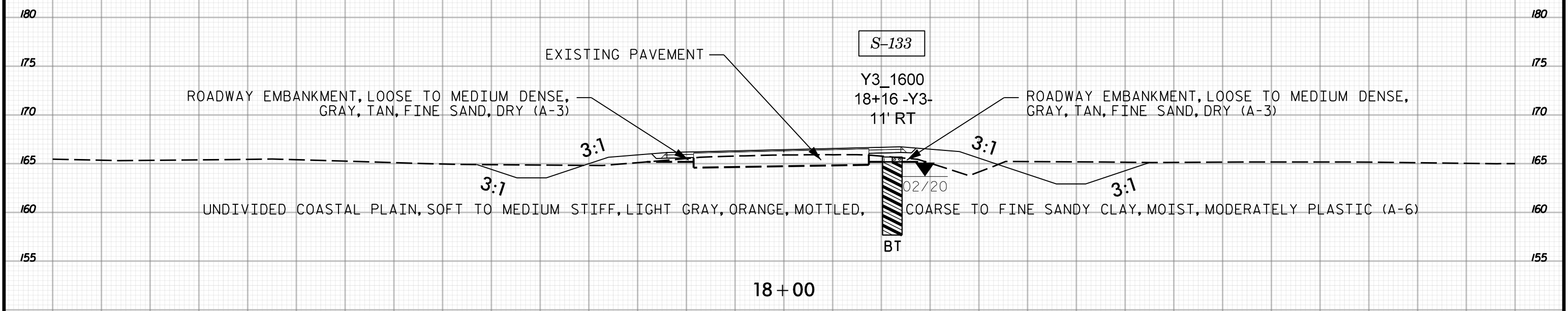

75 70 65 60 55 50 45 40 35 30 25 20 15 10 5 0 5 10 15 20 25 30 35 40 45 50 55 60 65 70 75

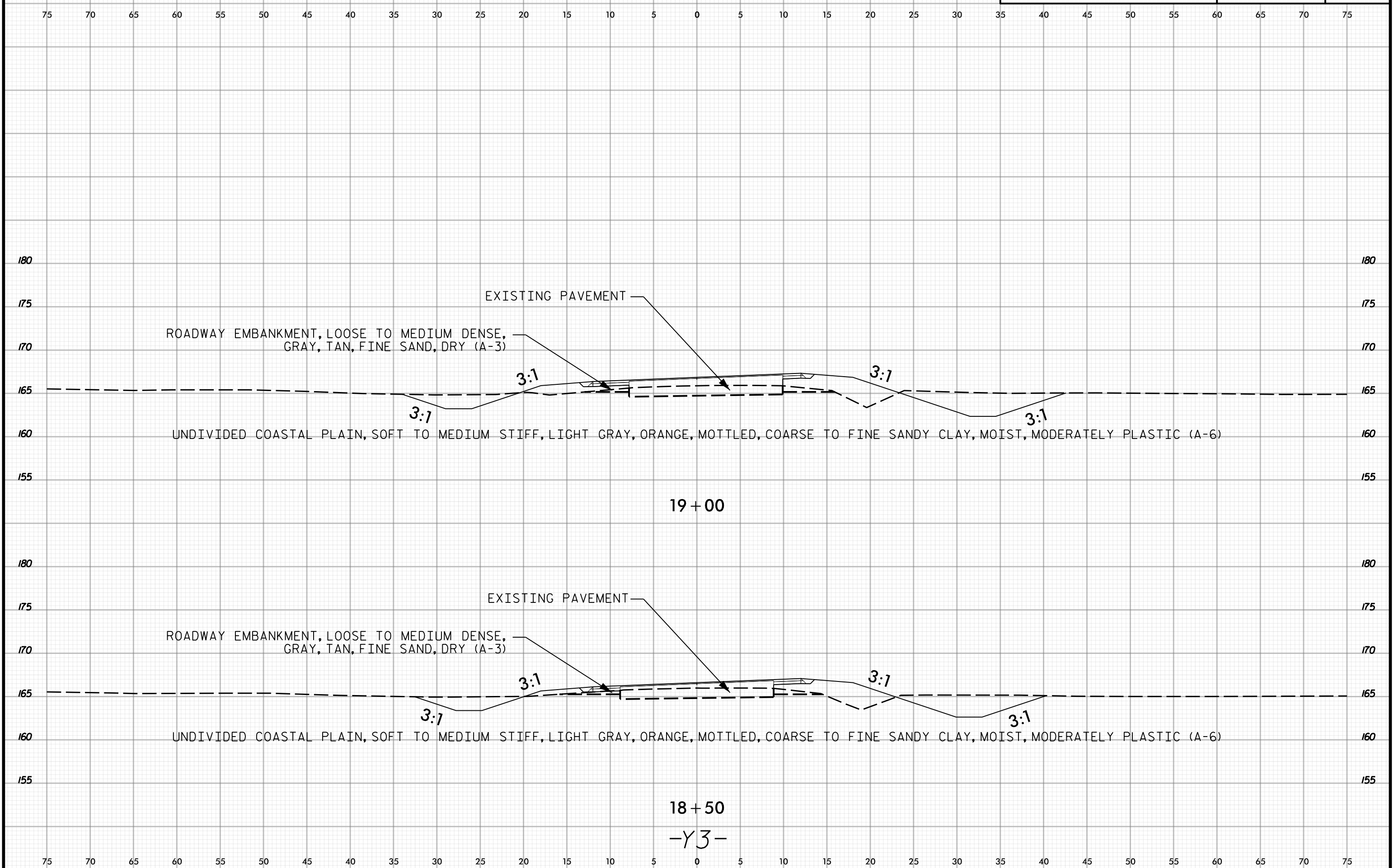

19 + 00

18 + 50

-Y3-



75 70 65 60 55 50 45 40 35 30 25 20 15 10 5 0 5 10 15 20 25 30 35 40 45 50 55 60 65 70 75

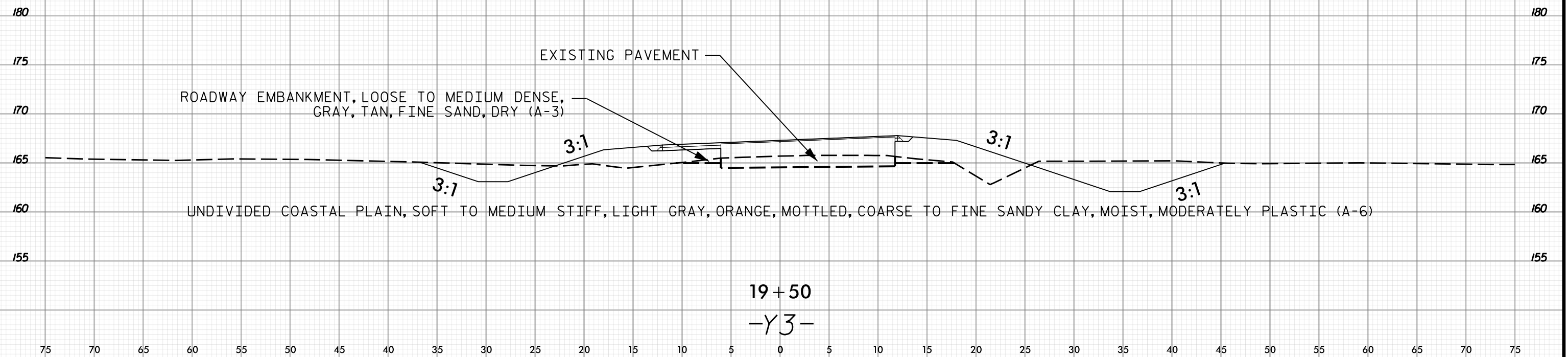
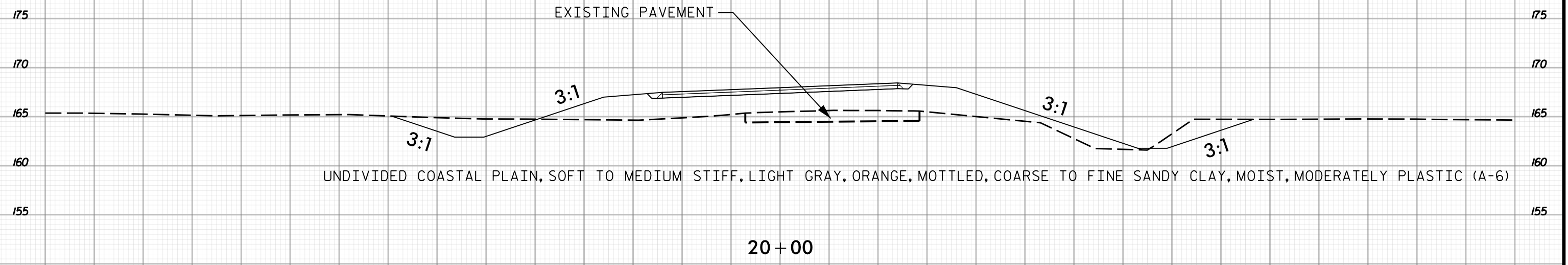

75 70 65 60 55 50 45 40 35 30 25 20 15 10 5 0 5 10 15 20 25 30 35 40 45 50 55 60 65 70 75

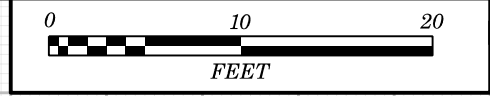

75 70 65 60 55 50 45 40 35 30 25 20 15 10 5 0 5 10 15 20 25 30 35 40 45 50 55 60 65 70 75

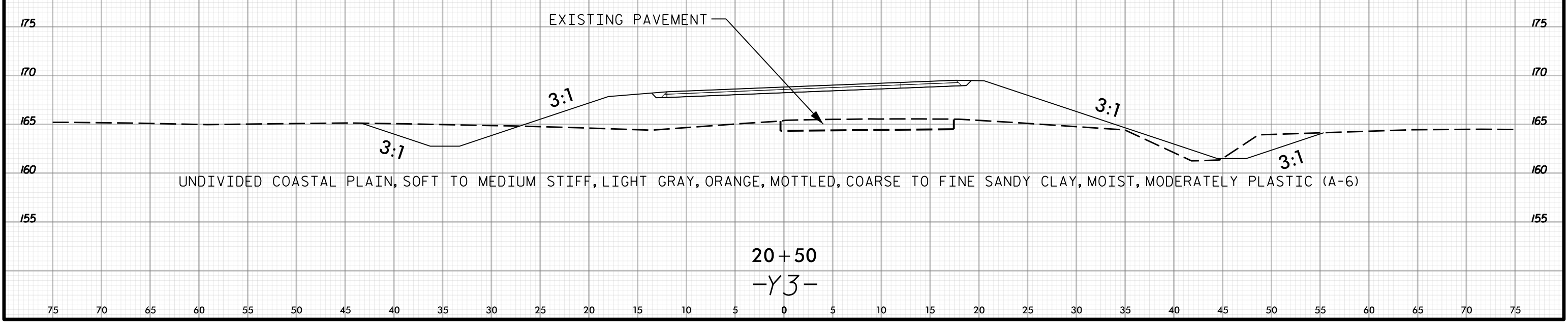
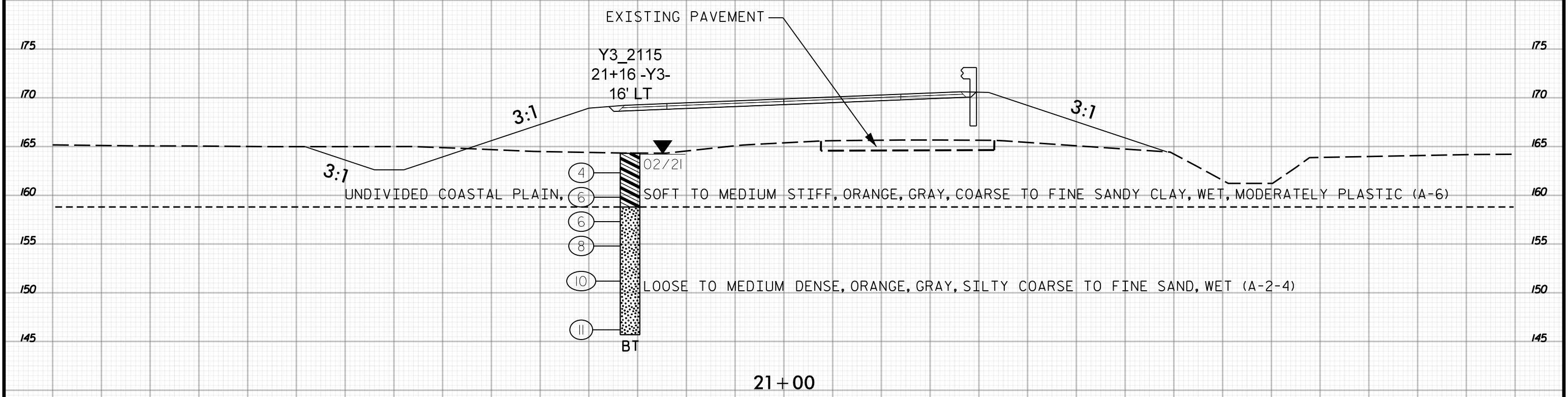

75 70 65 60 55 50 45 40 35 30 25 20 15 10 5 0 5 10 15 20 25 30 35 40 45 50 55 60 65 70 75

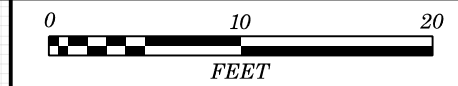

75 70 65 60 55 50 45 40 35 30 25 20 15 10 5 0 5 10 15 20 25 30 35 40 45 50 55 60 65 70 75

ROADWAY EMBANKMENT, LOOSE, TAN, ORANGE, GRAY, CLAYEY COARSE TO FINE SAND, SILTY COARSE TO FINE SAND, WET, SLIGHTLY PLASTIC, TRACE WOOD AND ROOT FRAGMENTS (A-2-6, A-2-4)

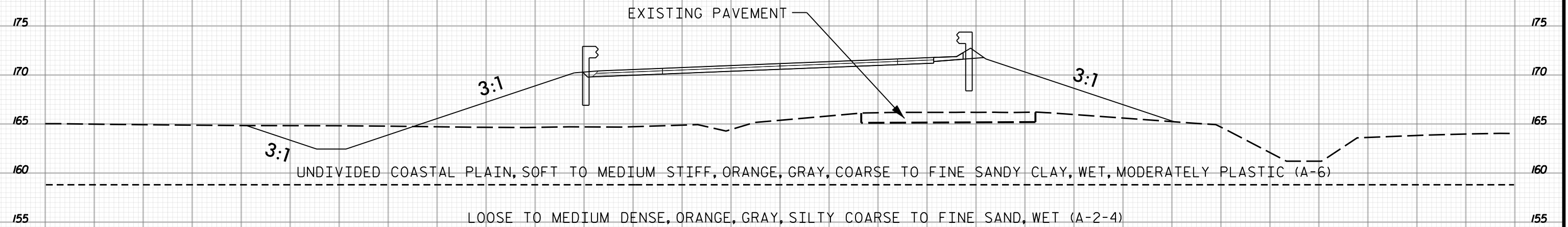
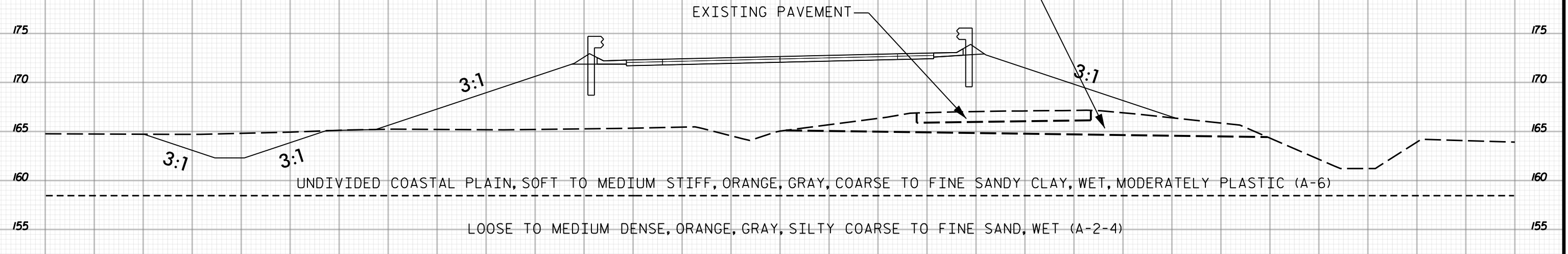

175 170 165 160 155 150 145

75 70 65 60 55 50 45 40 35 30 25 20 15 10 5 0 5 10 15 20 25 30 35 40 45 50 55 60 65 70 75

21+50
-Y3-

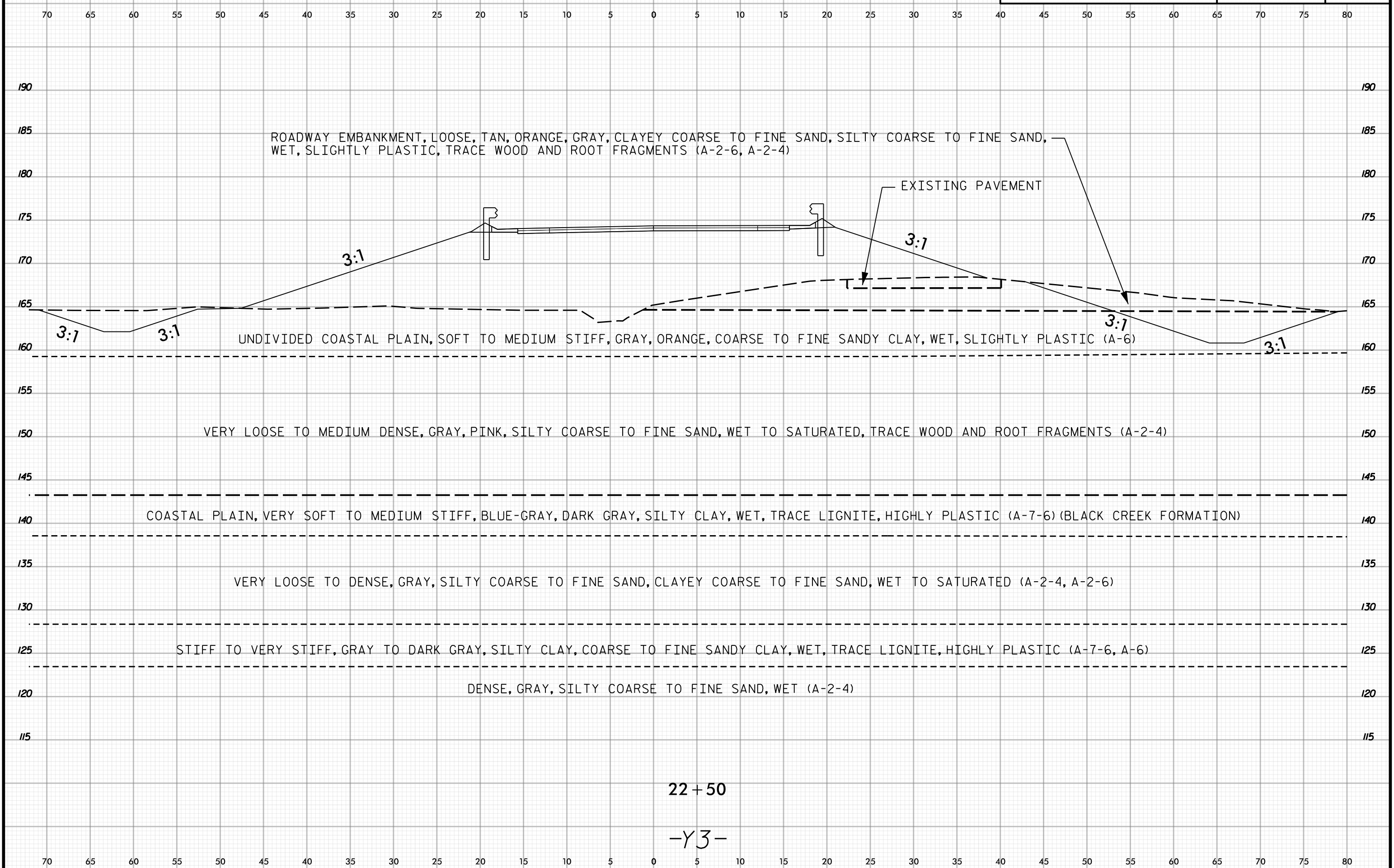

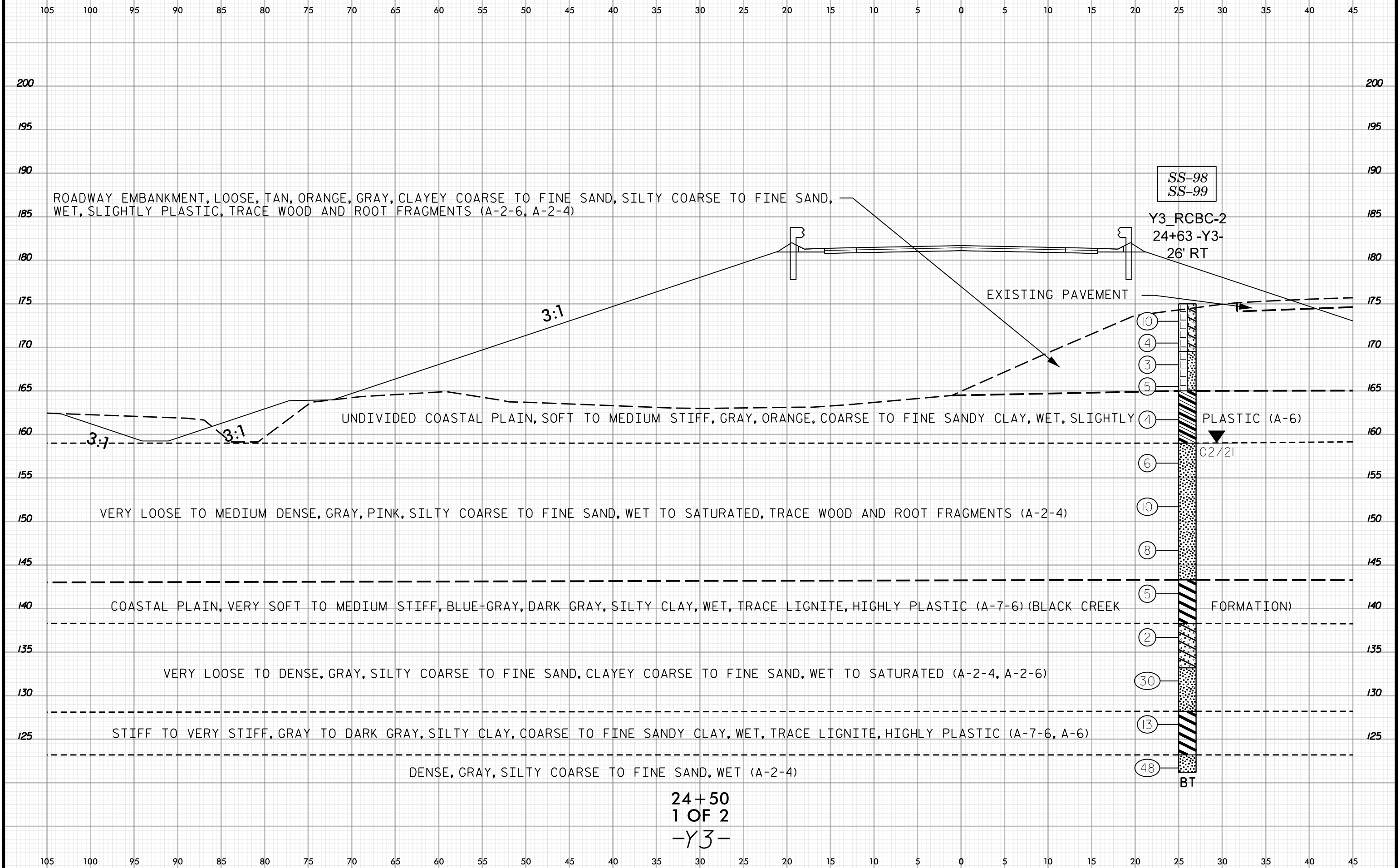
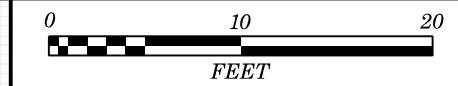

ROADWAY EMBANKMENT, LOOSE, TAN, ORANGE, GRAY, CLAYEY COARSE TO FINE SAND, SILTY COARSE TO FINE SAND, WET, SLIGHTLY PLASTIC, TRACE WOOD AND ROOT FRAGMENTS (A-2-6, A-2-4)

SS-98
SS-99

Y3_RCBC-2
24+63 -Y3-
26' RT

EXISTING PAVEMENT

3:1

UNDIVIDED COASTAL PLAIN, SOFT TO MEDIUM STIFF, GRAY, ORANGE, COARSE TO FINE SANDY CLAY, WET, SLIGHTLY PLASTIC (A-6)

PLASTIC (A-6)

02/21

VERY LOOSE TO MEDIUM DENSE, GRAY, PINK, SILTY COARSE TO FINE SAND, WET TO SATURATED, TRACE WOOD AND ROOT FRAGMENTS (A-2-4)

COASTAL PLAIN, VERY SOFT TO MEDIUM STIFF, BLUE-GRAY, DARK GRAY, SILTY CLAY, WET, TRACE LIGNITE, HIGHLY PLASTIC (A-7-6) (BLACK CREEK FORMATION)

VERY LOOSE TO DENSE, GRAY, SILTY COARSE TO FINE SAND, CLAYEY COARSE TO FINE SAND, WET TO SATURATED (A-2-4, A-2-6)

STIFF TO VERY STIFF, GRAY TO DARK GRAY, SILTY CLAY, COARSE TO FINE SANDY CLAY, WET, TRACE LIGNITE, HIGHLY PLASTIC (A-7-6, A-6)

DENSE, GRAY, SILTY COARSE TO FINE SAND, WET (A-2-4)

24+50
1 OF 2
-Y3-

BT

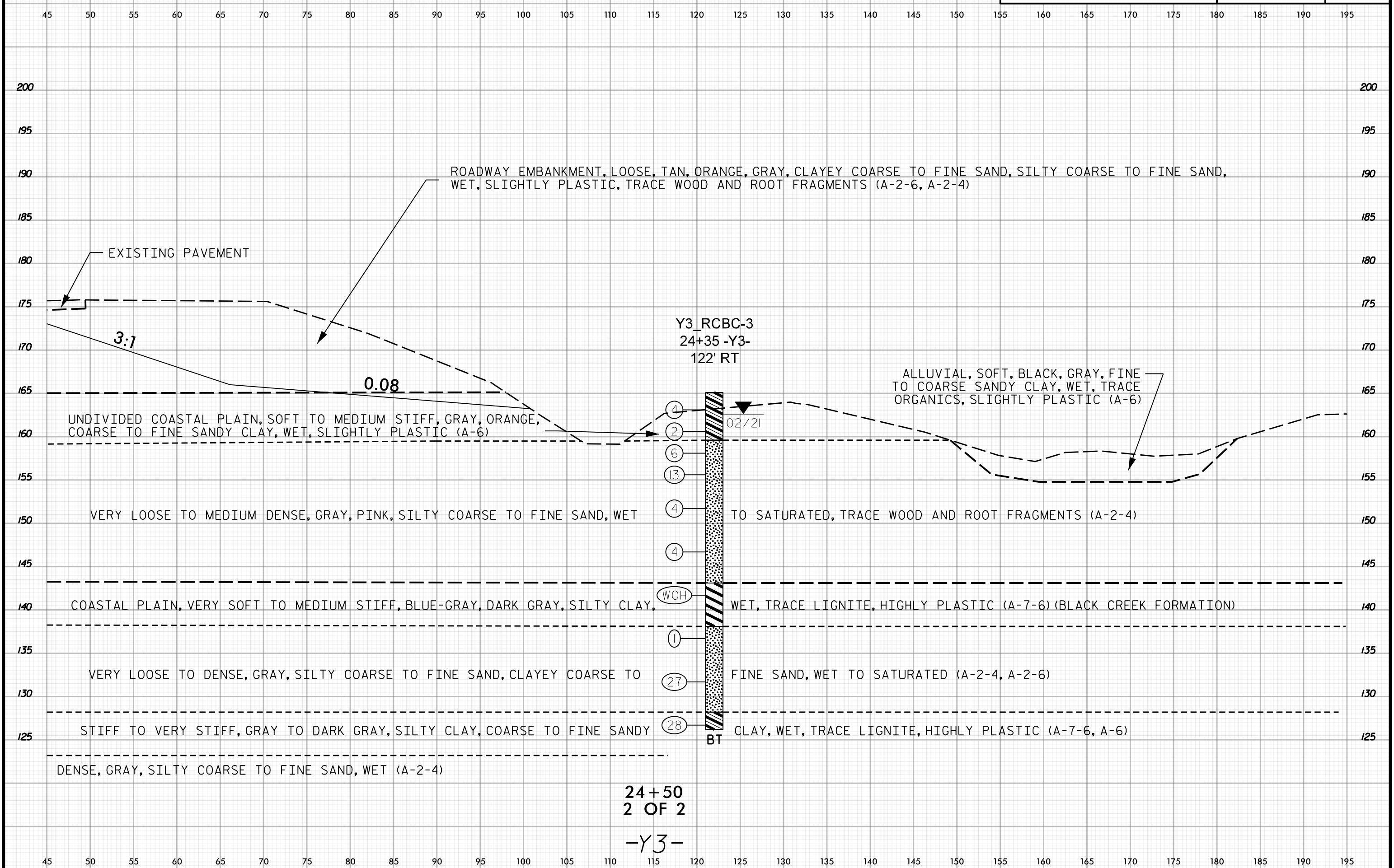
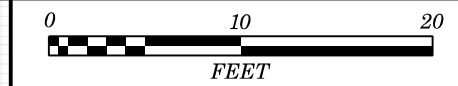

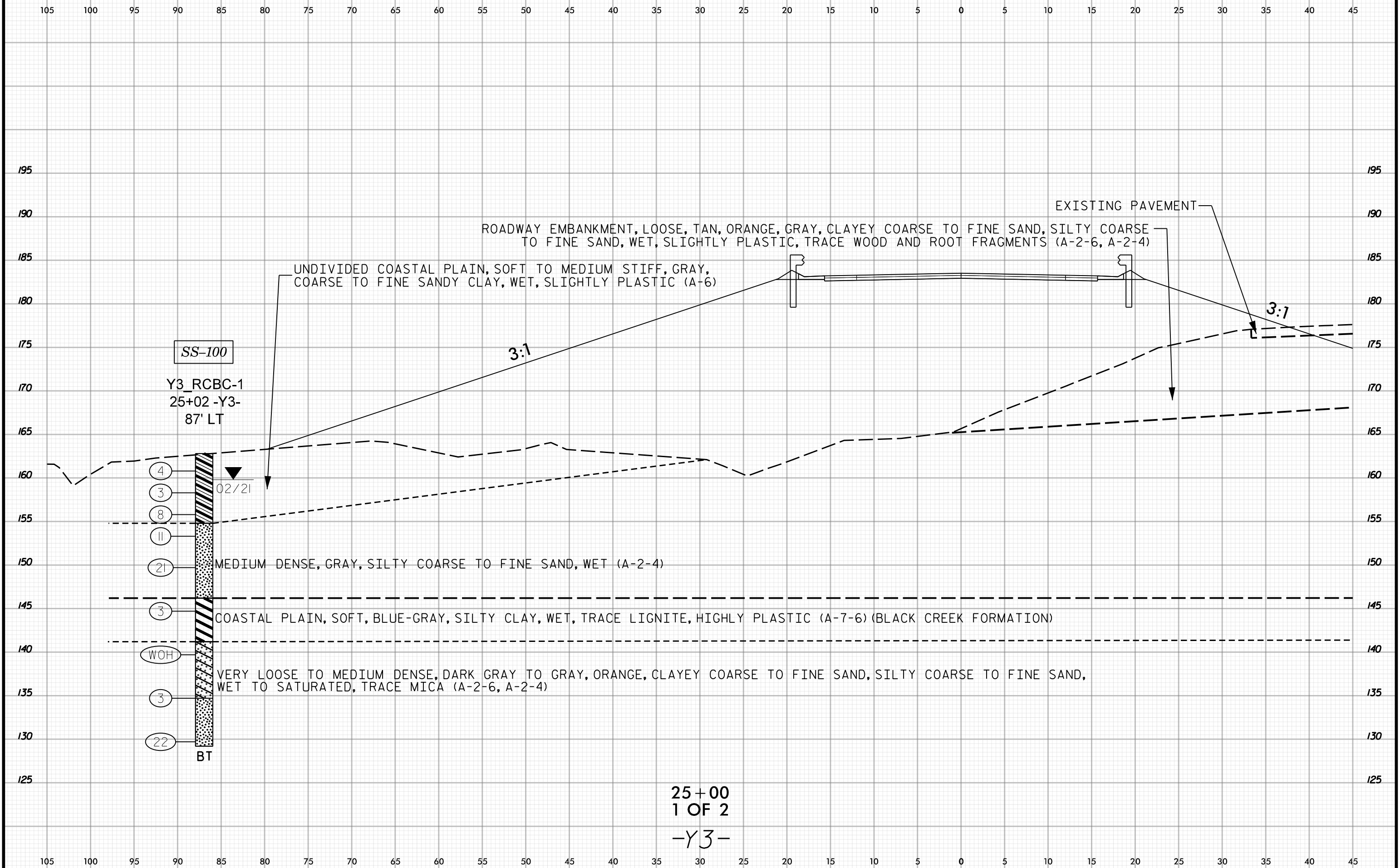

SS-100

Y3_RCBC-1
25+02 -Y3-
87' LT

- 4
- 3
- 8
- 11
- 21
- 3
- WOH
- 3
- 22

BT

UNDIVIDED COASTAL PLAIN, SOFT TO MEDIUM STIFF, GRAY,
COARSE TO FINE SANDY CLAY, WET, SLIGHTLY PLASTIC (A-6)

ROADWAY EMBANKMENT, LOOSE, TAN, ORANGE, GRAY, CLAYEY COARSE TO FINE SAND, SILTY COARSE
TO FINE SAND, WET, SLIGHTLY PLASTIC, TRACE WOOD AND ROOT FRAGMENTS (A-2-6, A-2-4)

EXISTING PAVEMENT

02/21

MEDIUM DENSE, GRAY, SILTY COARSE TO FINE SAND, WET (A-2-4)

COASTAL PLAIN, SOFT, BLUE-GRAY, SILTY CLAY, WET, TRACE LIGNITE, HIGHLY PLASTIC (A-7-6) (BLACK CREEK FORMATION)

VERY LOOSE TO MEDIUM DENSE, DARK GRAY TO GRAY, ORANGE, CLAYEY COARSE TO FINE SAND, SILTY COARSE TO FINE SAND,
WET TO SATURATED, TRACE MICA (A-2-6, A-2-4)

3:1

3:1

25+00
1 OF 2
-Y3-

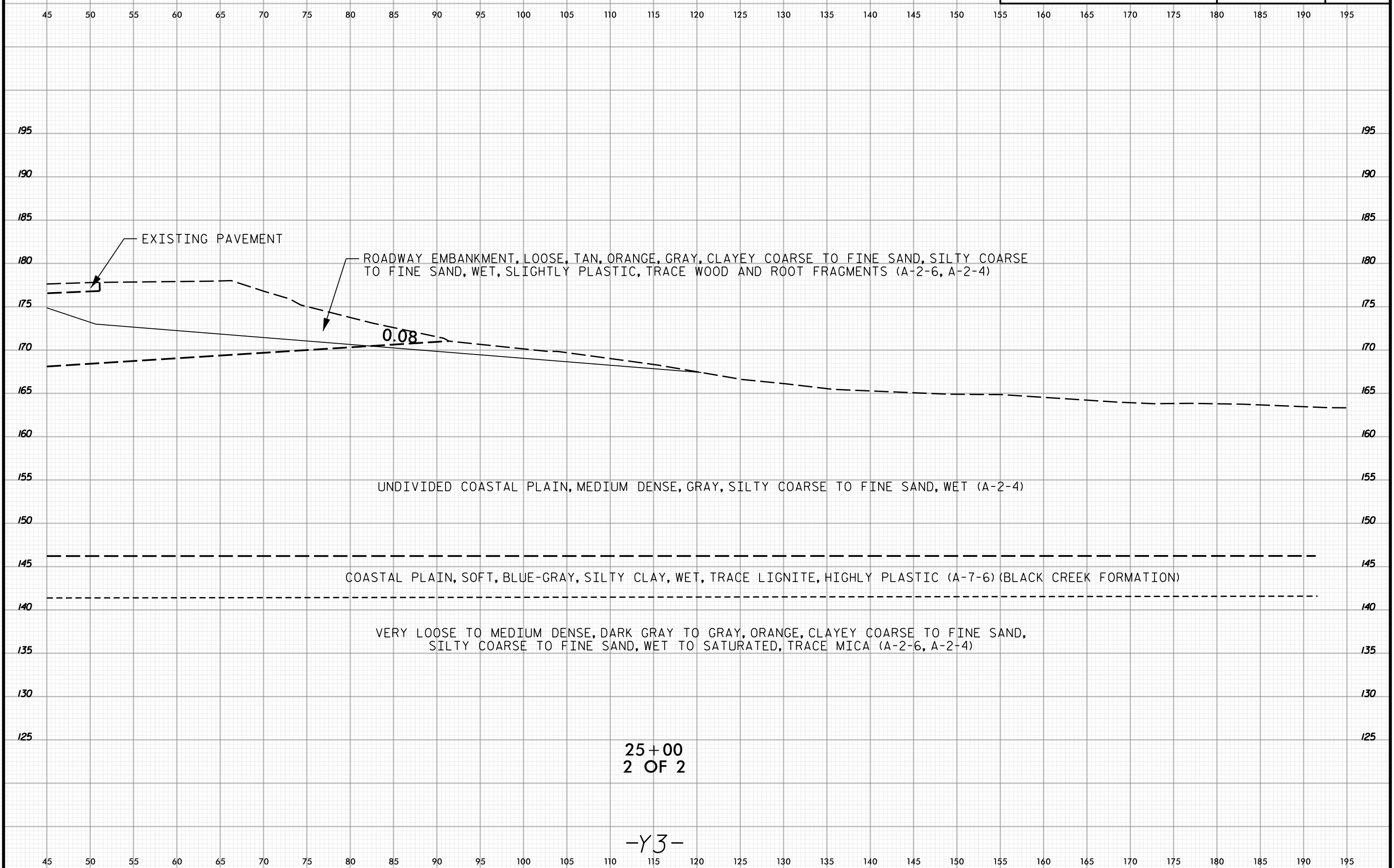

25+00
2 OF 2

-Y3-

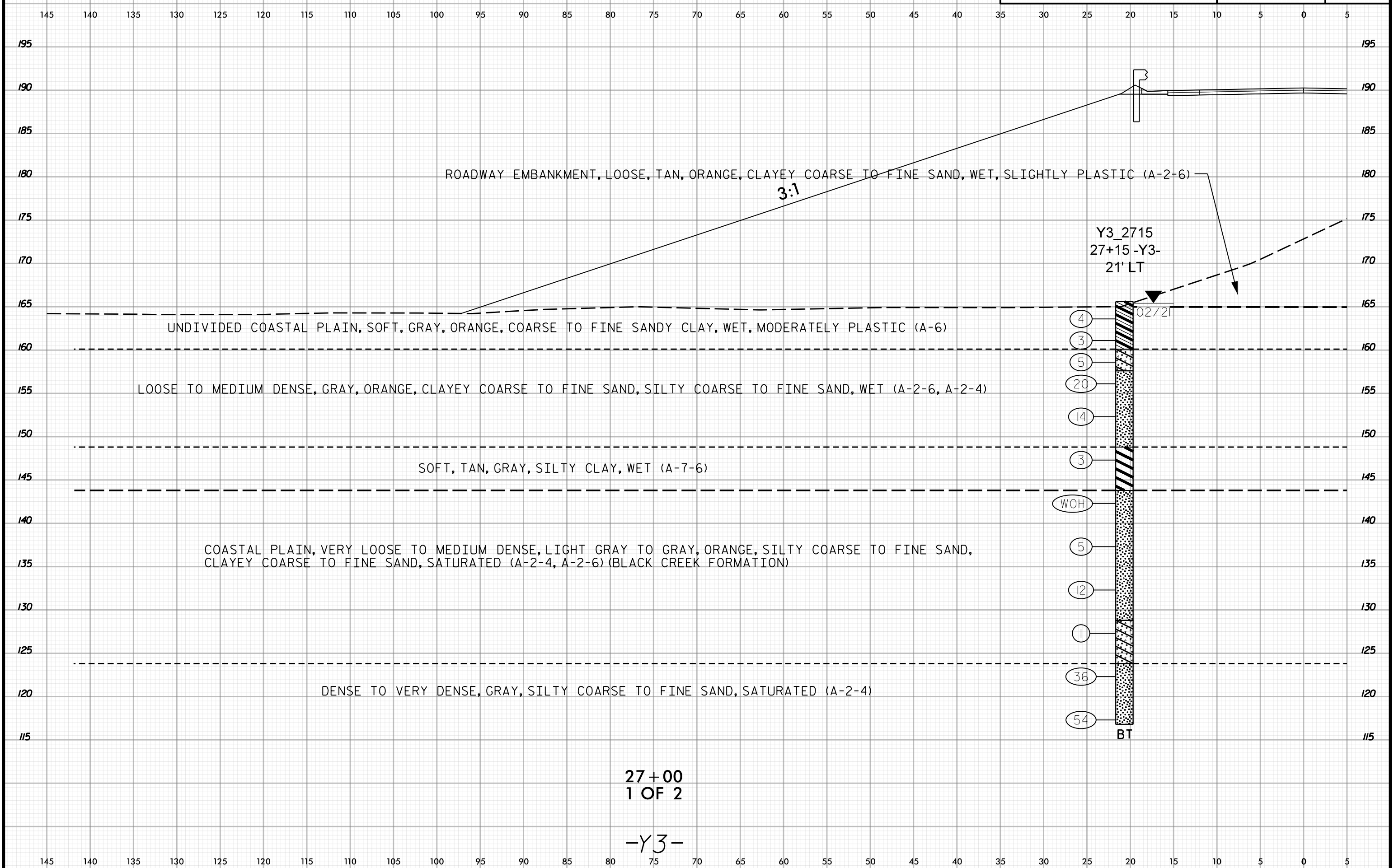
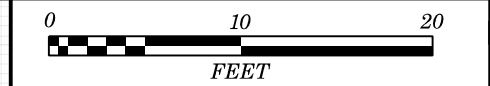

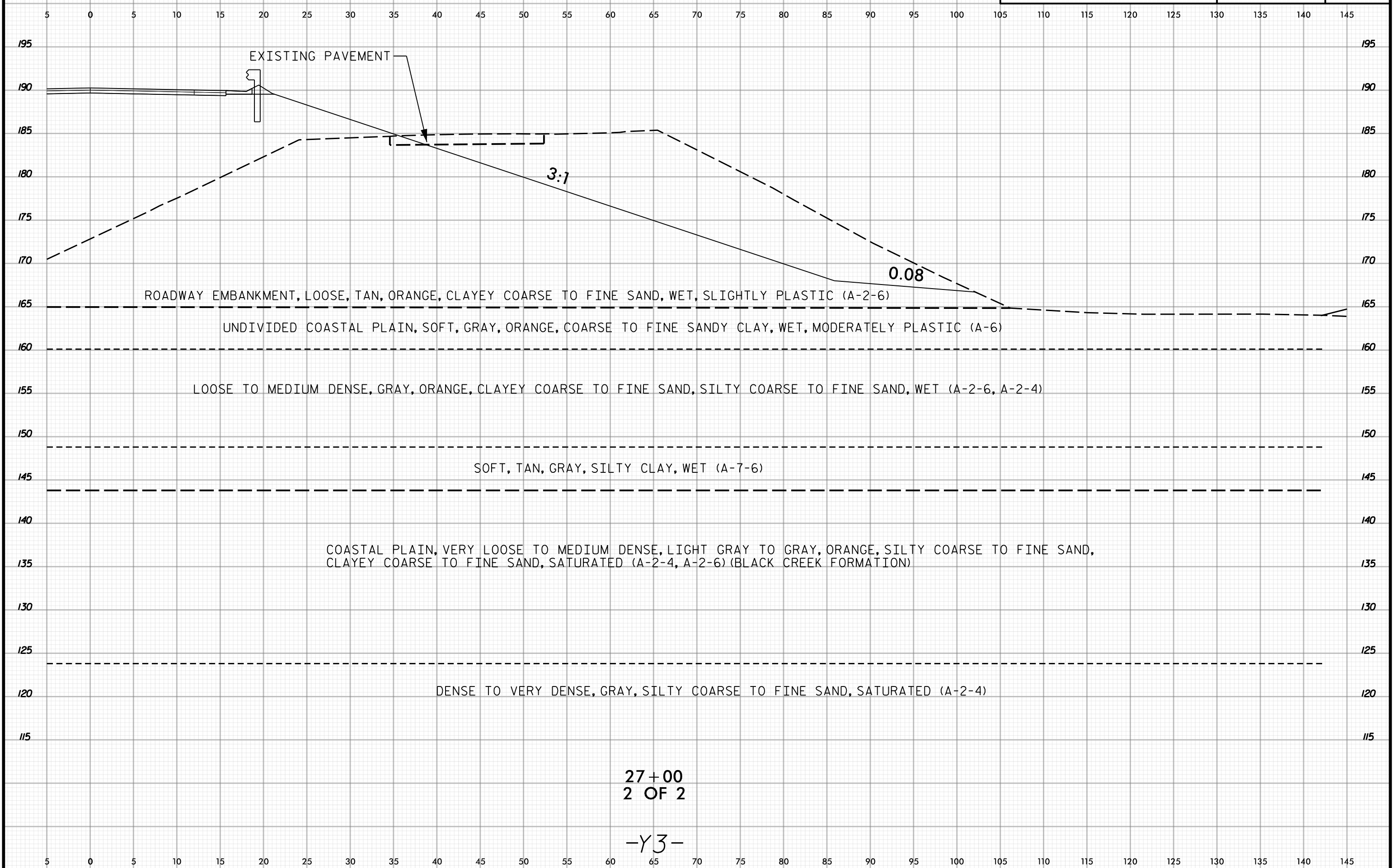

27+00
2 OF 2

-Y3-

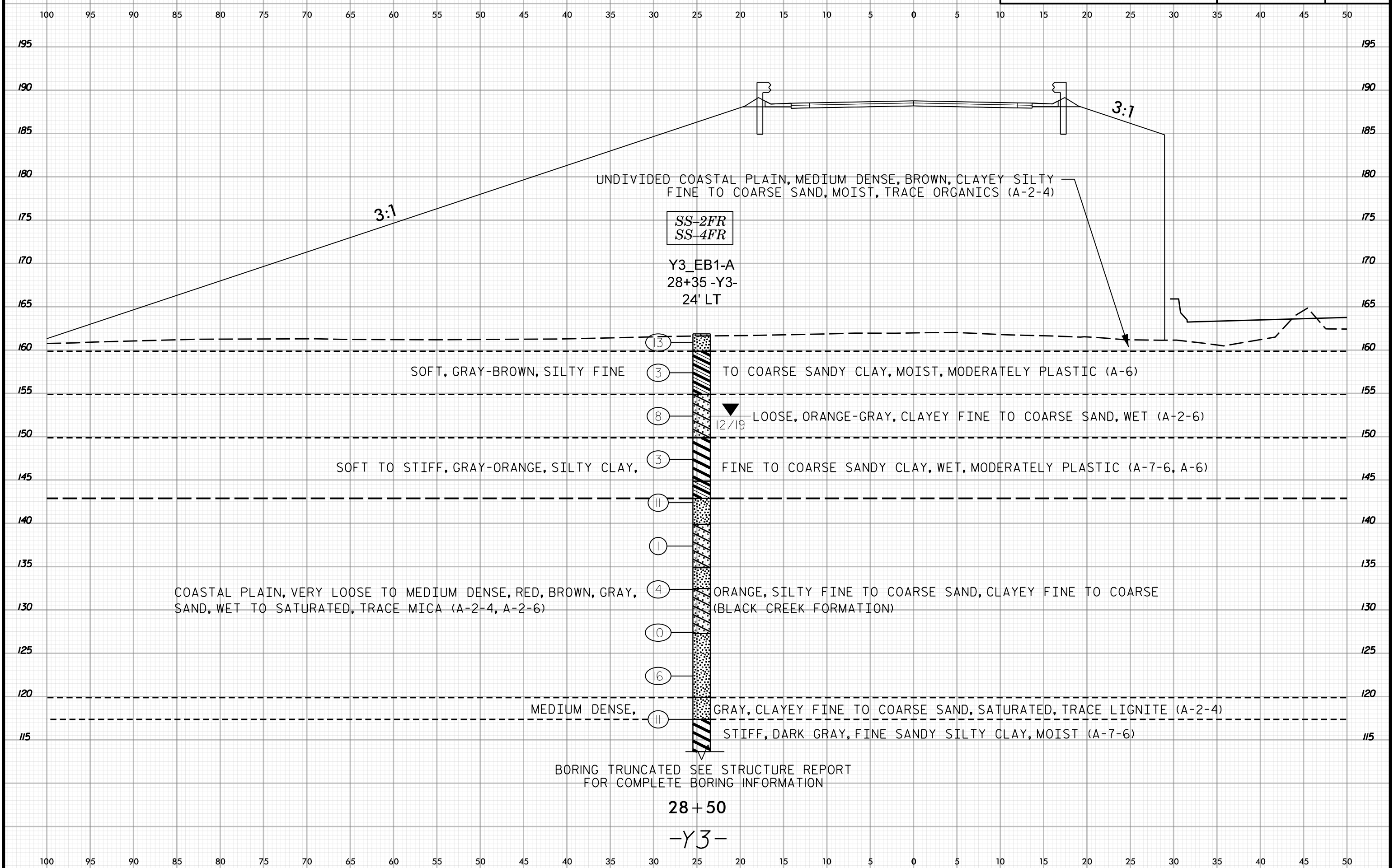
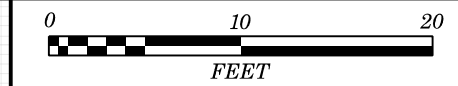

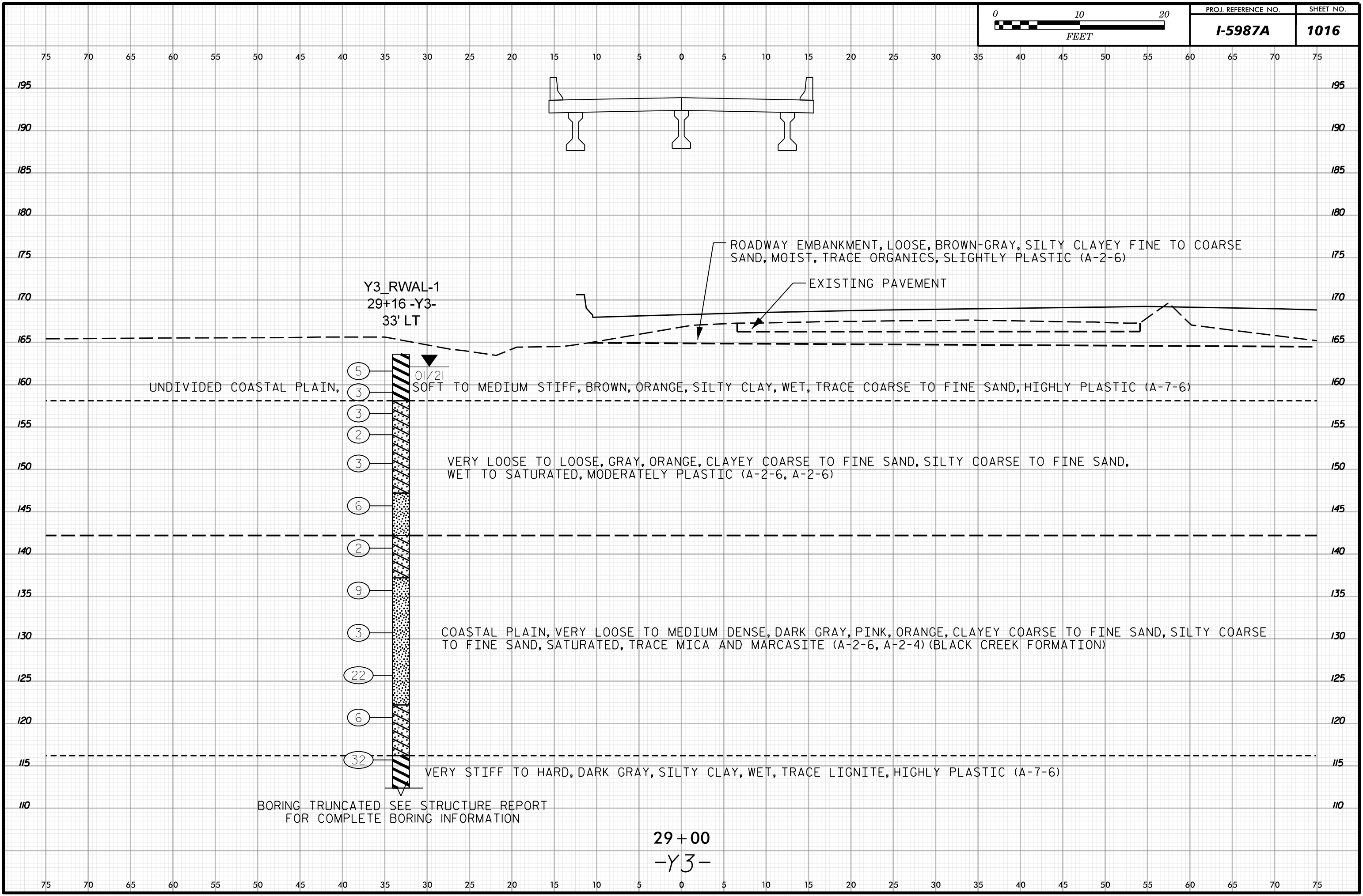

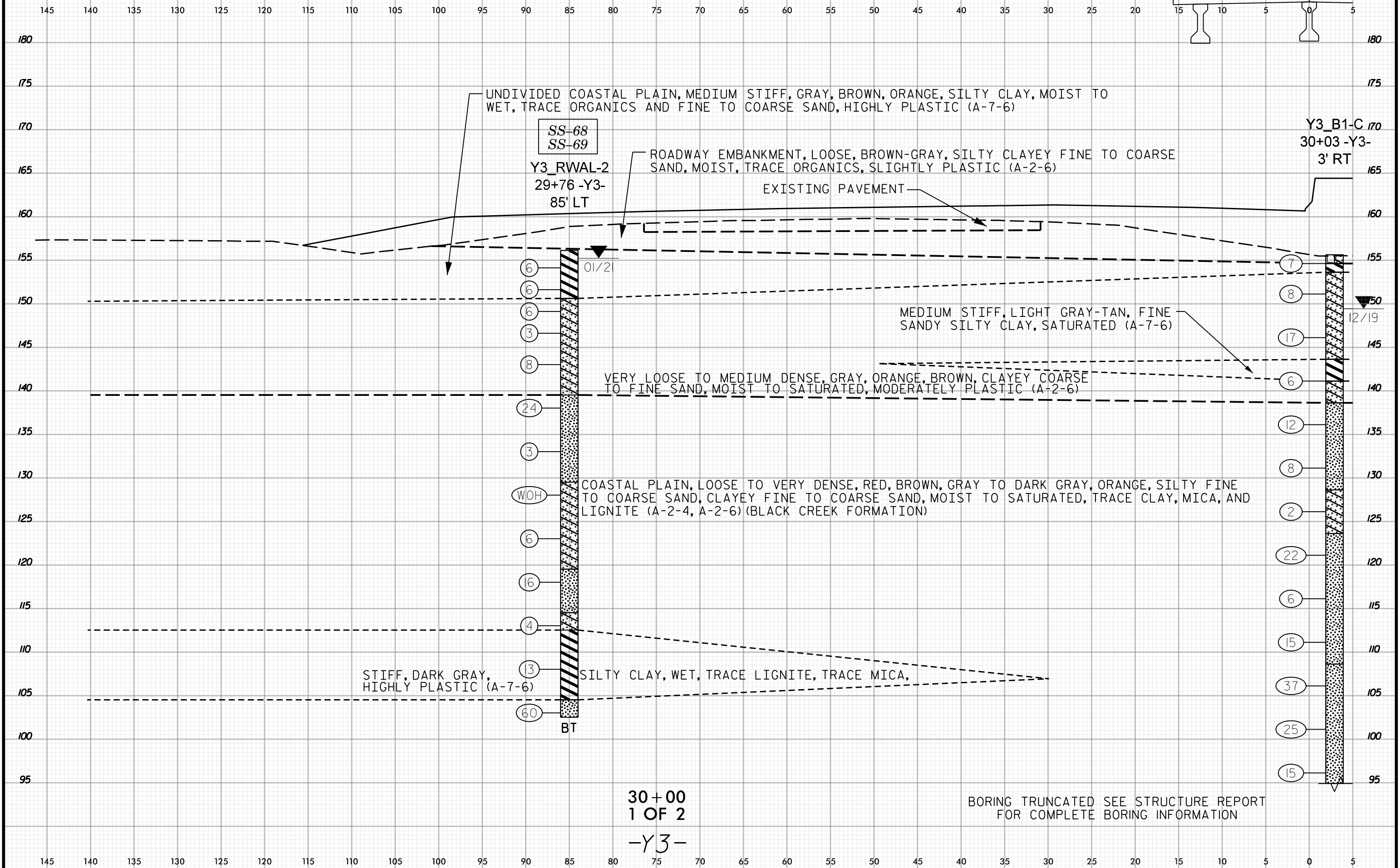
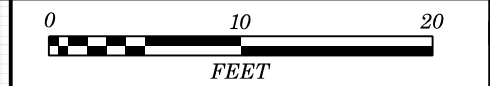

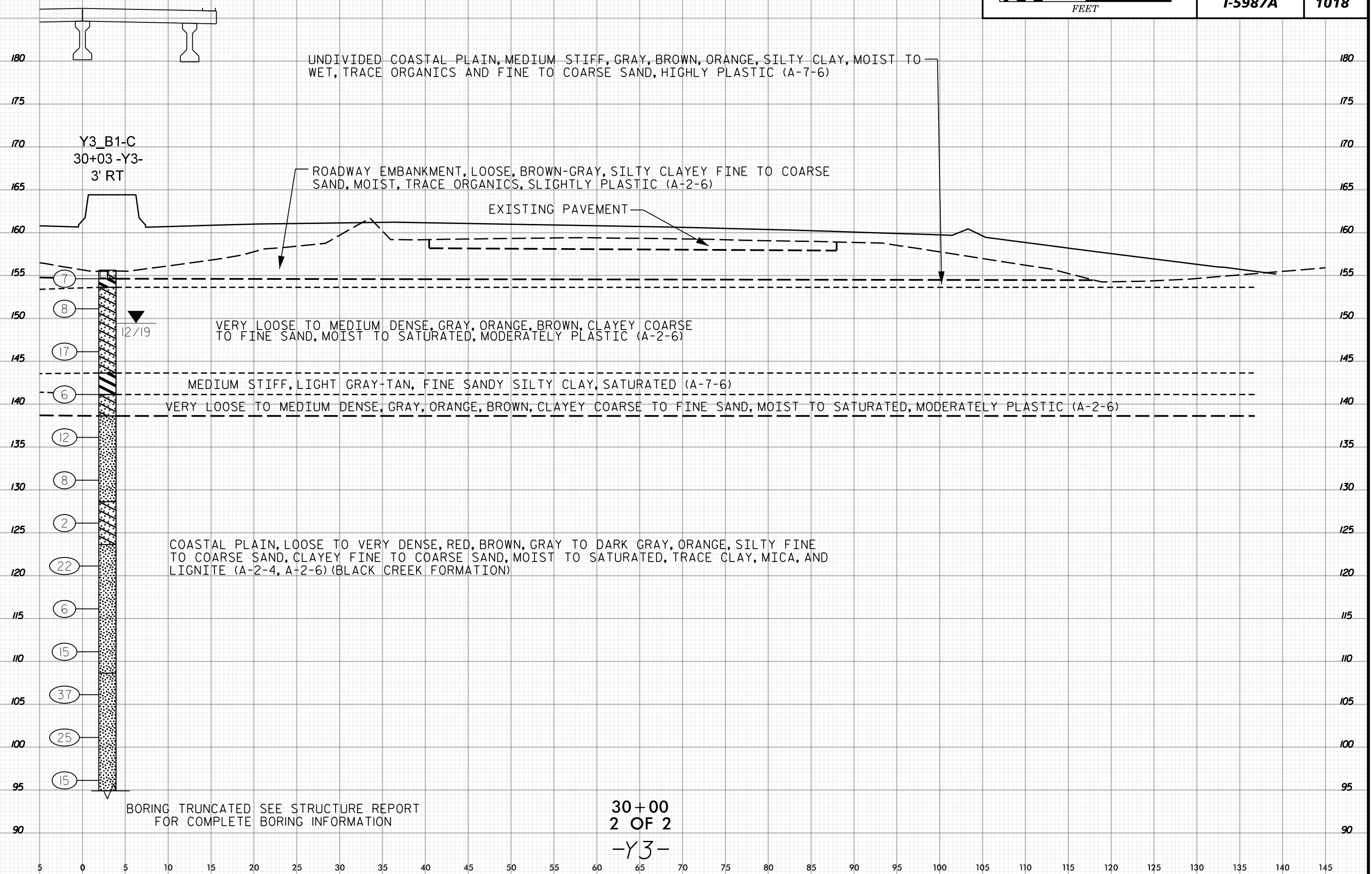
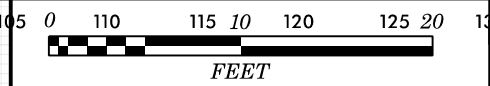

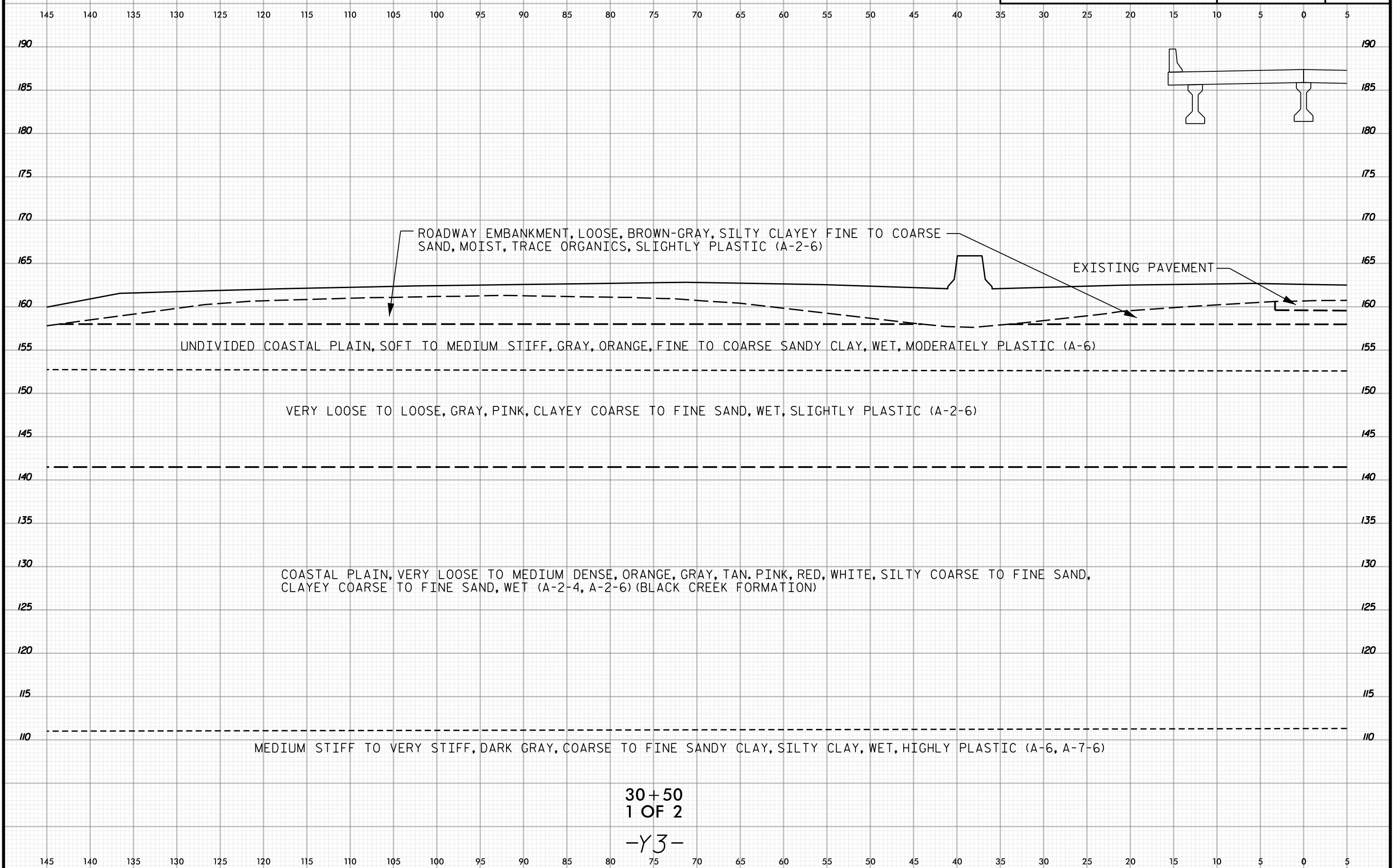

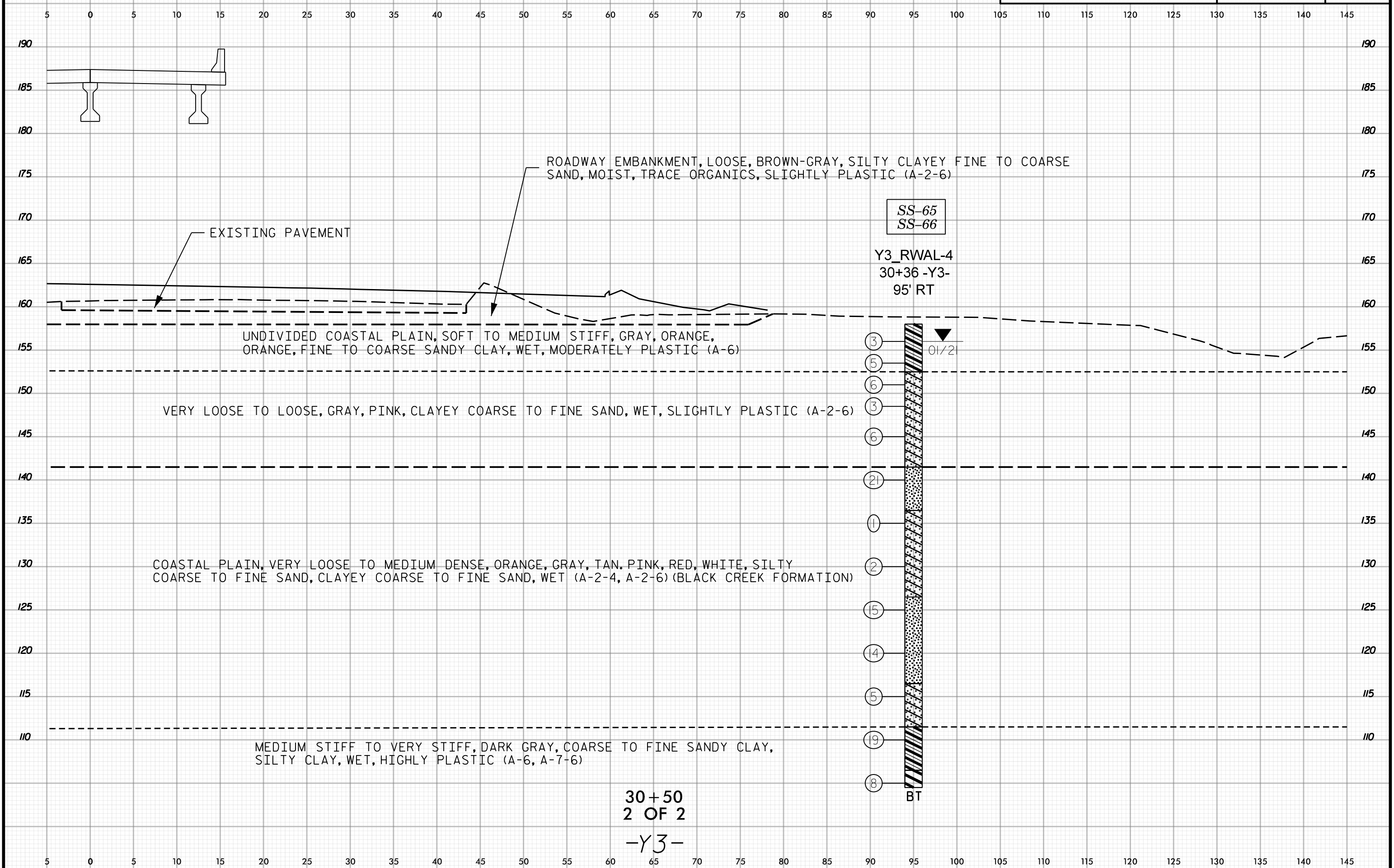

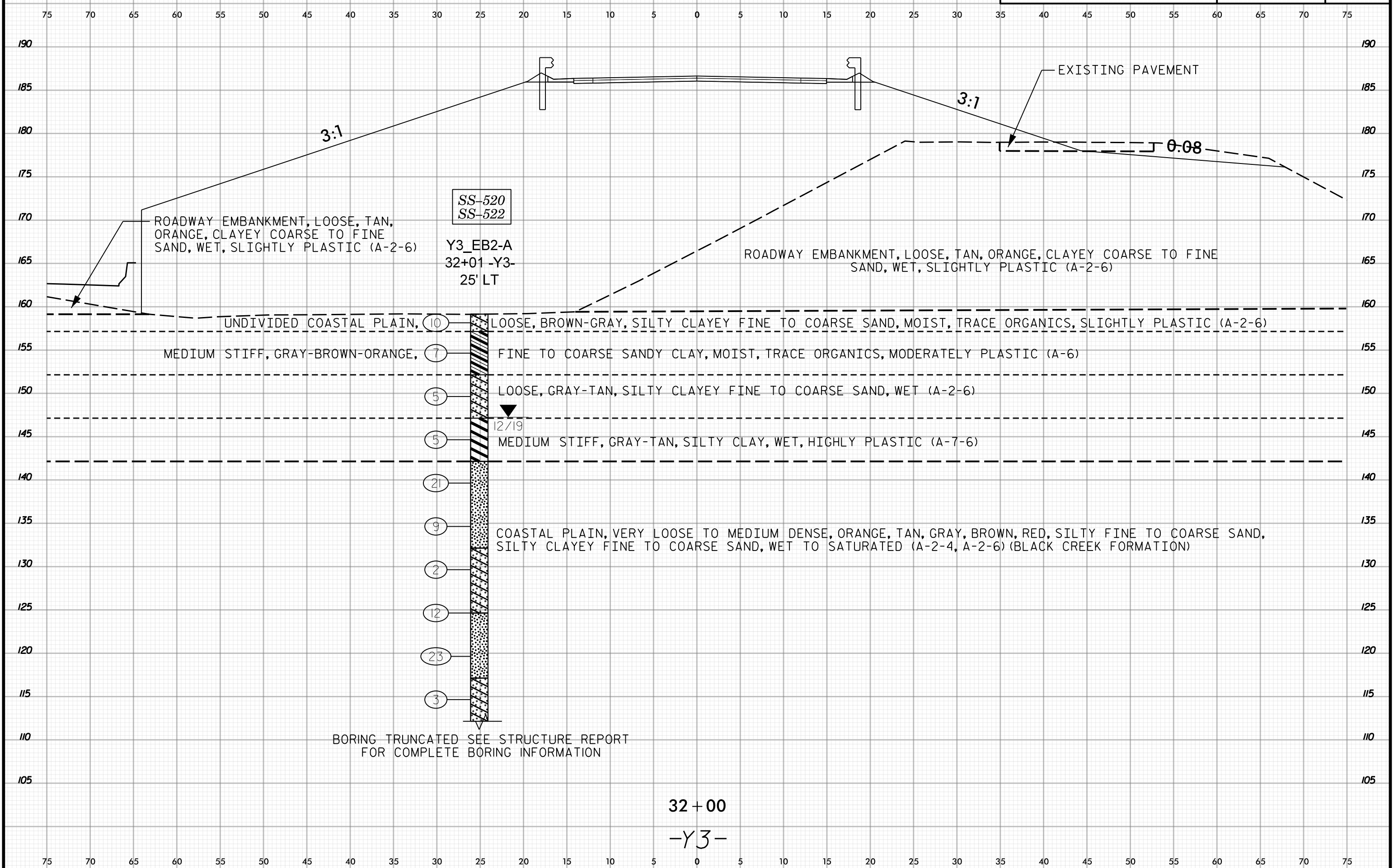
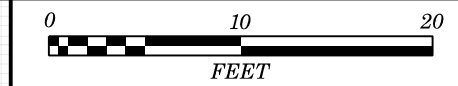

32 + 00
-Y3-

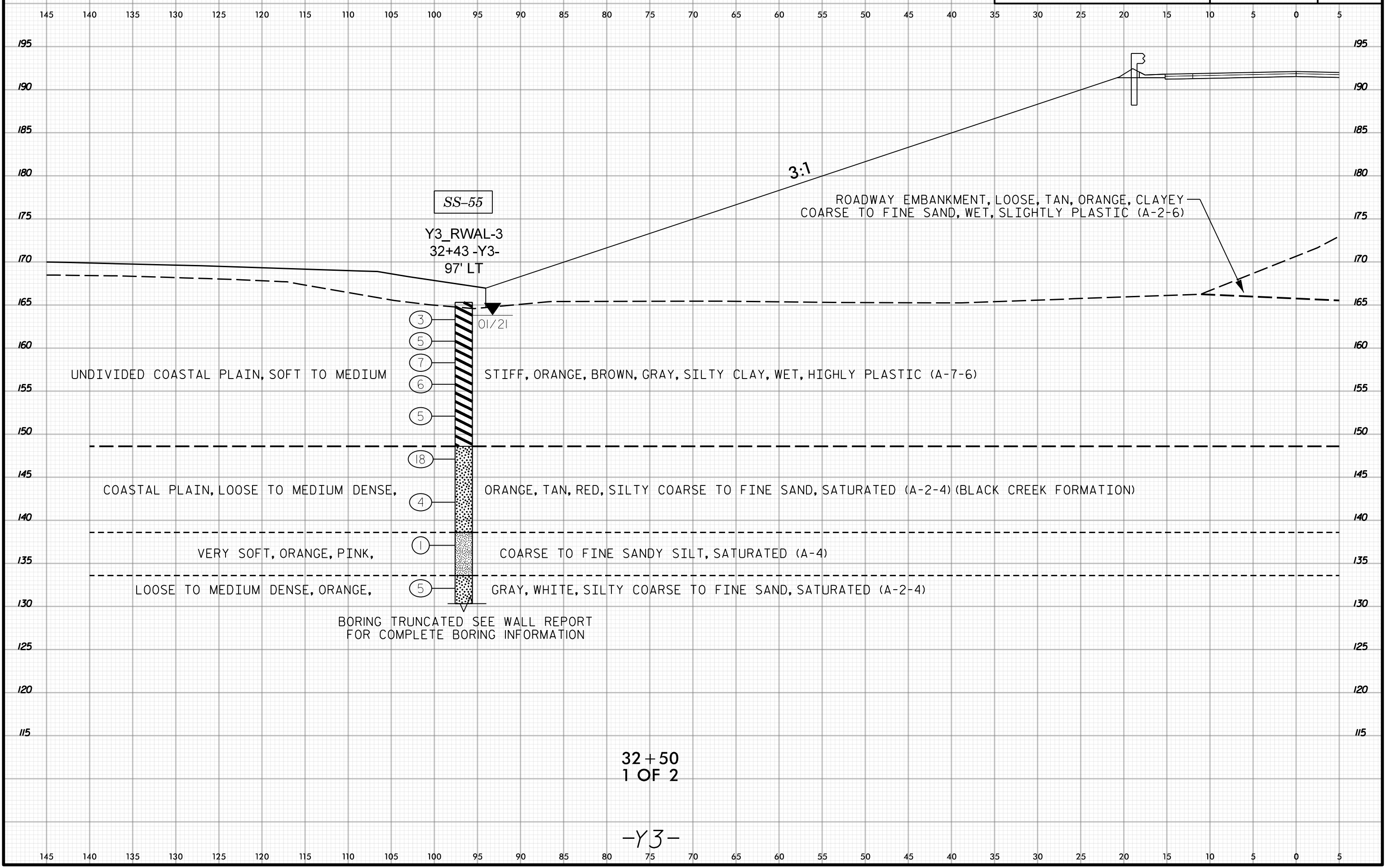

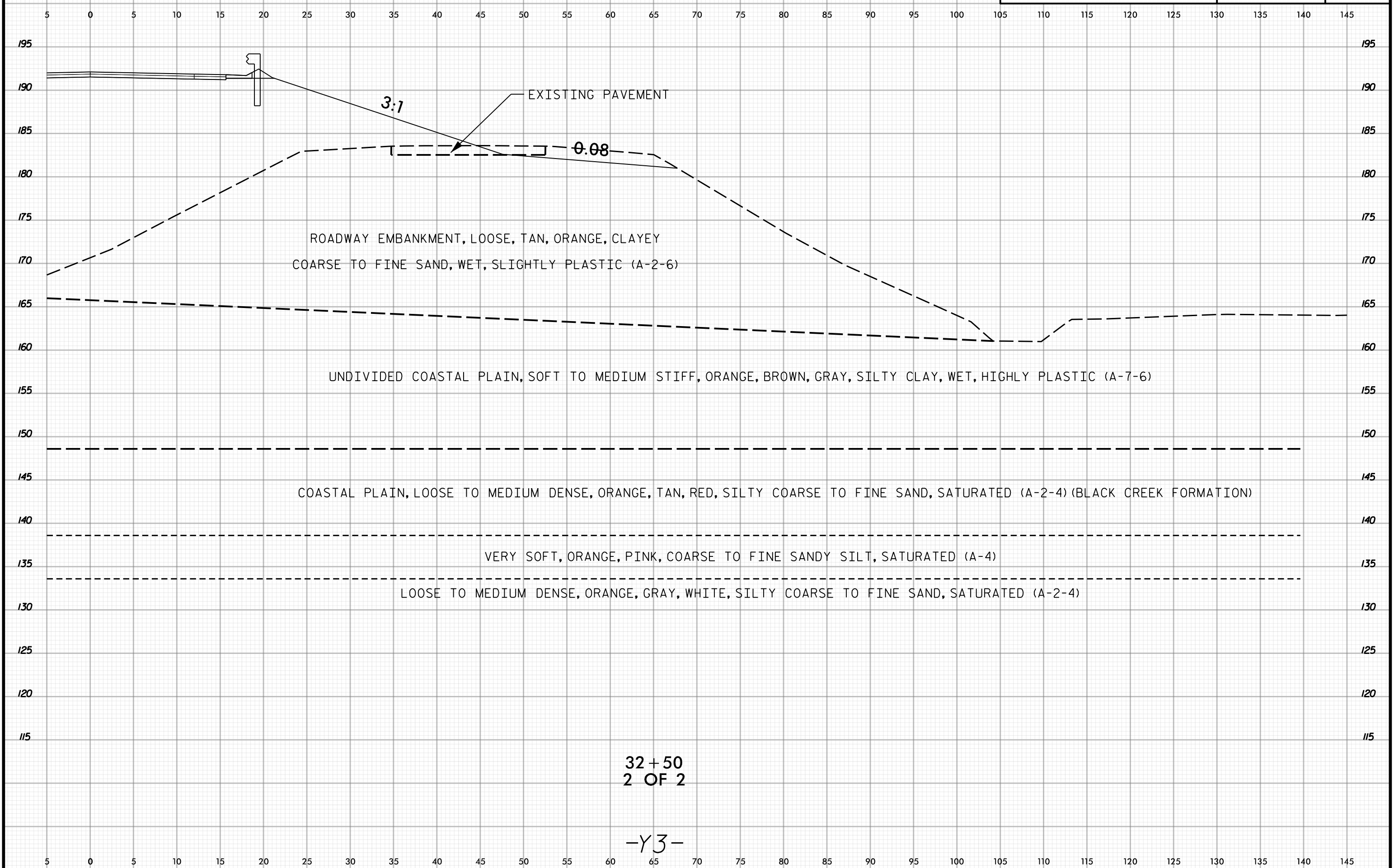

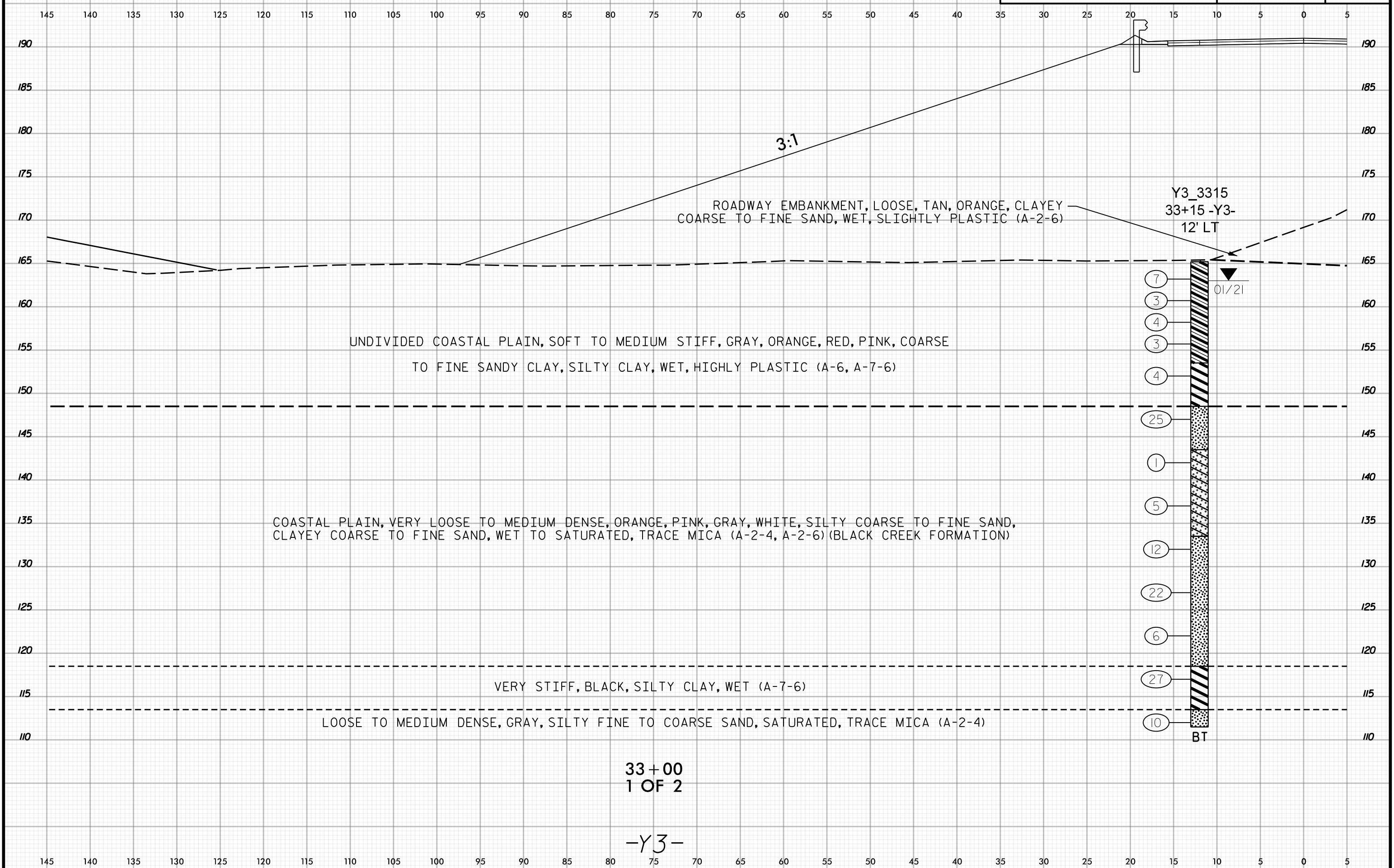
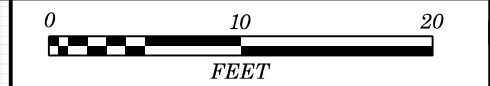

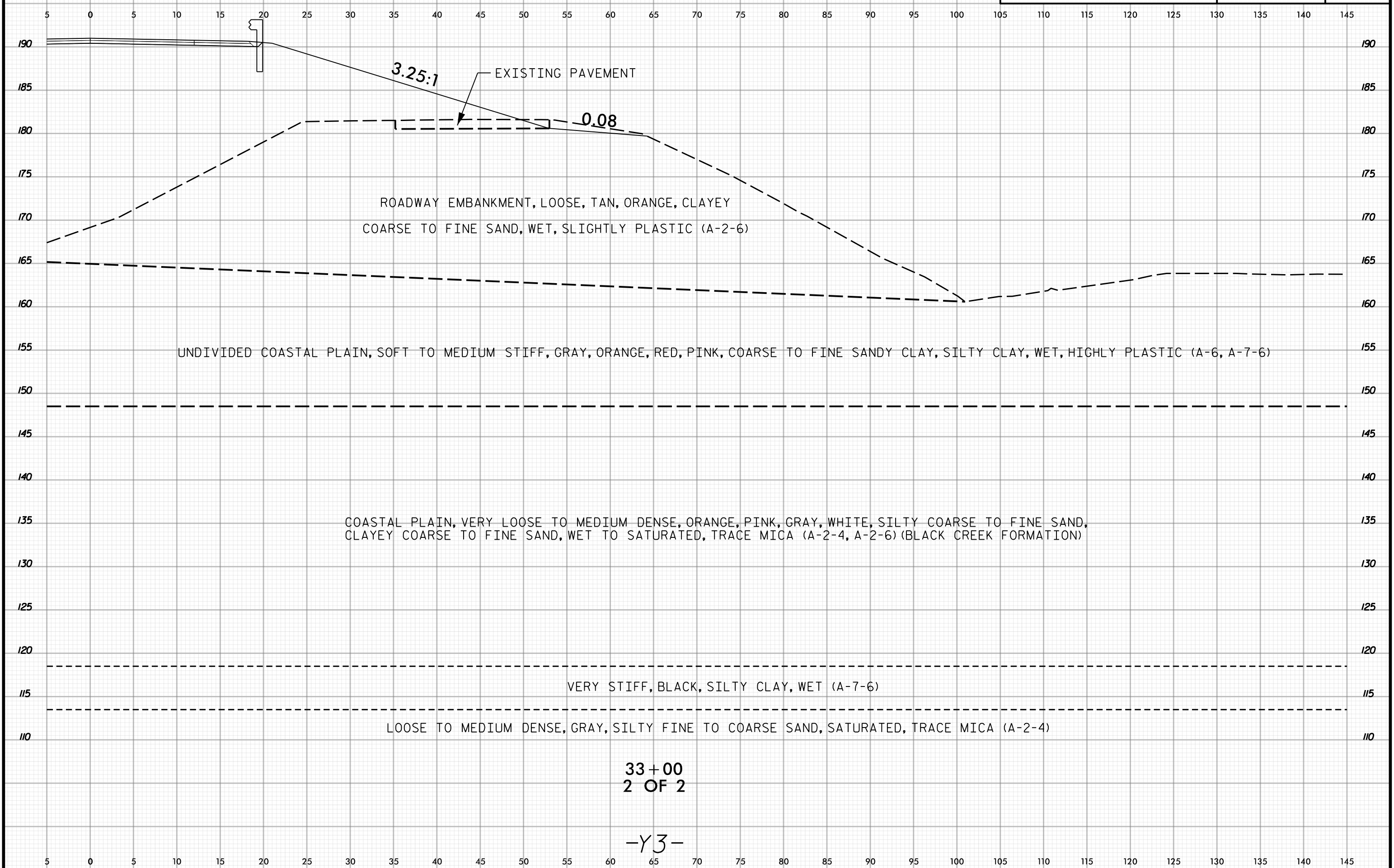

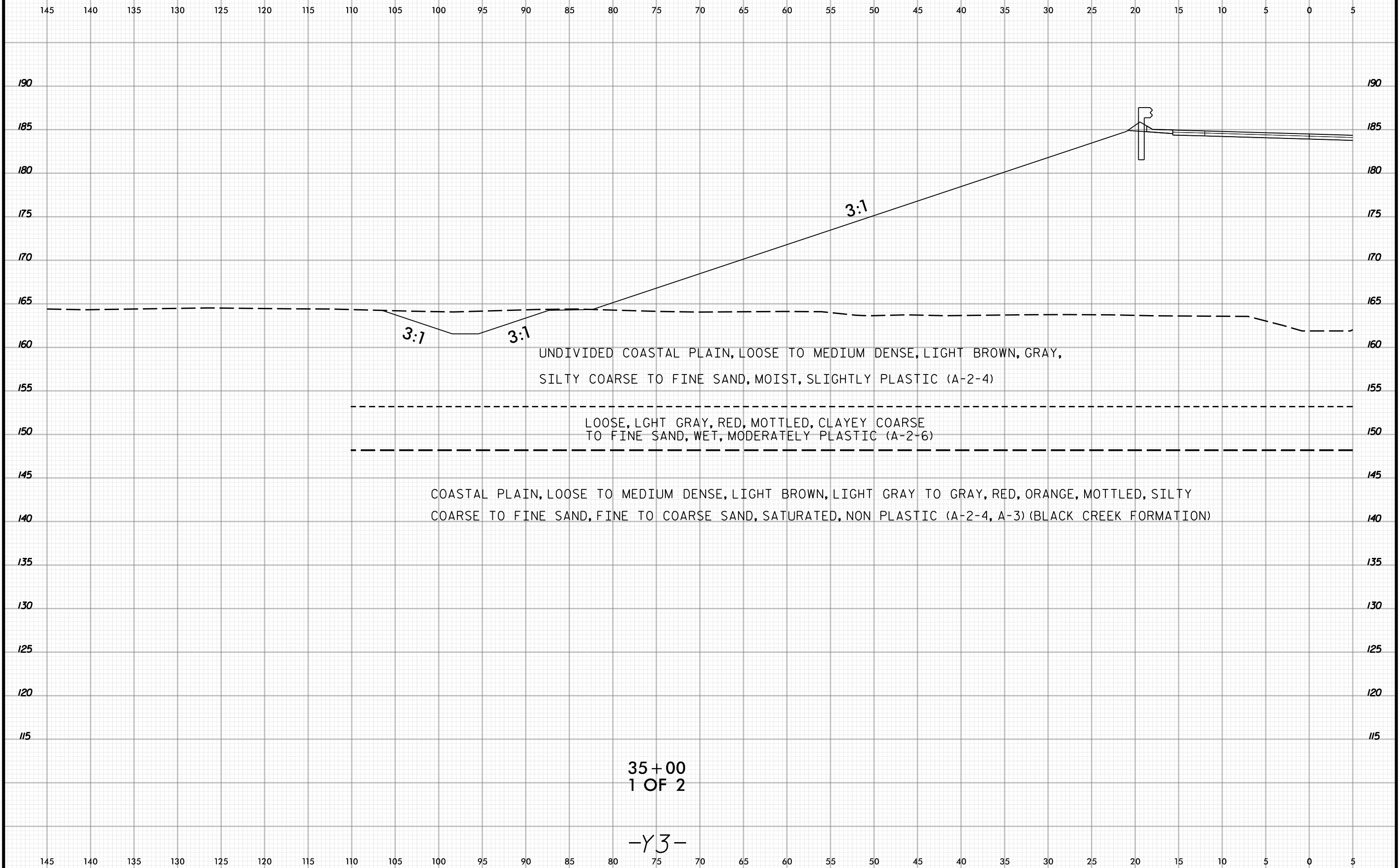

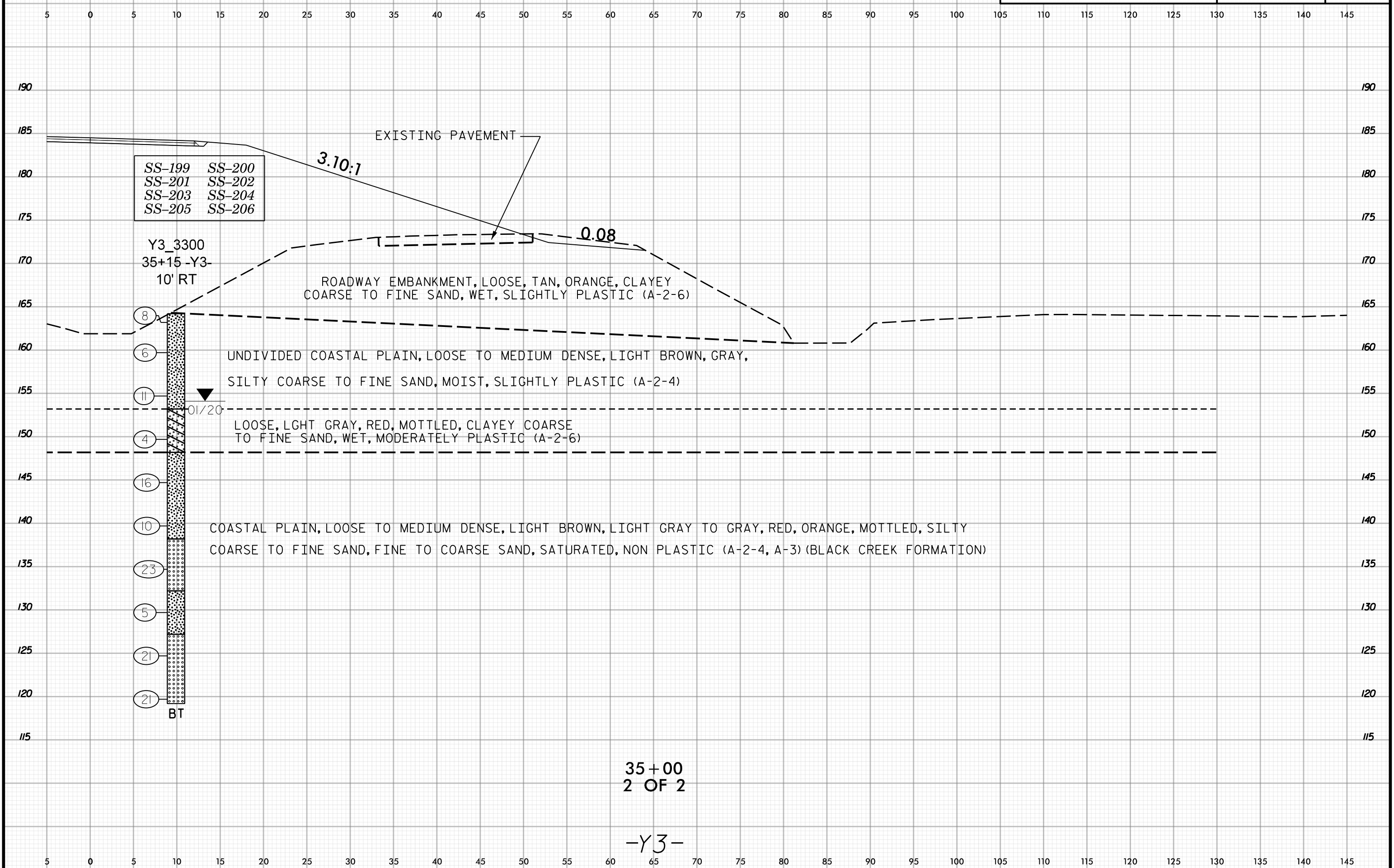

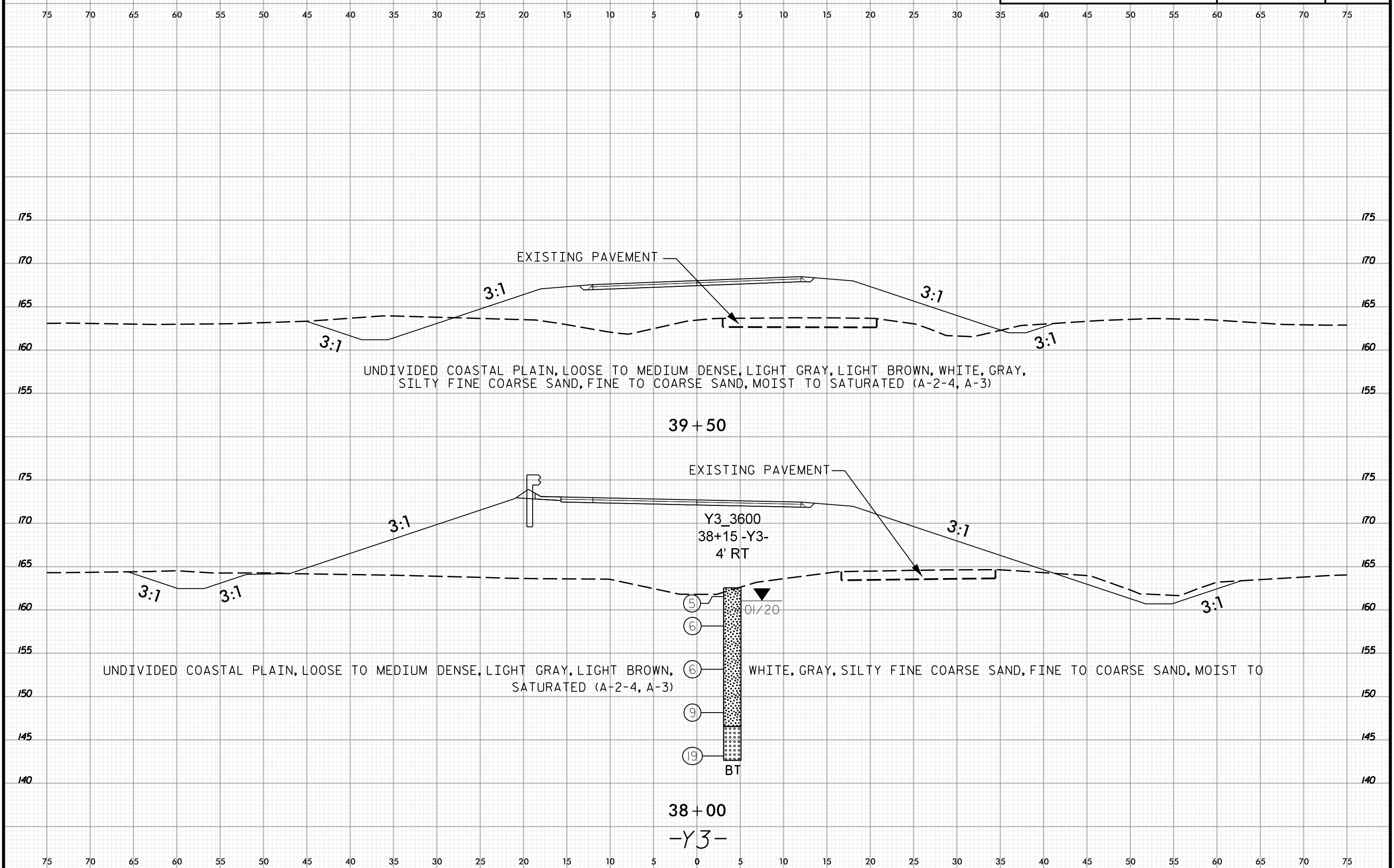
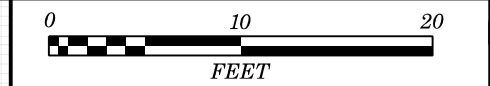



75 70 65 60 55 50 45 40 35 30 25 20 15 10 5 0 5 10 15 20 25 30 35 40 45 50 55 60 65 70 75

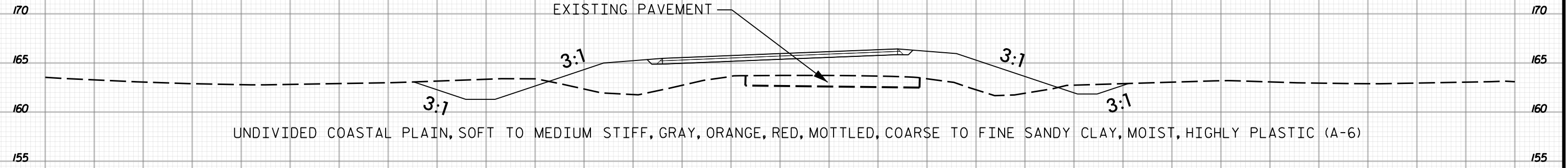

40 + 50

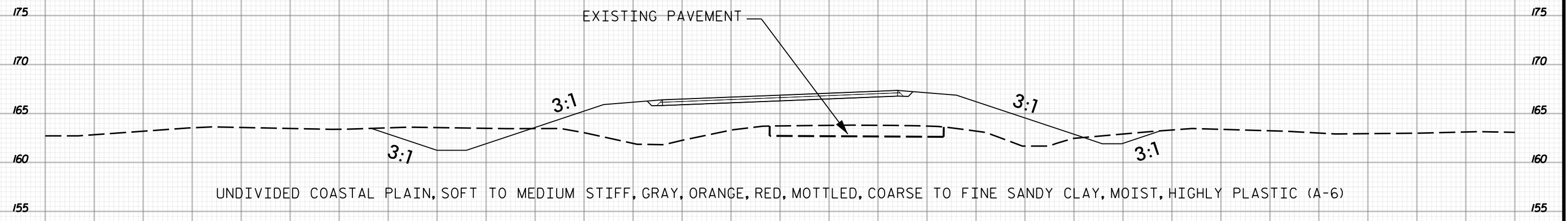

40 + 00

-Y3-

75 70 65 60 55 50 45 40 35 30 25 20 15 10 5 0 5 10 15 20 25 30 35 40 45 50 55 60 65 70 75

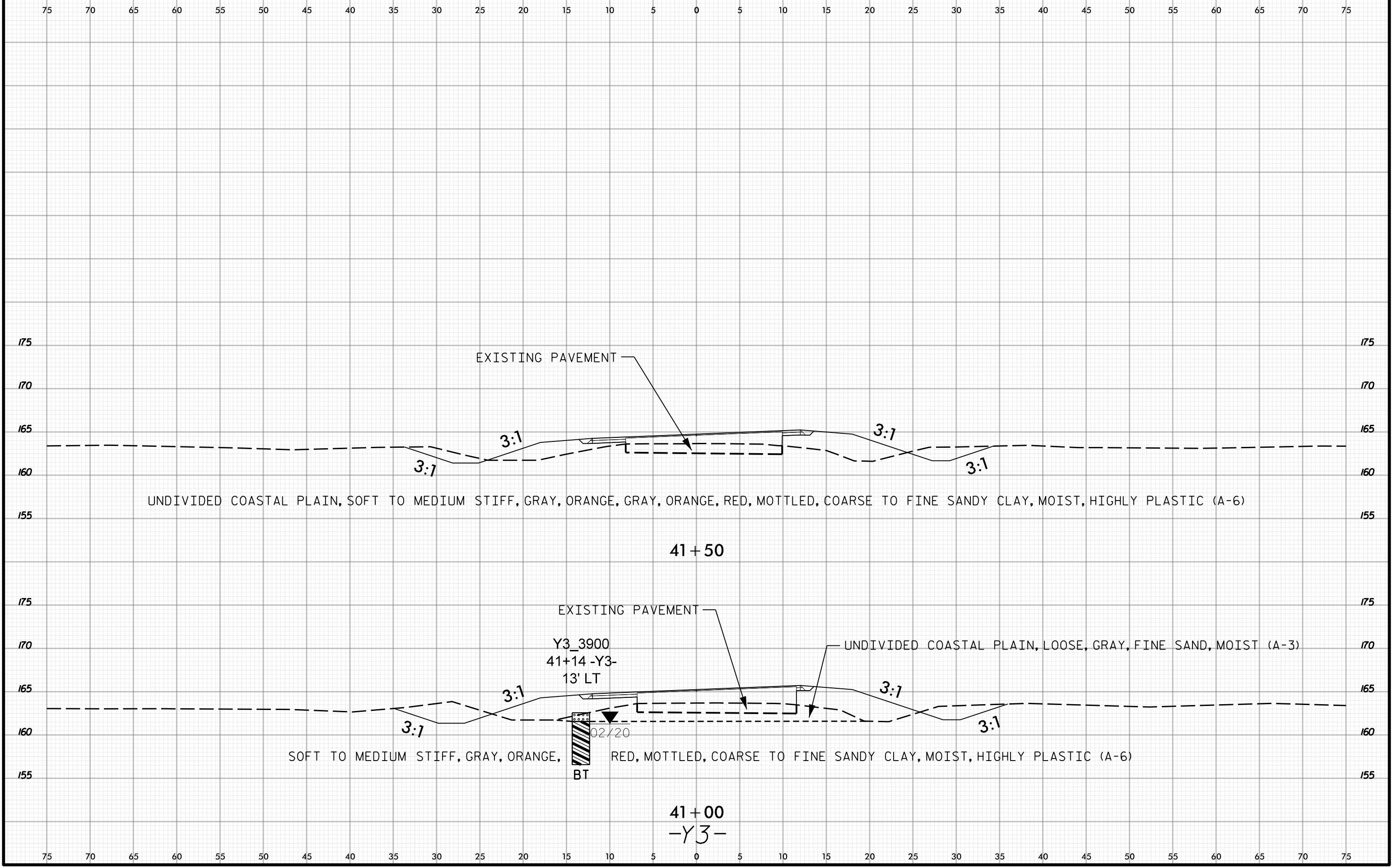



75 70 65 60 55 50 45 40 35 30 25 20 15 10 5 0 5 10 15 20 25 30 35 40 45 50 55 60 65 70 75

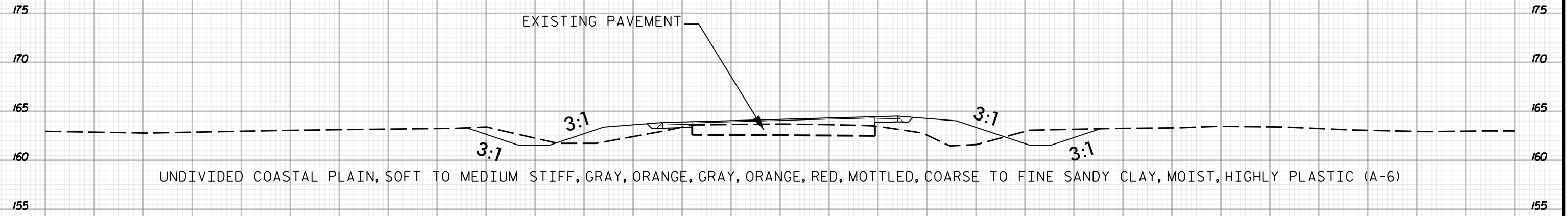

42 + 50

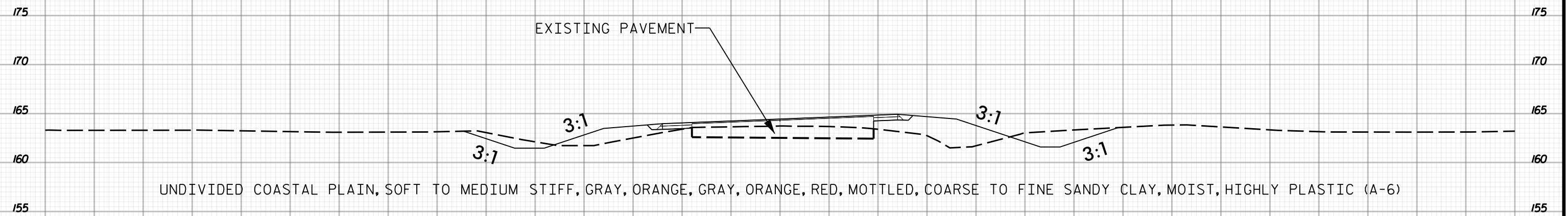

42 + 00
-Y3-

75 70 65 60 55 50 45 40 35 30 25 20 15 10 5 0 5 10 15 20 25 30 35 40 45 50 55 60 65 70 75

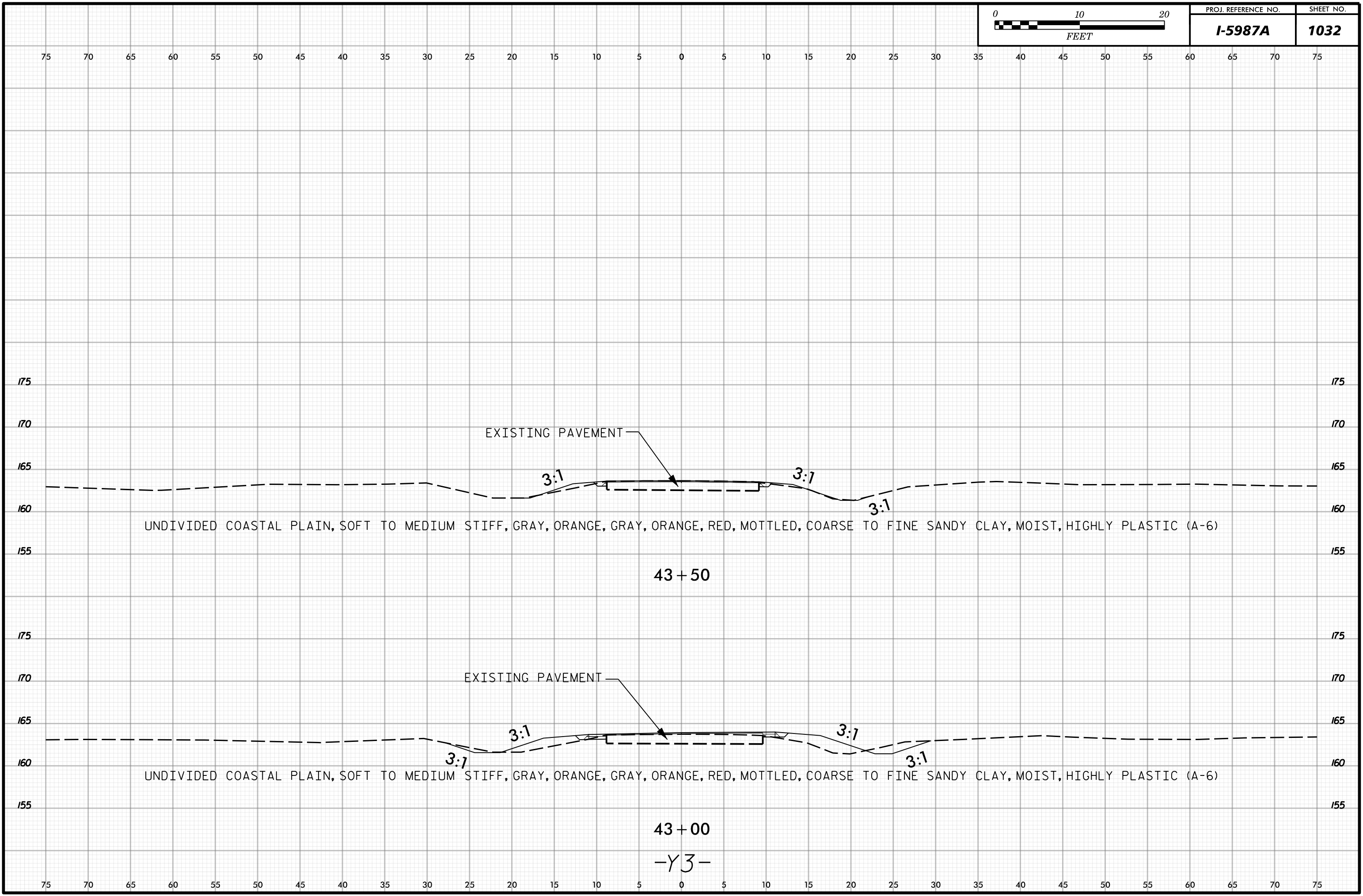

UNDIVIDED COASTAL PLAIN, SOFT TO MEDIUM STIFF, GRAY, ORANGE, GRAY, ORANGE, RED, MOTTLED, COARSE TO FINE SANDY CLAY, MOIST, HIGHLY PLASTIC (A-6)

43 + 50

UNDIVIDED COASTAL PLAIN, SOFT TO MEDIUM STIFF, GRAY, ORANGE, GRAY, ORANGE, RED, MOTTLED, COARSE TO FINE SANDY CLAY, MOIST, HIGHLY PLASTIC (A-6)

43 + 00

-Y3-

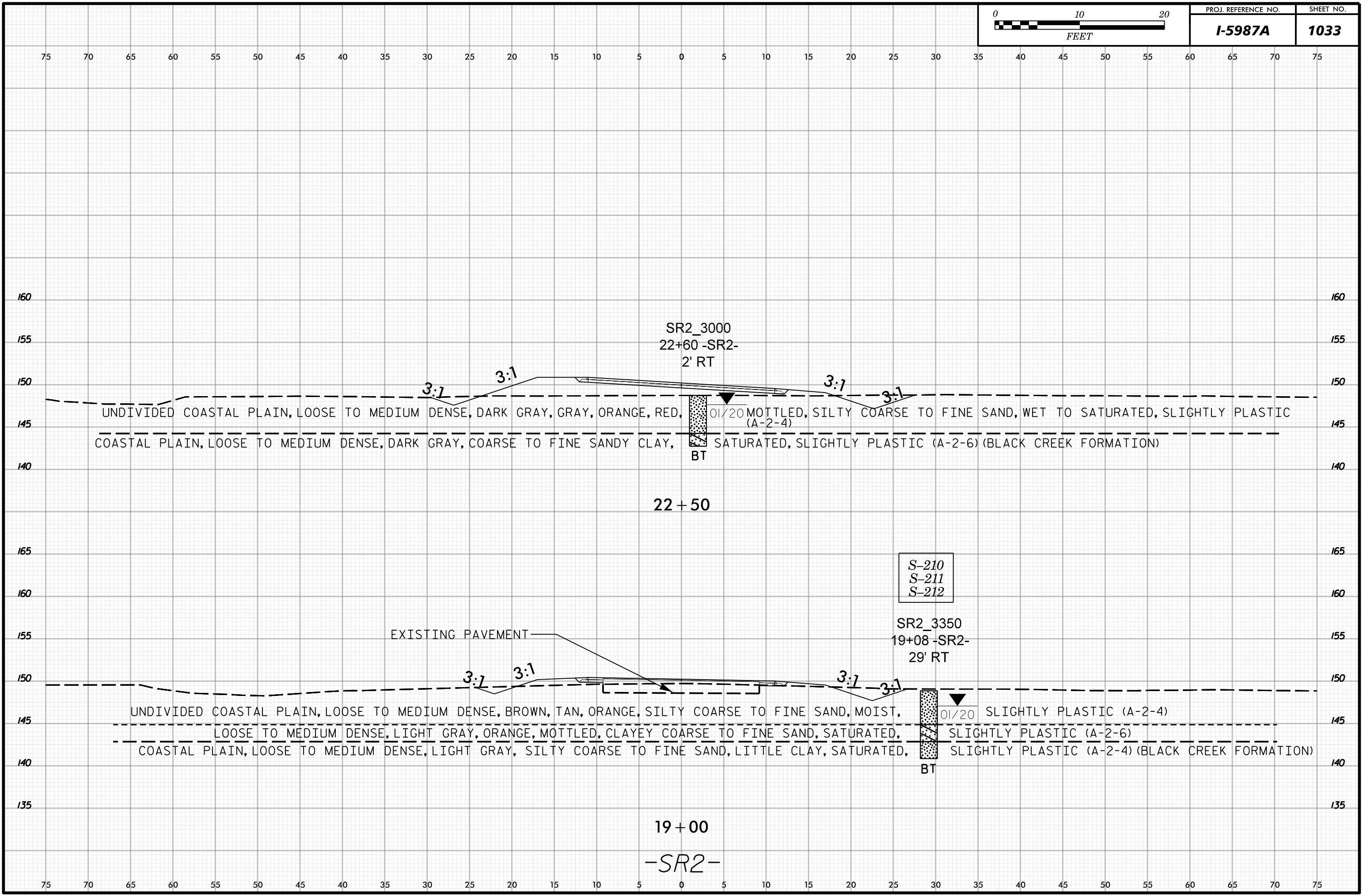
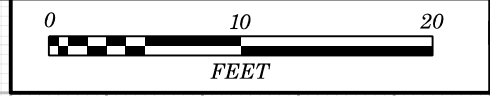

SR2_3000
22+60 -SR2-
2' RT

UNDIVIDED COASTAL PLAIN, LOOSE TO MEDIUM DENSE, DARK GRAY, GRAY, ORANGE, RED, 01/20 MOTTLED, SILTY COARSE TO FINE SAND, WET TO SATURATED, SLIGHTLY PLASTIC (A-2-4)
COASTAL PLAIN, LOOSE TO MEDIUM DENSE, DARK GRAY, COARSE TO FINE SANDY CLAY, SATURATED, SLIGHTLY PLASTIC (A-2-6) (BLACK CREEK FORMATION)

22 + 50

S-210
S-211
S-212

SR2_3350
19+08 -SR2-
29' RT

EXISTING PAVEMENT

UNDIVIDED COASTAL PLAIN, LOOSE TO MEDIUM DENSE, BROWN, TAN, ORANGE, SILTY COARSE TO FINE SAND, MOIST, 01/20 SLIGHTLY PLASTIC (A-2-4)
LOOSE TO MEDIUM DENSE, LIGHT GRAY, ORANGE, MOTTLED, CLAYEY COARSE TO FINE SAND, SATURATED, SLIGHTLY PLASTIC (A-2-6)
COASTAL PLAIN, LOOSE TO MEDIUM DENSE, LIGHT GRAY, SILTY COARSE TO FINE SAND, LITTLE CLAY, SATURATED, SLIGHTLY PLASTIC (A-2-4) (BLACK CREEK FORMATION)

19 + 00
-SR2-

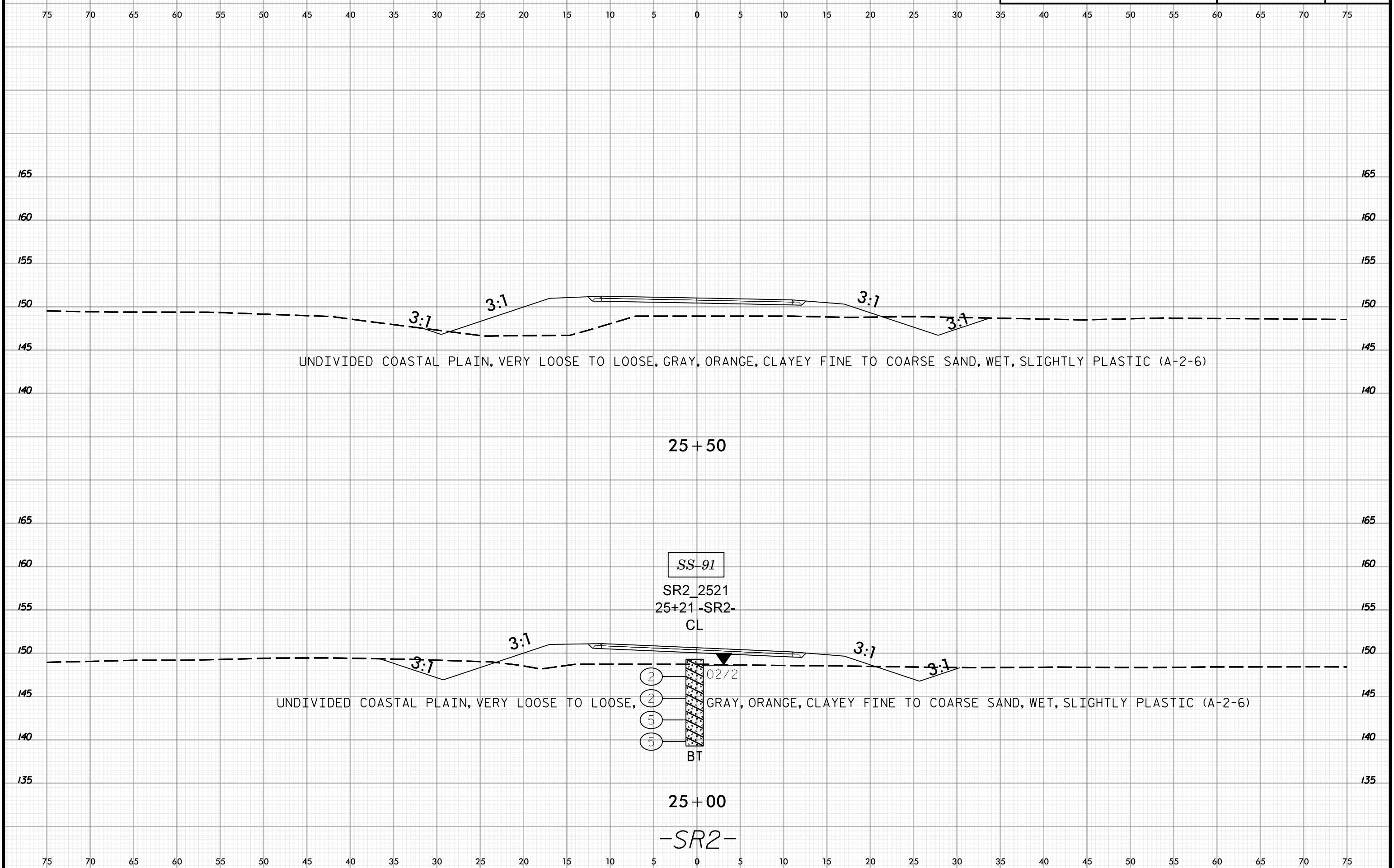

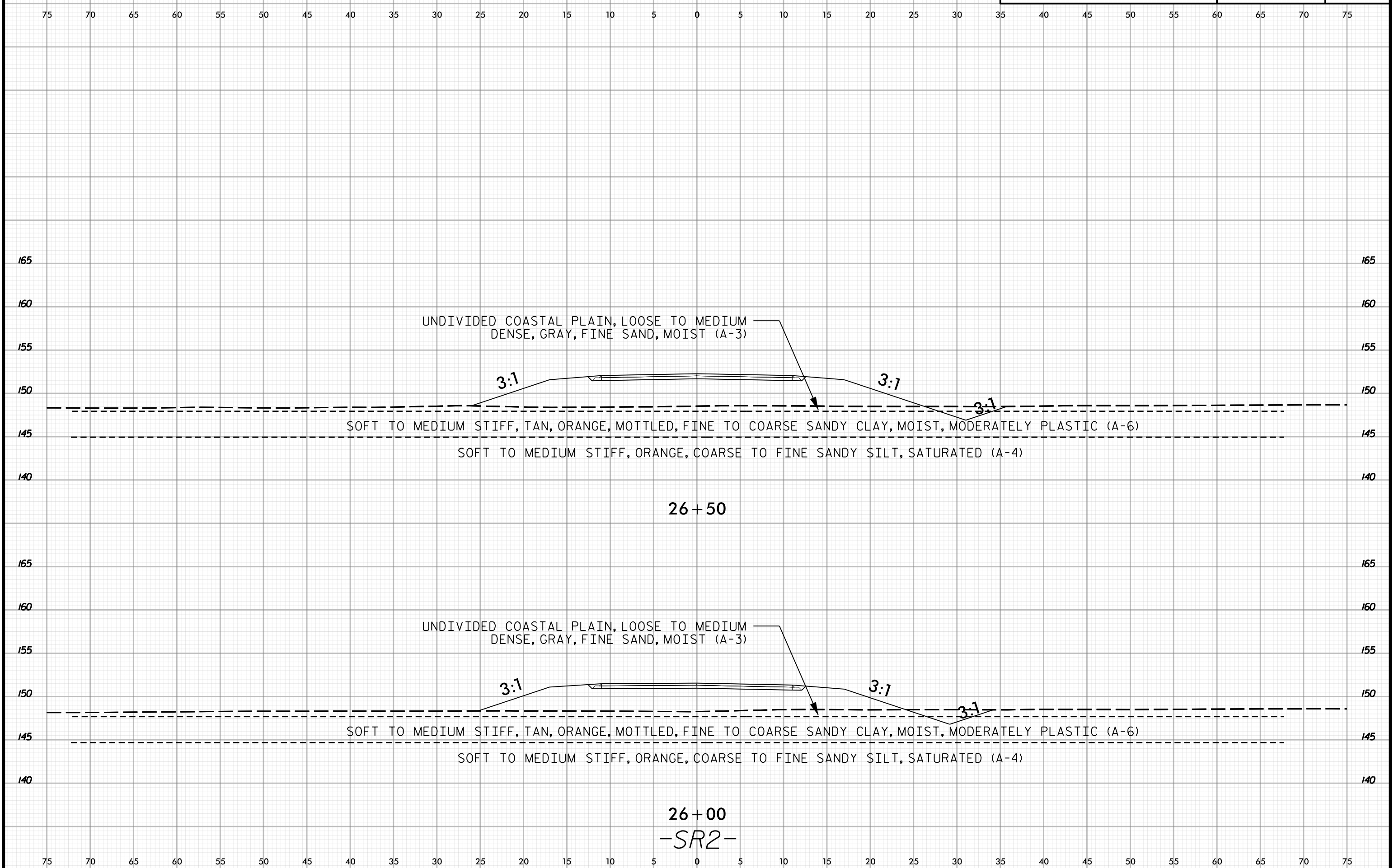

UNDIVIDED COASTAL PLAIN, LOOSE TO MEDIUM DENSE, GRAY, FINE SAND, MOIST (A-3)

3:1

3:1

3:1

SOFT TO MEDIUM STIFF, TAN, ORANGE, MOTTLED, FINE TO COARSE SANDY CLAY, MOIST, MODERATELY PLASTIC (A-6)

SOFT TO MEDIUM STIFF, ORANGE, COARSE TO FINE SANDY SILT, SATURATED (A-4)

26+50

UNDIVIDED COASTAL PLAIN, LOOSE TO MEDIUM DENSE, GRAY, FINE SAND, MOIST (A-3)

3:1

3:1

3:1

SOFT TO MEDIUM STIFF, TAN, ORANGE, MOTTLED, FINE TO COARSE SANDY CLAY, MOIST, MODERATELY PLASTIC (A-6)

SOFT TO MEDIUM STIFF, ORANGE, COARSE TO FINE SANDY SILT, SATURATED (A-4)

26+00

-SR2-



75 70 65 60 55 50 45 40 35 30 25 20 15 10 5 0 5 10 15 20 25 30 35 40 45 50 55 60 65 70 75

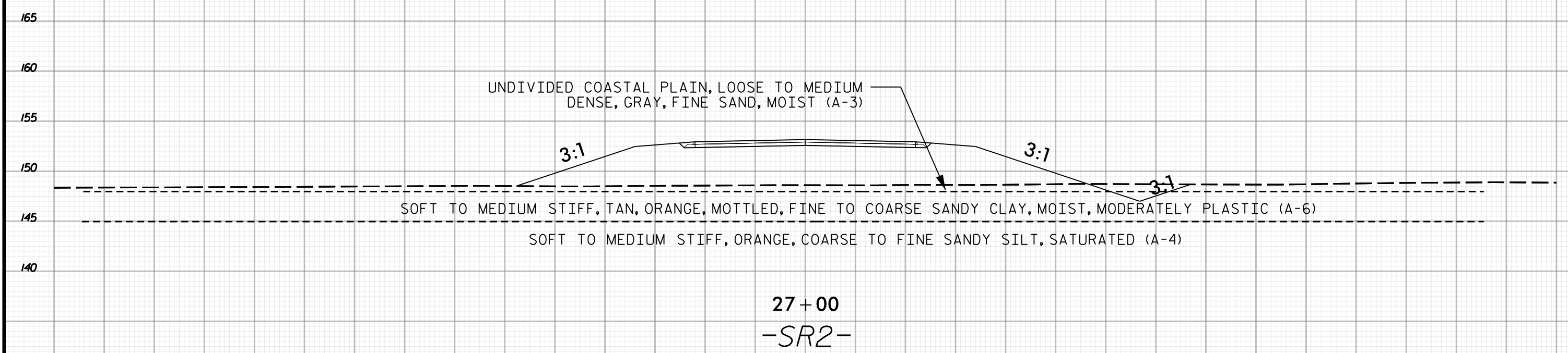
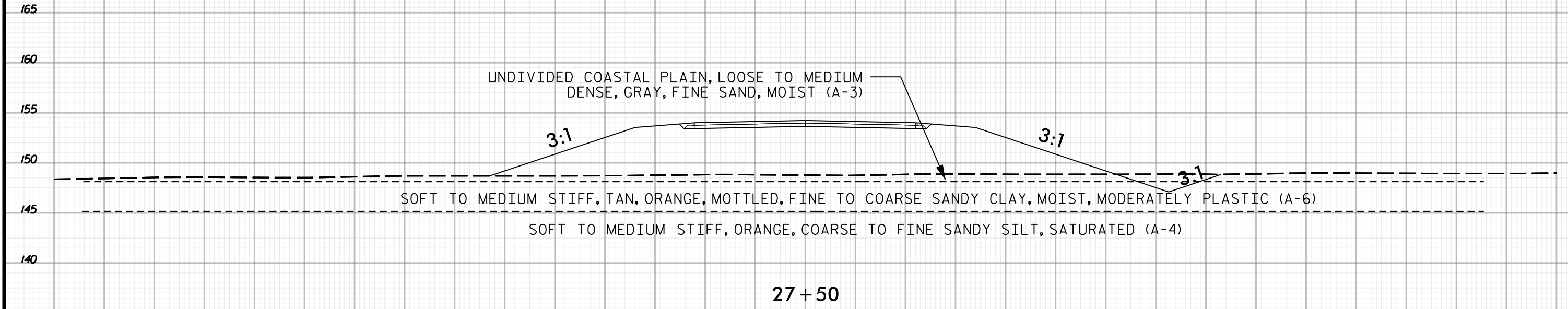

75 70 65 60 55 50 45 40 35 30 25 20 15 10 5 0 5 10 15 20 25 30 35 40 45 50 55 60 65 70 75

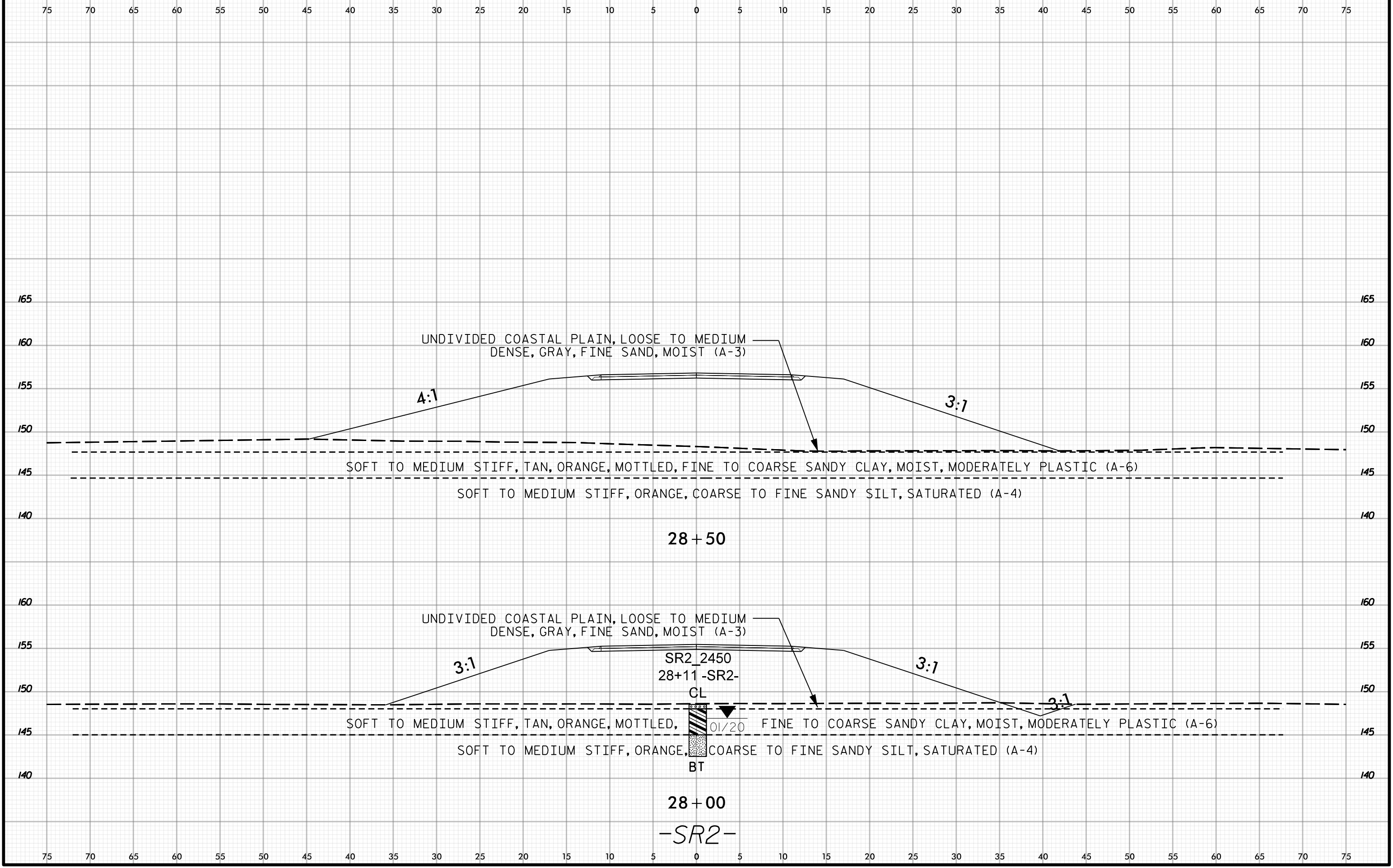

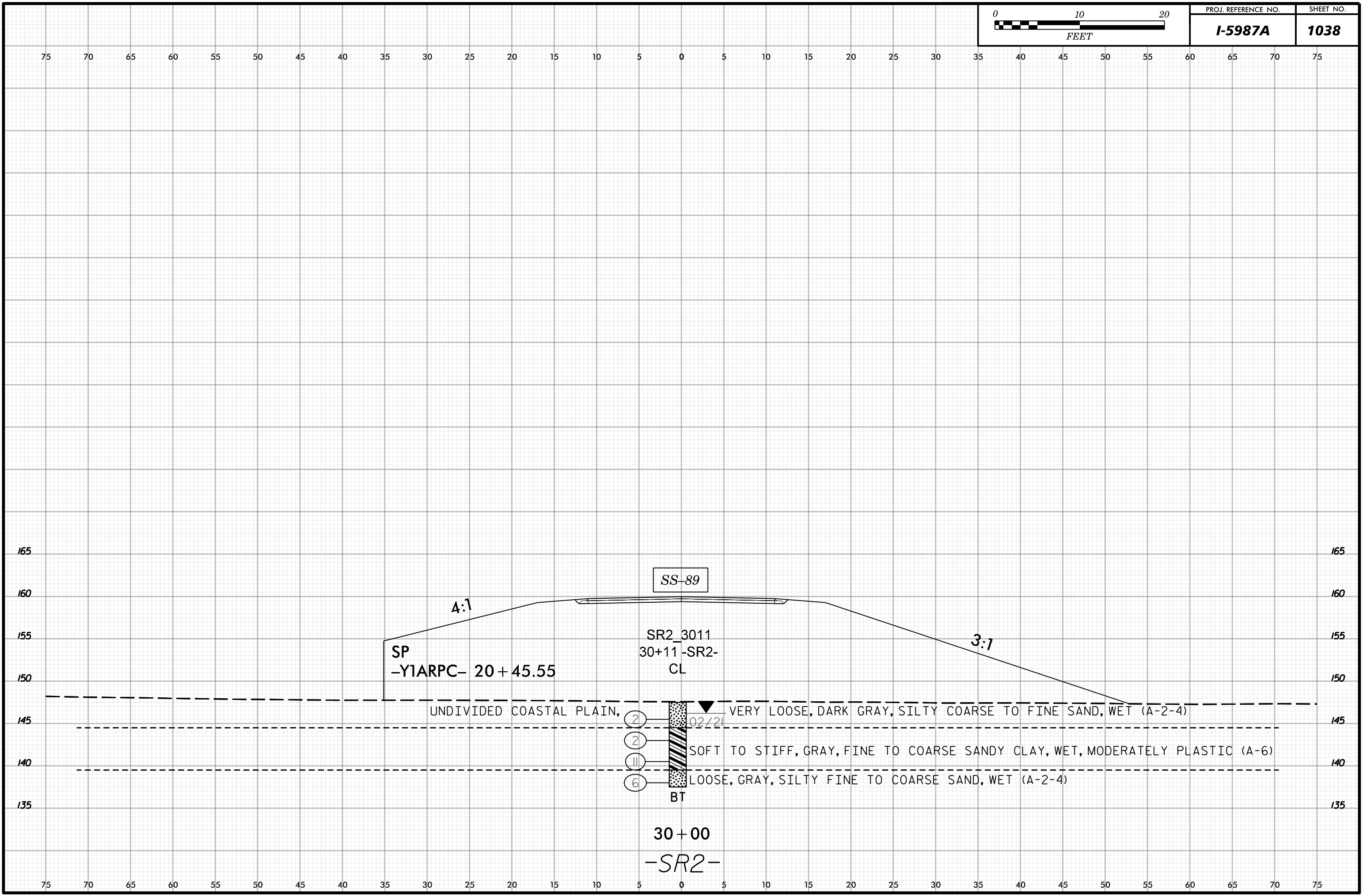
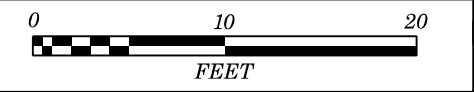



60 55 50 45 40 35 30 25 20 15 10 5 0 5 10 15 20 25 30 35 40 45 50 55 60 65 70 75 80 85 90

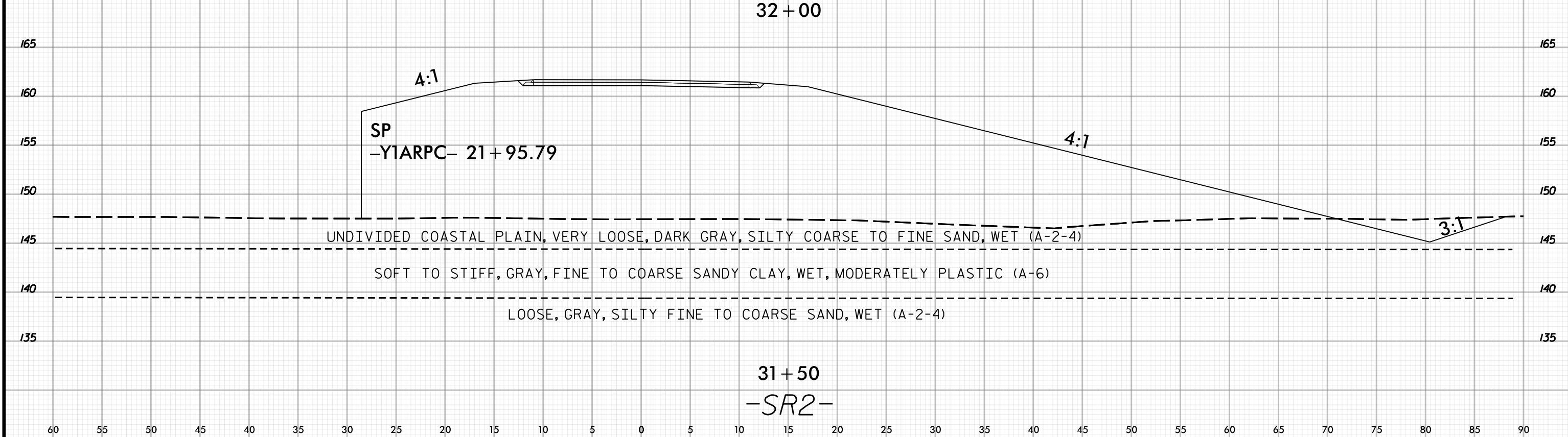
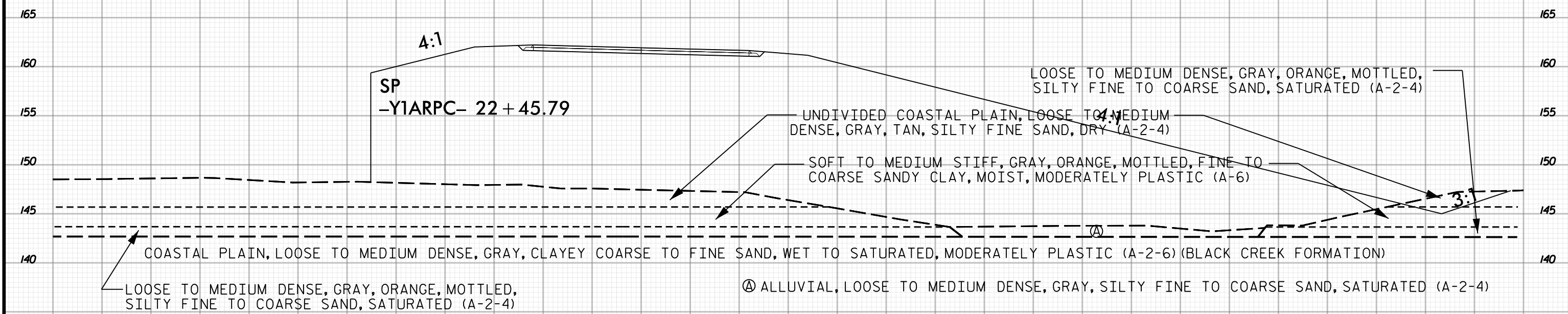

60 55 50 45 40 35 30 25 20 15 10 5 0 5 10 15 20 25 30 35 40 45 50 55 60 65 70 75 80 85 90



65 60 55 50 45 40 35 30 25 20 15 10 5 0 5 10 15 20 25 30 35 40 45 50 55 60 65 70 75 80 85

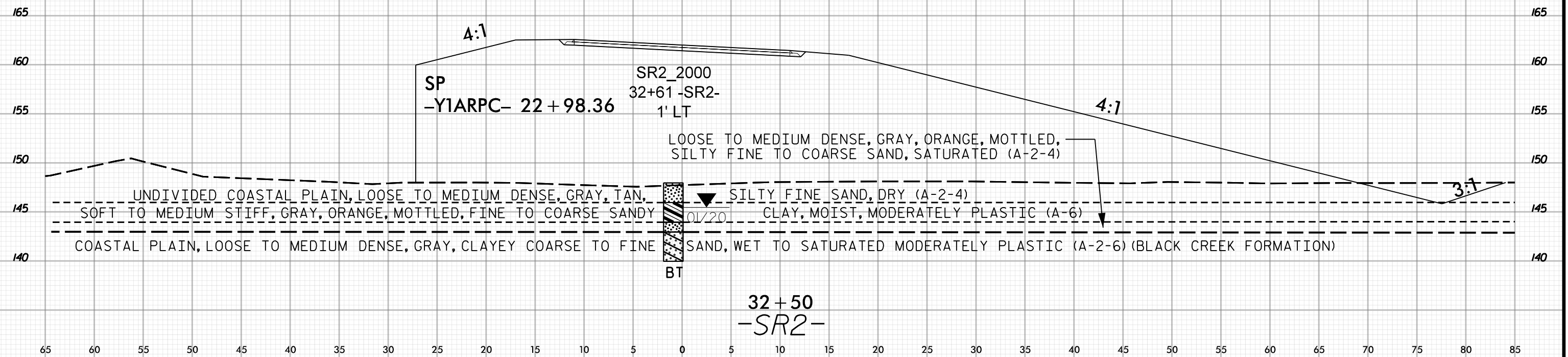

65 60 55 50 45 40 35 30 25 20 15 10 5 0 5 10 15 20 25 30 35 40 45 50 55 60 65 70 75 80 85

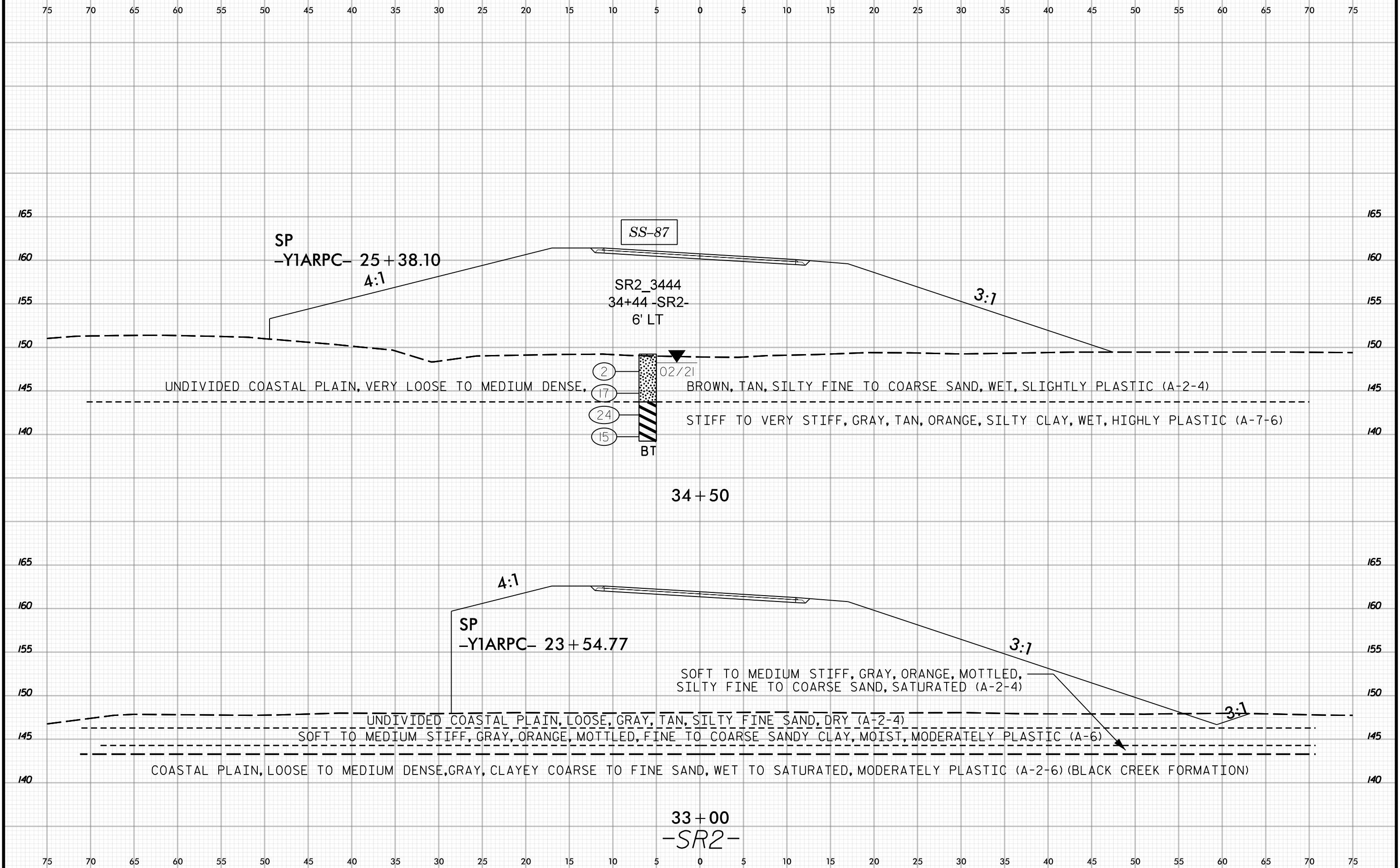

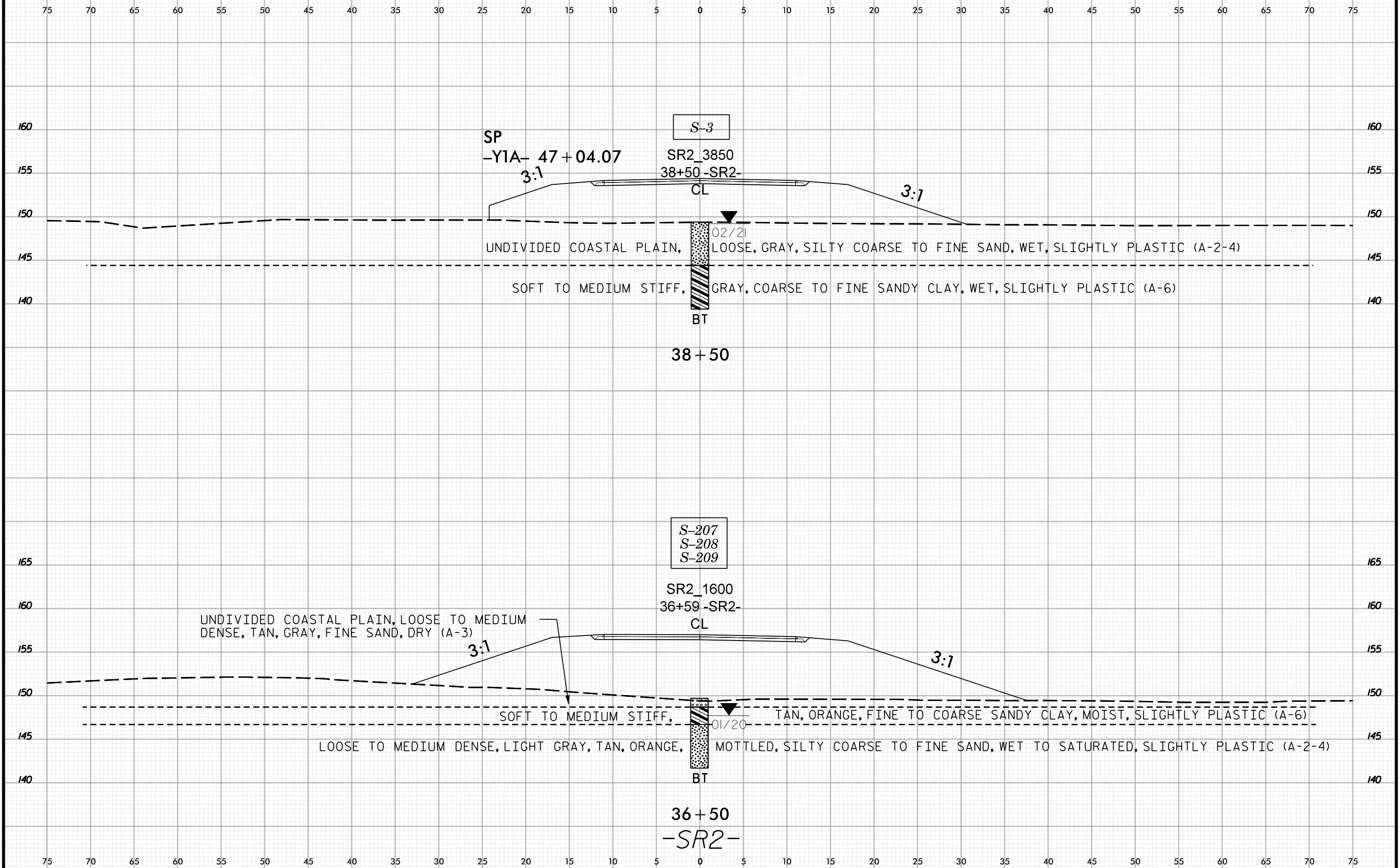

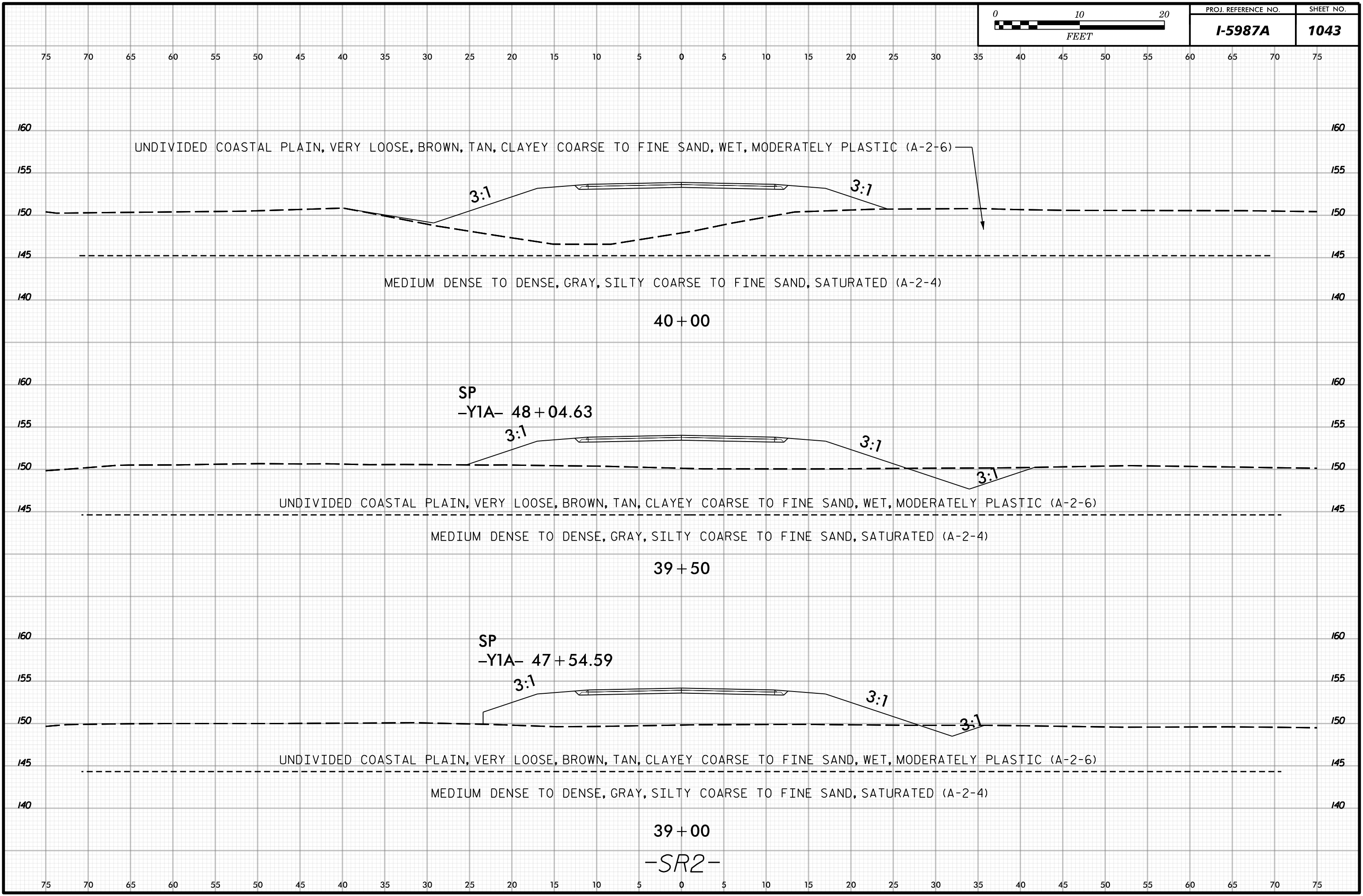

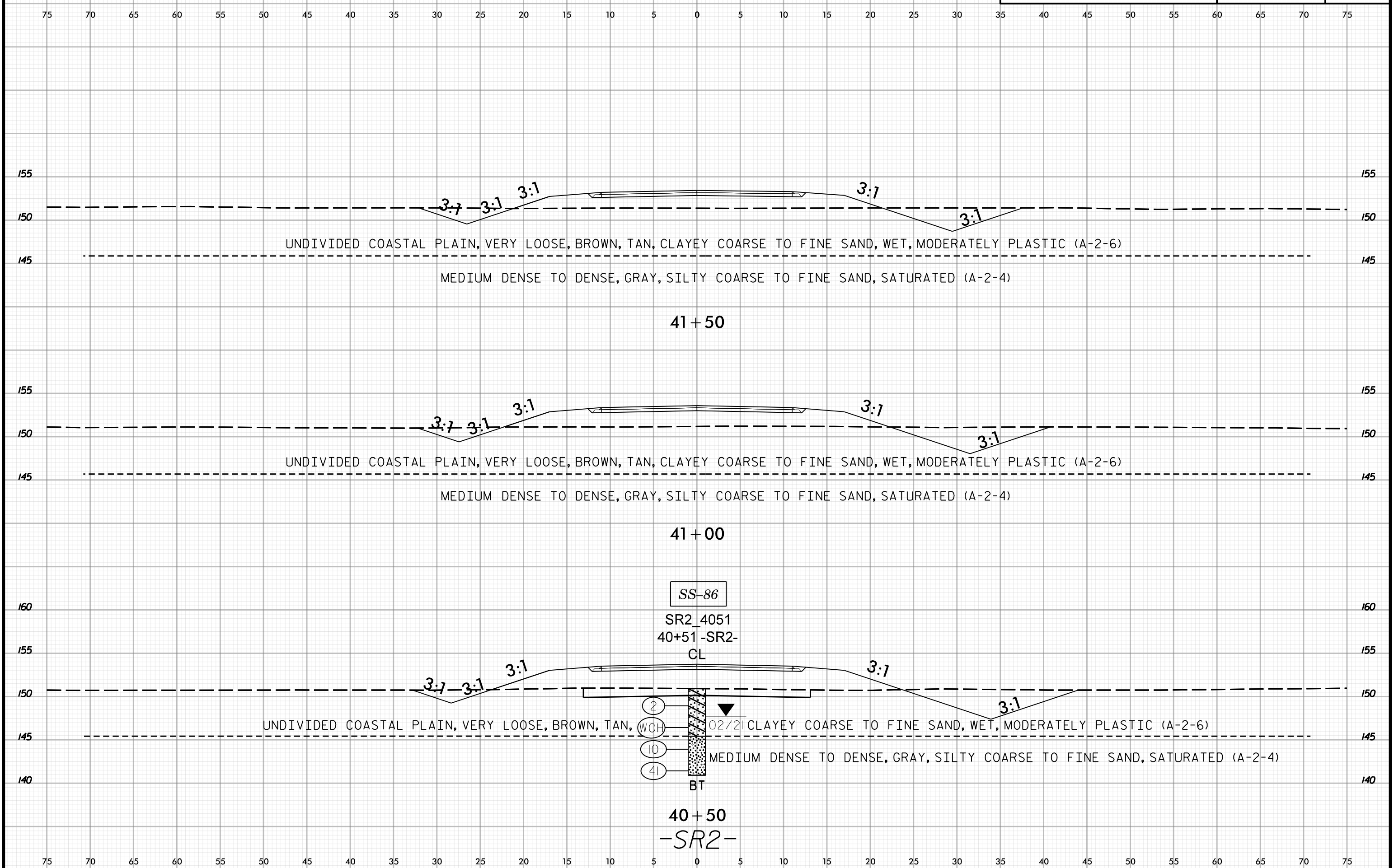
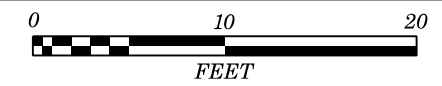

41+50

41+00

SS-86

SR2_4051
40+51-SR2-
CL

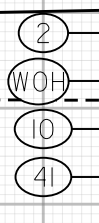

40+50
-SR2-



75 70 65 60 55 50 45 40 35 30 25 20 15 10 5 0 5 10 15 20 25 30 35 40 45 50 55 60 65 70 75

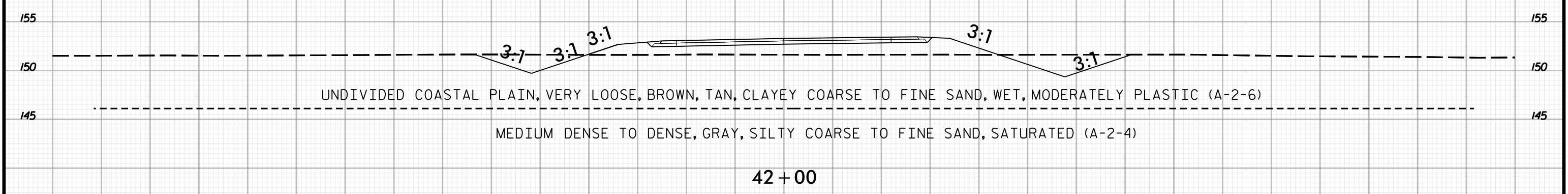
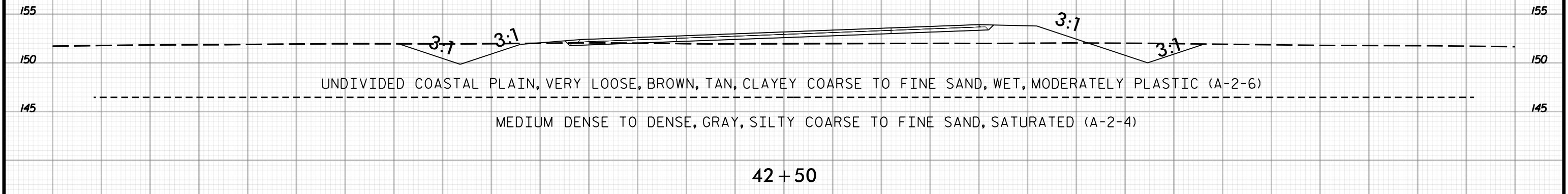
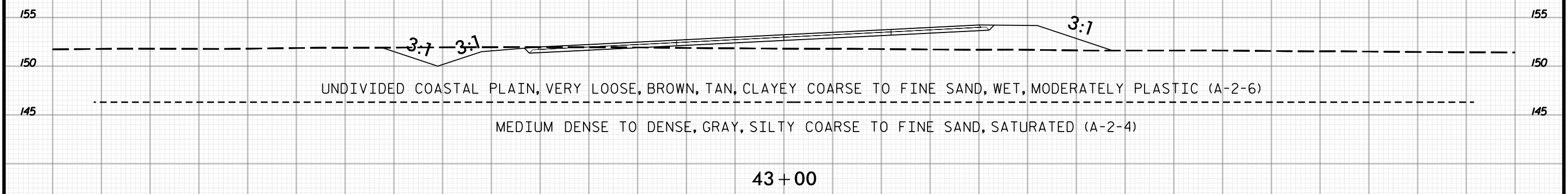

-SR2-

75 70 65 60 55 50 45 40 35 30 25 20 15 10 5 0 5 10 15 20 25 30 35 40 45 50 55 60 65 70 75

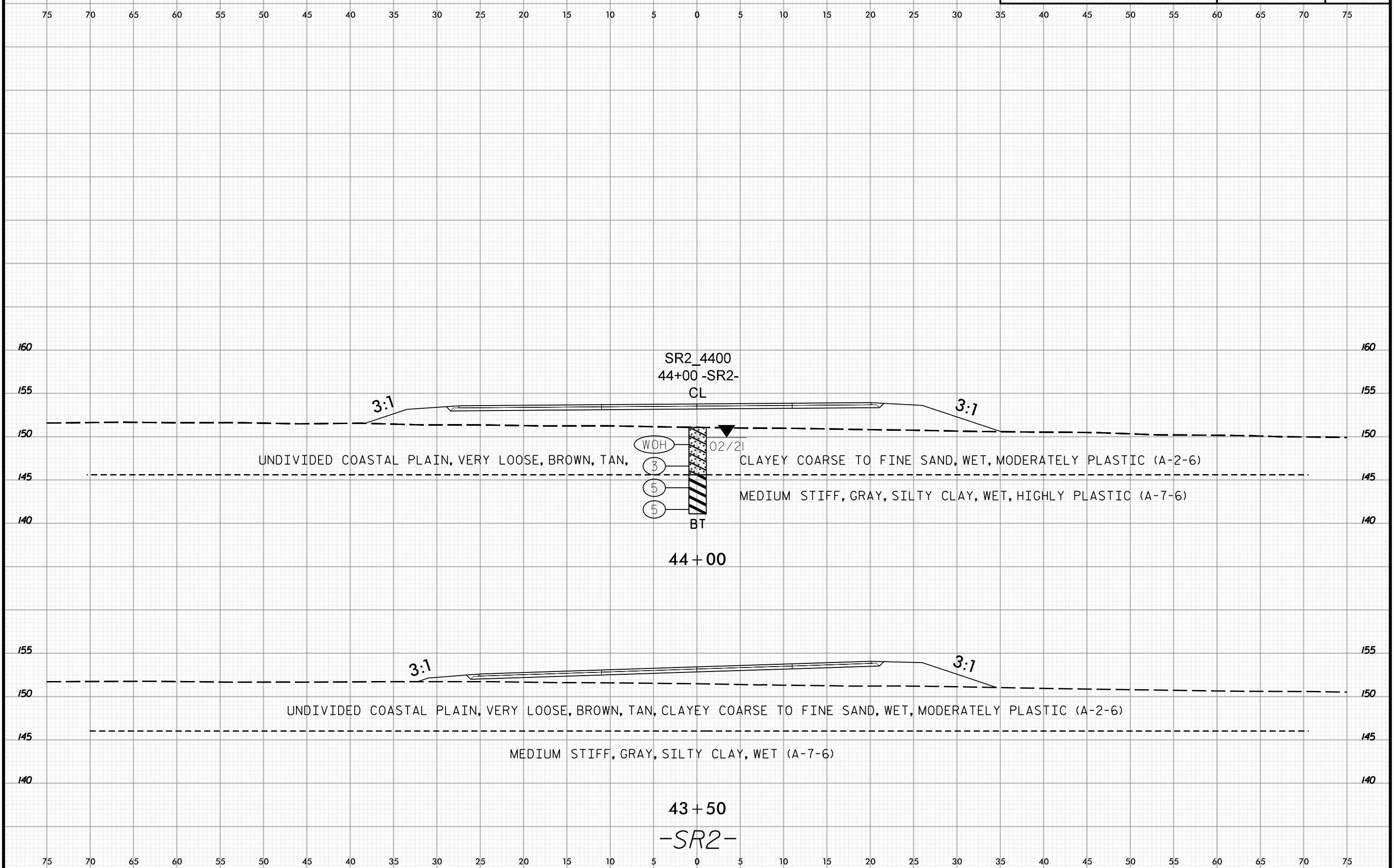

NORTH CAROLINA DEPARTMENT OF TRANSPORTATION
DIVISION OF HIGHWAYS
GEOTECHNICAL ENGINEERING UNIT
SUBSURFACE INVESTIGATION

APPENDIX A

ADDITIONAL BORE LOGS
(DRILLED OFF LIMITS OF CONSTRUCTION)

LABORATORY TESTING SUMMARY

REFERENCE: I-5987A

PROJECT: 47533.1.1

Prepared in the Office of:

Terracon

Consulting Engineers and Scientists
2401 BRENTWOOD ROAD, SUITE 107
RALEIGH, NORTH CAROLINA 27604
NC REGISTERED ENGINEERING FIRM: F-0869
NC REGISTERED GEOLOGIC FIRM: C-367

GEOTECHNICAL BORING REPORT

BORE LOG

WBS 47533.1.1		TIP I-5987		COUNTY ROBESON/CUMBERLAND		GEOLOGIST L. PUGH								
SITE DESCRIPTION I-95 CUMBERLAND/ROBESON COUNTIES FROM US 301 (EXIT 22) TO I-95 BUSINESS/US 301 (EXIT 40)							GROUND WTR (ft)							
BORING NO. Y2_3600		STATION 39+82		OFFSET 25 ft LT		ALIGNMENT -Y2-								
COLLAR ELEV. 143.7 ft		TOTAL DEPTH 10.0 ft		NORTHING 345,799		EASTING 2,001,524								
DRILL RIG/HAMMER EFF./DATE CAT4425 CME-55 87% 01/16/2019			DRILL METHOD MUD ROTARY			HAMMER TYPE AUTOMATIC								
DRILLER J. EDMONDSON		START DATE 01/14/20		COMP. DATE 01/14/20		SURFACE WATER DEPTH N/A								
ELEV (ft)	DRIVE ELEV (ft)	DEPTH (ft)	BLOW COUNT			BLOWS PER FOOT					SAMP. NO.	LOG	SOIL AND ROCK DESCRIPTION	
			0.5ft	0.5ft	0.5ft	0	25	50	75	100				
145	143.7	0.0												143.7 GROUND SURFACE 0.0
			1	2	2									142.4 UNDIVIDED COASTAL PLAIN 1.3
140	139.9	3.8	WOH	2	3									140.7 LOOSE, BROWN, SILTY FINE TO COARSE SAND, MOIST (A-2-4) 3.0
														SOFT TO MEDIUM STIFF, PURPLE GRAY, FINE TO COARSE SANDY CLAY, MOIST, MODERATELY PLASTIC (A-6)
135	135.2	8.5		4	6	7								133.7 MEDIUM STIFF TO STIFF, GRAY, SILTY CLAY, WET (A-7-6) 10.0
														Boring Terminated at Elevation 133.7 ft IN UNDIVIDED COASTAL PLAIN SANDY CLAY

WBS 47533.1.1		TIP I-5987		COUNTY ROBESON/CUMBERLAND		GEOLOGIST C. FUTRAL								
SITE DESCRIPTION I-95 CUMBERLAND/ROBESON COUNTIES FROM US 301 (EXIT 22) TO I-95 BUSINESS/US 301 (EXIT 40)							GROUND WTR (ft)							
BORING NO. Y2_3900		STATION 42+82		OFFSET 24 ft LT		ALIGNMENT -Y2-								
COLLAR ELEV. 146.1 ft		TOTAL DEPTH 6.0 ft		NORTHING 345,613		EASTING 2,001,767								
DRILL RIG/HAMMER EFF./DATE HAND AUGER			DRILL METHOD HAND AUGER			HAMMER TYPE N/A								
DRILLER C. FUTRAL		START DATE 02/05/20		COMP. DATE 02/05/20		SURFACE WATER DEPTH N/A								
ELEV (ft)	DRIVE ELEV (ft)	DEPTH (ft)	BLOW COUNT			BLOWS PER FOOT					SAMP. NO.	LOG	SOIL AND ROCK DESCRIPTION	
			0.5ft	0.5ft	0.5ft	0	25	50	75	100				
150														146.1 GROUND SURFACE 0.0
														144.6 ROADWAY EMBANKMENT 1.5
145														142.1 MEDIUM DENSE, TAN, SILTY FINE SAND, MOIST, FEW CLAY NODULES (A-2-4) 4.0
														UNDIVIDED COASTAL PLAIN
														LOOSE TO MEDIUM DENSE, TAN, RED, ORANGE, MOTTLED, CLAYEY FINE SAND, MOIST (A-2-6)
														SOFT TO MEDIUM STIFF, GRAY, TAN, ORANGE, MOTTLED, SANDY FINE TO COARSE CLAY, MOIST TO WET (A-6)
														Boring Terminated at Elevation 140.1 ft IN UNDIVIDED COASTAL PLAIN SANDY CLAY

LABORATORY TESTING SUMMARY

PROJECT NUMBER: 47533.1.2

TIP: I-5987A

COUNTY: ROBESON

DESCRIPTION: I-95 IMPROVEMENTS FROM SOUTH OF US 301 (EXIT 22) TO NORTH OF SR 1758 (McDUFFIE CROSSING RD.)

Sample No.	Station	Alignment	Offset (feet)	Depth Interval (feet)	AASHTO Class.	L.L.	P.I.	% by Weight				% Retained #4 Sieve	% Passing (sieves)			% Moisture	% Organic
								Coarse Sand	Fine Sand	Silt	Clay		#10	#40	#200		
SS-1	89+49	-L-	61 RT	1.0 - 2.5	A-7-6 (7)	48	34	26.8	37.7	4.4	31.1	0	100	90	39	16.2	--
SS-2	94+85	-L-	65 RT	1.0 - 2.5	A-6 (9)	39	25	17.4	35.2	23.6	23.8	0	100	94	51	23.6	--
SS-3	99+00	-L-	65 RT	1.0 - 2.5	A-2-6 (2)	39	27	34.6	34.8	6.2	24.4	0	100	88	32	--	--
SS-4	99+00	-L-	65 RT	6.0 - 7.5	A-3 (0)	NP	NP	35.4	55.6	0.2	8.8	0	100	88	9	--	--
SS-5	17+23	-Y1RPD-	23 LT	1.0 - 2.5	A-2-4 (0)	22	10	38.5	33.7	10.8	17.0	1	99	79	30	--	--
SS-6	150+00	-L-	85 RT	8.5 - 10.0	A-6 (5)	40	27	29.5	33.1	7.7	29.7	0	100	86	40	16.3	--
SS-7	154+50	-L-	90 RT	1.0 - 2.5	A-2-6 (0)	26	11	35.1	41.8	3.7	19.4	0	100	84	25	--	--
SS-8	197+00	-L-	63 RT	1.0 - 2.5	A-2-4 (0)	23	10	22.1	51.2	9.9	16.8	0	100	89	28	--	--
SS-9	232+00	-L-	105 RT	3.5 - 5.0	A-2-4 (0)	18	2	54.3	29.2	5.4	11.1	0	99	67	19	--	--
SS-10	232+00	-L-	105 RT	8.5 - 10.0	A-2-6 (0)	27	15	27.6	43.5	4.9	24.0	0	100	86	31	--	--
SS-11	260+00	-L-	90 RT	3.5 - 5.0	A-2-4 (0)	24	3	25.5	51.9	12.4	10.2	1	97	85	24	--	--
SS-12	266+99	-L-	66 RT	1.0 - 2.5	A-2-6 (1)	33	20	23.6	45.8	4.7	25.9	0	100	89	32	--	--
SS-13	272+00	-L-	75 RT	6.0 - 7.5	A-2-4 (0)	26	9	49.1	34.0	6.0	10.9	0	99	72	17	--	--
SS-14	330+00	-L-	81 RT	1.0 - 2.5	A-2-4 (0)	NP	NP	25.8	58.6	6.3	9.3	0	100	88	17	--	--
SS-15	330+00	-L-	81 RT	3.5 - 5.0	A-3 (0)	NP	NP	29.0	66.2	4.7	0.1	0	100	85	6	--	--
SS-16	335+00	-L-	82 RT	1.0 - 2.5	A-2-4 (0)	20	1	31.6	51.6	6.0	10.8	0	100	84	18	--	--
SS-17	339+25	-L-	81 RT	1.0 - 2.5	A-7-6 (12)	41	25	14.3	28.2	17.5	40.0	0	100	93	60	19.2	--
SS-18	367+50	-L-	82 RT	1.0 - 2.5	A-2-4 (0)	NP	NP	27.5	62.1	7.7	2.7	0	100	87	12	--	--
SS-19	367+50	-L-	82 RT	6.0 - 7.5	A-6 (4)	29	16	23.7	33.5	14.9	27.9	0	100	90	46	18.5	--
SS-20	390+00	-L-	75 RT	1.0 - 2.5	A-6 (6)	37	22	35.2	20.9	14.9	29.0	0	100	78	47	17.8	--
SS-21	445+00	-L-	80 RT	3.5 - 5.0	A-2-6 (0)	33	15	46.4	24.6	10.8	18.2	0	100	71	32	--	--
SS-22	459+00	-L-	81 RT	3.5 - 5.0	A-7-6 (9)	53	32	39.8	18.5	11.3	30.4	0	100	74	44	22.3	--
SS-23	459+00	-L-	78 LT	1.0 - 2.5	A-7-6 (18)	49	31	21.7	16.0	19.5	42.8	0	100	87	65	21.2	--
SS-24	459+00	-L-	78 LT	6.0 - 7.5	A-2-6 (0)	32	17	53.7	25.3	5.2	15.8	0	100	68	23	--	--
SS-25	435+00	-L-	70 LT	6.0 - 7.5	A-6 (5)	32	19	37.5	17.8	22.8	21.9	0	100	76	47	16.6	--
SS-26	420+00	-L-	70 LT	1.0 - 2.5	A-7-6 (4)	41	20	38.8	20.5	10.7	30.0	0	100	76	43	18.3	--
SS-27	370+50	-L-	79 LT	3.5 - 5.0	A-2-6 (0)	36	22	57.9	20.1	1.4	20.6	0	100	64	23	--	--
SS-28	350+00	-L-	78 LT	1.0 - 2.5	A-6 (5)	31	13	13.9	30.0	22.3	33.8	0	100	94	59	22.5	--
SS-29	345+00	-L-	79 LT	1.0 - 2.5	A-4 (0)	23	8	21.8	41.2	19.2	17.8	0	100	90	40	21.1	--
SS-30	335+00	-L-	78 LT	1.0 - 2.5	A-2-6 (0)	26	14	28.1	43.4	10.5	18.0	0	100	86	30	--	--
SS-31	330+00	-L-	79 LT	6.0 - 7.5	A-7-6 (47)	69	47	5.0	8.2	21.2	65.6	0	100	96	90	60.8	--
SS-32	330+00	-L-	79 LT	12.6 - 14.1	A-2-6 (1)	36	23	51.0	18.6	8.5	21.9	4	91	64	29	--	--
SS-33	319+00	-L-	78 LT	1.0 - 2.5	A-2-4 (0)	18	2	29.1	50.6	2.7	17.6	0	97	83	21	--	--
SS-34	10+87	-Y1ARPA-	25 RT	1.0 - 2.5	A-2-4 (0)	19	4	43.3	33.6	12.3	10.8	0	100	74	25	--	--
SS-35	10+87	-Y1ARPA-	25 RT	6.0 - 7.5	A-6 (4)	31	19	12.0	47.2	10.5	30.3	0	100	96	43	15.0	--
SS-36	14+88	-Y1ARPA-	7 RT	1.0 - 2.5	A-6 (4)	36	23	44.1	16.6	7.2	32.1	0	100	68	40	14.3	--
SS-37	17+87	-Y1ARPA-	21 LT	6.0 - 7.5	A-2-6 (1)	30	18	30.8	40.9	5.8	22.5	0	100	84	30	--	--
SS-38	294+00	-L-	70 LT	1.0 - 2.5	A-2-6 (1)	25	13	31.3	35.2	7.0	26.5	0	100	84	35	--	--
SS-39	294+00	-L-	70 LT	6.0 - 7.5	A-2-4 (0)	20	3	57.8	29.7	1.6	10.9	0	99	59	13	--	--
SS-40	19+00	-Y1ARPB-	CL	13.5 - 15.0	A-7-6 (17)	49	35	15.5	29.5	12.9	42.1	0	100	93	59	42.4	--

NP - NON-PLASTIC

Stephanie H. Huffman

Certified Lab Technician Signature

114-01-1203

Certification Number

LABORATORY TESTING SUMMARY

PROJECT NUMBER: 47533.1.2

TIP: I-5987A

COUNTY: ROBESON

DESCRIPTION: I-95 IMPROVEMENTS FROM SOUTH OF US 301 (EXIT 22) TO NORTH OF SR 1758 (McDUFFIE CROSSING RD.)

Sample No.	Station	Alignment	Offset (feet)	Depth Interval (feet)	AASHTO Class.	L.L.	P.I.	% by Weight				% Retained #4 Sieve	% Passing (sieves)			% Moisture	% Organic
								Coarse Sand	Fine Sand	Silt	Clay		#10	#40	#200		
SS-41	260+00	-L-	85 LT	1.0 - 2.5	A-6 (1)	25	13	14.9	51.0	7.3	26.8	0	100	94	36	12.7	--
SS-42	250+00	-L-	109 LT	1.0 - 2.5	A-4 (0)	21	7	31.6	26.8	20.0	21.6	0	100	81	45	15.3	--
SS-43	232+00	-L-	110 LT	1.0 - 2.5	A-2-4 (0)	26	10	23.2	51.1	5.9	19.8	0	100	89	27	--	--
SS-44	232+00	-L-	110 LT	8.5 - 10.0	A-6 (3)	31	20	19.6	43.0	7.2	30.2	0	100	91	40	14.9	--
SS-45	225+00	-L-	112 LT	6.0 - 7.5	A-6 (4)	29	16	23.0	30.8	12.4	33.8	0	100	88	49	16.5	--
SS-46	214+50	-L-	90 LT	6.0 - 7.5	A-6 (6)	32	19	20.3	33.1	16.6	30.0	0	100	90	52	17.3	--
SS-47	177+00	-L-	95 LT	1.0 - 2.5	A-6 (4)	34	20	23.1	38.5	11.4	27.0	0	100	90	41	13.9	--
SS-48	177+00	-L-	95 LT	6.0 - 7.5	A-7-6 (21)	62	43	16.0	27.3	6.6	50.1	0	100	95	58	22.2	--
SS-49	172+00	-L-	94 LT	1.0 - 2.5	A-6 (3)	30	17	26.4	35.6	11.1	26.9	0	100	88	41	15.3	--
SS-50	172+00	-L-	94 LT	13.5 - 15.0	A-2-4 (0)	24	3	34.2	51.0	0.6	14.2	0	100	83	15	--	--
SS-51	161+50	-L-	94 LT	13.5 - 15.0	A-2-4 (0)	NP	NP	62.1	27.8	0.8	9.3	0	100	75	11	--	--
SS-52	111+18	-L-	78 LT	6.0 - 7.5	A-6 (6)	33	23	21.0	36.2	11.0	31.8	0	100	93	45	16.8	--
SS-53	95+30	-L-	64 LT	3.5 - 5.0	A-7-6 (12)	56	42	21.8	35.9	6.4	35.9	0	100	93	45	17.6	--
SS-54	200+00	-L-	3 RT	6.0 - 7.5	A-6 (10)	39	25	21.7	25.5	15.2	37.6	0	100	88	55	18.4	--
SS-55	32+43	-Y3-	97 LT	3.5 - 5.0	A-7-6 (7)	48	30	34.8	25.9	5.5	33.8	0	100	81	42	24.0	--
SS-56	242+65	-L-	12 RT	1.0 - 2.5	A-6 (7)	35	21	32.5	19.3	13.9	34.3	0	100	80	51	17.3	--
SS-57	255+00	-L-	9 RT	1.0 - 2.5	A-6 (3)	30	18	21.5	39.0	8.1	31.4	0	100	90	42	20.4	--
SS-58	24+96	-Y1ARPD-	6 LT	3.5 - 5.0	A-2-6 (0)	25	11	37.6	40.4	4.7	17.3	0	100	83	24	--	--
SS-59	24+96	-Y1ARPD-	6 LT	17.3 - 18.8	A-7-6 (15)	45	28	1.9	39.0	12.6	46.5	0	100	100	64	58.0	--
SS-60	21+96	-Y1ARPD-	29 RT	17.9 - 19.4	A-2-6 (0)	25	11	50.5	28.5	5.4	15.6	0	99	75	21	--	--
SS-61	41+61	-Y1A-	191 RT	3.5 - 5.0	A-6 (3)	36	22	27.5	36.4	7.1	29.0	0	100	86	38	21.7	--
SS-62	41+61	-Y1A-	191 RT	8.5 - 10.0	A-2-4 (0)	23	5	41.7	40.9	0.4	17.0	0	100	80	18	--	--
SS-63	42+29	-Y1A-	197 LT	12.0 - 13.5	A-2-4 (0)	27	7	7.9	72.1	0.5	19.5	0	100	97	21	--	--
SS-64	26+10	-Y3-	1 RT	1.0 - 2.5	A-2-6 (0)	26	12	21.3	53.9	2.7	22.1	0	100	93	26	--	--
SS-65	30+36	-Y3-	95 RT	1.0 - 2.5	A-6 (7)	38	25	34.6	19.5	11.7	34.2	0	100	78	48	20.3	--
SS-66	30+36	-Y3-	95 RT	6.0 - 7.5	A-2-6 (0)	28	13	54.3	26.7	2.0	17.0	0	99	68	21	--	--
SS-67	461+50	-L-	82 RT	1.0 - 2.5	A-7-6 (6)	41	26	40.6	19.4	7.5	32.5	0	99	73	42	19.5	--
SS-68	29+76	-Y3-	85 LT	1.0 - 2.5	A-7-6 (8)	43	26	34.0	22.1	8.7	35.2	0	99	78	47	17.3	--
SS-69	29+76	-Y3-	85 LT	8.5 - 10.0	A-2-6 (0)	40	25	53.2	23.5	1.5	21.8	0	99	69	25	--	--
SS-70	461+50	-L-	65 LT	1.0 - 2.5	A-7-6 (6)	43	28	40.4	20.2	6.8	32.6	0	99	72	42	17.5	--
SS-71	314+00	-L-	75 LT	1.0 - 2.5	A-2-6 (0)	26	11	28.9	49.5	1.4	20.2	0	99	87	22	--	--
SS-72	314+00	-L-	75 LT	6.0 - 7.5	A-7-6 (17)	45	26	9.0	23.5	16.0	51.5	0	100	97	70	35.5	--
SS-73	367+50	-L-	59 LT	8.5 - 10.0	A-2-4 (0)	NP	NP	37.1	45.5	6.9	10.5	0	100	84	21	--	--
SS-74	311+15	-L-	46 RT	3.5 - 5.0	A-2-4 (0)	18	2	25.0	52.4	5.3	17.3	0	100	89	25	--	--
SS-75	405+00	-L-	6 RT	3.5 - 5.0	A-2-6 (2)	37	21	41.8	25.7	7.0	25.5	0	100	74	35	--	--
SS-76	310+94	-L-	13 LT	8.5 - 10.0	A-2-6 (1)	35	18	31.7	38.7	4.8	24.8	0	100	82	31	--	--
SS-77	424+50	-L-	7 LT	1.0 - 2.5	A-2-6 (2)	38	22	46.1	23.9	4.3	25.7	0	100	73	32	--	--
SS-78	350+00	-L-	6 LT	3.5 - 5.0	A-2-4 (0)	23	4	24.7	55.2	1.6	18.5	0	100	92	21	--	--
SS-79	314+01	-L-	9 LT	1.0 - 2.5	A-2-6 (0)	27	11	33.8	44.8	2.6	18.8	0	99	84	22	--	--
SS-80	264+99	-L-	2 LT	1.0 - 2.5	A-2-6 (0)	25	12	23.6	47.9	6.1	22.4	0	100	90	30	--	--

NP - NON-PLASTIC

Stephanie H. Huffman

Certified Lab Technician Signature

114-01-1203

Certification Number

LABORATORY TESTING SUMMARY

PROJECT NUMBER: 47533.1.2

TIP: I-5987A

COUNTY: ROBESON

DESCRIPTION: I-95 IMPROVEMENTS FROM SOUTH OF US 301 (EXIT 22) TO NORTH OF SR 1758 (McDUFFIE CROSSING RD.)

Sample No.	Station	Alignment	Offset (feet)	Depth Interval (feet)	AASHTO Class.	L.L.	P.I.	% by Weight				% Retained #4 Sieve	% Passing (sieves)			% Moisture	% Organic
								Coarse Sand	Fine Sand	Silt	Clay		#10	#40	#200		
SS-284	67+00	-L-	62 RT	0.2 - 1.0	A-2-4 (0)	23	8	33.0	36.4	8.3	22.3	0	100	83	34	14.2	1.7
SS-285	67+00	-L-	62 RT	1.0 - 1.5	A-6 (4)	31	14	12.3	41.8	14.0	31.9	0	100	97	50	17.4	--
SS-286	67+00	-L-	62 RT	3.5 - 5.0	A-7-6 (11)	44	30	11.4	40.3	14.5	33.8	0	100	98	52	19.5	--
SS-296	68+00	-L-	61 RT	3.5 - 5.0	A-7-6 (16)	52	36	12.2	36.5	16.6	34.7	0	100	97	56	20.3	--
SS-303	70+00	-L-	62 RT	3.5 - 5.0	A-7-6 (12)	42	30	17.5	33.2	11.1	38.2	0	100	95	54	17.4	--
SS-306	72+00	-L-	62 RT	3.5 - 5.0	A-6 (2)	26	12	19.5	42.2	13.0	25.3	1	99	92	42	14.1	--
SS-2245	72+50	-L-	62 LT	3.5 - 5.0	A-6 (5)	31	13	9.7	32.8	21.7	35.8	0	100	97	62	27.2	--
SS-2246	72+50	-L-	62 LT	8.5 - 10.0	A-6 (9)	37	26	20.1	31.2	12.6	36.1	0	100	86	52	14.1	--
SS-307	73+00	-L-	55 RT	4.0 - 5.0	A-4 (0)	18	4	9.4	34.7	25.5	30.4	0	100	98	60	18.3	--
SS-2237	74+49	-L-	64 LT	8.5 - 10.0	A-2-6 (3)	40	26	36.5	31.3	1.0	31.2	0	100	96	33	18.1	--
SS-315	75+00	-L-	62 RT	8.5 - 10.0	A-7-6 (56)	87	69	4.9	22.0	16.2	59.9	0	100	99	78	47.0	--
SS-316	75+00	-L-	62 RT	18.5 - 20.0	A-7-5 (40)	80	38	7.5	9.2	49.0	34.3	0	100	96	85	121.7	--
SS-2231	75+48	-L-	63 LT	3.5 - 5.0	A-7-6 (11)	44	31	19.8	35.0	9.3	35.9	0	100	94	50	20.9	--
SS-2223	77+49	-L-	64 LT	4.5 - 5.0	A-7-6 (28)	64	49	9.7	32.3	17.1	40.9	0	100	98	64	30.9	--
SS-2219	78+46	-L-	67 LT	3.5 - 5.0	A-7-6 (13)	45	31	19.3	29.9	16.4	34.4	0	100	91	55	22.4	2.7
SS-2135	79+00	-L-	70 RT	3.5 - 5.0	A-7-6 (7)	42	26	10.2	48.8	10.4	30.6	0	100	97	46	20.3	--
SS-2215	79+50	-L-	64 LT	3.5 - 5.0	A-6 (11)	34	23	12.4	27.8	24.8	35.0	0	100	95	65	14.9	--
SS-2137	80+00	-L-	74 RT	3.5 - 5.0	A-2-4 (0)	30	5	6.9	68.2	1.7	23.2	0	100	98	32	21.7	--
SS-2140	81+00	-L-	74 RT	0.0 - 1.5	A-7-6 (6)	43	17	9.8	44.4	8.4	37.4	0	100	97	51	24.2	--
SS-2208	81+51	-L-	63 LT	0.2 - 1.5	A-7-6 (17)	58	37	5.8	44.6	8.8	40.8	0	100	99	55	24.2	3.5
SS-2143	82+04	-L-	82 RT	8.5 - 10.0	A-7-6 (19)	53	35	1.7	43.6	7.1	47.6	0	100	100	61	54.2	--
SS-2206	82+48	-L-	73 LT	3.5 - 5.0	A-7-6 (15)	52	33	0.9	49.7	4.9	44.5	0	100	100	56	25.5	--
SS-2203	83+41	-L-	74 LT	8.5 - 10.0	A-7-6 (6)	42	21	0.9	59.3	9.1	30.7	0	100	100	48	41.3	--
SS-2146	84+03	-L-	80 RT	0.0 - 1.5	A-7-6 (11)	43	26	18.3	31.1	18.5	32.1	0	100	91	55	19.7	3.0
SS-2147	84+03	-L-	80 RT	8.5 - 10.0	A-7-5 (42)	70	38	1.5	7.8	16.9	73.8	0	100	99	92	92.4	--
SS-2199	84+43	-L-	74 LT	8.5 - 10.0	A-7-6 (29)	61	33	3.3	21.6	21.1	54.0	0	100	98	80	81.0	--
SS-2194	85+41	-L-	75' LT	0.3 - 1.5	ND	ND	ND	ND	ND	ND	ND	ND	ND	ND	ND	11.1	4.2
SS-329	85+98	-L-	79' RT	0.1 - 1.5	ND	ND	ND	ND	ND	ND	ND	ND	ND	ND	ND	12	3.7
SS-2192	86+41	-L-	76 LT	3.5 - 5.0	A-2-7 (3)	55	39	47.7	22.8	1.0	28.5	0	100	78	31	16.7	--
SS-331	86+97	-L-	88 RT	3.5 - 5.0	A-7-6 (7)	43	26	19.4	39.9	9.9	30.8	0	100	93	46	28.2	--
SS-1050	285+70	-L-	74 LT	3.5 - 5.0	A-6 (2)	30	16	26.1	33.6	7.7	32.6	0	100	88	40	19.6	--
SS-1015	285+90	-L-	76 RT	3.5 - 5.0	A-2-6 (1)	30	15	33.4	33.5	7.9	25.2	0	100	96	80	21.5	--
SS-1016	285+90	-L-	76 RT	13.5 - 15.0	A-7-6 (32)	55	40	6.6	17.6	27.3	48.5	0	100	96	80	88.2	--
SS-65 FR	286+81	-L-	84 LT	8.5 - 10.0	A-7-5 (53)	81	49	2.6	8.6	17.4	71.4	0	100	99	92	75.8	--
SS-66 FR	286+81	-L-	84 LT	13.5 - 15.0	A-2-4 (0)	NP	NP	59.2	24.3	7.5	9.0	0	98	69	17	36.0	--
SS-1518	287+11	-L-	86 RT	3.5 - 5.0	A-6 (6)	40	23	24.0	29.9	8.1	38.0	0	100	87	48	21.0	--
SS-1520	287+11	-L-	86 RT	13.5 - 15.0	A-7-6 (20)	54	30	11.6	22.2	14.6	51.6	0	100	95	69	19.8	--
ST-1502	288+02	-L-	75 LT	10.0 - 14.0	A-7-6 (73)	91	67	0.8	9.0	22.2	68.0	0	100	100	95	61.1	--
ST-1503	288+02	-L-	75 LT	12.0 - 14.0	A-7-6 (73)	91	67	0.8	9.0	22.2	68.0	0	100	100	95	61.1	--
SS-1811	288+05	-L-	74 LT	9.5 - 10.0	A-7-6 (53)	74	53	2.2	10.6	19.0	68.2	0	100	99	92	58.7	--

NP - NON-PLASTIC

D. COUNCIL - F&R
 Certified Lab Technician Signature

101-02-0603
 Certification Number

LABORATORY TESTING SUMMARY

PROJECT NUMBER: 47533.1.2

TIP: I-5987A

COUNTY: ROBESON

DESCRIPTION: I-95 IMPROVEMENTS FROM SOUTH OF US 301 (EXIT 22) TO NORTH OF SR 1758 (McDUFFIE CROSSING RD.)

Sample No.	Station	Alignment	Offset (feet)	Depth Interval (feet)	AASHTO Class.	L.L.	P.I.	% by Weight				% Retained #4 Sieve	% Passing (sieves)			% Moisture	% Organic
								Coarse Sand	Fine Sand	Silt	Clay		#10	#40	#200		
S-006	92+00	-L-	65 RT	0.0 - 3.0	A-7-6 (7)	51	30	28.6	31.9	6.6	32.9	0	100	98	41	21.0	--
S-007	92+00	-L-	65 RT	3.5 - 6.0	A-2-6 (0)	34	16	39.7	38.8	2.9	18.6	0	100	86	22	--	--
S-008	102+00	-L-	81 LT	0.0 - 1.0	A-6 (3)	34	17	25.3	36.7	9.3	28.7	0	100	90	40	--	--
S-009	102+00	-L-	81 LT	1.0 - 5.0	A-7-6 (10)	52	27	20.9	31.1	9.1	38.9	0	100	93	50	25.0	--
S-010	102+00	-L-	81 LT	5.0 - 6.0	A-2-6 (0)	29	11	37.4	42.8	2.3	17.5	0	100	86	20	--	--
S-011	107+00	-L-	80 RT	0.0 - 1.0	A-4 (0)	24	10	22.8	41.7	12.4	23.1	0	100	92	38	23.0	--
S-012	107+00	-L-	80 RT	1.5 - 2.5	A-6 (3)	29	15	20.6	38.9	11.1	29.4	0	100	92	43	--	--
S-013	112+00	-L-	100 RT	0.0 - 0.5	A-4 (0)	NP	NP	7.4	10.7	78.5	3.4	14	82	95	84	--	27.4
S-014	112+00	-L-	100 RT	0.5 - 1.5	A-6 (3)	27	16	20.8	40.0	12.9	26.3	0	100	94	42	21.0	--
SS-039	111+93	-L-	70 RT	0.0 - 1.5	A-4 (3)	23	9	25.1	13.2	53.8	7.9	0	99	84	63	--	--
SS-040	111+93	-L-	70 RT	14.6 - 15.1	A-6 (8)	30	17	17.2	17.7	53.0	12.1	0	100	93	66	--	--
SS-041	111+93	-L-	70 RT	19.6 - 21.1	A-2-6 (0)	30	14	54.4	23.9	3.5	18.2	0	100	75	22	28.0	--
SS-042	111+93	-L-	70 RT	24.6 - 26.1	A-3 (0)	NP	NP	56.1	39.4	2.5	2.0	0	100	80	5	--	--
SS-043	111+93	-L-	70 RT	34.6 - 36.1	A-3 (0)	NP	NP	52.5	44.4	2.1	1.0	0	100	81	3	--	--
SS-044	111+93	-L-	70 RT	39.6 - 41.1	A-3 (0)	NP	NP	34.5	58.5	4.1	2.9	0	98	88	8	--	--
SS-045	122+00	-L-	103 RT	0.0 - 1.5	A-6 (1)	26	12	24.3	36.9	9.4	29.4	0	100	91	41	21.0	--
SS-046	122+00	-L-	103 RT	5.0 - 5.7	A-2-4 (0)	NP	NP	51.7	33.2	2.1	13.0	0	99	77	15	--	--
SS-047	122+00	-L-	103 RT	10.1 - 10.7	A-4 (0)	NP	NP	28.5	8.9	54.6	8.0	0	99	86	63	45.0	--
SS-048	122+00	-L-	103 RT	14.2 - 15.7	A-2-4 (0)	NP	NP	68.2	18.6	5.9	7.3	0	94	55	14	--	--
SS-049	127+00	-L-	CL	4.4 - 5.9	A-6 (1)	23	11	19.1	40.6	17.2	23.2	0	100	94	44	16.0	--
S-015	127+00	-L-	105 RT	0.0 - 1.0	A-4 (1)	20	8	21.8	30.9	21.2	26.1	0	100	91	50	17.0	--
S-016	127+00	-L-	105 RT	5.5 - 6.5	A-2-4 (0)	NP	NP	26.0	55.5	4.1	14.4	0	100	91	19	--	--
SS-050	132+00	-L-	CL	0.8 - 1.5	A-4 (0)	NP	NP	10.4	21.2	61.3	7.1	0	100	96	71	28.0	--
SS-051	132+00	-L-	CL	9.0 - 10.5	A-2-4 (0)	NP	NP	34.8	44.0	8.5	12.8	0	100	86	24	--	--
SS-052	132+00	-L-	CL	14.0 - 15.5	A-3 (0)	NP	NP	68.6	27.3	1.1	3.0	0	100	67	5	--	--
SS-053	132+00	-L-	CL	19.0 - 20.5	A-2-4 (0)	NP	NP	80.0	10.1	4.0	5.9	1	87	39	11	--	--
SS-054	137+00	-L-	CL	0.0 - 1.5	A-4 (4)	27	10	11.8	30.3	24.7	33.2	0	100	95	62	13.0	--
SS-055	137+00	-L-	CL	13.7 - 14.8	A-2-4 (0)	NP	NP	4.2	78.4	4.3	13.1	0	100	99	22	--	--
S-017	137+00	-L-	103 RT	0.0 - 1.0	A-4 (0)	NP	NP	18.7	45.5	25.4	10.4	0	100	93	41	--	13.2
S-018	137+00	-L-	103 RT	1.0 - 2.0	A-4 (1)	23	10	16.9	42.3	18.3	22.5	0	100	93	46	15.0	--
SS-056	142+00	-L-	CL	0.0 - 1.5	A-2-4 (0)	NP	NP	30.1	42.2	18.6	9.0	0	100	89	31	--	--
SS-057	142+00	-L-	CL	3.9 - 5.4	A-6 (3)	35	16	27.2	33.3	12.2	27.3	0	100	89	42	21.0	--
SS-058	142+00	-L-	CL	8.9 - 10.4	A-2-4 (0)	NP	NP	64.0	24.4	2.6	9.0	0	100	82	12	--	--
SS-059	142+00	-L-	CL	13.9 - 15.2	A-7-5 (18)	49	18	3.7	13.2	51.6	31.5	0	99	99	85	127.0	--
S-019	142+00	-L-	104 RT	2.0 - 3.0	A-7-6 (11)	46	33	18.3	38.0	10.8	32.9	0	100	93	48	24.0	--
SS-060	147+00	-L-	CL	8.6 - 9.4	A-7-6 (10)	48	32	17.9	37.9	8.8	35.5	0	100	94	47	26.0	--
S-020	147+00	-L-	86 RT	0.5 - 1.5	A-2-4 (0)	NP	NP	48.8	38.0	9.0	4.2	18	79	71	16	--	--
S-021	147+00	-L-	86 RT	2.0 - 3.0	A-2-6 (1)	30	15	31.3	43.7	6.6	18.5	0	100	88	27	--	--
S-022	147+00	-L-	86 RT	3.5 - 4.5	A-2-6 (1)	36	18	37.4	33.3	6.8	22.5	0	100	80	31	--	--
SS-128	152+00	-L-	CL	0.0 - 1.5	A-2-4 (0)	NP	NP	33.8	37.4	19.8	9.0	0	100	84	32	29.0	4.7

NP - NON-PLASTIC

Michael D. Kason
 Certified Lab Technician Signature

 Certification Number

LABORATORY TESTING SUMMARY

PROJECT NUMBER: 47533.1.2

TIP: I-5987A

COUNTY: ROBESON

DESCRIPTION: I-95 IMPROVEMENTS FROM SOUTH OF US 301 (EXIT 22) TO NORTH OF SR 1758 (McDUFFIE CROSSING RD.)

Sample No.	Station	Alignment	Offset (feet)	Depth Interval (feet)	AASHTO Class.	L.L.	P.I.	% by Weight				% Retained #4 Sieve	% Passing (sieves)			% Moisture	% Organic
								Coarse Sand	Fine Sand	Silt	Clay		#10	#40	#200		
SS-129	152+00	-L-	CL	4.9 - 6.4	A-2-4 (0)	NP	NP	35.2	46.9	5.4	12.5	0	100	81	21	--	--
SS-130	152+00	-L-	CL	9.9 - 11.4	A-7-6 (29)	71	49	20.8	19.0	36.8	23.5	0	99	83	64	--	--
SS-131	152+00	-L-	CL	14.9 - 16.4	A-6 (2)	31	16	25.7	34.6	15.8	23.9	2	92	92	41	32.0	--
SS-132	152+00	-L-	CL	19.9 - 21.4	A-3 (0)	NP	NP	79.3	17.0	1.2	2.5	0	99	37	4	--	--
SS-134	157+00	-L-	12 RT	5.0 - 6.5	A-7-6 (13)	53	32	24.6	24.8	8.6	42.0	0	100	86	53	32.0	--
S-023	157+00	-L-	91 RT	0.0 - 1.0	A-2-4 (0)	NP	NP	53.4	35.9	4.1	6.5	10	89	69	12	--	--
S-024	157+00	-L-	91 RT	1.5 - 2.5	A-2-4 (0)	25	4	37.7	42.7	3.2	16.4	0	100	84	21	--	--
S-025	157+00	-L-	91 RT	4.0 - 5.0	A-6 (5)	31	17	20.3	33.2	12.7	33.8	0	100	93	48	--	--
SS-135	162+00	-L-	CL	0.0 - 1.5	A-2-4 (0)	NP	NP	29.5	43.0	18.6	8.9	0	98	86	31	--	--
SS-136	162+00	-L-	CL	4.8 - 6.3	A-2-4 (0)	22	8	26.1	43.1	8.7	22.1	0	100	89	34	--	--
SS-137	162+00	-L-	CL	9.8 - 11.3	A-3 (0)	NP	NP	70.0	21.1	2.0	6.9	0	99	63	10	--	--
SS-138	162+00	-L-	CL	14.8 - 16.3	A-4 (0)	NP	NP	7.9	52.6	24.1	15.4	3	95	97	50	59.0	--
SS-139	162+00	-L-	CL	19.8 - 21.3	A-3 (0)	NP	NP	78.5	13.8	3.8	3.9	5	78	43	9	--	--
SS-141	167+00	-L-	1 RT	15.0 - 16.5	A-2-4 (0)	NP	NP	43.9	42.0	4.1	10.0	0	99	81	15	29.0	--
S-078	167+00	-L-	104 LT	2.0 - 3.0	A-6 (6)	27	14	19.1	16.5	55.6	8.9	0	100	90	65	--	--
S-079	167+00	-L-	104 LT	3.5 - 4.5	A-6 (10)	33	21	25.8	10.2	55.2	8.9	0	100	82	65	23.0	--
S-080	167+00	-L-	104 LT	5.5 - 6.0	A-6 (5)	37	23	24.6	36.5	15.1	23.8	0	100	87	42	--	--
S-026	167+00	-L-	117 RT	0.0 - 1.0	A-2-4 (0)	NP	NP	43.7	40.7	6.5	9.1	2	98	75	18	--	--
S-027	167+00	-L-	117 RT	2.0 - 3.0	A-6 (4)	34	21	26.3	34.4	14.9	24.4	7	93	89	42	13.0	--
S-028	167+00	-L-	117 RT	8.0 - 9.0	A-2-4 (0)	NP	NP	23.9	58.8	6.3	11.0	0	100	88	20	--	--
SS-143	172+00	-L-	1 RT	5.0 - 6.5	A-7-6 (9)	44	26	23.2	30.3	8.3	38.2	0	100	88	48	24.0	--
SS-144	172+00	-L-	1 RT	10.3 - 11.5	A-3 (0)	NP	NP	28.0	64.7	1.3	6.0	0	100	92	9	--	--
SS-145	172+00	-L-	1 RT	15.0 - 16.0	A-2-6 (1)	30	15	56.4	18.8	4.2	20.6	0	97	69	25	33.0	0.0
SS-146	172+00	-L-	1 RT	20.0 - 21.5	A-3 (0)	NP	NP	71.5	22.5	2.0	4.0	0	99	65	7	--	--
SS-147	177+00	-L-	CL	0.0 - 1.5	A-6 (7)	40	22	31.4	21.2	8.0	39.4	0	100	83	49	30.0	0.0
SS-148	177+00	-L-	CL	5.0 - 6.5	A-7-6 (14)	55	34	19.6	30.2	7.7	42.4	0	100	93	52	20.0	0.0
S-034	177+00	-L-	97 RT	0.0 - 3.0	A-2-4 (0)	25	7	16.9	54.1	7.5	21.5	0	100	94	31	--	--
S-035	177+00	-L-	97 RT	3.0 - 6.5	A-6 (6)	32	18	19.0	31.0	12.7	37.3	0	100	92	54	--	--
S-036	177+00	-L-	97 RT	6.5 - 9.0	A-6 (5)	38	23	28.2	32.9	10.0	28.8	0	100	89	41	--	--
SS-149	182+00	-L-	CL	0.0 - 1.5	A-2-4 (0)	19	4	35.1	41.0	7.1	16.8	0	98	83	26	--	--
SS-150	182+00	-L-	CL	5.2 - 6.7	A-7-6 (8)	52	33	13.4	46.6	2.6	37.4	0	100	96	42	19.0	--
SS-151	182+00	-L-	CL	10.2 - 11.7	A-2-4 (0)	NP	NP	27.1	58.2	1.7	13.0	0	100	92	15	--	--
SS-152	182+00	-L-	CL	15.2 - 16.7	A-2-4 (0)	27	9	45.1	33.2	3.6	18.1	0	100	84	22	--	--
S-030	182+00	-L-	102 RT	0.0 - 3.0	A-6 (4)	33	16	18.6	35.8	10.6	35.0	0	100	94	48	25.0	--
SS-011	197+00	-L-	2 RT	5.0 - 6.2	A-7-6 (5)	41	17	25.9	29.4	13.3	31.4	0	100	88	47	--	--
SS-012	197+00	-L-	2 RT	10.3 - 11.5	A-2-4 (0)	NP	NP	25.3	47.3	10.3	17.1	0	100	91	30	--	--
SS-013	197+00	-L-	2 RT	15.7 - 16.5	A-2-4 (0)	NP	NP	16.8	61.0	4.0	18.2	0	100	97	24	--	--
S-031	202+00	-L-	86 RT	0.0 - 6.0	A-6 (13)	32	19	8.4	15.2	59.9	16.5	0	100	97	78	21.0	--
SS-014	207+00	-L-	4 RT	0.3 - 1.8	A-2-4 (0)	NP	NP	55.6	31.0	4.4	9.0	0	99	67	16	--	--
SS-015	207+00	-L-	4 RT	5.2 - 6.7	A-6 (7)	40	21	25.8	26.7	16.0	21.4	0	100	86	52	--	--

NP - NON-PLASTIC

 Certified Lab Technician Signature

 Certification Number

LABORATORY TESTING SUMMARY

PROJECT NUMBER: 47533.1.2

TIP: I-5987A

COUNTY: ROBESON

DESCRIPTION: I-95 IMPROVEMENTS FROM SOUTH OF US 301 (EXIT 22) TO NORTH OF SR 1758 (McDUFFIE CROSSING RD.)

Sample No.	Station	Alignment	Offset (feet)	Depth Interval (feet)	AASHTO Class.	L.L.	P.I.	% by Weight				% Retained #4 Sieve	% Passing (sieves)			% Moisture	% Organic
								Coarse Sand	Fine Sand	Silt	Clay		#10	#40	#200		
SS-016	207+00	-L-	4 RT	10.8 - 11.7	A-7-6 (12)	43	24	7.4	35.2	18.9	38.5	0	100	98	61	18.0	--
S-029	217+00	-L-	116 RT	0.0 - 6.0	A-2-6 (1)	29	14	48.7	17.7	9.3	24.4	0	99	67	35	19.0	--
SS-017	222+00	-L-	8 RT	0.0 - 1.5	A-2-4 (0)	21	5	18.7	53.4	7.7	20.1	0	100	93	30	--	--
SS-018	222+00	-L-	8 RT	4.7 - 6.2	A-6 (7)	39	20	21.8	28.6	11.1	38.5	0	100	89	53	--	--
SS-019	222+00	-L-	8 RT	10.3 - 11.2	A-3 (0)	NP	NP	57.4	36.6	2.1	3.9	0	99	69	7	--	--
SS-020	222+00	-L-	8 RT	14.7 - 15.2	A-2-4 (0)	25	7	10.8	61.0	6.0	22.3	0	100	97	30	--	--
SS-021	227+00	-L-	9 RT	0.0 - 1.5	A-4 (0)	21	6	19.3	31.3	28.3	21.1	0	100	89	53	17.0	3.9
SS-022	227+00	-L-	9 RT	9.6 - 11.1	A-2-4 (0)	23	5	30.3	47.9	3.0	18.9	0	100	91	23	--	--
SS-023	227+00	-L-	9 RT	14.6 - 16.1	A-2-4 (0)	NP	NP	35.3	46.7	12.2	5.8	0	100	96	20	--	1.6
S-037	227+00	-L-	96 LT	0.0 - 4.0	A-2-4 (0)	18	1	52.1	30.3	17.0	0.6	11	87	67	19	--	--
S-038	227+00	-L-	96 LT	4.0 - 7.0	A-4 (1)	19	8	21.8	31.9	23.4	22.9	2	98	89	50	--	--
SS-024	232+00	-L-	10 RT	1.0 - 1.5	A-2-4 (0)	NP	NP	29.5	51.3	13.3	5.9	0	100	85	23	--	--
SS-025	232+00	-L-	10 RT	4.6 - 6.1	A-7-6 (6)	42	28	14.5	46.0	5.2	34.3	0	100	95	41	--	--
SS-026	232+00	-L-	10 RT	9.8 - 11.3	A-2-4 (0)	22	7	30.2	45.8	4.7	19.2	0	99	90	25	--	--
SS-027	232+00	-L-	10 RT	14.8 - 16.3	A-2-4 (0)	NP	NP	38.9	43.6	9.7	7.8	0	96	86	19	--	1.3
SS-028	232+00	-L-	10 RT	19.8 - 21.3	A-2-4 (0)	NP	NP	59.3	28.2	7.1	5.4	4	89	62	14	--	--
SS-029	242+00	-L-	12 RT	0.0 - 1.5	A-6 (2)	31	12	39.4	21.5	19.8	19.3	0	100	76	42	18.0	5.2
SS-030	242+00	-L-	12 RT	4.7 - 6.2	A-7-6 (18)	60	36	29.9	14.2	10.6	45.3	0	100	82	58	--	--
SS-031	242+00	-L-	12 RT	10.0 - 11.5	A-2-4 (0)	NP	NP	74.0	16.2	0.8	9.0	0	99	53	10	--	--
SS-032	242+00	-L-	12 RT	20.0 - 21.5	A-2-4 (0)	NP	NP	68.7	18.4	8.9	4.1	0	99	53	14	--	1.1
S-039	247+00	-L-	92 LT	0.0 - 5.0	A-2-4 (0)	NP	NP	60.1	25.4	5.0	9.5	4	94	61	16	--	--
S-040	247+00	-L-	92 LT	5.0 - 6.0	A-7-6 (6)	46	28	16.9	44.7	3.3	35.0	0	100	94	40	--	--
S-041	247+00	-L-	92 LT	6.0 - 8.0	A-2-4 (0)	NP	NP	41.5	35.8	8.1	14.6	0	100	76	26	--	--
SS-033	252+00	-L-	12 RT	0.0 - 1.5	A-4 (0)	NP	NP	13.1	14.3	64.3	8.2	0	100	82	74	29.0	6.7
SS-034	252+00	-L-	12 RT	4.7 - 6.2	A-2-4 (0)	21	4	36.5	43.7	6.7	13.1	0	100	80	22	--	--
SS-035	252+00	-L-	12 RT	14.8 - 16.3	A-2-4 (0)	NP	NP	26.0	54.2	3.8	16.0	0	100	93	21	--	--
S-042	251+99	-L-	88 LT	4.0 - 5.0	A-4 (0)	NP	NP	16.9	28.0	44.2	10.8	1	98	92	58	--	16.0
S-088	252+01	-L-	117 RT	3.5 - 4.0	A-2-4 (0)	NP	NP	29.0	38.7	14.7	17.6	0	100	88	35	--	7.3
S-206	252+01	-L-	117 RT	4.5 - 5.5	A-2-4 (0)	18	5	40.4	33.6	9.9	16.1	0	100	79	28	--	--
S-032	256+99	-L-	88 LT	0.0 - 6.0	A-2-6 (0)	26	11	23.7	46.9	9.7	19.8	0	100	91	32	15.0	--
SS-036	262+00	-L-	CL	0.0 - 1.5	A-4 (0)	23	6	16.5	49.1	15.2	19.2	0	100	94	37	22.0	--
SS-037	262+00	-L-	CL	5.1 - 6.6	A-2-4 (0)	NP	NP	17.9	63.6	7.3	11.1	0	100	94	20	--	--
SS-038	262+00	-L-	CL	10.1 - 11.6	A-2-4 (0)	NP	NP	16.8	64.5	4.6	14.1	0	100	95	20	--	--
S-043	267+00	-L-	87 LT	0.0 - 2.0	A-4 (0)	14	3	20.9	43.5	18.7	16.9	0	100	92	38	--	--
S-044	267+00	-L-	87 LT	2.0 - 6.0	A-6 (2)	25	12	22.2	37.6	13.5	26.8	0	100	90	44	--	--
S-203	277+00	-L-	81 RT	0.5 - 1.5	A-6 (2)	25	13	22.7	31.8	18.0	27.5	0	100	88	47	12.0	--
S-204	277+00	-L-	81 RT	3.0 - 4.0	A-6 (1)	24	13	28.2	36.6	11.9	23.4	0	100	86	36	--	--
S-205	277+00	-L-	81 RT	4.5 - 5.5	A-2-4 (0)	20	8	33.3	37.3	11.4	18.0	0	100	84	31	--	--
SS-061	297+00	-L-	91 RT	0.0 - 1.5	A-2-4 (0)	NP	NP	30.5	45.4	9.0	15.1	0	100	84	26	--	--
SS-062	297+00	-L-	91 RT	4.5 - 5.5	A-6 (2)	26	14	28.2	33.8	13.8	24.1	0	100	84	40	14.0	--

NP - NON-PLASTIC

Michael D. Kason
 Certified Lab Technician Signature

 Certification Number

LABORATORY TESTING SUMMARY

PROJECT NUMBER: 47533.1.2

TIP: I-5987A

COUNTY: ROBESON

DESCRIPTION: I-95 IMPROVEMENTS FROM SOUTH OF US 301 (EXIT 22) TO NORTH OF SR 1758 (McDUFFIE CROSSING RD.)

Sample No.	Station	Alignment	Offset (feet)	Depth Interval (feet)	AASHTO Class.	L.L.	P.I.	% by Weight				% Retained #4 Sieve	% Passing (sieves)			% Moisture	% Organic
								Coarse Sand	Fine Sand	Silt	Clay		#10	#40	#200		
SS-063	297+00	-L-	91 RT	9.5 - 11.0	A-4 (0)	23	5	1.5	65.7	3.6	29.2	0	100	99	35	--	--
SS-064	297+00	-L-	91 RT	14.5 - 15.6	A-7-6 (32)	55	33	2.6	12.1	23.5	61.9	0	100	99	89	65.0	--
SS-065	297+00	-L-	91 RT	19.5 - 21.0	A-2-4 (0)	NP	NP	55.9	20.8	9.6	13.7	0	97	69	24	28.0	--
SS-066	302+00	-L-	81 RT	4.7 - 6.2	A-2-6 (0)	29	15	79.0	8.9	3.1	8.9	0	99	33	12	--	--
SS-067	302+00	-L-	81 RT	24.7 - 26.2	A-7-6 (43)	66	41	4.0	5.8	34.5	55.7	0	100	98	93	32.0	--
SS-068	307+00	-L-	111 RT	0.0 - 1.5	A-4 (0)	24	7	21.6	42.9	19.1	16.4	0	100	89	37	41.0	4.4
SS-069	307+00	-L-	111 RT	4.0 - 5.2	A-7-6 (39)	68	41	1.6	16.9	26.5	55.0	0	100	99	85	39.0	--
SS-070	307+00	-L-	111 RT	10.2 - 11.2	A-2-4 (0)	NP	NP	60.6	35.4	2.6	0.0	0	98	64	20	--	--
SS-071	307+00	-L-	111 RT	13.7 - 15.2	A-3 (0)	NP	NP	62.0	35.4	2.6	0.0	0	100	78	3	--	--
SS-072	307+00	-L-	111 RT	18.7 - 20.2	A-2-6 (0)	31	17	65.3	14.4	8.5	11.8	1	90	53	21	--	--
SS-073	307+00	-L-	111 RT	23.7 - 25.2	A-6 (16)	38	21	2.2	20.1	23.3	54.4	0	100	99	82	21.0	--
SS-087	317+00	-L-	79 LT	4.8 - 6.3	--	--	--	--	--	--	--	--	--	--	--	--	7.1
SS-084	322+00	-L-	77 LT	4.7 - 6.2	A-6 (1)	28	11	8.7	57.3	8.8	25.2	0	100	98	37	39.0	--
SS-085	322+00	-L-	77 LT	9.7 - 11.2	A-6 (4)	33	13	15.8	33.0	19.7	31.5	0	100	96	54	--	--
SS-086	322+00	-L-	77 LT	14.7 - 16.2	A-3 (0)	NP	NP	63.5	27.0	4.5	5.0	0	99	73	10	--	--
SS-081	332+00	-L-	89 LT	5.0 - 6.5	A-7-5 (45)	75	39	1.8	3.7	38.8	55.8	0	100	99	96	55.0	--
SS-082	332+00	-L-	89 LT	10.0 - 11.5	A-2-6 (0)	34	13	61.3	10.6	14.4	13.7	16	71	54	29	--	--
SS-083	332+00	-L-	89 LT	20.0 - 21.5	A-6 (5)	38	19	36.5	20.6	16.0	26.9	0	88	78	45	--	--
SS-079	342+00	-L-	79 LT	4.9 - 6.4	A-6 (16)	40	21	6.7	16.6	30.3	46.4	0	100	94	79	18.0	--
SS-080	342+00	-L-	79 LT	14.9 - 16.4	A-2-4 (0)	NP	NP	48.6	36.6	3.9	10.9	0	98	75	15	--	--
SS-077	353+00	-L-	96 LT	5.0 - 6.5	A-6 (9)	37	23	21.1	26.0	14.4	38.5	0	100	91	55	32.0	--
SS-078	353+00	-L-	96 LT	10.0 - 11.5	A-2-4 (0)	22	8	64.6	13.8	5.9	15.7	1	99	65	23	--	--
SS-252C	363+00	-L-	81 RT	3.7 - 5.2	A-2-4 (0)	NP	NP	45.6	40.6	2.6	11.2	0	100	83	15	--	--
SS-253C	363+00	-L-	81 RT	8.7 - 10.2	A-2-4 (0)	NP	NP	36.5	32.4	8.6	22.5	0	96	86	32	--	--
SS-254	363+00	-L-	81 RT	18.7 - 20.2	A-2-4 (0)	NP	NP	56.4	32.5	2.9	8.2	0	100	56	12	--	--
S-099	368+00	-L-	91 RT	0.0 - 0.5	A-4 (0)	23	5	17.0	41.6	12.2	29.2	0	100	94	48	--	4.5
SS-074	373+00	-L-	83 LT	5.0 - 6.5	A-7-6 (17)	53	40	14.8	38.8	14.9	31.6	0	100	91	55	29.0	--
SS-075	373+00	-L-	83 LT	14.6 - 16.1	A-7-5 (14)	51	20	12.5	21.7	35.1	30.7	0	100	95	68	--	--
SS-076	373+00	-L-	83 LT	19.6 - 20.1	A-3 (0)	NP	NP	85.1	11.8	2.5	0.6	0	91	39	3	--	--
SS-010	378+00	-L-	79 LT	19.9 - 21.4	A-6 (13)	37	18	9.5	19.4	24.5	46.6	0	100	95	76	--	--
SS-008C	383+00	-L-	89 LT	0.0 - 1.5	A-6 (6)	39	20	34.8	19.7	18.4	27.0	0	99	76	50	--	--
SS-009C	383+00	-L-	89 LT	10.0 - 11.5	A-3 (0)	NP	NP	87.4	9.0	2.7	1.0	0	98	47	4	--	--
SS-005C	393+00	-L-	78 LT	0.5 - 1.5	A-6 (3)	31	14	40.5	16.9	13.4	29.1	0	99	74	45	--	--
SS-006C	393+00	-L-	78 LT	9.9 - 11.4	A-3 (0)	NP	NP	77.8	16.5	4.0	1.0	0	95	44	6	--	--
SS-007C	393+00	-L-	78 LT	14.9 - 16.4	A-2-4 (0)	NP	NP	41.0	48.2	3.2	7.6	0	99	84	12	--	--
SS-001C	402+00	-L-	93 LT	0.0 - 1.5	A-2-4 (0)	NP	NP	45.1	24.3	15.4	15.2	0	99	70	33	--	--
SS-002C	402+00	-L-	93 LT	4.9 - 6.4	A-2-7 (2)	43	25	57.0	17.3	4.5	21.2	0	99	64	26	--	--
SS-003C	402+00	-L-	93 LT	9.9 - 11.4	A-2-4 (0)	NP	NP	12.2	79.1	2.5	6.2	0	100	96	10	--	--
SS-004C	402+00	-L-	93 LT	14.9 - 16.4	A-2-4 (0)	NP	NP	33.5	48.7	6.9	10.8	0	98	89	19	--	--
S-160	407+00	-L-	2 RT	4.5 - 5.0	A-2-6 (1)	38	21	53.9	21.6	6.1	18.4	0	99	62	26	--	--

NP - NON-PLASTIC

Certified Lab Technician Signature

Certification Number

LABORATORY TESTING SUMMARY

PROJECT NUMBER: 47533.1.2

TIP: I-5987A

COUNTY: ROBESON

DESCRIPTION: I-95 IMPROVEMENTS FROM SOUTH OF US 301 (EXIT 22) TO NORTH OF SR 1758 (McDUFFIE CROSSING RD.)

Sample No.	Station	Alignment	Offset (feet)	Depth Interval (feet)	AASHTO Class.	L.L.	P.I.	% by Weight				% Retained #4 Sieve	% Passing (sieves)			% Moisture	% Organic
								Coarse Sand	Fine Sand	Silt	Clay		#10	#40	#200		
SS-088	407+00	-L-	77 RT	4.8 - 6.3	A-2-7 (3)	48	30	56.6	13.0	4.8	25.6	1	99	63	31	--	--
SS-089	407+00	-L-	77 RT	9.8 - 11.3	A-3 (0)	NP	NP	45.6	47.8	2.6	4.0	0	99	79	7	--	--
S-161	412+00	-L-	2 RT	1.0 - 1.5	A-2-4 (0)	NP	NP	54.4	27.8	4.5	13.3	2	98	69	20	--	--
S-162	412+00	-L-	2 RT	2.5 - 3.5	A-7-6 (9)	46	25	30.8	19.6	10.6	39.0	1	99	80	52	--	--
SS-090	417+00	-L-	92 RT	4.9 - 6.4	A-7-6 (6)	43	25	37.1	22.9	11.0	29.0	0	100	78	43	--	--
SS-091	417+00	-L-	92 RT	9.9 - 11.4	A-2-6 (1)	30	16	44.6	24.6	8.1	22.7	0	98	71	33	17.0	--
SS-095	427+00	-L-	76 RT	4.9 - 6.4	A-6 (4)	38	20	39.6	22.6	10.2	27.6	0	99	74	42	18.0	--
SS-096	427+00	-L-	76 RT	9.9 - 11.4	A-7-6 (15)	51	33	21.3	28.5	13.9	36.3	0	100	86	56	--	--
SS-097	427+00	-L-	76 RT	14.9 - 16.4	A-2-4 (0)	NP	NP	1.1	78.9	5.0	15.1	0	100	100	23	--	--
SS-098	427+00	-L-	76 RT	19.9 - 21.4	A-3 (0)	NP	NP	21.8	70.0	3.2	5.0	0	99	99	9	--	--
SS-092	437+00	-L-	105 RT	4.9 - 6.4	A-2-4 (0)	23	6	61.7	19.4	4.0	15.0	0	99	82	64	--	--
SS-093	437+00	-L-	105 RT	9.9 - 11.4	A-7-6 (18)	54	31	24.6	15.4	11.5	48.5	0	100	82	64	--	--
SS-094	437+00	-L-	105 RT	19.9 - 21.4	A-2-4 (0)	NP	NP	1.1	85.8	2.1	11.0	0	100	100	14	--	--
S-163	442+00	-L-	2 RT	0.5 - 1.0	A-2-4 (0)	NP	NP	50.0	35.8	5.8	8.3	0	100	76	17	--	--
S-164	442+00	-L-	2 RT	3.0 - 3.5	A-6 (5)	38	22	37.8	23.5	12.2	26.5	0	99	74	42	--	--
S-165	442+00	-L-	2 RT	5.0 - 5.5	A-2-6 (1)	33	19	51.7	24.6	6.2	17.4	0	99	64	26	--	--
S-166	442+00	-L-	2 RT	9.5 - 10.0	A-2-4 (0)	NP	NP	74.1	14.1	0.6	11.2	0	97	40	13	--	--
SS-300	447+00	-L-	78 LT	3.3 - 4.8	A-2-6 (2)	34	17	47.5	19.2	8.1	25.2	0	98	68	36	--	--
S-168	472+00	-L-	88 LT	0.5 - 1.0	A-2-4 (0)	23	8	64.0	18.3	2.8	14.9	0	96	54	20	--	--
S-169	472+00	-L-	88 LT	2.0 - 2.5	A-2-6 (2)	36	14	56.3	15.4	7.0	21.3	0	98	62	30	--	--
S-170	472+00	-L-	88 LT	3.5 - 4.0	A-2-7 (0)	42	26	77.8	18.7	26.2	29.7	0	99	36	6	--	--
S-167	477+00	-L-	87 LT	2.0 - 2.5	A-4 (1)	29	10	32.7	29.0	17.8	20.5	0	99	81	44	--	6.7
S-089	477+00	-L-	92 RT	0.0 - 4.0	A-3 (0)	NP	NP	55.9	35.7	3.3	5.1	0	99	60	10	--	--
S-090	477+00	-L-	92 RT	4.0 - 6.0	A-2-6 (1)	31	16	40.1	29.8	9.9	20.2	0	100	74	33	--	--
S-171	482+00	-L-	78 LT	1.0 - 1.5	A-2-4 (0)	NP	NP	55.2	29.2	3.7	11.9	0	99	69	18	--	--
S-172	482+00	-L-	78 LT	2.0 - 2.5	A-2-4 (0)	NP	NP	55.2	30.2	5.7	9.0	0	99	68	17	--	--
S-173	482+00	-L-	78 LT	3.0 - 3.5	A-2-6 (1)	33	14	50.9	19.1	8.2	21.8	0	98	67	32	--	--
S-174	482+00	-L-	78 LT	5.5 - 6.0	A-2-4 (0)	30	9	71.1	14.1	2.0	12.8	0	97	48	15	--	--
S-091	487+00	-L-	87 RT	0.0 - 1.0	A-2-4 (0)	NP	NP	45.5	31.4	10.9	12.2	0	99	73	26	--	--
S-092	487+00	-L-	87 RT	1.0 - 6.0	A-2-6 (2)	34	19	40.8	27.0	8.0	24.2	0	100	76	35	--	--
S-093	492+00	-L-	92 RT	1.0 - 8.0	A-7-6 (8)	43	28	33.7	22.4	13.7	30.2	0	100	79	47	--	--
S-207	36+59	-SR2-	CL	1.0 - 2.0	A-6 (2)	32	14	29.6	30.2	10.8	29.4	0	100	83	42	--	--
S-208	36+59	-SR2-	CL	3.0 - 4.0	A-2-4 (0)	23	10	34.9	32.3	12.8	20.0	1	99	79	35	--	--
S-209	36+59	-SR2-	CL	6.5 - 7.5	A-2-4 (0)	21	8	37.2	32.0	11.1	19.8	1	99	78	33	--	--
S-210	19+08	-SR2-	29 RT	1.5 - 2.5	A-2-4 (0)	22	8	44.9	29.8	7.3	18.0	0	100	68	28	--	--
S-211	19+08	-SR2-	29 RT	4.5 - 5.5	A-2-6 (1)	30	15	50.5	25.6	4.9	19.0	0	100	65	25	--	--
S-212	19+08	-SR2-	29 RT	6.0 - 7.0	A-2-4 (0)	21	6	76.1	10.5	2.5	10.9	0	99	46	14	--	--
S-112	19+55	-Y1A-	25 RT	1.5 - 3.5	A-2-4 (0)	NP	NP	22.3	46.4	15.2	16.1	0	100	89	34	--	--
S-113	19+55	-Y1A-	25 RT	3.5 - 6.0	A-2-4 (0)	23	9	29.5	38.5	11.5	20.5	0	100	84	34	--	--
SS-104	27+02	-Y1A-	4 RT	0.0 - 1.5	A-4 (1)	21	7	7.2	45.4	24.7	22.7	0	100	99	50	18.0	--

NP - NON-PLASTIC

Michael D. Kason
 Certified Lab Technician Signature

 Certification Number

LABORATORY TESTING SUMMARY

PROJECT NUMBER: 47533.1.2

TIP: I-5987A

COUNTY: ROBESON

DESCRIPTION: I-95 IMPROVEMENTS FROM SOUTH OF US 301 (EXIT 22) TO NORTH OF SR 1758 (McDUFFIE CROSSING RD.)

Sample No.	Station	Alignment	Offset (feet)	Depth Interval (feet)	AASHTO Class.	L.L.	P.I.	% by Weight				% Retained #4 Sieve	% Passing (sieves)			% Moisture	% Organic
								Coarse Sand	Fine Sand	Silt	Clay		#10	#40	#200		
SS-105	27+02	-Y1A-	4 RT	4.4 - 5.9	A-6 (1)	24	11	15.3	46.0	13.7	25.1	0	100	96	40	--	--
SS-106	27+02	-Y1A-	4 RT	10.2 - 10.9	A-2-4 (0)	NP	NP	4.3	83.1	4.2	8.4	0	100	99	14	--	--
SS-107	27+02	-Y1A-	4 RT	14.4 - 15.9	A-2-4 (0)	NP	NP	44.5	32.1	7.1	16.4	0	100	81	25	--	--
SS-108	33+06	-Y1A-	15 RT	0.0 - 1.5	A-4 (0)	21	7	23.9	38.9	20.1	17.1	0	100	89	39	--	--
SS-109	33+06	-Y1A-	15 RT	3.4 - 4.9	A-2-6 (1)	29	13	33.8	33.7	5.7	26.8	0	100	85	33	--	--
SS-110	33+06	-Y1A-	15 RT	8.4 - 9.9	A-2-4 (0)	NP	NP	19.1	63.6	4.8	12.6	0	100	91	19	--	--
SS-111	33+06	-Y1A-	15 RT	13.4 - 14.9	A-7-6 (18)	48	27	10.4	21.9	14.8	52.9	0	100	96	70	--	--
SS-112	33+06	-Y1A-	15 RT	23.4 - 24.9	A-3 (0)	NP	NP	32.9	60.1	1.4	5.6	0	100	86	9	--	--
SS-113	33+06	-Y1A-	15 RT	28.4 - 29.9	A-7-6 (23)	48	25	3.1	16.0	30.4	50.5	0	100	98	87	--	--
SS-114	44+16	-Y1A-	23 LT	0.0 - 1.5	A-2-4 (0)	19	6	34.3	36.4	9.6	19.7	0	100	81	31	--	--
SS-116	44+16	-Y1A-	23 LT	10.2 - 10.9	A-2-4 (0)	NP	NP	64.9	24.2	1.4	9.5	1	99	71	11	--	--
SS-117	44+16	-Y1A-	23 LT	19.4 - 20.9	A-2-4 (0)	20	5	52.4	25.4	3.7	18.5	0	99	75	23	--	--
SS-118	44+16	-Y1A-	23 LT	24.4 - 25.9	A-3 (0)	NP	NP	81.7	13.5	2.4	2.5	0	98	45	5	--	--
SS-119	44+16	-Y1A-	23 LT	34.4 - 35.9	A-7-5 (17)	56	24	8.3	30.9	37.7	23.2	0	100	95	68	--	--
SS-120	44+16	-Y1A-	23 LT	44.4 - 45.9	A-2-7 (28)	56	25	2.8	7.0	36.0	54.2	0	100	98	93	--	--
SS-121	50+30	-Y1A-	29 RT	0.0 - 1.5	A-2-4 (0)	22	9	31.1	36.0	12.2	20.6	0	100	84	34	--	--
SS-122	50+30	-Y1A-	29 RT	4.1 - 5.6	A-2-4 (0)	24	7	57.1	22.9	2.4	17.6	0	100	79	20	--	--
SS-123	50+30	-Y1A-	29 RT	9.1 - 10.6	A-7-6 (47)	70	49	2.5	11.3	23.9	62.3	0	100	99	88	--	--
SS-124	25+87	-Y1RPA-	8 RT	0.0 - 1.5	A-4 (0)	25	10	21.7	43.6	11.1	23.6	0	100	92	36	--	--
SS-125	25+87	-Y1RPA-	8 RT	8.5 - 10.0	A-2-4 (0)	NP	NP	6.6	73.9	3.9	15.6	0	100	97	21	--	--
SS-126	25+87	-Y1RPA-	8 RT	13.5 - 15.0	A-7-6 (26)	56	31	10.5	11.0	24.3	54.2	0	100	95	80	--	--
SS-127	25+87	-Y1RPA-	8 RT	23.5 - 25.0	A-3 (0)	NP	NP	55.0	38.4	5.1	1.5	0	98	73	7	--	--
S-114	16+50	-Y1ARPB-	CL	1.5 - 2.5	A-2-6 (1)	28	15	28.1	41.7	7.7	22.5	0	100	88	32	--	--
SS-166	19+87	-Y2-	19 RT	1.1 - 1.5	A-6 (8)	31	17	16.6	22.0	23.6	37.8	0	100	90	65	--	--
SS-167	19+87	-Y2-	19 RT	8.6 - 10.1	A-6 (2)	36	21	16.4	49.5	8.6	25.3	0	100	96	36	--	--
SS-168	19+87	-Y2-	19 RT	13.6 - 15.1	A-2-4 (0)	NP	NP	7.9	77.4	3.1	11.6	0	100	99	15	--	--
SS-169	19+87	-Y2-	19 RT	18.6 - 20.1	A-2-4 (0)	NP	NP	53.8	27.9	9.3	9.0	0	97	66	20	--	--
SS-170	19+87	-Y2-	19 RT	23.6 - 25.1	A-2-4 (0)	NP	NP	47.4	38.2	8.8	5.5	0	100	85	16	--	--
SS-171	22+53	-Y2-	57 RT	3.3 - 4.8	A-4 (0)	19	4	30.0	29.4	22.2	18.4	0	100	82	45	--	4.2
SS-172	24+79	-Y2-	32 LT	0.0 - 1.5	A-4 (0)	17	5	21.1	30.9	27.7	20.3	0	100	89	53	--	--
SS-173	24+79	-Y2-	32 LT	8.6 - 10.1	A-2-6 (0)	24	11	50.9	26.3	6.7	16.2	0	99	66	25	--	--
SS-174	24+79	-Y2-	32 LT	18.6 - 20.1	A-2-4 (0)	NP	NP	37.9	43.2	5.7	13.3	0	100	81	20	--	--
SS-175	24+79	-Y2-	32 LT	23.6 - 25.1	A-2-4 (0)	NP	NP	63.6	26.9	5.3	4.1	0	98	61	10	--	--
SS-176	24+79	-Y2-	32 LT	33.6 - 35.1	A-3 (0)	NP	NP	62.0	9.7	2.8	25.5	1	98	84	5	--	--
SS-321	24+79	-Y2-	32 LT	38.6 - 40.1	A-2-6 (1)	30	16	62.0	9.7	2.8	25.5	0	100	63	30	--	--
SS-177	24+79	-Y2-	32 LT	43.6 - 45.1	A-2-4 (0)	NP	NP	52.0	31.9	3.1	12.9	0	99	76	17	--	--
SS-178	33+84	-Y2-	59 RT	0.0 - 1.5	A-2-4 (0)	19	6	30.1	39.7	12.1	18.1	0	100	85	34	--	--
SS-179	33+84	-Y2-	59 RT	3.5 - 5.0	A-6 (2)	35	17	35.0	31.0	8.8	25.3	0	100	82	38	--	--
SS-180	33+84	-Y2-	59 RT	13.5 - 15.0	A-4 (1)	25	9	14.5	43.6	23.7	18.3	0	100	95	47	--	--
SS-181	33+84	-Y2-	59 RT	23.5 - 25.0	A-3 (0)	NP	NP	84.9	8.0	2.2	4.9	0	97	31	8	--	--

NP - NON-PLASTIC

 Certified Lab Technician Signature

 Certification Number

NORTH CAROLINA DEPARTMENT OF TRANSPORTATION
DIVISION OF HIGHWAYS
GEOTECHNICAL ENGINEERING UNIT
SUBSURFACE INVESTIGATION

APPENDIX B

TERRACON CPT LOGS

CATLIN CPT LOGS

REFERENCE: I-5987A

PROJECT: 47533.1.1

Prepared in the Office of:

Terracon

Consulting Engineers and Scientists
2401 BRENTWOOD ROAD, SUITE 107
RALEIGH, NORTH CAROLINA 27604
NC REGISTERED ENGINEERING FIRM: F-0869
NC REGISTERED GEOLOGIC FIRM: C-367

CPT GENERAL NOTES

DESCRIPTION OF MEASUREMENTS AND CALIBRATIONS

To be reported per ASTM D5778:

Uncorrected Tip Resistance, q_c
Measured force acting on the cone divided by the cone's projected area

Corrected Tip Resistance, q_t
Cone resistance corrected for porewater and net area ratio effects
 $q_t = q_c + u_2(1 - a)$

Where a is the net area ratio, a lab calibration of the cone typically between 0.70 and 0.85

Pore Pressure, u
Pore pressure measured during penetration
 u_1 - sensor on the face of the cone
 u_2 - sensor on the shoulder (more common)

Sleeve Friction, f_s
Frictional force acting on the sleeve divided by its surface area

Normalized Friction Ratio, F_r
The ratio as a percentage of f_s to q_t , accounting for overburden pressure

To be reported per ASTM D7400, if collected:

Shear Wave Velocity, V_s
Measured in a Seismic CPT and provides direct measure of soil stiffness

DESCRIPTION OF GEOTECHNICAL CORRELATIONS

Normalized Tip Resistance, Q_{tn}
 $Q_{tn} = ((q_t - \sigma_{v0})/P_a)(P_a/\sigma_{v0})^n$
 $n = 0.381(I_c) + 0.05(\sigma_{v0}/P_a) - 0.15$

Over Consolidation Ratio, OCR
OCR (1) = $0.25(Q_{tn})^{1.25}$
OCR (2) = $0.33(Q_{tn})$

Undrained Shear Strength, S_u
 $S_u = Q_{tn} \times \sigma_{v0}/N_{60}$
 N_{60} is a soil-specific factor (shown on S_u plot)

Sensitivity, S_t
 $S_t = (q_t - \sigma_{v0}/N_{60}) \times (1/f_s)$

Effective Friction Angle, ϕ'
 $\phi' (1) = \tan^{-1}(0.373[\log(q_t/\sigma_{v0}) + 0.29])$
 $\phi' (2) = 17.6 + 11[\log(Q_{tn})]$

Unit Weight, γ
 $\gamma = (0.27[\log(F_r)] + 0.36[\log(q_t/atm)] + 1.236) \times \gamma_{water}$
 σ_{v0} is taken as the incremental sum of the unit weights

Small Strain Shear Modulus, G_0
 $G_0 (1) = \rho V_s^2$
 $G_0 (2) = 0.015 \times 10^{(0.55I_c + 1.68)}(q_t - \sigma_{v0})$

Soil Behavior Type Index, I_c
 $I_c = [(3.47 - \log(Q_{tn}))^2 + (\log(F_r) + 1.22)^2]^{0.5}$

SPT N_{60}
 $N_{60} = (q_t/atm) / 10^{(1.1268 - 0.2817I_c)}$

Elastic Modulus, E_s (assumes $q_t/q_{t,lim} \sim 0.3$, i.e. FS = 3)
 $E_s (1) = 2.6\psi G_0$ where $\psi = 0.56 - 0.33\log(Q_{tn, clean sand})$
 $E_s (2) = G_0$
 $E_s (3) = 0.015 \times 10^{(0.55I_c + 1.68)}(q_t - \sigma_{v0})$
 $E_s (4) = 2.5q_t$

Constrained Modulus, M
 $M = \alpha_M(q_t - \sigma_{v0})$
For $I_c > 2.2$ (fine-grained soils)
 $\alpha_M = Q_{tn}$ with maximum of 14
For $I_c < 2.2$ (coarse-grained soils)
 $\alpha_M = 0.0188 \times 10^{(0.55I_c + 1.68)}$

Hydraulic Conductivity, k
For $1.0 < I_c < 3.27$ $k = 10^{(0.952 - 3.04I_c)}$
For $3.27 < I_c < 4.0$ $k = 10^{(-4.52 - 1.37I_c)}$

Relative Density, D_r
 $D_r = (Q_{tn} / 350)^{0.5} \times 100$

REPORTED PARAMETERS

CPT logs as provided, at a minimum, report the data as required by ASTM D5778 and ASTM D7400 (if applicable). This minimum data include q_t , f_s , and u . Other correlated parameters may also be provided. These other correlated parameters are interpretations of the measured data based upon published and reliable references, but they do not necessarily represent the actual values that would be derived from direct testing to determine the various parameters. To this end, more than one correlation to a given parameter may be provided. The following chart illustrates estimates of reliability associated with correlated parameters based upon the literature referenced below.

RELATIVE RELIABILITY OF CPT CORRELATIONS

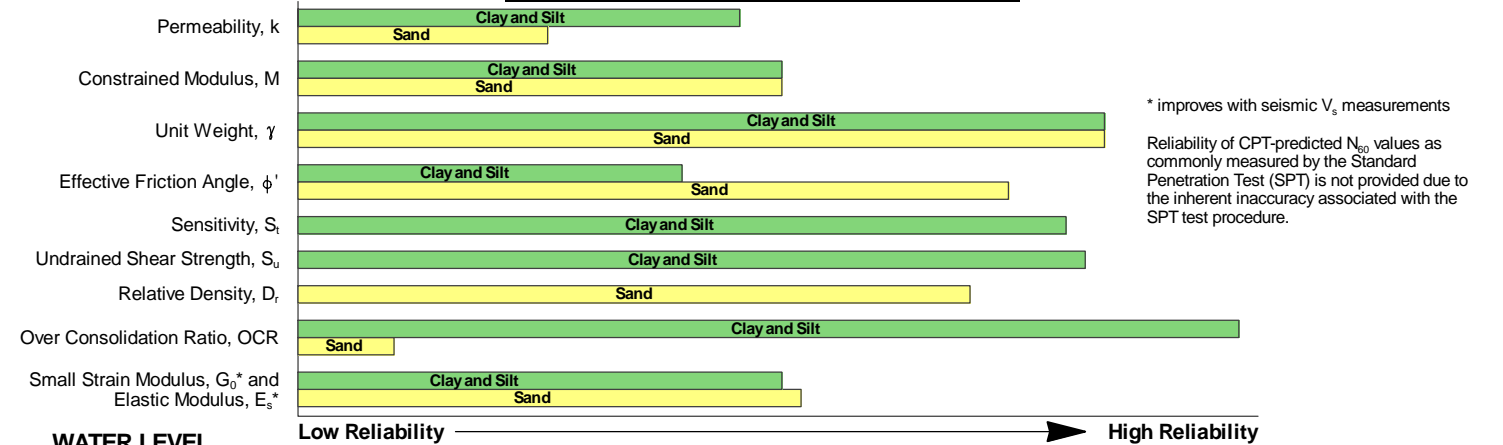

WATER LEVEL

The groundwater level at the CPT location is used to normalize the measurements for vertical overburden pressures and as a result influences the normalized soil behavior type classification and correlated soil parameters. The water level may either be "measured" or "estimated."

Measured - Depth to water directly measured in the field

Estimated - Depth to water interpolated by the practitioner using pore pressure measurements in coarse grained soils and known site conditions

While groundwater levels displayed as "measured" more accurately represent site conditions at the time of testing than those "estimated," in either case the groundwater should be further defined prior to construction as groundwater level variations will occur over time.

CONE PENETRATION SOIL BEHAVIOR TYPE

The estimated stratigraphic profiles included in the CPT logs are based on relationships between corrected tip resistance (q_t), friction resistance (f_s), and porewater pressure (u_2). The normalized friction ratio (F_r) is used to classify the soil behavior type.

Typically, silts and clays have high F_r values and generate large excess penetration porewater pressures; sands have lower F_r 's and do not generate excess penetration porewater pressures. The adjacent graph (Robertson *et al.*) presents the soil behavior type correlation used for the logs. This normalized SBT chart, generally considered the most reliable, does not use pore pressure to determine SBT due to its lack of repeatability in onshore CPTs.

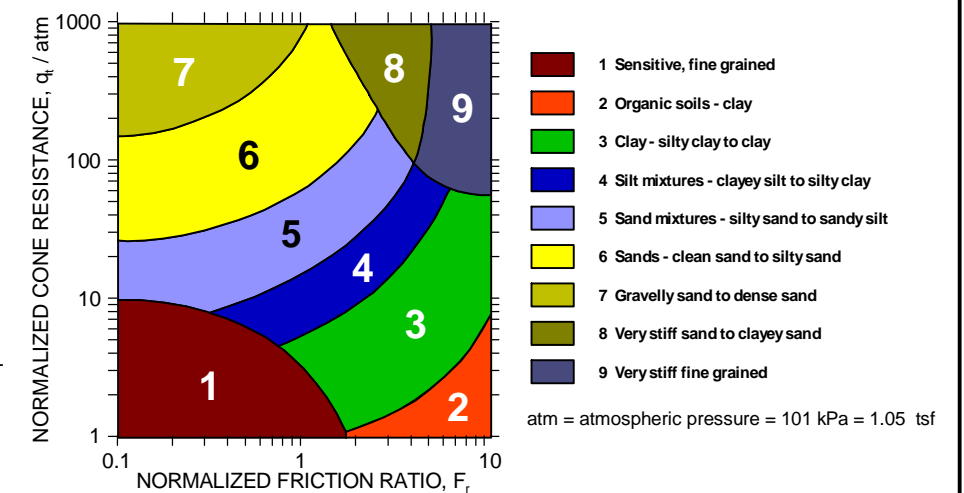

REFERENCES

Kulhawy, F.H., Mayne, P.W., (1997). "Manual on Estimating Soil Properties for Foundation Design," Electric Power Research Institute, Palo Alto, CA.
 Mayne, P.W., (2013). "Geotechnical Site Exploration in the Year 2013," Georgia Institute of Technology, Atlanta, GA.
 Robertson, P.K., Cabal, K.L. (2012). "Guide to Cone Penetration Testing for Geotechnical Engineering," Signal Hill, CA.
 Schmertmann, J.H., (1970). "Static Cone to Compute Static Settlement over Sand," *Journal of the Soil Mechanics and Foundations Division*, 96(SM3), 1011-1043.

CPT LOG NO. Y2-EB2-CPT-1

CLIENT: NCDOT Geotechnical Engineering Unit
Raleigh, NC

PROJECT: I-5987A - I-95 Mile 21 to 29

SITE: I-95
Robeson County, NC

TEST LOCATION:

Northing: 345984
Easting: 2000659

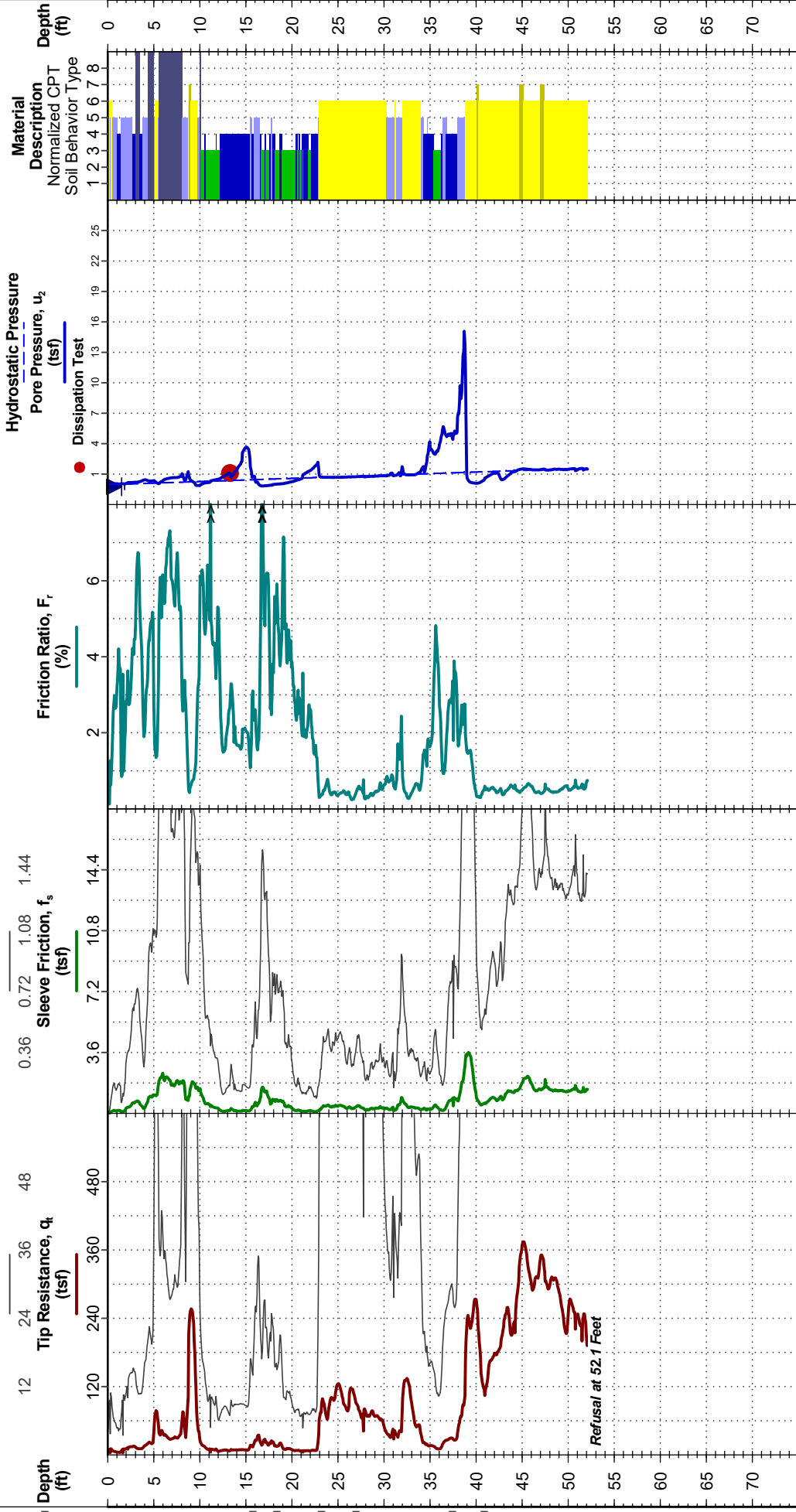

Auger anchors used as reaction force.
CPT sensor calibration reports available upon request.



Probe no. 5311 with net area ratio of .874
U2 pore pressure transducer location
Manufactured by Geotech A.B.; calibrated 1/7/2020
Tip and sleeve areas of 10 cm² and 150 cm²
Ring friction reducer with O.D. of 1.875 in

WATER LEVEL OBSERVATION
1.5 ft measured water depth
(used in normalizations and correlations)

CPT Started: 2/23/2021
Rig: Geoprobe 477
Project No.: 47533.1.1

CPT Completed: 2/23/2021

Operator: BR

CPT LOG NO. Y2-EB1-CPT-2

CLIENT: NCDOT Geotechnical Engineering Unit
Raleigh, NC

PROJECT: I-5987A - I-95 Mile 21 to 29

SITE: I-95
Robeson County, NC

TEST LOCATION:

Northing: 345962
Easting: 2000405

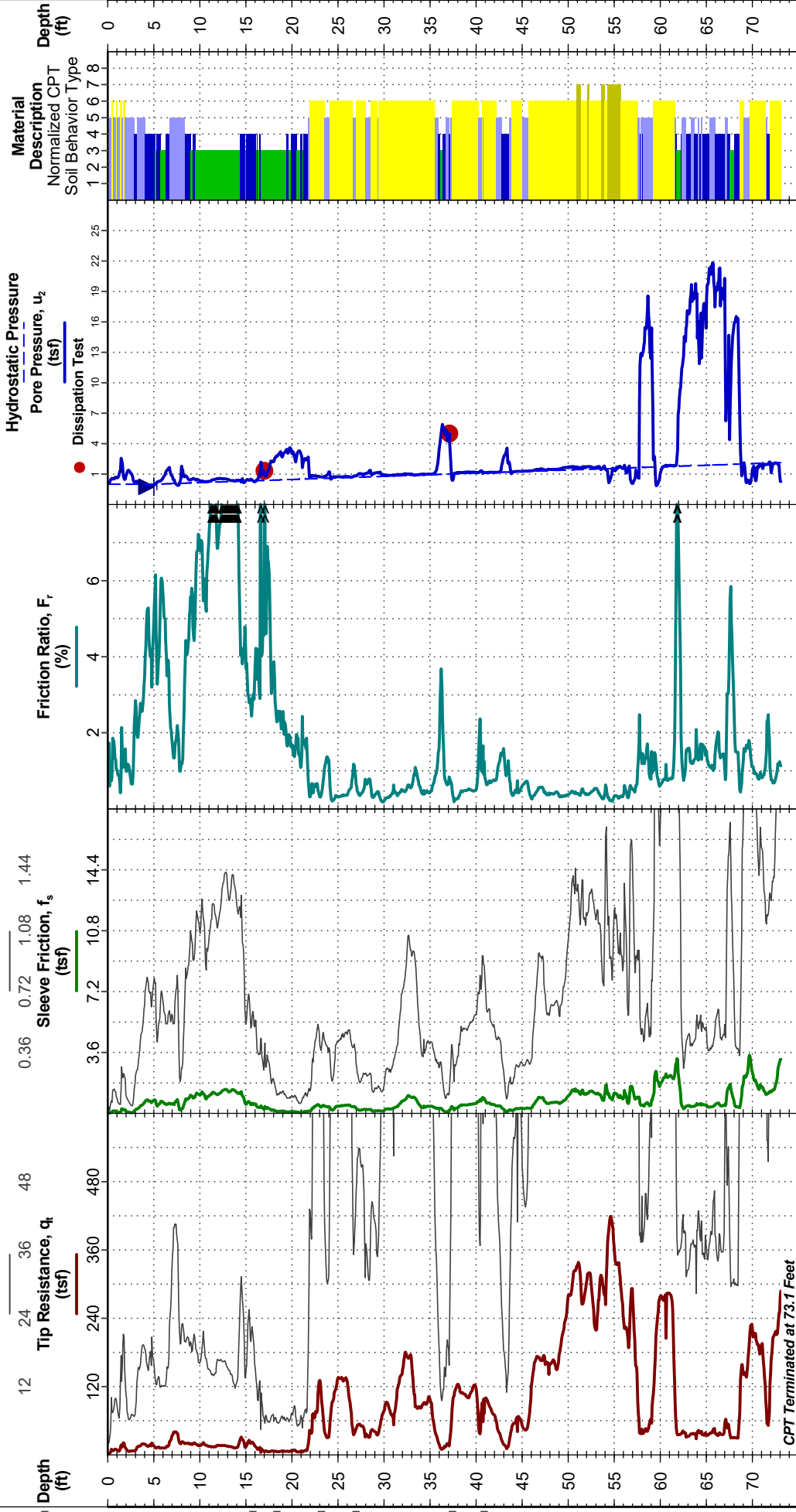

Auger anchors used as reaction force.
CPT sensor calibration reports available upon request.



Probe no. 5311 with net area ratio of .874
U2 pore pressure transducer location
Manufactured by Geotech A.B.; calibrated 1/7/2020
Tip and sleeve areas of 10 cm² and 150 cm²
Ring friction reducer with O.D. of 1.875 in

WATER LEVEL OBSERVATION
5 ft measured water depth
(used in normalizations and correlations)

CPT Started: 2/26/2021
Rig: Geoprobe 477
Project No.: 47533.1.1

CPT Completed: 2/26/2021

Operator: BR

CPT LOG NO. Y1AARPBCPT3

PROJECT: I-5987A - I-95 Mile 21 to 29

TEST LOCATION:

SITE: I-95
Robeson County, NC

Northing: 352971
Easting: 2000577

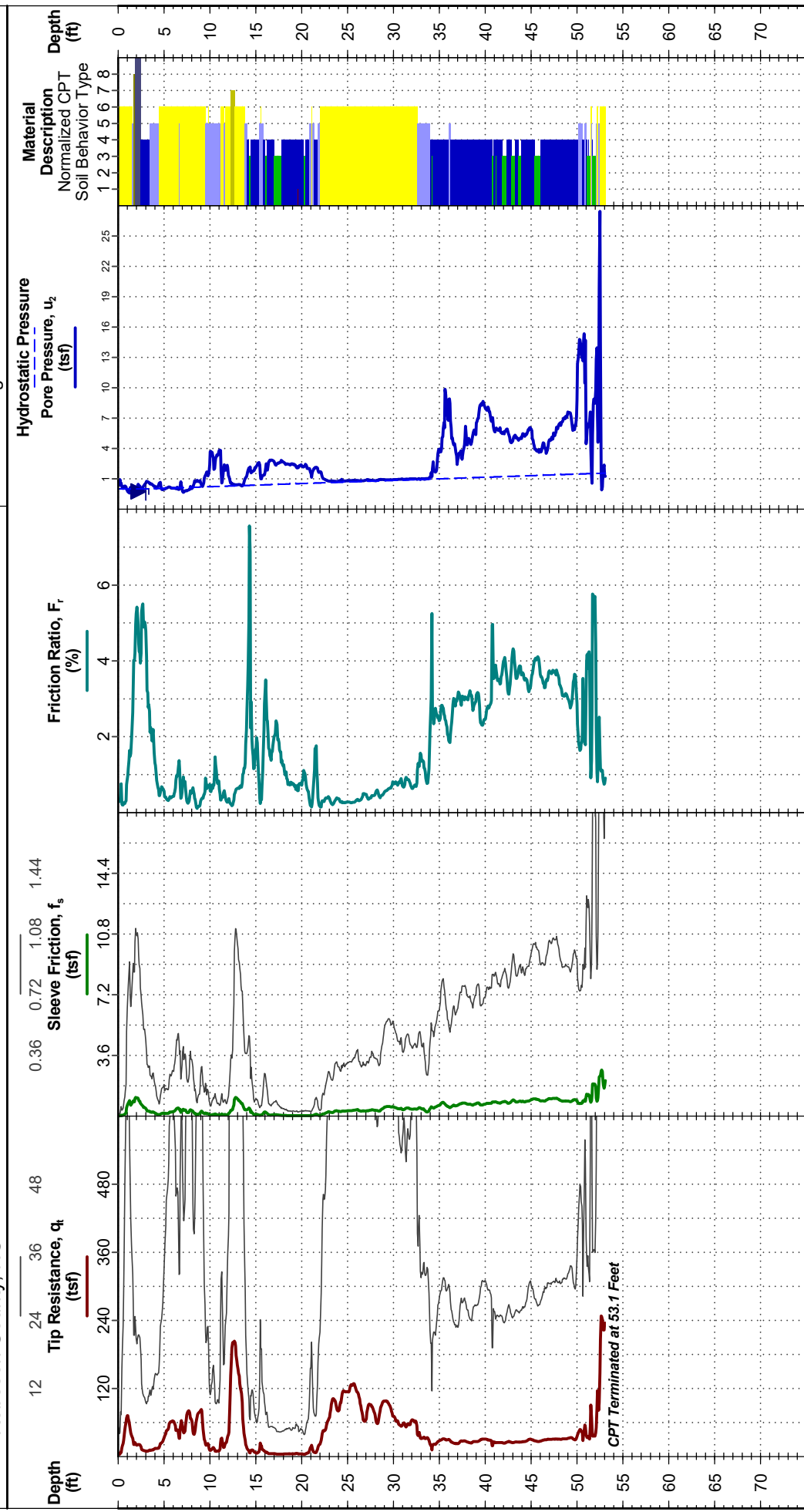

Auger anchors used as reaction force.
CPT sensor calibration reports available upon request.



Probe no. 5311 with net area ratio of .874
U2 pore pressure transducer location
Manufactured by Geotech A.B.; calibrated 1/7/2020
Tip and sleeve areas of 10 cm² and 150 cm²
Ring friction reducer with O.D. of 1.875 in

WATER LEVEL OBSERVATION
3 ft measured water depth
(used in normalizations and correlations)

CPT Started: 2/25/2021
Rig: Geoprobe 477
Project No.: 47533.1.1
CPT Completed: 2/25/2021
Operator: BR

CPT LOG NO. Y1A-CPT-4

PROJECT: I-5987A - I-95 Mile 21 to 29

TEST LOCATION:

SITE: I-95
Robeson County, NC

Northing: 353320
Easting: 2000251

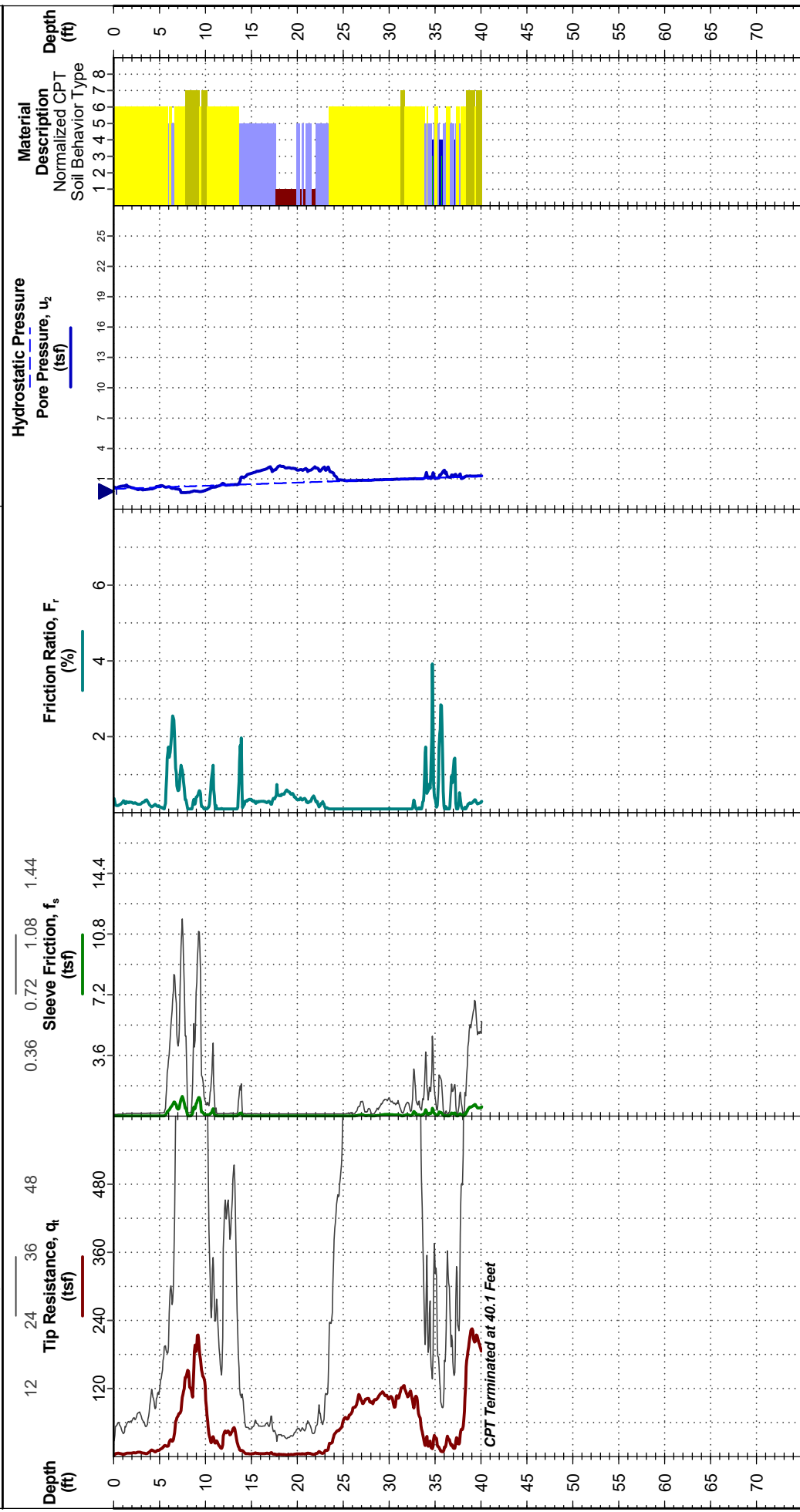

Auger anchors used as reaction force.
CPT sensor calibration reports available upon request.



Probe no. 5311 with net area ratio of .874
U2 pore pressure transducer location
Manufactured by Geotech A.B.; calibrated 1/7/2020
Tip and sleeve areas of 10 cm² and 150 cm²
Ring friction reducer with O.D. of 1.875 in

WATER LEVEL OBSERVATION
0 ft measured water depth
(used in normalizations and correlations)

CPT Started: 2/25/2021
Rig: Geoprobe 477
Project No.: 47533.1.1
CPT Completed: 2/25/2021
Operator: BR

CPT LOG NO. Y1A-EB1-CPT5

PROJECT: I-5987A - I-95 Mile 21 to 29
SITE: I-95
 Robeson County, NC

TEST LOCATION:

Northing: 353320
 Easting: 2000251

CLIENT: NCDOT Geotechnical Engineering Unit
 Raleigh, NC

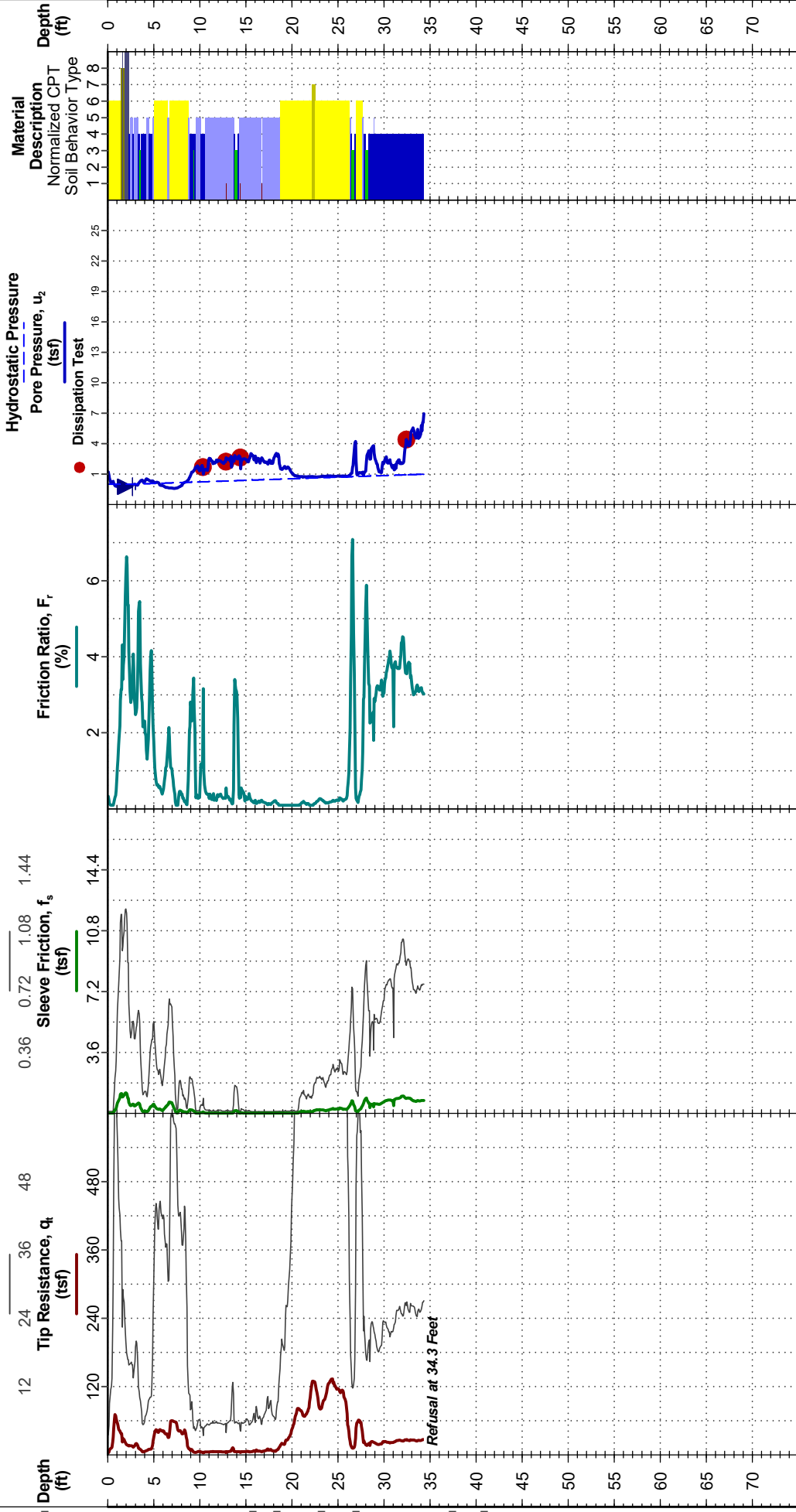

Auger anchors used as reaction force.
 CPT sensor calibration reports available upon request.



Probe no. 5311 with net area ratio of .874
 U2 pore pressure transducer location
 Manufactured by Geotech A.B.; calibrated 1/7/2020
 Tip and sleeve areas of 10 cm² and 150 cm²
 Ring friction reducer with O.D. of 1.875 in

WATER LEVEL OBSERVATION
 2.7 ft measured water depth
 (used in normalizations and correlations)

CPT Started: 2/24/2021
 Rig: Geoprobe 477
 Project No.: 47533.1.1
 CPT Completed: 2/24/2021
 Operator: BR

CPT LOG NO. Y1A-EB1CPT5A

PROJECT: I-5987A - I-95 Mile 21 to 29
SITE: I-95
 Robeson County, NC

TEST LOCATION:

Northing: 353620
 Easting: 2000691

CLIENT: NCDOT Geotechnical Engineering Unit
 Raleigh, NC

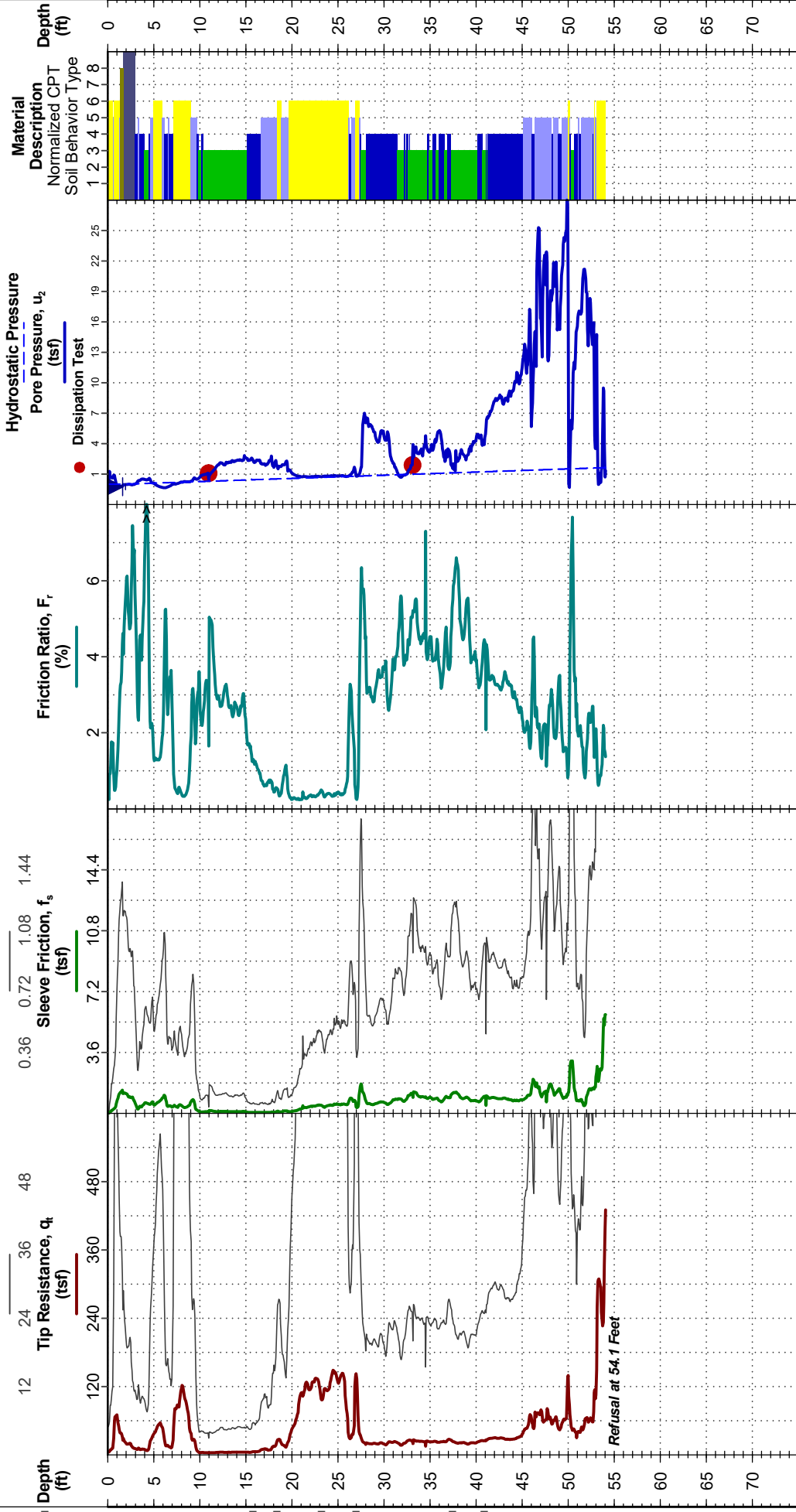

Auger anchors used as reaction force.
 CPT sensor calibration reports available upon request.



Probe no. 5311 with net area ratio of .874
 U2 pore pressure transducer location
 Manufactured by Geotech A.B.; calibrated 1/7/2020
 Tip and sleeve areas of 10 cm² and 150 cm²
 Ring friction reducer with O.D. of 1.875 in

WATER LEVEL OBSERVATION
 1.6 ft measured water depth
 (used in normalizations and correlations)

CPT Started: 2/25/2021
 Rig: Geoprobe 477
 Project No.: 47533.1.1
 CPT Completed: 2/25/2021
 Operator: BR

CPT LOG NO. Y1A-EB2-CPT6

PROJECT: I-5987A - I-95 Mile 21 to 29

SITE: I-95
Robeson County, NC

TEST LOCATION:

Northing: 353599
Easting: 2000887

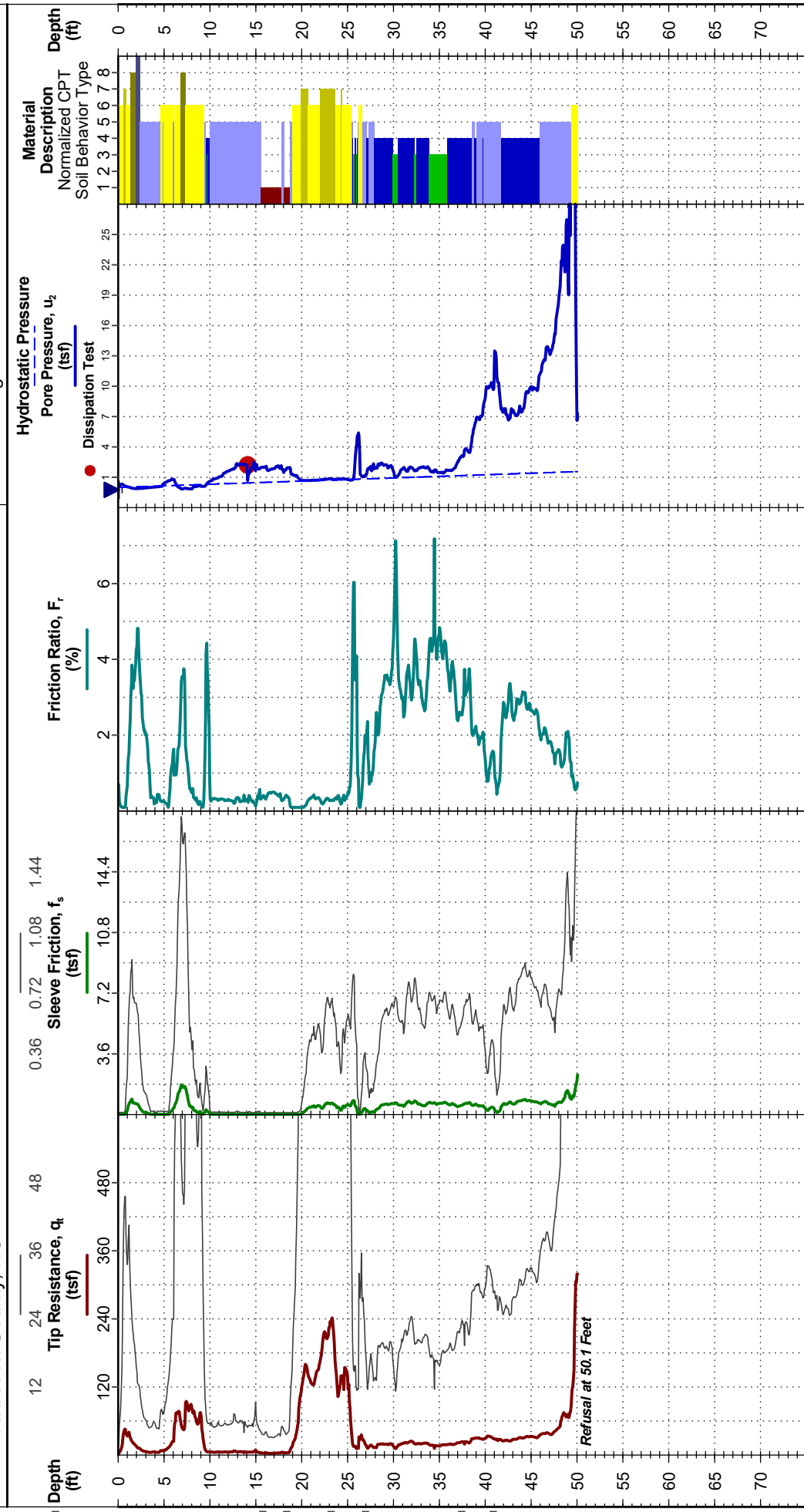

Auger anchors used as reaction force.
CPT sensor calibration reports available upon request.



Probe no. 5311 with net area ratio of .874
U2 pore pressure transducer location
Manufactured by Geotech A.B.; calibrated 1/7/2020
Tip and sleeve areas of 10 cm² and 150 cm²
Ring friction reducer with O.D. of 1.875 in

WATER LEVEL OBSERVATION
0.1 ft measured water depth
(used in normalizations and correlations)

CPT Started: 2/23/2021
Rig: Geoprobe 477
Project No.: 47533.1.1
CPT Completed: 2/23/2021
Operator: BR

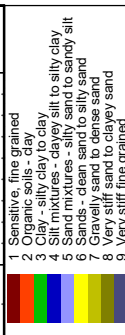

CPT LOG NO. C3-CPT-7

PROJECT: I-5987A - I-95 Mile 21 to 29

SITE: I-95
Robeson County, NC

TEST LOCATION:

Northing: 356105
Easting: 2000724

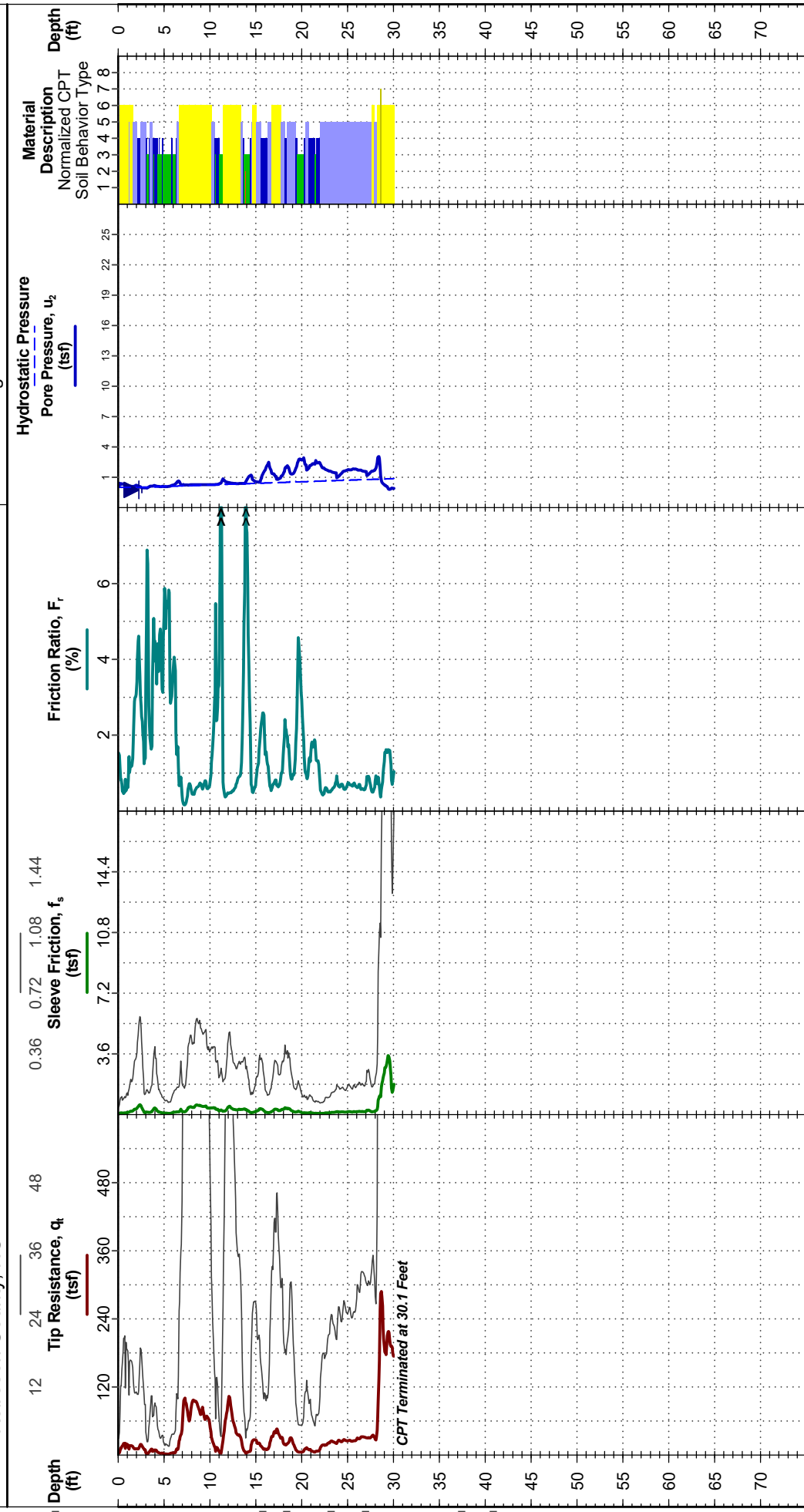

Auger anchors used as reaction force.
CPT sensor calibration reports available upon request.



Probe no. 5311 with net area ratio of .874
U2 pore pressure transducer location
Manufactured by Geotech A.B.; calibrated 1/7/2020
Tip and sleeve areas of 10 cm² and 150 cm²
Ring friction reducer with O.D. of 1.875 in

WATER LEVEL OBSERVATION
2.25 ft measured water depth
(used in normalizations and correlations)

CPT Started: 2/24/2021
Rig: Geoprobe 477
Project No.: 47533.1.1
CPT Completed: 2/24/2021
Operator: BR

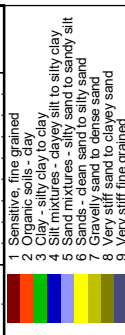

CPT LOG NO. C3-CPT8

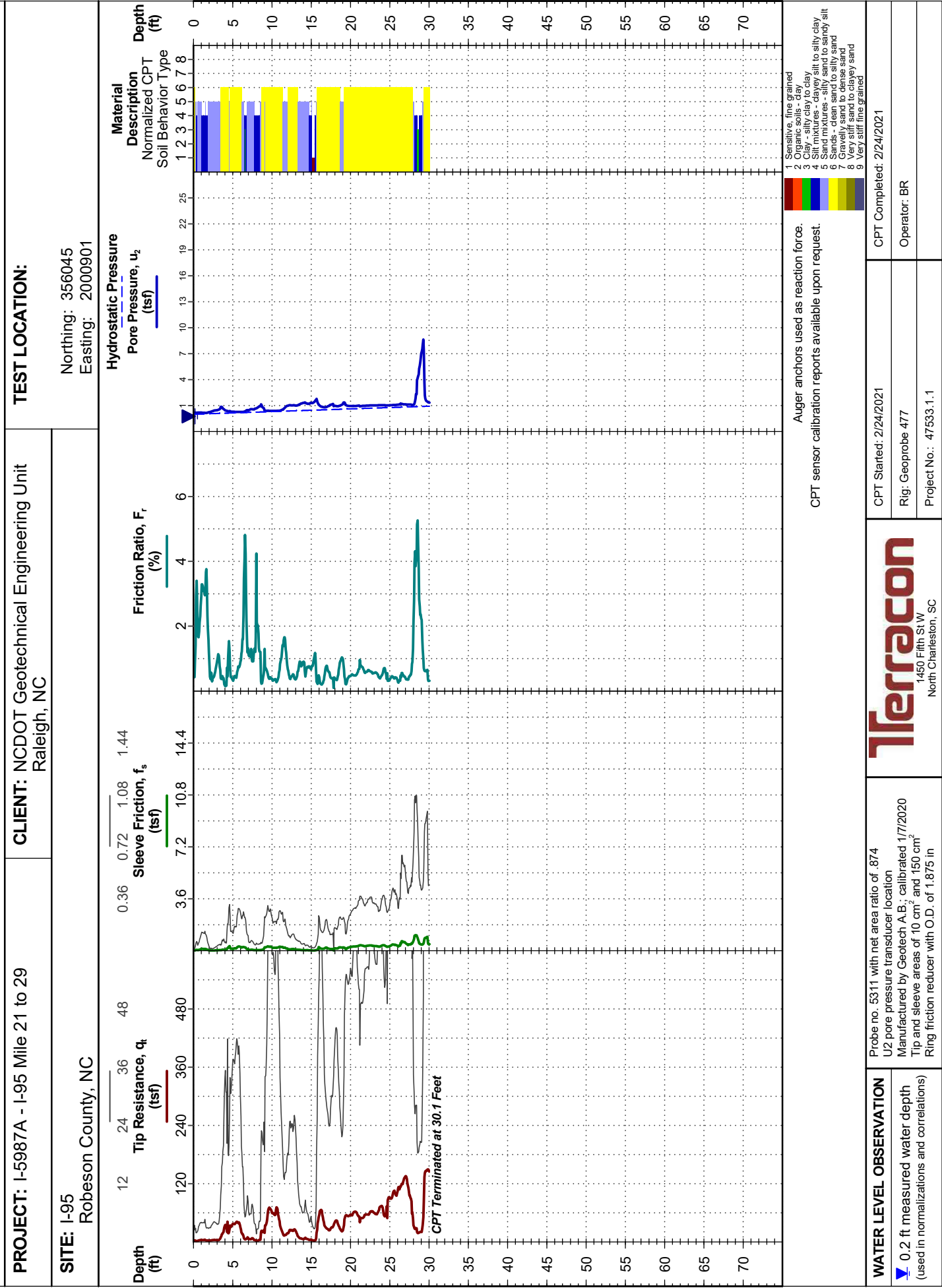

THIS BORING LOG IS NOT VALID IF SEPARATED FROM ORIGINAL REPORT. NCDOT_CPT_REPORT_15987_GEO_RDWY_BH_TERRACON_CPT.GPJ TERRACON DATETEMPLATE.GDT 6/30/21

CPT LOG NO. C4-CPT-9

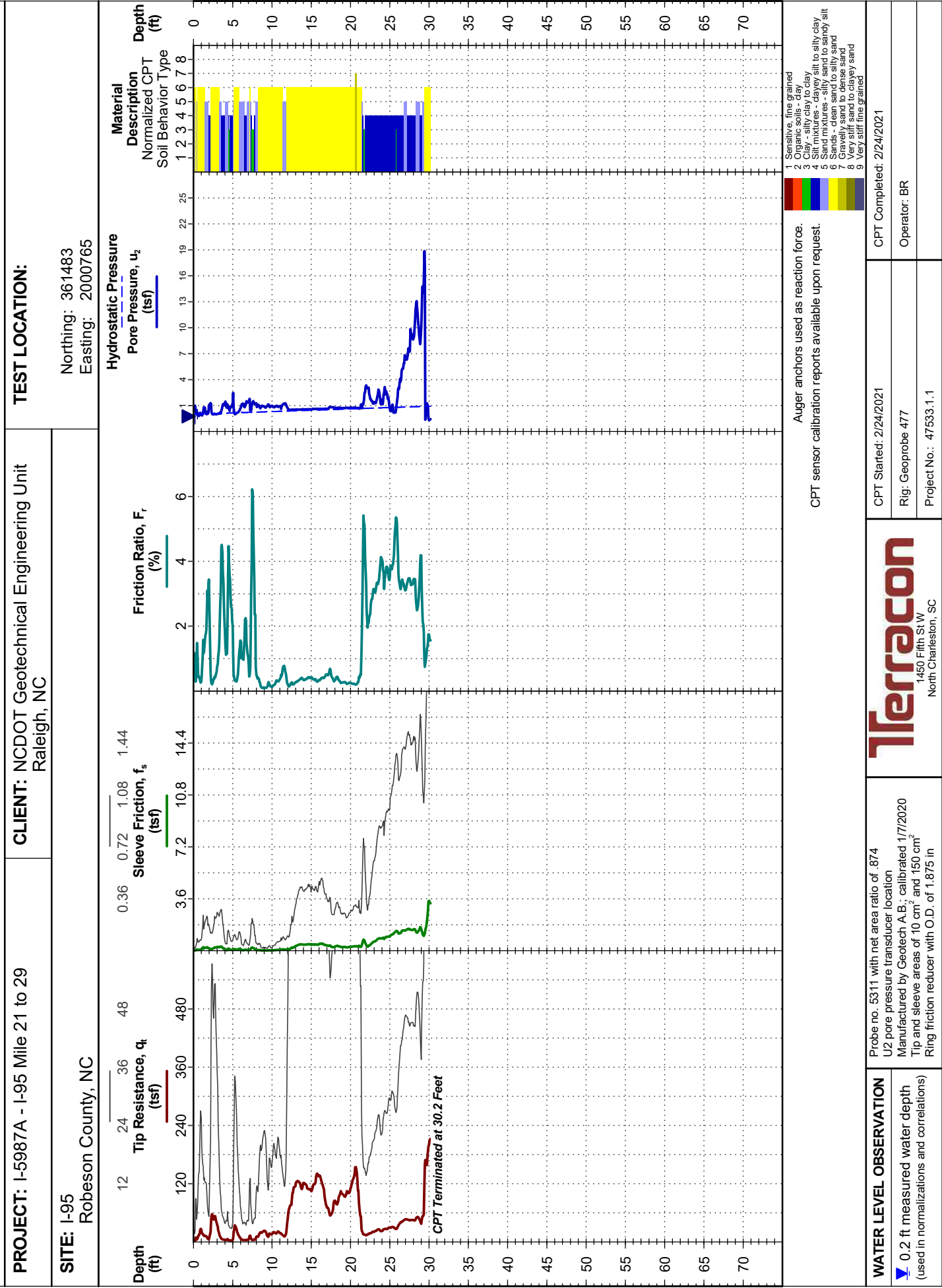

THIS BORING LOG IS NOT VALID IF SEPARATED FROM ORIGINAL REPORT. NCDOT_CPT_REPORT_15987_GEO_RDWY_BH_TERRACON_CPT.GPJ TERRACON DATETEMPLATE.GDT 6/30/21

Auger anchors used as reaction force.
CPT sensor calibration reports available upon request.

Auger anchors used as reaction force.
CPT sensor calibration reports available upon request.

- 1 Sensitive, fine grained
- 2 Organic soils - clay
- 3 Silty clay
- 4 Silt mixtures - clayey silt to silty clay
- 5 Sand mixtures - silty sand to sandy silt
- 6 Sands - clean sand to silty sand
- 7 Gravely sand to dense sand
- 8 Very dense sand to gravelly sand
- 9 Very stiff, fine grained

- 1 Sensitive, fine grained
- 2 Organic soils - clay
- 3 Silty clay
- 4 Silt mixtures - clayey silt to silty clay
- 5 Sand mixtures - silty sand to sandy silt
- 6 Sands - clean sand to silty sand
- 7 Gravely sand to dense sand
- 8 Very dense sand to gravelly sand
- 9 Very stiff, fine grained

CPT LOG NO. Y3-EB1-CPT10

CLIENT: NCDOT Geotechnical Engineering Unit
Raleigh, NC

PROJECT: I-5987A - I-95 Mile 21 to 29

SITE: I-95
Robeson County, NC

TEST LOCATION:

Northing: 371162
Easting: 2001014

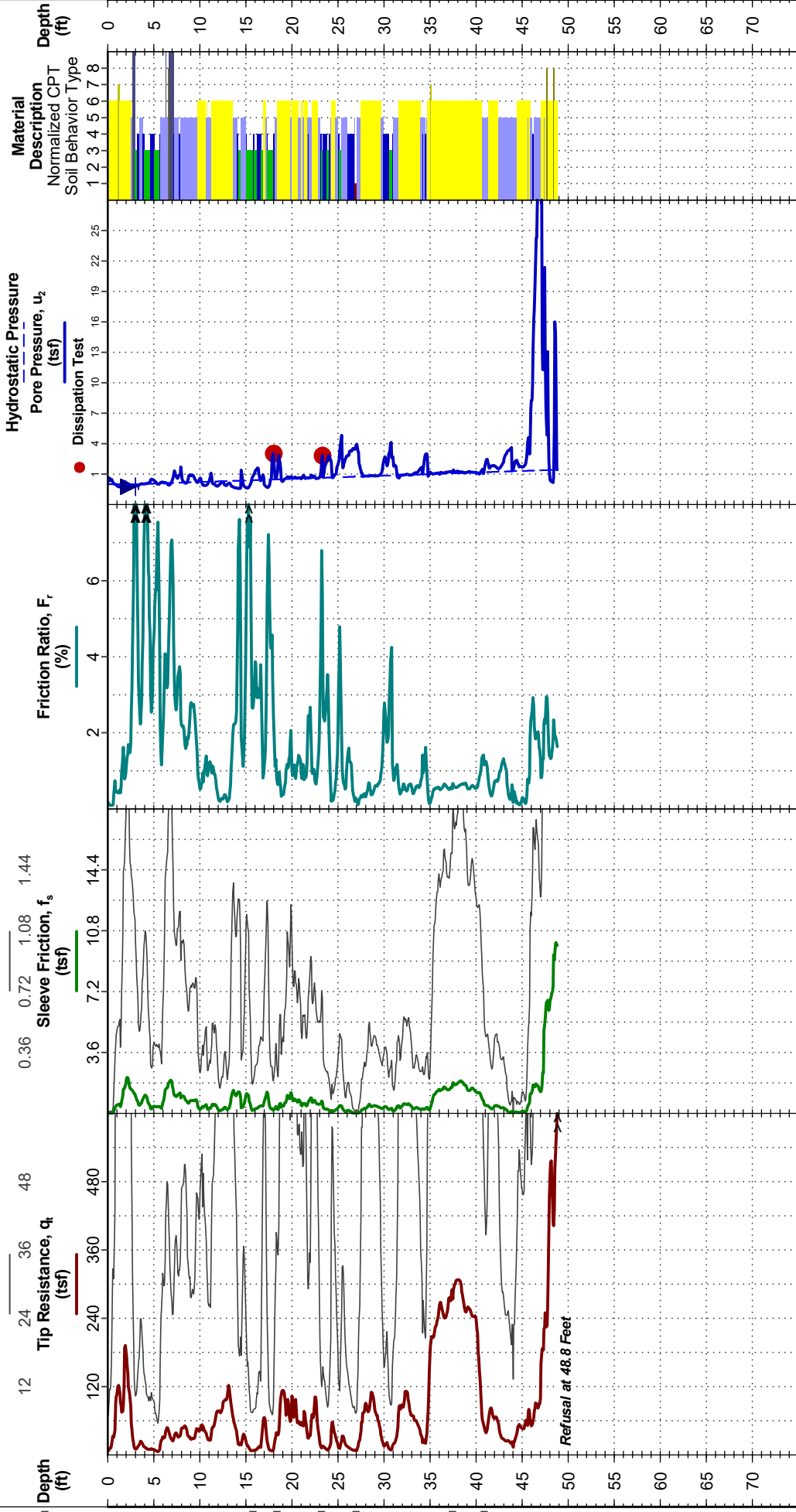

Auger anchors used as reaction force.
CPT sensor calibration reports available upon request.



Probe no. 5311 with net area ratio of .874
U2 pore pressure transducer location
Manufactured by Geotech A.B.; calibrated 1/7/2020
Tip and sleeve areas of 10 cm² and 150 cm²
Ring friction reducer with O.D. of 1.875 in

WATER LEVEL OBSERVATION
3 ft measured water depth
(used in normalizations and correlations)

CPT Started: 2/24/2021
Rig: Geoprobe 477
Project No.: 47533.1.1
CPT Completed: 2/24/2021
Operator: BR

CPT LOG NO. Y3-EB2-CPT11

CLIENT: NCDOT Geotechnical Engineering Unit
Raleigh, NC

PROJECT: I-5987A - I-95 Mile 21 to 29

SITE: I-95
Robeson County, NC

TEST LOCATION:

Northing: 371427
Easting: 2001255

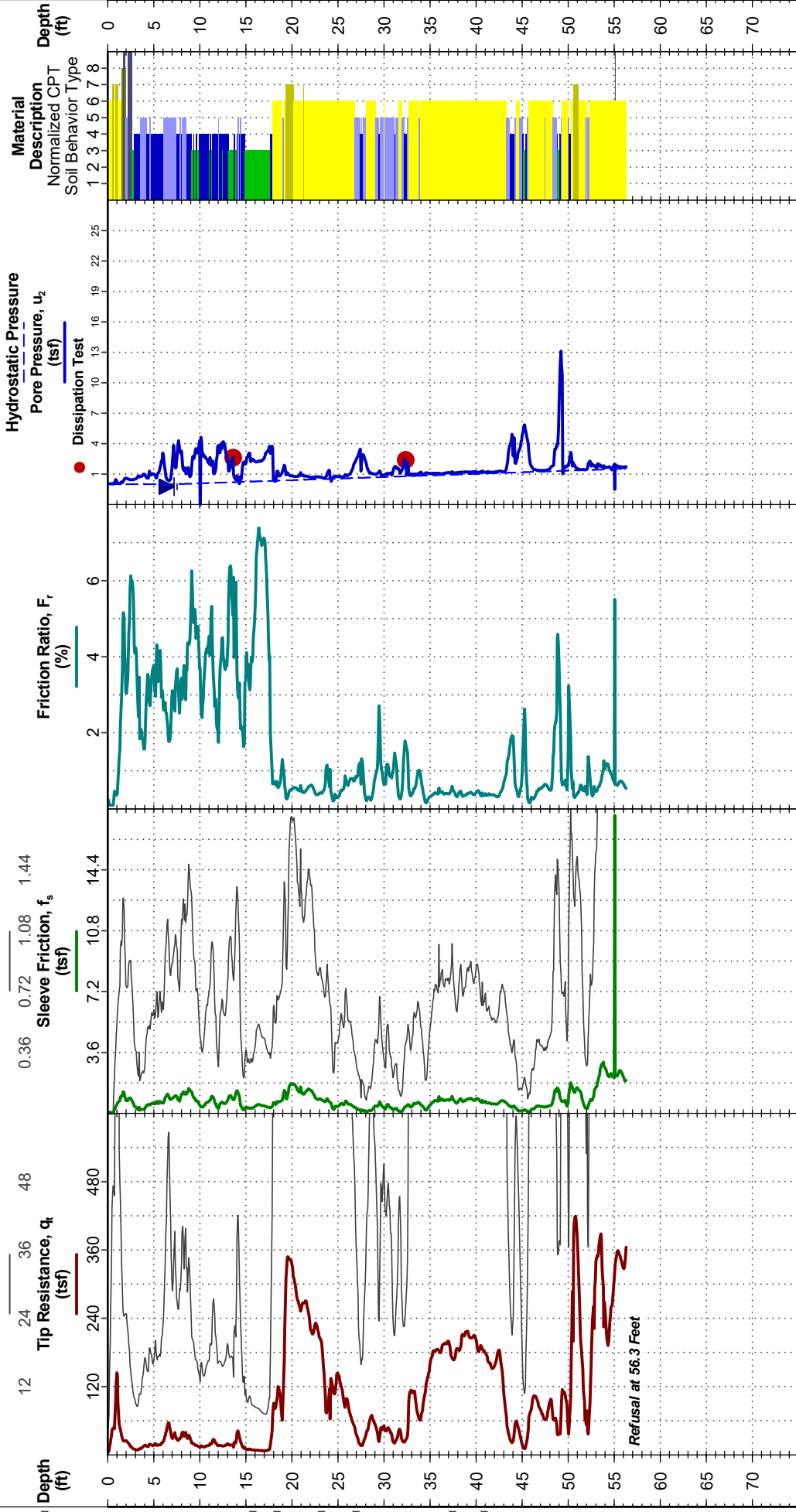

Auger anchors used as reaction force.
CPT sensor calibration reports available upon request.



Probe no. 5311 with net area ratio of .874
U2 pore pressure transducer location
Manufactured by Geotech A.B.; calibrated 1/7/2020
Tip and sleeve areas of 10 cm² and 150 cm²
Ring friction reducer with O.D. of 1.875 in

WATER LEVEL OBSERVATION
7.2 ft measured water depth
(used in normalizations and correlations)

CPT Started: 2/24/2021
Rig: Geoprobe 477
Project No.: 47533.1.1
CPT Completed: 2/24/2021
Operator: BR

CONE PENETROMETER TEST BORING REPORT



WBS: 47533.1.1	TIP: I-5987A	COUNTY: ROBESON/CUMBERLAND	GEOLOGIST: S. HUDSON
SITE DESCRIPTION: I-95 CUMBERLAND/ROBESON COUNTIES FROM US 301 (EXIT 22) TO I-95 BUSINESS/US 301 (EXIT 40)			GROUND WTR (ft)
BORING NO.: L_11200_LT	STATION: 112+00	OFFSET: 90 ft LT	ALIGNMENT: -L-
COLLAR ELEV.: 126.8 ft	TOTAL DEPTH: 9.4 ft	NORTHING: 336,372	EASTING: 1,998,515
CPT RIG/MAX. DOWN PRESSURE: CATLIN CPT/DPT-01 / 9 TONS (NO ANCHORS)		CONE TYPE: TYPE 2 PIEZOCONE	CONE ID: DSG0867
DRILLER: EDDIE SWAIN	OPERATOR: CATLIN	START DATE: 02/04/20	COMP. DATE: 02/04/20
		SURF. WATER DEPTH: N/A	

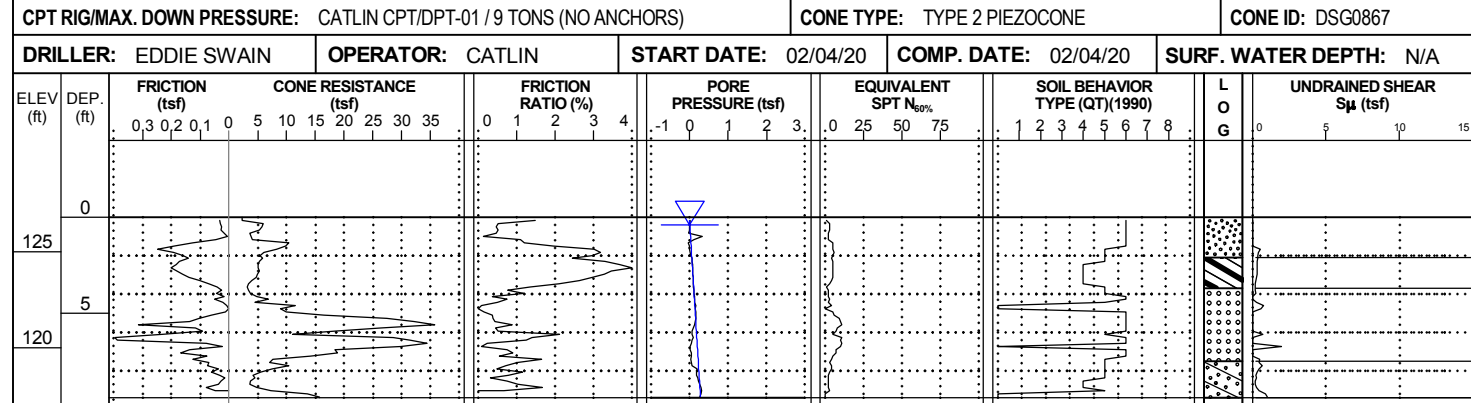

(0 HR. GROUNDWATER ESTIMATED FROM PORE PRESSURE)
Boring Terminated at Elevation 117.4 ft

WBS: 47533.1.1	TIP: I-5987A	COUNTY: ROBESON/CUMBERLAND	GEOLOGIST: S. HUDSON
SITE DESCRIPTION: I-95 CUMBERLAND/ROBESON COUNTIES FROM US 301 (EXIT 22) TO I-95 BUSINESS/US 301 (EXIT 40)			GROUND WTR (ft)
BORING NO.: L_11700_LT	STATION: 117+00	OFFSET: 100 ft LT	ALIGNMENT: -L-
COLLAR ELEV.: 128.2 ft	TOTAL DEPTH: 9.4 ft	NORTHING: 336,857	EASTING: 1,998,636
CPT RIG/MAX. DOWN PRESSURE: CATLIN CPT/DPT-01 / 9 TONS (NO ANCHORS)		CONE TYPE: TYPE 2 PIEZOCONE	CONE ID: DSG0867
DRILLER: EDDIE SWAIN	OPERATOR: CATLIN	START DATE: 02/04/20	COMP. DATE: 02/04/20
		SURF. WATER DEPTH: N/A	

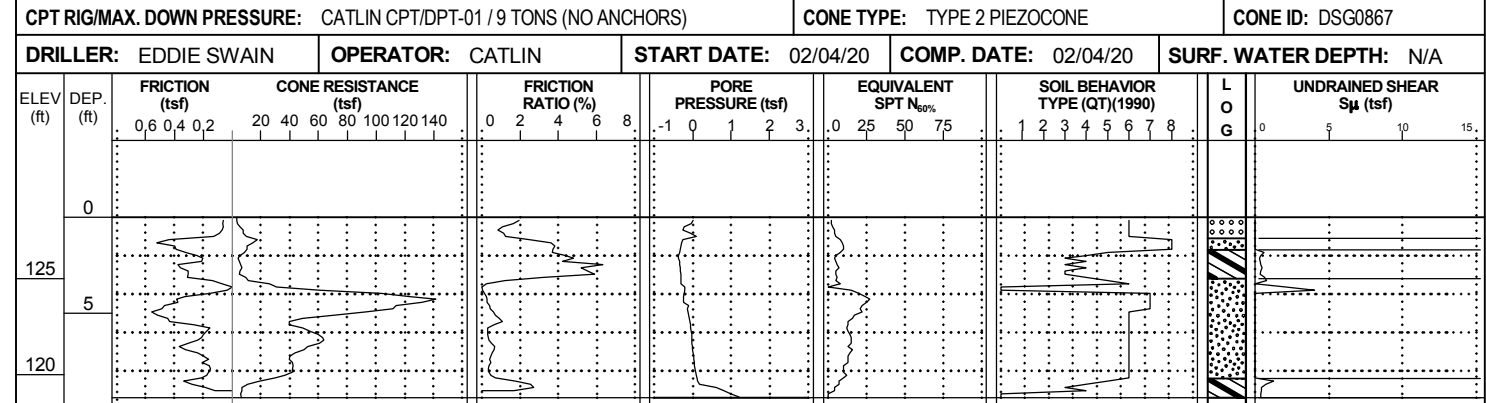

(0 HR. GROUNDWATER ESTIMATED FROM PORE PRESSURE)
Boring Terminated at Elevation 118.8 ft
PORE PRESSURE NOT CONDUSIVE TO ESTIMATING GROUND WATER - EST. GROUNDWATER SUSPECT

NCDOI CPT DOUBLE (PORTRAIT) NO-LITH 15987_GEO_RDWY_CATLIN_GTM-DRILLED_REVISED.GPJ_NCDOT_CATLIN.GDT_07/30/20

CONE PENETROMETER TEST BORING REPORT



WBS: 47533.1.1	TIP: I-5987A	COUNTY: ROBESON/CUMBERLAND	GEOLOGIST: S. HUDSON
SITE DESCRIPTION: I-95 CUMBERLAND/ROBESON COUNTIES FROM US 301 (EXIT 22) TO I-95 BUSINESS/US 301 (EXIT 40)			GROUND WTR (ft)
BORING NO.: L_12200_LT	STATION: 122+00	OFFSET: 105 ft LT	ALIGNMENT: -L-
COLLAR ELEV.: 131.4 ft	TOTAL DEPTH: 9.5 ft	NORTHING: 337,341	EASTING: 1,998,763
CPT RIG/MAX. DOWN PRESSURE: CATLIN CPT/DPT-01 / 9 TONS (NO ANCHORS)		CONE TYPE: TYPE 2 PIEZOCONE	CONE ID: DSG0867
DRILLER: EDDIE SWAIN	OPERATOR: CATLIN	START DATE: 02/04/20	COMP. DATE: 02/04/20
EST. 0 HR. 1.3		24 HR. N/A	

WBS: 47533.1.1	TIP: I-5987A	COUNTY: ROBESON/CUMBERLAND	GEOLOGIST: S. HUDSON
SITE DESCRIPTION: I-95 CUMBERLAND/ROBESON COUNTIES FROM US 301 (EXIT 22) TO I-95 BUSINESS/US 301 (EXIT 40)			GROUND WTR (ft)
BORING NO.: L_12700_LT	STATION: 127+00	OFFSET: 103 ft LT	ALIGNMENT: -L-
COLLAR ELEV.: 133.6 ft	TOTAL DEPTH: 12.5 ft	NORTHING: 337,823	EASTING: 1,998,896
CPT RIG/MAX. DOWN PRESSURE: CATLIN CPT/DPT-01 / 9 TONS (NO ANCHORS)		CONE TYPE: TYPE 2 PIEZOCONE	CONE ID: DSG0867
DRILLER: EDDIE SWAIN	OPERATOR: CATLIN	START DATE: 02/04/20	COMP. DATE: 02/04/20
EST. 0 HR. 1.8		24 HR. N/A	

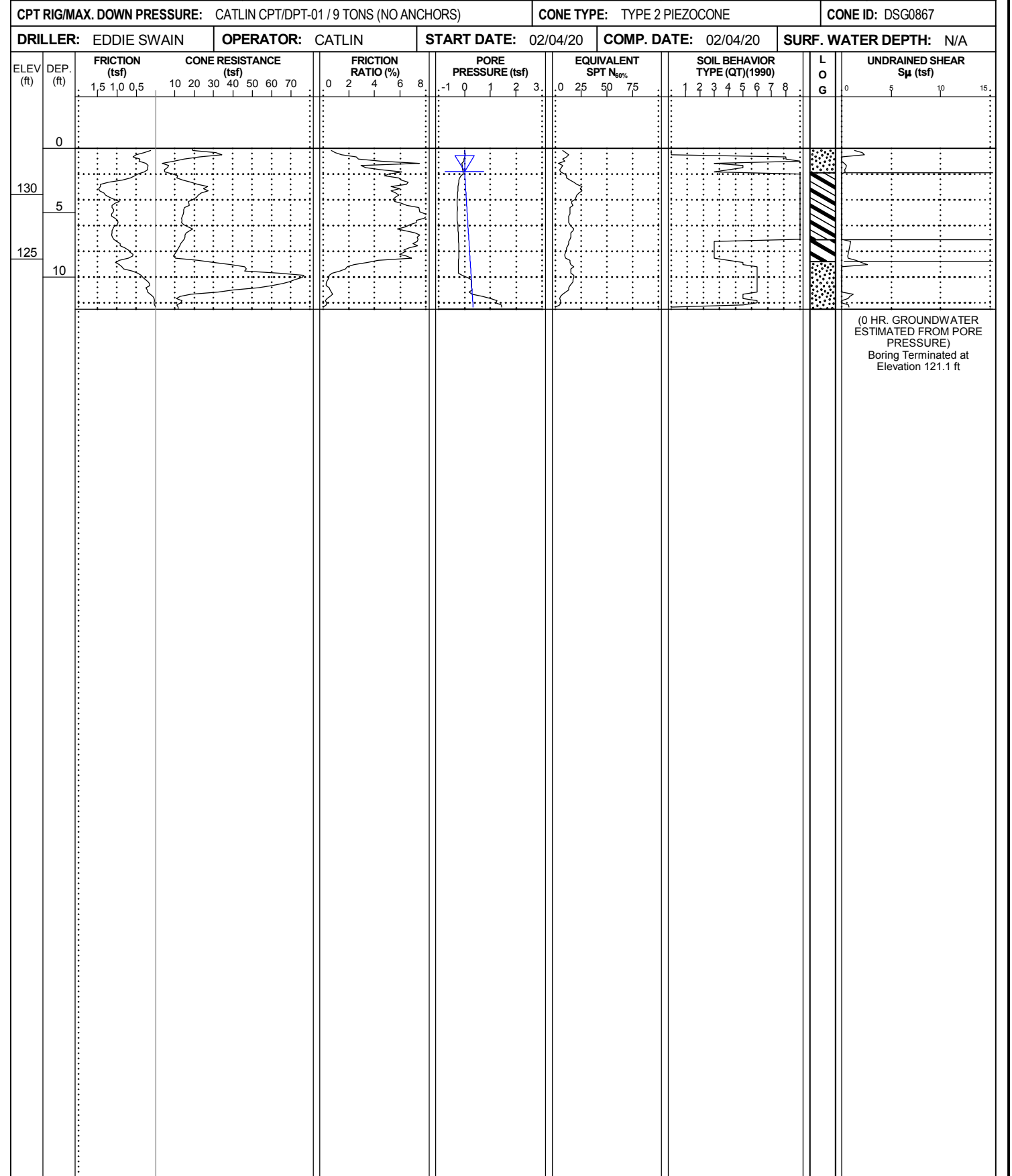
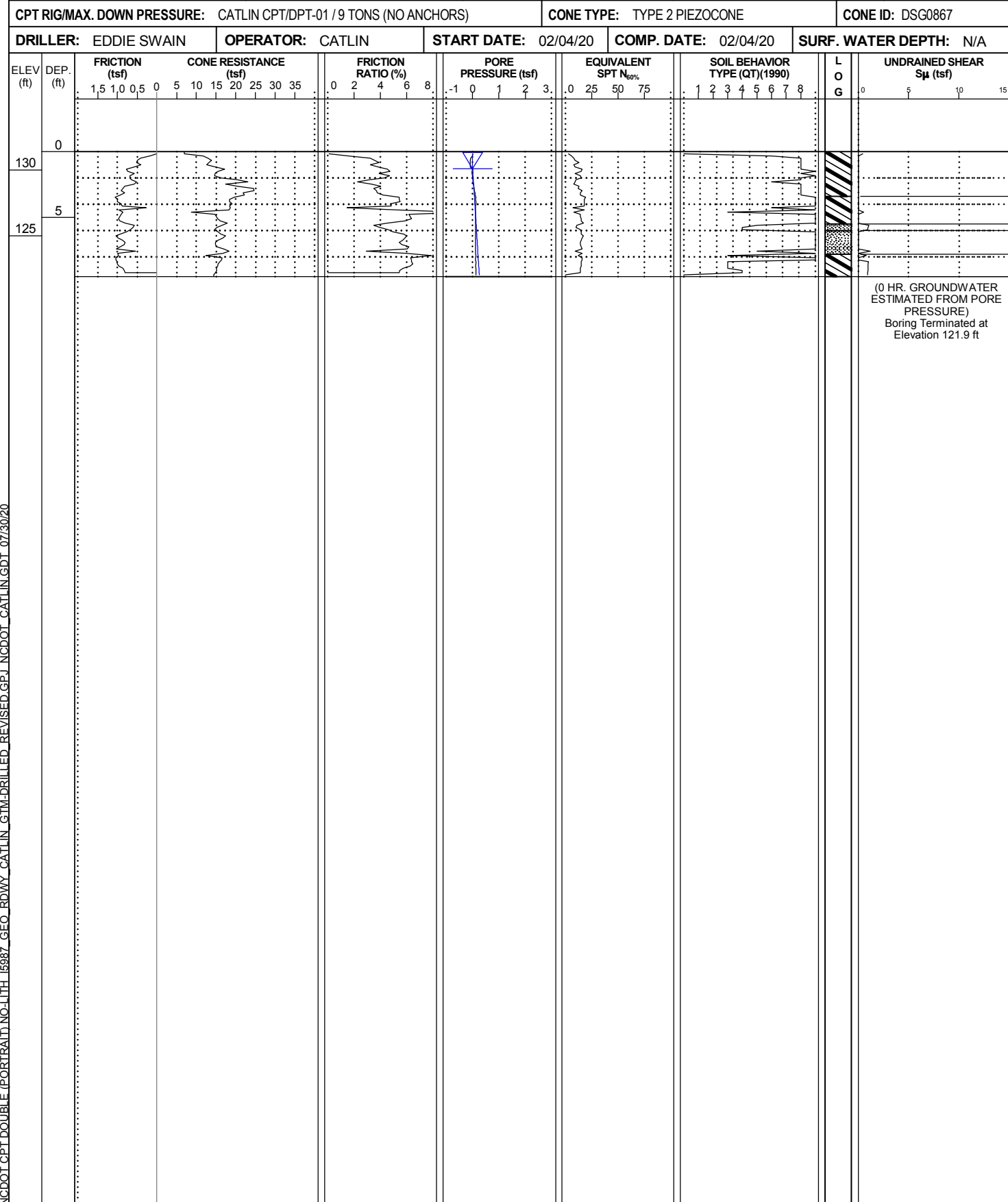

NCDOT CPT DOUBLE (PORTRAIT) NO-LITH I5987_GEO_RDWY_CATLIN_GTM-DRILLED_REVISED.GPJ NCDOT_CATLIN.GDT 07/30/20

CONE PENETROMETER TEST BORING REPORT



WBS: 47533.1.1	TIP: I-5987A	COUNTY: ROBESON/CUMBERLAND	GEOLOGIST: S. HUDSON
SITE DESCRIPTION: I-95 CUMBERLAND/ROBESON COUNTIES FROM US 301 (EXIT 22) TO I-95 BUSINESS/US 301 (EXIT 40)			GROUND WTR (ft)
BORING NO.: L_13200_LT	STATION: 132+00	OFFSET: 105 ft LT	ALIGNMENT: -L-
COLLAR ELEV.: 134.1 ft	TOTAL DEPTH: 12.5 ft	NORTHING: 338,306	EASTING: 1,999,025
CPT RIG/MAX. DOWN PRESSURE: CATLIN CPT/DPT-01 / 9 TONS (NO ANCHORS)		CONE TYPE: TYPE 2 PIEZOCONE	
DRILLER: EDDIE SWAIN		OPERATOR: CATLIN	
START DATE: 02/04/20		COMP. DATE: 02/04/20	
SURF. WATER DEPTH: N/A			

WBS: 47533.1.1	TIP: I-5987A	COUNTY: ROBESON/CUMBERLAND	GEOLOGIST: S. HUDSON
SITE DESCRIPTION: I-95 CUMBERLAND/ROBESON COUNTIES FROM US 301 (EXIT 22) TO I-95 BUSINESS/US 301 (EXIT 40)			GROUND WTR (ft)
BORING NO.: L_13700_LT	STATION: 137+00	OFFSET: 105 ft LT	ALIGNMENT: -L-
COLLAR ELEV.: 135.3 ft	TOTAL DEPTH: 12.5 ft	NORTHING: 338,788	EASTING: 1,999,156
CPT RIG/MAX. DOWN PRESSURE: CATLIN CPT/DPT-01 / 9 TONS (NO ANCHORS)		CONE TYPE: TYPE 2 PIEZOCONE	
DRILLER: EDDIE SWAIN		OPERATOR: CATLIN	
START DATE: 02/03/20		COMP. DATE: 02/03/20	
SURF. WATER DEPTH: N/A			

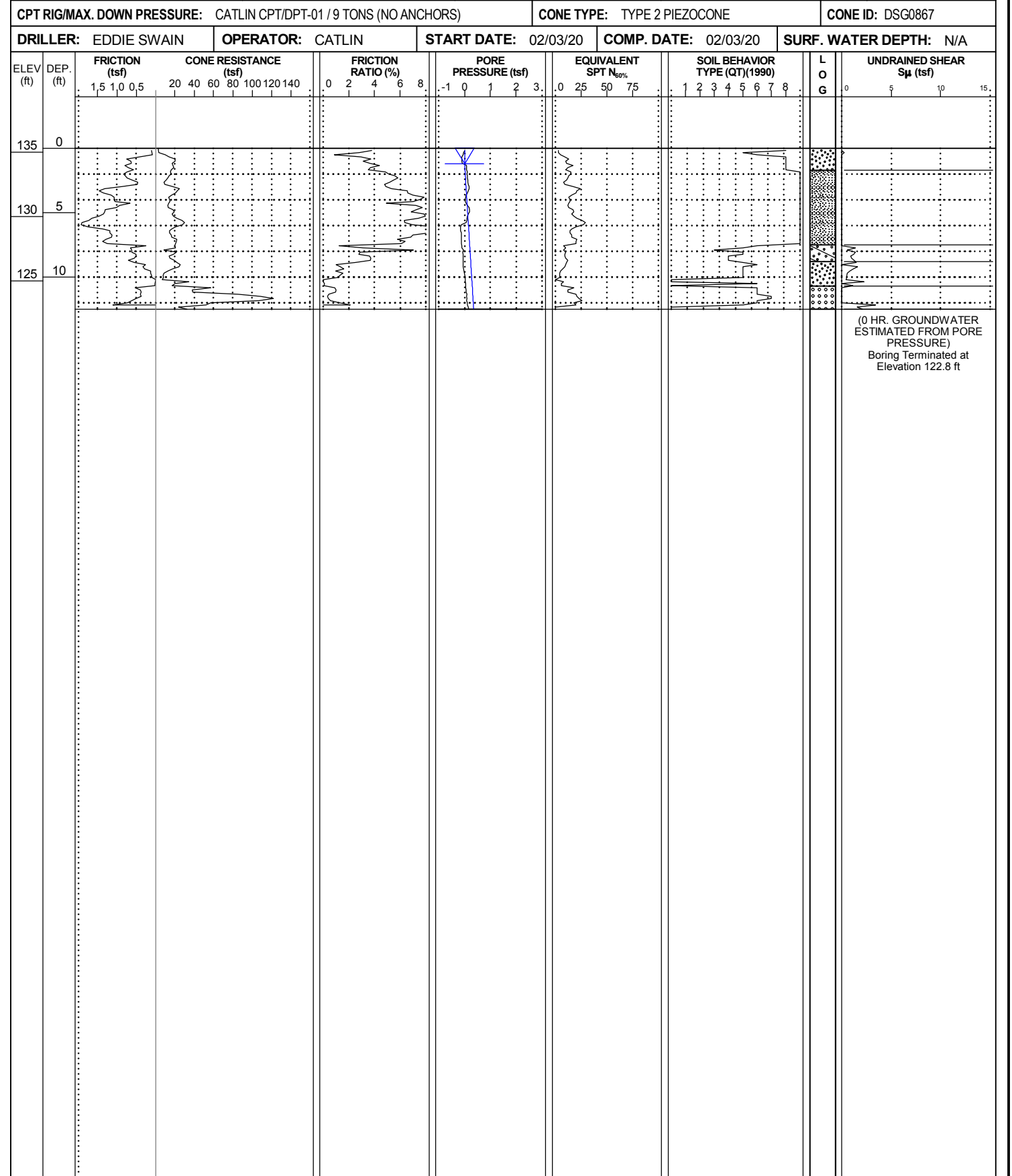
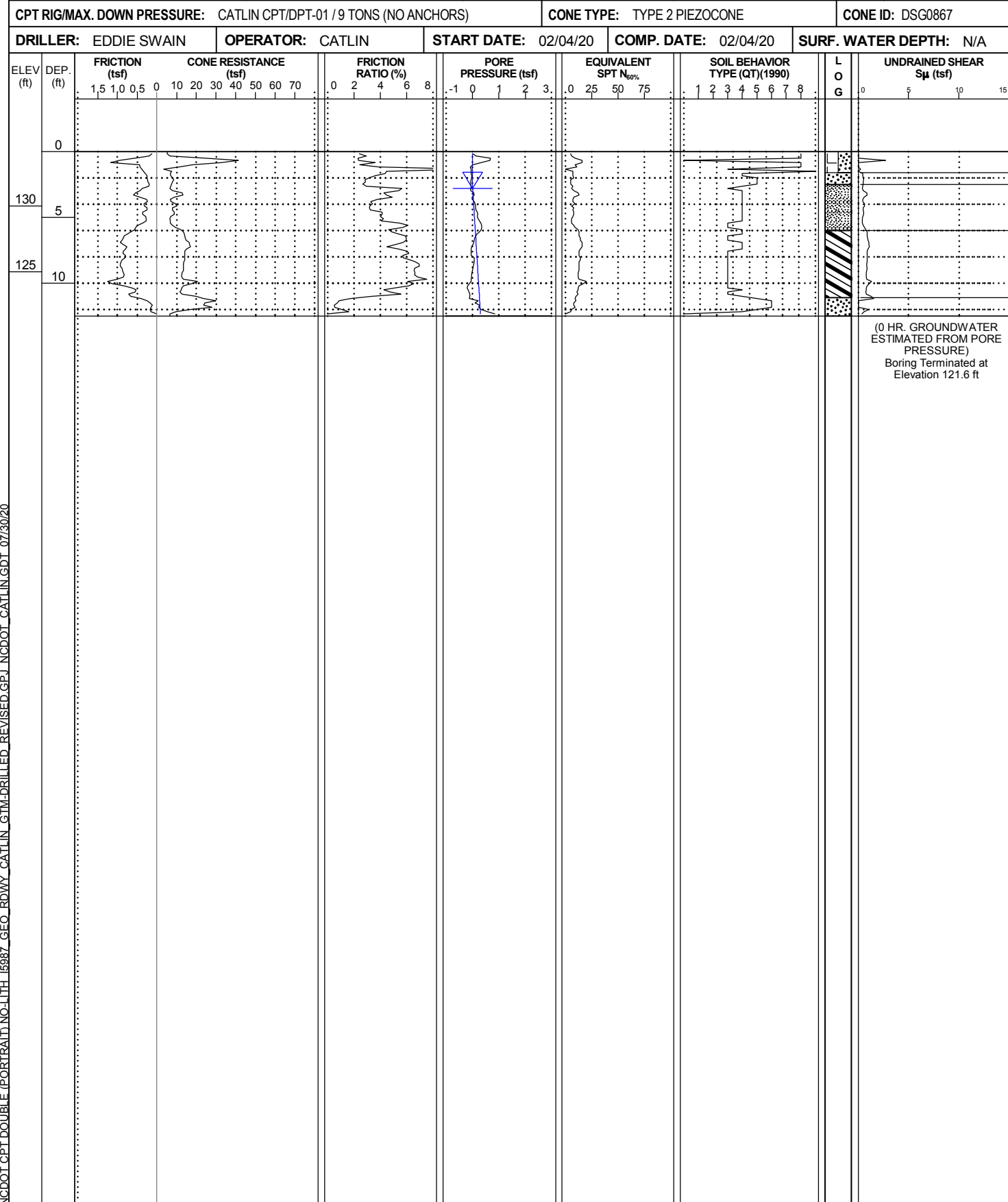

NCDOT CPT DOUBLE (PORTRAIT) NO-LITH 15987_GEO_RDWY_CATLIN_GTM-DRILLED_REVISED.GPJ NCDOT_CATLIN.GDT 07/30/20

CONE PENETROMETER TEST BORING REPORT



WBS: 47533.1.1	TIP: I-5987A	COUNTY: ROBESON/CUMBERLAND	GEOLOGIST: S. HUDSON
SITE DESCRIPTION: I-95 CUMBERLAND/ROBESON COUNTIES FROM US 301 (EXIT 22) TO I-95 BUSINESS/US 301 (EXIT 40)			GROUND WTR (ft)
BORING NO.: L_18700_RT	STATION: 187+00	OFFSET: 80 ft RT	ALIGNMENT: -L-
COLLAR ELEV.: 141.0 ft	TOTAL DEPTH: 14.5 ft	NORTHING: 343,608	EASTING: 2,000,511
CPT RIG/MAX. DOWN PRESSURE: CATLIN CPT/DPT-01 / 9 TONS (NO ANCHORS)		CONE TYPE: TYPE 2 PIEZOCONE	CONE ID: DSG0867
DRILLER: EDDIE SWAIN	OPERATOR: CATLIN	START DATE: 02/04/20	COMP. DATE: 02/04/20
		SURF. WATER DEPTH: N/A	

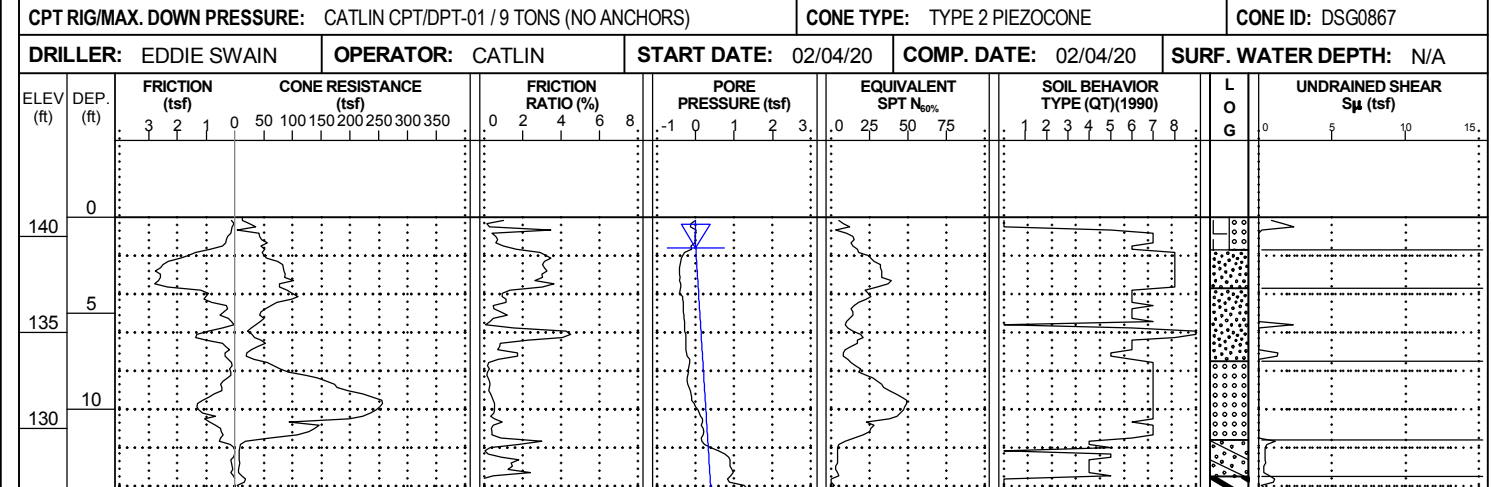

(0 HR. GROUNDWATER ESTIMATED FROM PORE PRESSURE)
Boring Terminated at Elevation 126.5 ft

WBS: 47533.1.1	TIP: I-5987A	COUNTY: ROBESON/CUMBERLAND	GEOLOGIST: S. HUDSON
SITE DESCRIPTION: I-95 CUMBERLAND/ROBESON COUNTIES FROM US 301 (EXIT 22) TO I-95 BUSINESS/US 301 (EXIT 40)			GROUND WTR (ft)
BORING NO.: L_19200_RT	STATION: 192+00	OFFSET: 86 ft RT	ALIGNMENT: -L-
COLLAR ELEV.: 142.1 ft	TOTAL DEPTH: 12.5 ft	NORTHING: 344,110	EASTING: 2,000,542
CPT RIG/MAX. DOWN PRESSURE: CATLIN CPT/DPT-01 / 9 TONS (NO ANCHORS)		CONE TYPE: TYPE 2 PIEZOCONE	CONE ID: DSG0867
DRILLER: EDDIE SWAIN	OPERATOR: CATLIN	START DATE: 02/04/20	COMP. DATE: 02/04/20
		SURF. WATER DEPTH: N/A	

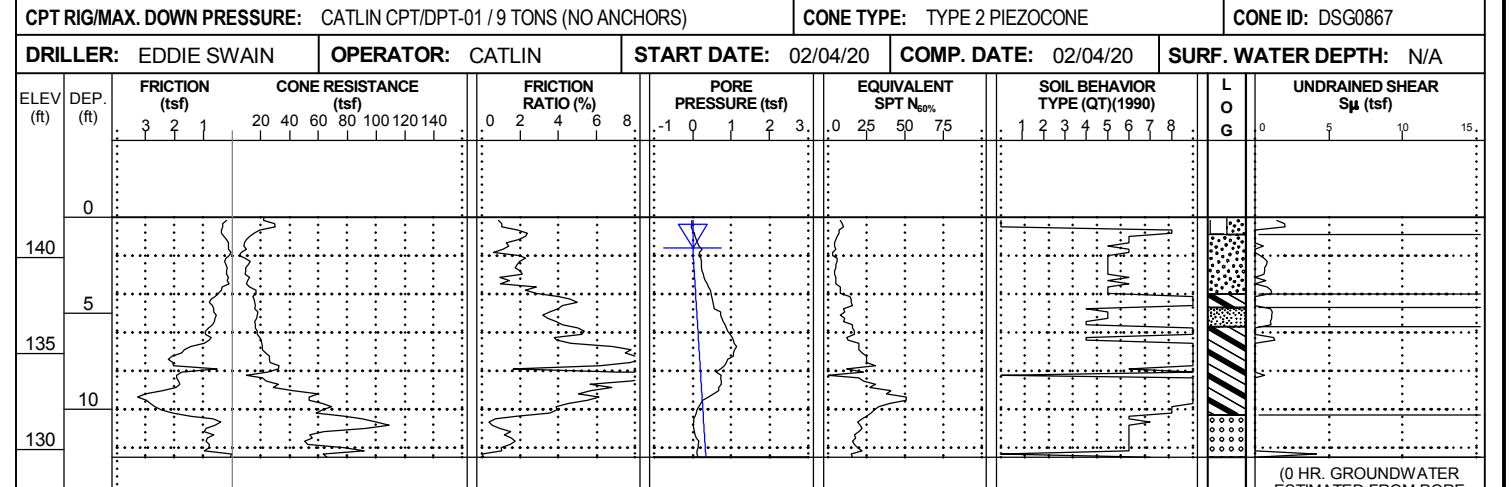

(0 HR. GROUNDWATER ESTIMATED FROM PORE PRESSURE)
Boring Terminated at Elevation 129.6 ft

NCDOT CPT DOUBLE (PORTRAIT) NO-LITH 15987_GEO_RDWY_CATLIN_GTM-DRILLED_REVISED.GPJ_NCDOT_CATLIN.GDT_07/30/20

CONE PENETROMETER TEST BORING REPORT



WBS: 47533.1.1	TIP: I-5987A	COUNTY: ROBESON/CUMBERLAND	GEOLOGIST: S. HUDSON
SITE DESCRIPTION: I-95 CUMBERLAND/ROBESON COUNTIES FROM US 301 (EXIT 22) TO I-95 BUSINESS/US 301 (EXIT 40)			GROUND WTR (ft)
BORING NO.: L_20200_LT	STATION: 202+01	OFFSET: 92 ft LT	ALIGNMENT: -L-
COLLAR ELEV.: 143.3 ft	TOTAL DEPTH: 9.1 ft	NORTHING: 345,117	EASTING: 2,000,405
CPT RIG/MAX. DOWN PRESSURE: CATLIN CPT/DPT-01 / 9 TONS (NO ANCHORS)		CONE TYPE: TYPE 2 PIEZOCONE	CONE ID: DSG0867
DRILLER: EDDIE SWAIN	OPERATOR: CATLIN	START DATE: 02/03/20	COMP. DATE: 02/03/20
EST. 0 HR. 0.8		24 HR. N/A	

WBS: 47533.1.1	TIP: I-5987A	COUNTY: ROBESON/CUMBERLAND	GEOLOGIST: S. HUDSON
SITE DESCRIPTION: I-95 CUMBERLAND/ROBESON COUNTIES FROM US 301 (EXIT 22) TO I-95 BUSINESS/US 301 (EXIT 40)			GROUND WTR (ft)
BORING NO.: L_20700_LT	STATION: 207+00	OFFSET: 86 ft LT	ALIGNMENT: -L-
COLLAR ELEV.: 144.8 ft	TOTAL DEPTH: 9.4 ft	NORTHING: 345,616	EASTING: 2,000,431
CPT RIG/MAX. DOWN PRESSURE: CATLIN CPT/DPT-01 / 9 TONS (NO ANCHORS)		CONE TYPE: TYPE 2 PIEZOCONE	CONE ID: DSG0867
DRILLER: EDDIE SWAIN	OPERATOR: CATLIN	START DATE: 02/03/20	COMP. DATE: 02/03/20
EST. 0 HR. 1.9		24 HR. N/A	

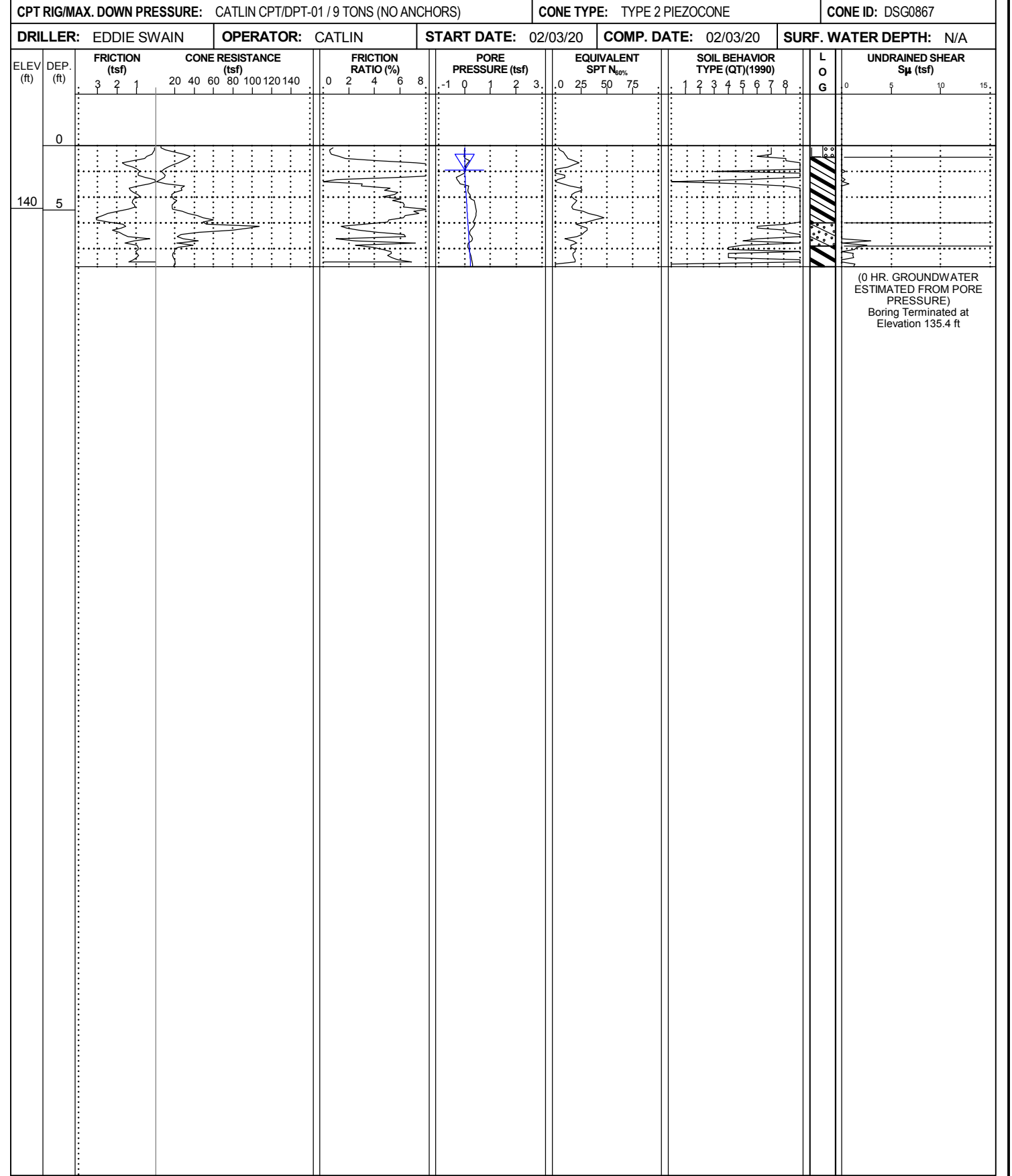
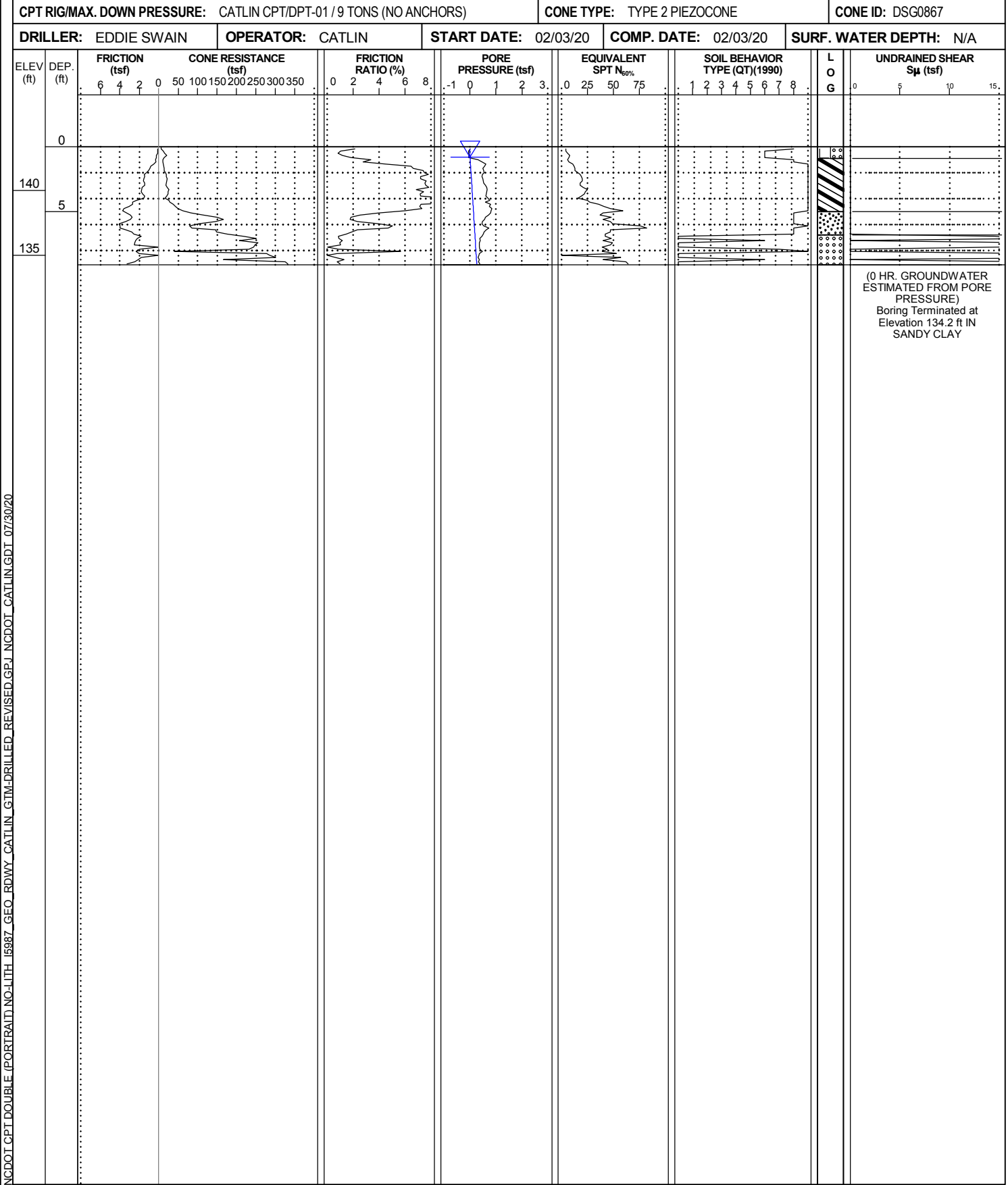

NCDOT CPT DOUBLE (PORTRAIT) NO-LITH I5987_GEO_ROWY_CATLIN_GTM-DRILLED_REVISED.GPJ NCDOT_CATLIN.GDT 07/30/20

CONE PENETROMETER TEST BORING REPORT



WBS: 47533.1.1	TIP: I-5987A	COUNTY: ROBESON/CUMBERLAND	GEOLOGIST: S. HUDSON
SITE DESCRIPTION: I-95 CUMBERLAND/ROBESON COUNTIES FROM US 301 (EXIT 22) TO I-95 BUSINESS/US 301 (EXIT 40)			GROUND WTR (ft)
BORING NO.: L_29200_LT	STATION: 292+00	OFFSET: 74 ft LT	ALIGNMENT: -L-
COLLAR ELEV.: 150.0 ft	TOTAL DEPTH: 9.5 ft	NORTHING: 354,108	EASTING: 2,000,710
CPT RIG/MAX. DOWN PRESSURE: CATLIN CPT/DPT-01 / 9 TONS (NO ANCHORS)		CONE TYPE: TYPE 2 PIEZOcone	CONE ID: DSG0867
DRILLER: EDDIE SWAIN	OPERATOR: CATLIN	START DATE: 02/03/20	COMP. DATE: 02/03/20
		SURF. WATER DEPTH: N/A	

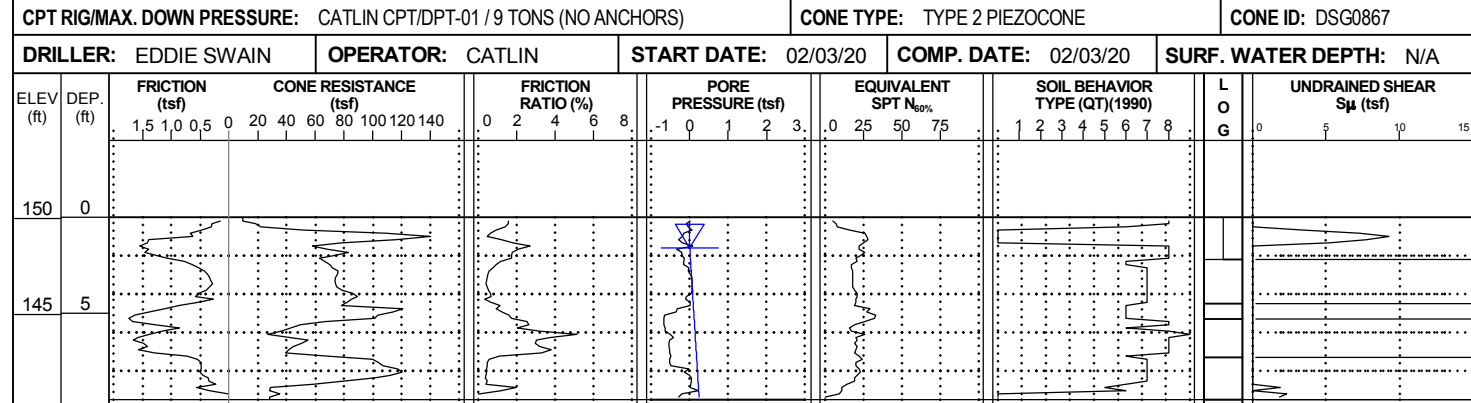

(0 HR. GROUNDWATER ESTIMATED FROM PORE PRESSURE)
Boring Terminated at Elevation 140.5 ft

WBS: 47533.1.1	TIP: I-5987A	COUNTY: ROBESON/CUMBERLAND	GEOLOGIST: S. HUDSON
SITE DESCRIPTION: I-95 CUMBERLAND/ROBESON COUNTIES FROM US 301 (EXIT 22) TO I-95 BUSINESS/US 301 (EXIT 40)			GROUND WTR (ft)
BORING NO.: L_29700_LT	STATION: 297+00	OFFSET: 77 ft LT	ALIGNMENT: -L-
COLLAR ELEV.: 148.6 ft	TOTAL DEPTH: 12.4 ft	NORTHING: 354,608	EASTING: 2,000,712
CPT RIG/MAX. DOWN PRESSURE: CATLIN CPT/DPT-01 / 9 TONS (NO ANCHORS)		CONE TYPE: TYPE 2 PIEZOcone	CONE ID: DSG0867
DRILLER: EDDIE SWAIN	OPERATOR: CATLIN	START DATE: 01/30/20	COMP. DATE: 01/31/20
		SURF. WATER DEPTH: N/A	

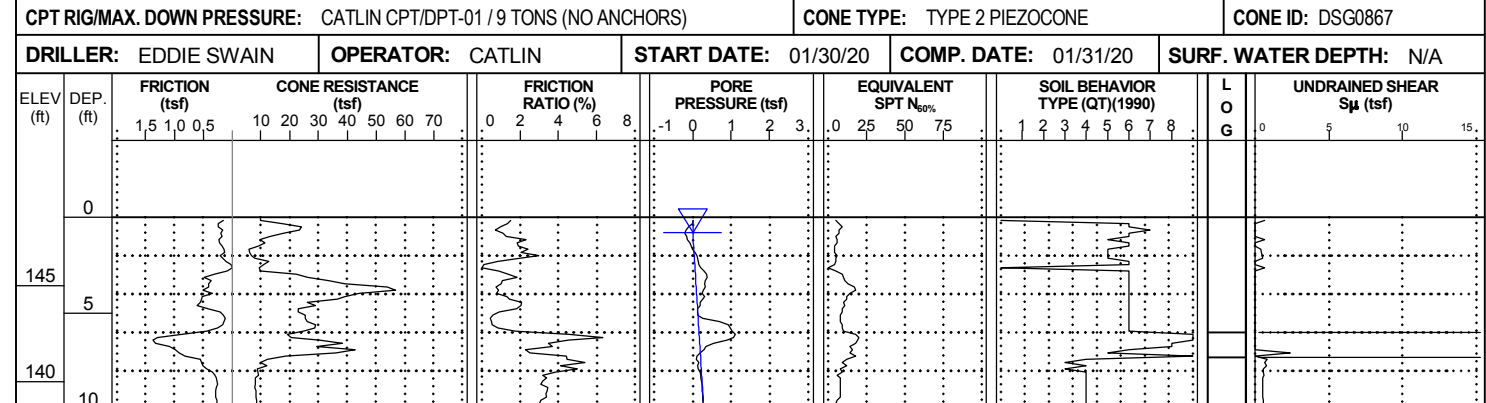

(0 HR. GROUNDWATER ESTIMATED FROM PORE PRESSURE)
Boring Terminated at Elevation 136.2 ft

NCDOI CPT DOUBLE (PORTRAIT) NO-LITH 15987_GEO_ROWY_CATLIN_GTM-DRILLED_REVISED.GPJ_NCDOT_CATLIN.GDT_07/30/20

CONE PENETROMETER TEST BORING REPORT



WBS: 47533.1.1	TIP: I-5987A	COUNTY: ROBESON/CUMBERLAND	GEOLOGIST: S. HUDSON
SITE DESCRIPTION: I-95 CUMBERLAND/ROBESON COUNTIES FROM US 301 (EXIT 22) TO I-95 BUSINESS/US 301 (EXIT 40)			GROUND WTR (ft)
BORING NO.: L_30200_LT	STATION: 302+00	OFFSET: 82 ft LT	ALIGNMENT: -L-
COLLAR ELEV.: 147.6 ft	TOTAL DEPTH: 14.4 ft	NORTHING: 355,108	EASTING: 2,000,711
CPT RIG/MAX. DOWN PRESSURE: CATLIN CPT/DPT-01 / 9 TONS (NO ANCHORS)		CONE TYPE: TYPE 2 PIEZOCONE	CONE ID: DSG0867
DRILLER: EDDIE SWAIN	OPERATOR: CATLIN	START DATE: 01/30/20	COMP. DATE: 01/31/20
		SURF. WATER DEPTH: N/A	

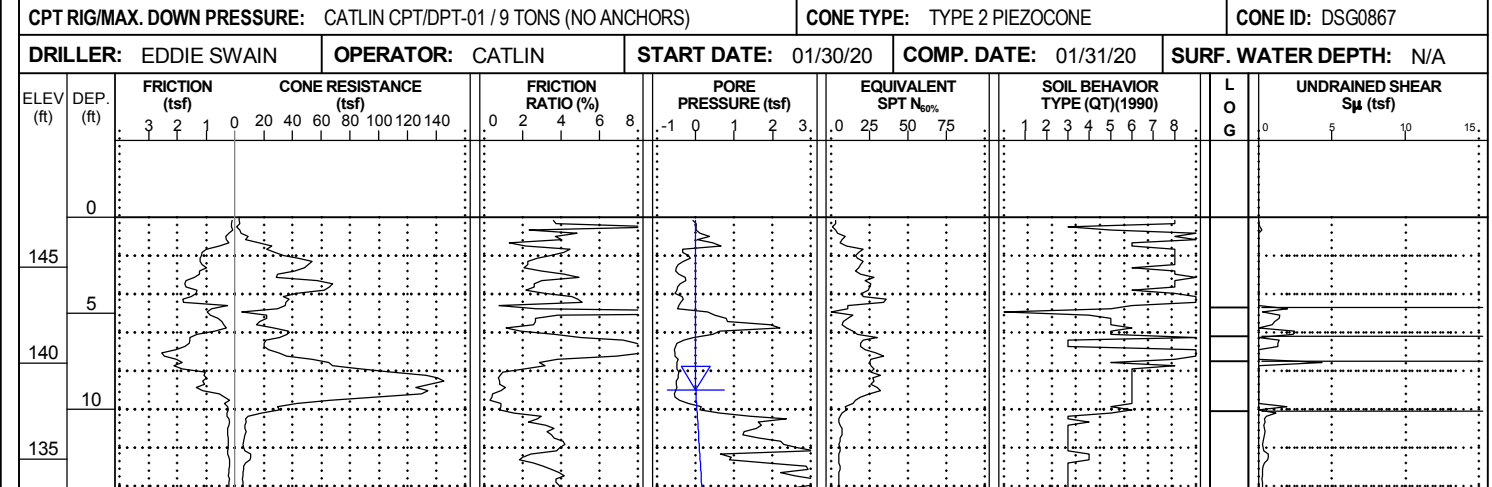

(0 HR. GROUNDWATER ESTIMATED FROM PORE PRESSURE)
Boring Terminated at Elevation 133.2 ft

WBS: 47533.1.1	TIP: I-5987A	COUNTY: ROBESON/CUMBERLAND	GEOLOGIST: S. HUDSON
SITE DESCRIPTION: I-95 CUMBERLAND/ROBESON COUNTIES FROM US 301 (EXIT 22) TO I-95 BUSINESS/US 301 (EXIT 40)			GROUND WTR (ft)
BORING NO.: L_30700_LT	STATION: 307+00	OFFSET: 92 ft LT	ALIGNMENT: -L-
COLLAR ELEV.: 147.6 ft	TOTAL DEPTH: 9.6 ft	NORTHING: 355,608	EASTING: 2,000,705
CPT RIG/MAX. DOWN PRESSURE: CATLIN CPT/DPT-01 / 9 TONS (NO ANCHORS)		CONE TYPE: TYPE 2 PIEZOCONE	CONE ID: DSG0867
DRILLER: EDDIE SWAIN	OPERATOR: CATLIN	START DATE: 01/30/20	COMP. DATE: 01/31/20
		SURF. WATER DEPTH: N/A	

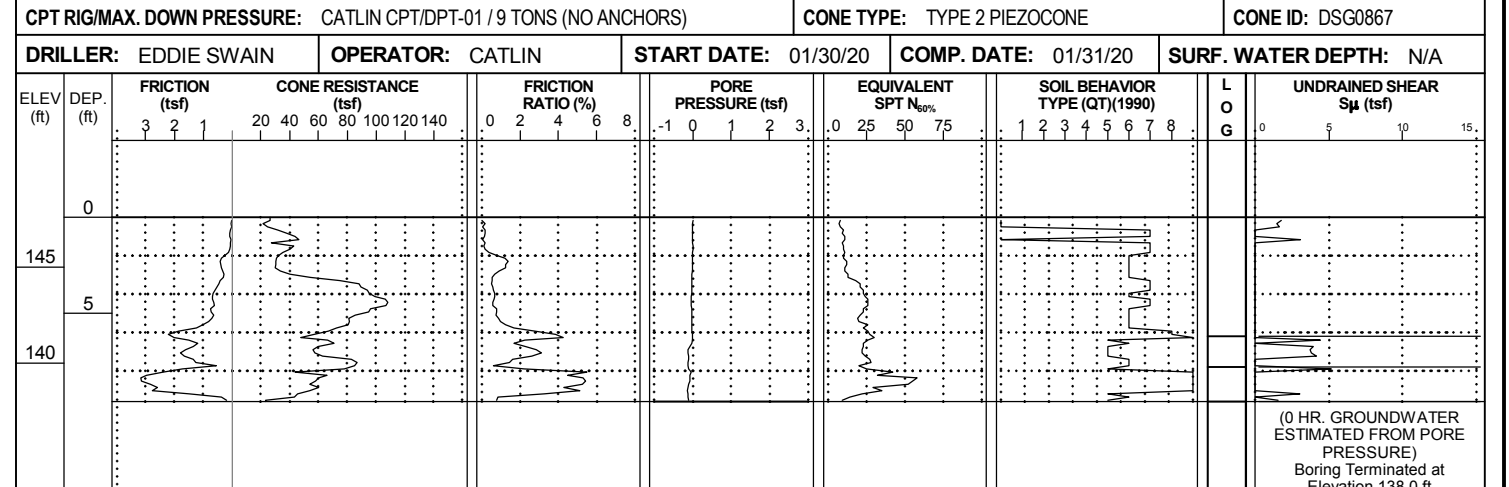

(0 HR. GROUNDWATER ESTIMATED FROM PORE PRESSURE)
Boring Terminated at Elevation 138.0 ft

NCDOT CPT DOUBLE (PORTRAIT) NO-LITH 15987_GEO_ROWY_CATLIN_GTM-DRILLED_REVISED.GPJ_NCDOT_CATLIN.GDT_07/30/20

CONE PENETROMETER TEST BORING REPORT



WBS: 47533.1.1	TIP: I-5987A	COUNTY: ROBESON/CUMBERLAND	GEOLOGIST: S. HUDSON
SITE DESCRIPTION: I-95 CUMBERLAND/ROBESON COUNTIES FROM US 301 (EXIT 22) TO I-95 BUSINESS/US 301 (EXIT 40)			GROUND WTR (ft)
BORING NO.: L_31700_RT	STATION: 317+00	OFFSET: 86 ft RT	ALIGNMENT: -L-
COLLAR ELEV.: 140.1 ft	TOTAL DEPTH: 16.1 ft	NORTHING: 356,606	EASTING: 2,000,892
CPT RIG/MAX. DOWN PRESSURE: CATLIN CPT/DPT-01 / 9 TONS (NO ANCHORS)		CONE TYPE: TYPE 2 PIEZOCONE	
DRILLER: EDDIE SWAIN		OPERATOR: CATLIN	
START DATE: 12/16/19		COMP. DATE: 12/16/19	
SURF. WATER DEPTH: N/A		EST. 0 HR. 2.5	
24 HR. N/A			

WBS: 47533.1.1	TIP: I-5987A	COUNTY: ROBESON/CUMBERLAND	GEOLOGIST: S. HUDSON
SITE DESCRIPTION: I-95 CUMBERLAND/ROBESON COUNTIES FROM US 301 (EXIT 22) TO I-95 BUSINESS/US 301 (EXIT 40)			GROUND WTR (ft)
BORING NO.: L_32200_RT	STATION: 322+00	OFFSET: 91 ft RT	ALIGNMENT: -L-
COLLAR ELEV.: 146.3 ft	TOTAL DEPTH: 10.6 ft	NORTHING: 357,106	EASTING: 2,000,901
CPT RIG/MAX. DOWN PRESSURE: CATLIN CPT/DPT-01 / 9 TONS (NO ANCHORS)		CONE TYPE: TYPE 2 PIEZOCONE	
DRILLER: EDDIE SWAIN		OPERATOR: CATLIN	
START DATE: 12/16/19		COMP. DATE: 12/16/19	
SURF. WATER DEPTH: N/A		EST. 0 HR. 4.8	
24 HR. N/A			

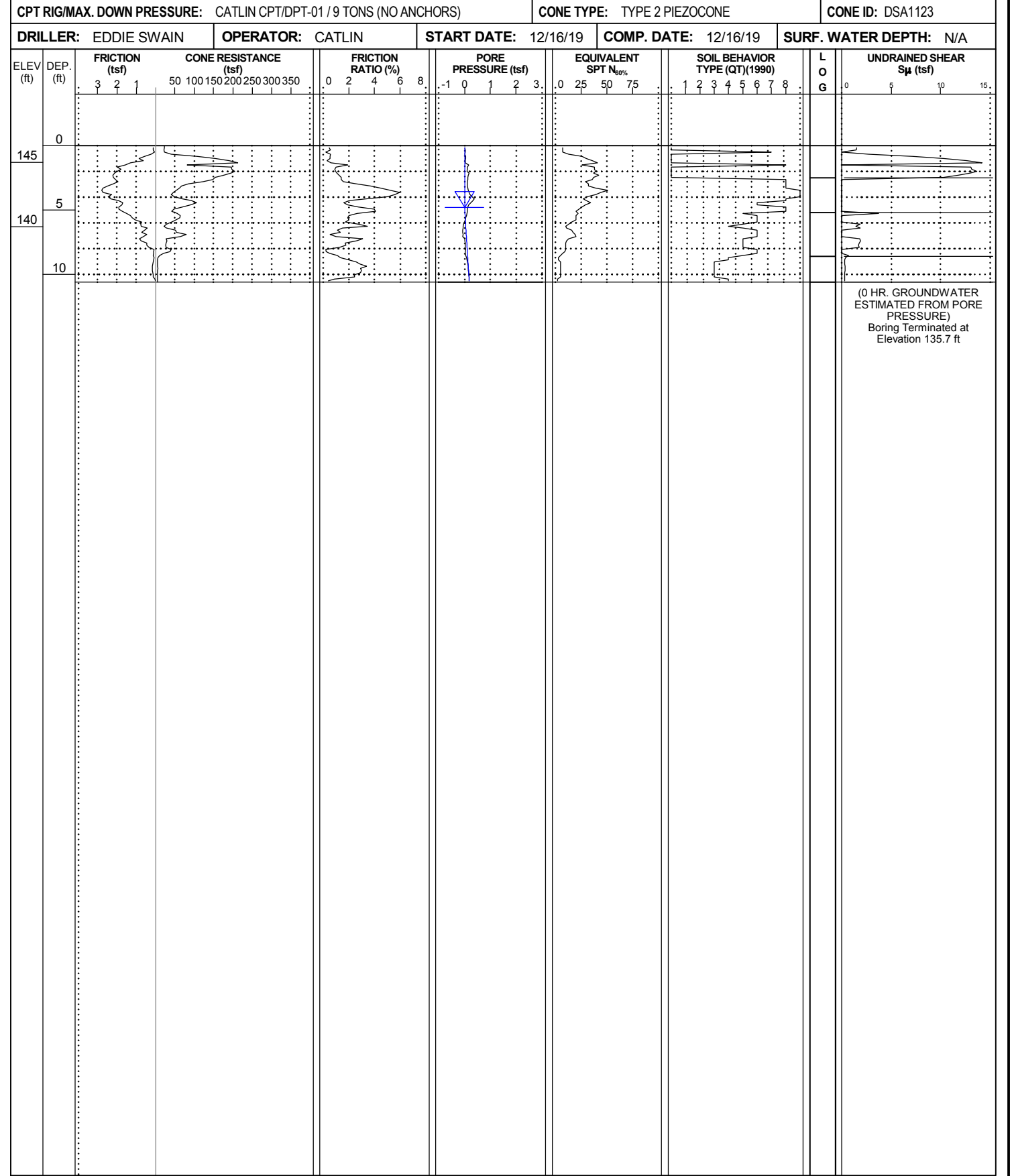
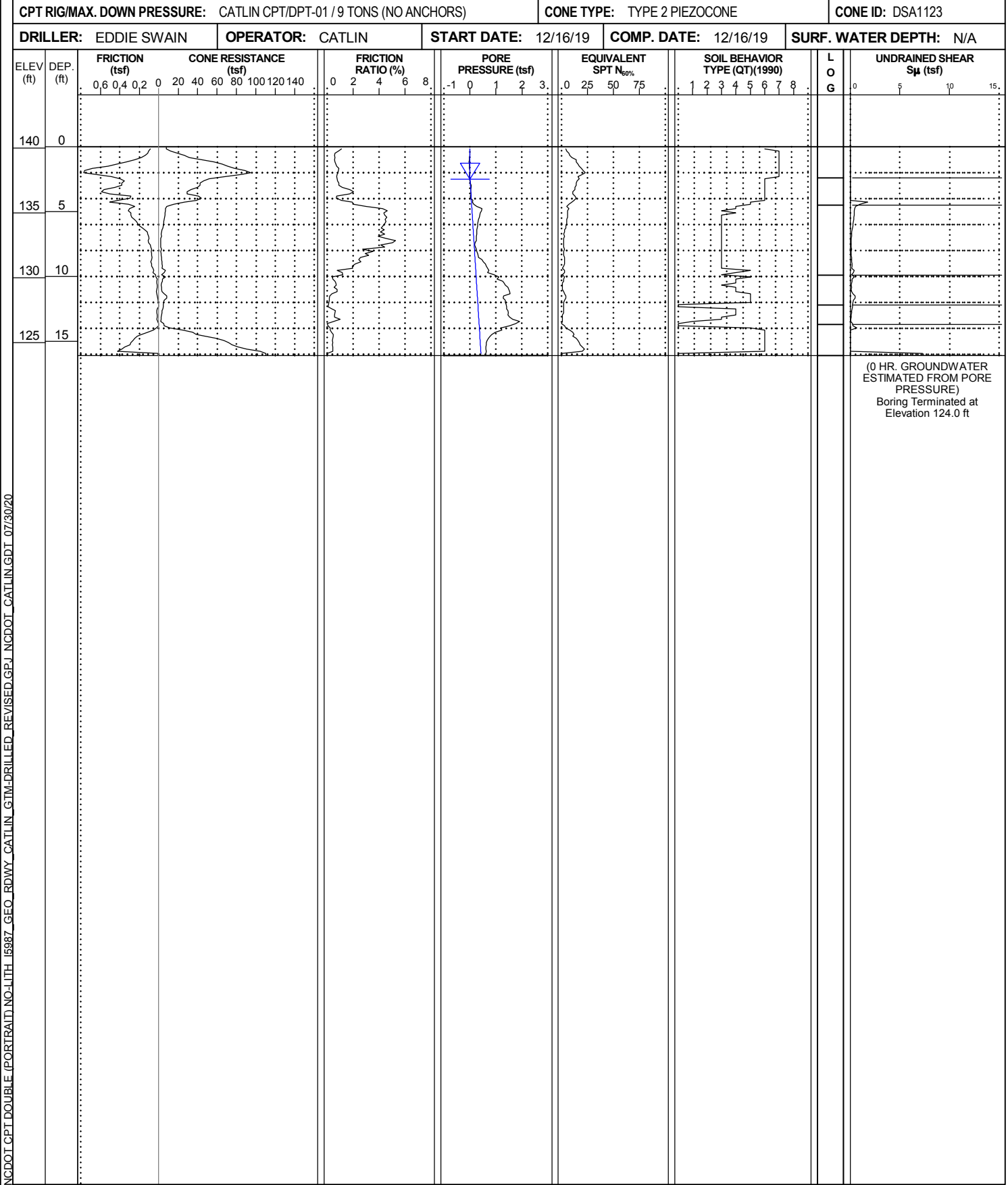

NCDOT CPT DOUBLE (PORTRAIT) NO-LITH 15987_GEO_ROWY_CATLIN_GTM-DRILLED_REVISED.GPJ NCDOT_CATLIN.GDT_07/30/20

CONE PENETROMETER TEST BORING REPORT



WBS: 47533.1.1	TIP: I-5987A	COUNTY: ROBESON/CUMBERLAND	GEOLOGIST: S. HUDSON
SITE DESCRIPTION: I-95 CUMBERLAND/ROBESON COUNTIES FROM US 301 (EXIT 22) TO I-95 BUSINESS/US 301 (EXIT 40)			GROUND WTR (ft)
BORING NO.: L_32700_RT	STATION: 327+00	OFFSET: 90 ft RT	ALIGNMENT: -L-
COLLAR ELEV.: 149.3 ft	TOTAL DEPTH: 14.0 ft	NORTHING: 357,606	EASTING: 2,000,904
CPT RIG/MAX. DOWN PRESSURE: CATLIN CPT/DPT-01 / 9 TONS (NO ANCHORS)		CONE TYPE: TYPE 2 PIEZOCONE	
DRILLER: EDDIE SWAIN		OPERATOR: CATLIN	
START DATE: 12/16/19		COMP. DATE: 12/16/19	
SURF. WATER DEPTH: N/A		EST. 0 HR. 5.1	
24 HR. N/A			

WBS: 47533.1.1	TIP: I-5987A	COUNTY: ROBESON/CUMBERLAND	GEOLOGIST: S. HUDSON
SITE DESCRIPTION: I-95 CUMBERLAND/ROBESON COUNTIES FROM US 301 (EXIT 22) TO I-95 BUSINESS/US 301 (EXIT 40)			GROUND WTR (ft)
BORING NO.: L_33200_RT	STATION: 332+00	OFFSET: 91 ft RT	ALIGNMENT: -L-
COLLAR ELEV.: 148.4 ft	TOTAL DEPTH: 14.7 ft	NORTHING: 358,106	EASTING: 2,000,910
CPT RIG/MAX. DOWN PRESSURE: CATLIN CPT/DPT-01 / 9 TONS (NO ANCHORS)		CONE TYPE: TYPE 2 PIEZOCONE	
DRILLER: EDDIE SWAIN		OPERATOR: CATLIN	
START DATE: 12/17/19		COMP. DATE: 12/17/19	
SURF. WATER DEPTH: N/A		EST. 0 HR. 0.5	
24 HR. N/A			

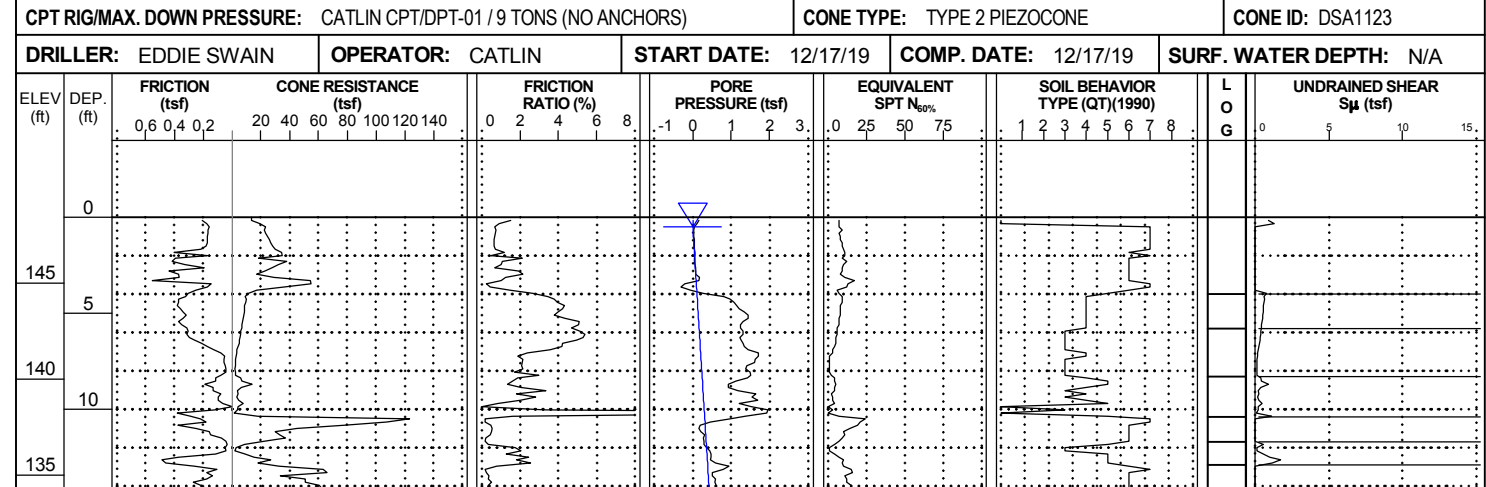
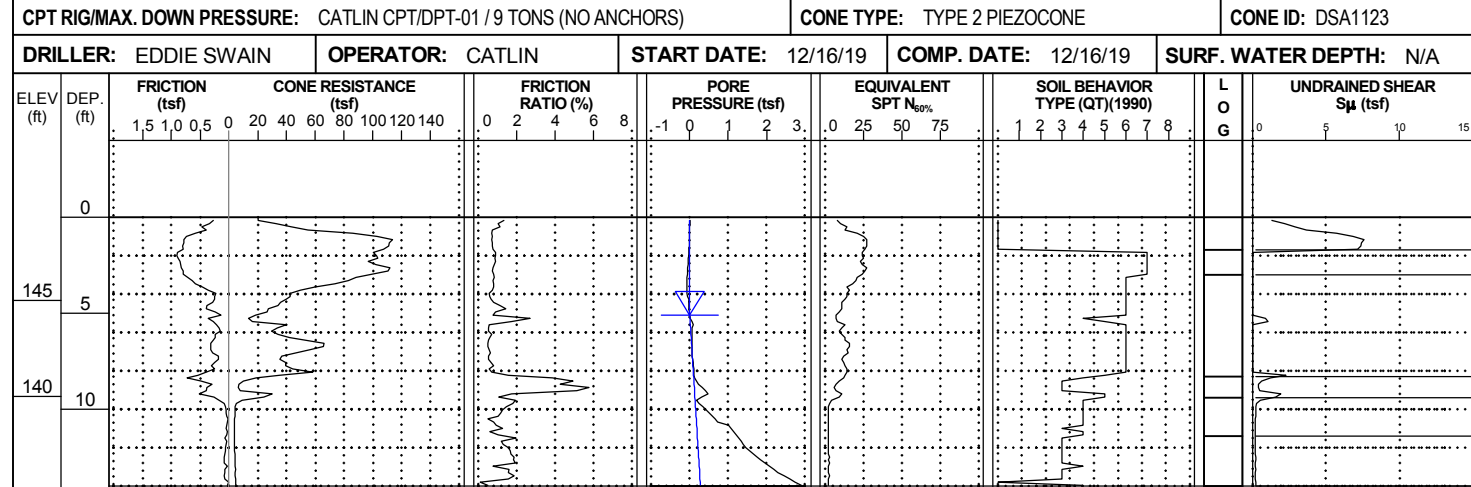

(0 HR. GROUNDWATER ESTIMATED FROM PORE PRESSURE)
Boring Terminated at Elevation 135.3 ft

(0 HR. GROUNDWATER ESTIMATED FROM PORE PRESSURE)
Boring Terminated at Elevation 133.7 ft

NCDOT CPT DOUBLE (PORTRAIT) NO-LITH 15987_GEO_RDWY_CATLIN_GTM-DRILLED_REVISED.GPJ_NCDOT_CATLIN.GDT_07/30/20

CONE PENETROMETER TEST BORING REPORT



WBS: 47533.1.1	TIP: I-5987A	COUNTY: ROBESON/CUMBERLAND	GEOLOGIST: S. HUDSON
SITE DESCRIPTION: I-95 CUMBERLAND/ROBESON COUNTIES FROM US 301 (EXIT 22) TO I-95 BUSINESS/US 301 (EXIT 40)			GROUND WTR (ft)
BORING NO.: L_33700_RT	STATION: 337+00	OFFSET: 76 ft RT	ALIGNMENT: -L-
COLLAR ELEV.: 146.4 ft	TOTAL DEPTH: 13.8 ft	NORTHING: 358,606	EASTING: 2,000,899
CPT RIG/MAX. DOWN PRESSURE: CATLIN CPT/DPT-01 / 9 TONS (NO ANCHORS)		CONE TYPE: TYPE 2 PIEZOCONE	CONE ID: DSA1123
DRILLER: EDDIE SWAIN	OPERATOR: CATLIN	START DATE: 12/18/19	COMP. DATE: 12/18/19
EST. 0 HR. 2.3		24 HR. N/A	

WBS: 47533.1.1	TIP: I-5987A	COUNTY: ROBESON/CUMBERLAND	GEOLOGIST: S. HUDSON
SITE DESCRIPTION: I-95 CUMBERLAND/ROBESON COUNTIES FROM US 301 (EXIT 22) TO I-95 BUSINESS/US 301 (EXIT 40)			GROUND WTR (ft)
BORING NO.: L_34200_RT	STATION: 342+00	OFFSET: 82 ft RT	ALIGNMENT: -L-
COLLAR ELEV.: 143.4 ft	TOTAL DEPTH: 13.5 ft	NORTHING: 359,106	EASTING: 2,000,909
CPT RIG/MAX. DOWN PRESSURE: CATLIN CPT/DPT-01 / 9 TONS (NO ANCHORS)		CONE TYPE: TYPE 2 PIEZOCONE	CONE ID: DSA1123
DRILLER: EDDIE SWAIN	OPERATOR: CATLIN	START DATE: 12/18/19	COMP. DATE: 12/18/19
EST. 0 HR. 0.8		24 HR. N/A	

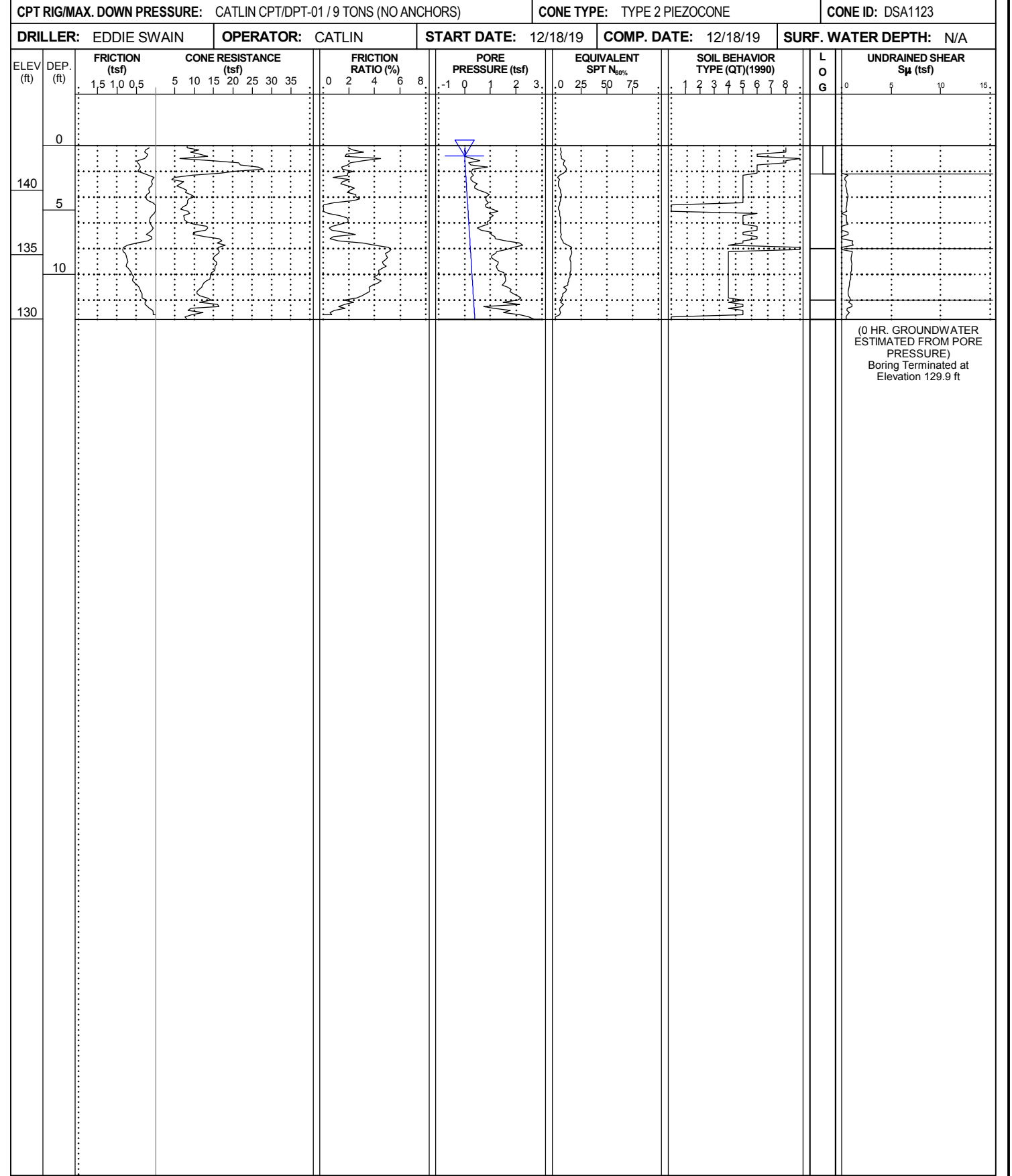
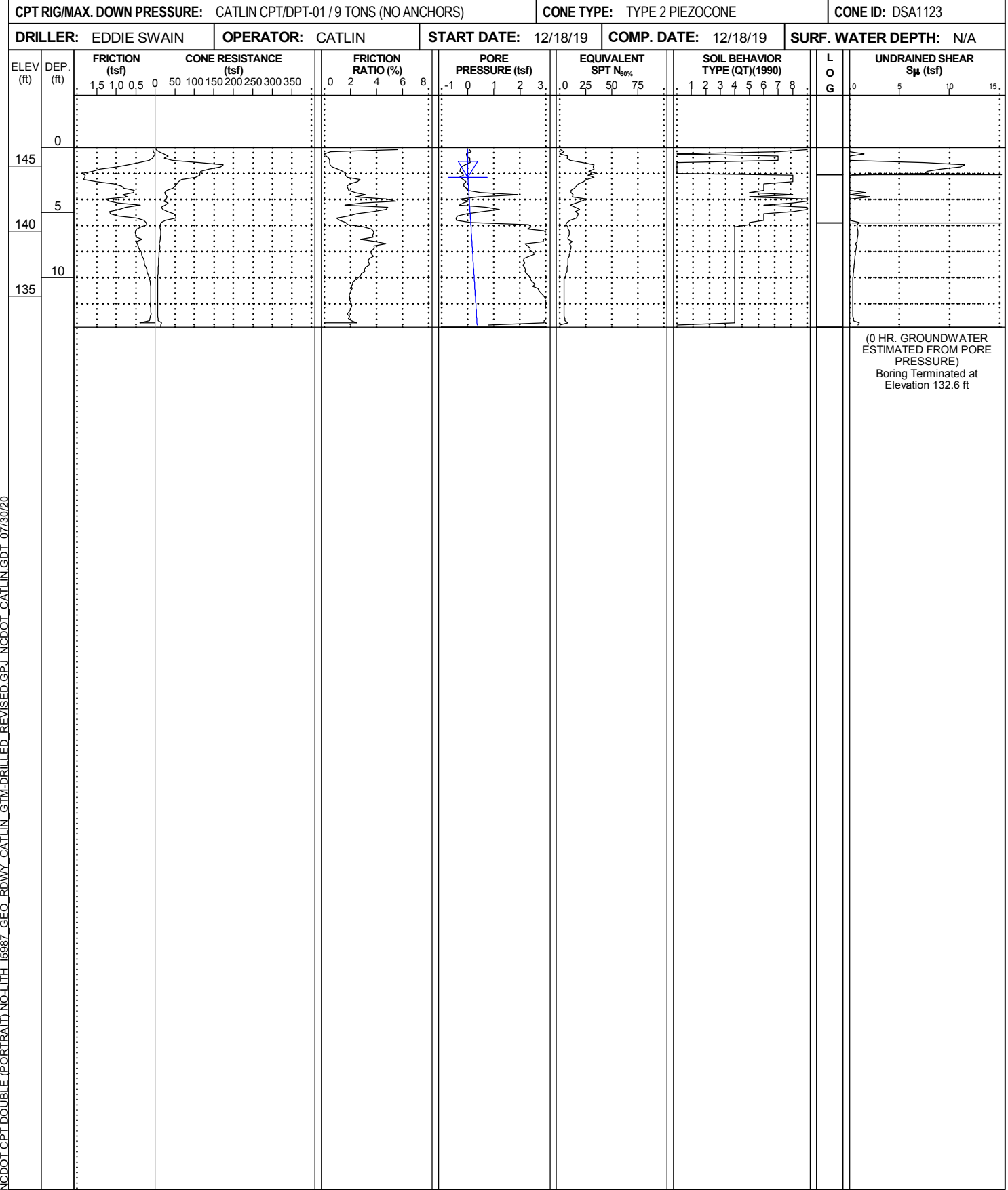

NCDOT CPT DOUBLE (PORTRAIT) NO-LITH 15987_GEO_ROWY_CATLIN_GTM-DRILLED_REVISED.GPJ NCDOT_CATLIN.GDT 07/30/20

CONE PENETROMETER TEST BORING REPORT



WBS: 47533.1.1	TIP: I-5987A	COUNTY: ROBESON/CUMBERLAND	GEOLOGIST: S. HUDSON
SITE DESCRIPTION: I-95 CUMBERLAND/ROBESON COUNTIES FROM US 301 (EXIT 22) TO I-95 BUSINESS/US 301 (EXIT 40)			GROUND WTR (ft)
BORING NO.: L_34700_RT	STATION: 347+00	OFFSET: 91 ft RT	ALIGNMENT: -L-
COLLAR ELEV.: 144.2 ft	TOTAL DEPTH: 13.6 ft	NORTHING: 359,606	EASTING: 2,000,923
CPT RIG/MAX. DOWN PRESSURE: CATLIN CPT/DPT-01 / 9 TONS (NO ANCHORS)		CONE TYPE: TYPE 2 PIEZOCONE	
DRILLER: EDDIE SWAIN		OPERATOR: CATLIN	
START DATE: 12/18/19		COMP. DATE: 12/18/19	
SURF. WATER DEPTH: N/A		EST. 0 HR. 1.3	
24 HR. N/A			

WBS: 47533.1.1	TIP: I-5987A	COUNTY: ROBESON/CUMBERLAND	GEOLOGIST: S. HUDSON
SITE DESCRIPTION: I-95 CUMBERLAND/ROBESON COUNTIES FROM US 301 (EXIT 22) TO I-95 BUSINESS/US 301 (EXIT 40)			GROUND WTR (ft)
BORING NO.: L_35300_RT	STATION: 353+00	OFFSET: 86 ft RT	ALIGNMENT: -L-
COLLAR ELEV.: 146.2 ft	TOTAL DEPTH: 10.4 ft	NORTHING: 360,206	EASTING: 2,000,923
CPT RIG/MAX. DOWN PRESSURE: CATLIN CPT/DPT-01 / 9 TONS (NO ANCHORS)		CONE TYPE: TYPE 2 PIEZOCONE	
DRILLER: EDDIE SWAIN		OPERATOR: CATLIN	
START DATE: 12/18/19		COMP. DATE: 12/18/19	
SURF. WATER DEPTH: N/A		EST. 0 HR. 0.8	
24 HR. N/A			

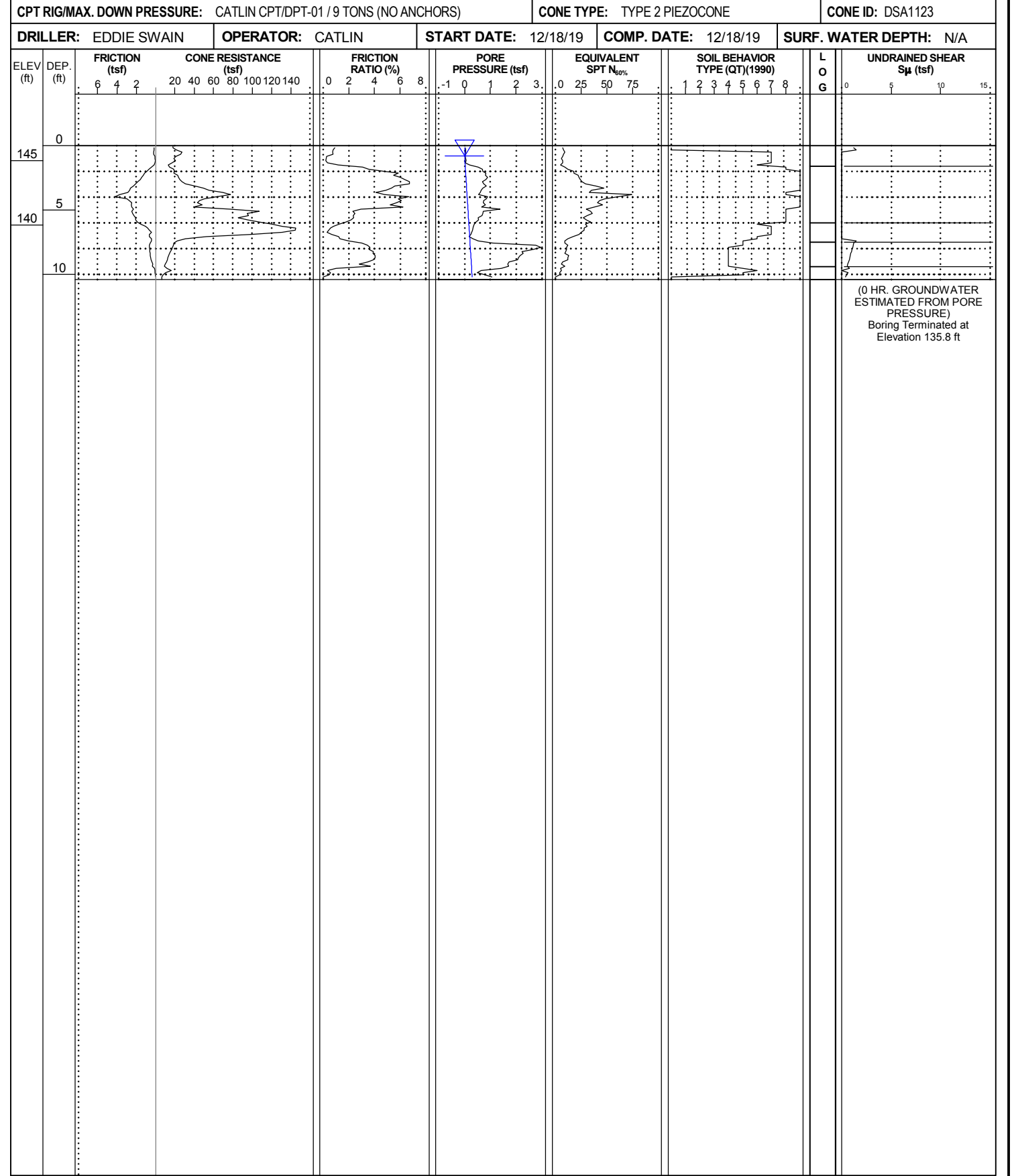
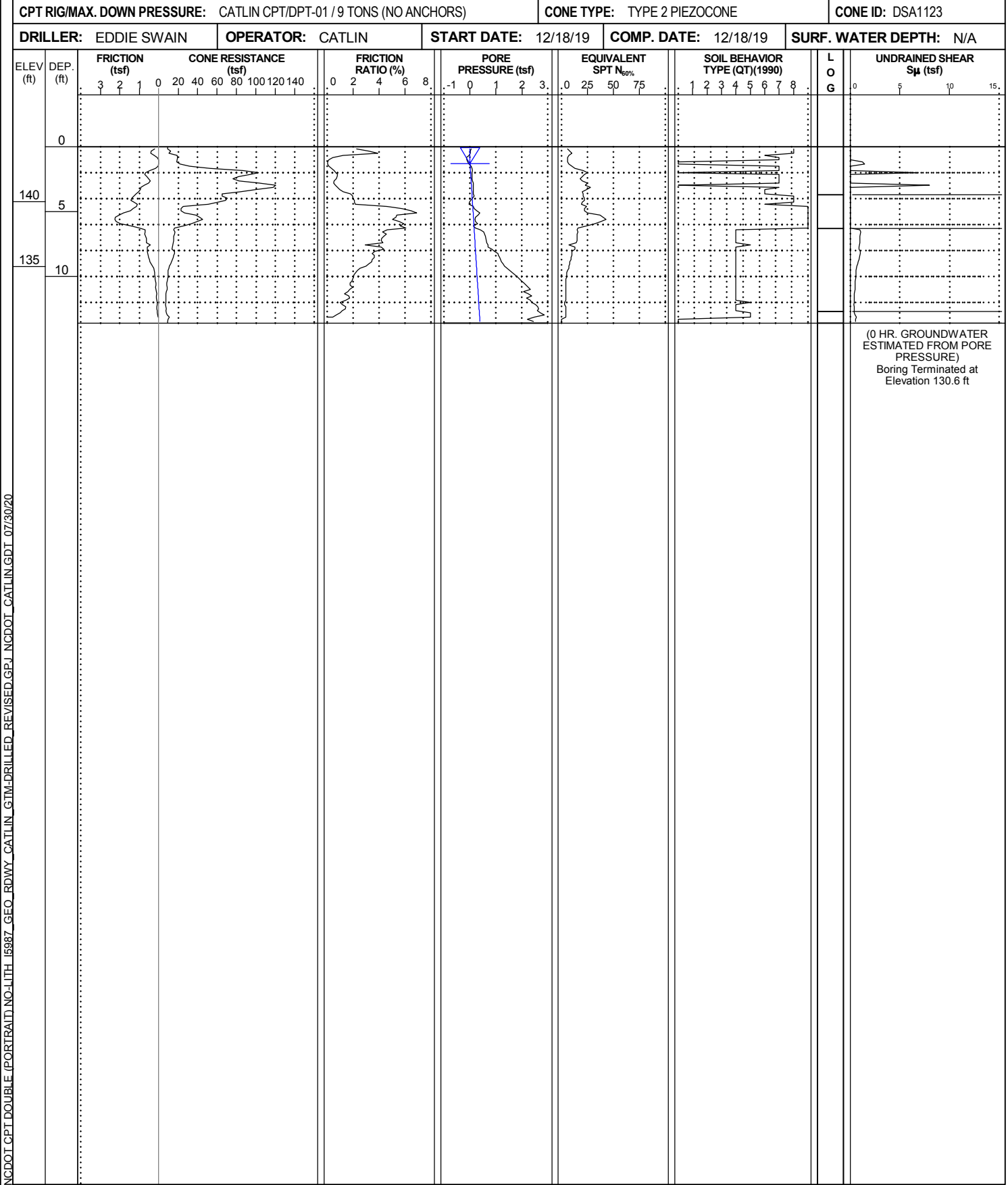

NCDOT CPT DOUBLE (PORTRAIT) NO-LITH I5987_GEO_ROWY_CATLIN_GTM-DRILLED_REVISED.GPJ NCDOT_CATLIN.GDT_07/30/20

CONE PENETROMETER TEST BORING REPORT



WBS: 47533.1.1	TIP: I-5987A	COUNTY: ROBESON/CUMBERLAND	GEOLOGIST: S. HUDSON
SITE DESCRIPTION: I-95 CUMBERLAND/ROBESON COUNTIES FROM US 301 (EXIT 22) TO I-95 BUSINESS/US 301 (EXIT 40)			GROUND WTR (ft)
BORING NO.: L_35800_LT	STATION: 358+00	OFFSET: 77 ft LT	ALIGNMENT: -L-
COLLAR ELEV.: 147.2 ft	TOTAL DEPTH: 12.6 ft	NORTHING: 360,708	EASTING: 2,000,764
CPT RIG/MAX. DOWN PRESSURE: CATLIN CPT/DPT-01 / 9 TONS (NO ANCHORS)		CONE TYPE: TYPE 2 PIEZOCONE	CONE ID: DSG0867
DRILLER: EDDIE SWAIN	OPERATOR: CATLIN	START DATE: 01/30/20	COMP. DATE: 01/31/20
		SURF. WATER DEPTH: N/A	

WBS: 47533.1.1	TIP: I-5987A	COUNTY: ROBESON/CUMBERLAND	GEOLOGIST: S. HUDSON
SITE DESCRIPTION: I-95 CUMBERLAND/ROBESON COUNTIES FROM US 301 (EXIT 22) TO I-95 BUSINESS/US 301 (EXIT 40)			GROUND WTR (ft)
BORING NO.: L_36300_LT	STATION: 363+00	OFFSET: 78 ft LT	ALIGNMENT: -L-
COLLAR ELEV.: 146.7 ft	TOTAL DEPTH: 12.4 ft	NORTHING: 361,208	EASTING: 2,000,767
CPT RIG/MAX. DOWN PRESSURE: CATLIN CPT/DPT-01 / 9 TONS (NO ANCHORS)		CONE TYPE: TYPE 2 PIEZOCONE	CONE ID: DSG0867
DRILLER: EDDIE SWAIN	OPERATOR: CATLIN	START DATE: 01/30/20	COMP. DATE: 01/31/20
		SURF. WATER DEPTH: N/A	

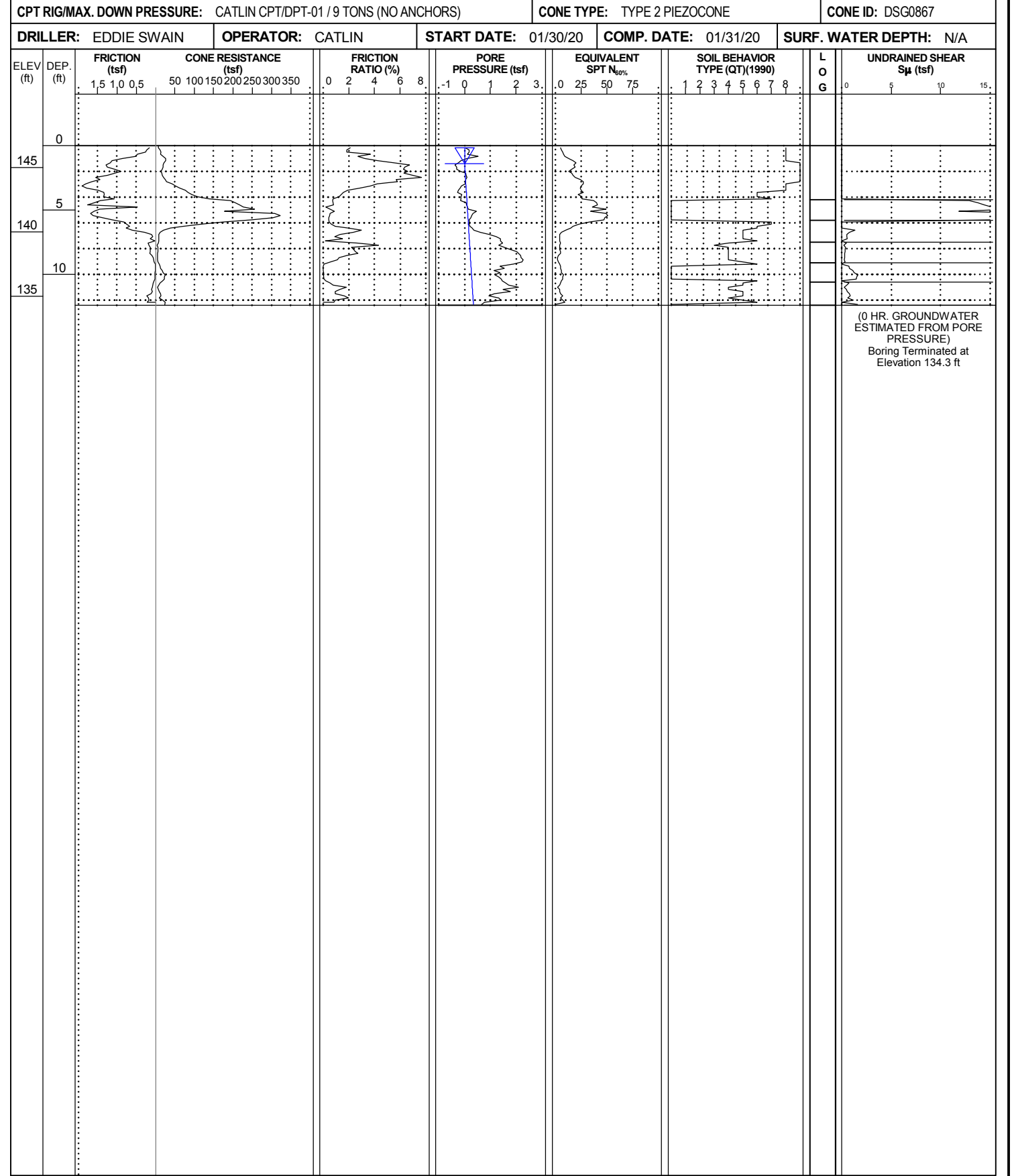
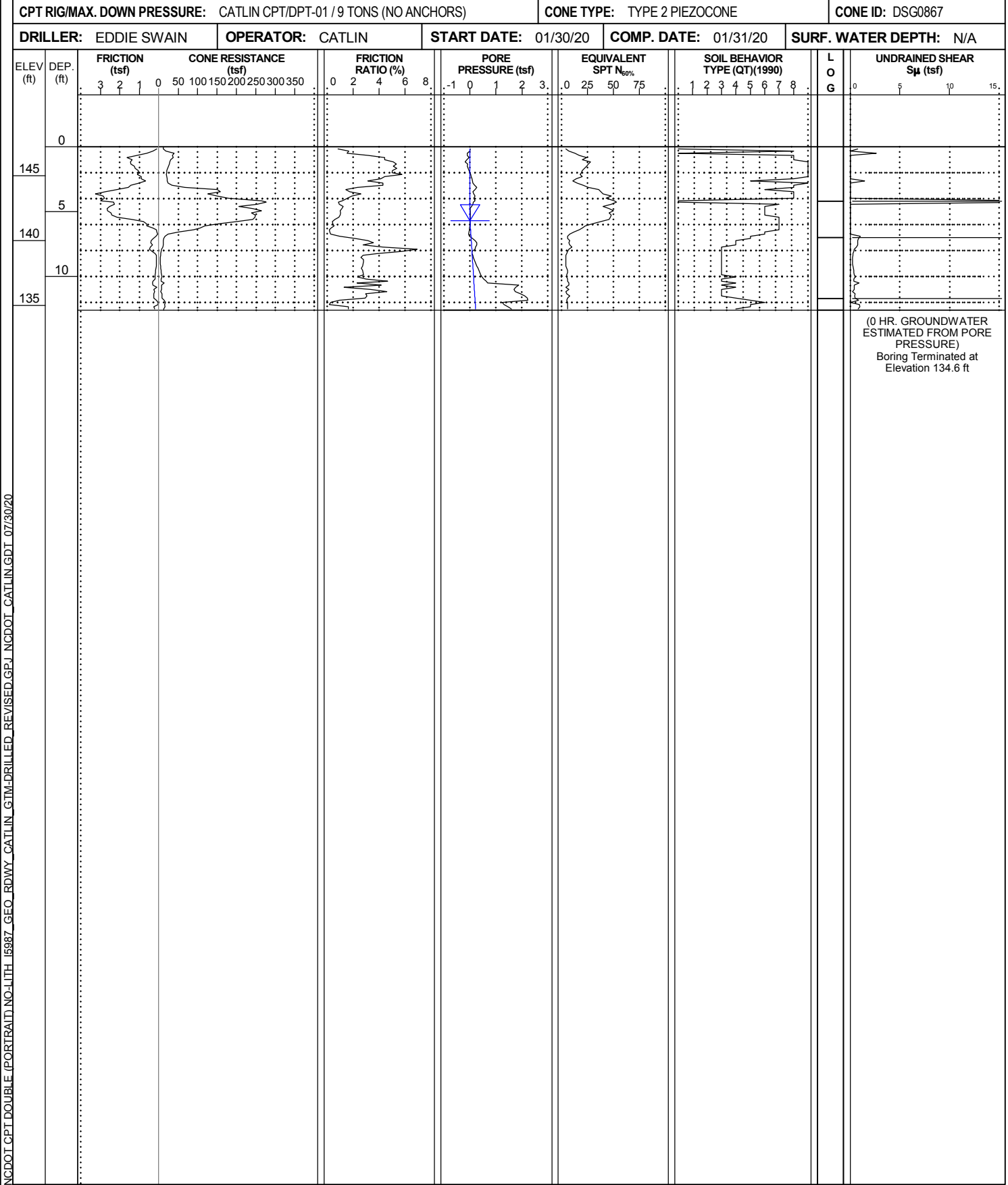

NCDOT CPT DOUBLE (PORTRAIT) NO-LITH 15987_GEO_RDWY_CATLIN_GTM-DRILLED_REVISED.GPJ_NCDOT_CATLIN.GDT_07/30/20

CONE PENETROMETER TEST BORING REPORT



WBS: 47533.1.1	TIP: I-5987A	COUNTY: ROBESON/CUMBERLAND	GEOLOGIST: S. HUDSON
SITE DESCRIPTION: I-95 CUMBERLAND/ROBESON COUNTIES FROM US 301 (EXIT 22) TO I-95 BUSINESS/US 301 (EXIT 40)			GROUND WTR (ft)
BORING NO.: L_37300_RT	STATION: 373+00	OFFSET: 81 ft RT	ALIGNMENT: -L-
COLLAR ELEV.: 146.3 ft	TOTAL DEPTH: 13.5 ft	NORTHING: 362,206	EASTING: 2,000,935
CPT RIG/MAX. DOWN PRESSURE: CATLIN CPT/DPT-01 / 9 TONS (NO ANCHORS)		CONE TYPE: TYPE 2 PIEZOCONE	
DRILLER: EDDIE SWAIN		OPERATOR: CATLIN	
START DATE: 12/18/19		COMP. DATE: 12/18/19	
SURF. WATER DEPTH: N/A		EST. 0 HR. 0.4	
24 HR. N/A		CONE ID: DSA1123	

WBS: 47533.1.1	TIP: I-5987A	COUNTY: ROBESON/CUMBERLAND	GEOLOGIST: S. HUDSON
SITE DESCRIPTION: I-95 CUMBERLAND/ROBESON COUNTIES FROM US 301 (EXIT 22) TO I-95 BUSINESS/US 301 (EXIT 40)			GROUND WTR (ft)
BORING NO.: L_37800_RT	STATION: 378+00	OFFSET: 87 ft RT	ALIGNMENT: -L-
COLLAR ELEV.: 148.1 ft	TOTAL DEPTH: 10.2 ft	NORTHING: 362,706	EASTING: 2,000,945
CPT RIG/MAX. DOWN PRESSURE: CATLIN CPT/DPT-01 / 9 TONS (NO ANCHORS)		CONE TYPE: TYPE 2 PIEZOCONE	
DRILLER: EDDIE SWAIN		OPERATOR: CATLIN	
START DATE: 12/18/19		COMP. DATE: 12/18/19	
SURF. WATER DEPTH: N/A		EST. 0 HR. 0.1	
24 HR. N/A		CONE ID: DSA1123	

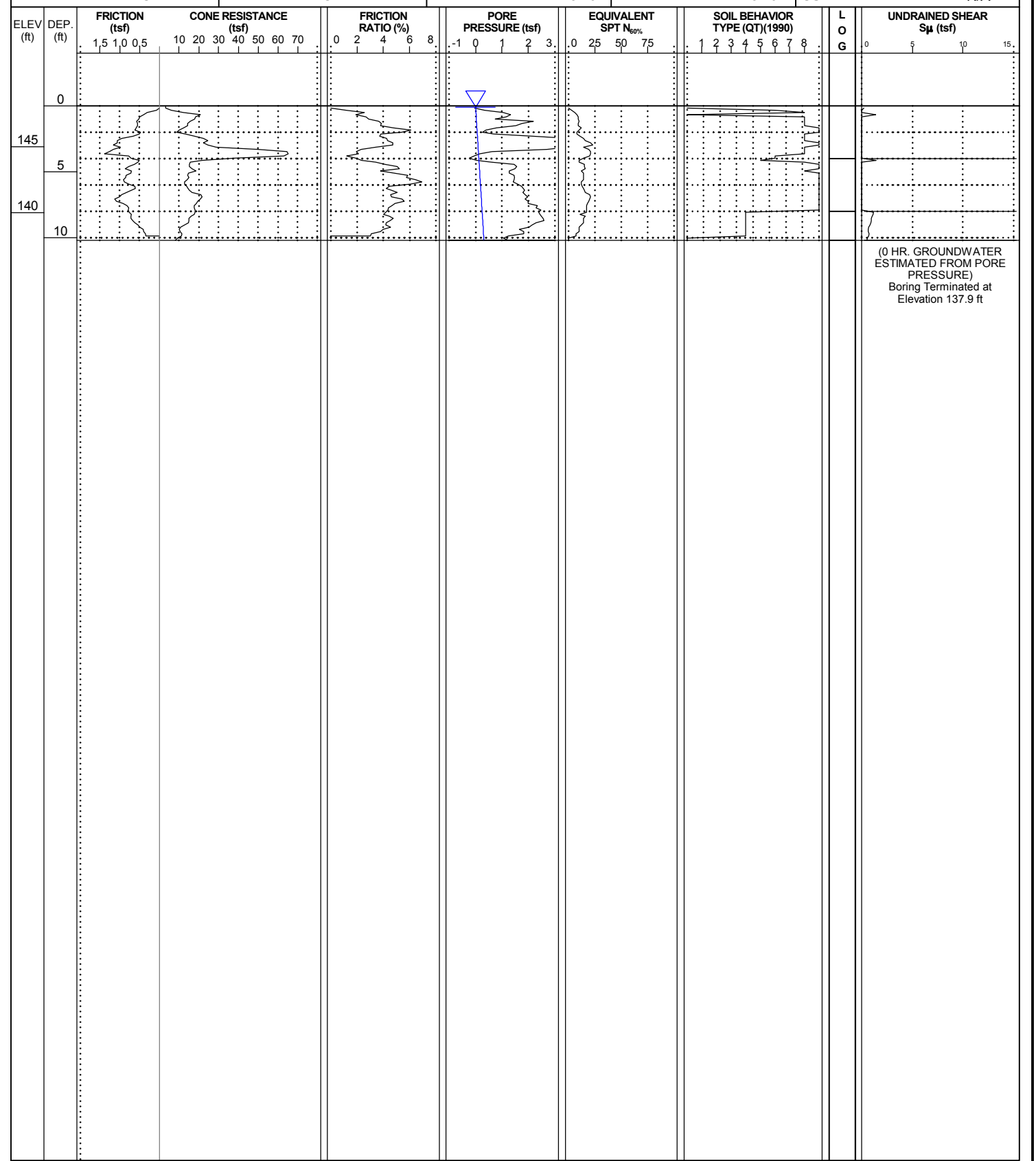
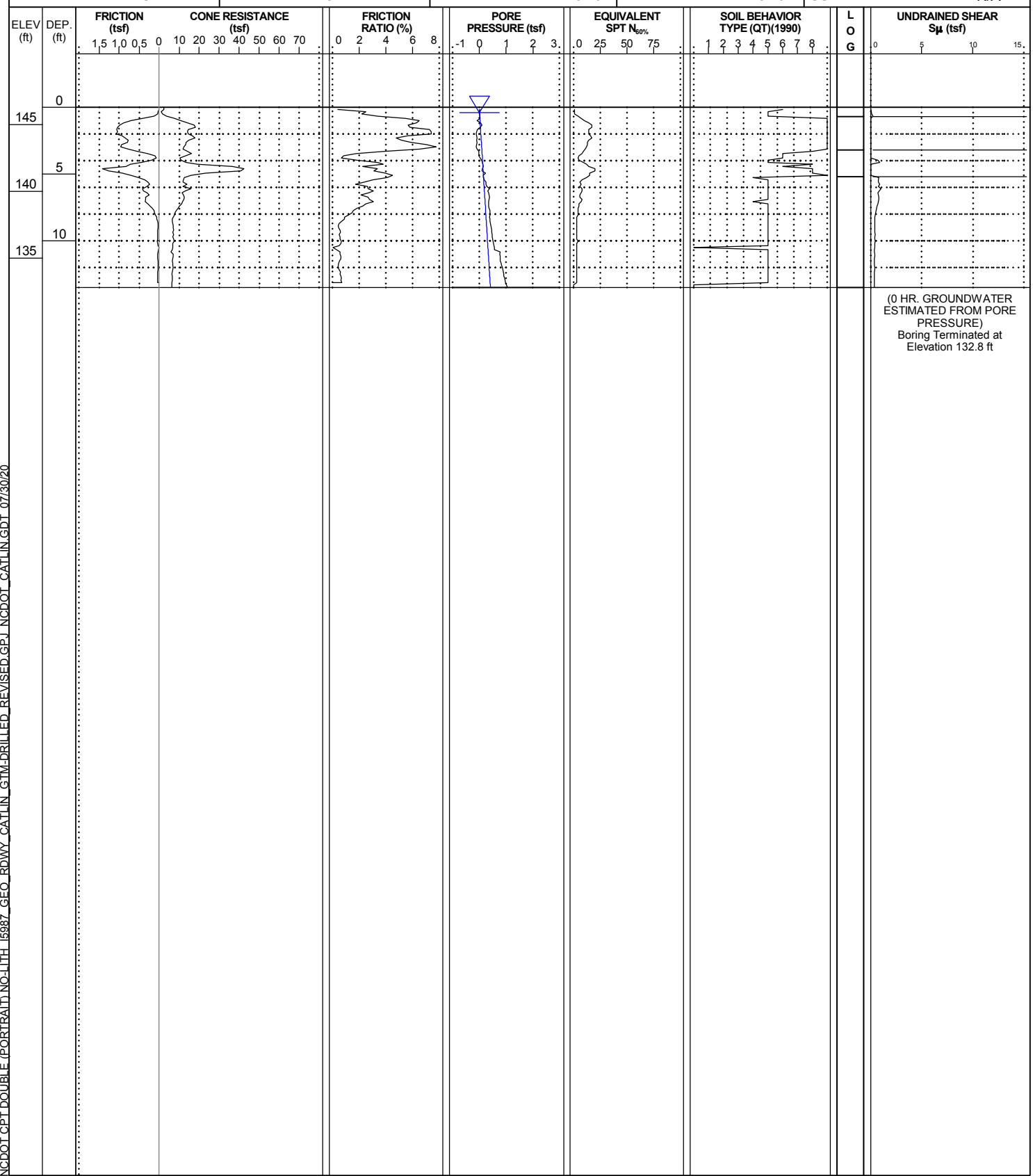

NCDOT CPT DOUBLE (PORTRAIT) NO-LITH 15987_GEO_RDWY_CATLIN_GTM-DRILLED_REVISED.GPJ NCDOT_CATLIN.GDT 07/30/20

CONE PENETROMETER TEST BORING REPORT



WBS: 47533.1.1	TIP: I-5987A	COUNTY: ROBESON/CUMBERLAND	GEOLOGIST: S. HUDSON
SITE DESCRIPTION: I-95 CUMBERLAND/ROBESON COUNTIES FROM US 301 (EXIT 22) TO I-95 BUSINESS/US 301 (EXIT 40)			GROUND WTR (ft)
BORING NO.: L_38300_RT	STATION: 383+00	OFFSET: 81 ft RT	ALIGNMENT: -L-
COLLAR ELEV.: 151.5 ft	TOTAL DEPTH: 9.4 ft	NORTHING: 363,206	EASTING: 2,000,944
CPT RIG/MAX. DOWN PRESSURE: CATLIN CPT/DPT-01 / 9 TONS (NO ANCHORS)		CONE TYPE: TYPE 2 PIEZOcone	CONE ID: DSA1123
DRILLER: EDDIE SWAIN	OPERATOR: CATLIN	START DATE: 12/18/19	COMP. DATE: 12/18/19
EST. 0 HR. 0.3		24 HR. N/A	

WBS: 47533.1.1	TIP: I-5987A	COUNTY: ROBESON/CUMBERLAND	GEOLOGIST: S. HUDSON
SITE DESCRIPTION: I-95 CUMBERLAND/ROBESON COUNTIES FROM US 301 (EXIT 22) TO I-95 BUSINESS/US 301 (EXIT 40)			GROUND WTR (ft)
BORING NO.: L_38800_RT	STATION: 388+00	OFFSET: 86 ft RT	ALIGNMENT: -L-
COLLAR ELEV.: 152.2 ft	TOTAL DEPTH: 12.5 ft	NORTHING: 363,706	EASTING: 2,000,953
CPT RIG/MAX. DOWN PRESSURE: CATLIN CPT/DPT-01 / 9 TONS (NO ANCHORS)		CONE TYPE: TYPE 2 PIEZOcone	CONE ID: DSA1123
DRILLER: EDDIE SWAIN	OPERATOR: CATLIN	START DATE: 12/18/19	COMP. DATE: 12/18/19
EST. 0 HR. 2.8		24 HR. N/A	

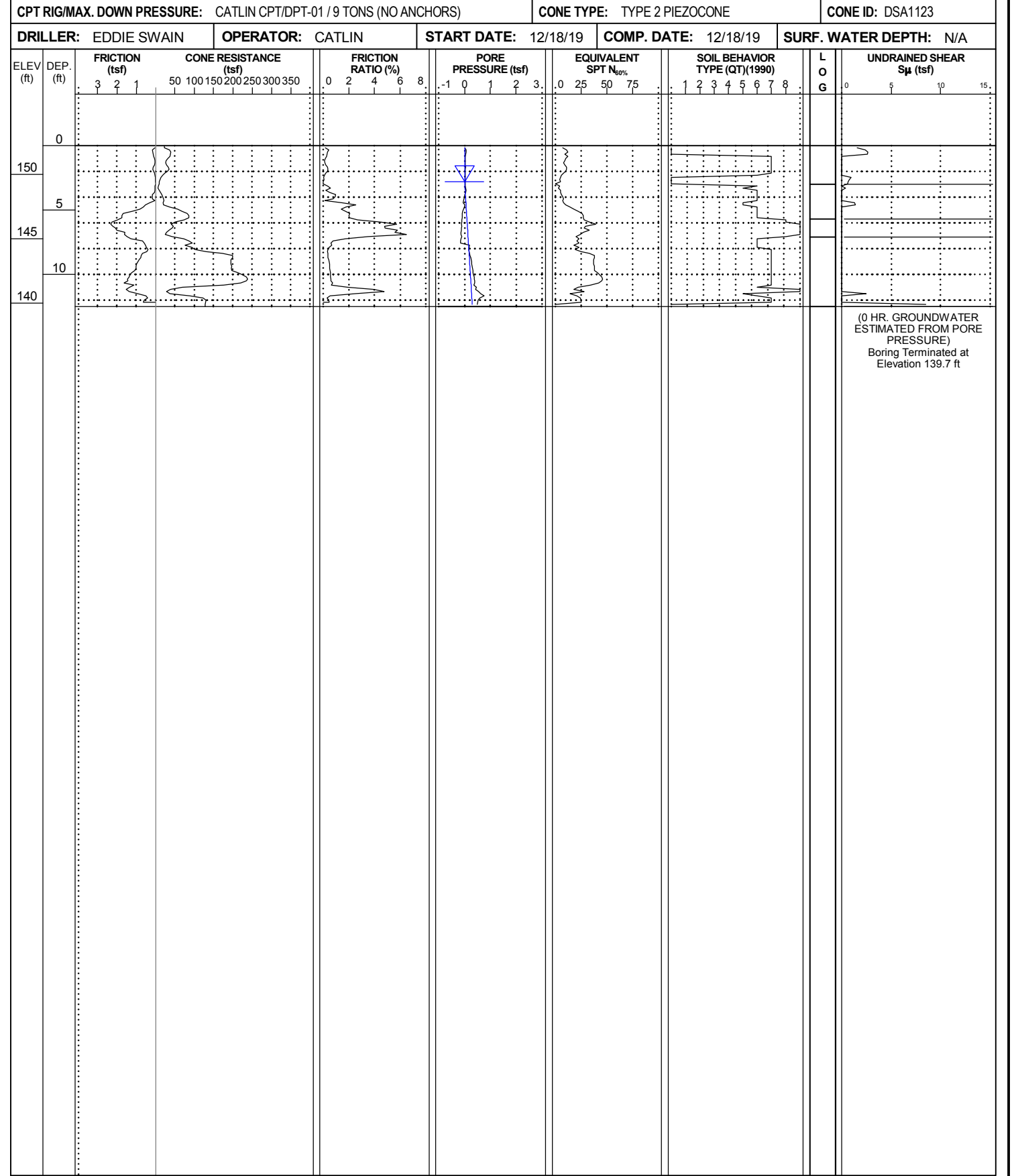
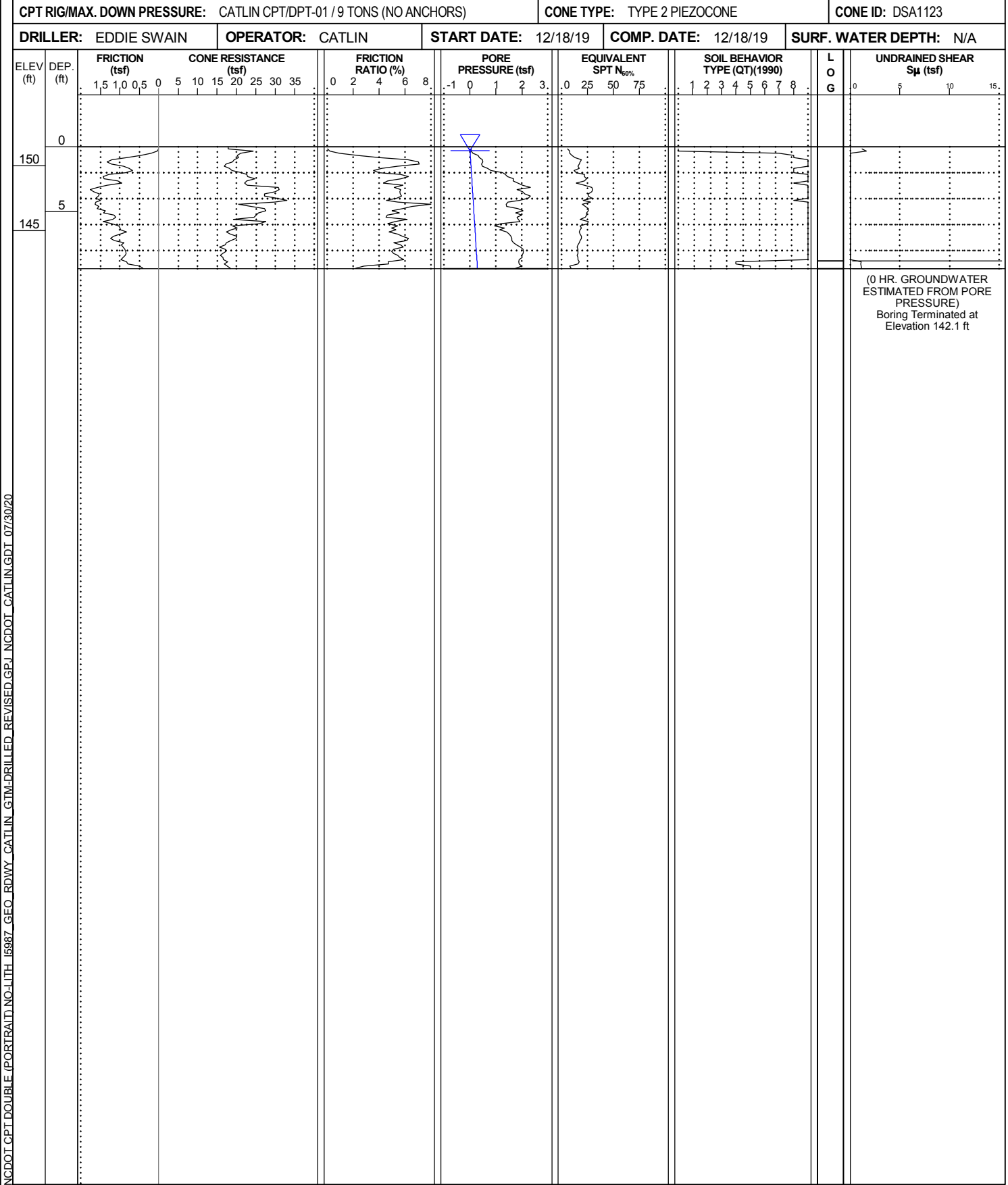

NCDOI CPT DOUBLE (PORTRAIT) NO-LITH 15987_GEO_ROWY_CATLIN_GTM-DRILLED_REVISED.GPJ_NCDOT_CATLIN.GDT_07/30/20

CONE PENETROMETER TEST BORING REPORT



WBS: 47533.1.1	TIP: I-5987A	COUNTY: ROBESON/CUMBERLAND	GEOLOGIST: S. HUDSON
SITE DESCRIPTION: I-95 CUMBERLAND/ROBESON COUNTIES FROM US 301 (EXIT 22) TO I-95 BUSINESS/US 301 (EXIT 40)			GROUND WTR (ft)
BORING NO.: L_39300_RT	STATION: 393+00	OFFSET: 82 ft RT	ALIGNMENT: -L-
COLLAR ELEV.: 151.4 ft	TOTAL DEPTH: 12.4 ft	NORTHING: 364,206	EASTING: 2,000,953
CPT RIG/MAX. DOWN PRESSURE: CATLIN CPT/DPT-01 / 9 TONS (NO ANCHORS)		CONE TYPE: TYPE 2 PIEZOCONE	CONE ID: DSA1123
DRILLER: EDDIE SWAIN	OPERATOR: CATLIN	START DATE: 12/18/19	COMP. DATE: 12/18/19
EST. 0 HR. 3.0		24 HR. N/A	

WBS: 47533.1.1	TIP: I-5987A	COUNTY: ROBESON/CUMBERLAND	GEOLOGIST: S. HUDSON
SITE DESCRIPTION: I-95 CUMBERLAND/ROBESON COUNTIES FROM US 301 (EXIT 22) TO I-95 BUSINESS/US 301 (EXIT 40)			GROUND WTR (ft)
BORING NO.: L_39800_RT	STATION: 398+00	OFFSET: 81 ft RT	ALIGNMENT: -L-
COLLAR ELEV.: 152.4 ft	TOTAL DEPTH: 12.4 ft	NORTHING: 364,706	EASTING: 2,000,957
CPT RIG/MAX. DOWN PRESSURE: CATLIN CPT/DPT-01 / 9 TONS (NO ANCHORS)		CONE TYPE: TYPE 2 PIEZOCONE	CONE ID: DSA1123
DRILLER: EDDIE SWAIN	OPERATOR: CATLIN	START DATE: 12/18/19	COMP. DATE: 12/18/19
EST. 0 HR. 5.9		24 HR. N/A	

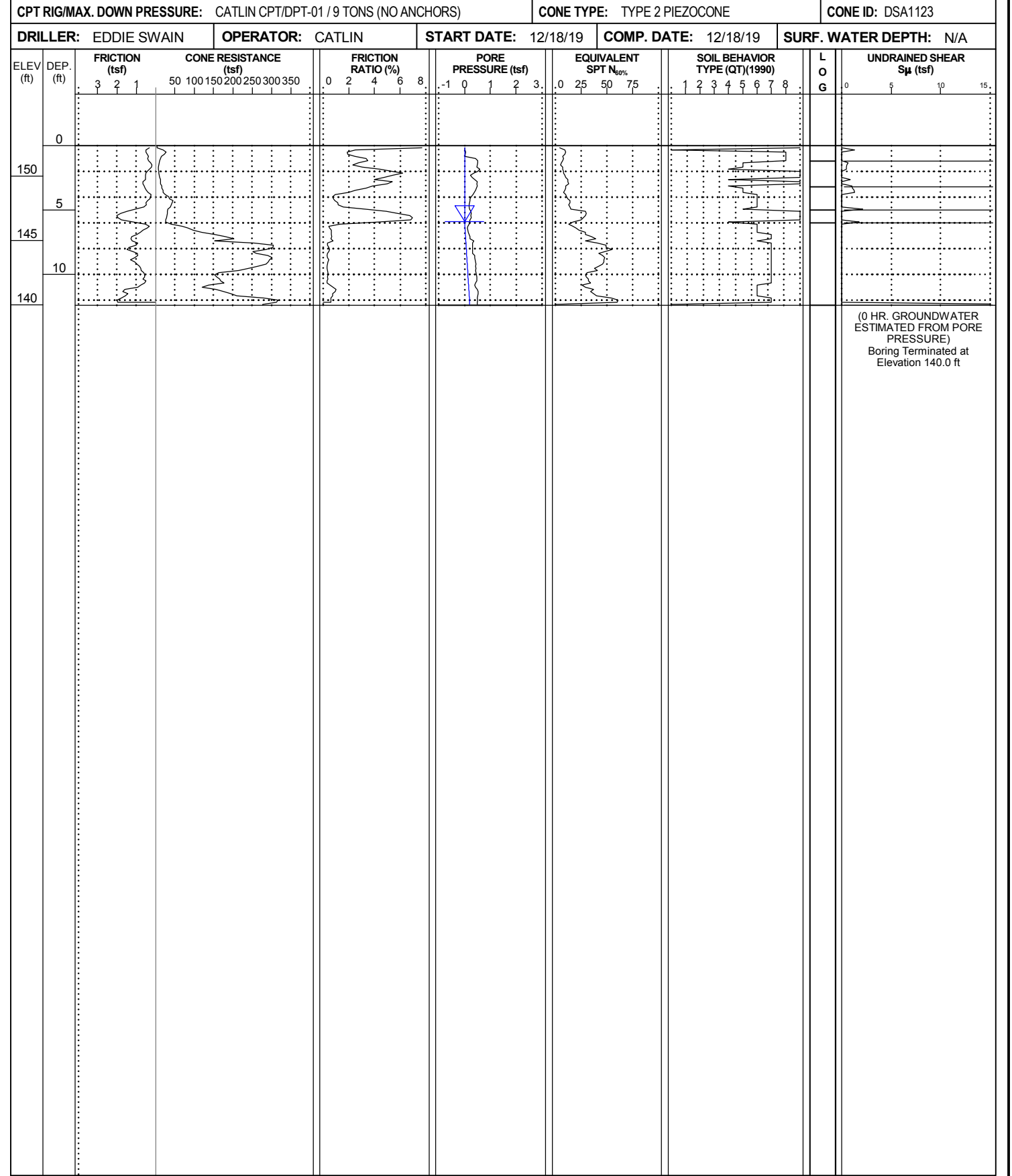
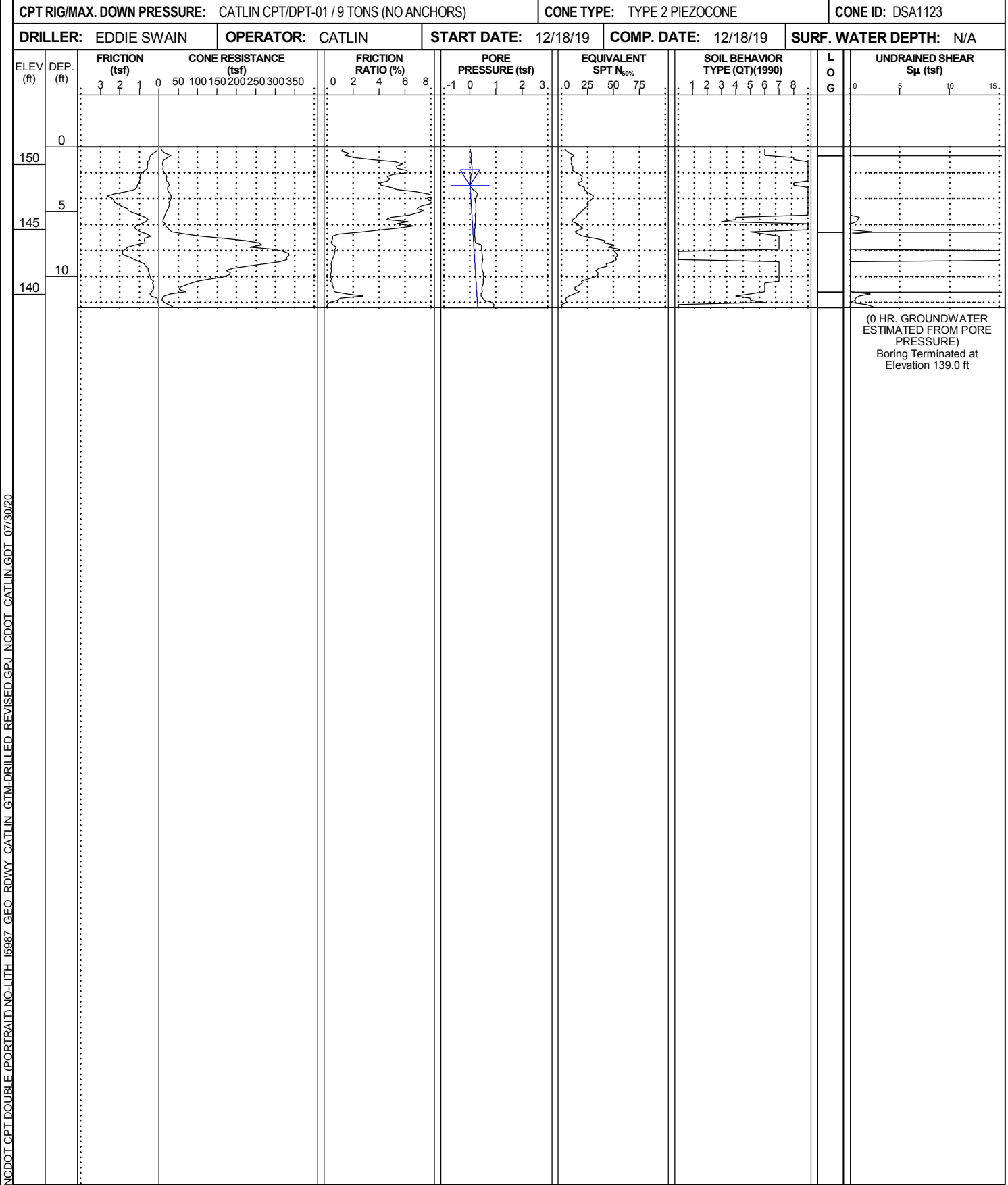

NCDOT CPT DOUBLE (PORTRAIT) NO-LITH 15987_GEO_RDWY_CATLIN_GTM-DRILLED_REVISED.GPJ_NCDOT_CATLIN.GDT_07/30/20

CONE PENETROMETER TEST BORING REPORT



WBS: 47533.1.1	TIP: I-5987A	COUNTY: ROBESON/CUMBERLAND	GEOLOGIST: S. HUDSON
SITE DESCRIPTION: I-95 CUMBERLAND/ROBESON COUNTIES FROM US 301 (EXIT 22) TO I-95 BUSINESS/US 301 (EXIT 40)			GROUND WTR (ft)
BORING NO.: L_40200_RT	STATION: 402+00	OFFSET: 92 ft RT	ALIGNMENT: -L-
COLLAR ELEV.: 153.2 ft	TOTAL DEPTH: 14.3 ft	NORTHING: 365,106	EASTING: 2,000,971
CPT RIG/MAX. DOWN PRESSURE: CATLIN CPT/DPT-01 / 9 TONS (NO ANCHORS)		CONE TYPE: TYPE 2 PIEZOCONE	CONE ID: DSA1123
DRILLER: EDDIE SWAIN	OPERATOR: CATLIN	START DATE: 12/18/19	COMP. DATE: 12/18/19
		SURF. WATER DEPTH: N/A	

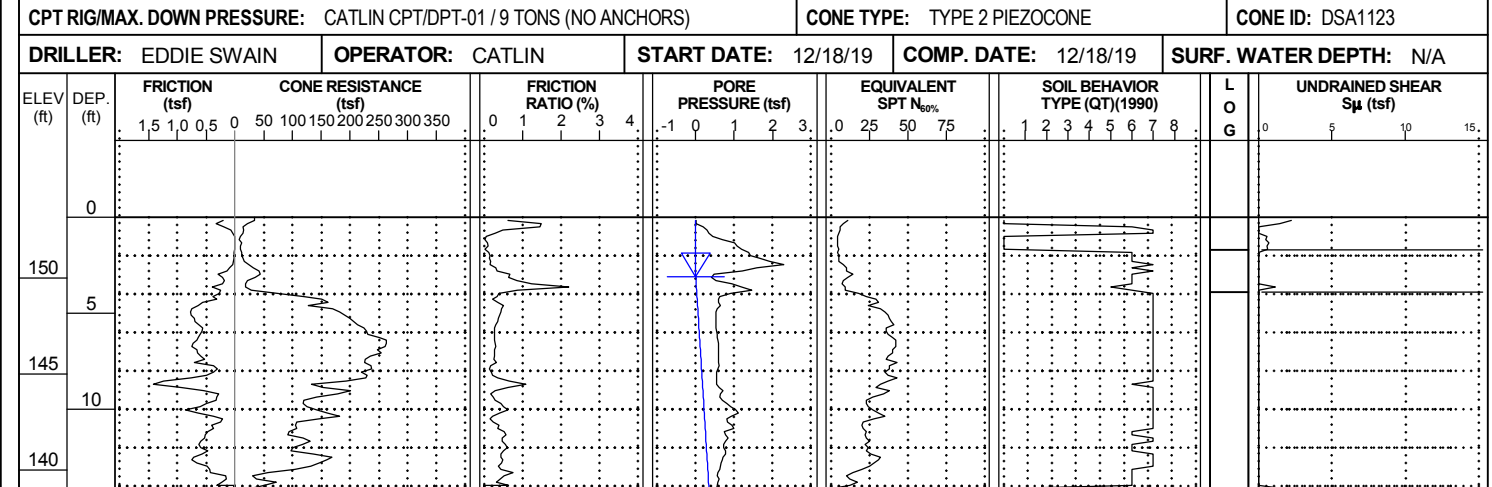

(0 HR. GROUNDWATER ESTIMATED FROM PORE PRESSURE)
Boring Terminated at Elevation 138.9 ft

WBS: 47533.1.1	TIP: I-5987A	COUNTY: ROBESON/CUMBERLAND	GEOLOGIST: S. HUDSON
SITE DESCRIPTION: I-95 CUMBERLAND/ROBESON COUNTIES FROM US 301 (EXIT 22) TO I-95 BUSINESS/US 301 (EXIT 40)			GROUND WTR (ft)
BORING NO.: L_40700_LT	STATION: 407+00	OFFSET: 91 ft LT	ALIGNMENT: -L-
COLLAR ELEV.: 159.8 ft	TOTAL DEPTH: 10.1 ft	NORTHING: 365,608	EASTING: 2,000,792
CPT RIG/MAX. DOWN PRESSURE: CATLIN CPT/DPT-01 / 9 TONS (NO ANCHORS)		CONE TYPE: TYPE 2 PIEZOCONE	CONE ID: DSG0867
DRILLER: EDDIE SWAIN	OPERATOR: CATLIN	START DATE: 01/30/20	COMP. DATE: 01/30/20
		SURF. WATER DEPTH: N/A	

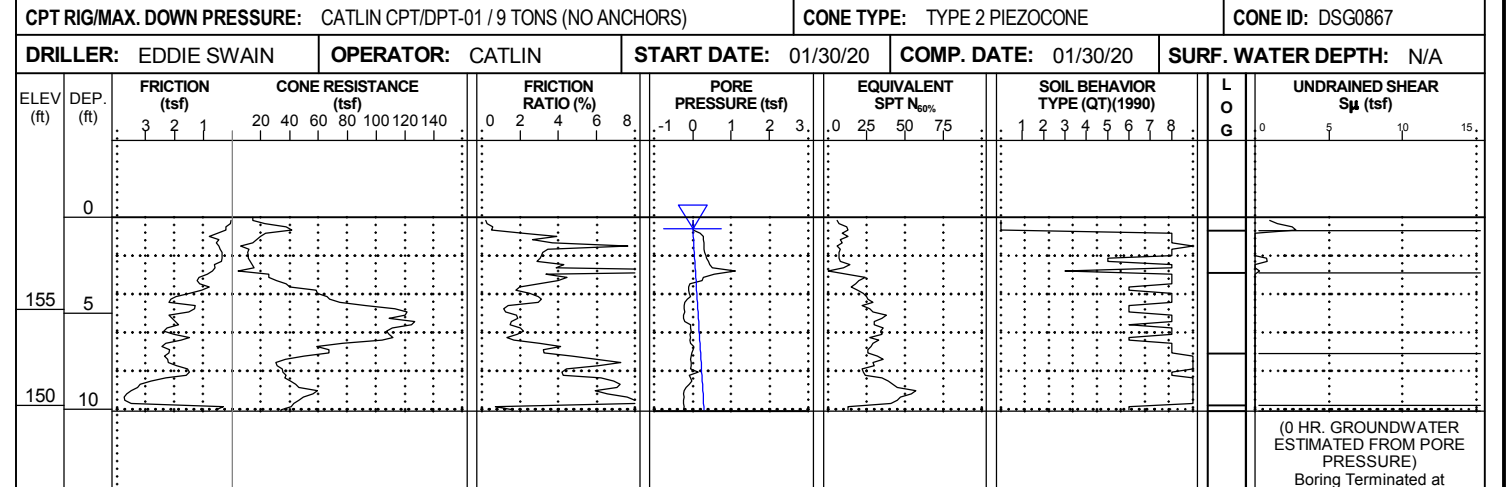

(0 HR. GROUNDWATER ESTIMATED FROM PORE PRESSURE)
Boring Terminated at Elevation 149.7 ft

NCDOT CPT DOUBLE (PORTRAIT) NO-LITH 15987_GEO_ROWY_CATLIN_GTM-DRILLED_REVISED.GPJ_NCDOT_CATLIN.GDT_07/30/20

CONE PENETROMETER TEST BORING REPORT



WBS: 47533.1.1	TIP: I-5987A	COUNTY: ROBESON/CUMBERLAND	GEOLOGIST: S. HUDSON
SITE DESCRIPTION: I-95 CUMBERLAND/ROBESON COUNTIES FROM US 301 (EXIT 22) TO I-95 BUSINESS/US 301 (EXIT 40)			GROUND WTR (ft)
BORING NO.: L_41200_LT	STATION: 412+00	OFFSET: 75 ft LT	ALIGNMENT: -L-
COLLAR ELEV.: 158.5 ft	TOTAL DEPTH: 10.5 ft	NORTHING: 366,107	EASTING: 2,000,813
CPT RIG/MAX. DOWN PRESSURE: CATLIN CPT/DPT-01 / 9 TONS (NO ANCHORS)		CONE TYPE: TYPE 2 PIEZOCONE	CONE ID: DSG0867
DRILLER: EDDIE SWAIN	OPERATOR: CATLIN	START DATE: 01/30/20	COMP. DATE: 01/30/20
		SURF. WATER DEPTH: N/A	

WBS: 47533.1.1	TIP: I-5987A	COUNTY: ROBESON/CUMBERLAND	GEOLOGIST: S. HUDSON
SITE DESCRIPTION: I-95 CUMBERLAND/ROBESON COUNTIES FROM US 301 (EXIT 22) TO I-95 BUSINESS/US 301 (EXIT 40)			GROUND WTR (ft)
BORING NO.: L_41700_LT	STATION: 417+00	OFFSET: 73 ft LT	ALIGNMENT: -L-
COLLAR ELEV.: 157.1 ft	TOTAL DEPTH: 10.4 ft	NORTHING: 366,607	EASTING: 2,000,819
CPT RIG/MAX. DOWN PRESSURE: CATLIN CPT/DPT-01 / 9 TONS (NO ANCHORS)		CONE TYPE: TYPE 2 PIEZOCONE	CONE ID: DSG0867
DRILLER: EDDIE SWAIN	OPERATOR: CATLIN	START DATE: 01/30/20	COMP. DATE: 01/31/20
		SURF. WATER DEPTH: N/A	

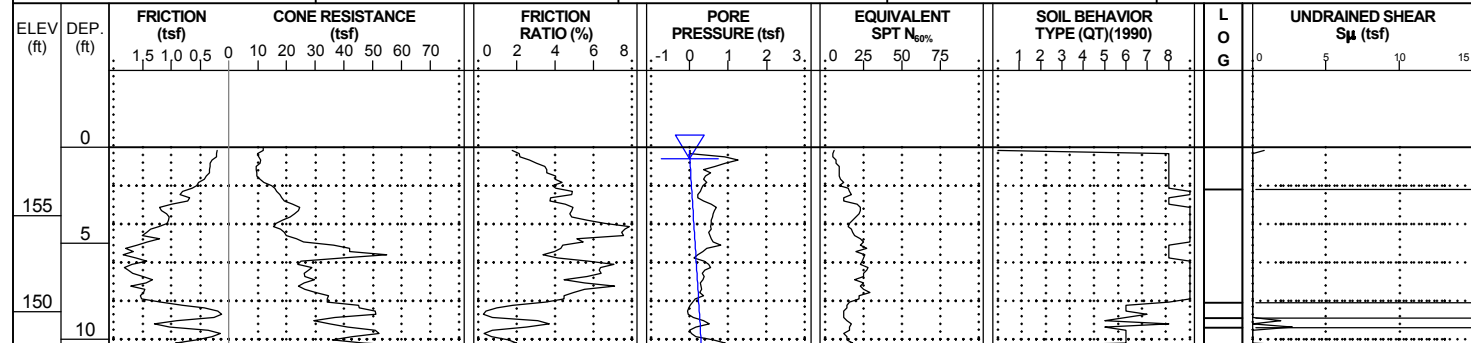

(0 HR. GROUNDWATER ESTIMATED FROM PORE PRESSURE)
Boring Terminated at Elevation 148.0 ft

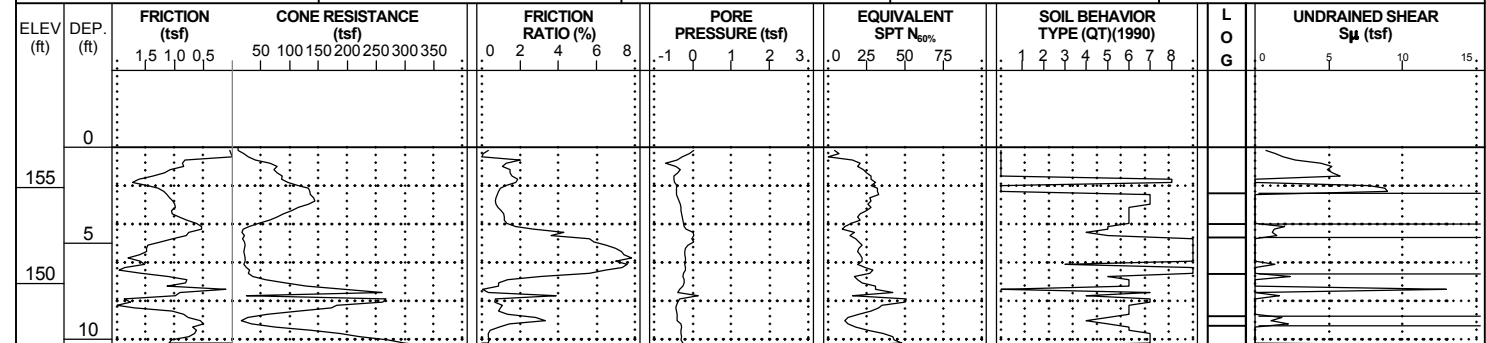

(0 HR. GROUNDWATER ESTIMATED FROM PORE PRESSURE)
Boring Terminated at Elevation 146.7 ft

PORE PRESSURE NOT CONDUSIVE TO ESTIMATING GROUND WATER - EST. GROUNDWATER SUSPECT

NCDOT CPT DOUBLE (PORTRAIT) NO-LITH 15987_GEO_ROWY_CATLIN_GTM-DRILLED_REVISED.GPJ NCDOT_CATLIN.GDT 07/30/20

CONE PENETROMETER TEST BORING REPORT



WBS: 47533.1.1	TIP: I-5987A	COUNTY: ROBESON/CUMBERLAND	GEOLOGIST: S. HUDSON
SITE DESCRIPTION: I-95 CUMBERLAND/ROBESON COUNTIES FROM US 301 (EXIT 22) TO I-95 BUSINESS/US 301 (EXIT 40)			GROUND WTR (ft)
BORING NO.: L_42200_LT	STATION: 422+00	OFFSET: 88 ft LT	ALIGNMENT: -L-
COLLAR ELEV.: 158.0 ft	TOTAL DEPTH: 12.4 ft	NORTHING: 367,107	EASTING: 2,000,808
CPT RIG/MAX. DOWN PRESSURE: CATLIN CPT/DPT-01 / 9 TONS (NO ANCHORS)		CONE TYPE: TYPE 2 PIEZOCONE	
DRILLER: EDDIE SWAIN		OPERATOR: CATLIN	
START DATE: 01/30/20		COMP. DATE: 01/31/20	
SURF. WATER DEPTH: N/A		EST. 0 HR. 10.9	
24 HR. N/A			

WBS: 47533.1.1	TIP: I-5987A	COUNTY: ROBESON/CUMBERLAND	GEOLOGIST: S. HUDSON
SITE DESCRIPTION: I-95 CUMBERLAND/ROBESON COUNTIES FROM US 301 (EXIT 22) TO I-95 BUSINESS/US 301 (EXIT 40)			GROUND WTR (ft)
BORING NO.: L_42700_LT	STATION: 427+00	OFFSET: 89 ft LT	ALIGNMENT: -L-
COLLAR ELEV.: 157.5 ft	TOTAL DEPTH: 10.5 ft	NORTHING: 367,609	EASTING: 2,000,816
CPT RIG/MAX. DOWN PRESSURE: CATLIN CPT/DPT-01 / 9 TONS (NO ANCHORS)		CONE TYPE: TYPE 2 PIEZOCONE	
DRILLER: EDDIE SWAIN		OPERATOR: CATLIN	
START DATE: 01/30/20		COMP. DATE: 01/30/20	
SURF. WATER DEPTH: N/A		EST. 0 HR. 5.3	
24 HR. N/A			

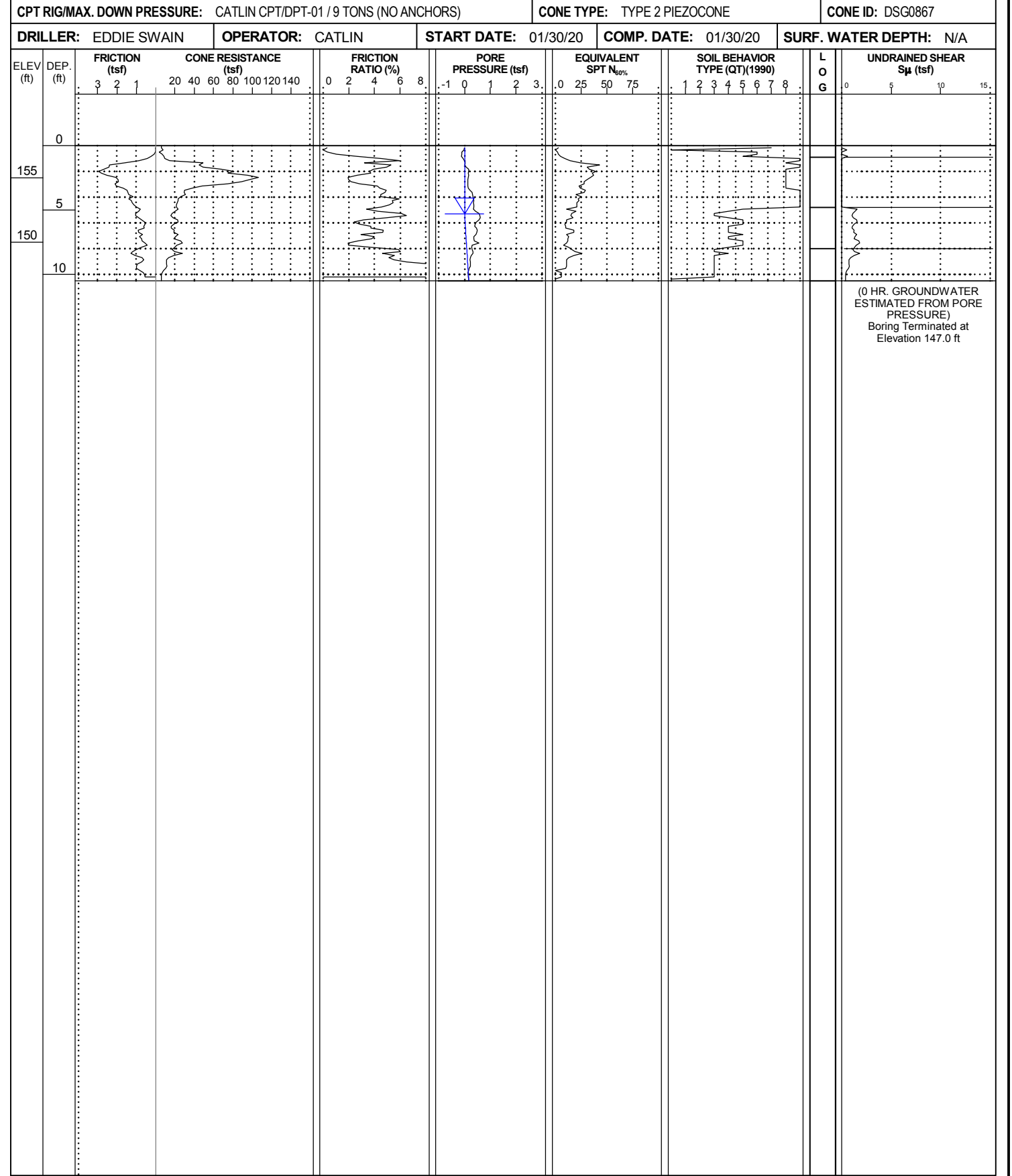
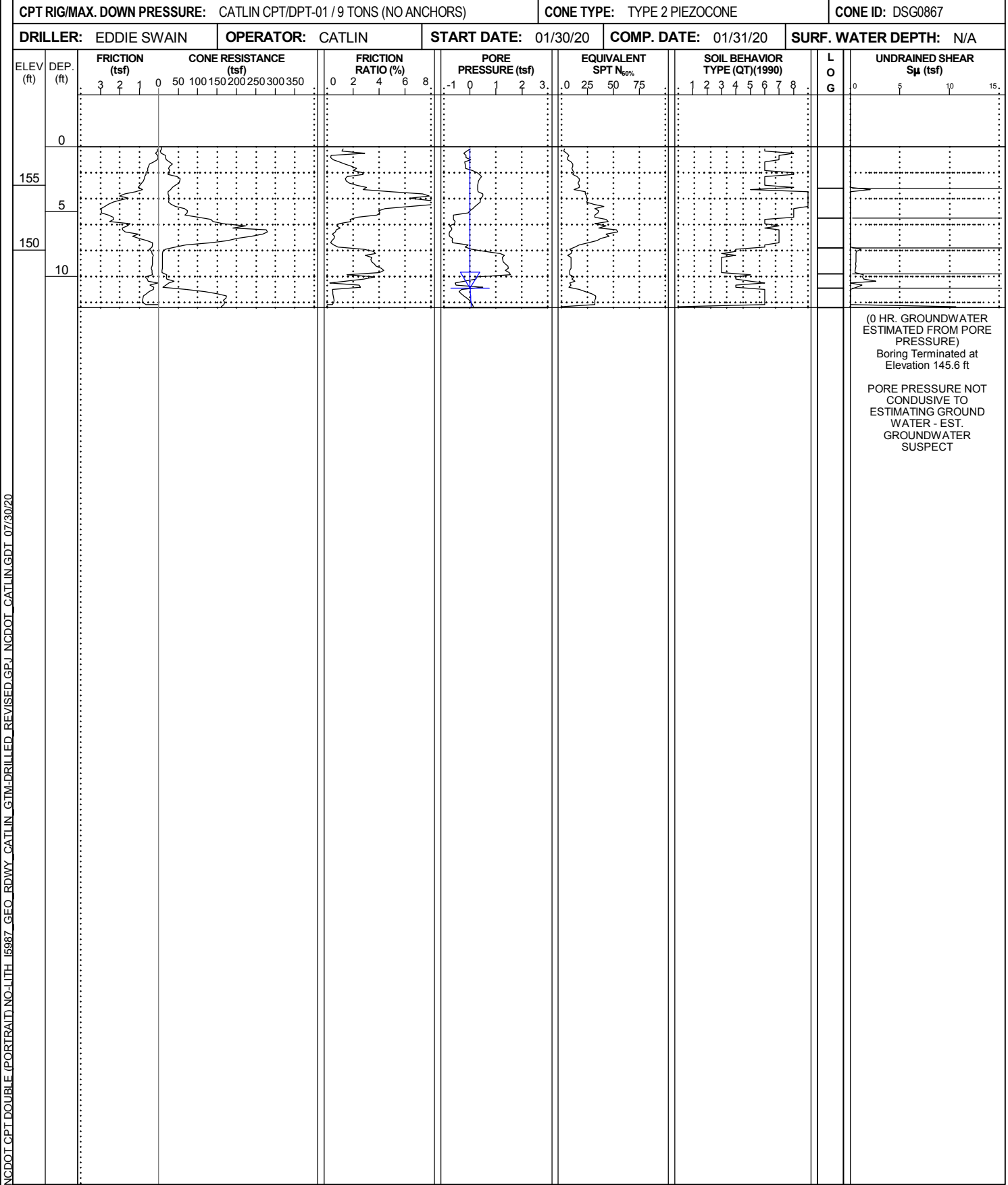

NCDOT CPT DOUBLE (PORTRAIT) NO-LITH 15987_GEO_ROWY_CATLIN_GTM-DRILLED_REVISED.GPJ NCDOT_CATLIN.GDT_07/30/20

CONE PENETROMETER TEST BORING REPORT



WBS: 47533.1.1	TIP: I-5987A	COUNTY: ROBESON/CUMBERLAND	GEOLOGIST: S. HUDSON
SITE DESCRIPTION: I-95 CUMBERLAND/ROBESON COUNTIES FROM US 301 (EXIT 22) TO I-95 BUSINESS/US 301 (EXIT 40)			GROUND WTR (ft)
BORING NO.: L_43200_LT	STATION: 432+00	OFFSET: 90 ft LT	ALIGNMENT: -L-
COLLAR ELEV.: 159.1 ft	TOTAL DEPTH: 10.4 ft	NORTHING: 368,110	EASTING: 2,000,833
CPT RIG/MAX. DOWN PRESSURE: CATLIN CPT/DPT-01 / 9 TONS (NO ANCHORS)		CONE TYPE: TYPE 2 PIEZOcone	
DRILLER: EDDIE SWAIN		OPERATOR: CATLIN	
START DATE: 01/30/20		COMP. DATE: 01/31/20	
SURF. WATER DEPTH: N/A			

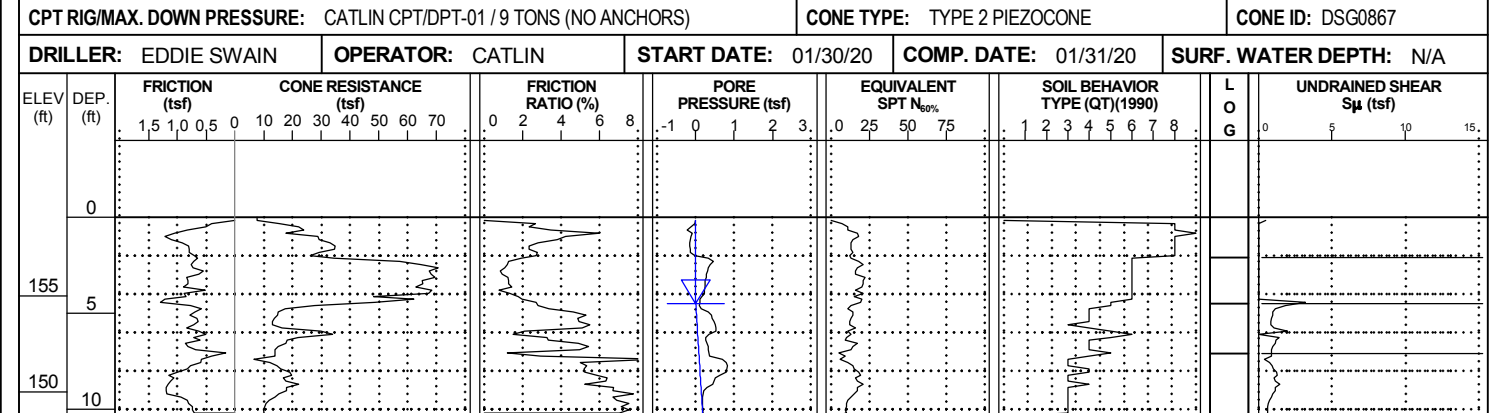

(0 HR. GROUNDWATER ESTIMATED FROM PORE PRESSURE)
Boring Terminated at Elevation 148.7 ft

WBS: 47533.1.1	TIP: I-5987A	COUNTY: ROBESON/CUMBERLAND	GEOLOGIST: S. HUDSON
SITE DESCRIPTION: I-95 CUMBERLAND/ROBESON COUNTIES FROM US 301 (EXIT 22) TO I-95 BUSINESS/US 301 (EXIT 40)			GROUND WTR (ft)
BORING NO.: L_43700_LT	STATION: 437+00	OFFSET: 89 ft LT	ALIGNMENT: -L-
COLLAR ELEV.: 160.4 ft	TOTAL DEPTH: 10.3 ft	NORTHING: 368,611	EASTING: 2,000,861
CPT RIG/MAX. DOWN PRESSURE: CATLIN CPT/DPT-01 / 9 TONS (NO ANCHORS)		CONE TYPE: TYPE 2 PIEZOcone	
DRILLER: EDDIE SWAIN		OPERATOR: CATLIN	
START DATE: 01/30/20		COMP. DATE: 01/31/20	
SURF. WATER DEPTH: N/A			

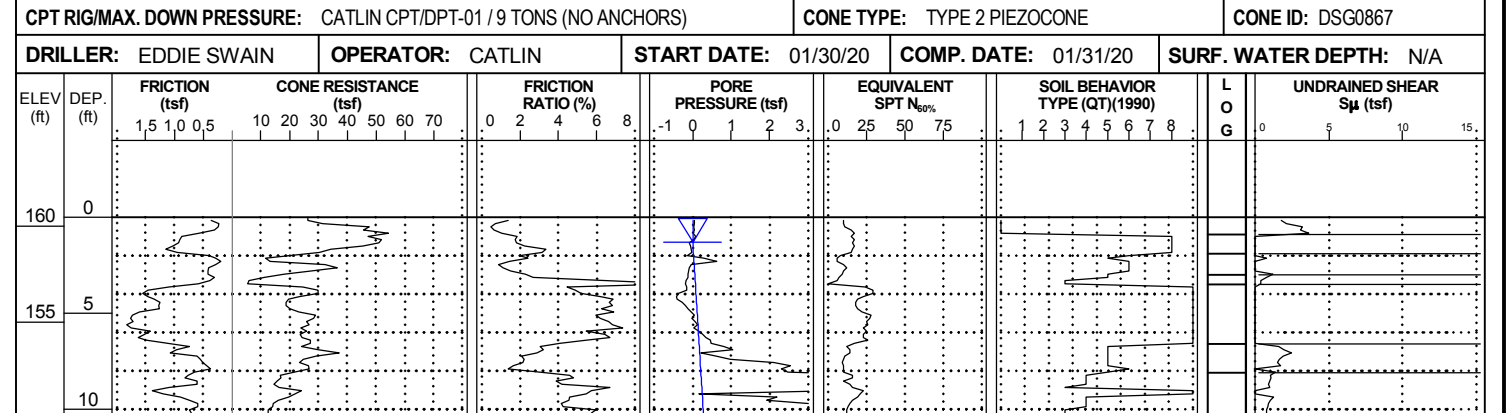

(0 HR. GROUNDWATER ESTIMATED FROM PORE PRESSURE)
Boring Terminated at Elevation 150.1 ft

NCDOT CPT DOUBLE (PORTRAIT) NO-LITH 15987_GEO_ROWY_CATLIN_GTM-DRILLED_REVISED.GPJ NCDOT_CATLIN.GDT 07/30/20

CONE PENETROMETER TEST BORING REPORT



WBS: 47533.1.1	TIP: I-5987A	COUNTY: ROBESON/CUMBERLAND	GEOLOGIST: S. HUDSON
SITE DESCRIPTION: I-95 CUMBERLAND/ROBESON COUNTIES FROM US 301 (EXIT 22) TO I-95 BUSINESS/US 301 (EXIT 40)			GROUND WTR (ft)
BORING NO.: L_44200_RT	STATION: 442+00	OFFSET: 91 ft RT	ALIGNMENT: -L-
COLLAR ELEV.: 160.6 ft	TOTAL DEPTH: 10.2 ft	NORTHING: 369,098	EASTING: 2,001,075
CPT RIG/MAX. DOWN PRESSURE: CATLIN CPT/DPT-01 / 9 TONS (NO ANCHORS)		CONE TYPE: TYPE 2 PIEZOCONE	CONE ID: DSA1123
DRILLER: EDDIE SWAIN	OPERATOR: CATLIN	START DATE: 12/18/19	COMP. DATE: 12/18/19
		SURF. WATER DEPTH: N/A	

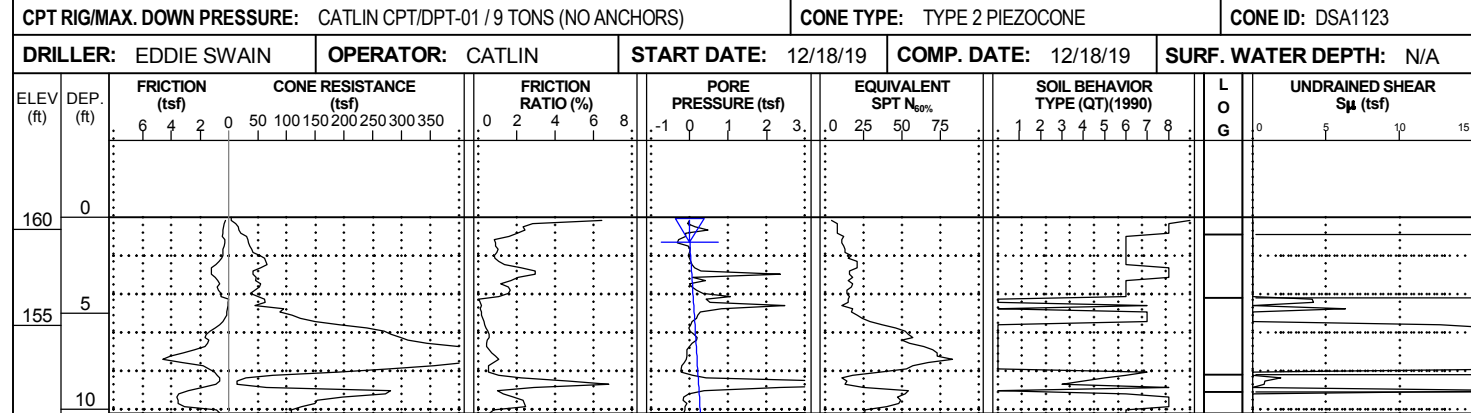

(0 HR. GROUNDWATER ESTIMATED FROM PORE PRESSURE)
Boring Terminated at Elevation 150.4 ft

WBS: 47533.1.1	TIP: I-5987A	COUNTY: ROBESON/CUMBERLAND	GEOLOGIST: S. HUDSON
SITE DESCRIPTION: I-95 CUMBERLAND/ROBESON COUNTIES FROM US 301 (EXIT 22) TO I-95 BUSINESS/US 301 (EXIT 40)			GROUND WTR (ft)
BORING NO.: L_44700_RT	STATION: 447+00	OFFSET: 92 ft RT	ALIGNMENT: -L-
COLLAR ELEV.: 160.7 ft	TOTAL DEPTH: 8.9 ft	NORTHING: 369,597	EASTING: 2,001,111
CPT RIG/MAX. DOWN PRESSURE: CATLIN CPT/DPT-01 / 9 TONS (NO ANCHORS)		CONE TYPE: TYPE 2 PIEZOCONE	CONE ID: DSA1123
DRILLER: EDDIE SWAIN	OPERATOR: CATLIN	START DATE: 12/18/19	COMP. DATE: 12/18/19
		SURF. WATER DEPTH: N/A	

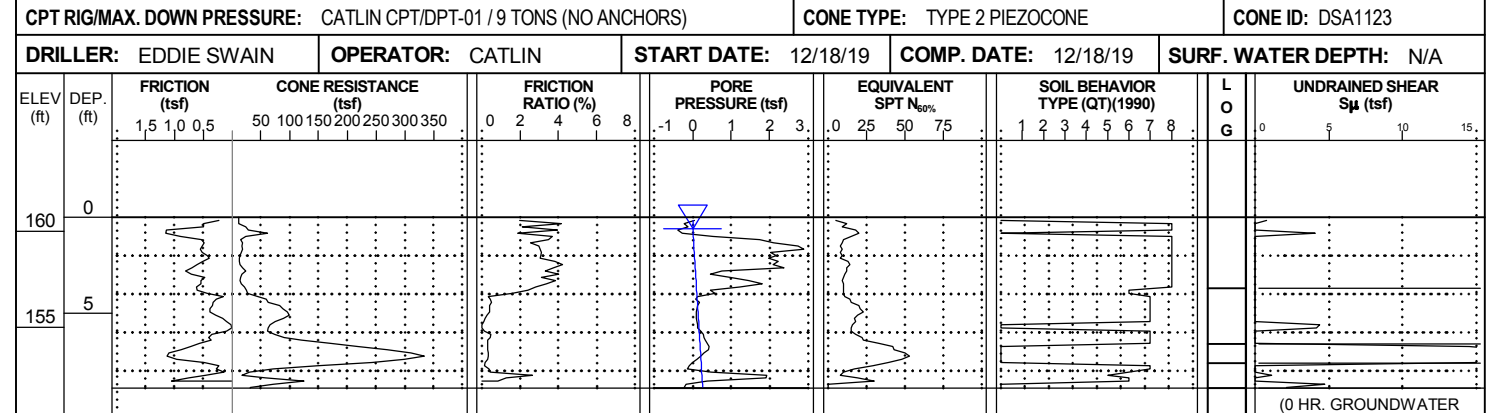

(0 HR. GROUNDWATER ESTIMATED FROM PORE PRESSURE)
Boring Terminated at Elevation 151.8 ft

NCDOT CPT DOUBLE (PORTRAIT) NO-LITH 15987_GEO_RDWY_CATLIN_GTM-DRILLED_REVISED.GPJ NCDOT_CATLIN.GDT_07/30/20

CONE PENETROMETER TEST BORING REPORT



WBS: 47533.1.1	TIP: I-5987A	COUNTY: ROBESON/CUMBERLAND	GEOLOGIST: S. HUDSON
SITE DESCRIPTION: I-95 CUMBERLAND/ROBESON COUNTIES FROM US 301 (EXIT 22) TO I-95 BUSINESS/US 301 (EXIT 40)			GROUND WTR (ft)
BORING NO.: L_46700	STATION: 467+00	OFFSET: 2 ft RT	ALIGNMENT: -L-
COLLAR ELEV.: 165.3 ft	TOTAL DEPTH: 8.3 ft	NORTHING: 371,598	EASTING: 2,001,162
CPT RIG/MAX. DOWN PRESSURE: CATLIN CPT/DPT-01 / 9 TONS (NO ANCHORS)		CONE TYPE: TYPE 2 PIEZOCONE	CONE ID: DSG0867
DRILLER: EDDIE SWAIN	OPERATOR: CATLIN	START DATE: 01/29/20	COMP. DATE: 01/29/20
		SURF. WATER DEPTH: N/A	

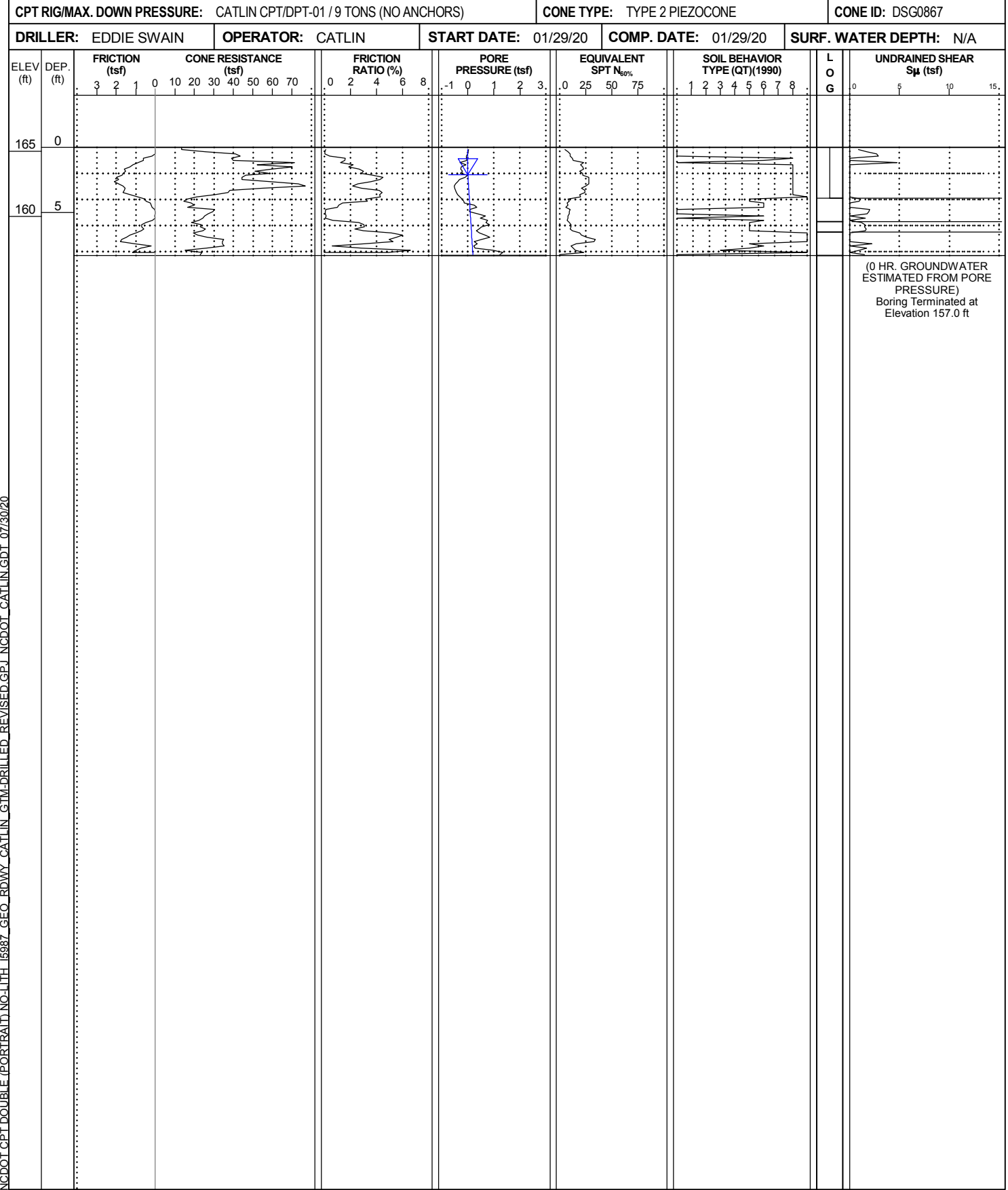

WBS: 47533.1.1	TIP: I-5987A	COUNTY: ROBESON/CUMBERLAND	GEOLOGIST: S. HUDSON
SITE DESCRIPTION: I-95 CUMBERLAND/ROBESON COUNTIES FROM US 301 (EXIT 22) TO I-95 BUSINESS/US 301 (EXIT 40)			GROUND WTR (ft)
BORING NO.: L_47200	STATION: 472+00	OFFSET: 2 ft RT	ALIGNMENT: -L-
COLLAR ELEV.: 166.0 ft	TOTAL DEPTH: 10.4 ft	NORTHING: 372,097	EASTING: 2,001,198
CPT RIG/MAX. DOWN PRESSURE: CATLIN CPT/DPT-01 / 9 TONS (NO ANCHORS)		CONE TYPE: TYPE 2 PIEZOCONE	CONE ID: DSG0867
DRILLER: EDDIE SWAIN	OPERATOR: CATLIN	START DATE: 01/29/20	COMP. DATE: 01/29/20
		SURF. WATER DEPTH: N/A	

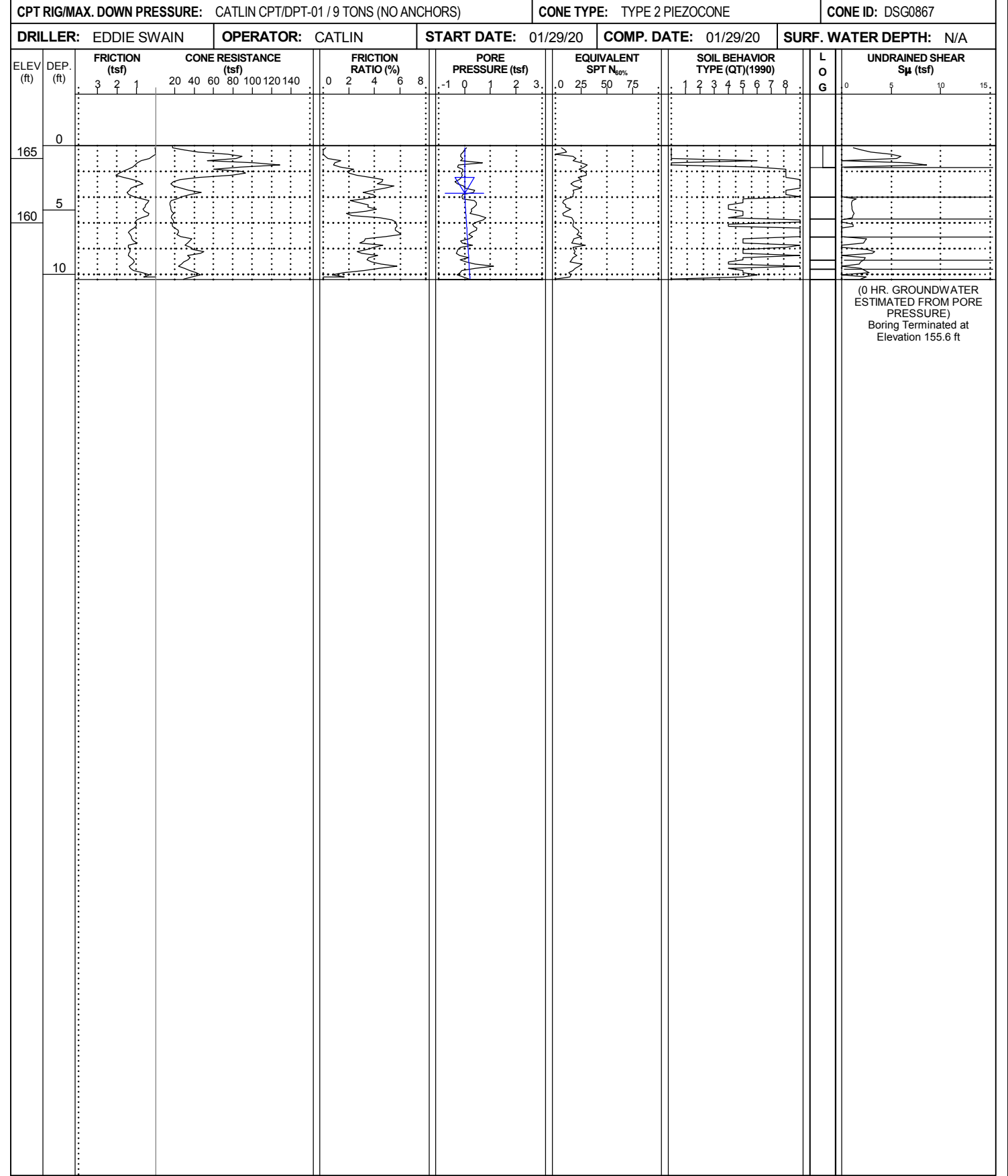

NCDOT CPT DOUBLE (PORTRAIT) NO-LITH 15987_GEO_RDWY_CATLIN_GTM-DRILLED_REVISED.GPJ NCDOT_CATLIN.GDT 07/30/20

CONE PENETROMETER TEST BORING REPORT



WBS: 47533.1.1	TIP: I-5987A	COUNTY: ROBESON/CUMBERLAND	GEOLOGIST: S. HUDSON
SITE DESCRIPTION: I-95 CUMBERLAND/ROBESON COUNTIES FROM US 301 (EXIT 22) TO I-95 BUSINESS/US 301 (EXIT 40)			GROUND WTR (ft)
BORING NO.: L_47700	STATION: 477+01	OFFSET: 2 ft RT	ALIGNMENT: -L-
COLLAR ELEV.: 166.4 ft	TOTAL DEPTH: 10.5 ft	NORTHING: 372,596	EASTING: 2,001,233
CPT RIG/MAX. DOWN PRESSURE: CATLIN CPT/DPT-01 / 9 TONS (NO ANCHORS)		CONE TYPE: TYPE 2 PIEZOCONE	CONE ID: DSG0867
DRILLER: EDDIE SWAIN	OPERATOR: CATLIN	START DATE: 01/29/20	COMP. DATE: 01/29/20
		SURF. WATER DEPTH: N/A	

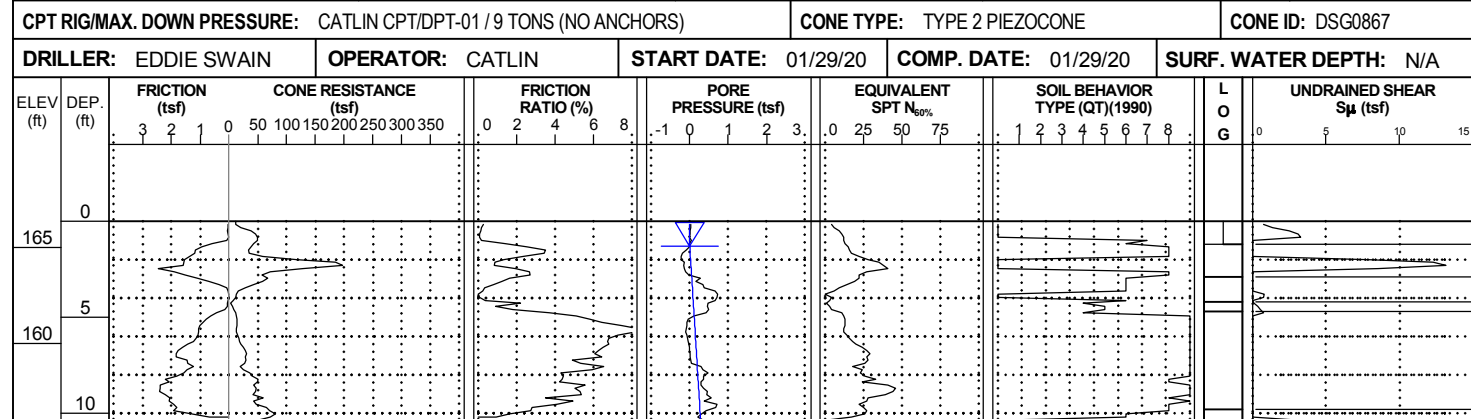

(0 HR. GROUNDWATER ESTIMATED FROM PORE PRESSURE)
Boring Terminated at Elevation 155.9 ft

WBS: 47533.1.1	TIP: I-5987A	COUNTY: ROBESON/CUMBERLAND	GEOLOGIST: S. HUDSON
SITE DESCRIPTION: I-95 CUMBERLAND/ROBESON COUNTIES FROM US 301 (EXIT 22) TO I-95 BUSINESS/US 301 (EXIT 40)			GROUND WTR (ft)
BORING NO.: L_48200	STATION: 482+00	OFFSET: 2 ft RT	ALIGNMENT: -L-
COLLAR ELEV.: 166.6 ft	TOTAL DEPTH: 10.5 ft	NORTHING: 373,094	EASTING: 2,001,268
CPT RIG/MAX. DOWN PRESSURE: CATLIN CPT/DPT-01 / 9 TONS (NO ANCHORS)		CONE TYPE: TYPE 2 PIEZOCONE	CONE ID: DSG0867
DRILLER: EDDIE SWAIN	OPERATOR: CATLIN	START DATE: 01/29/20	COMP. DATE: 01/29/20
		SURF. WATER DEPTH: N/A	

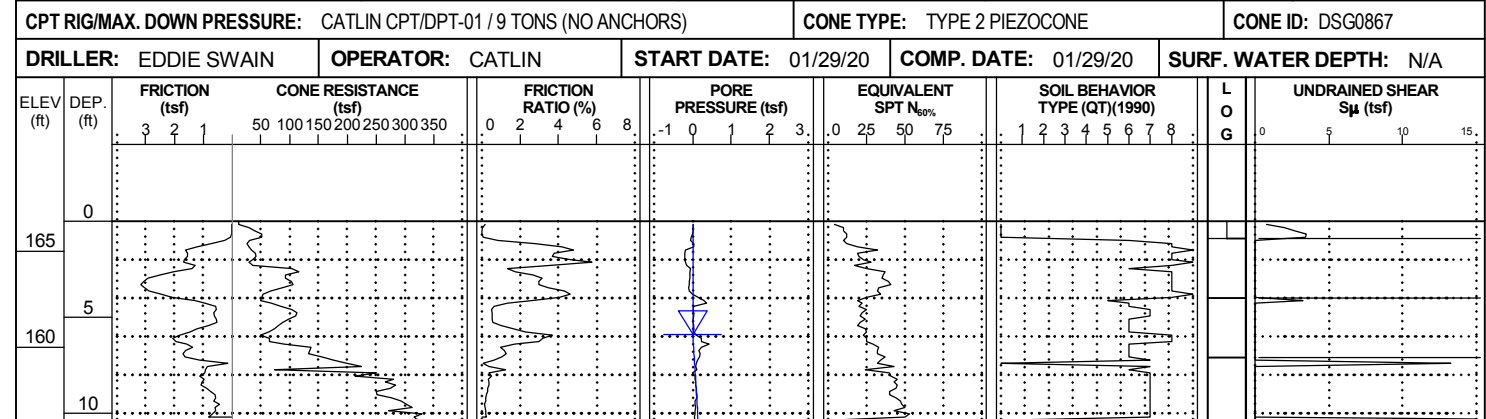

(0 HR. GROUNDWATER ESTIMATED FROM PORE PRESSURE)
Boring Terminated at Elevation 156.1 ft

NCDOT CPT DOUBLE (PORTRAIT) NO-LITH 15987_GEO_ROWY_CATLIN_GTM-DRILLED_REVISED.GPJ NCDOT_CATLIN.GDT 07/30/20

CONE PENETROMETER TEST BORING REPORT



WBS: 47533.1.1	TIP: I-5987A	COUNTY: ROBESON/CUMBERLAND	GEOLOGIST: S. HUDSON
SITE DESCRIPTION: I-95 CUMBERLAND/ROBESON COUNTIES FROM US 301 (EXIT 22) TO I-95 BUSINESS/US 301 (EXIT 40)			GROUND WTR (ft)
BORING NO.: L_48700	STATION: 487+00	OFFSET: 2 ft RT	ALIGNMENT: -L-
COLLAR ELEV.: 166.1 ft	TOTAL DEPTH: 10.5 ft	NORTHING: 373,593	EASTING: 2,001,304
CPT RIG/MAX. DOWN PRESSURE: CATLIN CPT/DPT-01 / 9 TONS (NO ANCHORS)		CONE TYPE: TYPE 2 PIEZOCONE	CONE ID: DSG0867
DRILLER: EDDIE SWAIN	OPERATOR: CATLIN	START DATE: 01/29/20	COMP. DATE: 01/29/20
		SURF. WATER DEPTH: N/A	

WBS: 47533.1.1	TIP: I-5987A	COUNTY: ROBESON/CUMBERLAND	GEOLOGIST: S. HUDSON
SITE DESCRIPTION: I-95 CUMBERLAND/ROBESON COUNTIES FROM US 301 (EXIT 22) TO I-95 BUSINESS/US 301 (EXIT 40)			GROUND WTR (ft)
BORING NO.: L_49200	STATION: 492+00	OFFSET: 2 ft RT	ALIGNMENT: -L-
COLLAR ELEV.: 165.8 ft	TOTAL DEPTH: 10.5 ft	NORTHING: 374,092	EASTING: 2,001,339
CPT RIG/MAX. DOWN PRESSURE: CATLIN CPT/DPT-01 / 9 TONS (NO ANCHORS)		CONE TYPE: TYPE 2 PIEZOCONE	CONE ID: DSG0867
DRILLER: EDDIE SWAIN	OPERATOR: CATLIN	START DATE: 01/29/20	COMP. DATE: 01/29/20
		SURF. WATER DEPTH: N/A	

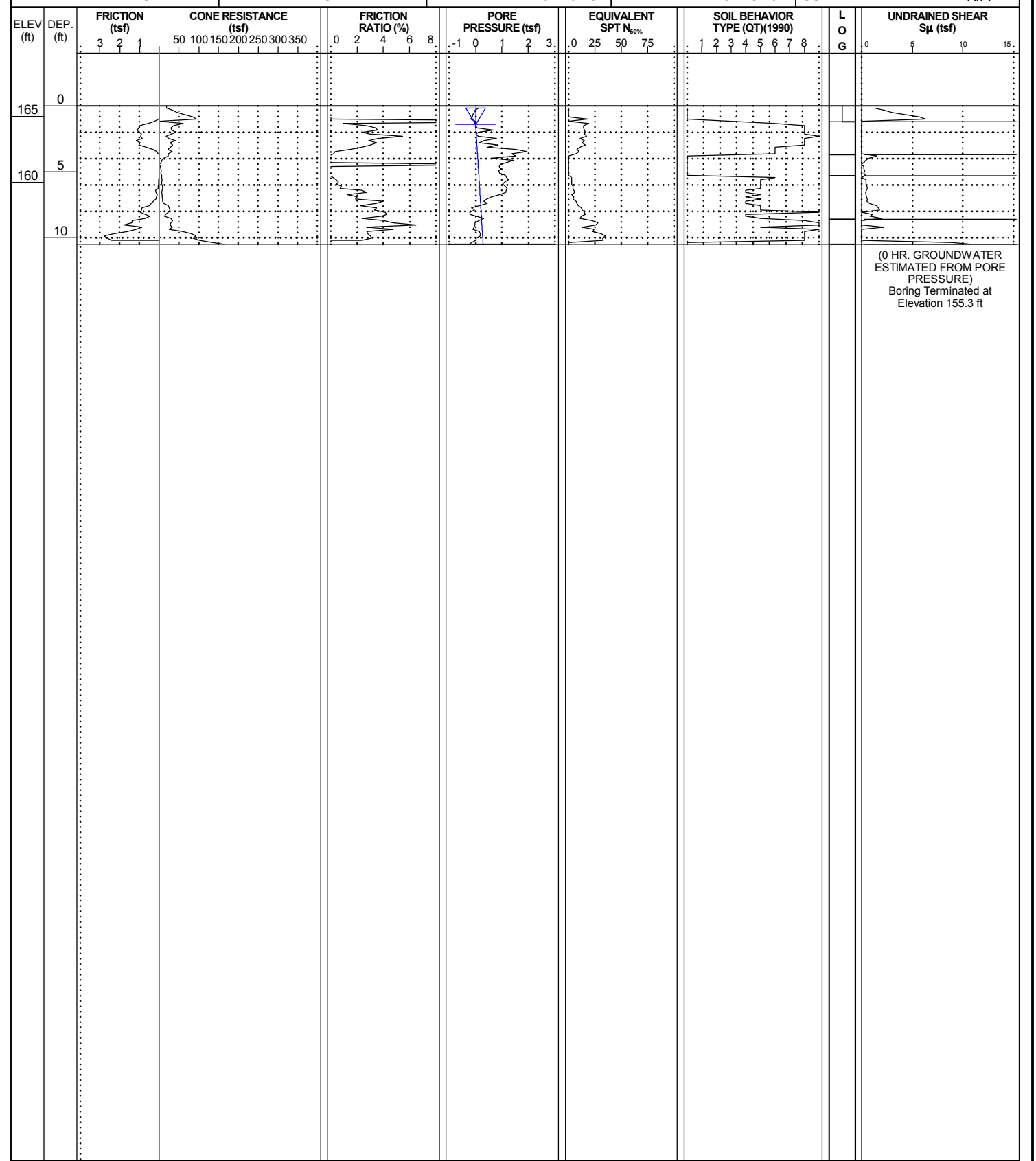
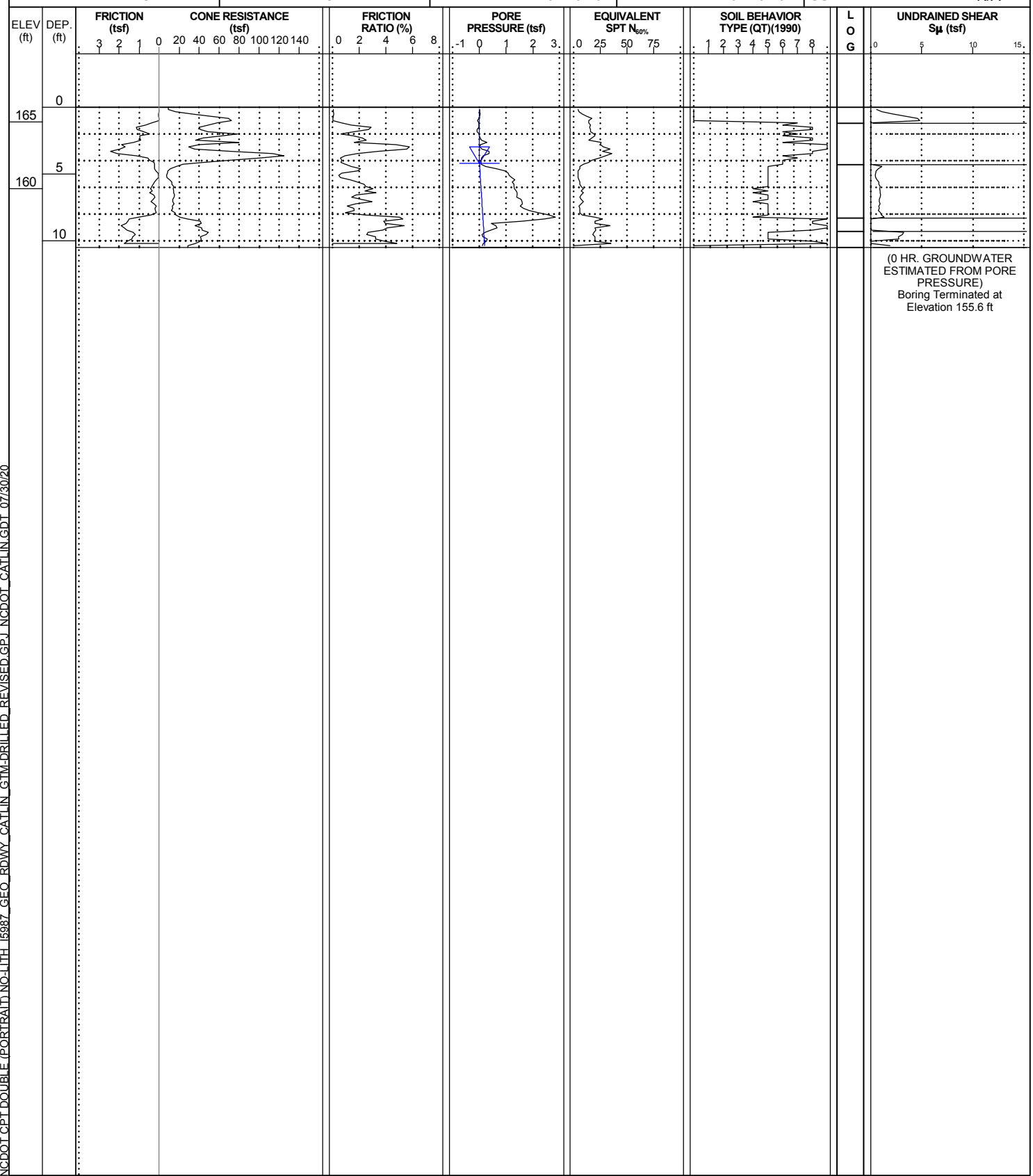

NCDOT CPT DOUBLE (PORTRAIT) NO-LITH 15987_GEO_ROWY_CATLIN_GTM-DRILLED_REVISED.GPJ NCDOT_CATLIN.GDT 07/30/20

CONE PENETROMETER TEST BORING REPORT



WBS: 47533.1.1	TIP: I-5987A	COUNTY: ROBESON/CUMBERLAND	GEOLOGIST: S. HUDSON
SITE DESCRIPTION: I-95 CUMBERLAND/ROBESON COUNTIES FROM US 301 (EXIT 22) TO I-95 BUSINESS/US 301 (EXIT 40)			GROUND WTR (ft)
BORING NO.: Y1ARPA_1100	STATION: 11+86	OFFSET: 44 ft RT	ALIGNMENT: -Y1ARPA-
COLLAR ELEV.: 151.3 ft	TOTAL DEPTH: 10.4 ft	NORTHING: 355,312	EASTING: 2,000,682
CPT RIG/MAX. DOWN PRESSURE: CATLIN CPT/DPT-01 / 9 TONS (NO ANCHORS)		CONE TYPE: TYPE 2 PIEZOCONE	CONE ID: DSG0867
DRILLER: EDDIE SWAIN	OPERATOR: CATLIN	START DATE: 01/30/20	COMP. DATE: 01/31/20
		SURF. WATER DEPTH: N/A	

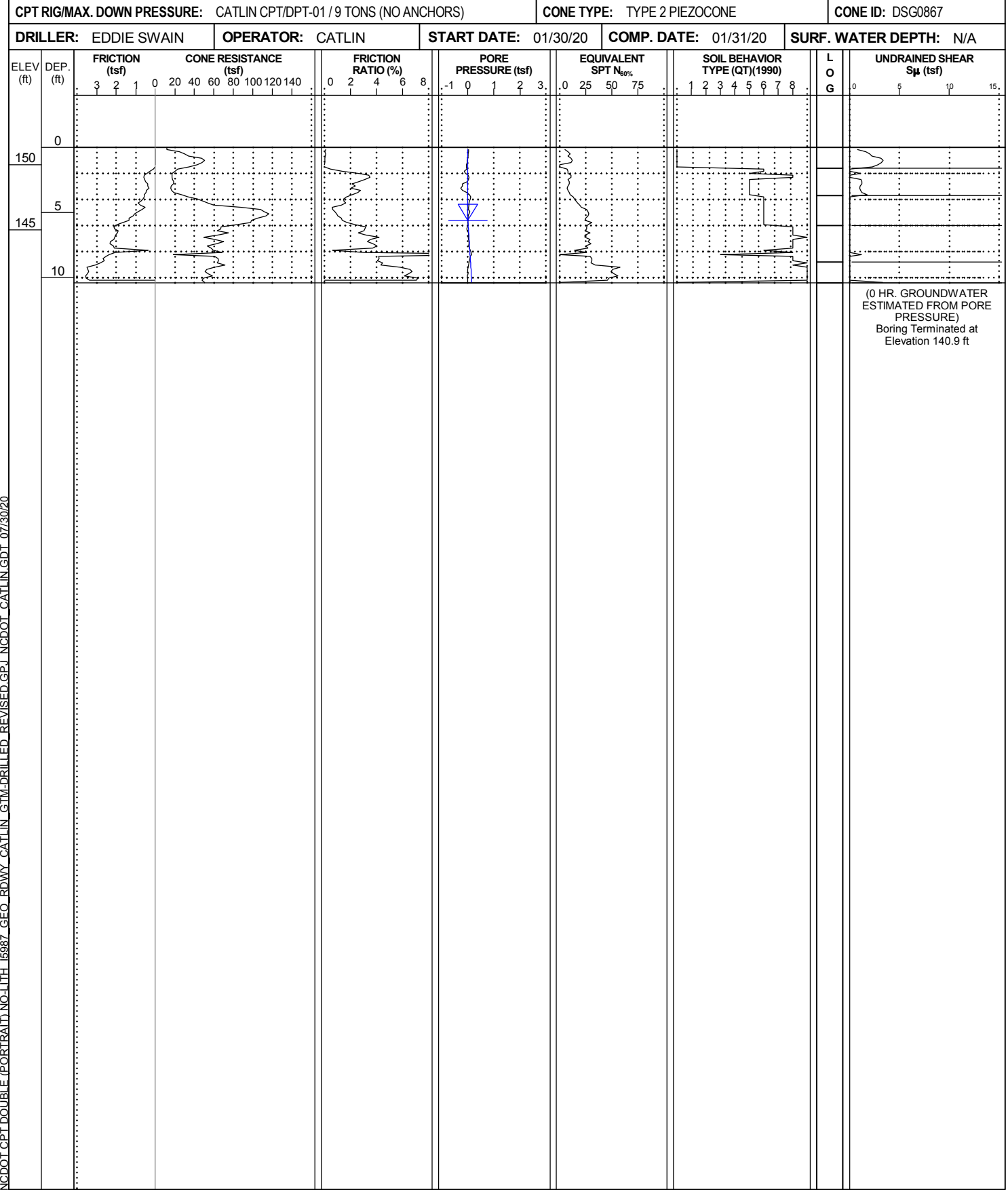

WBS: 47533.1.1	TIP: I-5987A	COUNTY: ROBESON/CUMBERLAND	GEOLOGIST: S. HUDSON
SITE DESCRIPTION: I-95 CUMBERLAND/ROBESON COUNTIES FROM US 301 (EXIT 22) TO I-95 BUSINESS/US 301 (EXIT 40)			GROUND WTR (ft)
BORING NO.: Y1ARPA_1550	STATION: 16+37	OFFSET: 7 ft LT	ALIGNMENT: -Y1ARPA-
COLLAR ELEV.: 151.4 ft	TOTAL DEPTH: 12.4 ft	NORTHING: 354,860	EASTING: 2,000,687
CPT RIG/MAX. DOWN PRESSURE: CATLIN CPT/DPT-01 / 9 TONS (NO ANCHORS)		CONE TYPE: TYPE 2 PIEZOCONE	CONE ID: DSG0867
DRILLER: EDDIE SWAIN	OPERATOR: CATLIN	START DATE: 01/30/20	COMP. DATE: 01/31/20
		SURF. WATER DEPTH: N/A	

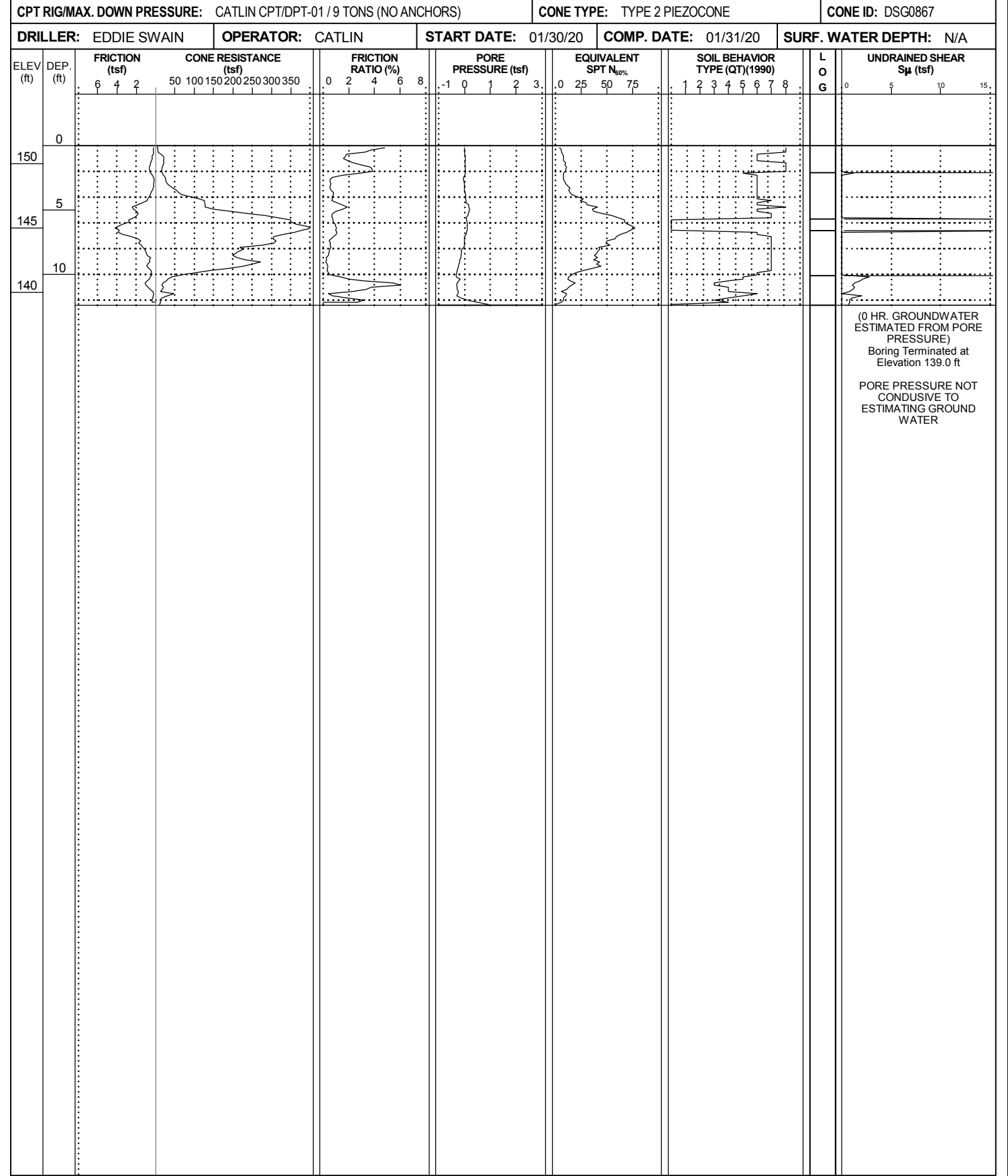

NCDOT CPT DOUBLE (PORTRAIT) NO-LITH 15987_GEO_RDWY_CATLIN_GTM-DRILLED_REVISED.GPJ_NCDOT_CATLIN.GDT_07/30/20

CONE PENETROMETER TEST BORING REPORT



WBS: 47533.1.1	TIP: I-5987A	COUNTY: ROBESON/CUMBERLAND	GEOLOGIST: S. HUDSON
SITE DESCRIPTION: I-95 CUMBERLAND/ROBESON COUNTIES FROM US 301 (EXIT 22) TO I-95 BUSINESS/US 301 (EXIT 40)			GROUND WTR (ft)
BORING NO.: Y3_2000	STATION: 22+15	OFFSET: 5 ft RT	ALIGNMENT: -Y3-
COLLAR ELEV.: 165.5 ft	TOTAL DEPTH: 32.5 ft	NORTHING: 370,682	EASTING: 2,000,590
CPT RIG/MAX. DOWN PRESSURE: CATLIN CPT/DPT-01 / 9 TONS (NO ANCHORS)		CONE TYPE: TYPE 2 PIEZOCONE	CONE ID: DSG0867
DRILLER: EDDIE SWAIN	OPERATOR: CATLIN	START DATE: 02/28/20	COMP. DATE: 02/28/20
		SURF. WATER DEPTH: N/A	

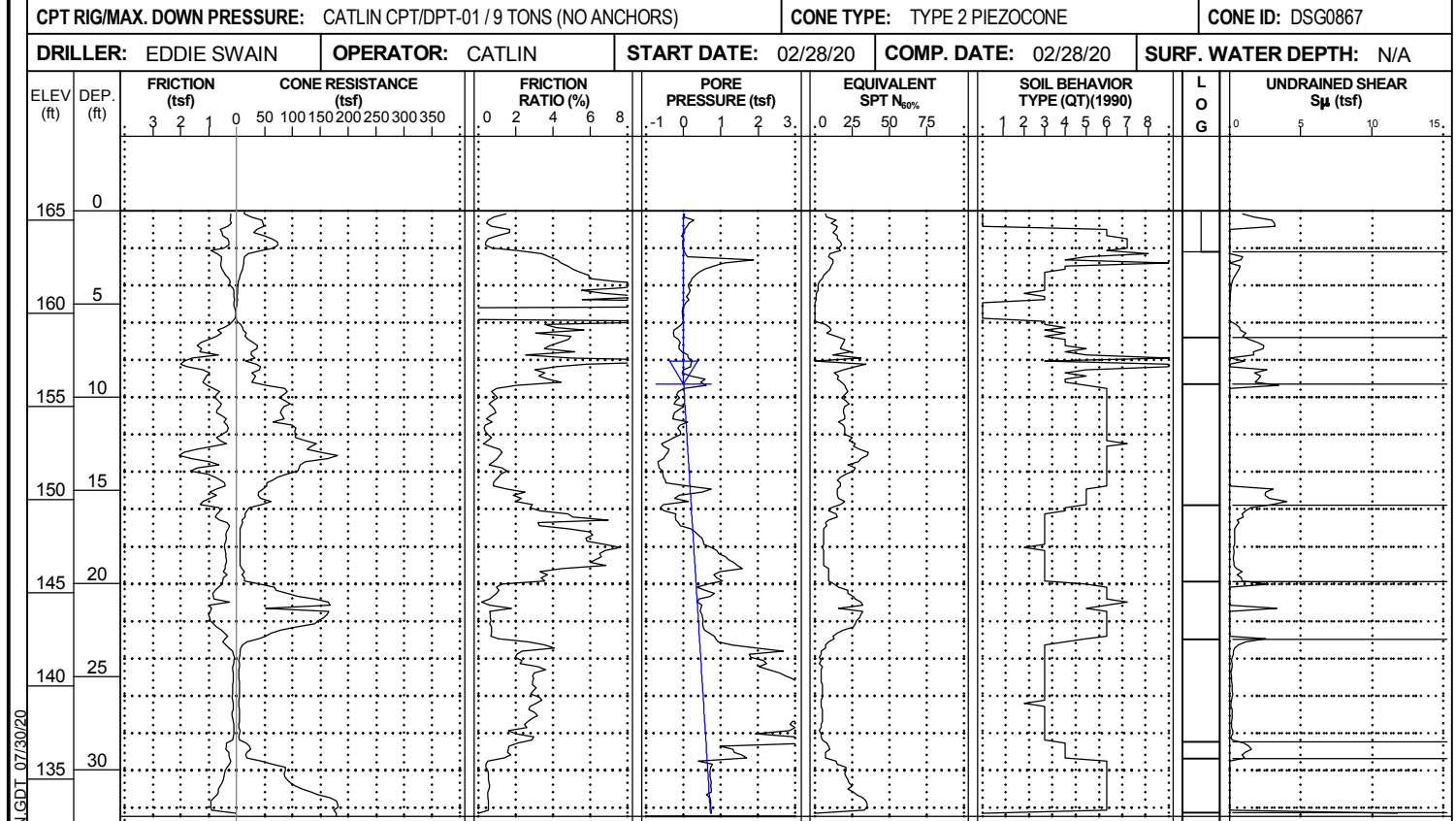

(0 HR. GROUNDWATER ESTIMATED FROM PORE PRESSURE)
Boring Terminated at Elevation 133.0 ft

WBS: 47533.1.1	TIP: I-5987A	COUNTY: ROBESON/CUMBERLAND	GEOLOGIST: S. HUDSON
SITE DESCRIPTION: I-95 CUMBERLAND/ROBESON COUNTIES FROM US 301 (EXIT 22) TO I-95 BUSINESS/US 301 (EXIT 40)			GROUND WTR (ft)
BORING NO.: Y3_2400	STATION: 26+15	OFFSET: 4 ft RT	ALIGNMENT: -Y3-
COLLAR ELEV.: 171.9 ft	TOTAL DEPTH: 52.4 ft	NORTHING: 370,970	EASTING: 2,000,868
CPT RIG/MAX. DOWN PRESSURE: CATLIN CPT/DPT-01 / 9 TONS (NO ANCHORS)		CONE TYPE: TYPE 2 PIEZOCONE	CONE ID: DSG0867
DRILLER: EDDIE SWAIN	OPERATOR: CATLIN	START DATE: 02/28/20	COMP. DATE: 02/28/20
		SURF. WATER DEPTH: N/A	

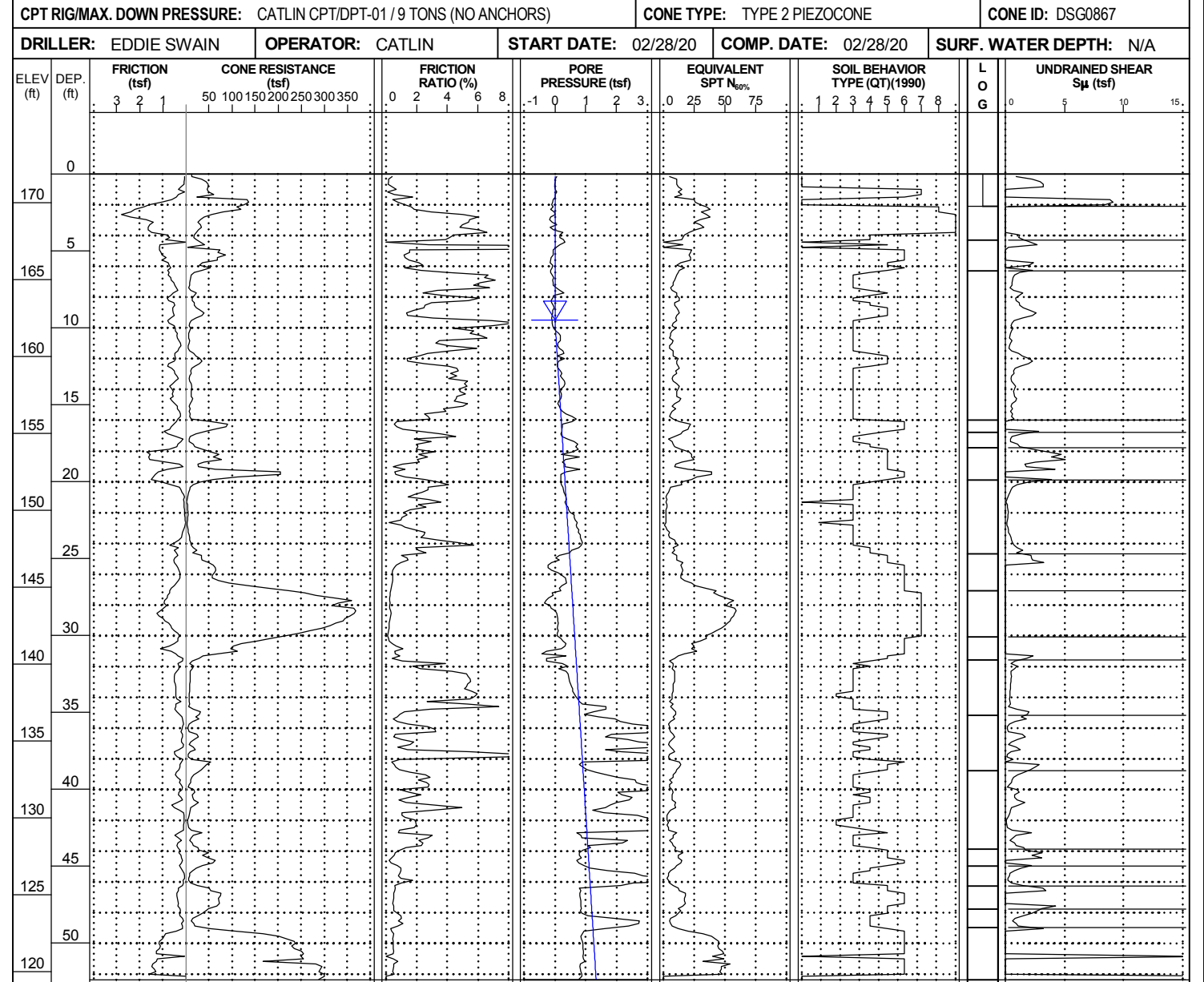

(0 HR. GROUNDWATER ESTIMATED FROM PORE PRESSURE)
Boring Terminated at Elevation 119.5 ft

NCDOI CPT DOUBLE (PORTRAIT) NO-LITH 15987_GEO_RDWY_CATLIN_GTM-DRILLED_REVISED.GPJ_NCDOT_CATLIN_GDT_07/30/20