

DS  
AR

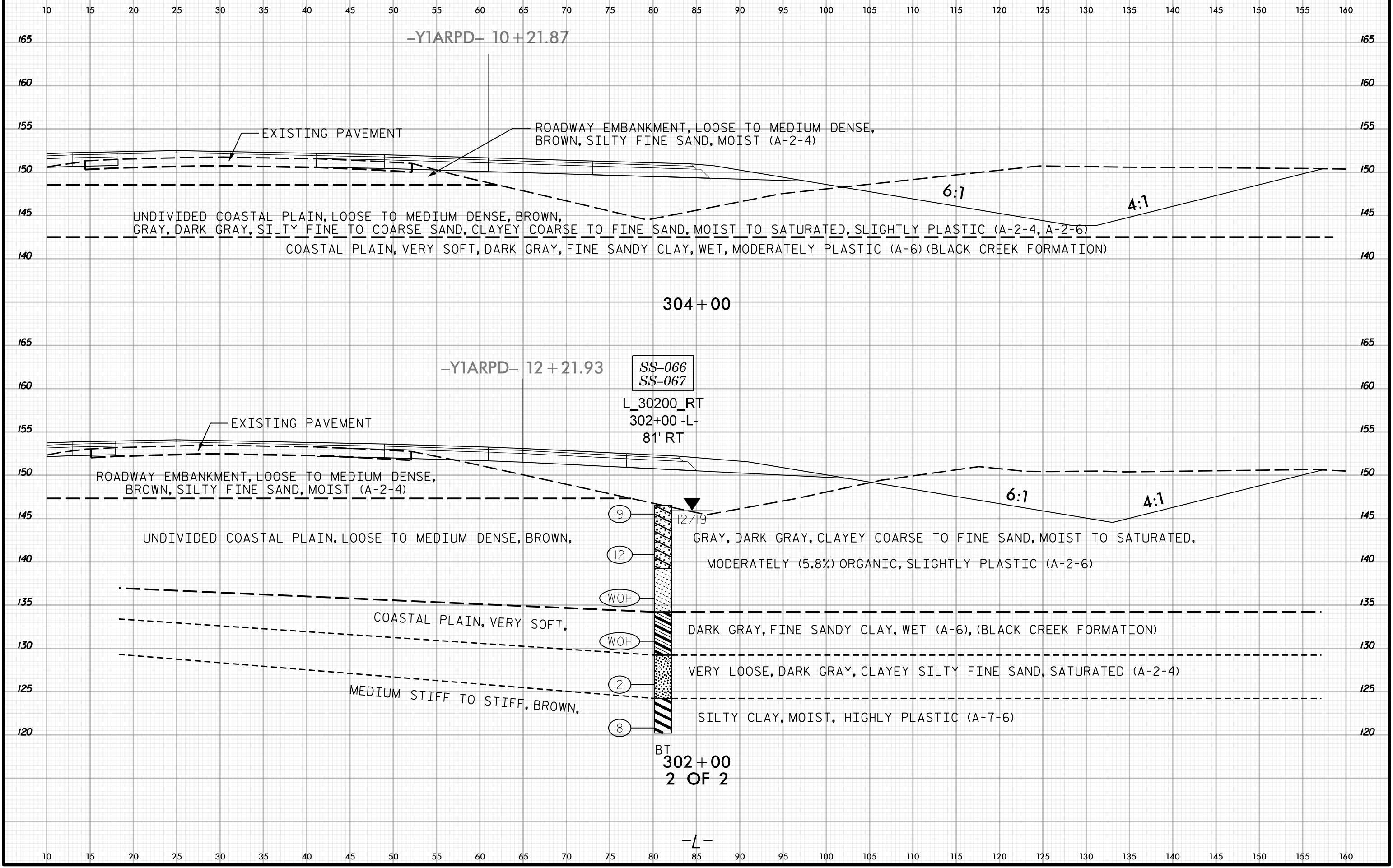

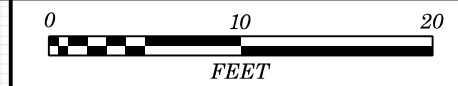
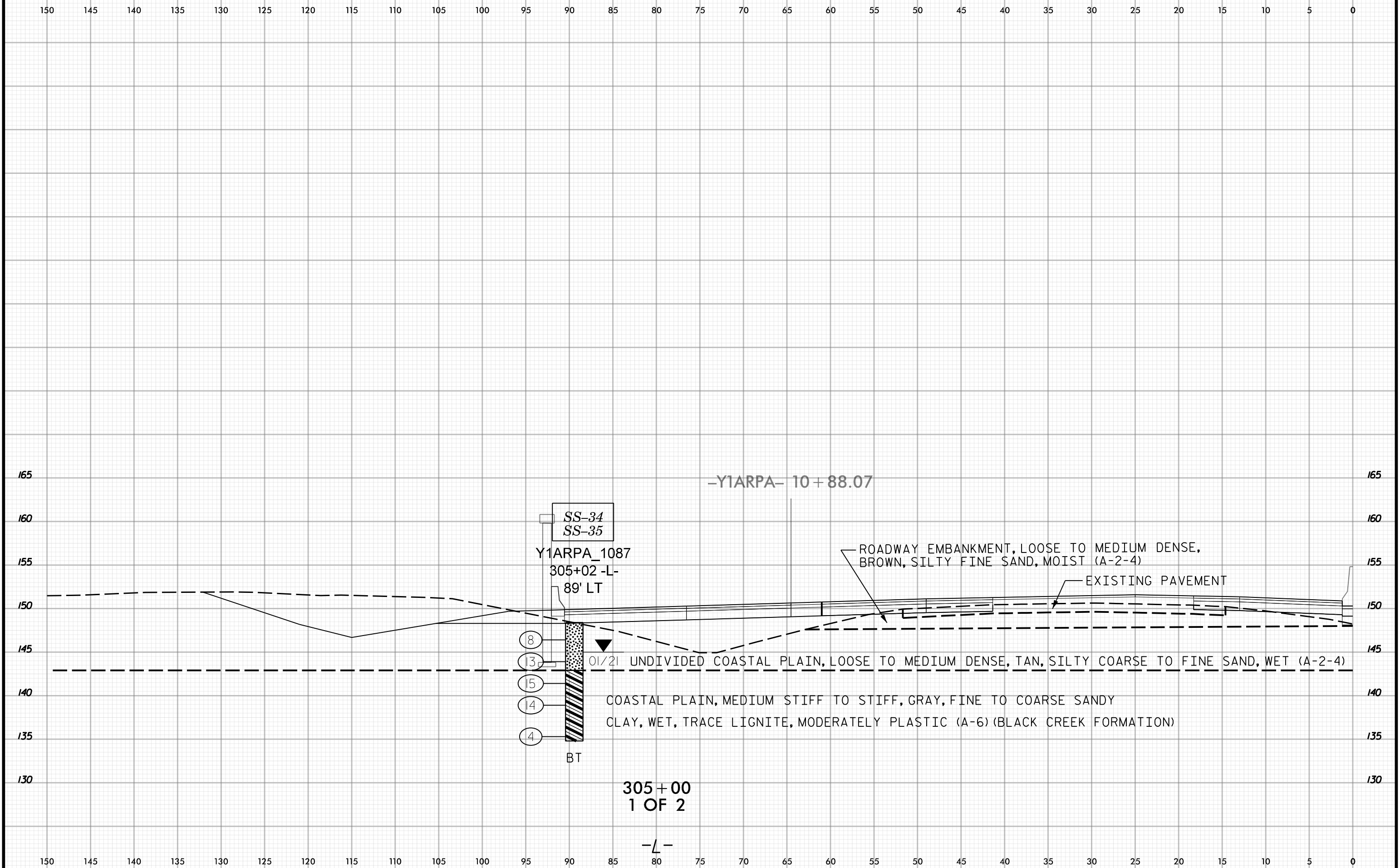

SS-34  
SS-35

Y1ARPA\_1087  
305+02 -L-  
89' LT

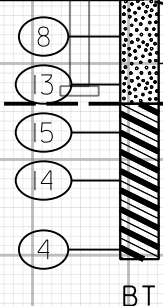

01/21 UNDIVIDED COASTAL PLAIN, LOOSE TO MEDIUM DENSE, TAN, SILTY COARSE TO FINE SAND, WET (A-2-4)

COASTAL PLAIN, MEDIUM STIFF TO STIFF, GRAY, FINE TO COARSE SANDY CLAY, WET, TRACE LIGNITE, MODERATELY PLASTIC (A-6) (BLACK CREEK FORMATION)

ROADWAY EMBANKMENT, LOOSE TO MEDIUM DENSE, BROWN, SILTY FINE SAND, MOIST (A-2-4)

EXISTING PAVEMENT

-Y1ARPA- 10 + 88.07

305 + 00  
1 OF 2

-L-

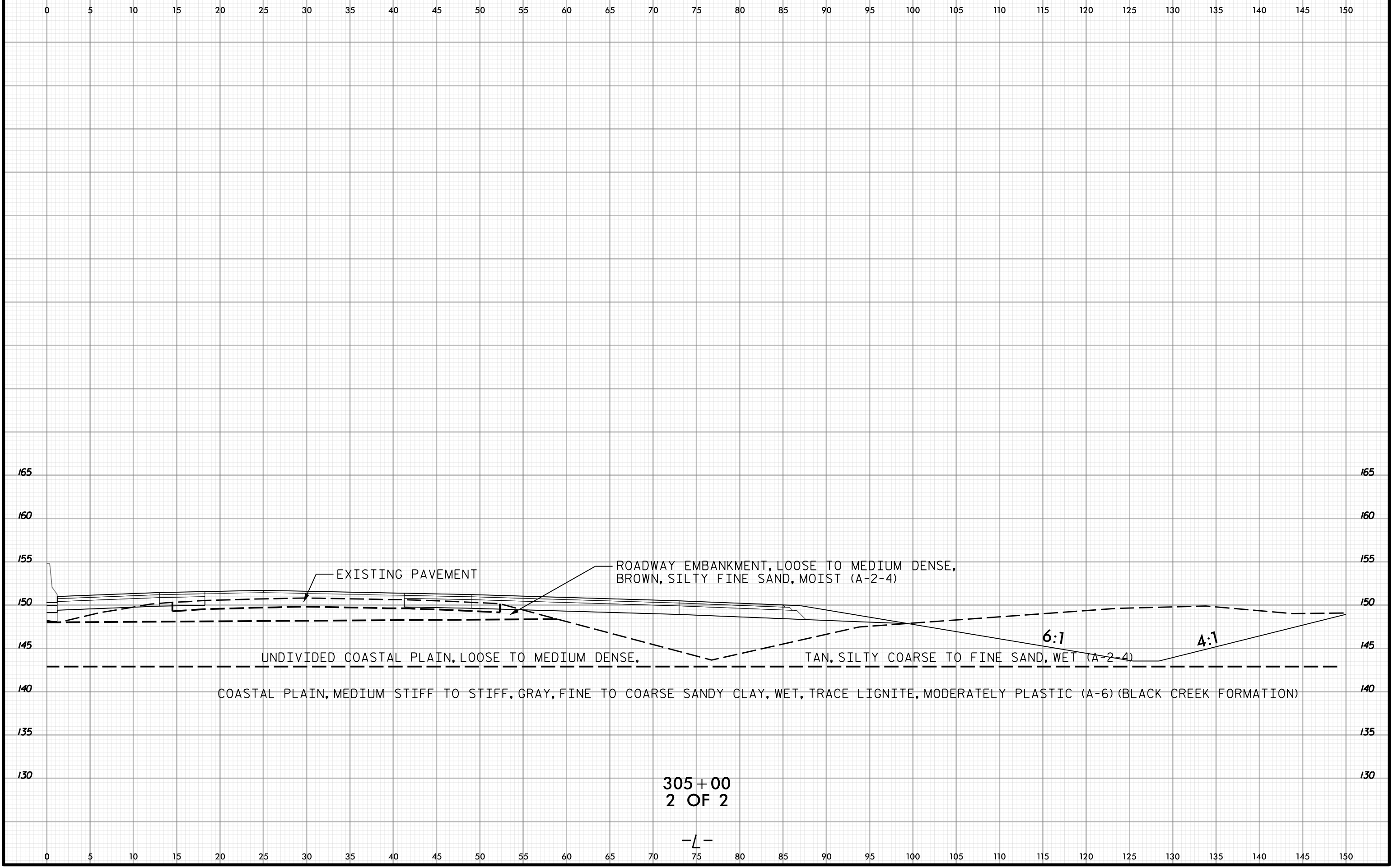

305+00  
2 OF 2

-L-

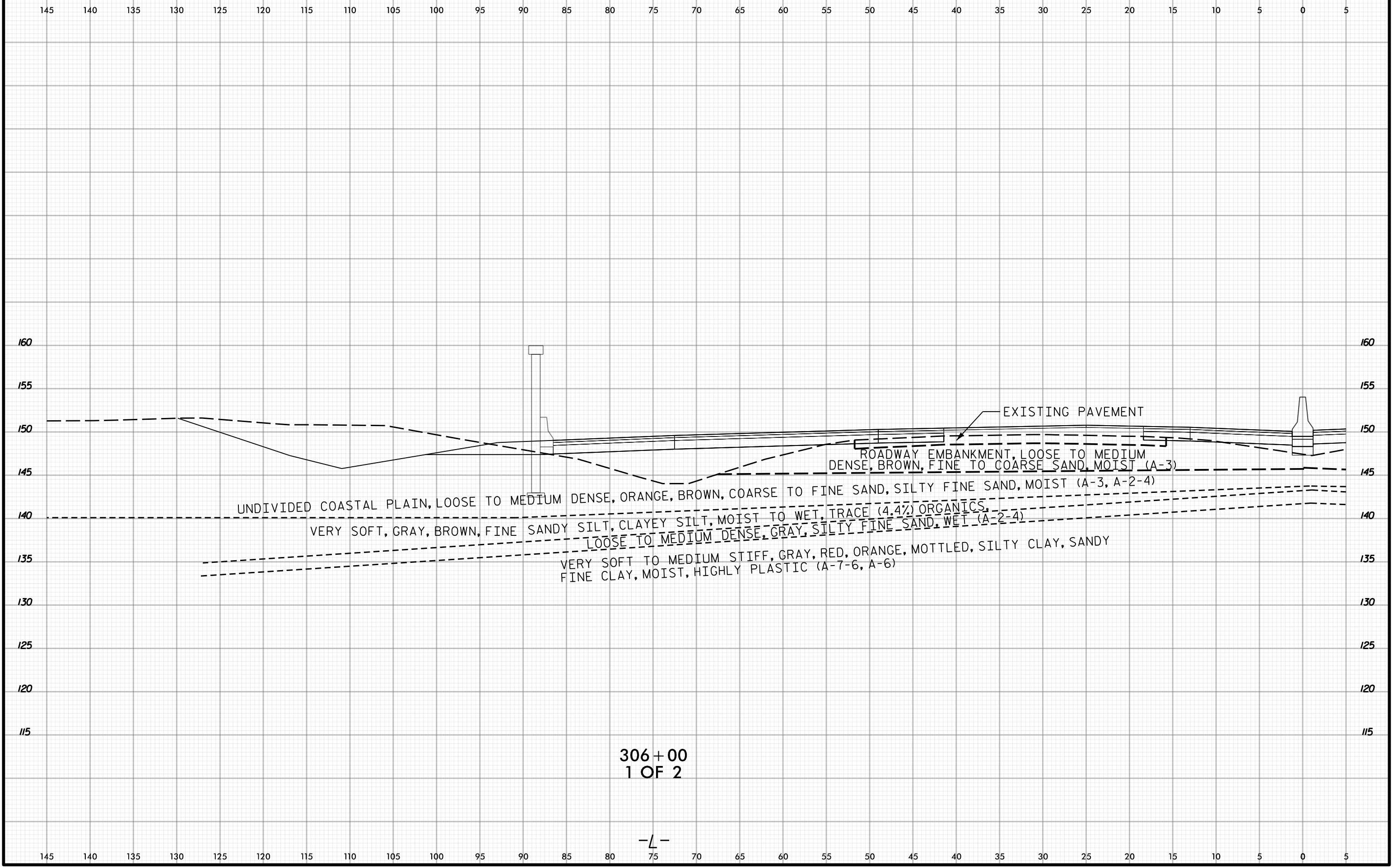



5 0 5 10 15 20 25 30 35 40 45 50 55 60 65 70 75 80 85 90 95 100 105 110 115 120 125 130 135 140 145

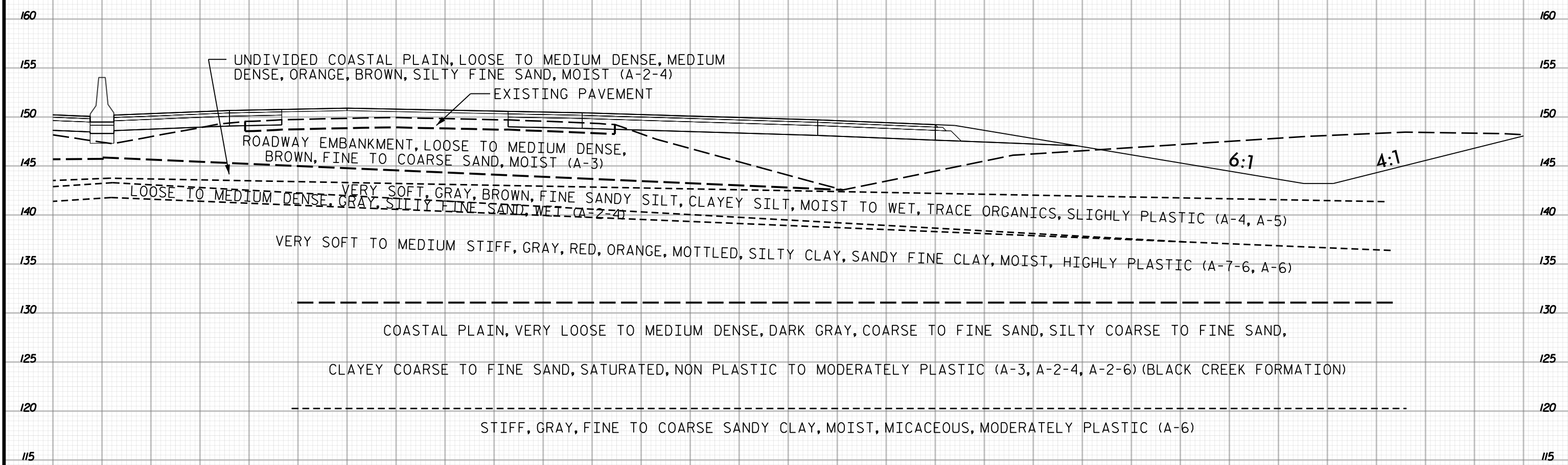

306+00  
2 OF 2

5 0 5 10 15 20 25 30 35 40 45 50 55 60 65 70 75 80 85 90 95 100 105 110 115 120 125 130 135 140 145



145 140 135 130 125 120 115 110 105 100 95 90 85 80 75 70 65 60 55 50 45 40 35 30 25 20 15 10 5 0 5

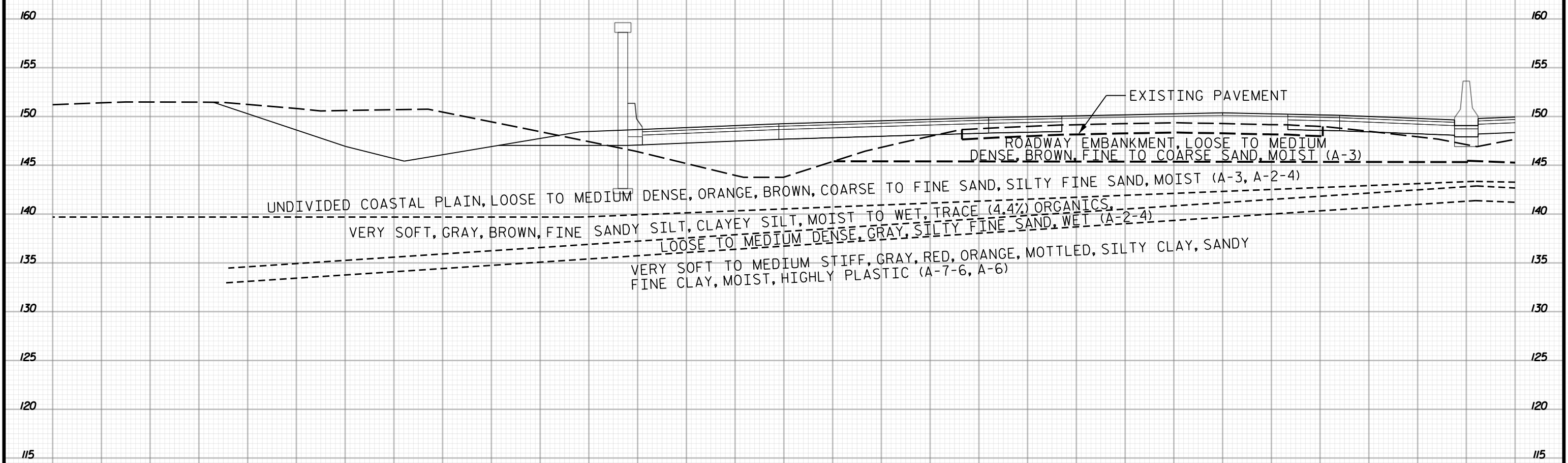

306+50  
1 OF 2

-L-

145 140 135 130 125 120 115 110 105 100 95 90 85 80 75 70 65 60 55 50 45 40 35 30 25 20 15 10 5 0 5



5 0 5 10 15 20 25 30 35 40 45 50 55 60 65 70 75 80 85 90 95 100 105 110 115 120 125 130 135 140 145

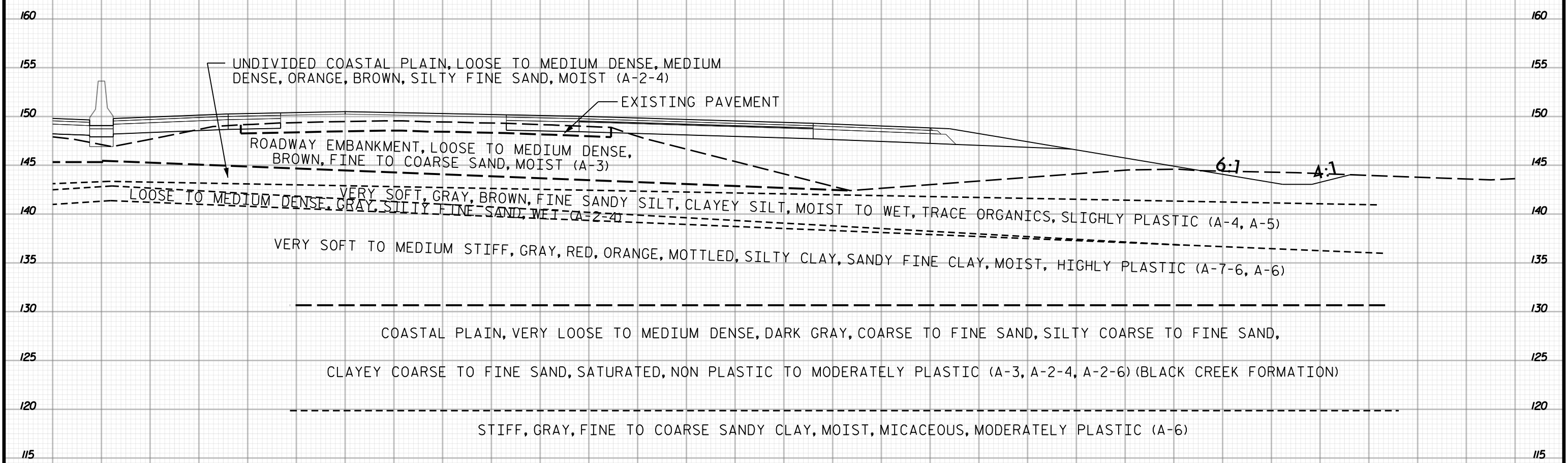

306+50  
2 OF 2

-L-

5 0 5 10 15 20 25 30 35 40 45 50 55 60 65 70 75 80 85 90 95 100 105 110 115 120 125 130 135 140 145



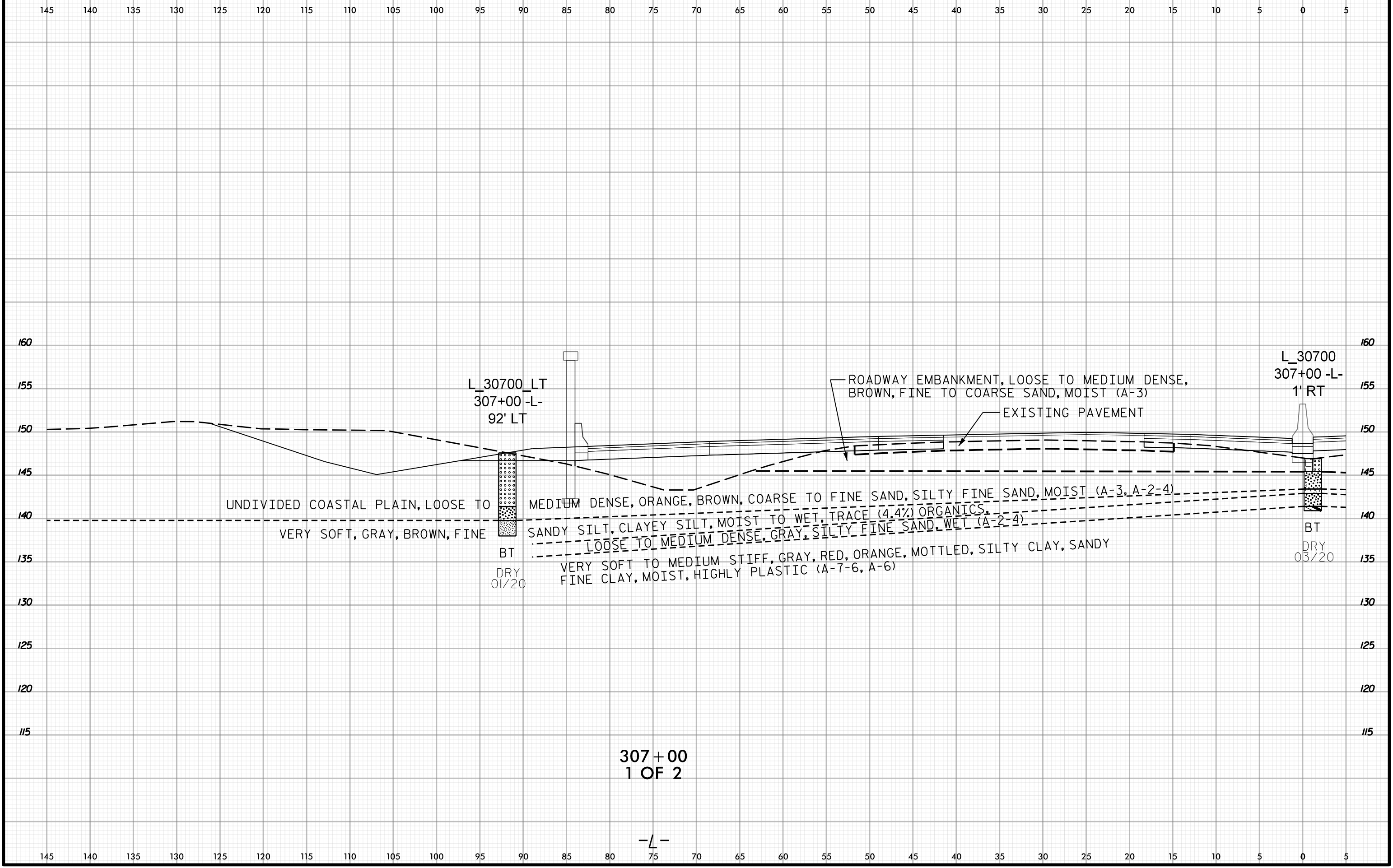
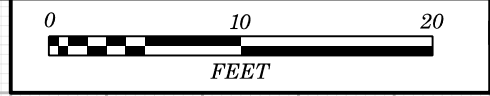

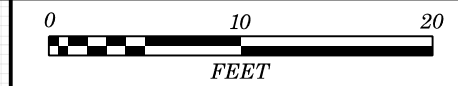

5 0 5 10 15 20 25 30 35 40 45 50 55 60 65 70 75 80 85 90 95 100 105 110 115 120 125 130 135 140 145

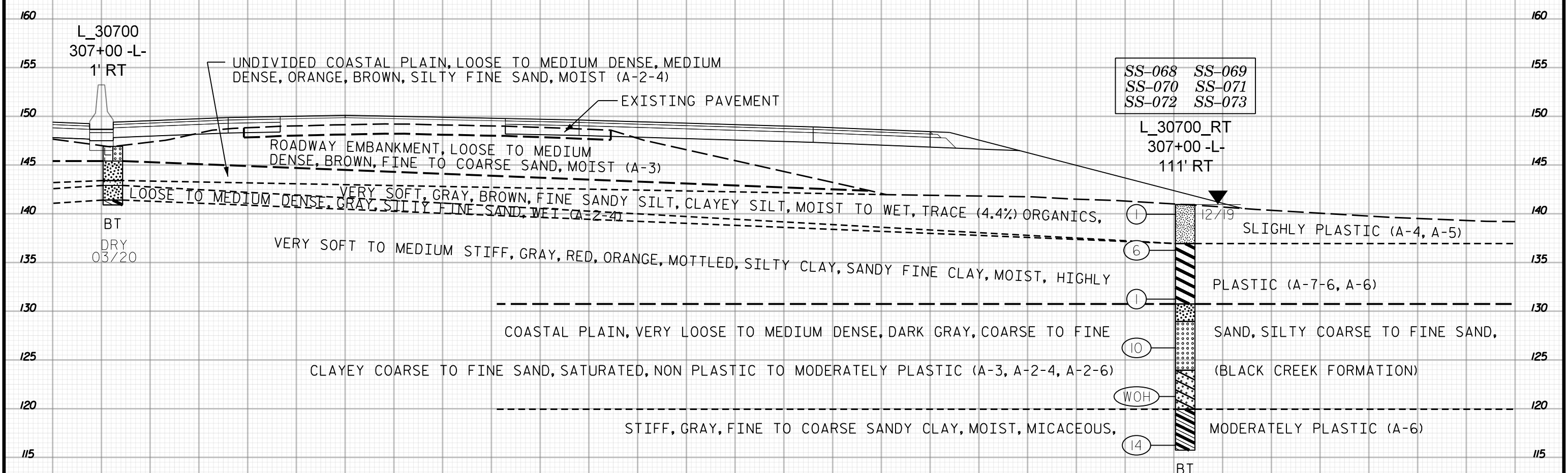

307+00  
2 OF 2

-L-

5 0 5 10 15 20 25 30 35 40 45 50 55 60 65 70 75 80 85 90 95 100 105 110 115 120 125 130 135 140 145



145 140 135 130 125 120 115 110 105 100 95 90 85 80 75 70 65 60 55 50 45 40 35 30 25 20 15 10 5 0 5

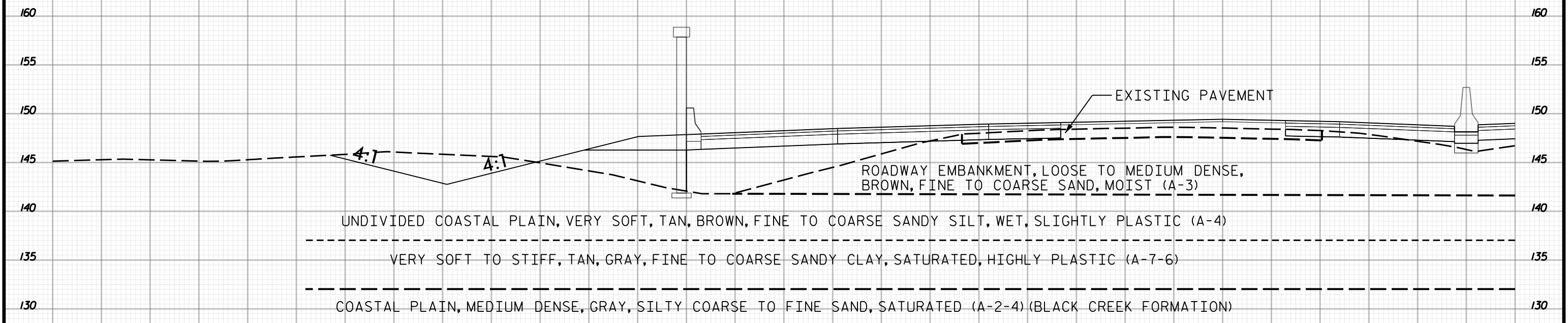

308 + 00

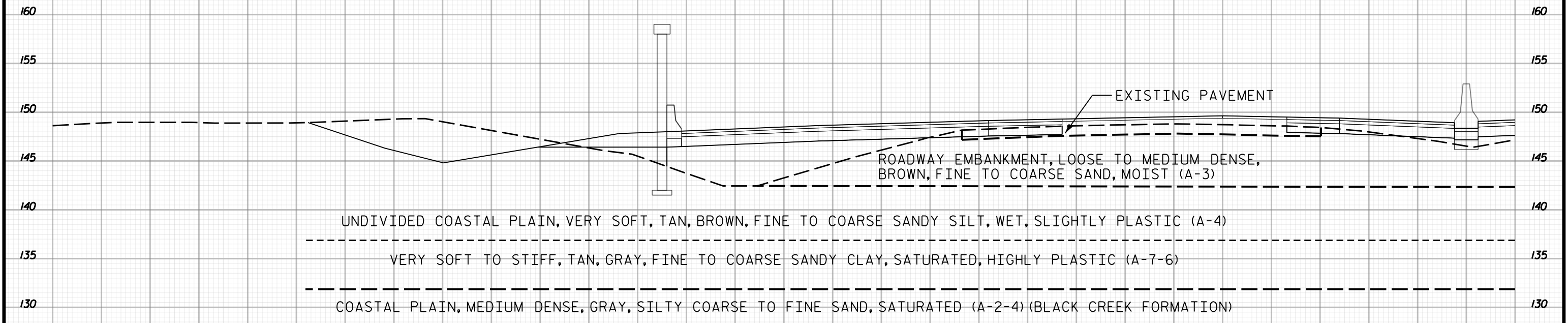

307 + 50  
1 OF 2

145 140 135 130 125 120 115 110 105 100 95 90 85 80 75 70 65 60 55 50 45 40 35 30 25 20 15 10 5 0 5

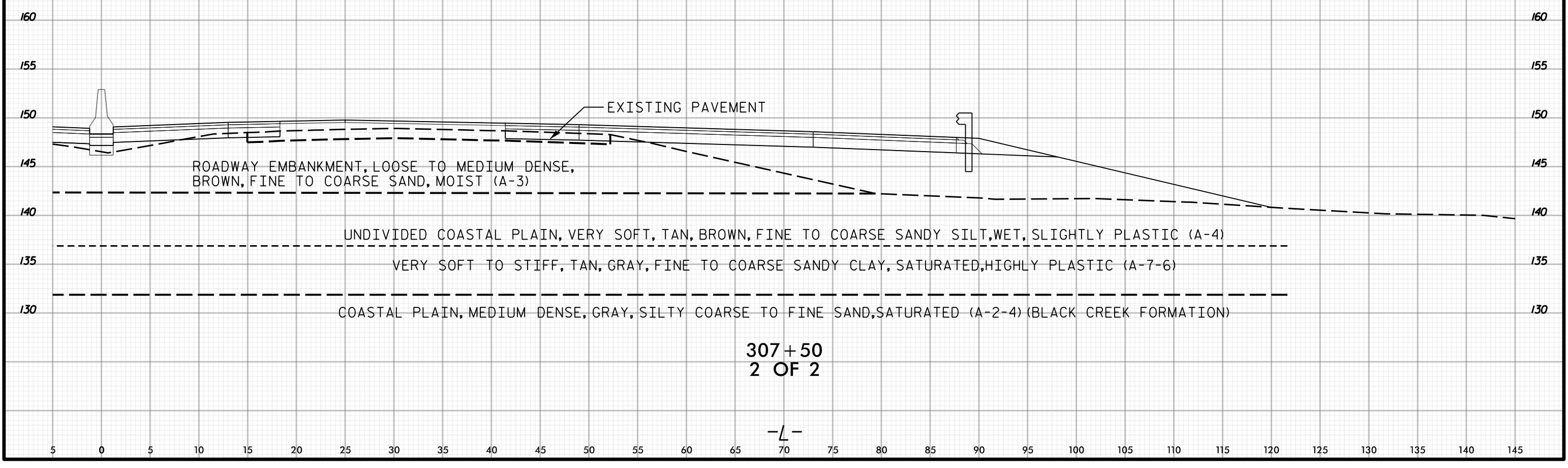
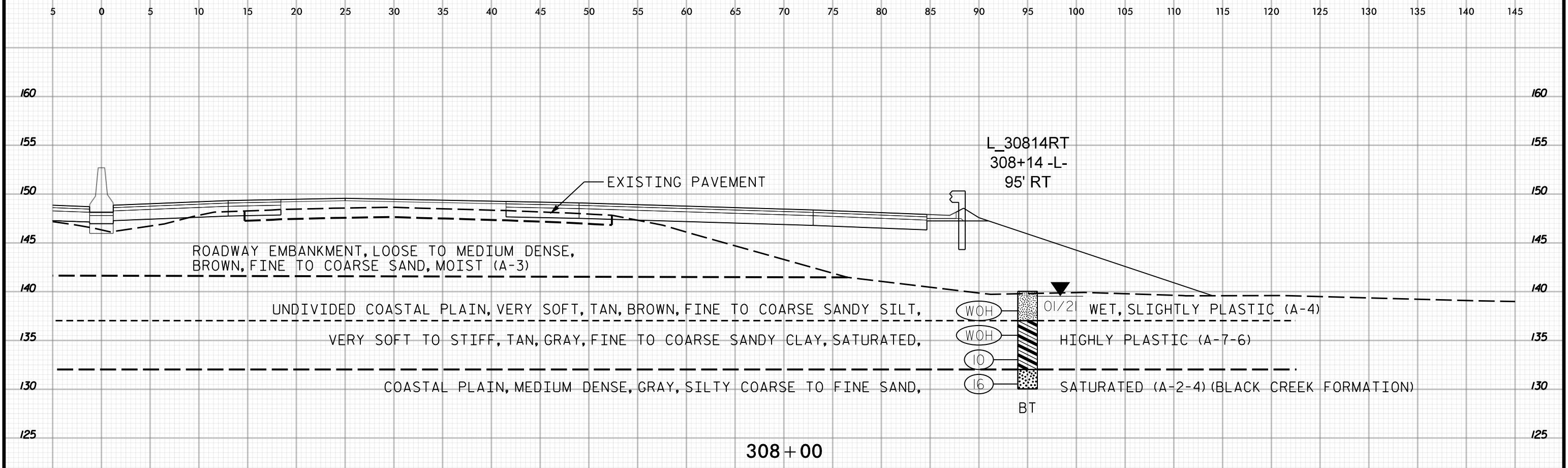
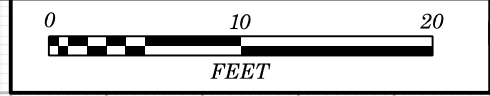

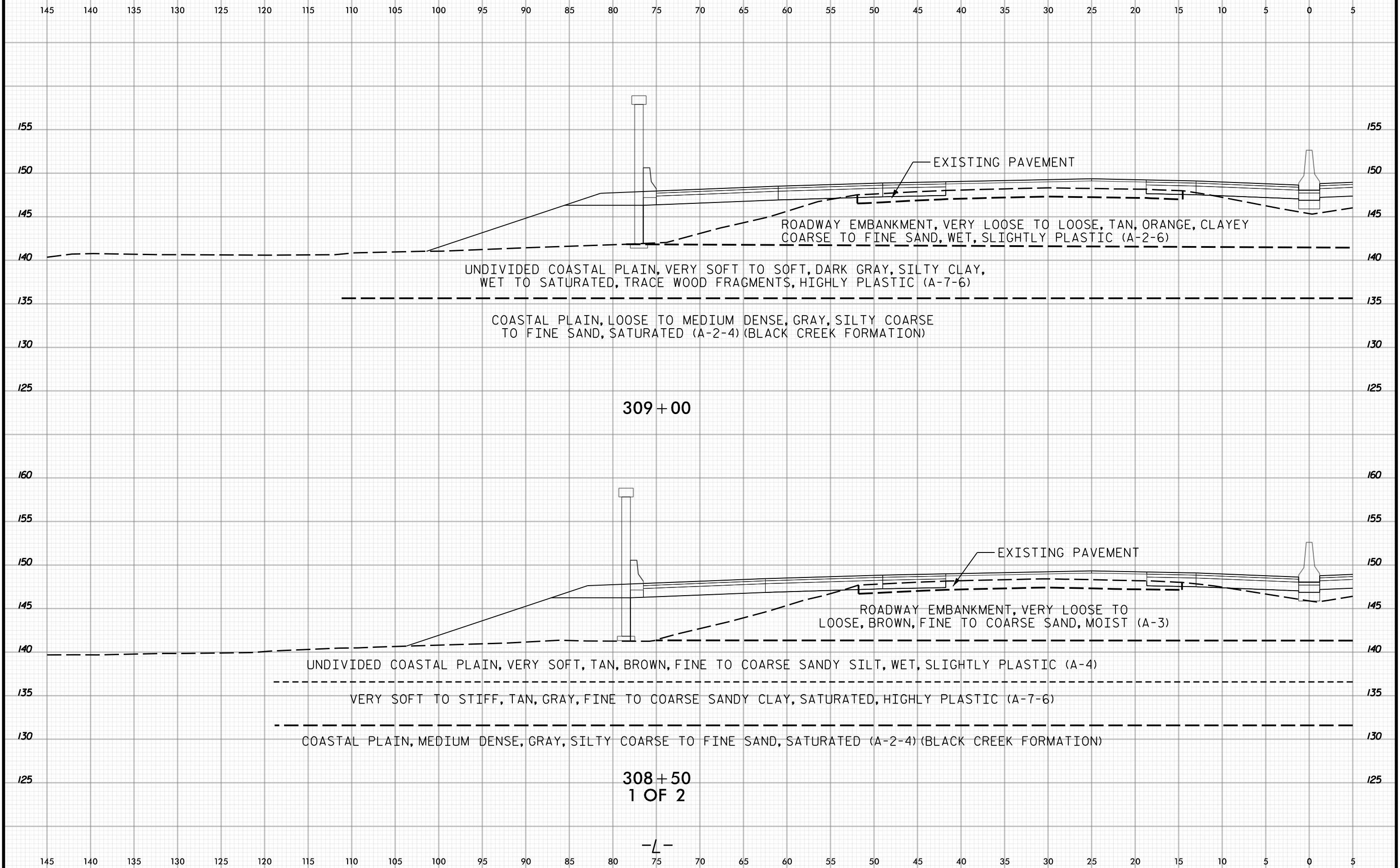

UNDIVIDED COASTAL PLAIN, VERY SOFT TO SOFT, DARK GRAY, SILTY CLAY, WET TO SATURATED, TRACE WOOD FRAGMENTS, HIGHLY PLASTIC (A-7-6)

COASTAL PLAIN, LOOSE TO MEDIUM DENSE, GRAY, SILTY COARSE TO FINE SAND, SATURATED (A-2-4) (BLACK CREEK FORMATION)

ROADWAY EMBANKMENT, VERY LOOSE TO LOOSE, TAN, ORANGE, CLAYEY COARSE TO FINE SAND, WET, SLIGHTLY PLASTIC (A-2-6)

EXISTING PAVEMENT

309+00

UNDIVIDED COASTAL PLAIN, VERY SOFT, TAN, BROWN, FINE TO COARSE SANDY SILT, WET, SLIGHTLY PLASTIC (A-4)

VERY SOFT TO STIFF, TAN, GRAY, FINE TO COARSE SANDY CLAY, SATURATED, HIGHLY PLASTIC (A-7-6)

COASTAL PLAIN, MEDIUM DENSE, GRAY, SILTY COARSE TO FINE SAND, SATURATED (A-2-4) (BLACK CREEK FORMATION)

ROADWAY EMBANKMENT, VERY LOOSE TO LOOSE, BROWN, FINE TO COARSE SAND, MOIST (A-3)

EXISTING PAVEMENT

308+50  
1 OF 2

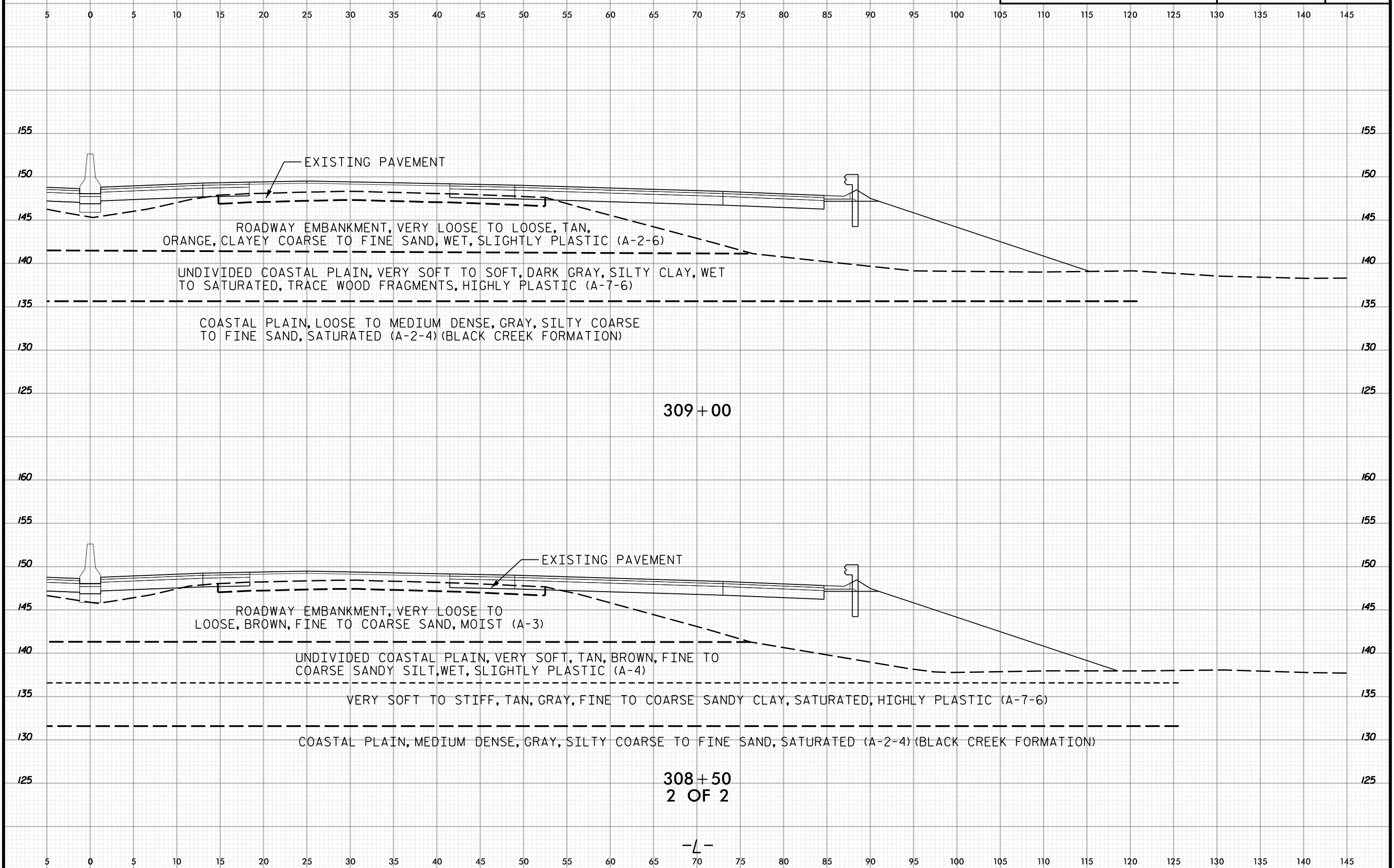

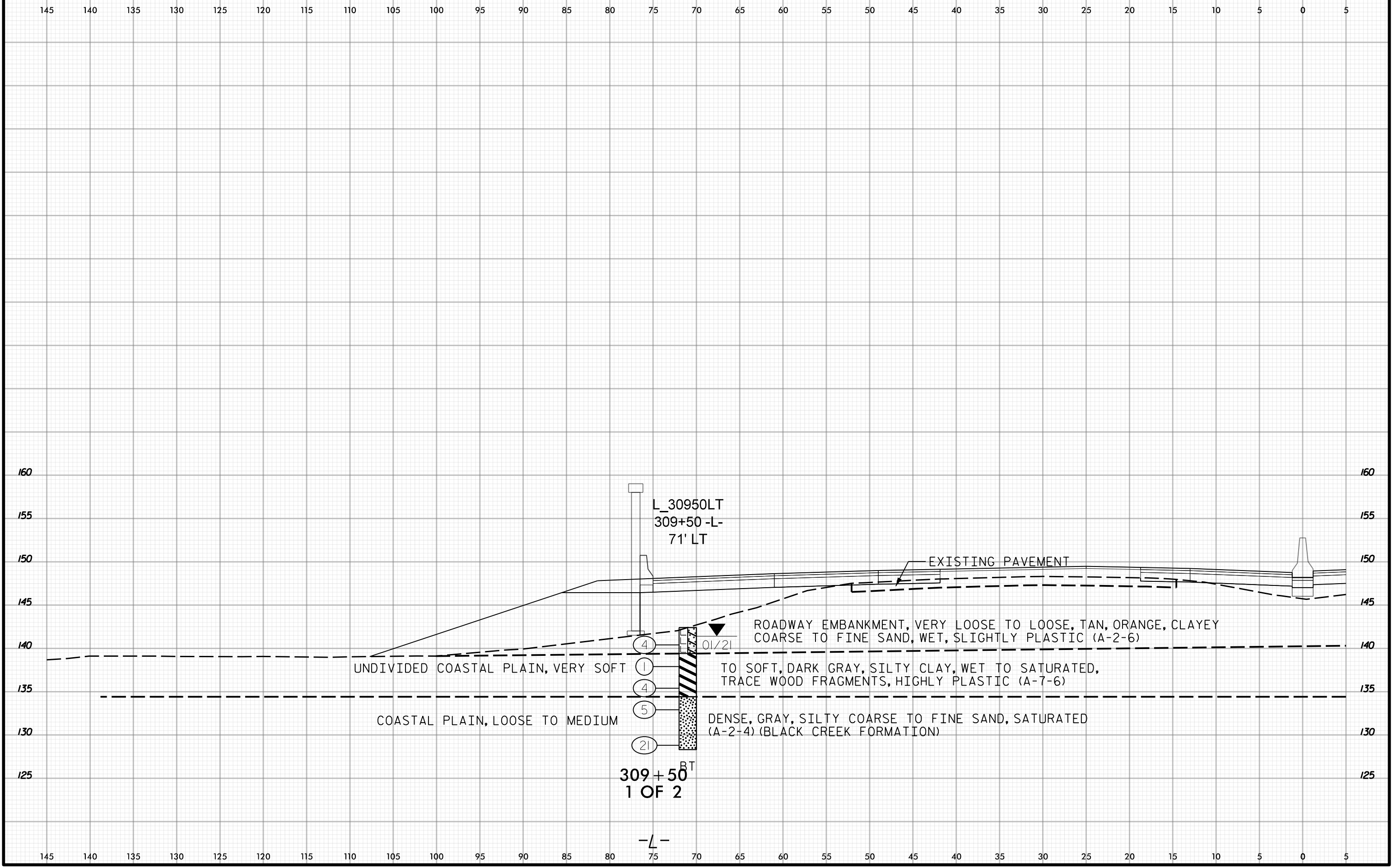
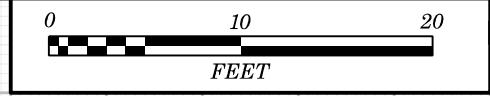

L\_30950LT  
309+50 -L-  
71' LT

EXISTING PAVEMENT

ROADWAY EMBANKMENT, VERY LOOSE TO LOOSE, TAN, ORANGE, CLAYEY  
COARSE TO FINE SAND, WET, SLIGHTLY PLASTIC (A-2-6)

UNDIVIDED COASTAL PLAIN, VERY SOFT

TO SOFT, DARK GRAY, SILTY CLAY, WET TO SATURATED,  
TRACE WOOD FRAGMENTS, HIGHLY PLASTIC (A-7-6)

COASTAL PLAIN, LOOSE TO MEDIUM

DENSE, GRAY, SILTY COARSE TO FINE SAND, SATURATED  
(A-2-4) (BLACK CREEK FORMATION)

309 + 50<sup>BT</sup>  
1 OF 2

-L-



5 0 5 10 15 20 25 30 35 40 45 50 55 60 65 70 75 80 85 90 95 100 105 110 115 120 125 130 135 140 145

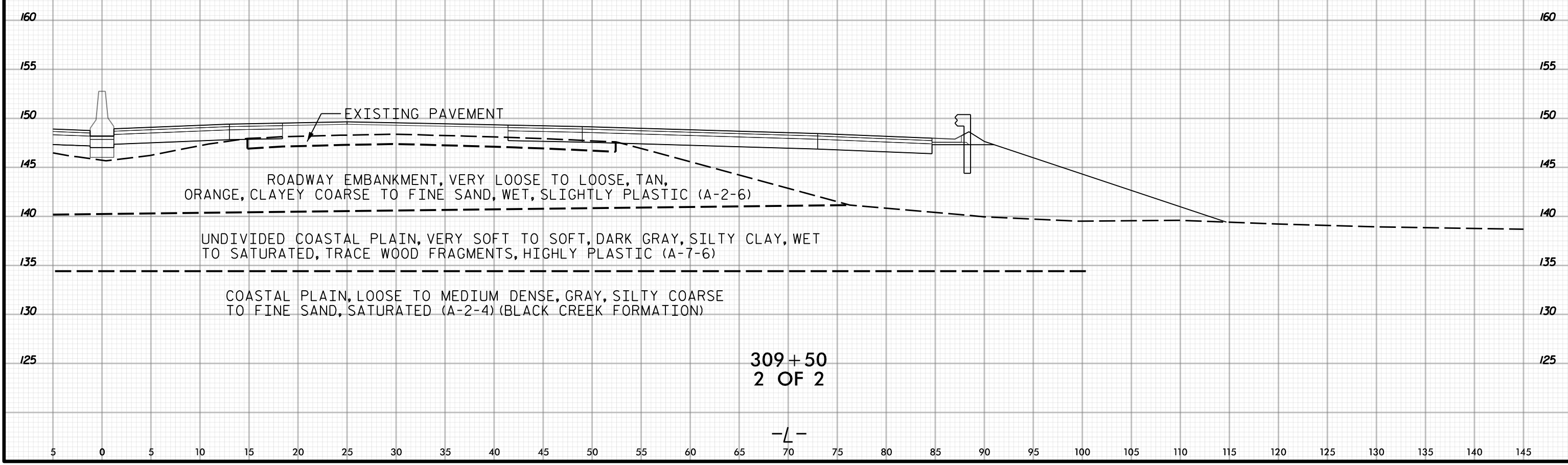

5 0 5 10 15 20 25 30 35 40 45 50 55 60 65 70 75 80 85 90 95 100 105 110 115 120 125 130 135 140 145



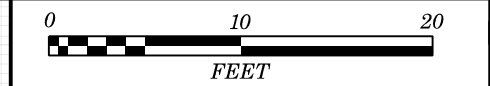

145 140 135 130 125 120 115 110 105 100 95 90 85 80 75 70 65 60 55 50 45 40 35 30 25 20 15 10 5 0 5

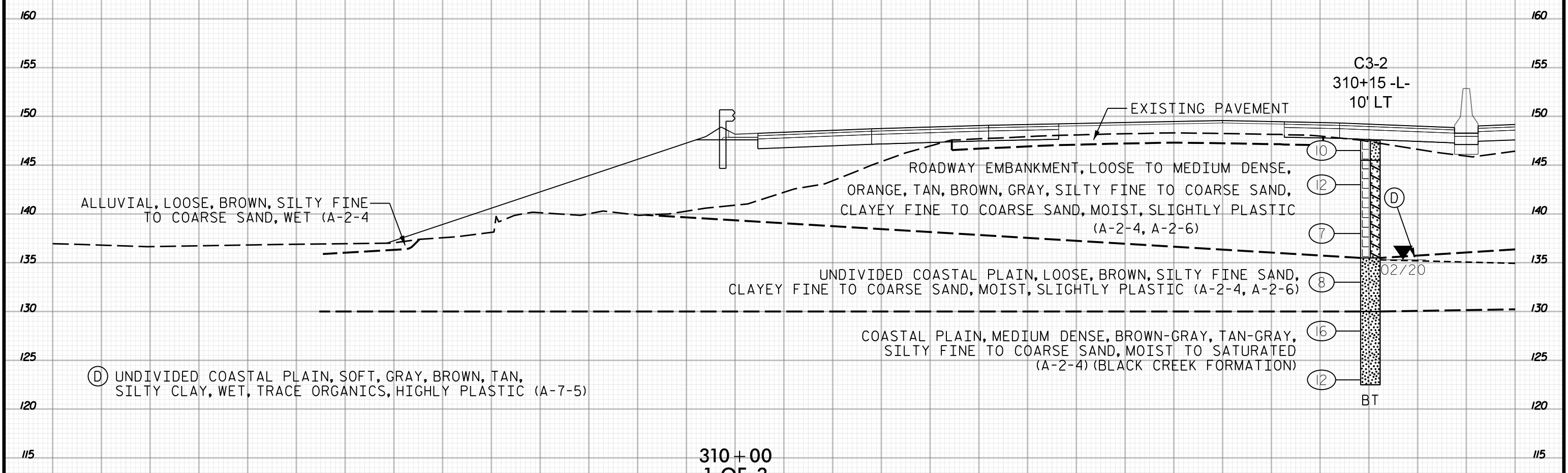

145 140 135 130 125 120 115 110 105 100 95 90 85 80 75 70 65 60 55 50 45 40 35 30 25 20 15 10 5 0 5



5 0 5 10 15 20 25 30 35 40 45 50 55 60 65 70 75 80 85 90 95 100 105 110 115 120 125 130 135 140 145

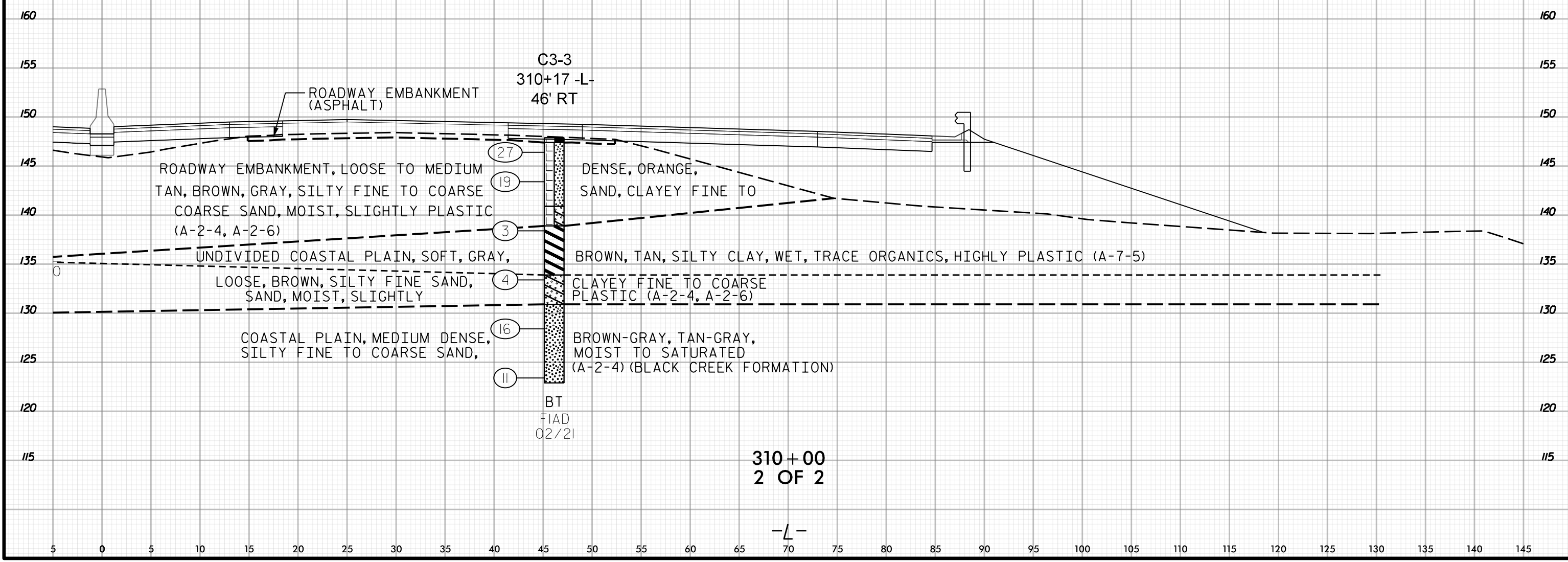

5 0 5 10 15 20 25 30 35 40 45 50 55 60 65 70 75 80 85 90 95 100 105 110 115 120 125 130 135 140 145



145 140 135 130 125 120 115 110 105 100 95 90 85 80 75 70 65 60 55 50 45 40 35 30 25 20 15 10 5 0 5

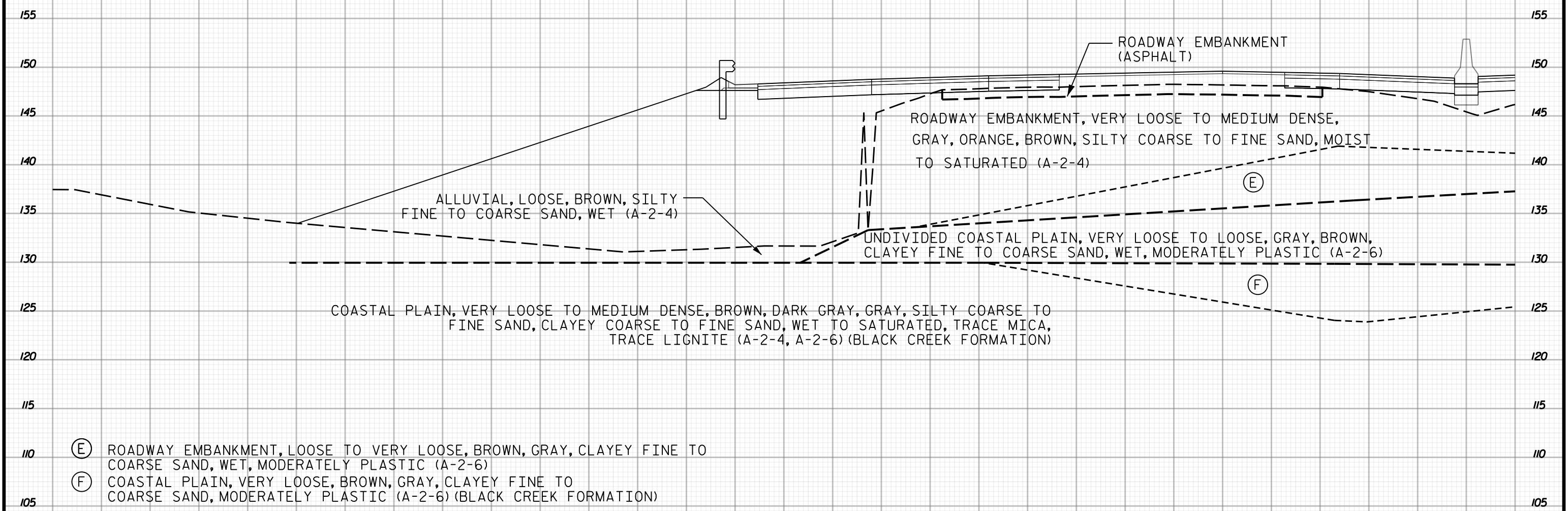

- (E) ROADWAY EMBANKMENT, LOOSE TO VERY LOOSE, BROWN, GRAY, CLAYEY FINE TO COARSE SAND, WET, MODERATELY PLASTIC (A-2-6)
- (F) COASTAL PLAIN, VERY LOOSE, BROWN, GRAY, CLAYEY FINE TO COARSE SAND, MODERATELY PLASTIC (A-2-6) (BLACK CREEK FORMATION)

310 + 50  
1 OF 2

-L-

145 140 135 130 125 120 115 110 105 100 95 90 85 80 75 70 65 60 55 50 45 40 35 30 25 20 15 10 5 0 5

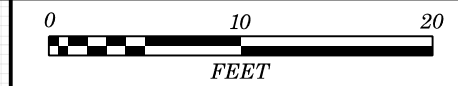

5 0 5 10 15 20 25 30 35 40 45 50 55 60 65 70 75 80 85 90 95 100 105 110 115 120 125 130 135 140 145

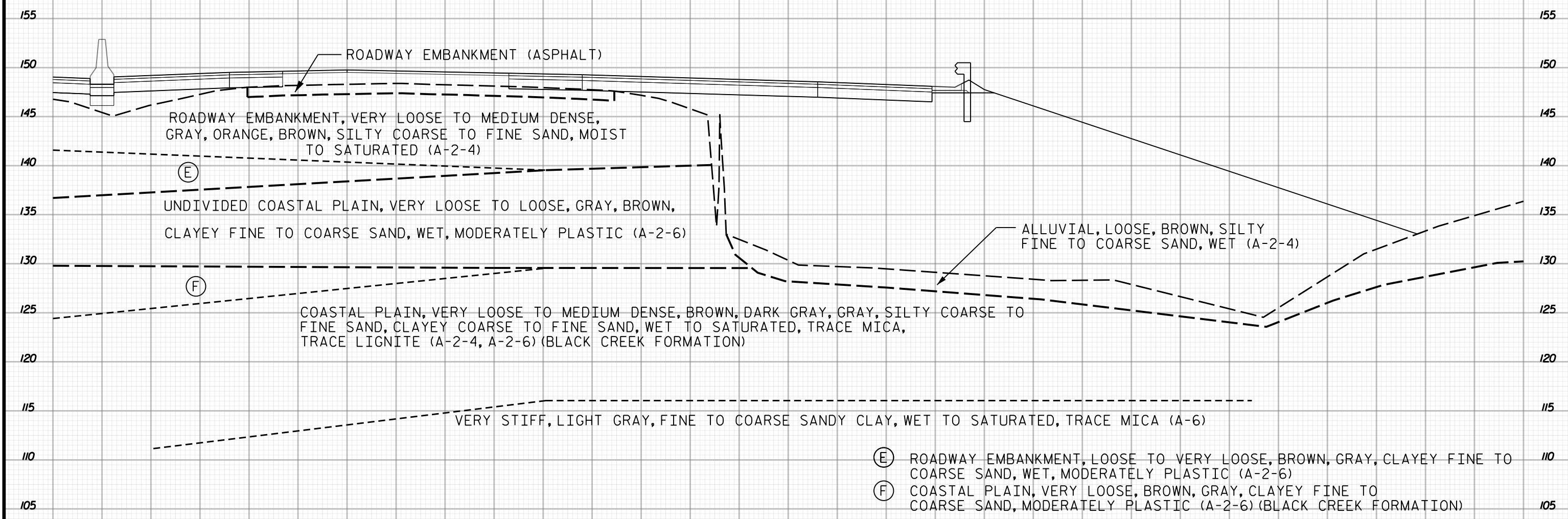

310+50  
2 OF 2

-L-

5 0 5 10 15 20 25 30 35 40 45 50 55 60 65 70 75 80 85 90 95 100 105 110 115 120 125 130 135 140 145

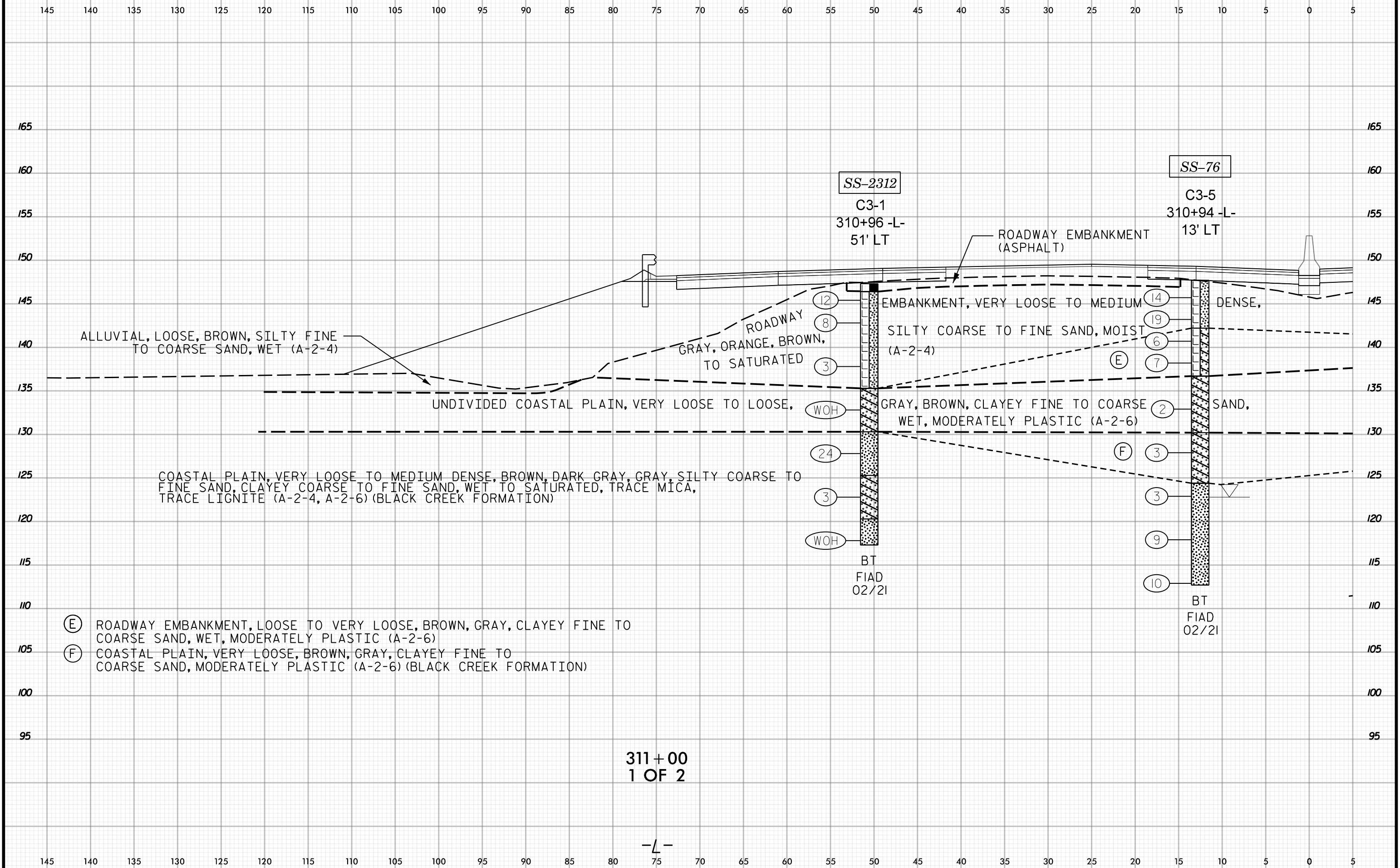
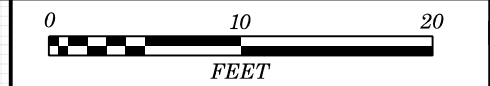

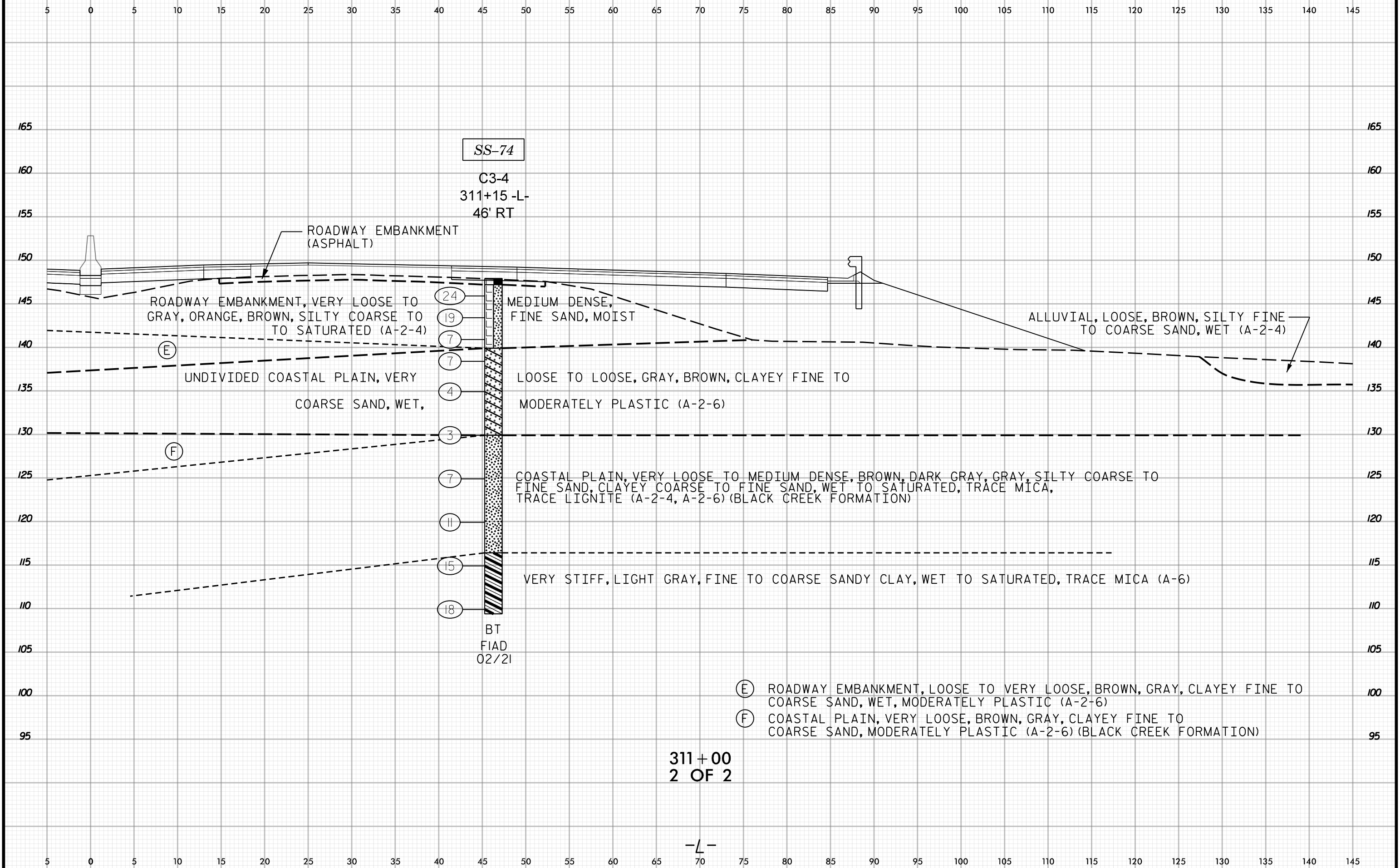

SS-74  
C3-4  
311+15 -L-  
46' RT

ROADWAY EMBANKMENT (ASPHALT)

ROADWAY EMBANKMENT, VERY LOOSE TO GRAY, ORANGE, BROWN, SILTY COARSE TO TO SATURATED (A-2-4)

(E)

UNDIVIDED COASTAL PLAIN, VERY COARSE SAND, WET, MODERATELY PLASTIC (A-2-6)

(F)

MEDIUM DENSE, FINE SAND, MOIST

ALLUVIAL, LOOSE, BROWN, SILTY FINE TO COARSE SAND, WET (A-2-4)

LOOSE TO LOOSE, GRAY, BROWN, CLAYEY FINE TO MODERATELY PLASTIC (A-2-6)

COASTAL PLAIN, VERY LOOSE TO MEDIUM DENSE, BROWN, DARK GRAY, GRAY, SILTY COARSE TO FINE SAND, CLAYEY COARSE TO FINE SAND, WET TO SATURATED, TRACE MICA, TRACE LIGNITE (A-2-4, A-2-6) (BLACK CREEK FORMATION)

VERY STIFF, LIGHT GRAY, FINE TO COARSE SANDY CLAY, WET TO SATURATED, TRACE MICA (A-6)

BT  
FIAD  
02/21

(E) ROADWAY EMBANKMENT, LOOSE TO VERY LOOSE, BROWN, GRAY, CLAYEY FINE TO COARSE SAND, WET, MODERATELY PLASTIC (A-2-6)

(F) COASTAL PLAIN, VERY LOOSE, BROWN, GRAY, CLAYEY FINE TO COARSE SAND, MODERATELY PLASTIC (A-2-6) (BLACK CREEK FORMATION)

311+00  
2 OF 2

-L-

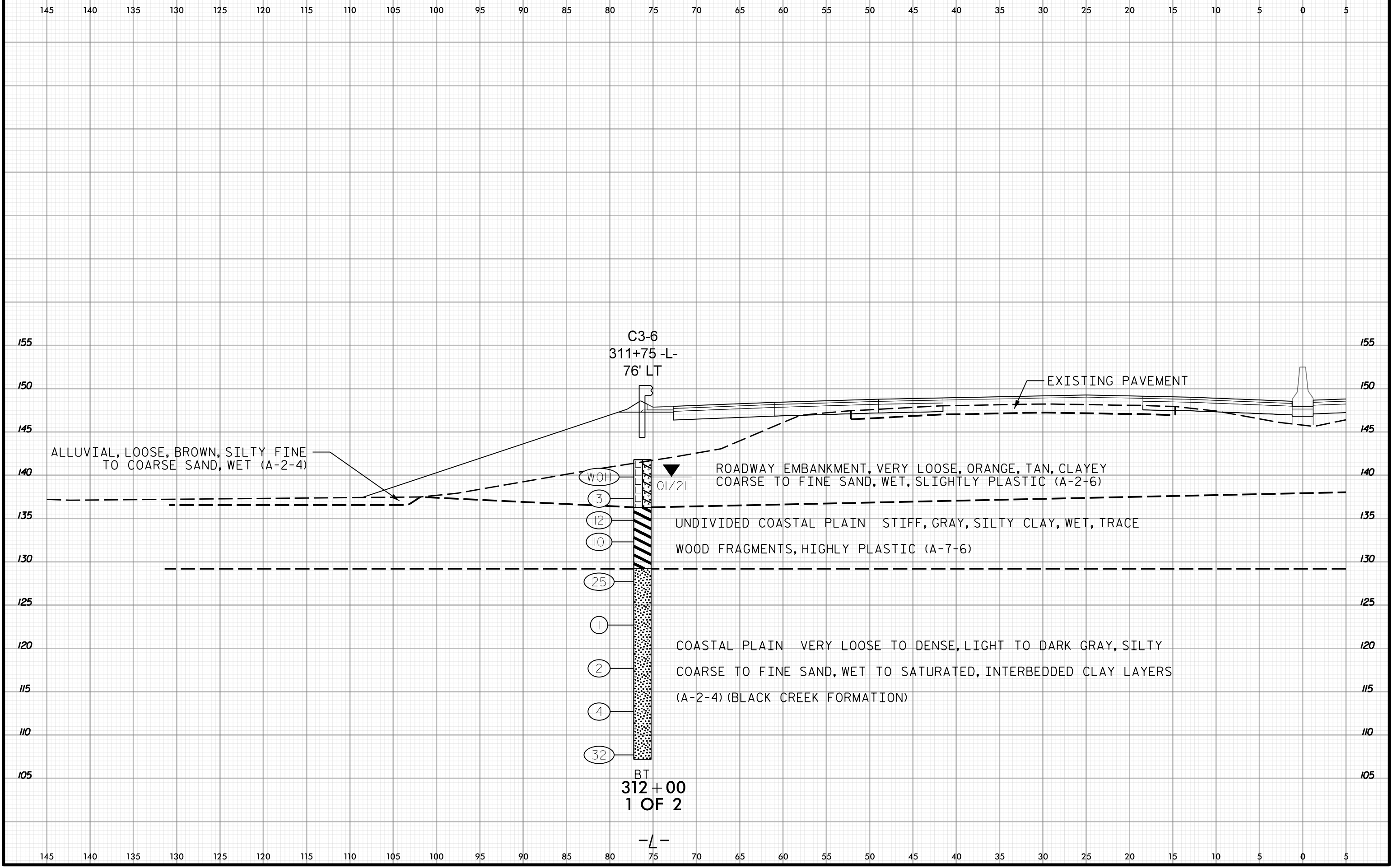

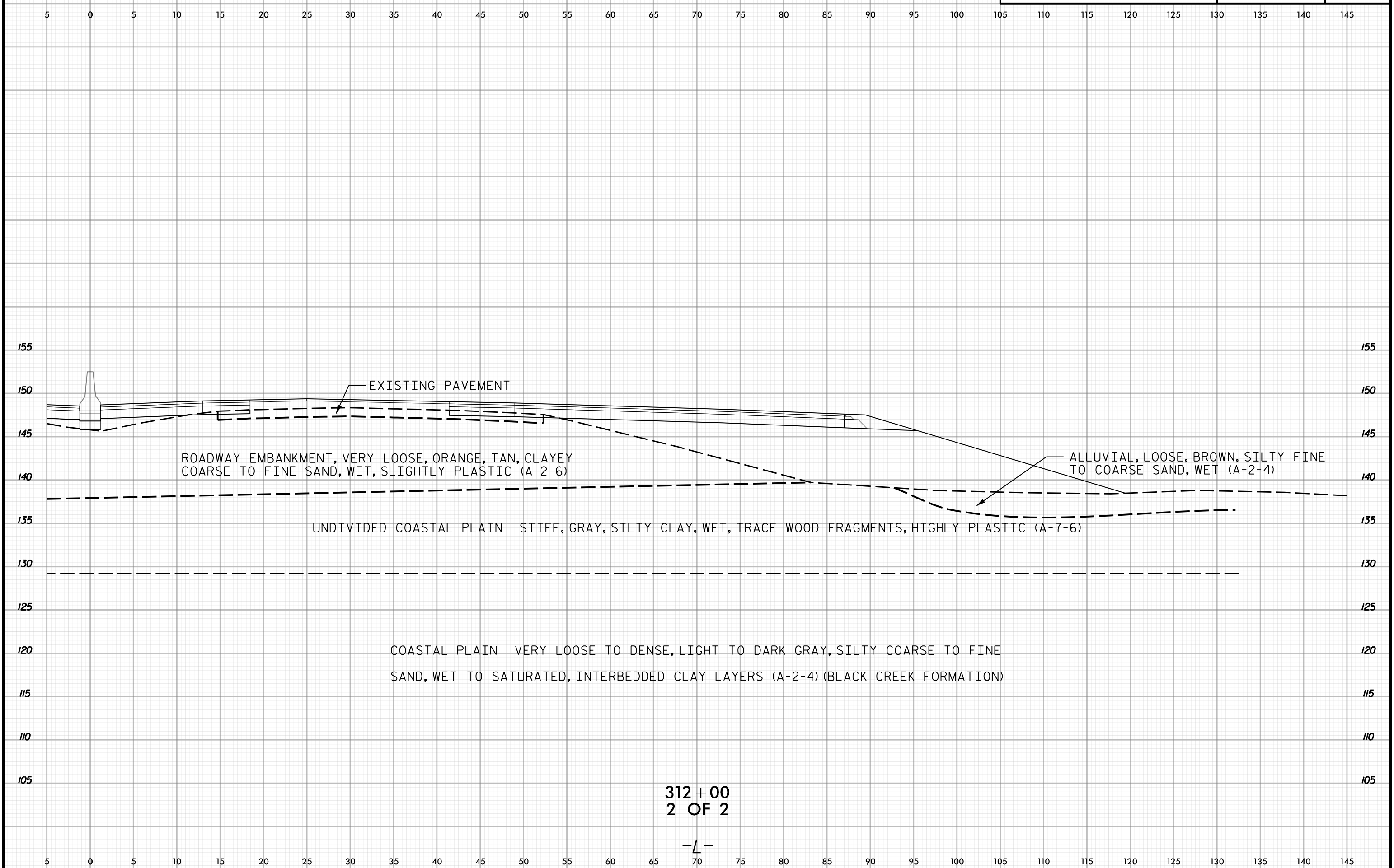

312+00  
2 OF 2

-L-





145 140 135 130 125 120 115 110 105 100 95 90 85 80 75 70 65 60 55 50 45 40 35 30 25 20 15 10 5 0 5

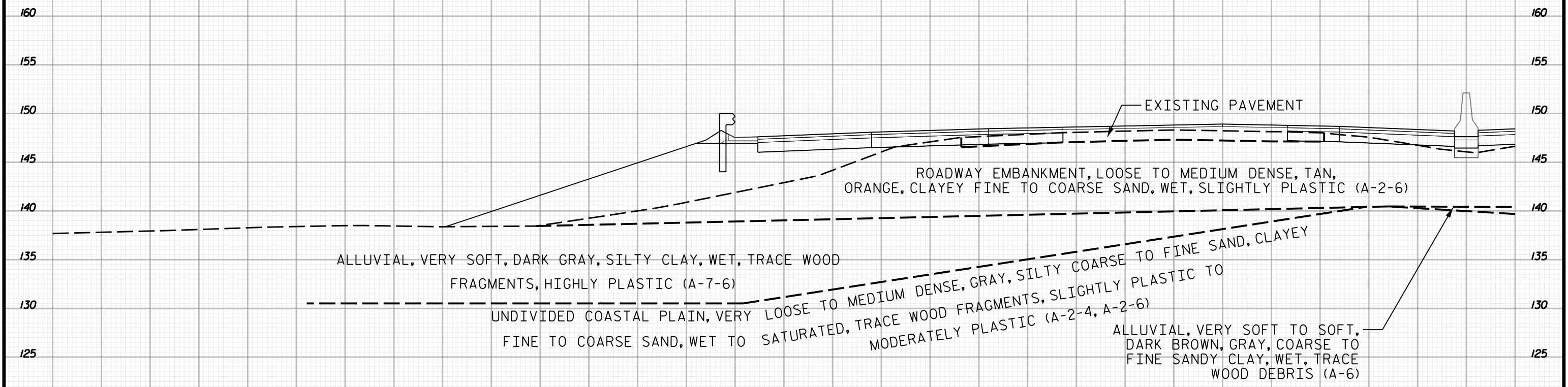

313 + 00

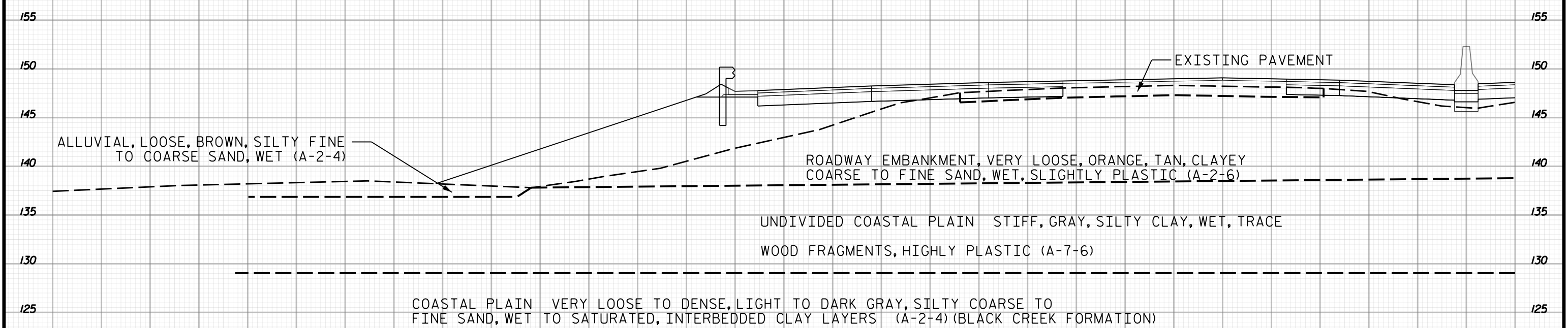

312 + 50  
1 OF 2

-L-

145 140 135 130 125 120 115 110 105 100 95 90 85 80 75 70 65 60 55 50 45 40 35 30 25 20 15 10 5 0 5

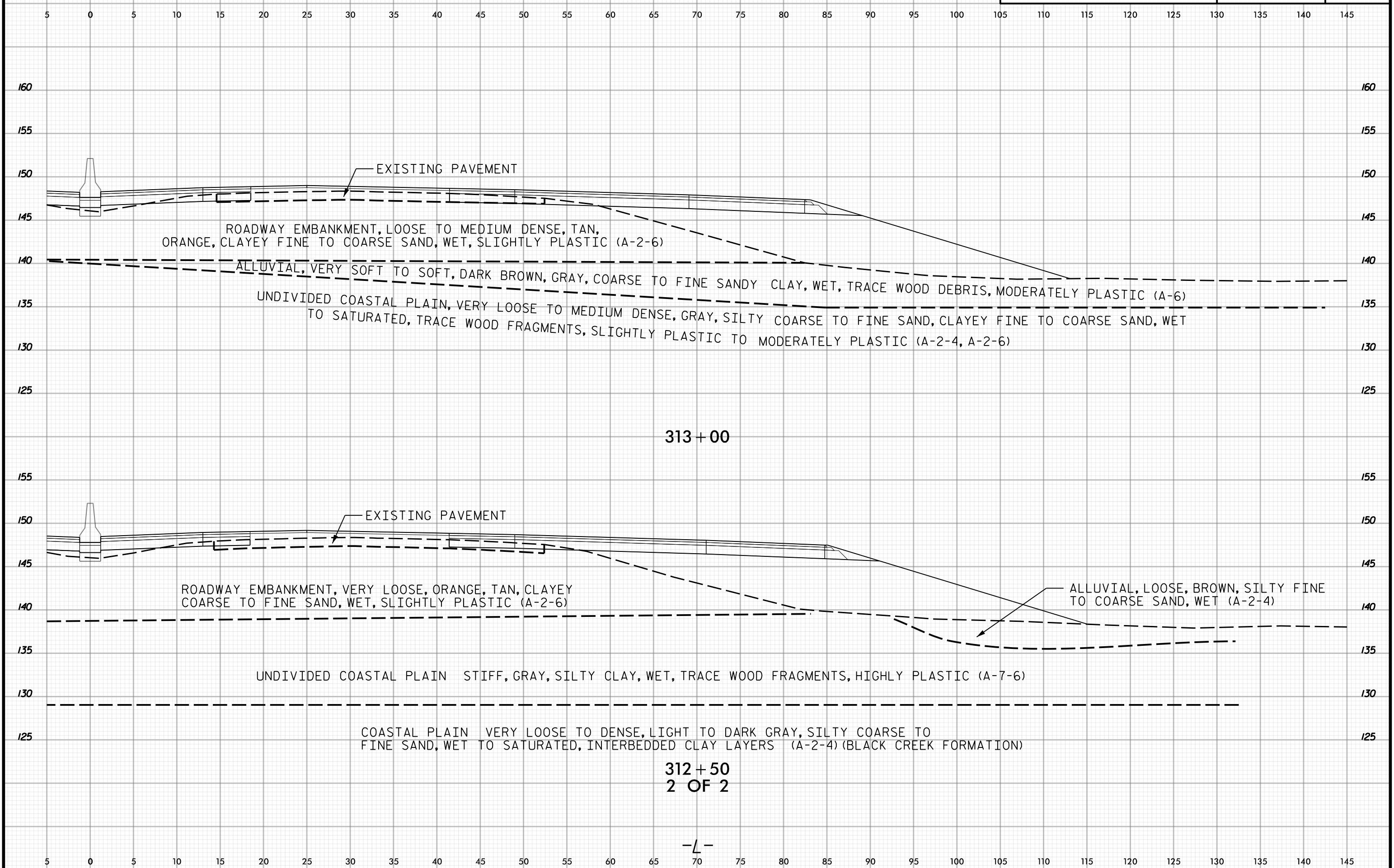

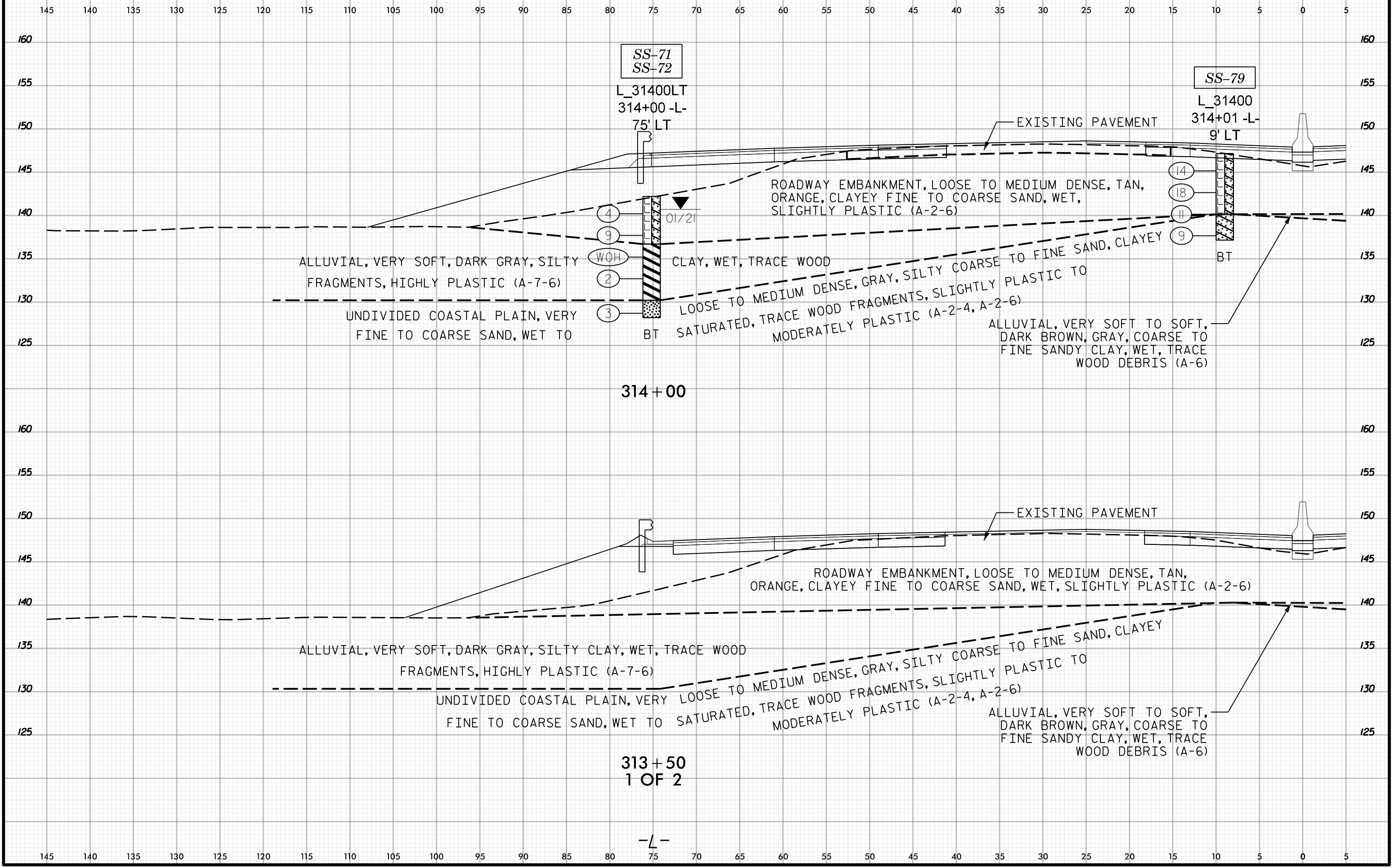
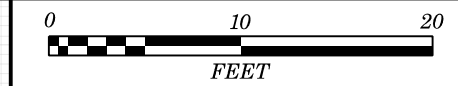

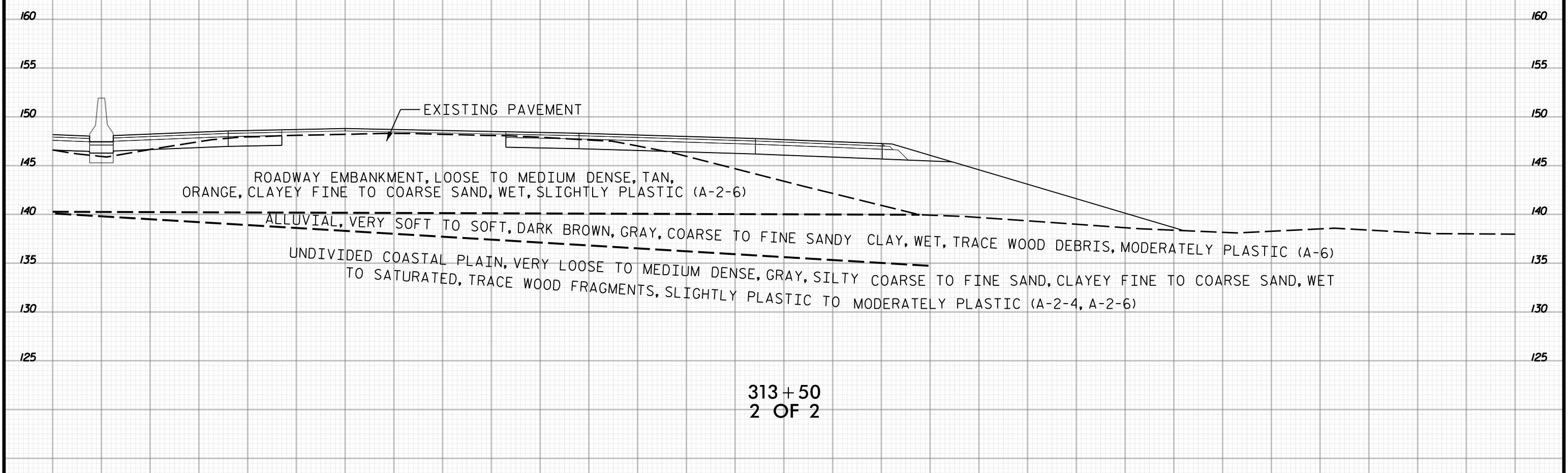
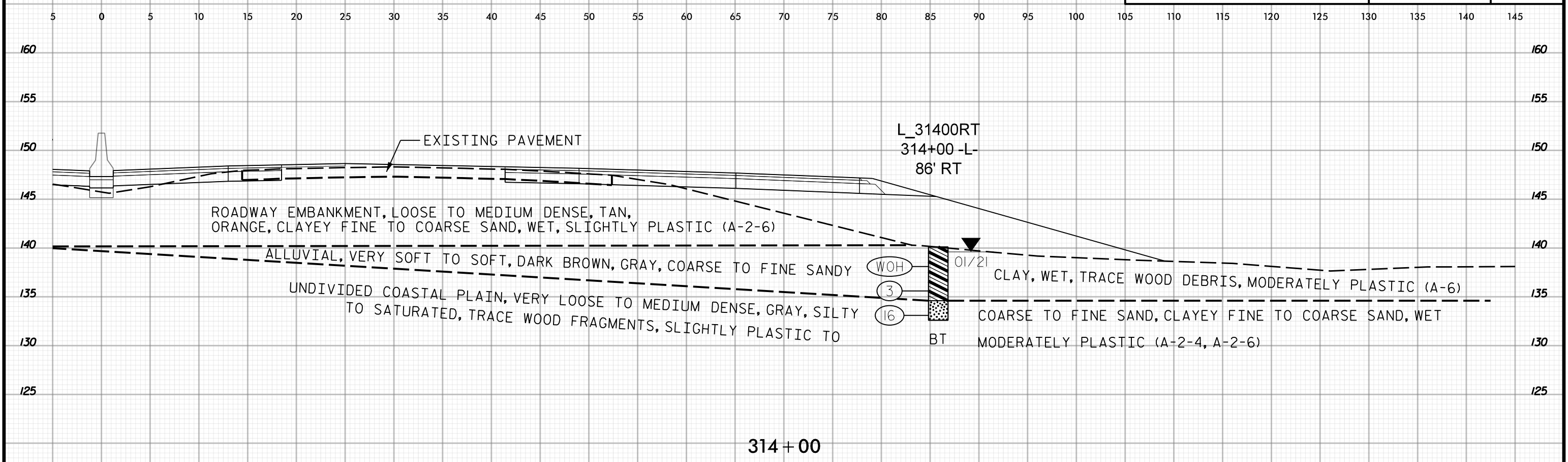

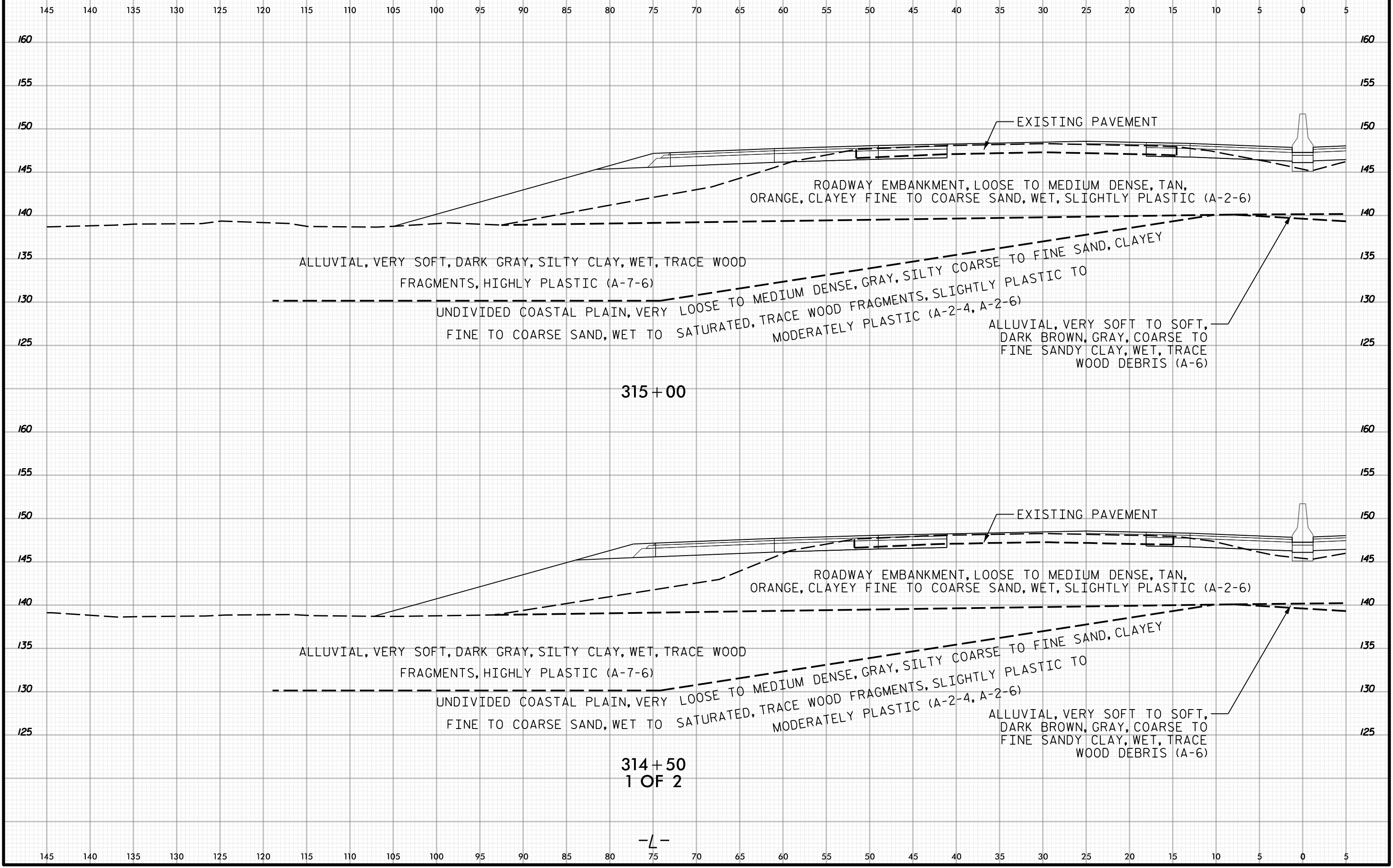

315+00

314+50  
1 OF 2

-L-

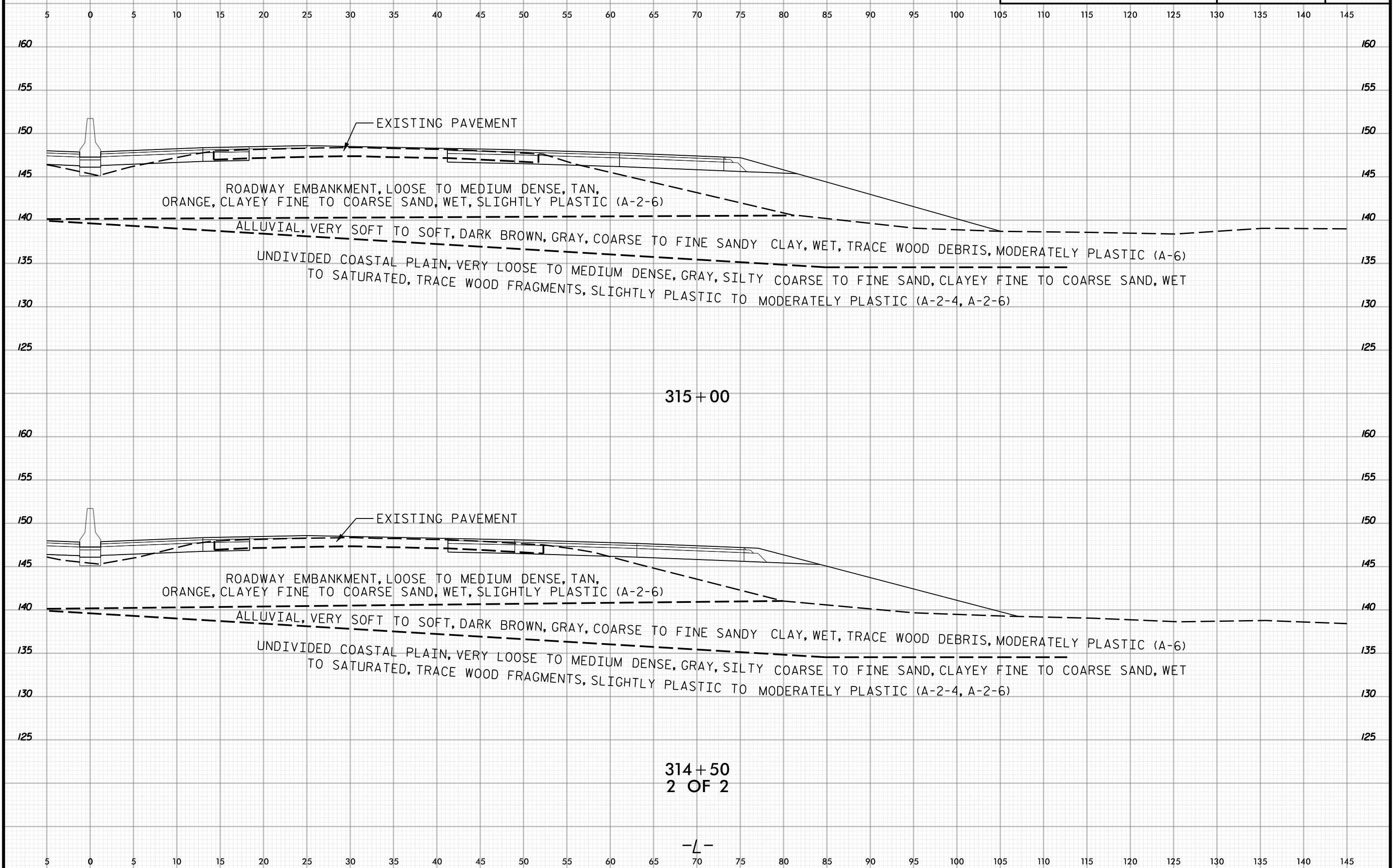

315+00

314+50  
2 OF 2

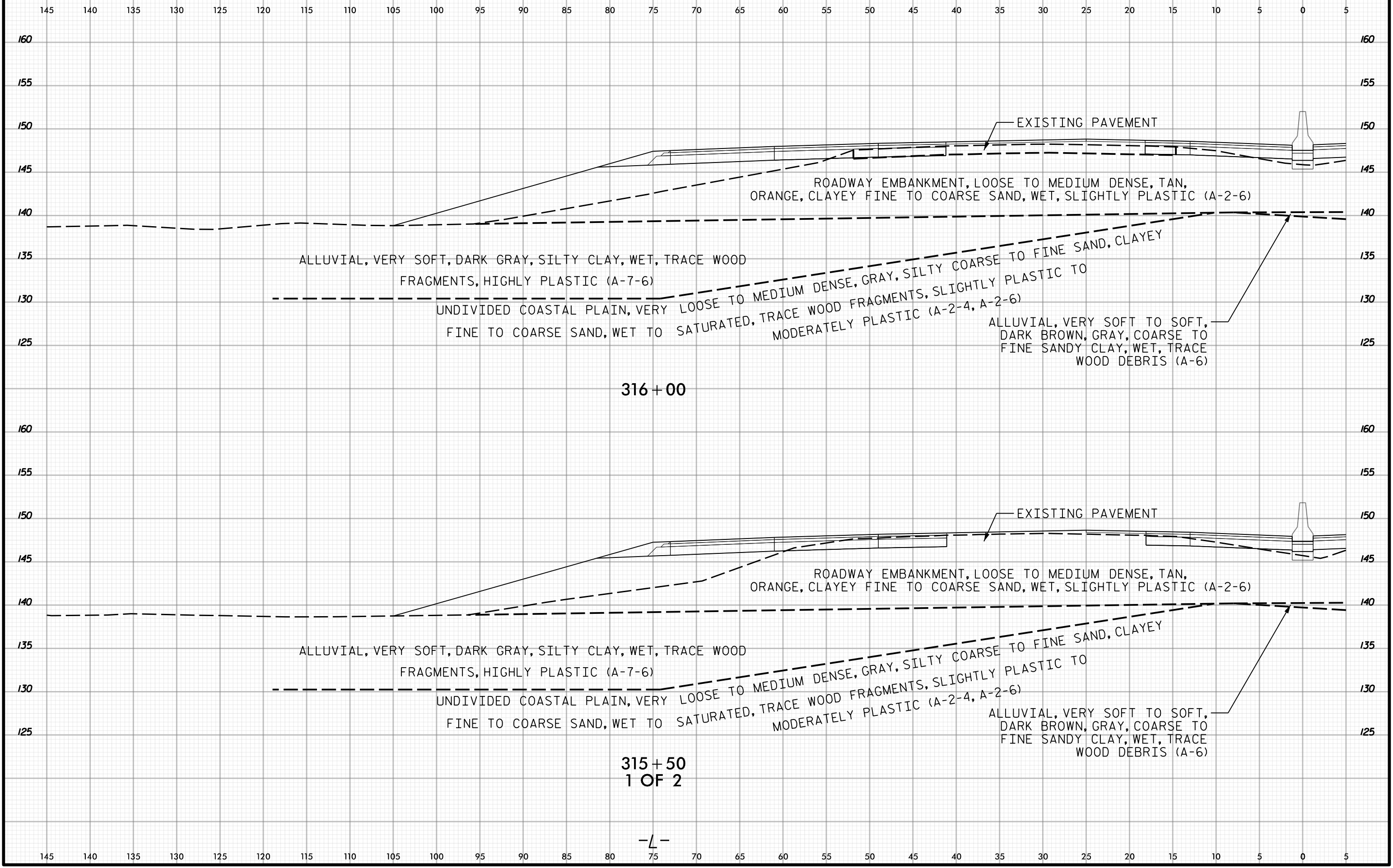

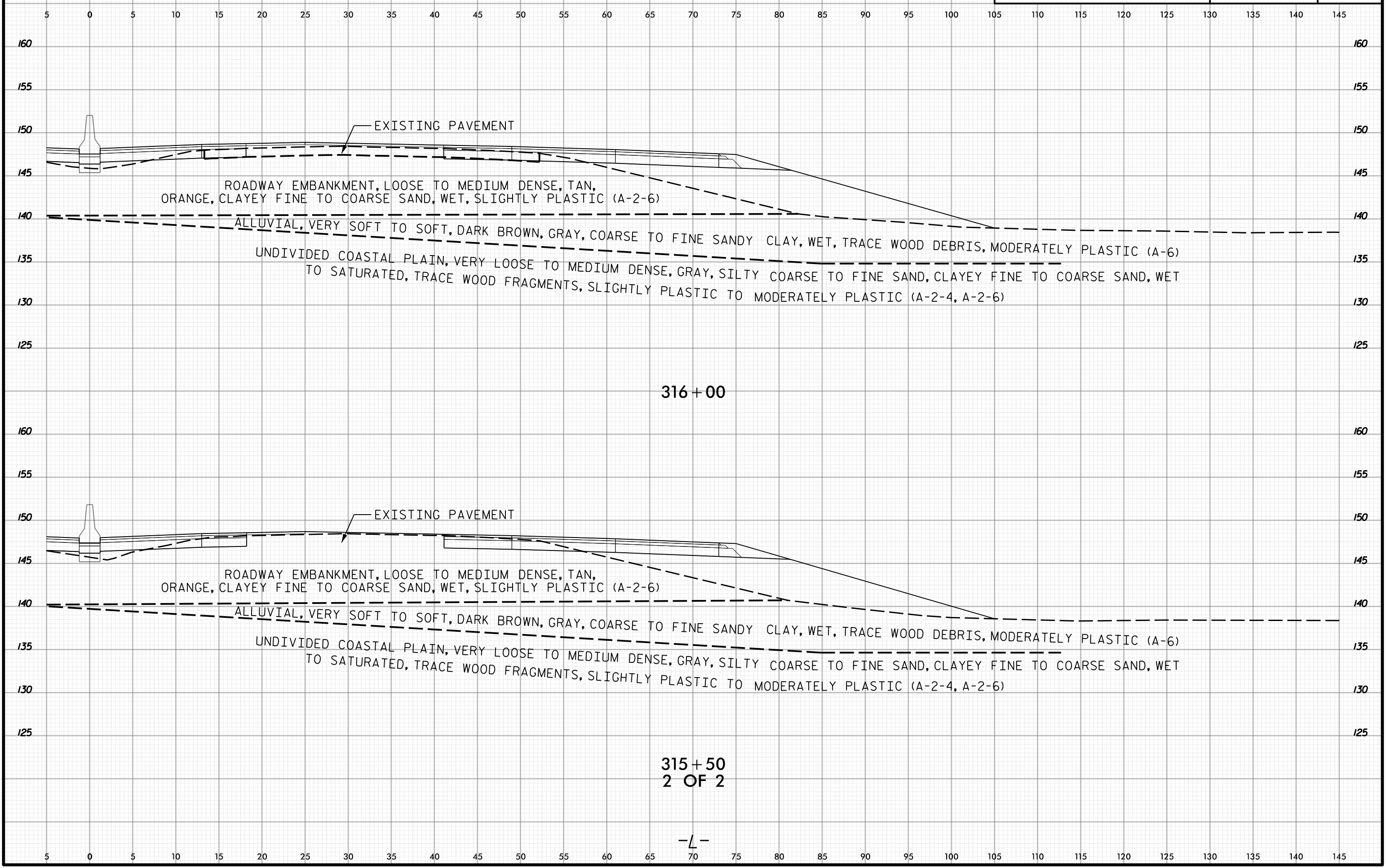

EXISTING PAVEMENT

ROADWAY EMBANKMENT, LOOSE TO MEDIUM DENSE, TAN, ORANGE, CLAYEY FINE TO COARSE SAND, WET, SLIGHTLY PLASTIC (A-2-6)

ALLUVIAL, VERY SOFT TO SOFT, DARK BROWN, GRAY, COARSE TO FINE SANDY CLAY, WET, TRACE WOOD DEBRIS, MODERATELY PLASTIC (A-6)

UNDIVIDED COASTAL PLAIN, VERY LOOSE TO MEDIUM DENSE, GRAY, SILTY COARSE TO FINE SAND, CLAYEY FINE TO COARSE SAND, WET TO SATURATED, TRACE WOOD FRAGMENTS, SLIGHTLY PLASTIC TO MODERATELY PLASTIC (A-2-4, A-2-6)

316+00

EXISTING PAVEMENT

ROADWAY EMBANKMENT, LOOSE TO MEDIUM DENSE, TAN, ORANGE, CLAYEY FINE TO COARSE SAND, WET, SLIGHTLY PLASTIC (A-2-6)

ALLUVIAL, VERY SOFT TO SOFT, DARK BROWN, GRAY, COARSE TO FINE SANDY CLAY, WET, TRACE WOOD DEBRIS, MODERATELY PLASTIC (A-6)

UNDIVIDED COASTAL PLAIN, VERY LOOSE TO MEDIUM DENSE, GRAY, SILTY COARSE TO FINE SAND, CLAYEY FINE TO COARSE SAND, WET TO SATURATED, TRACE WOOD FRAGMENTS, SLIGHTLY PLASTIC TO MODERATELY PLASTIC (A-2-4, A-2-6)

315+50  
2 OF 2



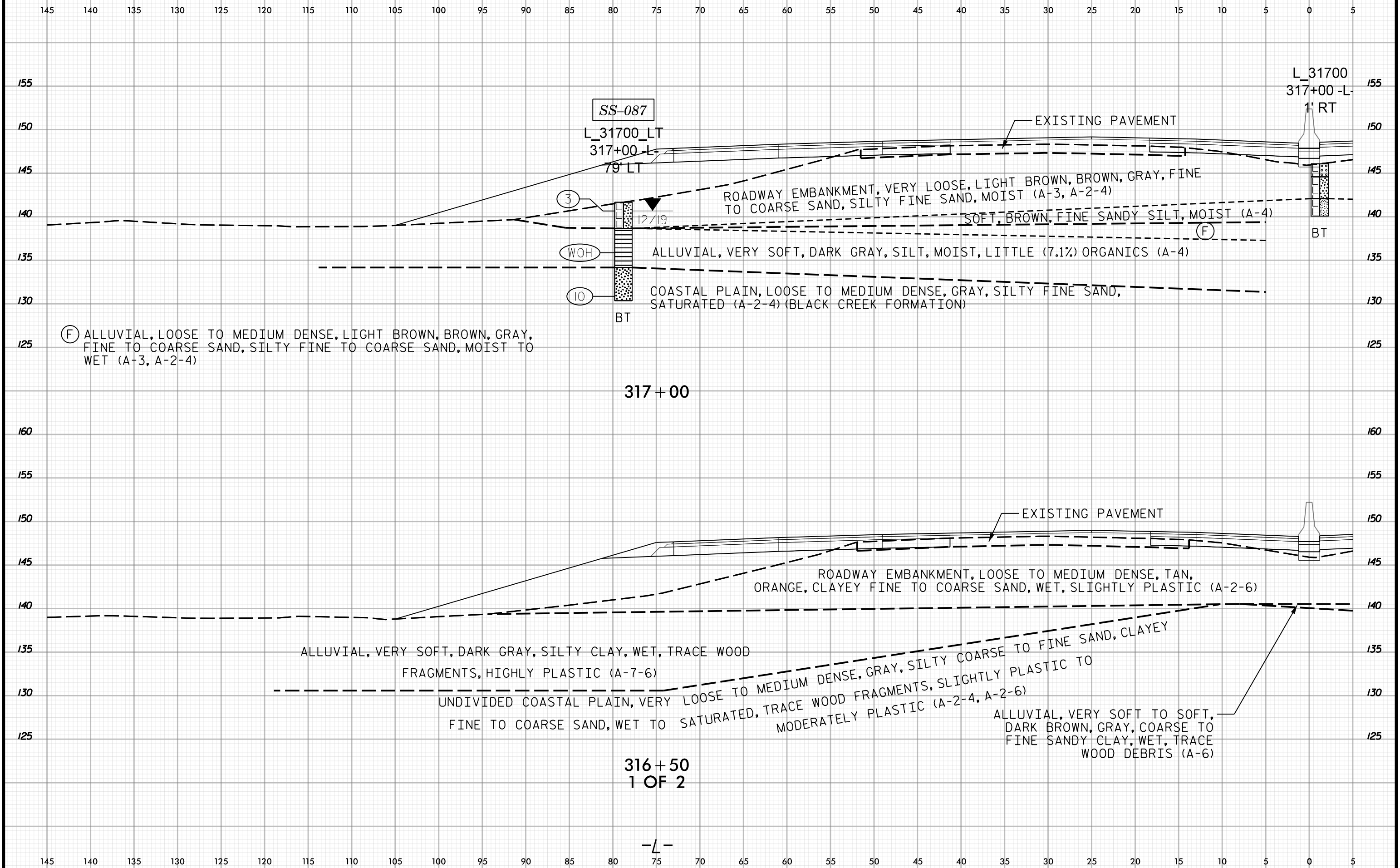
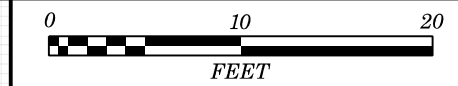

SS-087

L\_31700\_LT  
317+00-L

79' LT

3

12/19

WOH

10

BT

L\_31700  
317+00-L

1' RT

BT

EXISTING PAVEMENT

ROADWAY EMBANKMENT, VERY LOOSE, LIGHT BROWN, BROWN, GRAY, FINE TO COARSE SAND, SILTY FINE SAND, MOIST (A-3, A-2-4)

SOFT, BROWN, FINE SANDY SILT, MOIST (A-4)

ALLUVIAL, VERY SOFT, DARK GRAY, SILT, MOIST, LITTLE (7.1%) ORGANICS (A-4)

COASTAL PLAIN, LOOSE TO MEDIUM DENSE, GRAY, SILTY FINE SAND, SATURATED (A-2-4) (BLACK CREEK FORMATION)

(F) ALLUVIAL, LOOSE TO MEDIUM DENSE, LIGHT BROWN, BROWN, GRAY, FINE TO COARSE SAND, SILTY FINE TO COARSE SAND, MOIST TO WET (A-3, A-2-4)

317+00

EXISTING PAVEMENT

ROADWAY EMBANKMENT, LOOSE TO MEDIUM DENSE, TAN, ORANGE, CLAYEY FINE TO COARSE SAND, WET, SLIGHTLY PLASTIC (A-2-6)

ALLUVIAL, VERY SOFT, DARK GRAY, SILTY CLAY, WET, TRACE WOOD FRAGMENTS, HIGHLY PLASTIC (A-7-6)

UNDIVIDED COASTAL PLAIN, VERY LOOSE TO MEDIUM DENSE, GRAY, SILTY COARSE TO FINE SAND, CLAYEY FINE TO COARSE SAND, WET TO SATURATED, TRACE WOOD FRAGMENTS, SLIGHTLY PLASTIC TO MODERATELY PLASTIC (A-2-4, A-2-6)

ALLUVIAL, VERY SOFT TO SOFT, DARK BROWN, GRAY, COARSE TO FINE SANDY CLAY, WET, TRACE WOOD DEBRIS (A-6)

316+50  
1 OF 2

-L-

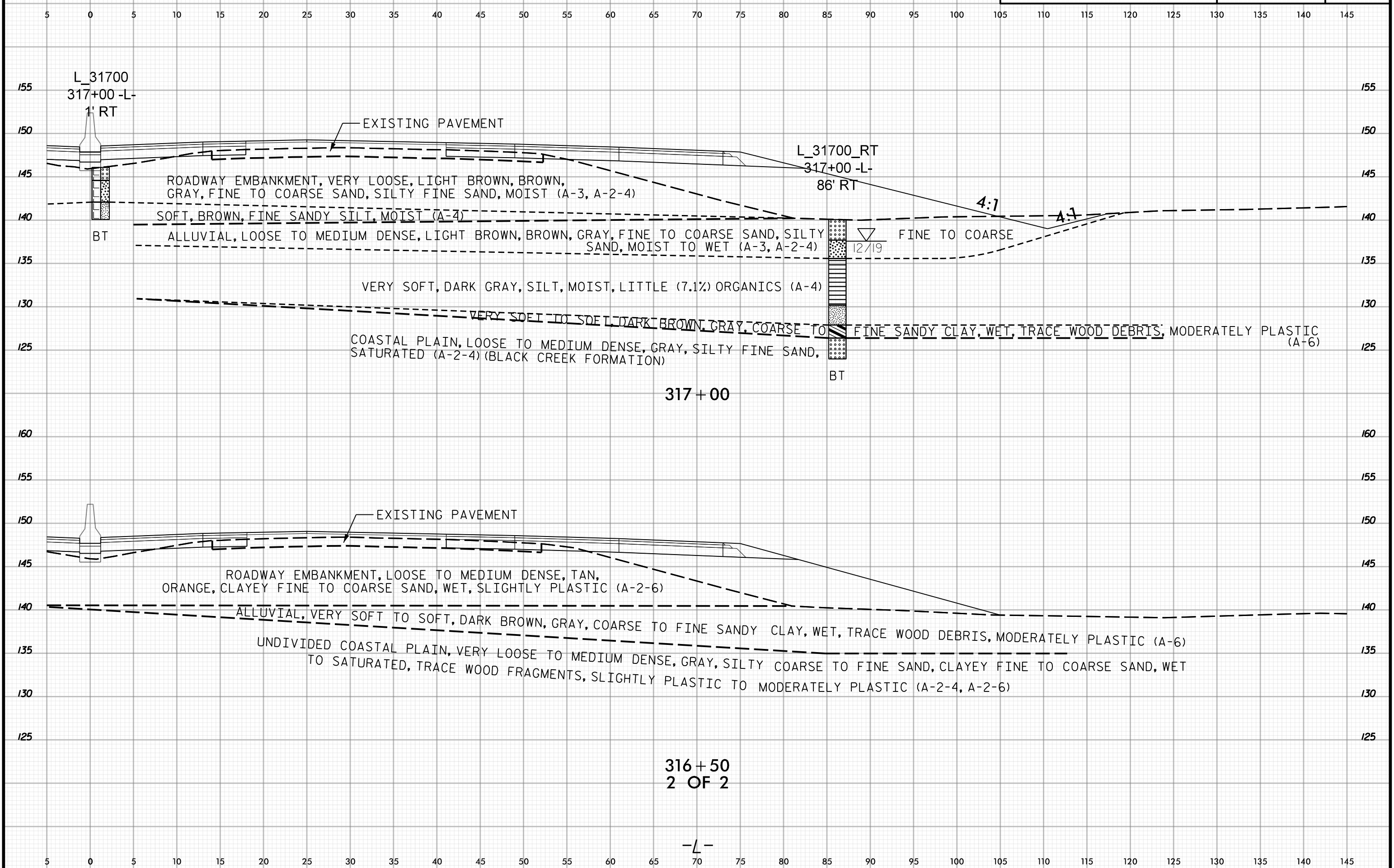
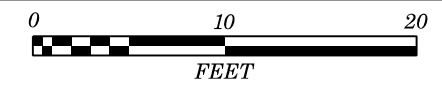



145 140 135 130 125 120 115 110 105 100 95 90 85 80 75 70 65 60 55 50 45 40 35 30 25 20 15 10 5 0 5

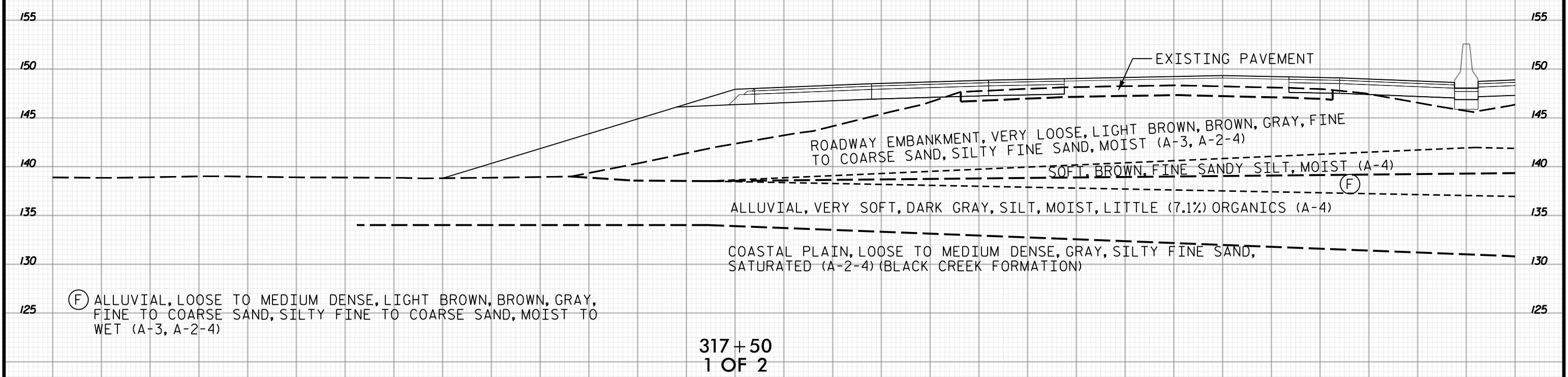
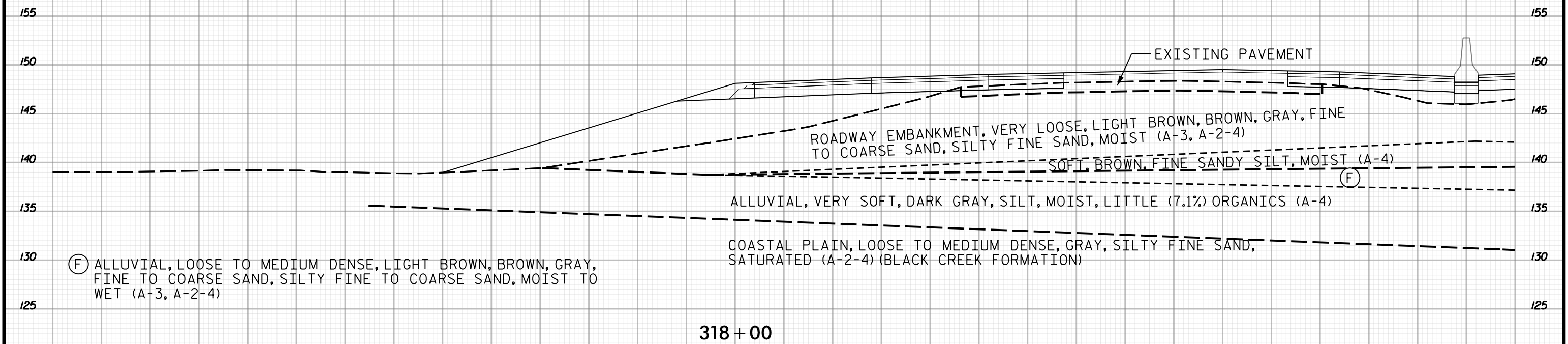

145 140 135 130 125 120 115 110 105 100 95 90 85 80 75 70 65 60 55 50 45 40 35 30 25 20 15 10 5 0 5

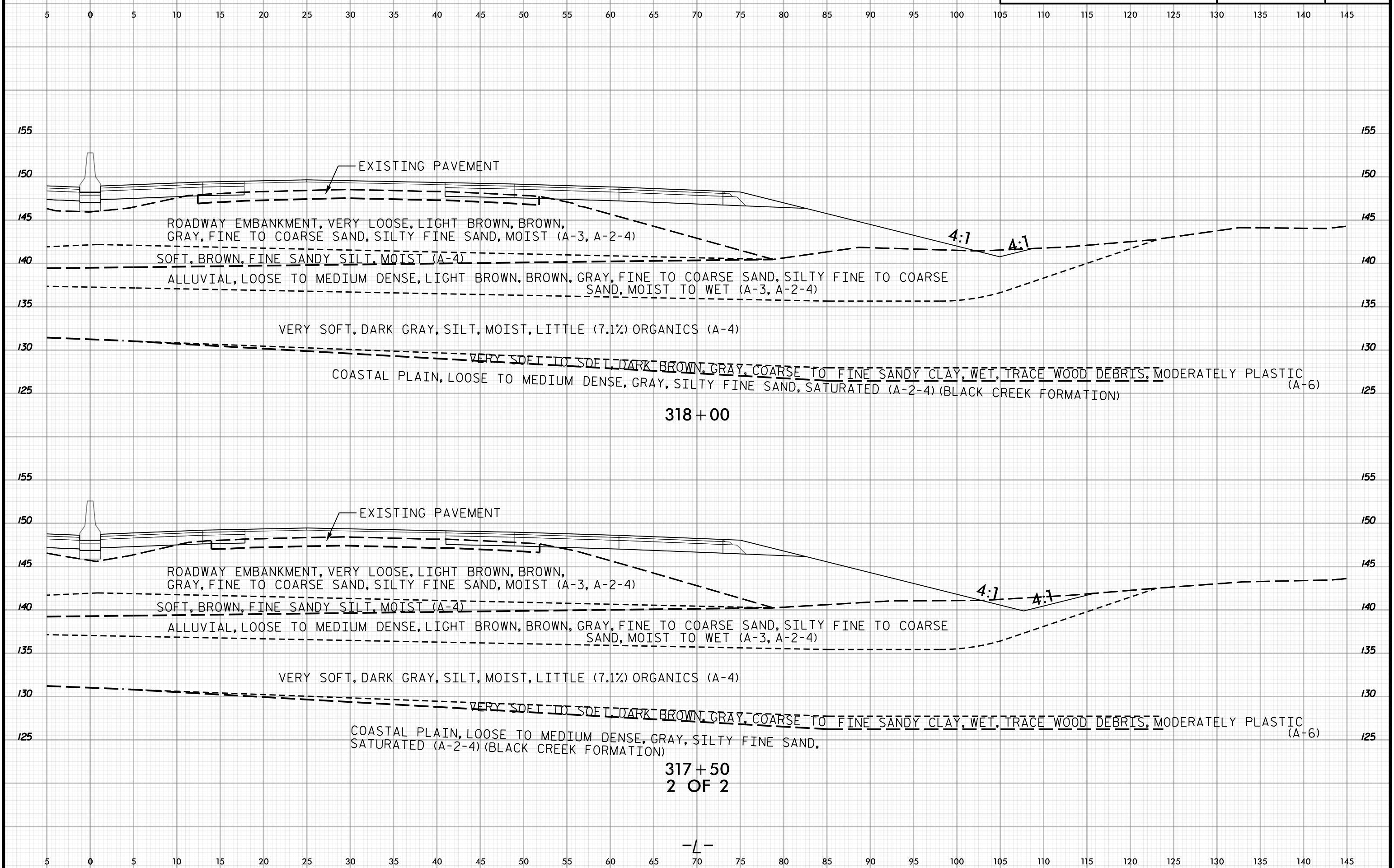

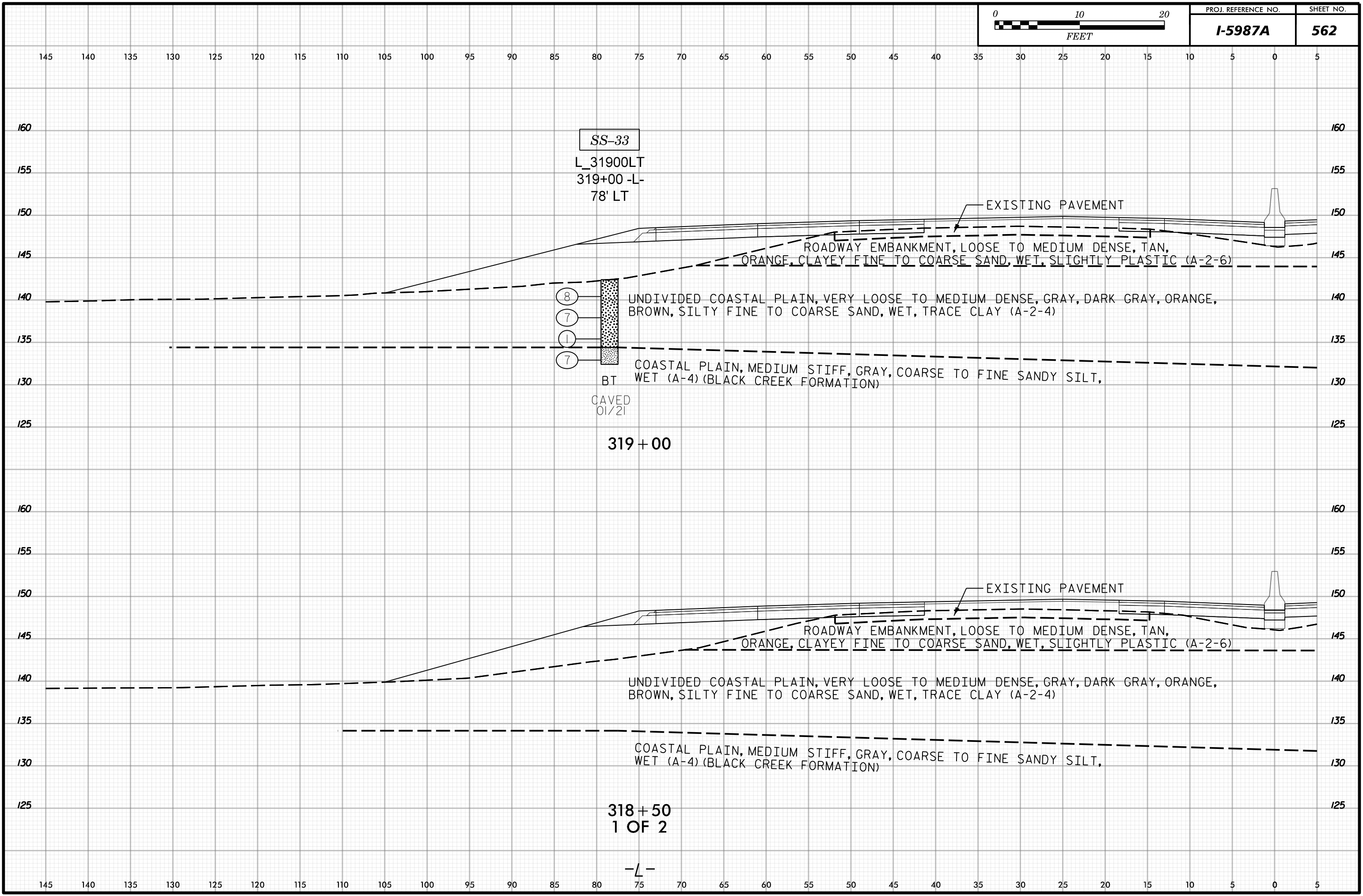
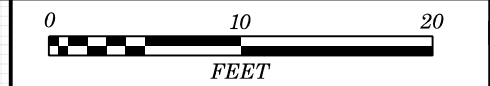

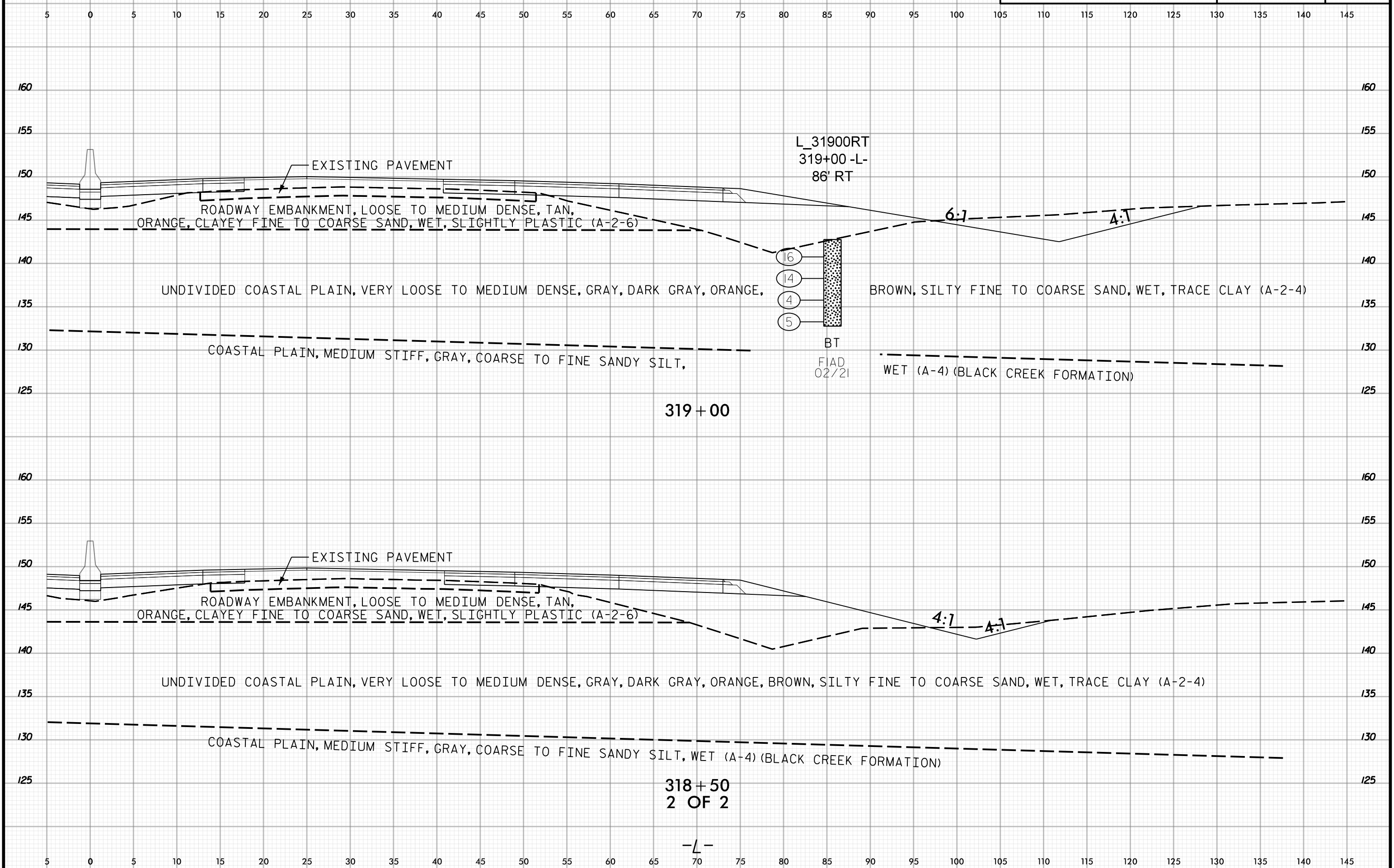

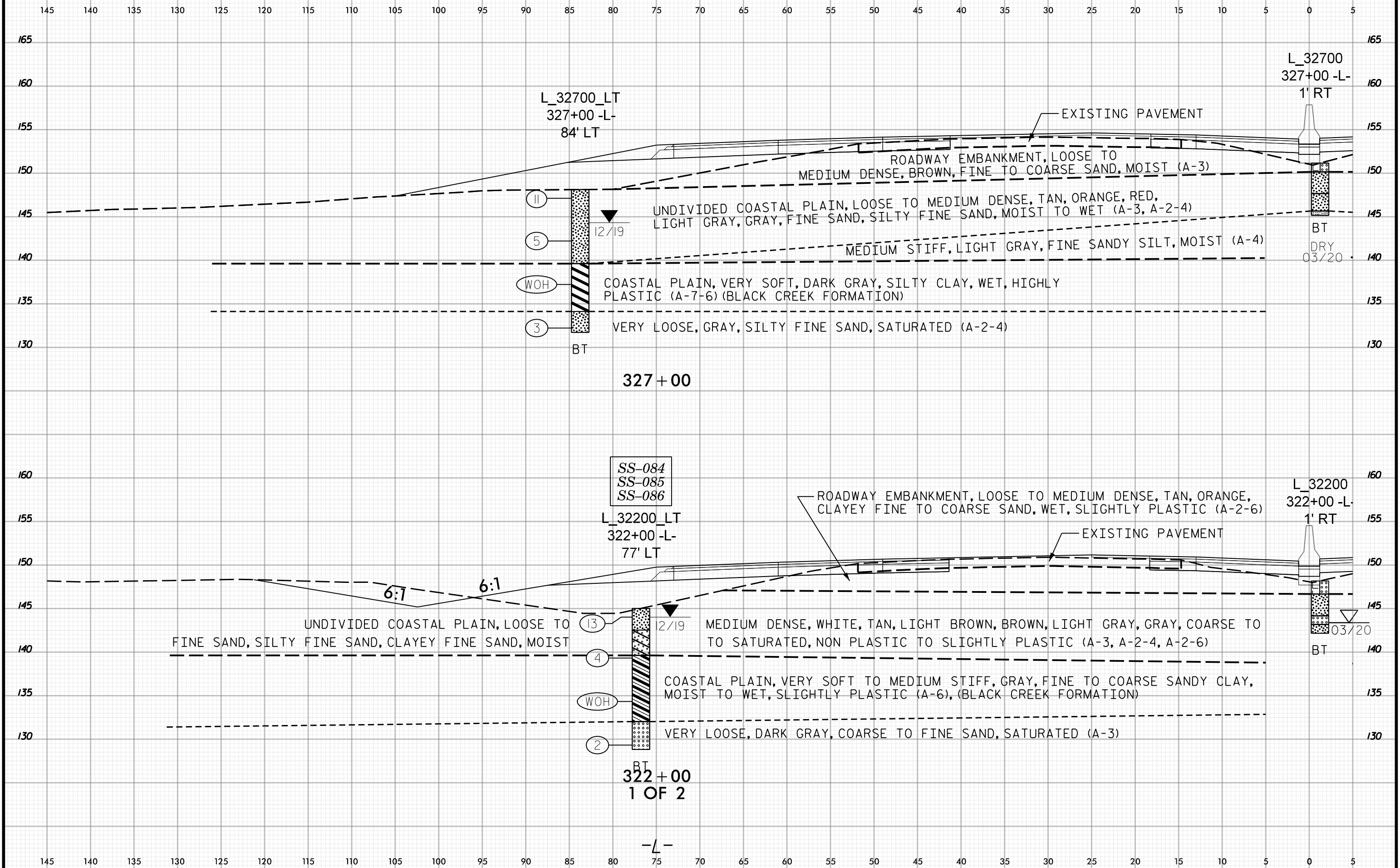
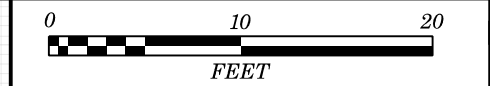

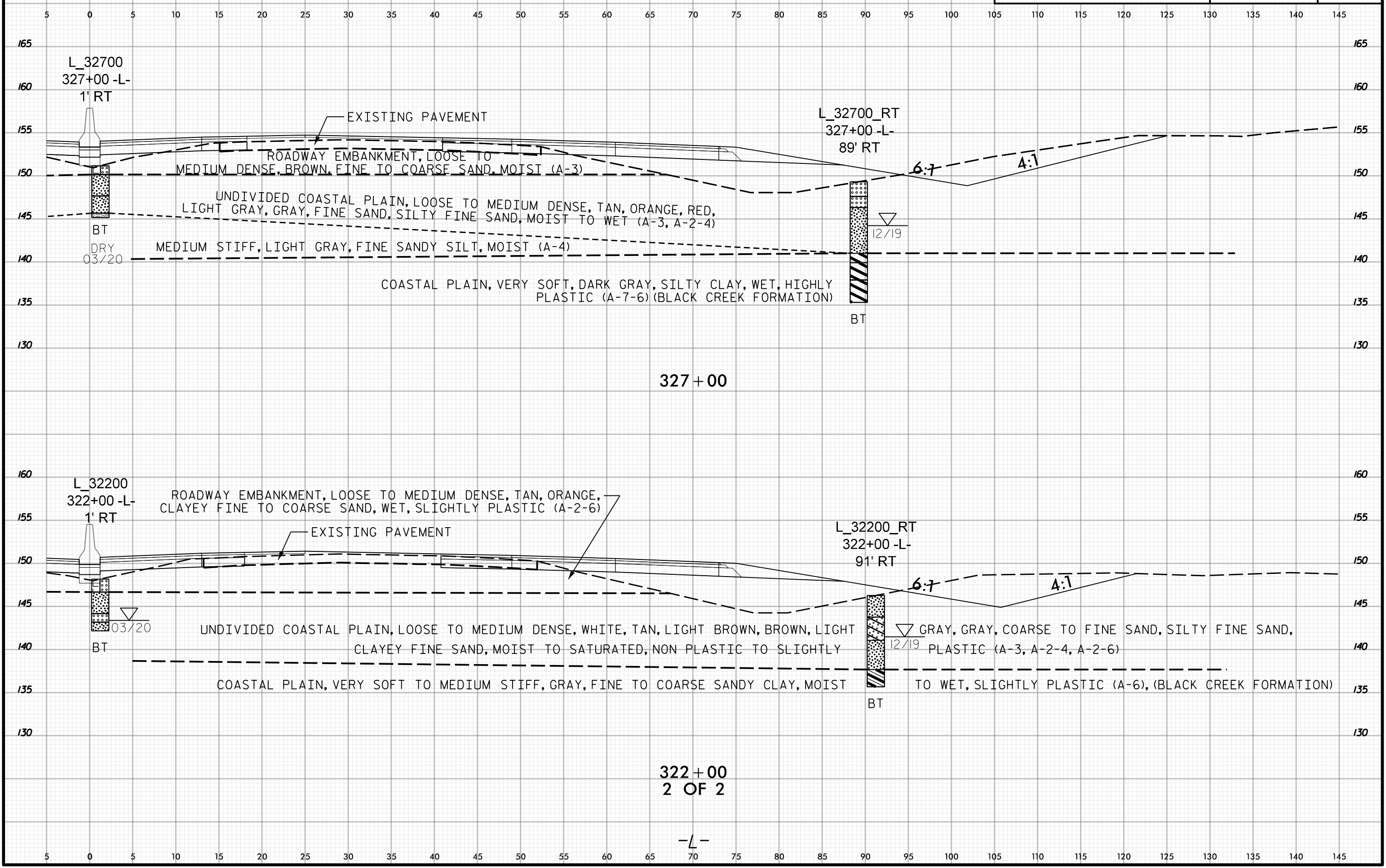
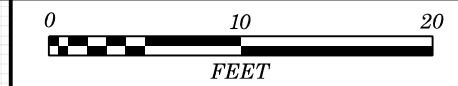

327+00

322+00  
2 OF 2

-L-



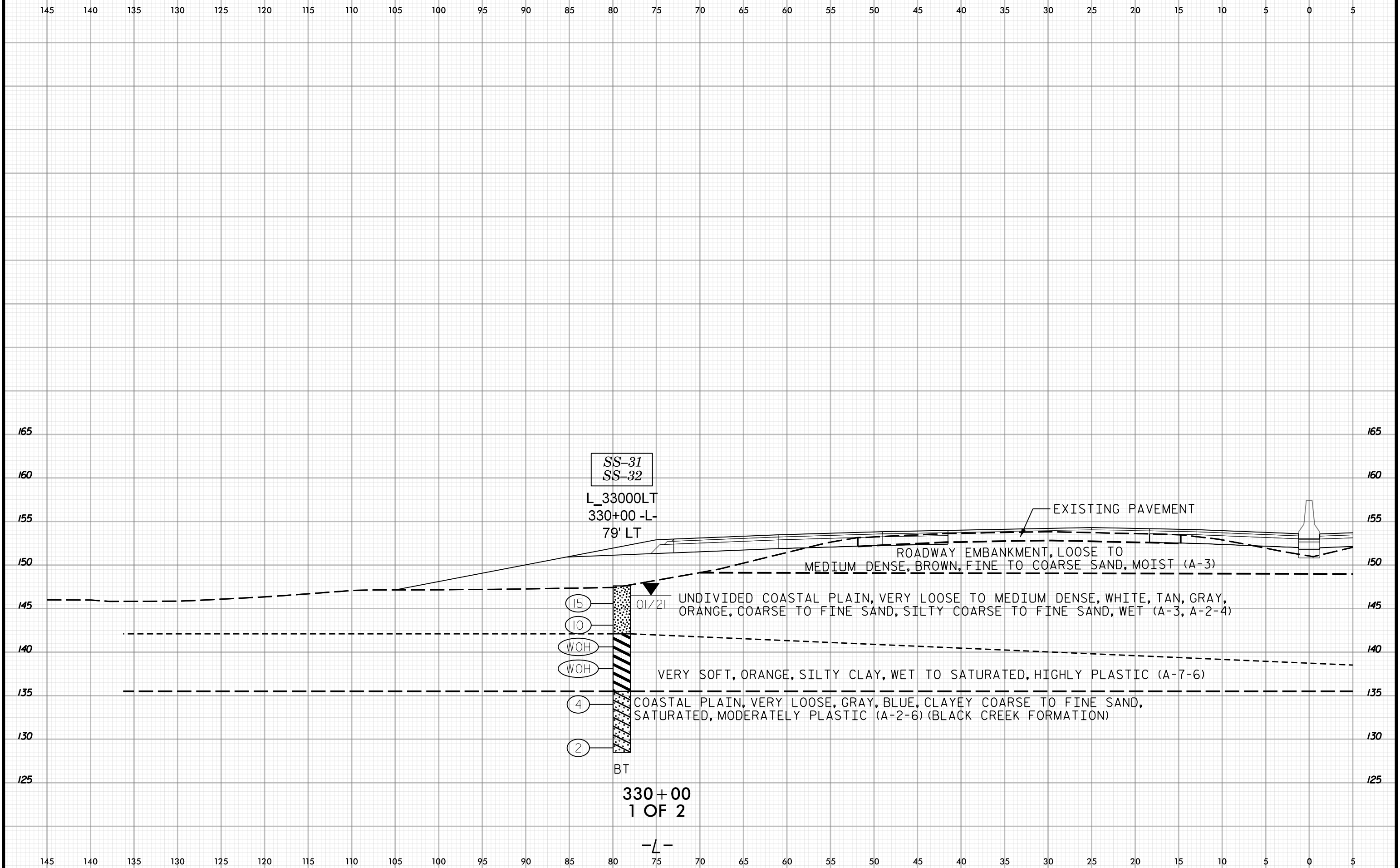

SS-31  
SS-32  
L\_33000LT  
330+00 -L-  
79' LT

EXISTING PAVEMENT

ROADWAY EMBANKMENT, LOOSE TO MEDIUM DENSE, BROWN, FINE TO COARSE SAND, MOIST (A-3)

UNDIVIDED COASTAL PLAIN, VERY LOOSE TO MEDIUM DENSE, WHITE, TAN, GRAY, ORANGE, COARSE TO FINE SAND, SILTY COARSE TO FINE SAND, WET (A-3, A-2-4)

VERY SOFT, ORANGE, SILTY CLAY, WET TO SATURATED, HIGHLY PLASTIC (A-7-6)

COASTAL PLAIN, VERY LOOSE, GRAY, BLUE, CLAYEY COARSE TO FINE SAND, SATURATED, MODERATELY PLASTIC (A-2-6) (BLACK CREEK FORMATION)

- (15)
- (10)
- WOH
- WOH
- (4)
- (2)

BT

330+00  
1 OF 2

-L-



5 0 5 10 15 20 25 30 35 40 45 50 55 60 65 70 75 80 85 90 95 100 105 110 115 120 125 130 135 140 145

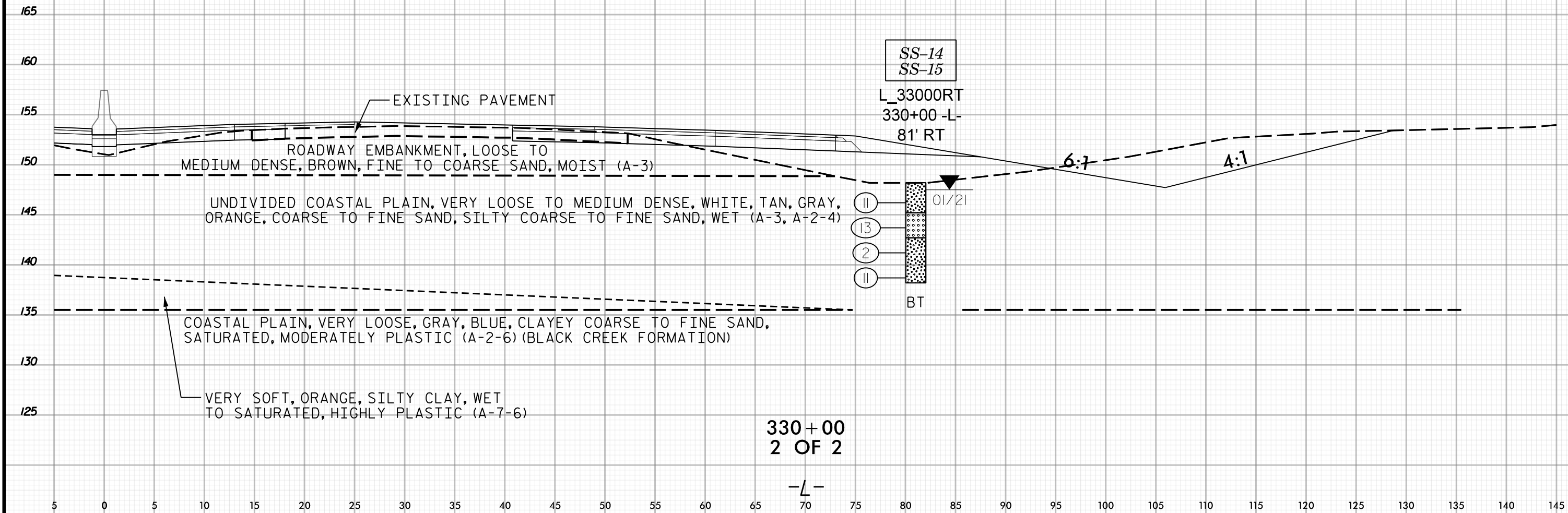

330+00  
2 OF 2

-L-

5 0 5 10 15 20 25 30 35 40 45 50 55 60 65 70 75 80 85 90 95 100 105 110 115 120 125 130 135 140 145

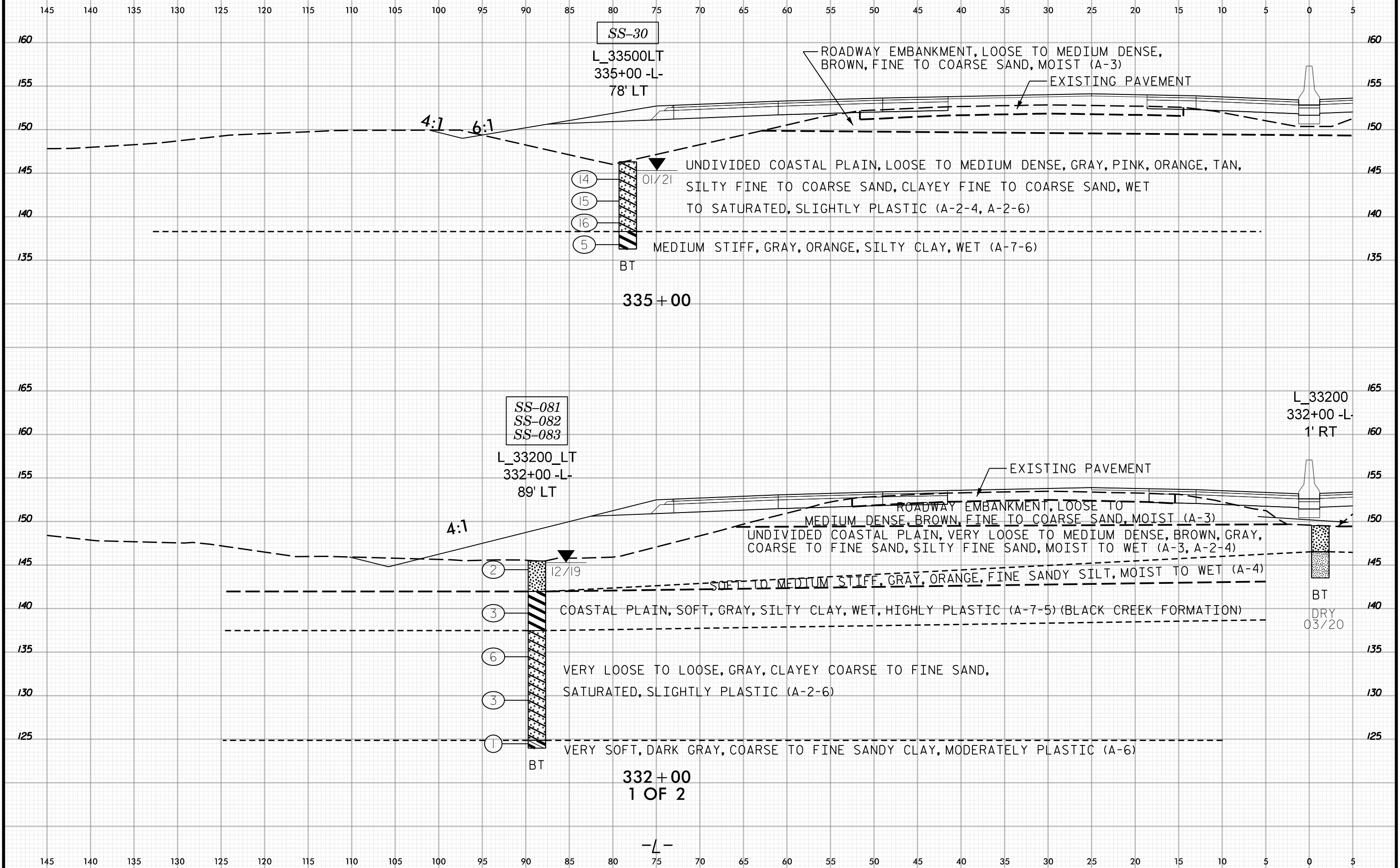

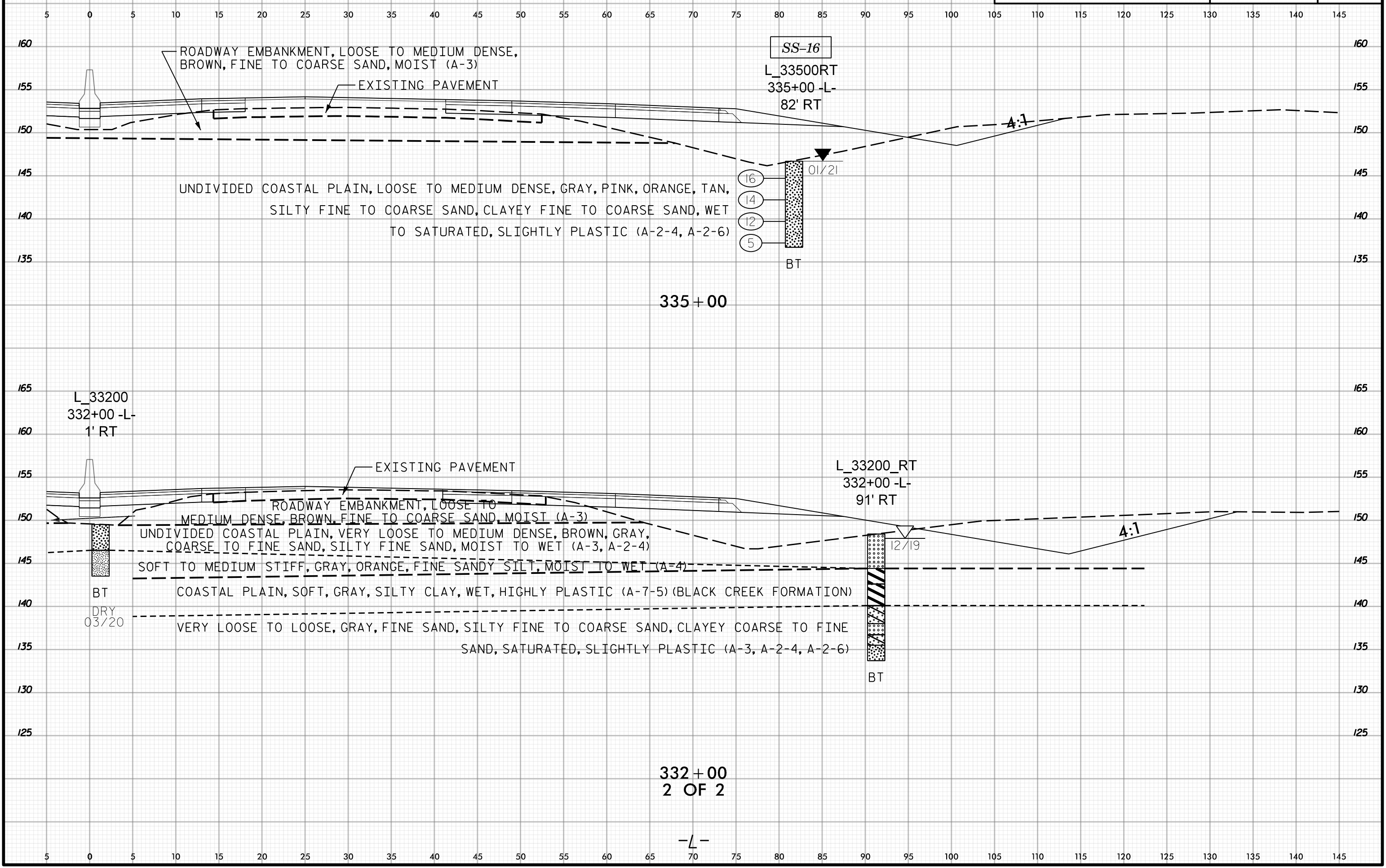
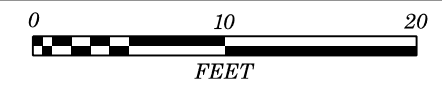

332+00  
2 OF 2

-L-

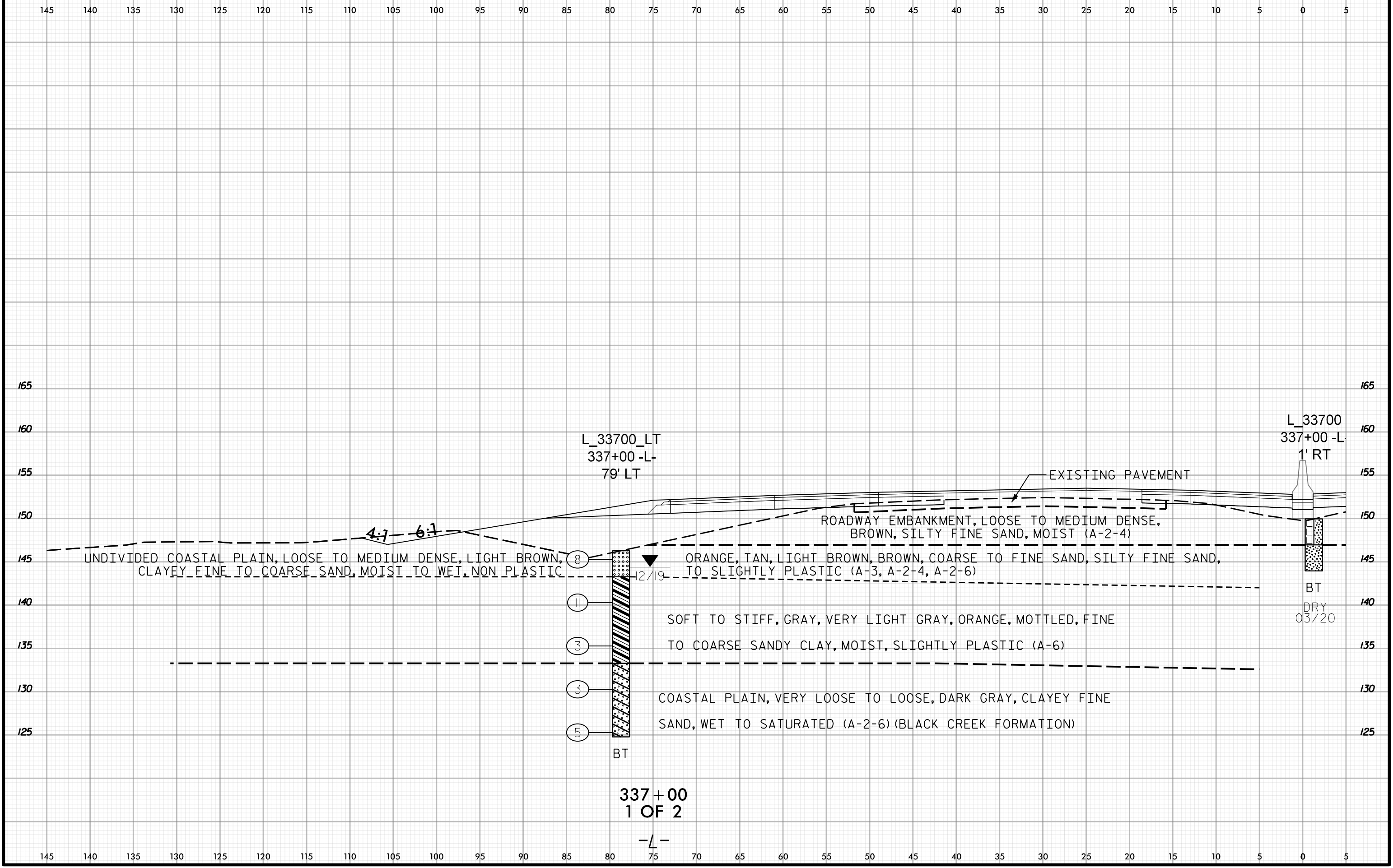
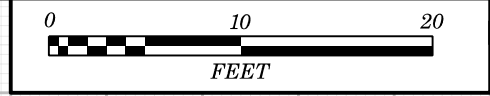

L\_33700\_LT  
337+00 -L-  
79' LT

L\_33700  
337+00 -L-  
1' RT

EXISTING PAVEMENT

ROADWAY EMBANKMENT, LOOSE TO MEDIUM DENSE,  
BROWN, SILTY FINE SAND, MOIST (A-2-4)

UNDIVIDED COASTAL PLAIN, LOOSE TO MEDIUM DENSE, LIGHT BROWN,  
CLAYEY FINE TO COARSE SAND, MOIST TO WET, NON PLASTIC

ORANGE, TAN, LIGHT BROWN, BROWN, COARSE TO FINE SAND, SILTY FINE SAND,  
TO SLIGHTLY PLASTIC (A-3, A-2-4, A-2-6)

SOFT TO STIFF, GRAY, VERY LIGHT GRAY, ORANGE, MOTTLED, FINE  
TO COARSE SANDY CLAY, MOIST, SLIGHTLY PLASTIC (A-6)

COASTAL PLAIN, VERY LOOSE TO LOOSE, DARK GRAY, CLAYEY FINE  
SAND, WET TO SATURATED (A-2-6) (BLACK CREEK FORMATION)

- 8
- 11
- 3
- 3
- 5

127.19

BT  
DRY  
03/20

337+00  
1 OF 2

-L-



5 0 5 10 15 20 25 30 35 40 45 50 55 60 65 70 75 80 85 90 95 100 105 110 115 120 125 130 135 140 145

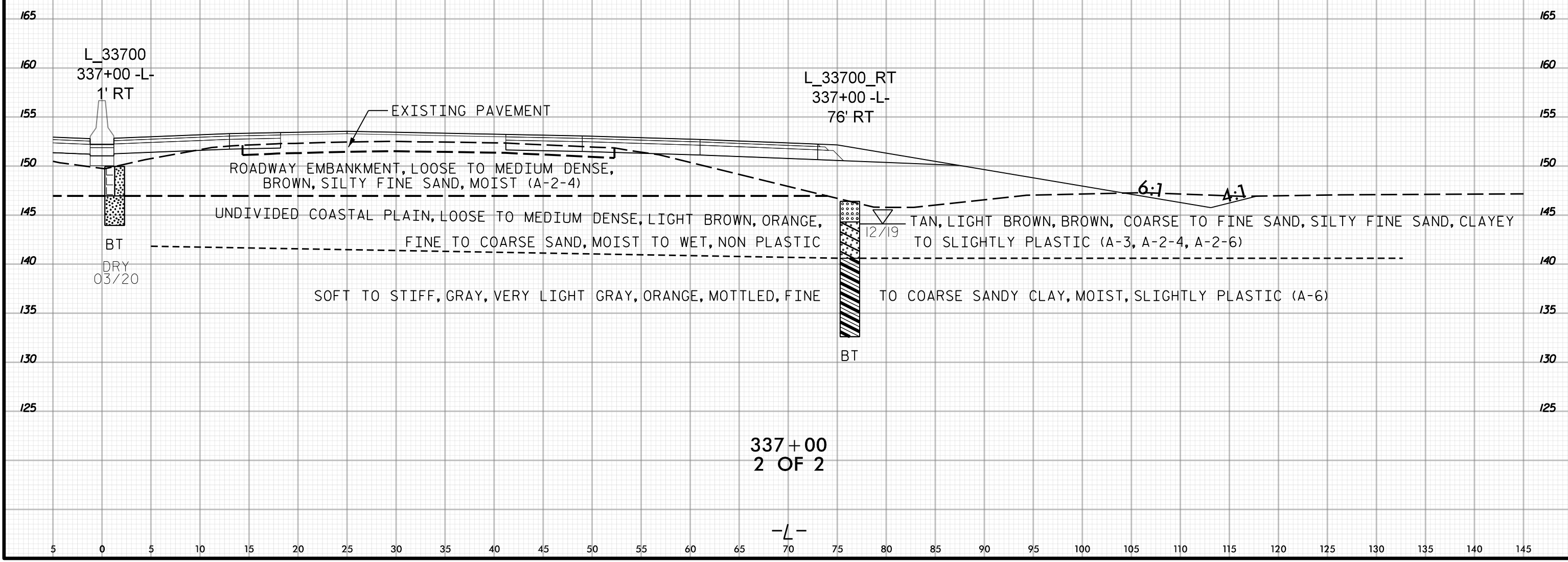



PROJ. REFERENCE NO.	SHEET NO.
I-5987A	572

145 140 135 130 125 120 115 110 105 100 95 90 85 80 75 70 65 60 55 50 45 40 35 30 25 20 15 10 5 0 5

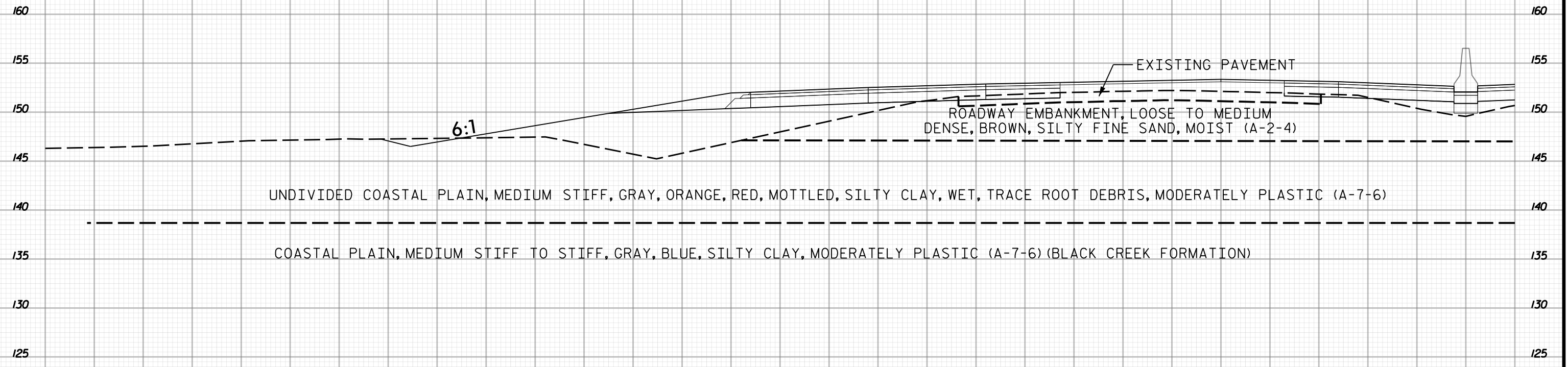

337+50  
1 OF 2

-L-

145 140 135 130 125 120 115 110 105 100 95 90 85 80 75 70 65 60 55 50 45 40 35 30 25 20 15 10 5 0 5



PROJ. REFERENCE NO.	SHEET NO.
I-5987A	573

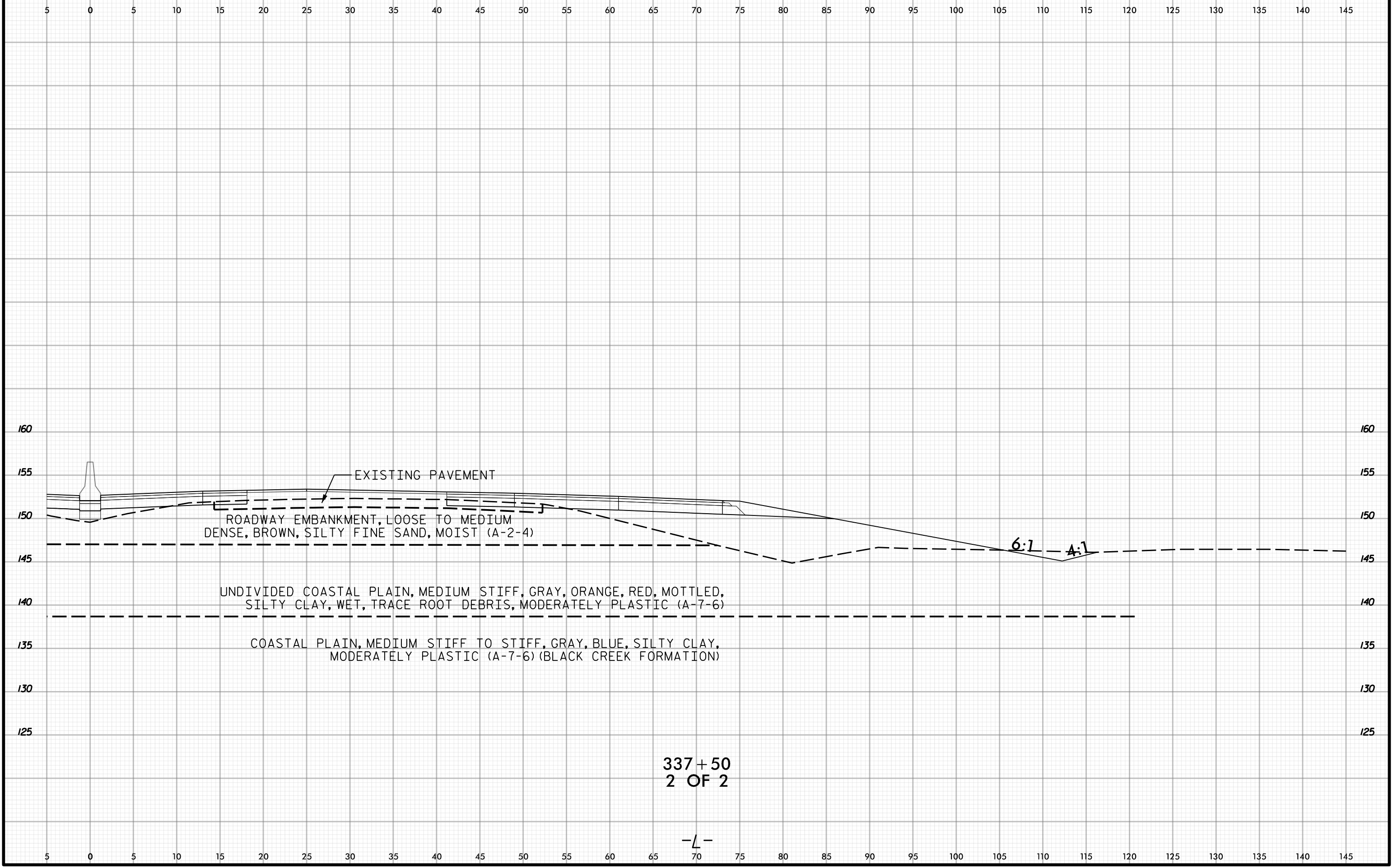

337+50  
2 OF 2

-L-





145 140 135 130 125 120 115 110 105 100 95 90 85 80 75 70 65 60 55 50 45 40 35 30 25 20 15 10 5 0 5

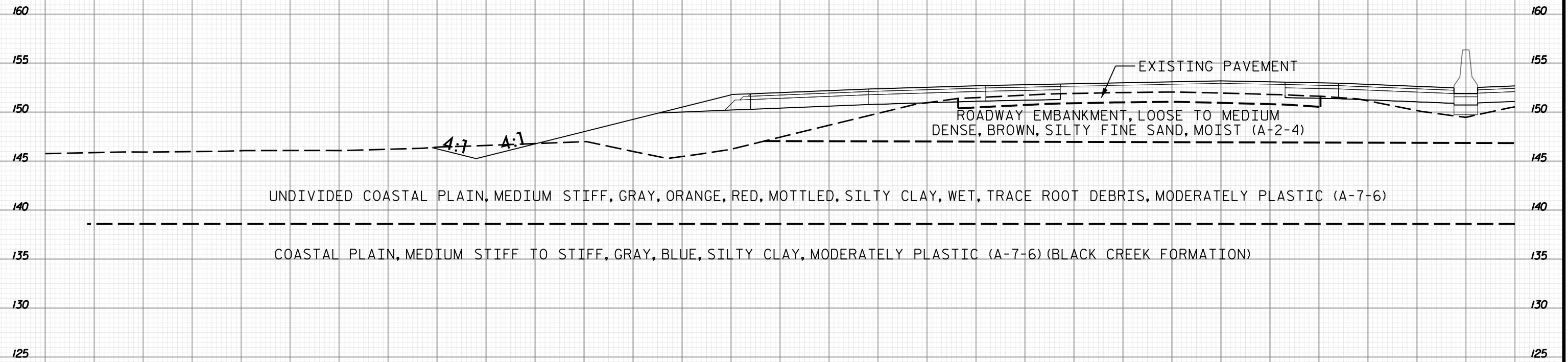

338+00  
1 OF 2

-L-

145 140 135 130 125 120 115 110 105 100 95 90 85 80 75 70 65 60 55 50 45 40 35 30 25 20 15 10 5 0 5



PROJ. REFERENCE NO.	SHEET NO.
I-5987A	575

5 0 5 10 15 20 25 30 35 40 45 50 55 60 65 70 75 80 85 90 95 100 105 110 115 120 125 130 135 140 145

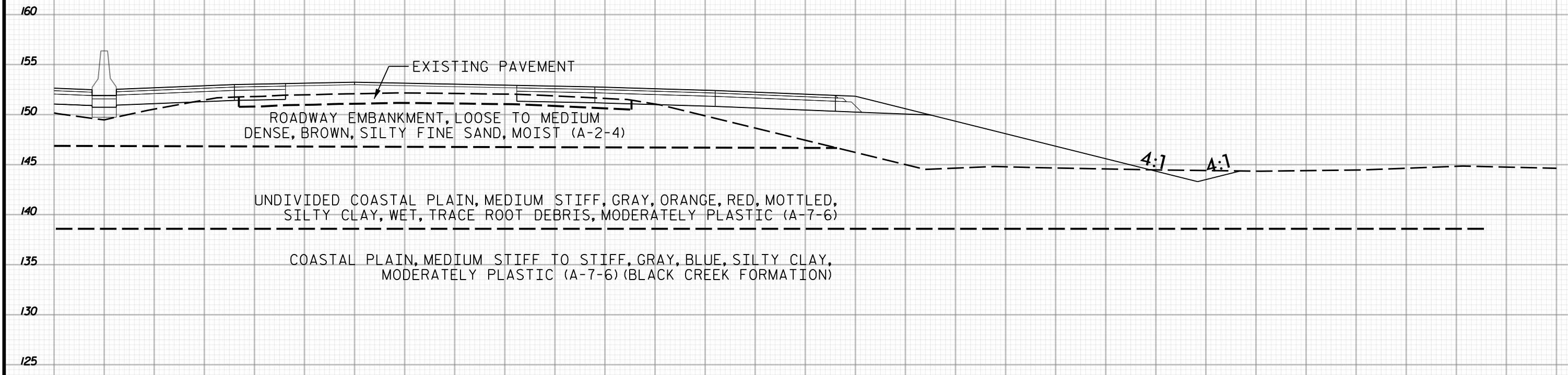

338+00  
2 OF 2

-L-

5 0 5 10 15 20 25 30 35 40 45 50 55 60 65 70 75 80 85 90 95 100 105 110 115 120 125 130 135 140 145



PROJ. REFERENCE NO.	SHEET NO.
I-5987A	576

145 140 135 130 125 120 115 110 105 100 95 90 85 80 75 70 65 60 55 50 45 40 35 30 25 20 15 10 5 0 5

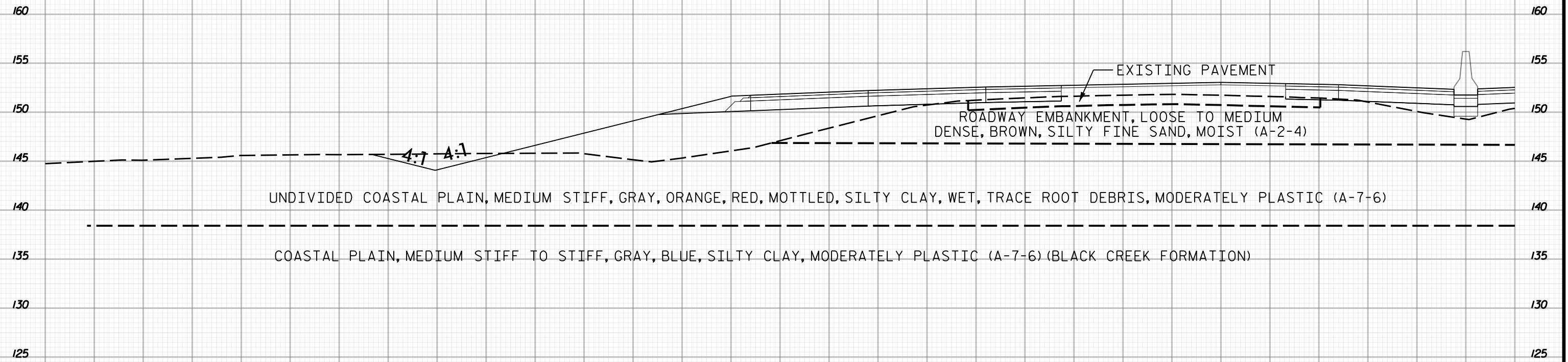

338 + 50  
1 OF 2

-L-

145 140 135 130 125 120 115 110 105 100 95 90 85 80 75 70 65 60 55 50 45 40 35 30 25 20 15 10 5 0 5



PROJ. REFERENCE NO.	SHEET NO.
I-5987A	577

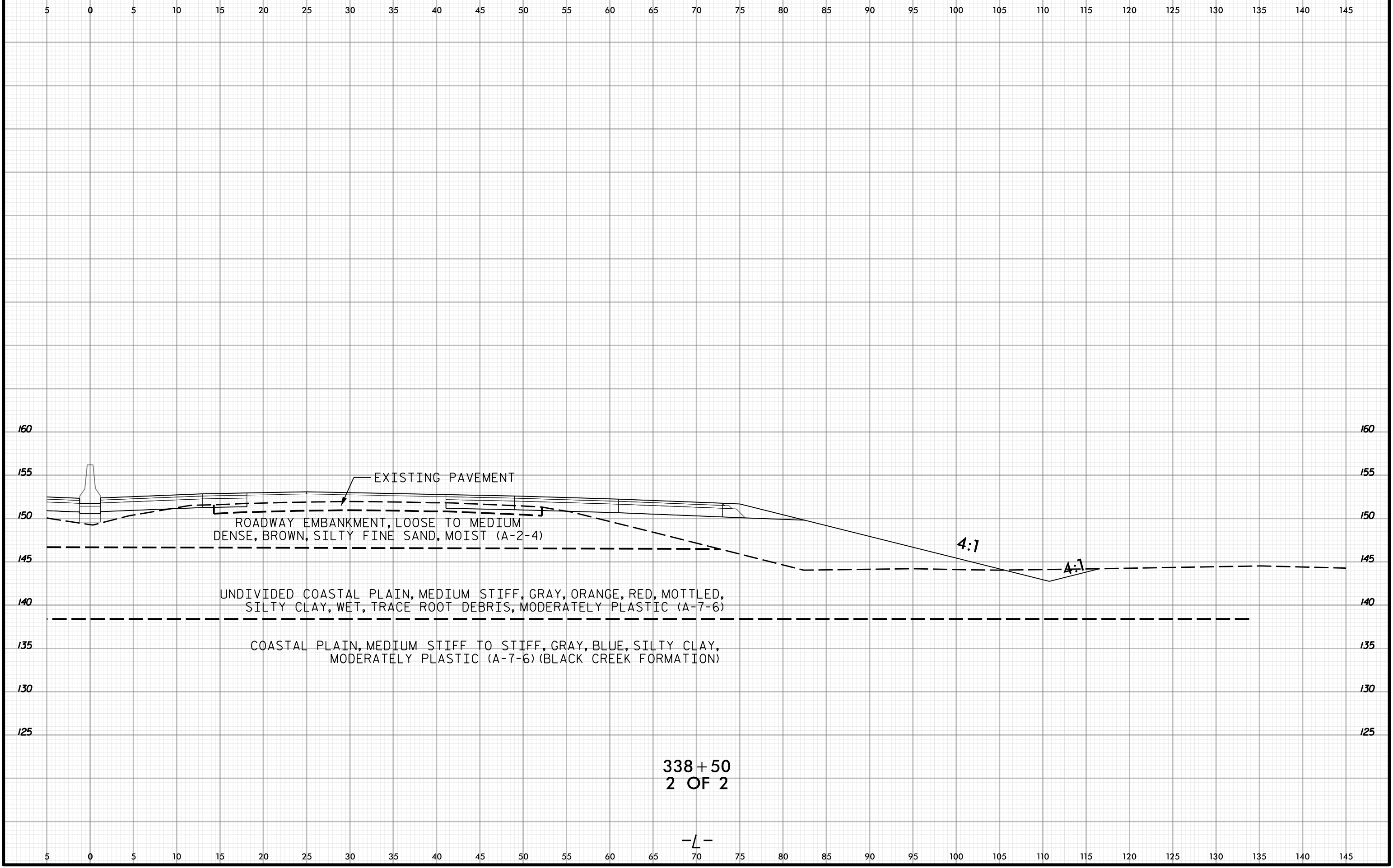

EXISTING PAVEMENT

ROADWAY EMBANKMENT, LOOSE TO MEDIUM  
DENSE, BROWN, SILTY FINE SAND, MOIST (A-2-4)

UNDIVIDED COASTAL PLAIN, MEDIUM STIFF, GRAY, ORANGE, RED, MOTTLED,  
SILTY CLAY, WET, TRACE ROOT DEBRIS, MODERATELY PLASTIC (A-7-6)

COASTAL PLAIN, MEDIUM STIFF TO STIFF, GRAY, BLUE, SILTY CLAY,  
MODERATELY PLASTIC (A-7-6) (BLACK CREEK FORMATION)

4:1

4:1

338+50  
2 OF 2

-L-

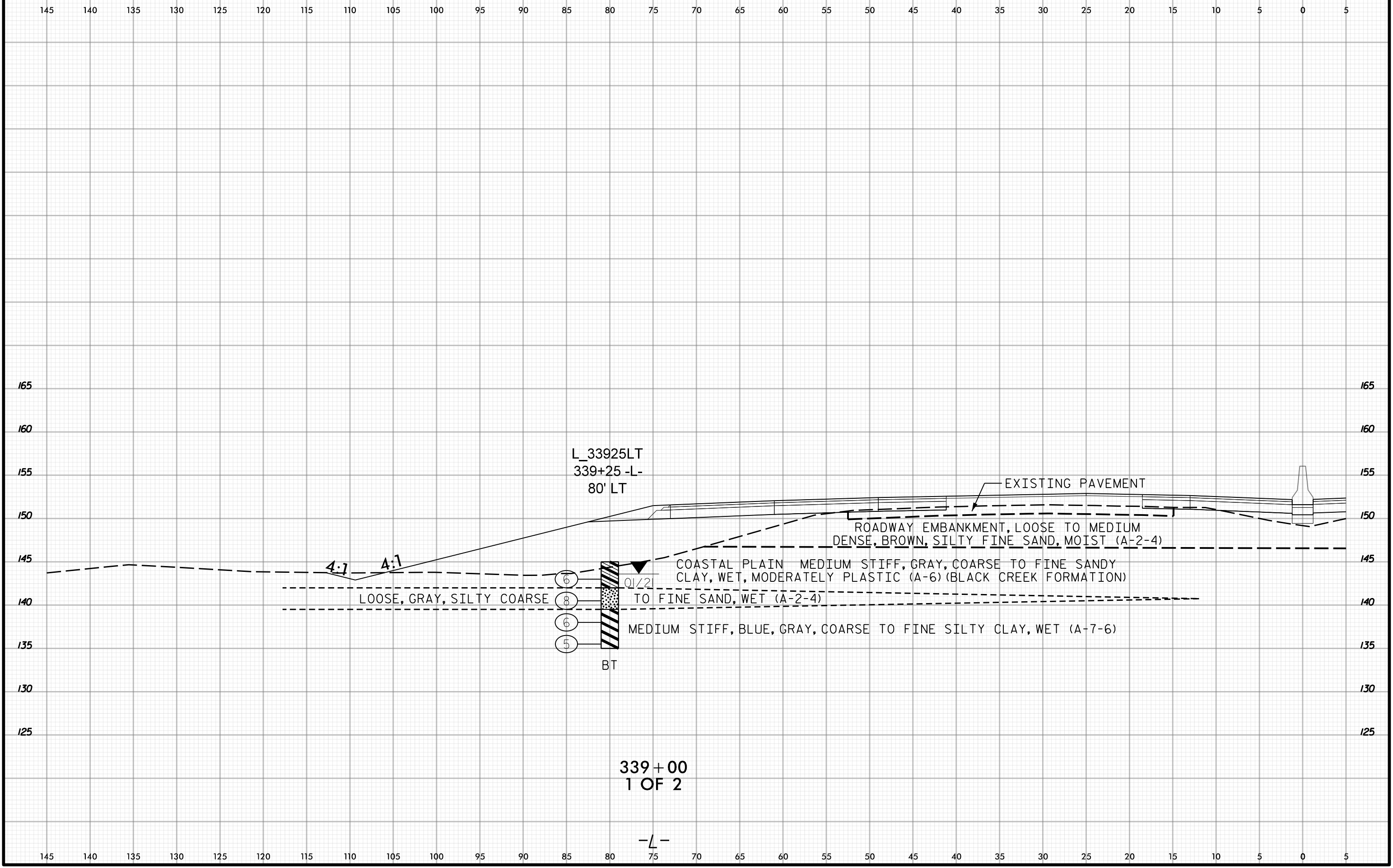
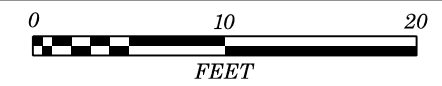

L\_33925LT  
339+25 -L-  
80' LT

EXISTING PAVEMENT

ROADWAY EMBANKMENT, LOOSE TO MEDIUM  
DENSE, BROWN, SILTY FINE SAND, MOIST (A-2-4)

COASTAL PLAIN MEDIUM STIFF, GRAY, COARSE TO FINE SANDY  
CLAY, WET, MODERATELY PLASTIC (A-6) (BLACK CREEK FORMATION)

LOOSE, GRAY, SILTY COARSE

TO FINE SAND, WET (A-2-4)

MEDIUM STIFF, BLUE, GRAY, COARSE TO FINE SILTY CLAY, WET (A-7-6)

BT

339+00  
1 OF 2

-L-



5 0 5 10 15 20 25 30 35 40 45 50 55 60 65 70 75 80 85 90 95 100 105 110 115 120 125 130 135 140 145

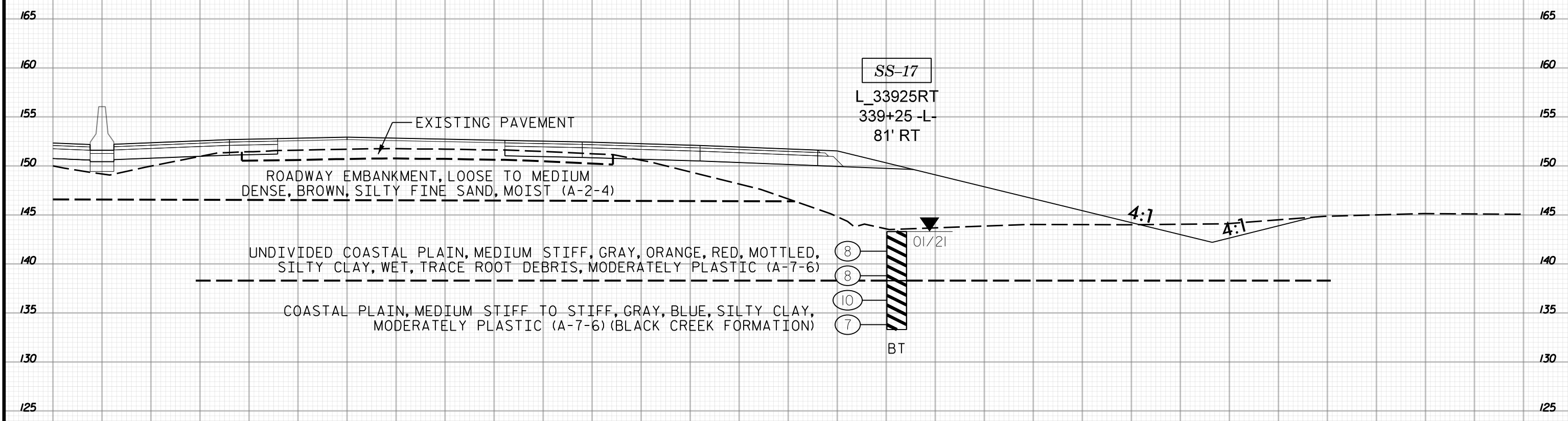

339+00  
2 OF 2

5 0 5 10 15 20 25 30 35 40 45 50 55 60 65 70 75 80 85 90 95 100 105 110 115 120 125 130 135 140 145

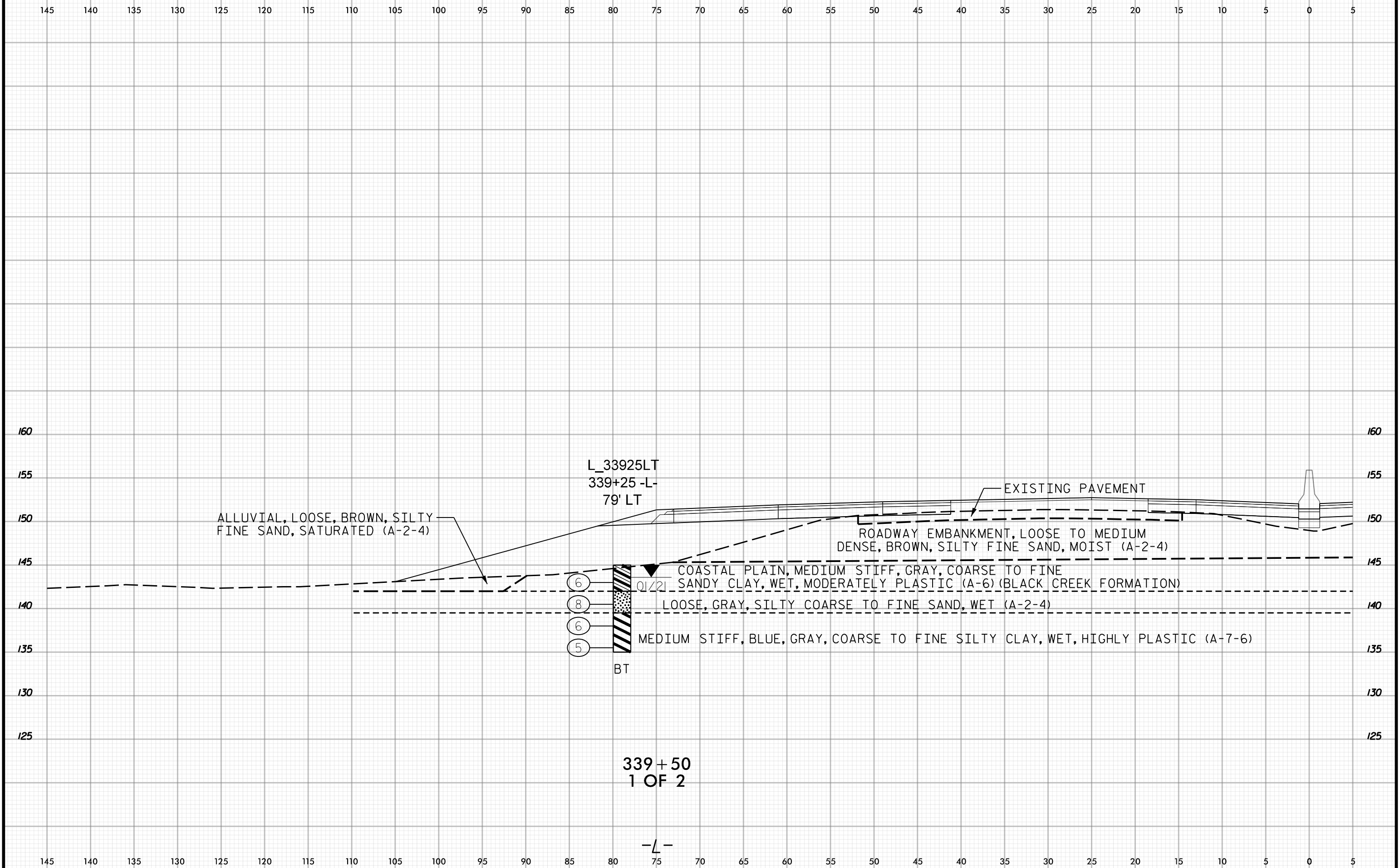

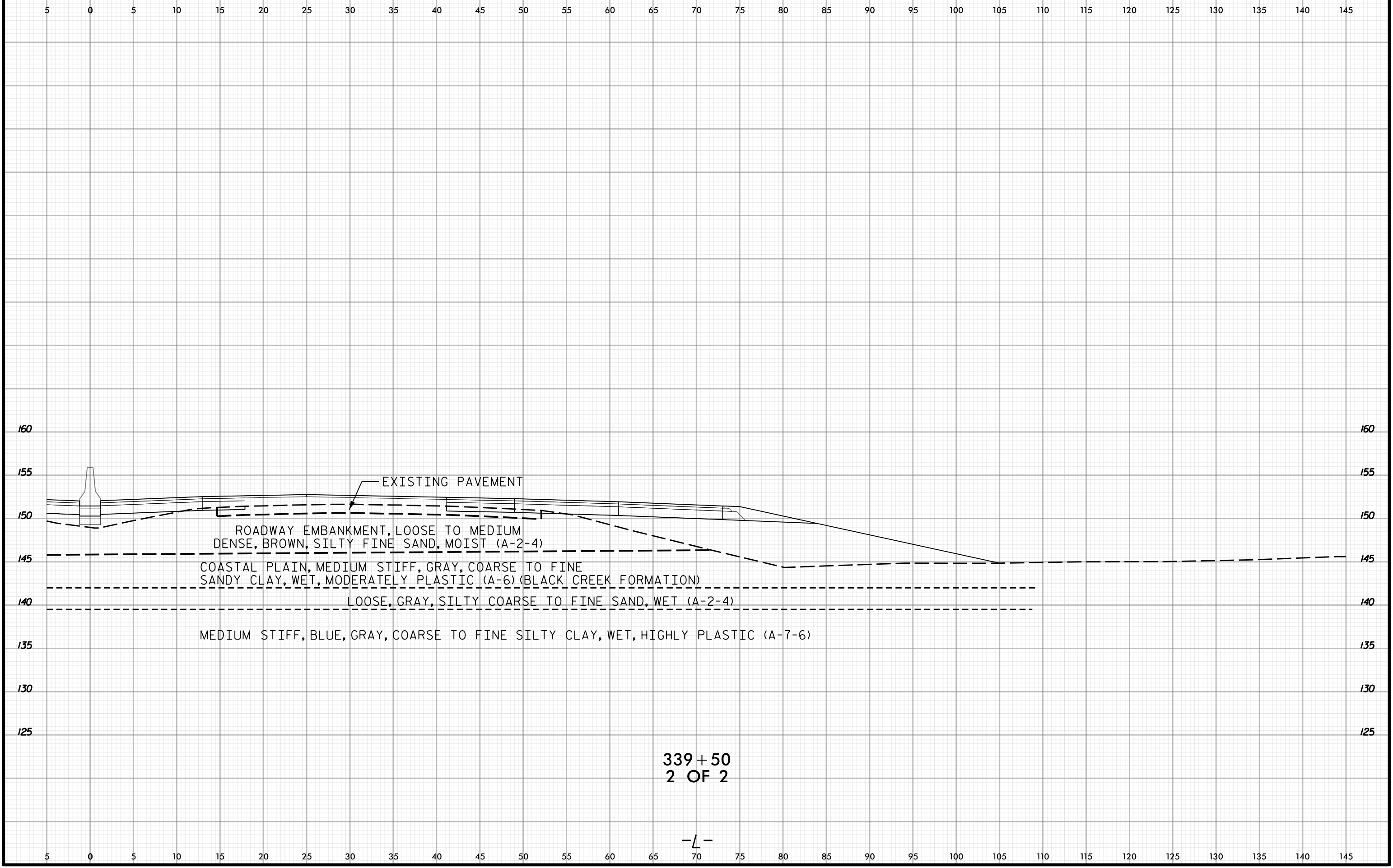





145 140 135 130 125 120 115 110 105 100 95 90 85 80 75 70 65 60 55 50 45 40 35 30 25 20 15 10 5 0 5

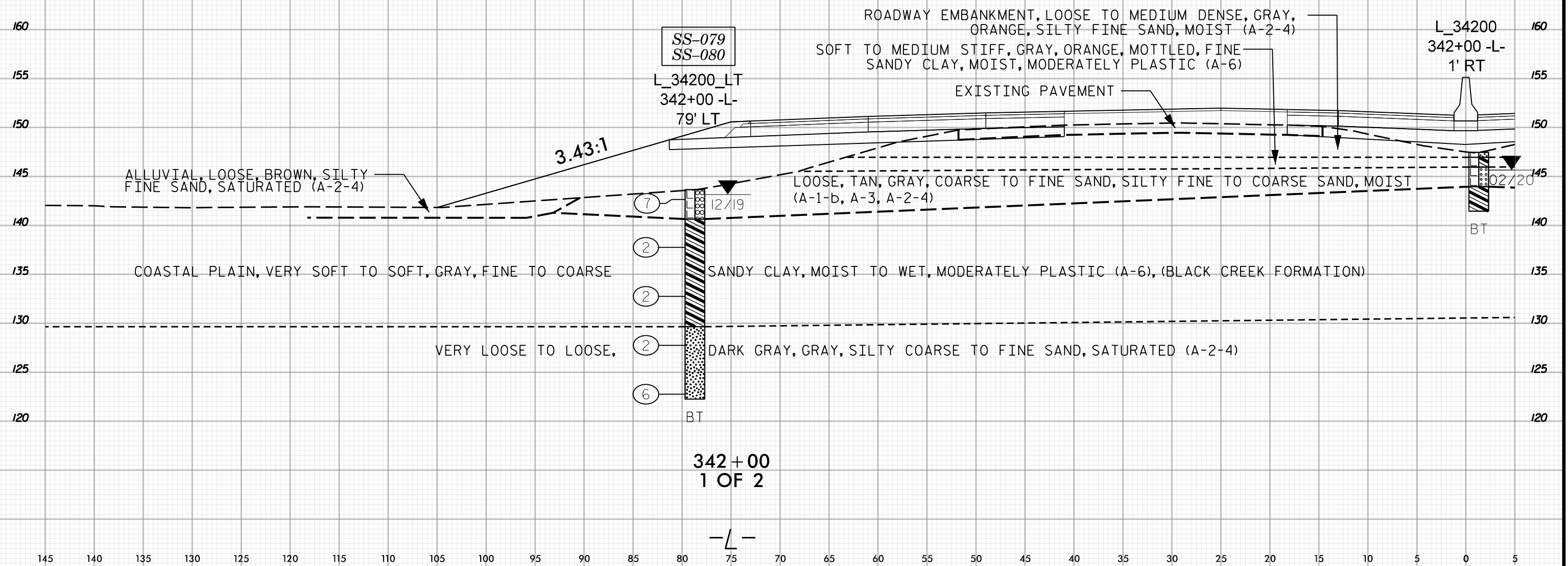



5 0 5 10 15 20 25 30 35 40 45 50 55 60 65 70 75 80 85 90 95 100 105 110 115 120 125 130 135 140 145

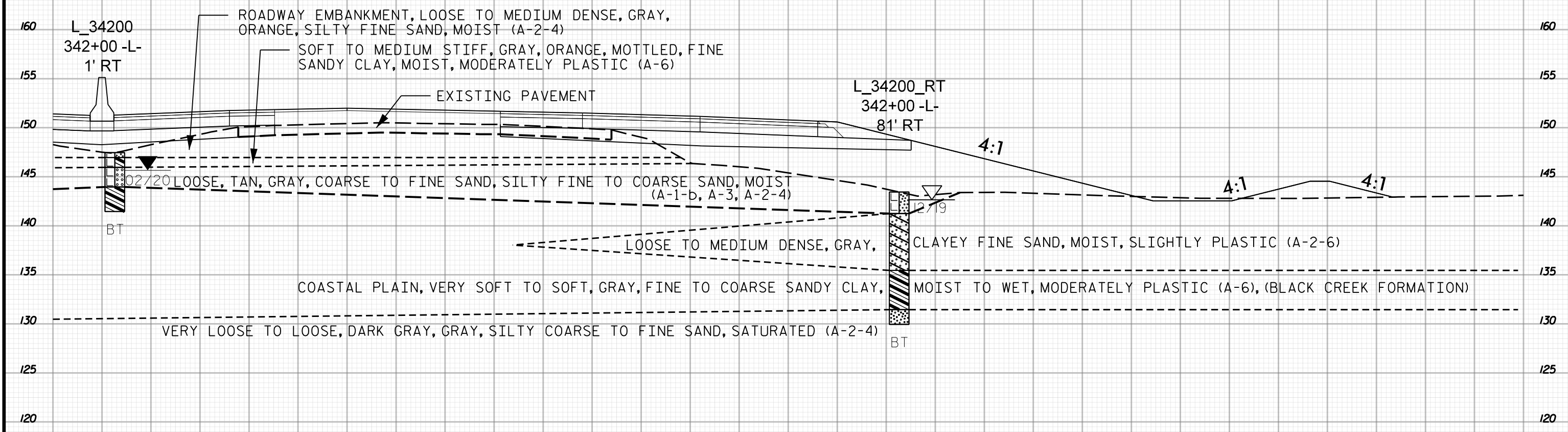

342+00  
2 OF 2

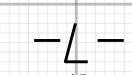

5 0 5 10 15 20 25 30 35 40 45 50 55 60 65 70 75 80 85 90 95 100 105 110 115 120 125 130 135 140 145

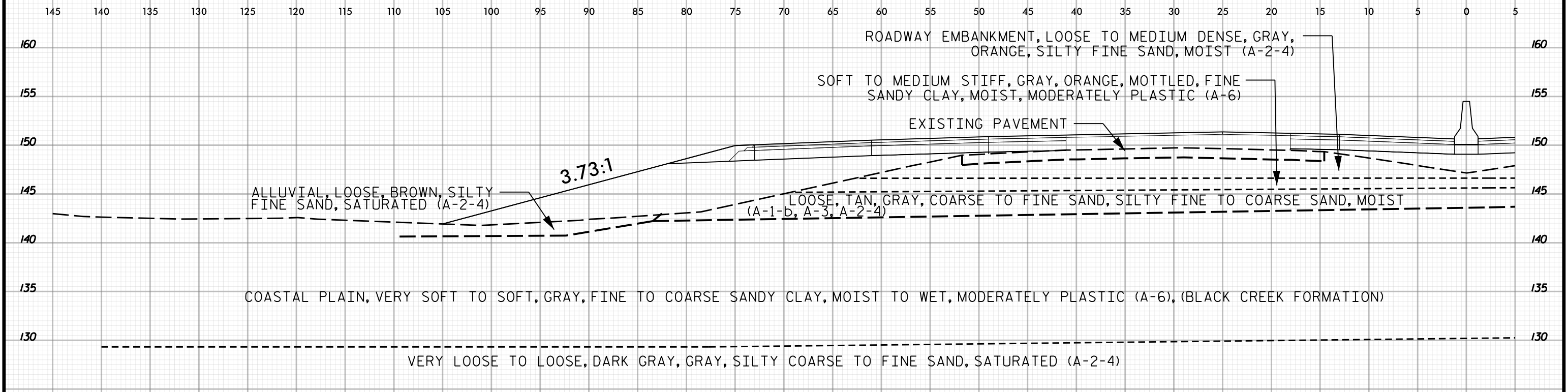

344+00

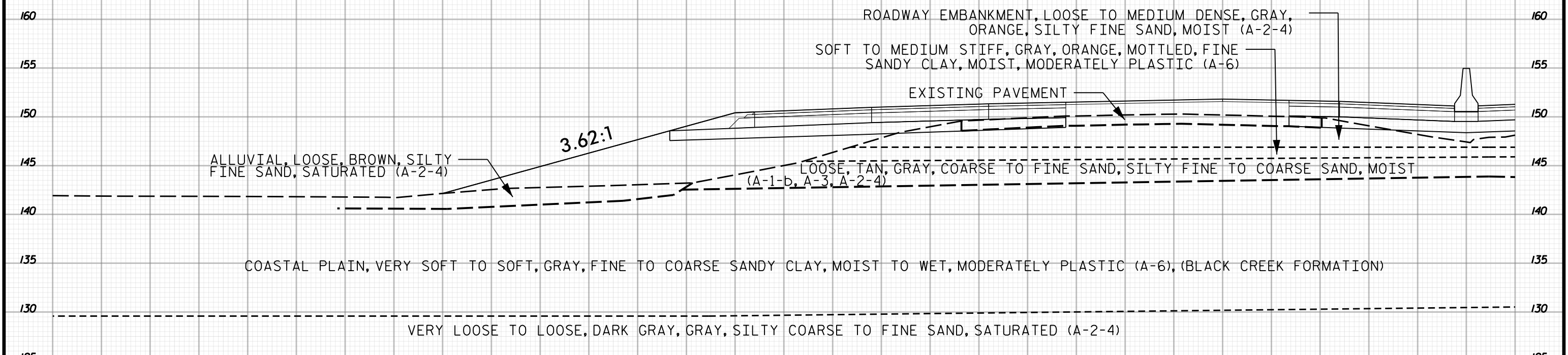

342+50  
1 OF 2

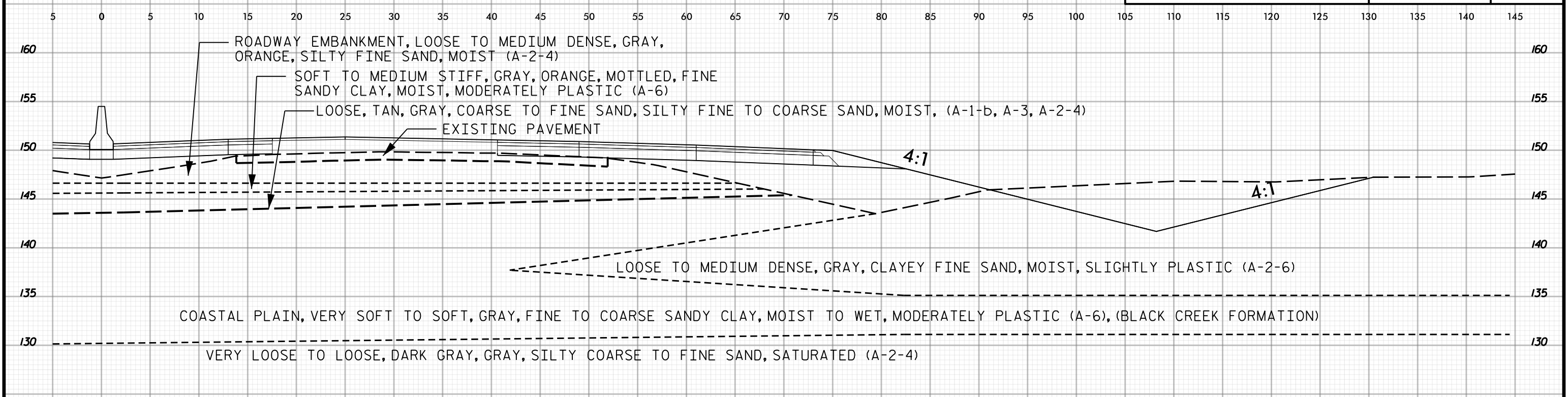
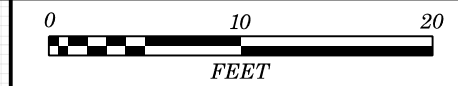

344+00

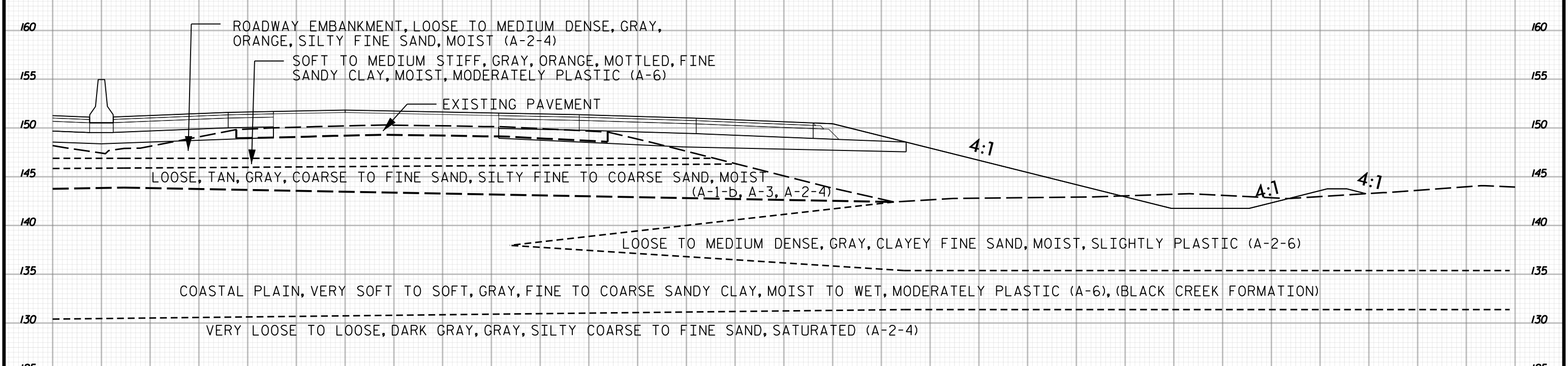

342+50  
2 OF 2

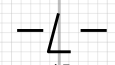

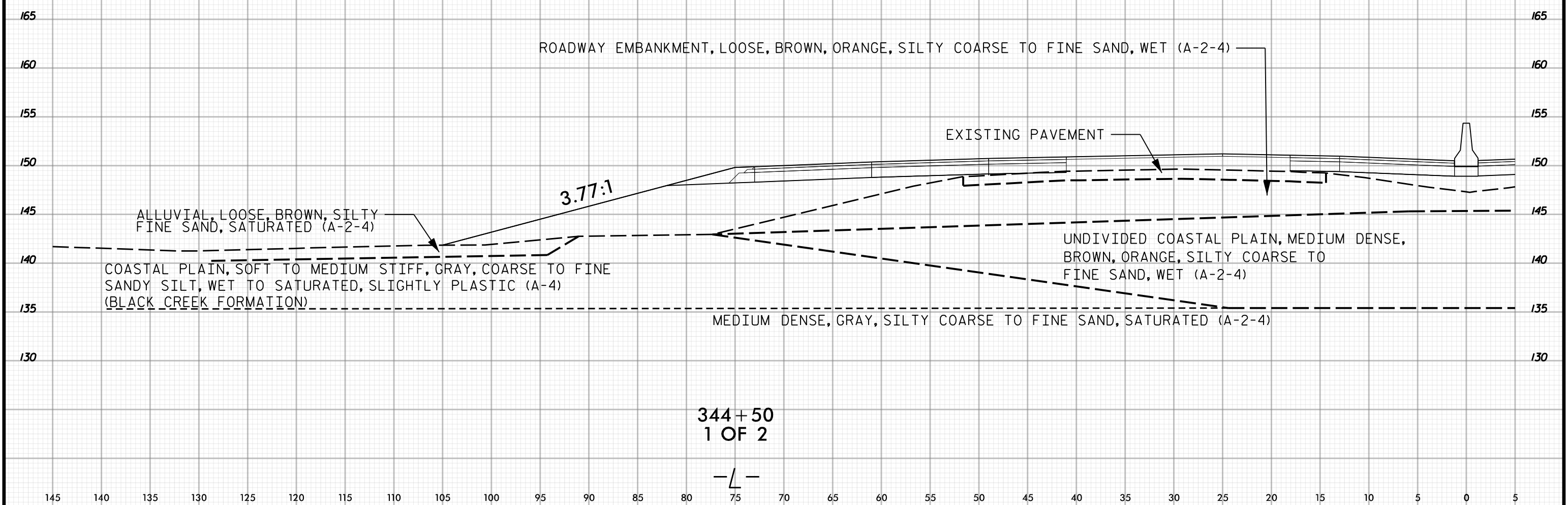
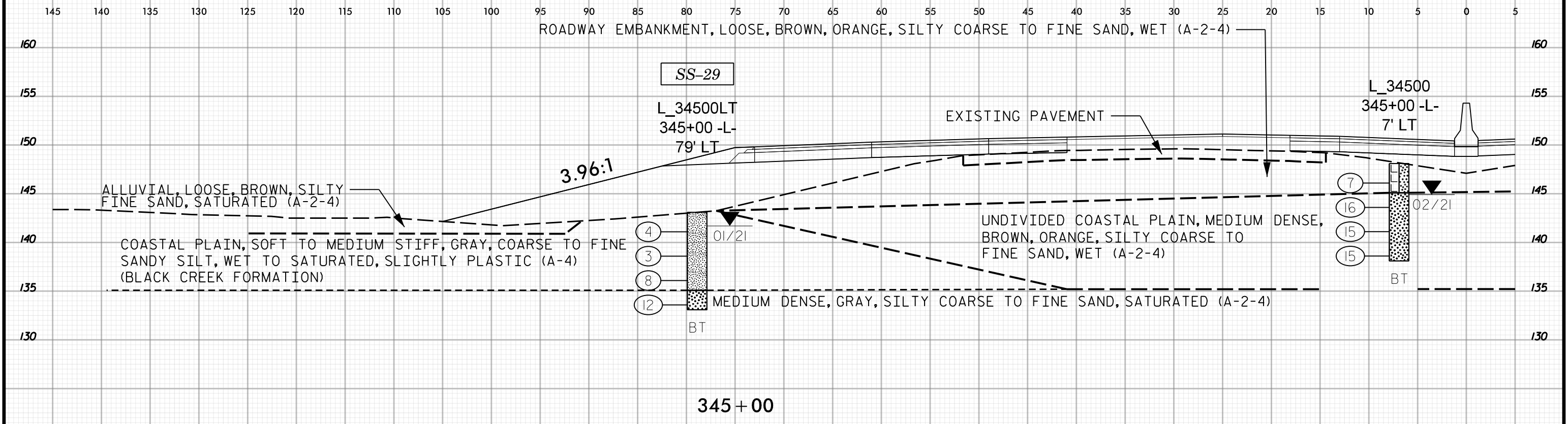
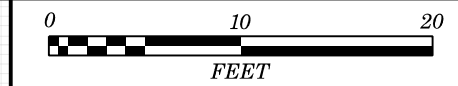

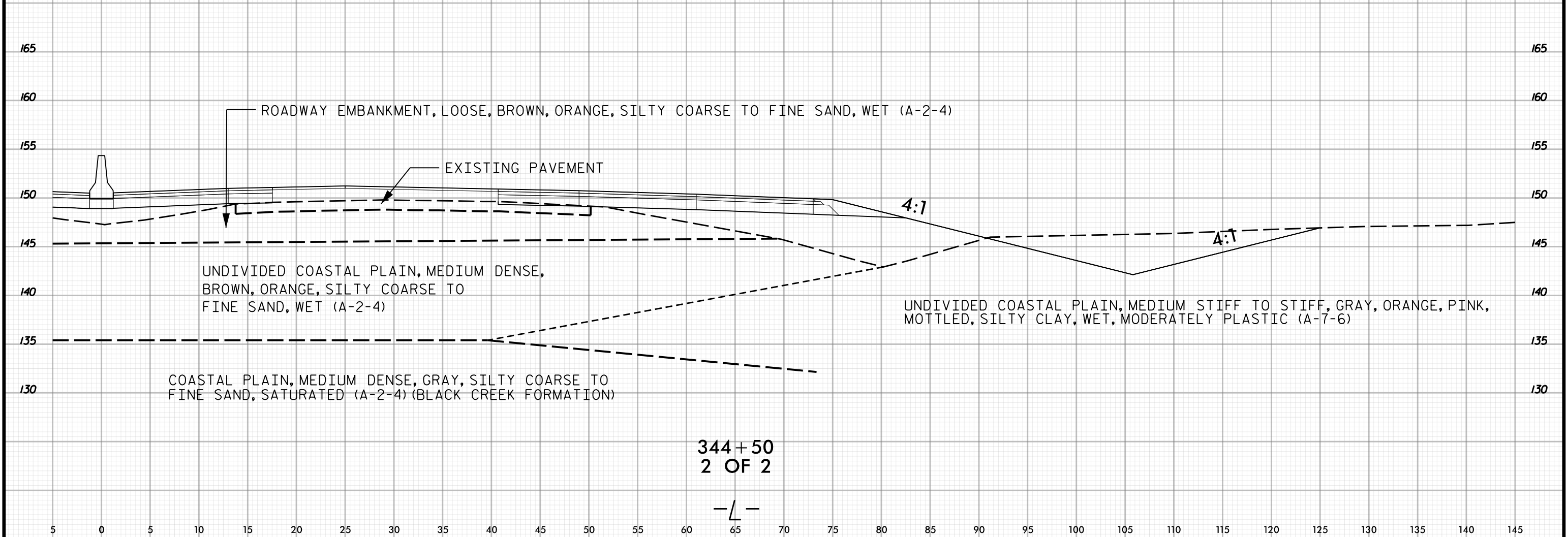
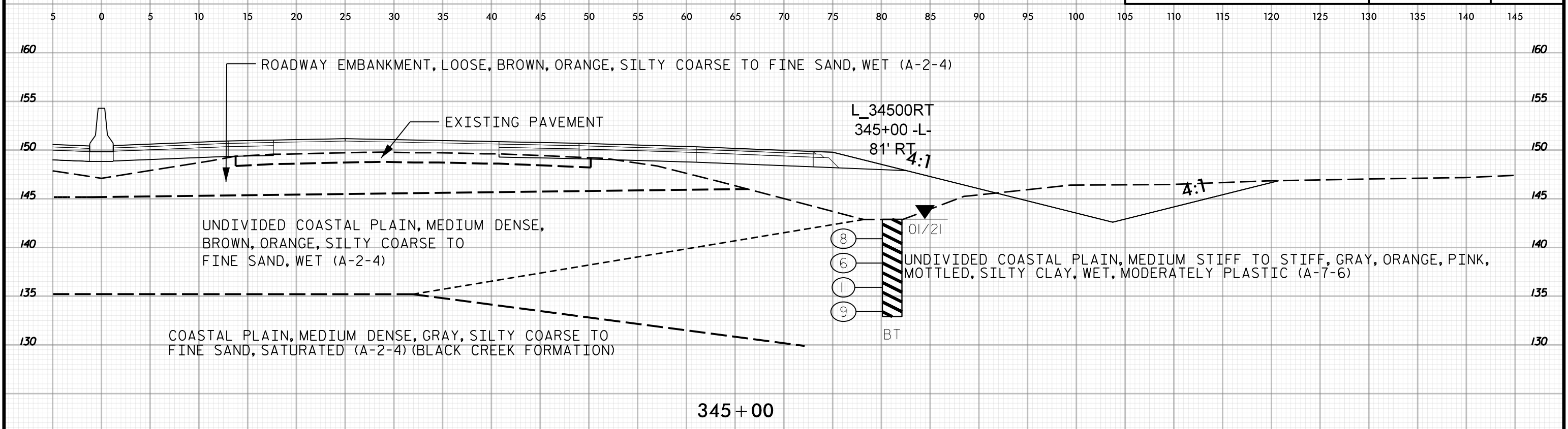



145 140 135 130 125 120 115 110 105 100 95 90 85 80 75 70 65 60 55 50 45 40 35 30 25 20 15 10 5 0 5

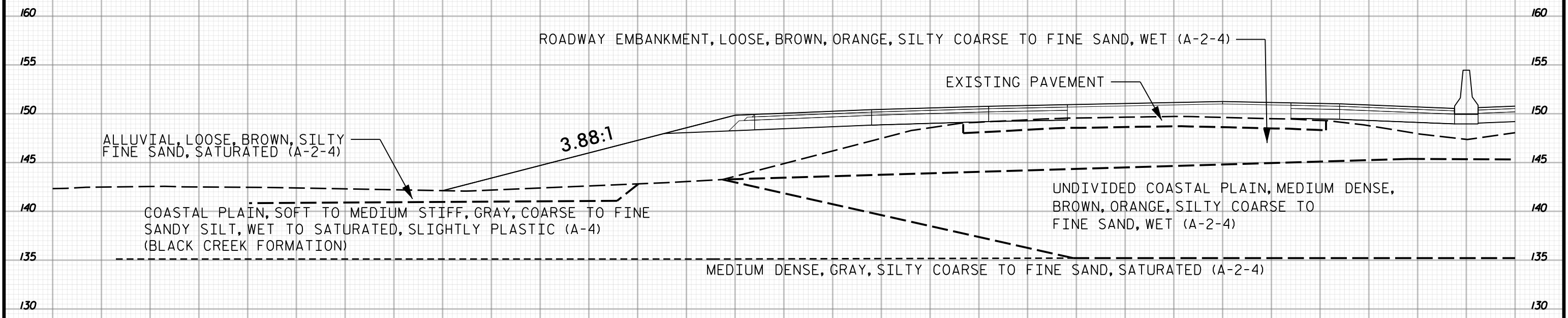

346+00

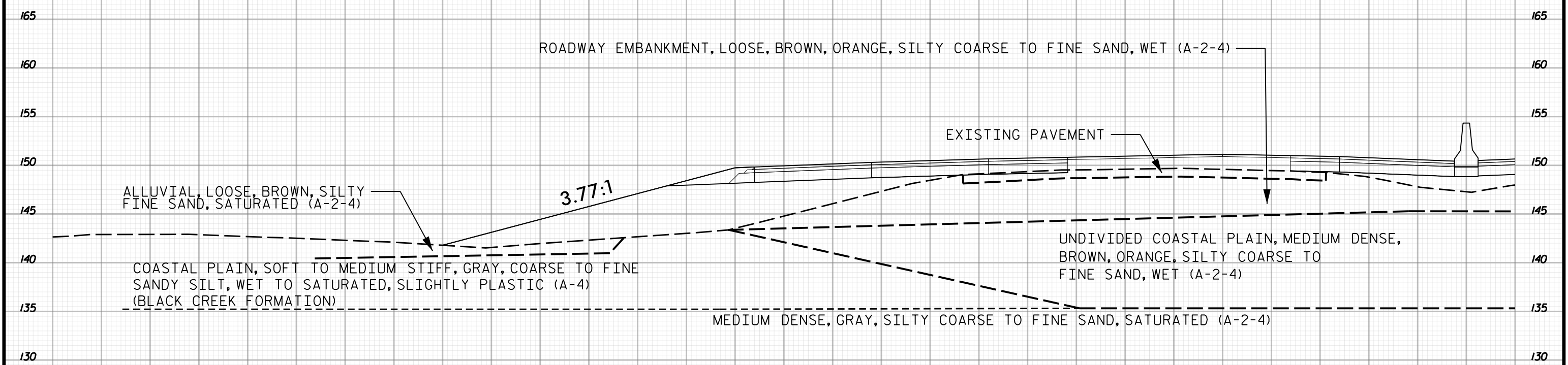

345+50  
1 OF 2

145 140 135 130 125 120 115 110 105 100 95 90 85 80 75 70 65 60 55 50 45 40 35 30 25 20 15 10 5 0 5

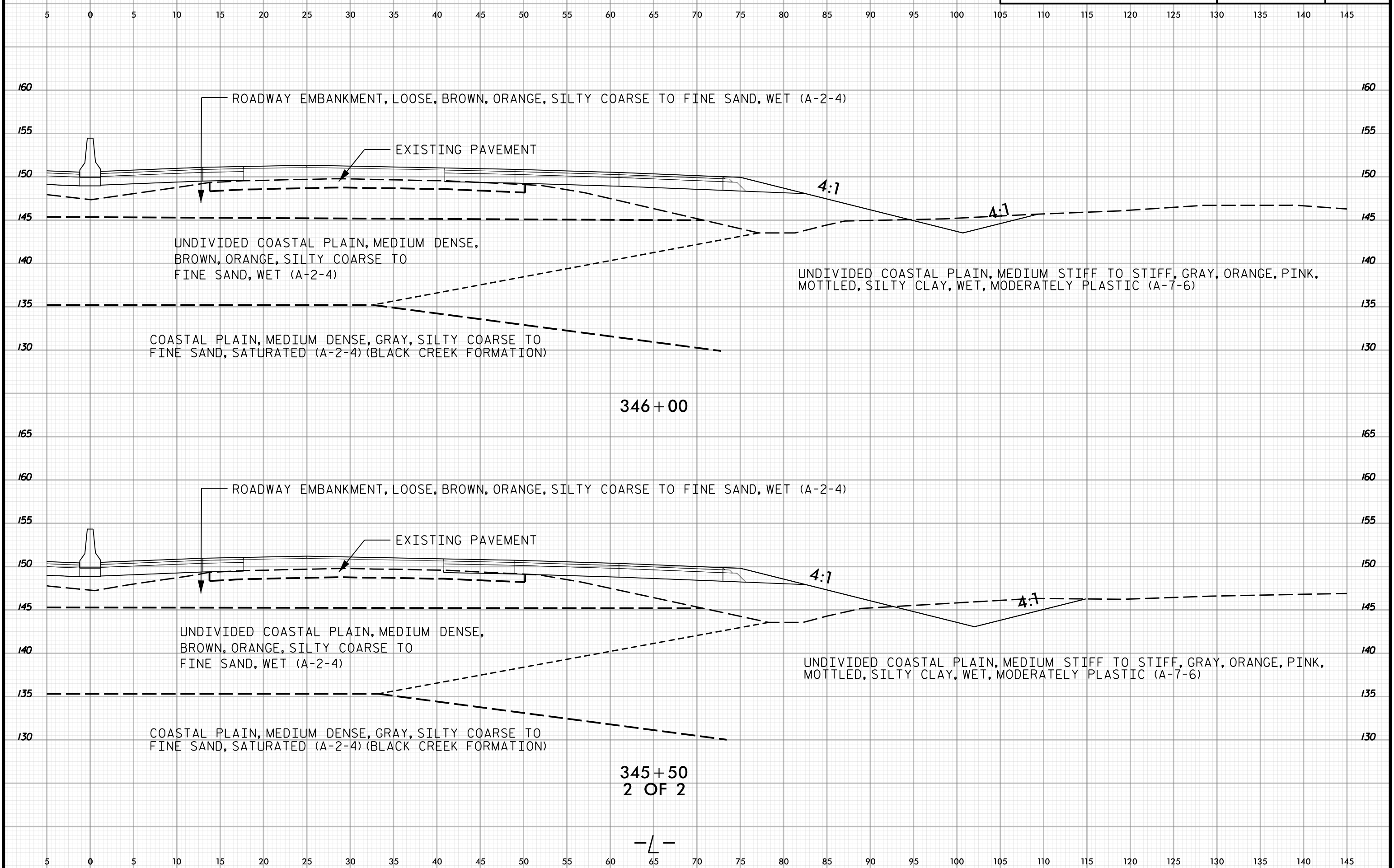
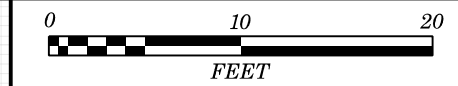

ROADWAY EMBANKMENT, LOOSE, BROWN, ORANGE, SILTY COARSE TO FINE SAND, WET (A-2-4)

EXISTING PAVEMENT

UNDIVIDED COASTAL PLAIN, MEDIUM DENSE, BROWN, ORANGE, SILTY COARSE TO FINE SAND, WET (A-2-4)

UNDIVIDED COASTAL PLAIN, MEDIUM STIFF TO STIFF, GRAY, ORANGE, PINK, MOTTLED, SILTY CLAY, WET, MODERATELY PLASTIC (A-7-6)

COASTAL PLAIN, MEDIUM DENSE, GRAY, SILTY COARSE TO FINE SAND, SATURATED (A-2-4) (BLACK CREEK FORMATION)

346+00

ROADWAY EMBANKMENT, LOOSE, BROWN, ORANGE, SILTY COARSE TO FINE SAND, WET (A-2-4)

EXISTING PAVEMENT

UNDIVIDED COASTAL PLAIN, MEDIUM DENSE, BROWN, ORANGE, SILTY COARSE TO FINE SAND, WET (A-2-4)

UNDIVIDED COASTAL PLAIN, MEDIUM STIFF TO STIFF, GRAY, ORANGE, PINK, MOTTLED, SILTY CLAY, WET, MODERATELY PLASTIC (A-7-6)

COASTAL PLAIN, MEDIUM DENSE, GRAY, SILTY COARSE TO FINE SAND, SATURATED (A-2-4) (BLACK CREEK FORMATION)

345+50  
2 OF 2

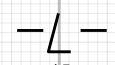





145 140 135 130 125 120 115 110 105 100 95 90 85 80 75 70 65 60 55 50 45 40 35 30 25 20 15 10 5 0 5

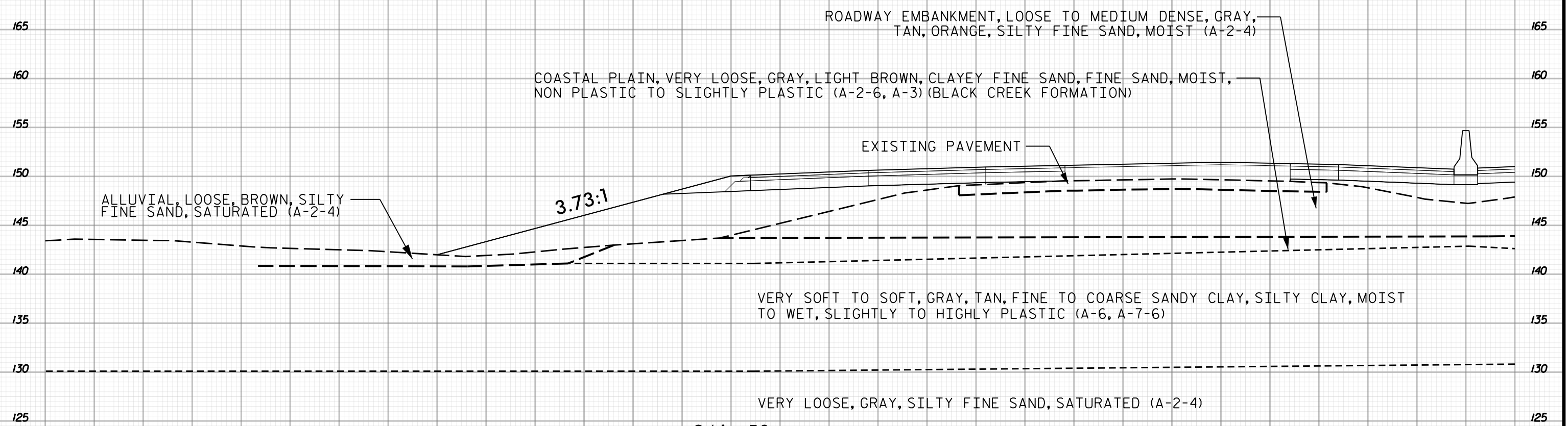

145 140 135 130 125 120 115 110 105 100 95 90 85 80 75 70 65 60 55 50 45 40 35 30 25 20 15 10 5 0 5

346 + 50  
1 OF 2

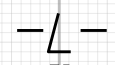



5 0 5 10 15 20 25 30 35 40 45 50 55 60 65 70 75 80 85 90 95 100 105 110 115 120 125 130 135 140 145

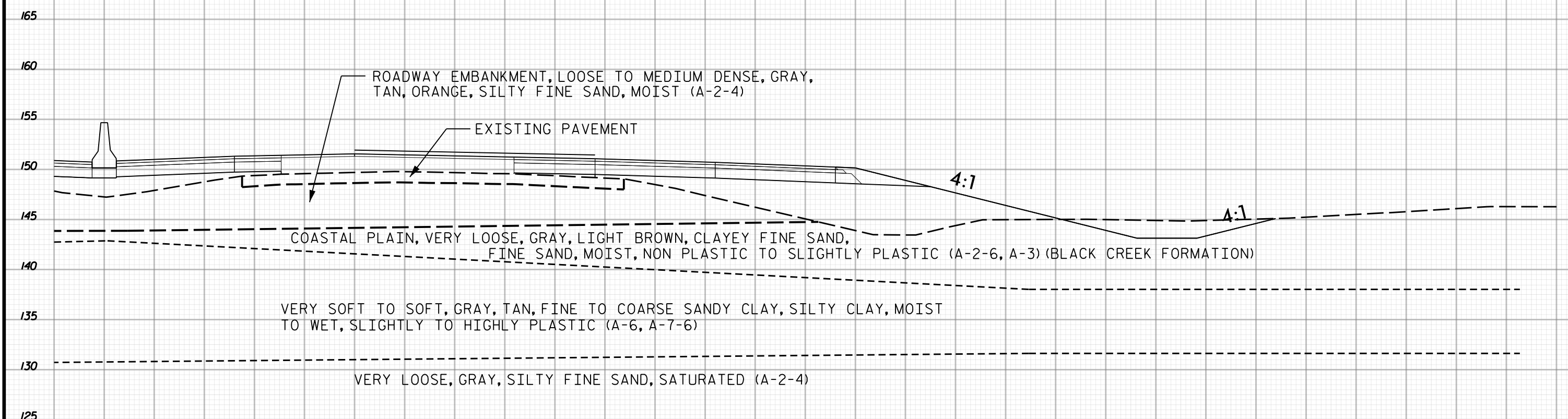

346+50  
2 OF 2

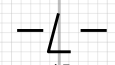

5 0 5 10 15 20 25 30 35 40 45 50 55 60 65 70 75 80 85 90 95 100 105 110 115 120 125 130 135 140 145

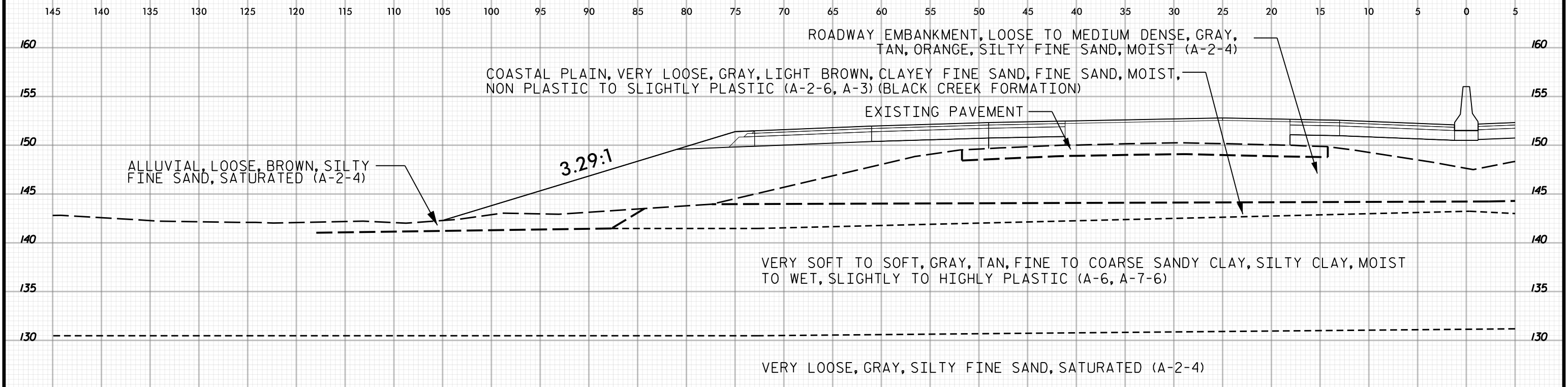
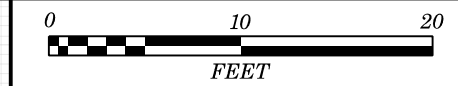

349 + 00

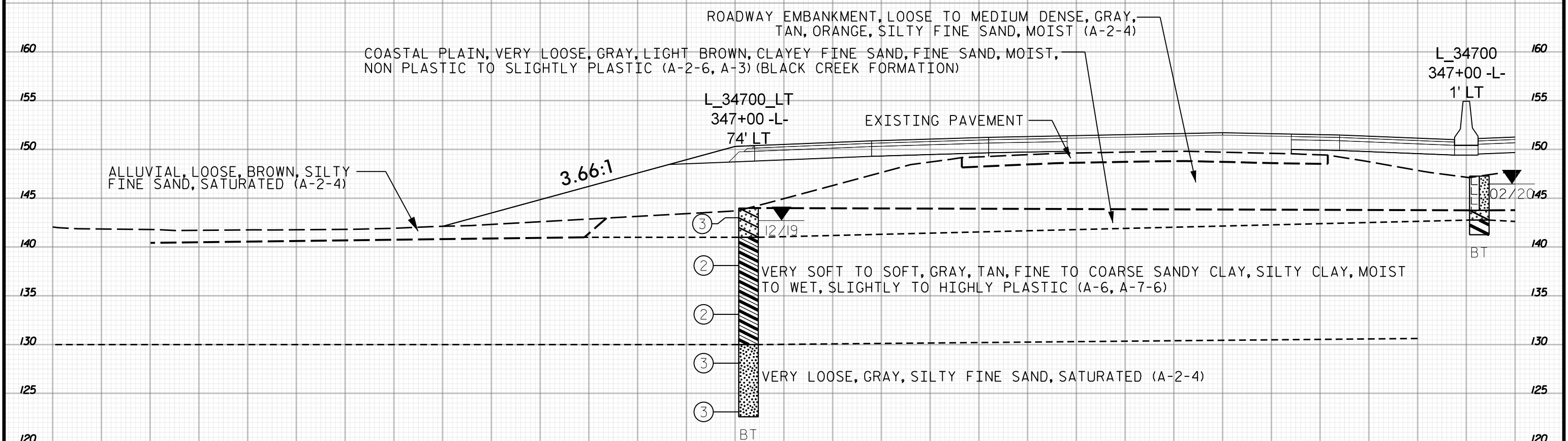

347 + 00  
1 OF 2

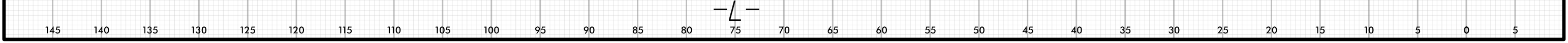

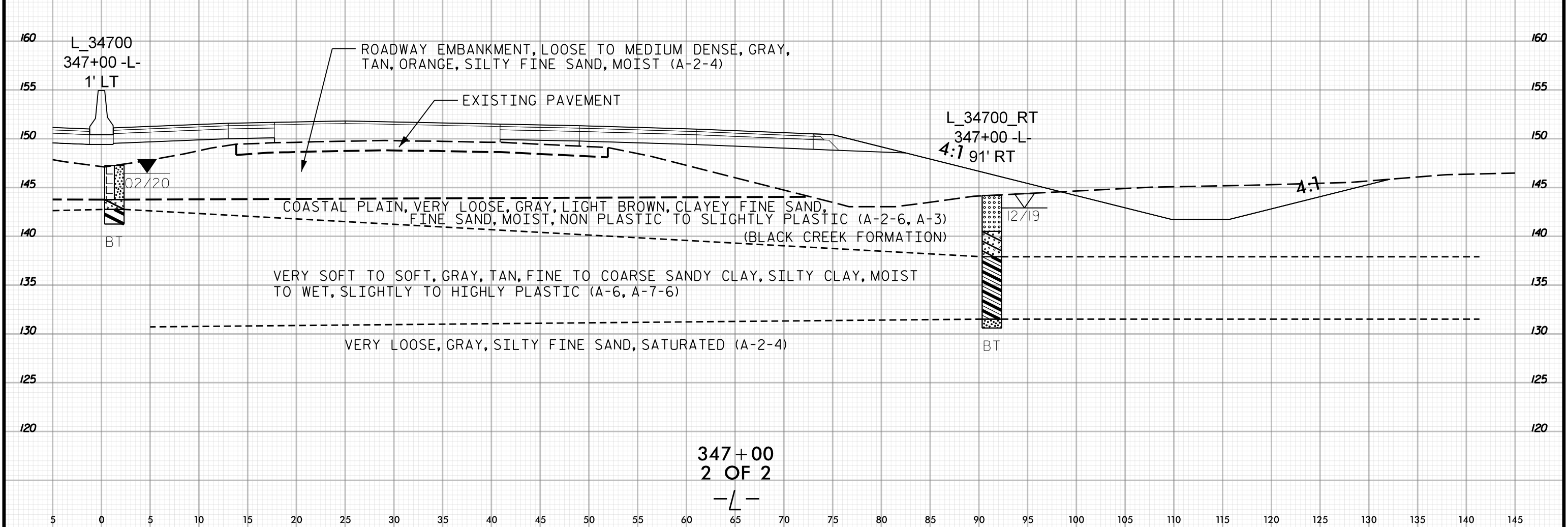
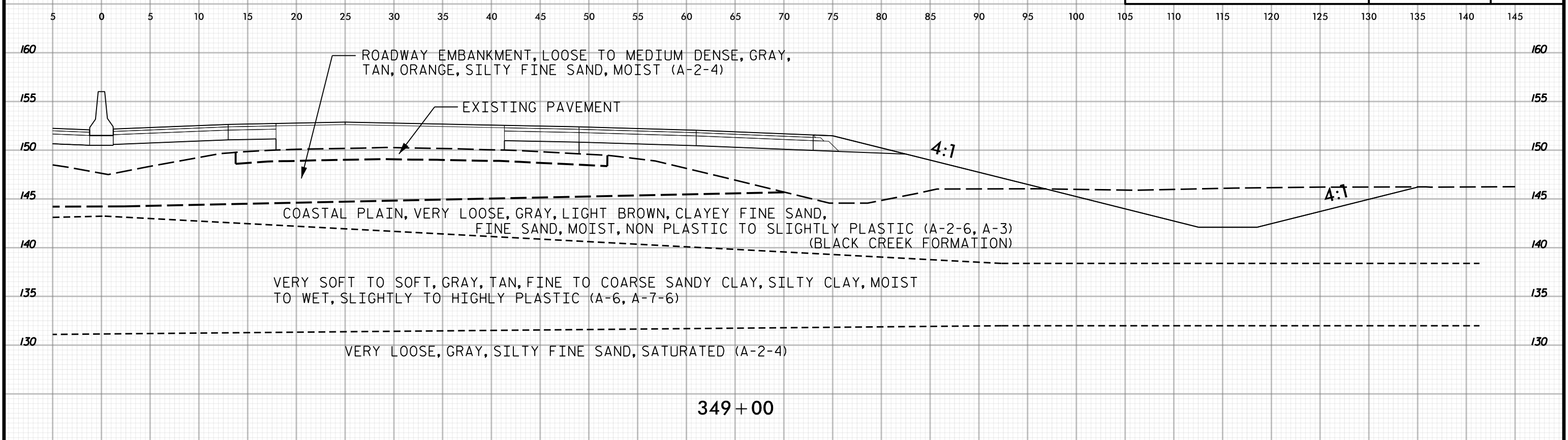
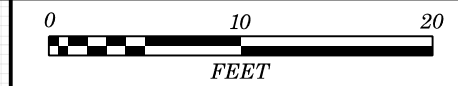



PROJ. REFERENCE NO.	SHEET NO.
I-5987A	594

140 135 130 125 120 115 110 105 100 95 90 85 80 75 70 65 60 55 50 45 40 35 30 25 20 15 10 5 0 5

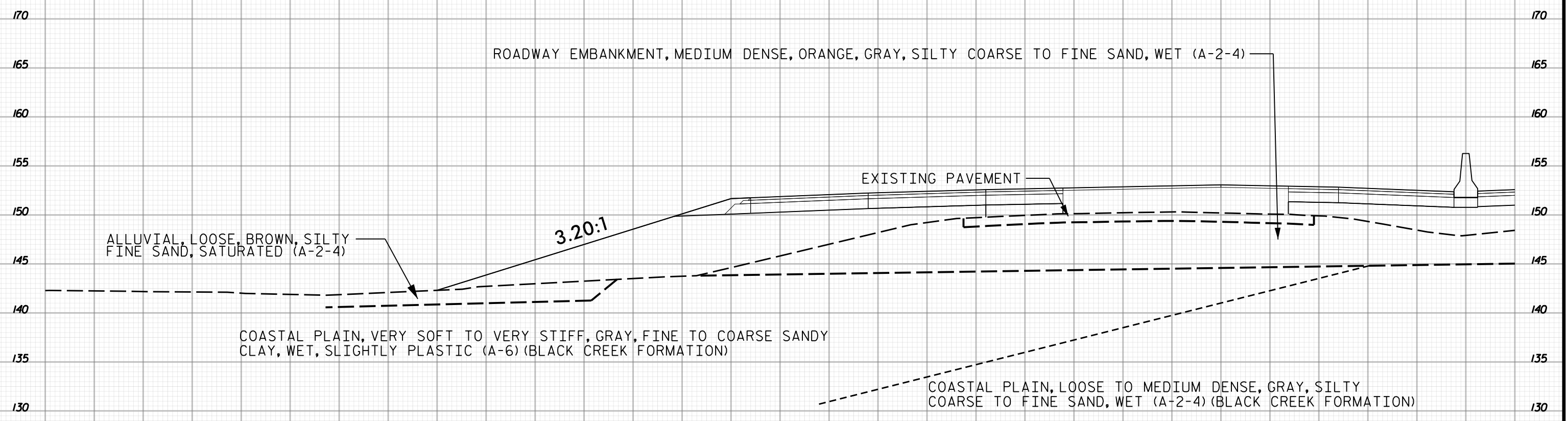

349+50  
1 OF 2

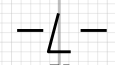

140 135 130 125 120 115 110 105 100 95 90 85 80 75 70 65 60 55 50 45 40 35 30 25 20 15 10 5 0 5



5 0 5 10 15 20 25 30 35 40 45 50 55 60 65 70 75 80 85 90 95 100 105 110 115 120 125 130 135 140 145

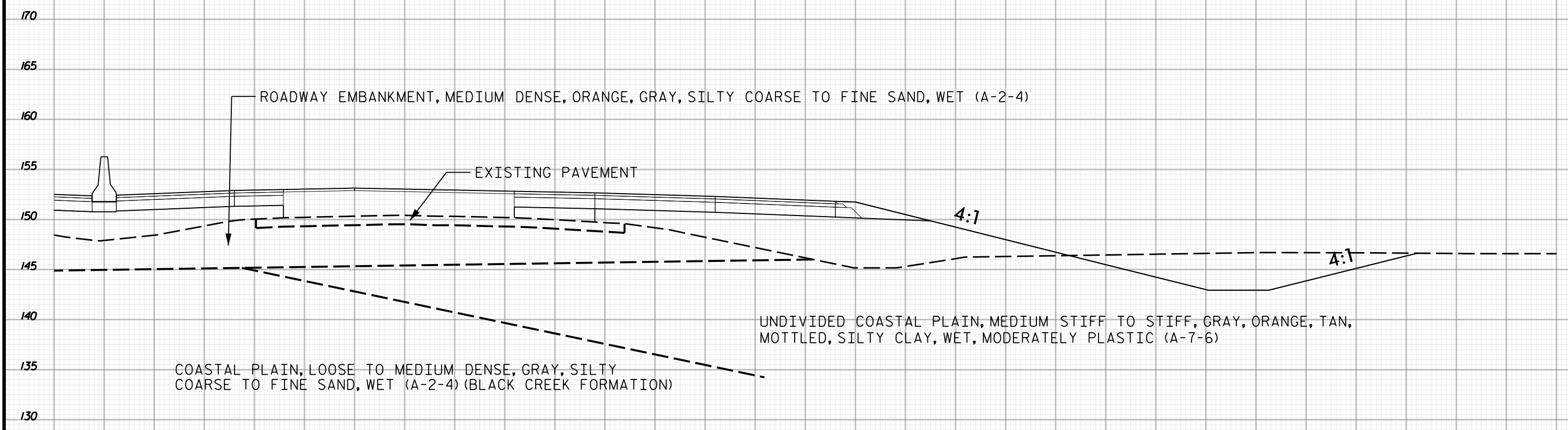

349+50  
2 OF 2

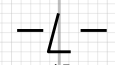

5 0 5 10 15 20 25 30 35 40 45 50 55 60 65 70 75 80 85 90 95 100 105 110 115 120 125 130 135 140 145

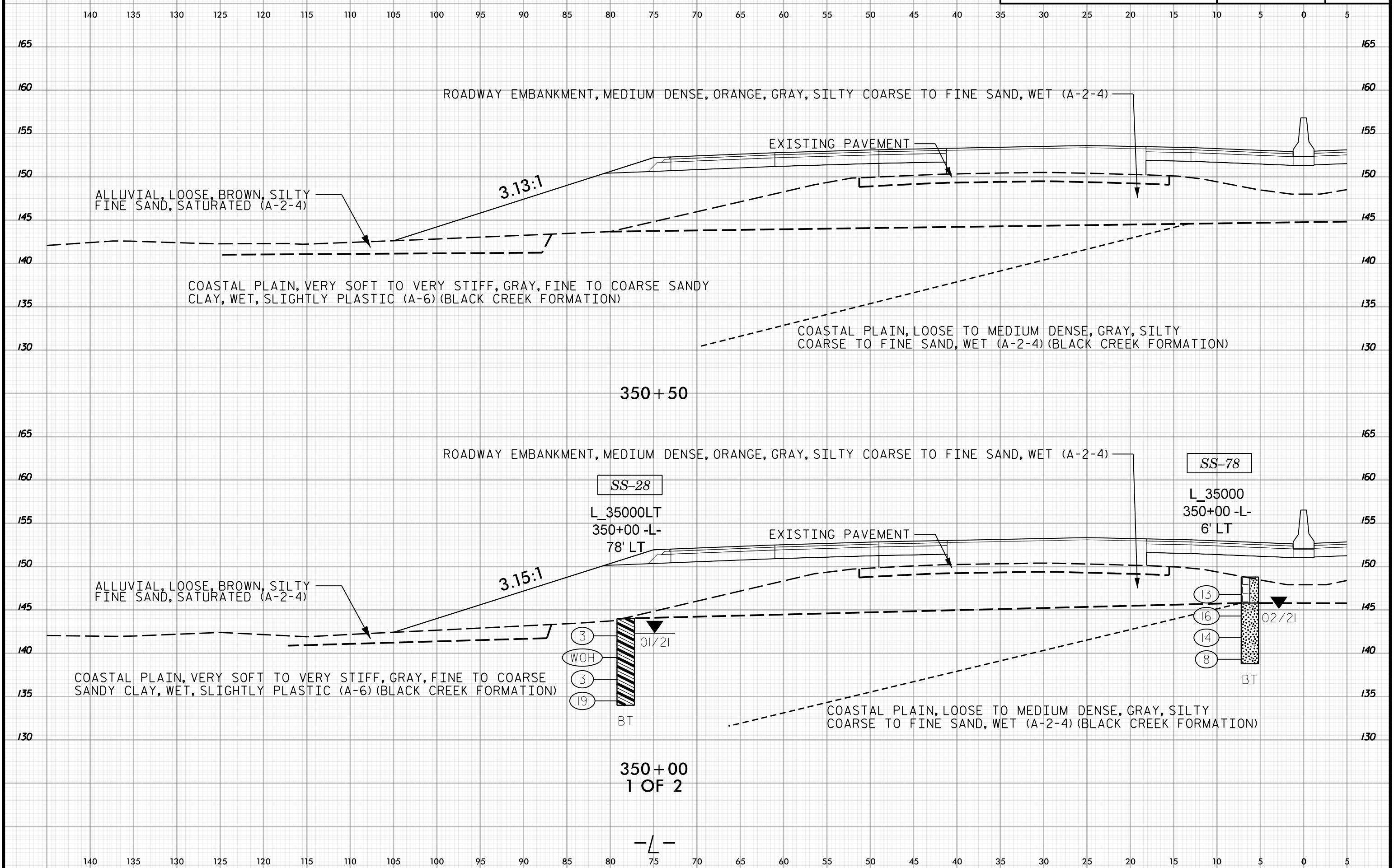

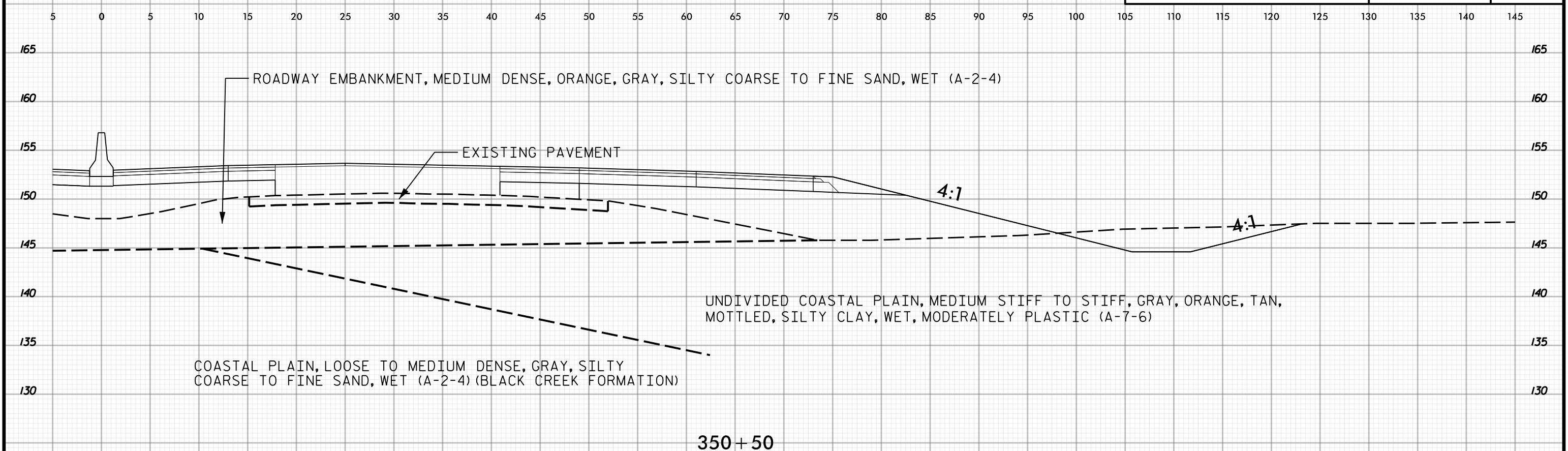

350+50

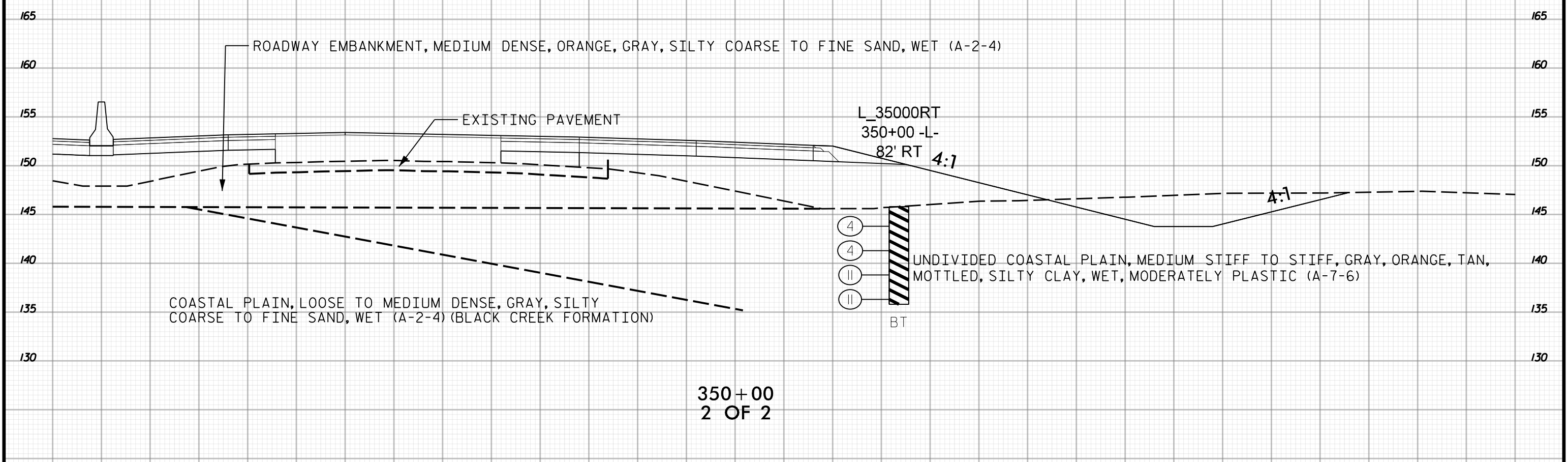

L\_35000RT  
350+00 -L-  
82' RT

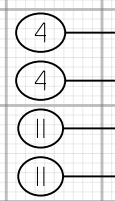

BT

350+00  
2 OF 2

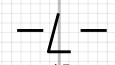





140 135 130 125 120 115 110 105 100 95 90 85 80 75 70 65 60 55 50 45 40 35 30 25 20 15 10 5 0 5

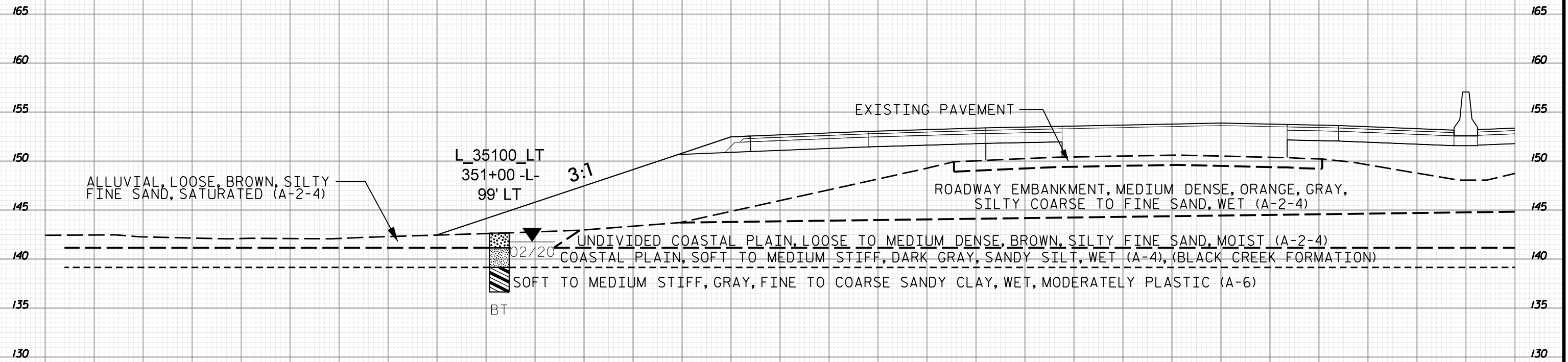

351+00  
1 OF 2

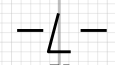

140 135 130 125 120 115 110 105 100 95 90 85 80 75 70 65 60 55 50 45 40 35 30 25 20 15 10 5 0 5



PROJ. REFERENCE NO.	SHEET NO.
I-5987A	599

5 0 5 10 15 20 25 30 35 40 45 50 55 60 65 70 75 80 85 90 95 100 105 110 115 120 125 130 135 140 145

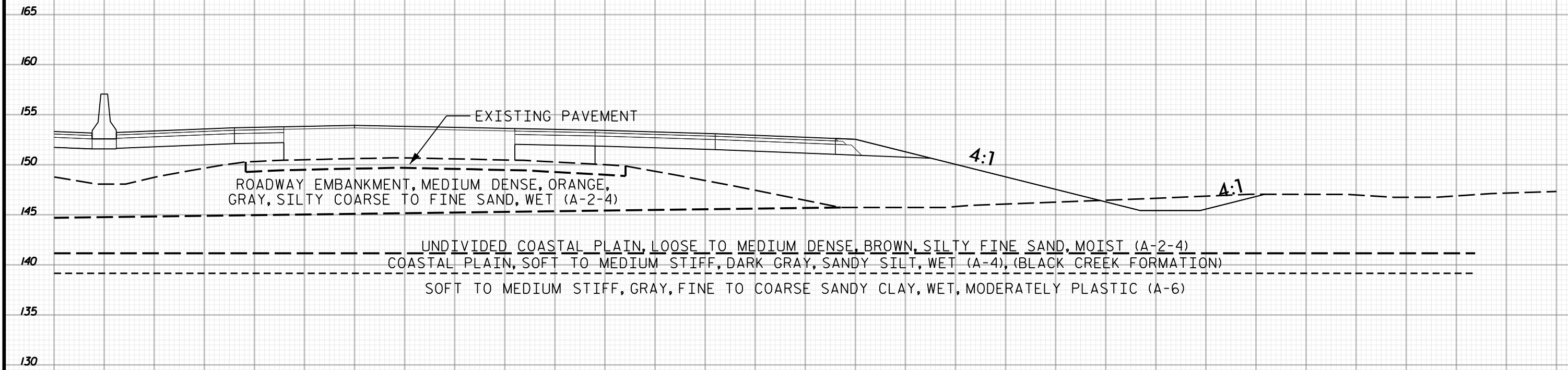

351+00  
2 OF 2

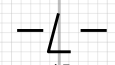

5 0 5 10 15 20 25 30 35 40 45 50 55 60 65 70 75 80 85 90 95 100 105 110 115 120 125 130 135 140 145



PROJ. REFERENCE NO.	SHEET NO.
I-5987A	600

140 135 130 125 120 115 110 105 100 95 90 85 80 75 70 65 60 55 50 45 40 35 30 25 20 15 10 5 0 5

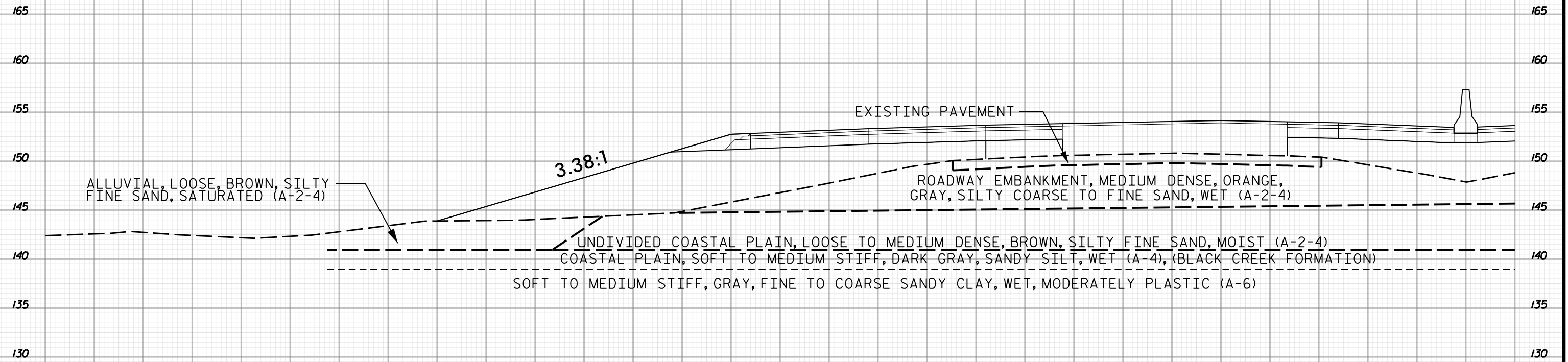

351+50  
1 OF 2

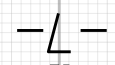

140 135 130 125 120 115 110 105 100 95 90 85 80 75 70 65 60 55 50 45 40 35 30 25 20 15 10 5 0 5

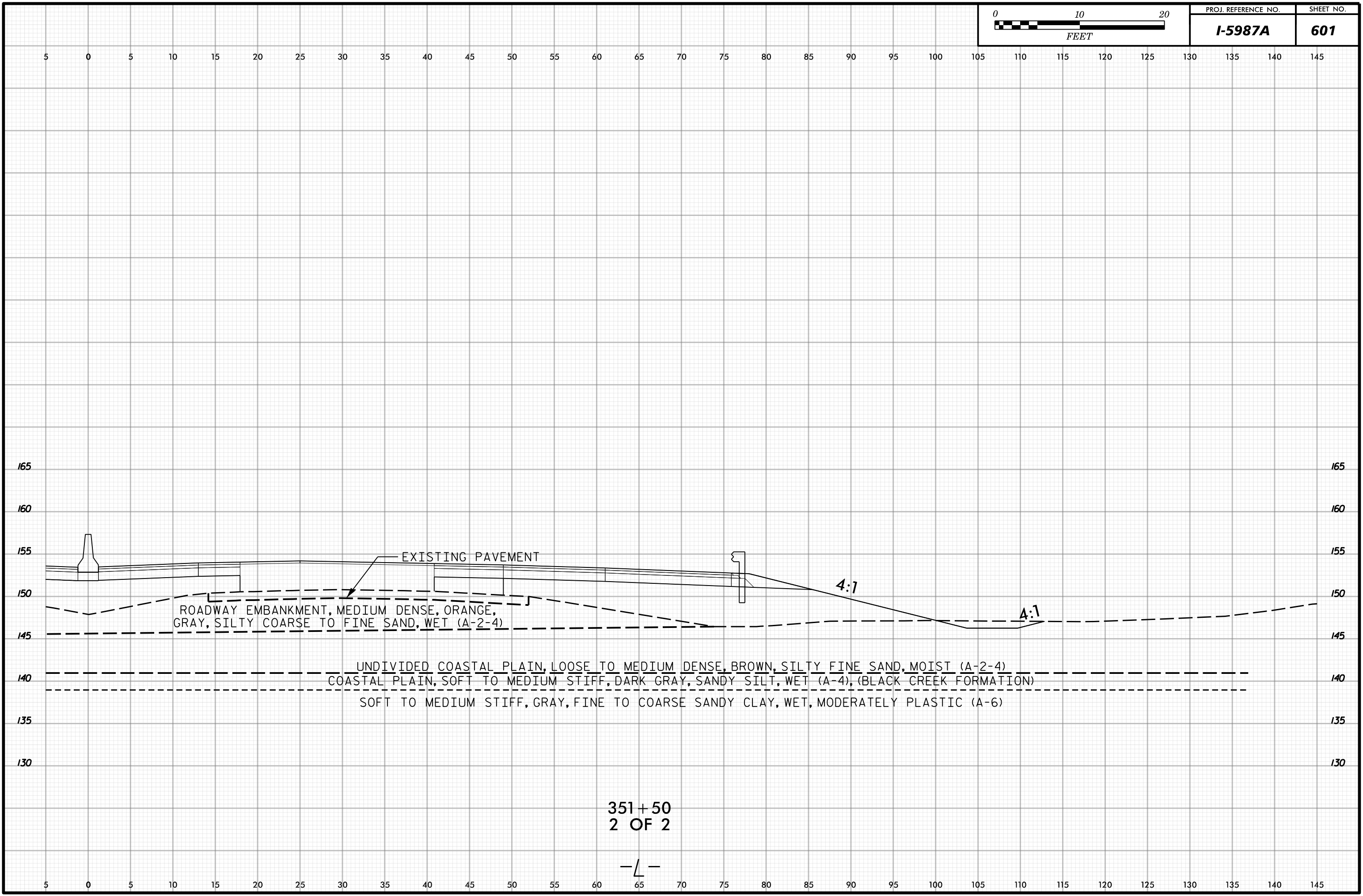

351+50  
2 OF 2

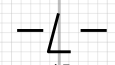

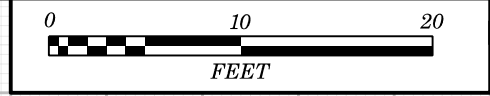

140 135 130 125 120 115 110 105 100 95 90 85 80 75 70 65 60 55 50 45 40 35 30 25 20 15 10 5 0 5

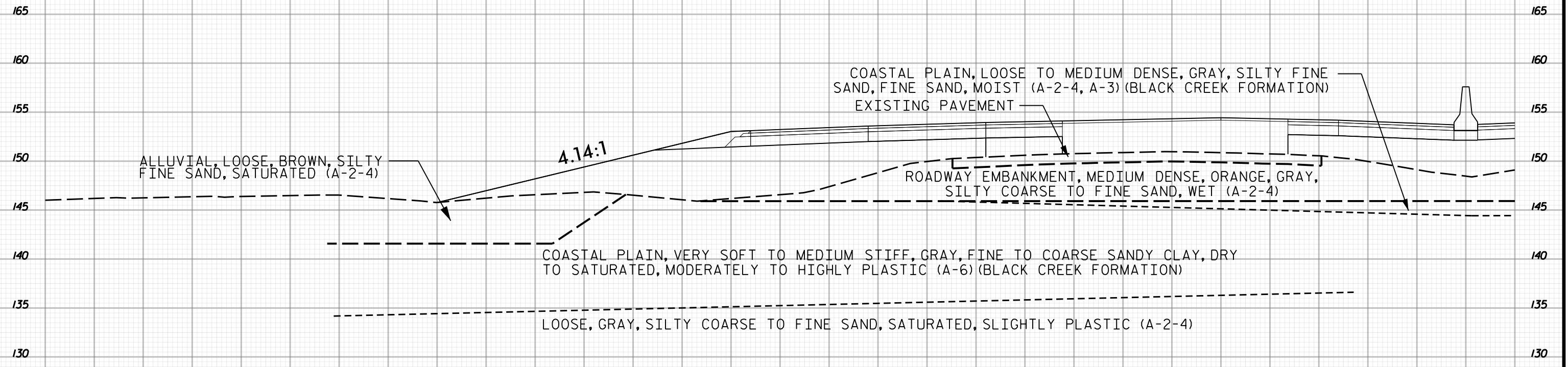

352+00  
1 OF 2

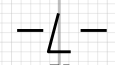

140 135 130 125 120 115 110 105 100 95 90 85 80 75 70 65 60 55 50 45 40 35 30 25 20 15 10 5 0 5



5 0 5 10 15 20 25 30 35 40 45 50 55 60 65 70 75 80 85 90 95 100 105 110 115 120 125 130 135 140 145

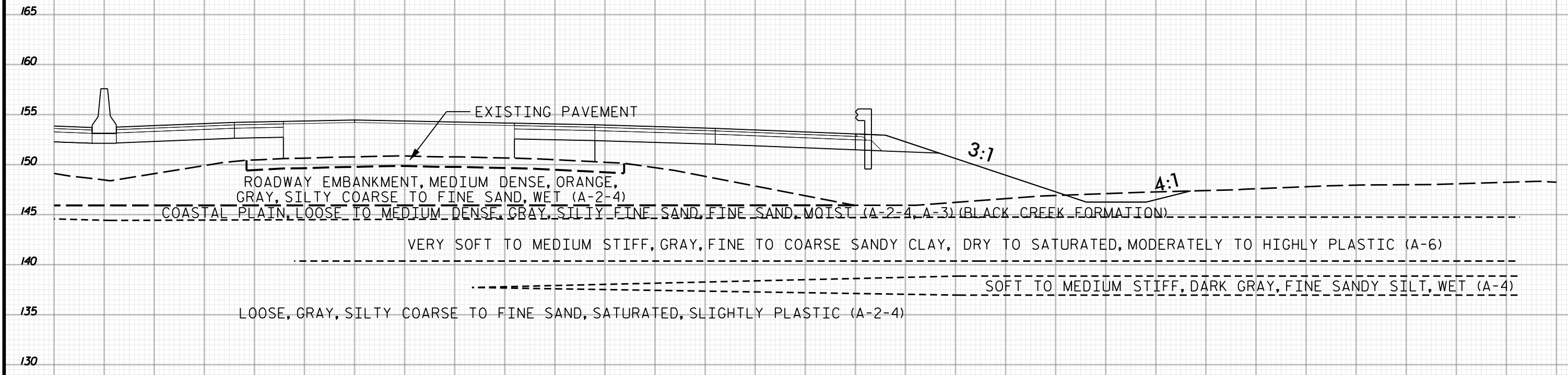

352+00  
2 OF 2

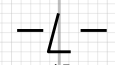

5 0 5 10 15 20 25 30 35 40 45 50 55 60 65 70 75 80 85 90 95 100 105 110 115 120 125 130 135 140 145

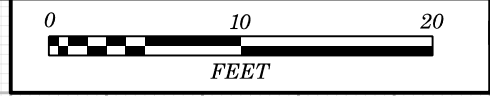

140 135 130 125 120 115 110 105 100 95 90 85 80 75 70 65 60 55 50 45 40 35 30 25 20 15 10 5 0 5

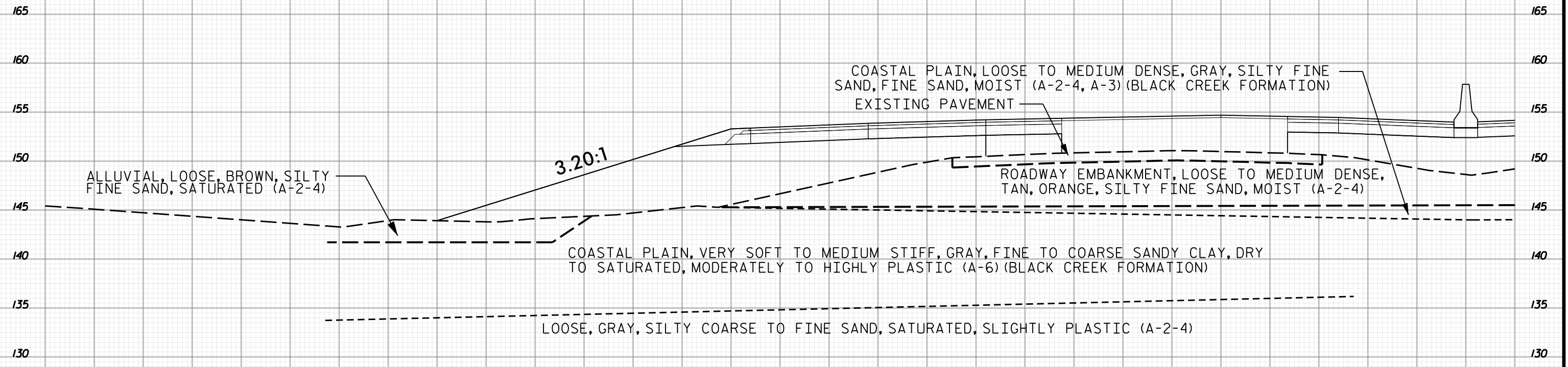

352 + 50  
1 OF 2

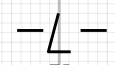

140 135 130 125 120 115 110 105 100 95 90 85 80 75 70 65 60 55 50 45 40 35 30 25 20 15 10 5 0 5



5 0 5 10 15 20 25 30 35 40 45 50 55 60 65 70 75 80 85 90 95 100 105 110 115 120 125 130 135 140 145

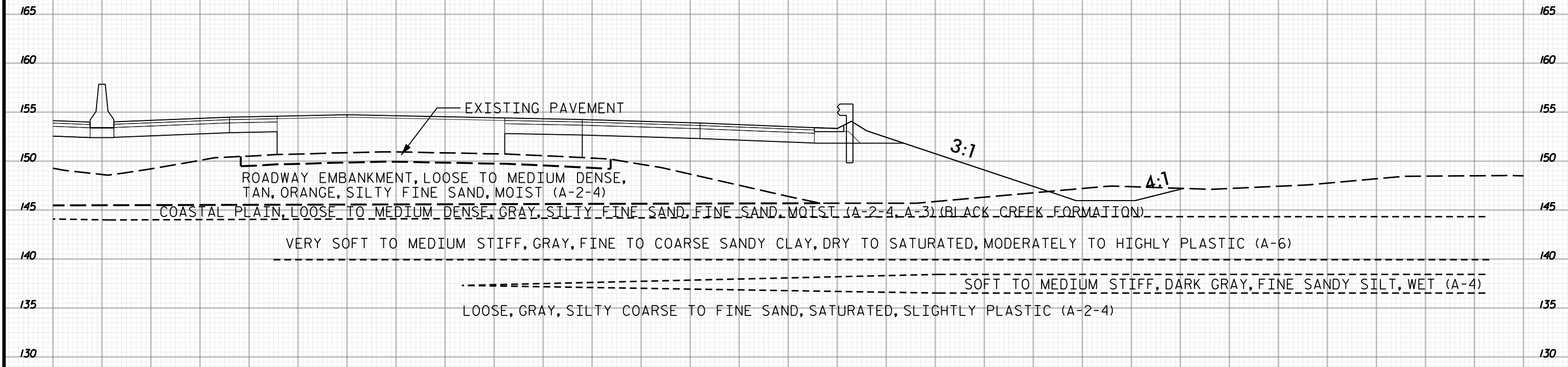

352+50  
2 OF 2

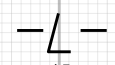

5 0 5 10 15 20 25 30 35 40 45 50 55 60 65 70 75 80 85 90 95 100 105 110 115 120 125 130 135 140 145



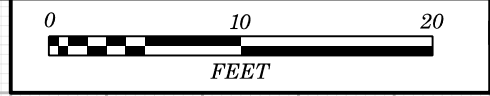

140 135 130 125 120 115 110 105 100 95 90 85 80 75 70 65 60 55 50 45 40 35 30 25 20 15 10 5 0 5

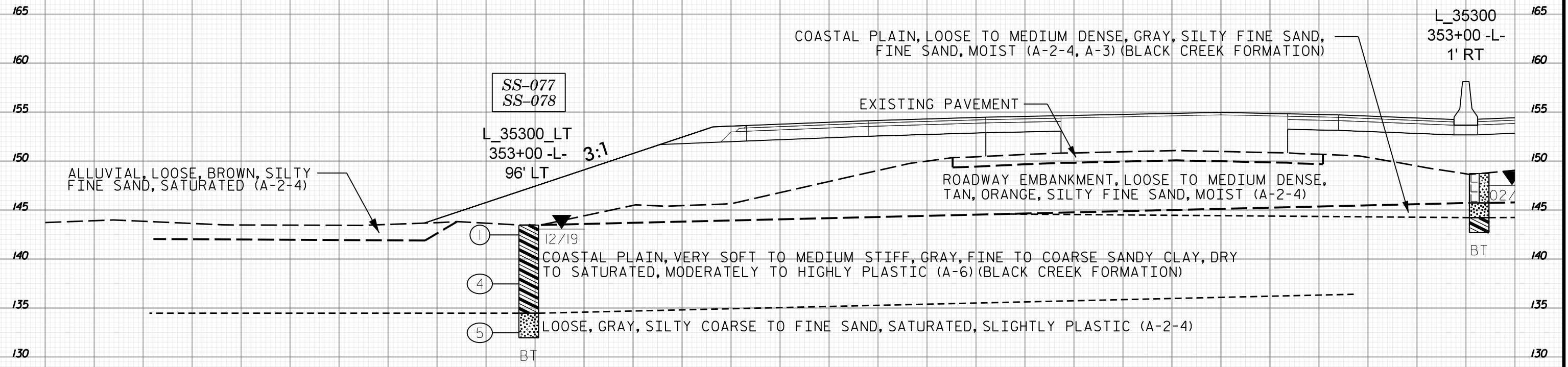

353+00  
1 OF 2

140 135 130 125 120 115 110 105 100 95 90 85 80 75 70 65 60 55 50 45 40 35 30 25 20 15 10 5 0 5



5 0 5 10 15 20 25 30 35 40 45 50 55 60 65 70 75 80 85 90 95 100 105 110 115 120 125 130 135 140 145

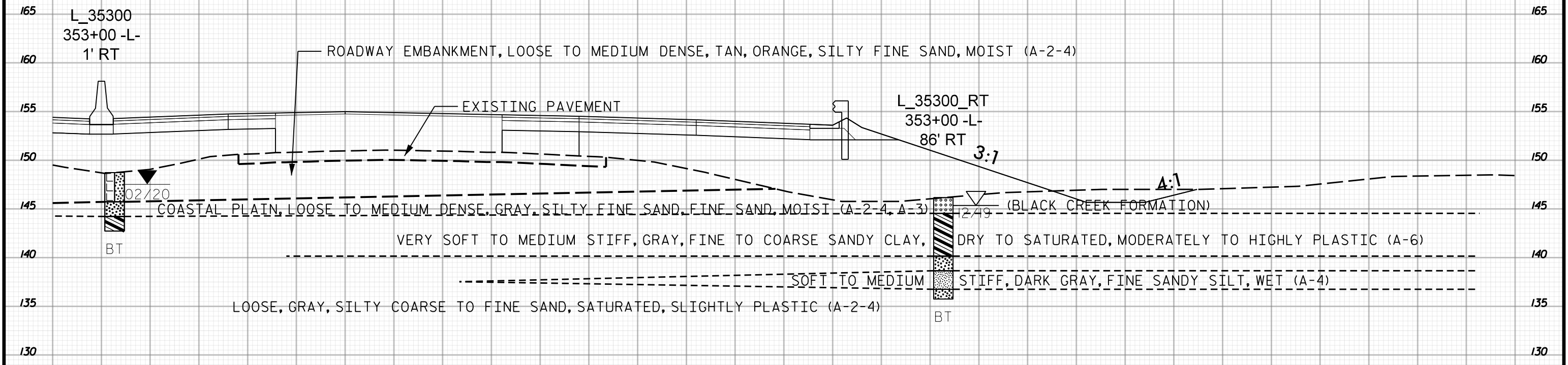

353+00  
2 OF 2

-L-

5 0 5 10 15 20 25 30 35 40 45 50 55 60 65 70 75 80 85 90 95 100 105 110 115 120 125 130 135 140 145

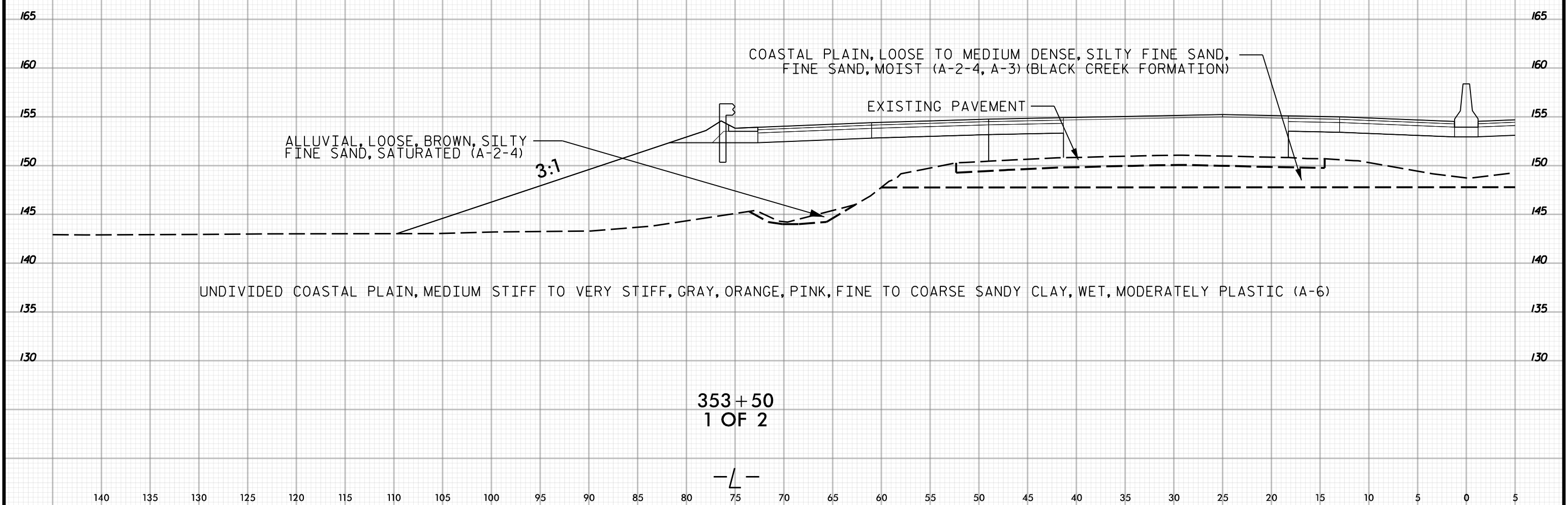
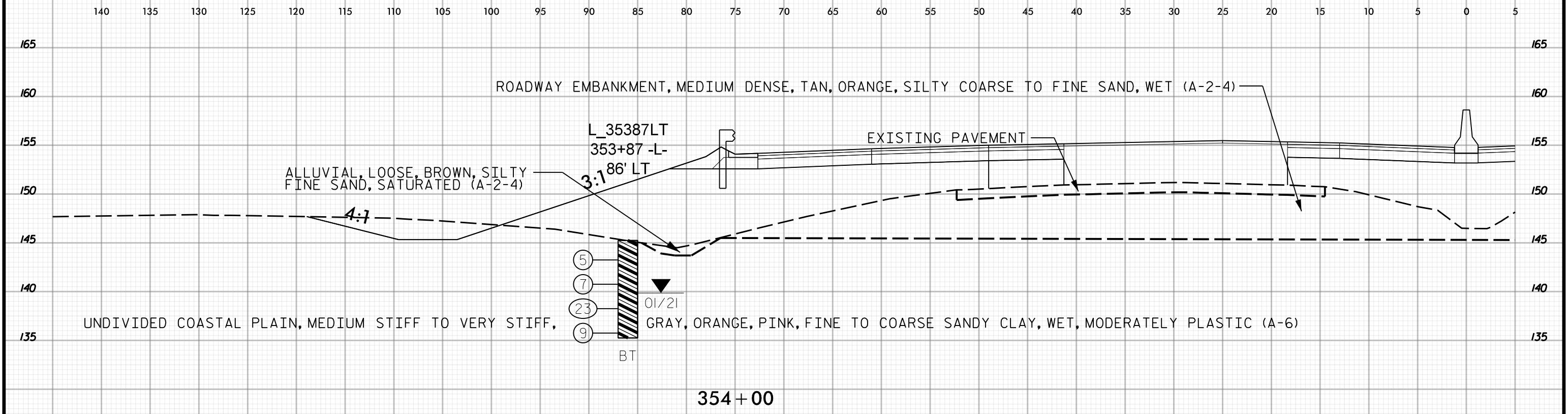

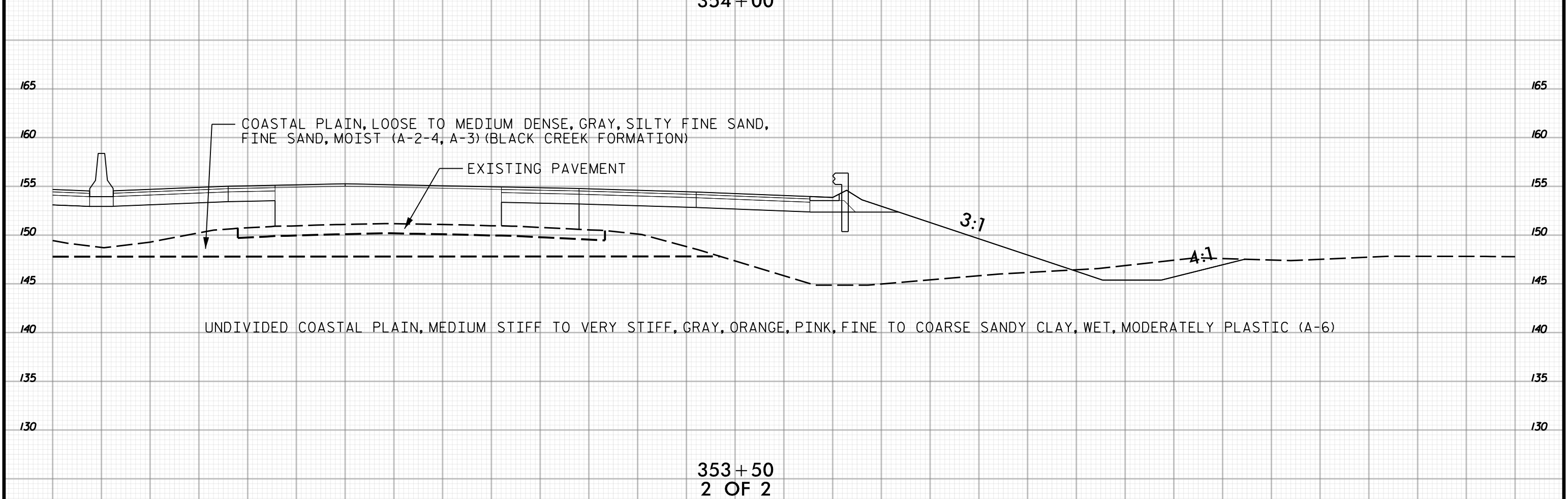
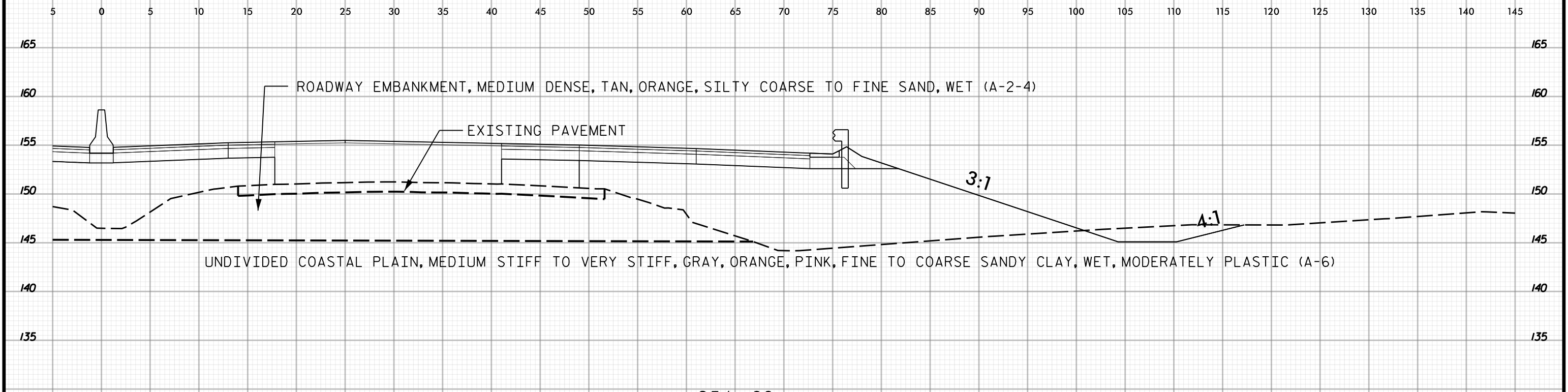

2 OF 2

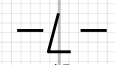

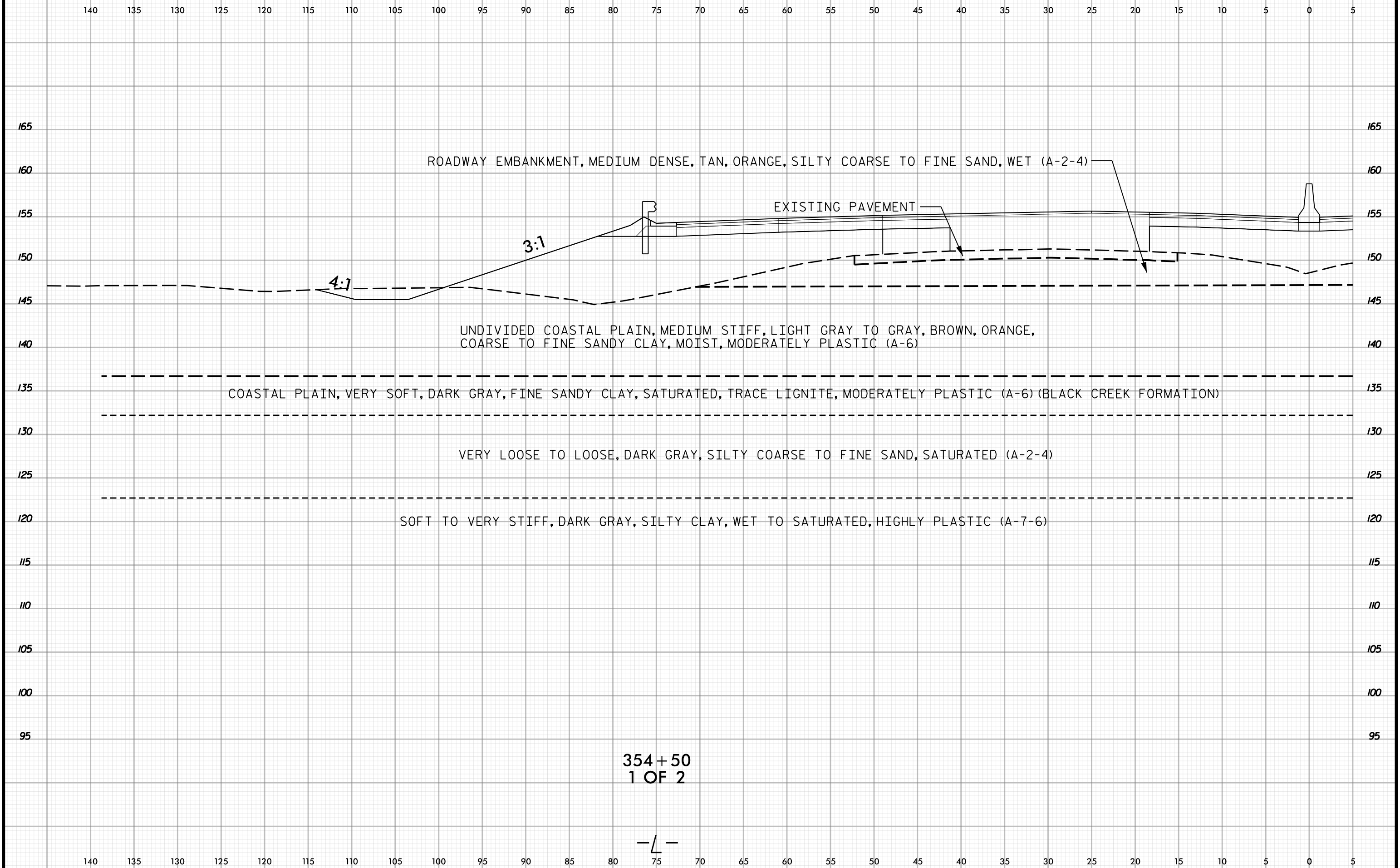

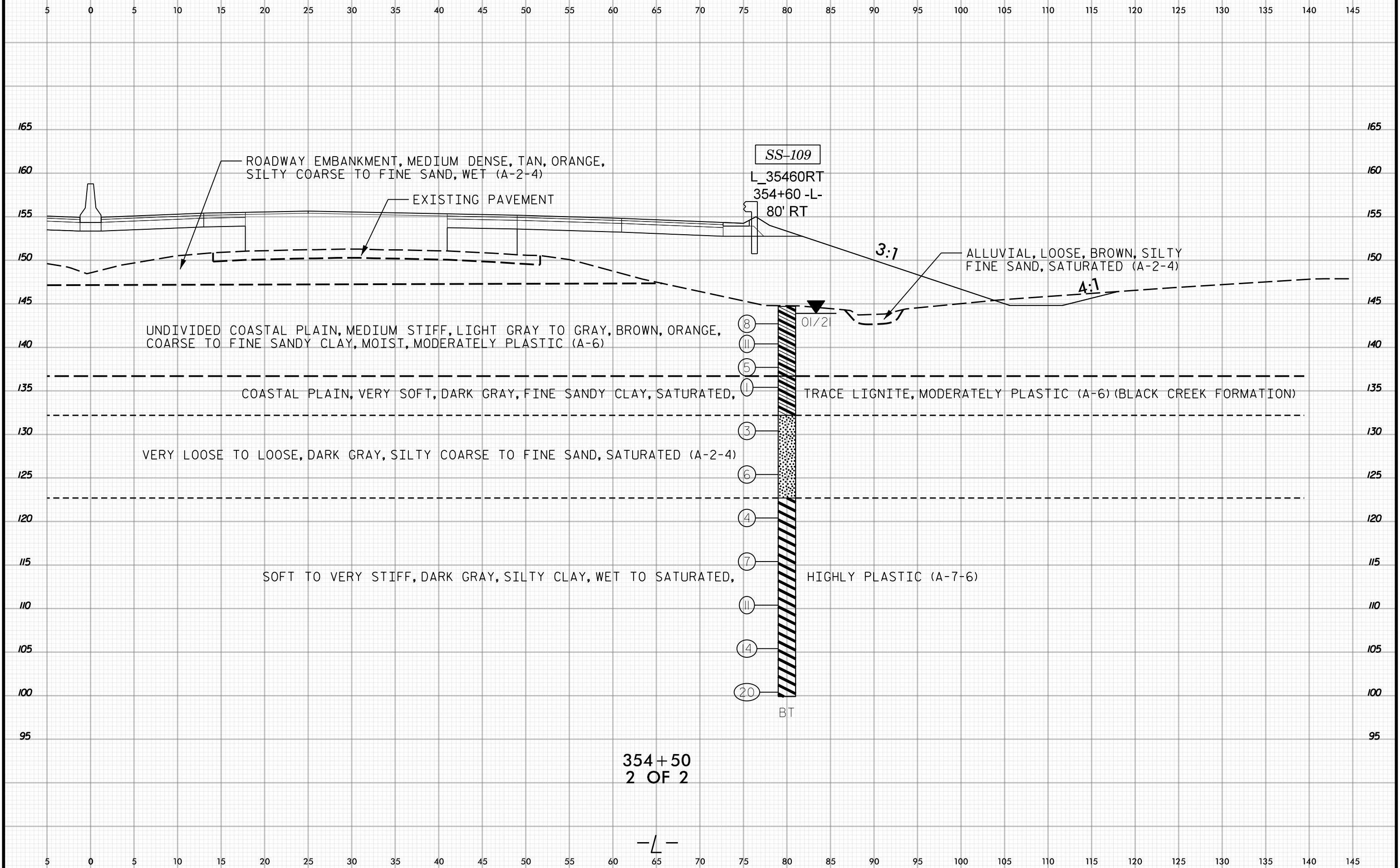



140 135 130 125 120 115 110 105 100 95 90 85 80 75 70 65 60 55 50 45 40 35 30 25 20 15 10 5 0 5

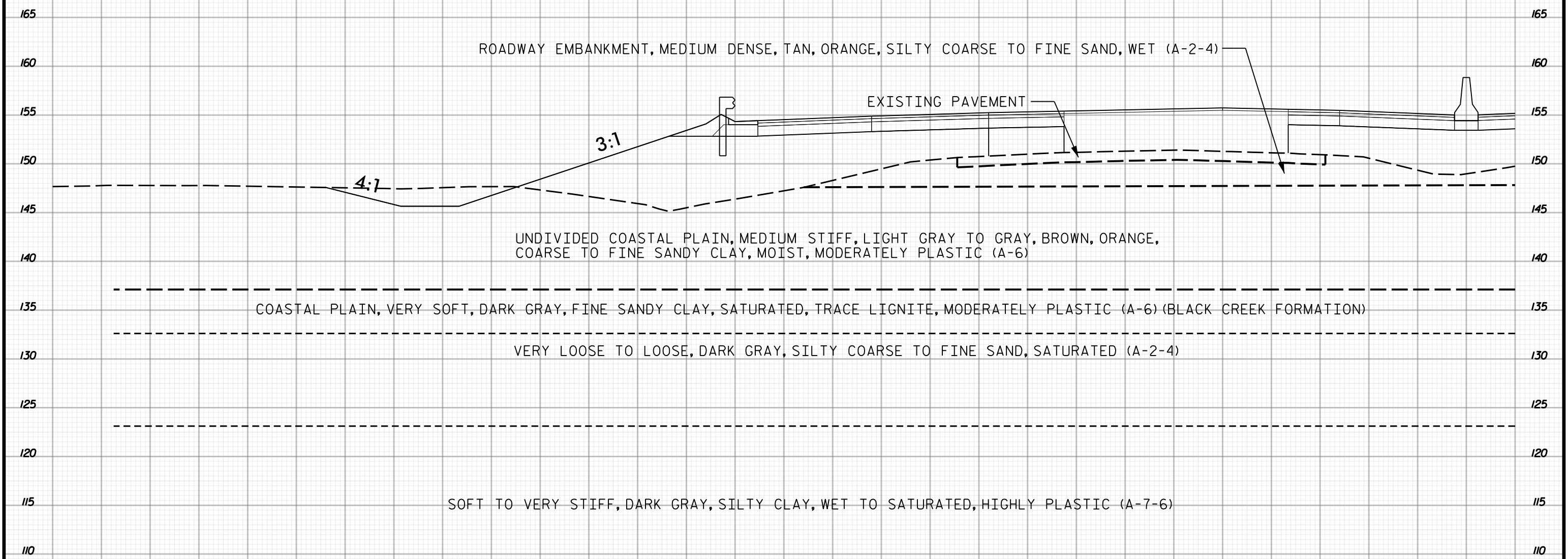

355+00  
1 OF 2

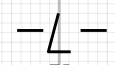

140 135 130 125 120 115 110 105 100 95 90 85 80 75 70 65 60 55 50 45 40 35 30 25 20 15 10 5 0 5

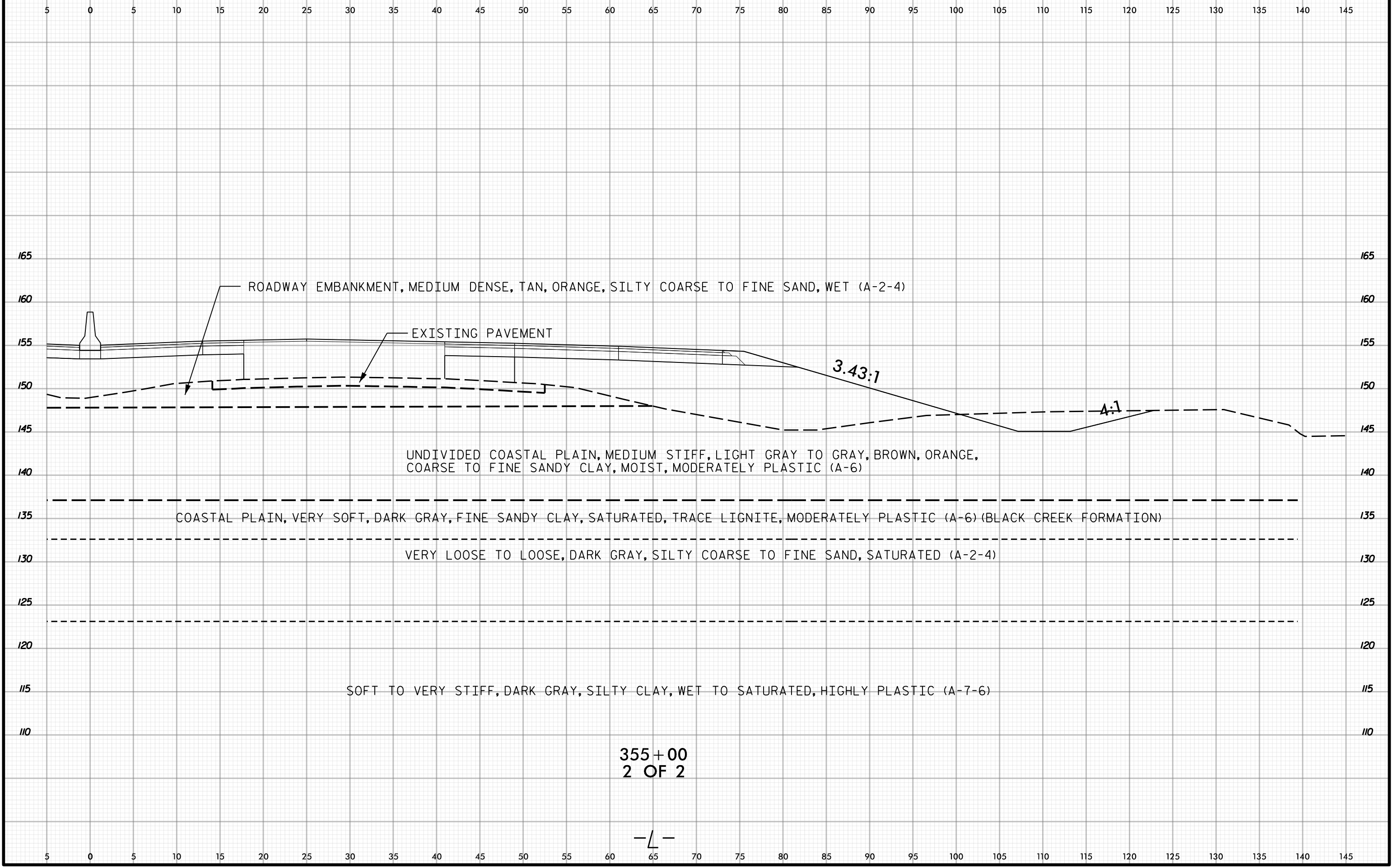
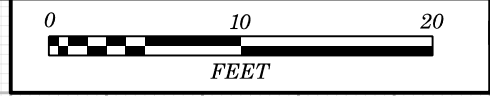

355+00  
2 OF 2

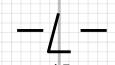





140 135 130 125 120 115 110 105 100 95 90 85 80 75 70 65 60 55 50 45 40 35 30 25 20 15 10 5 0 5

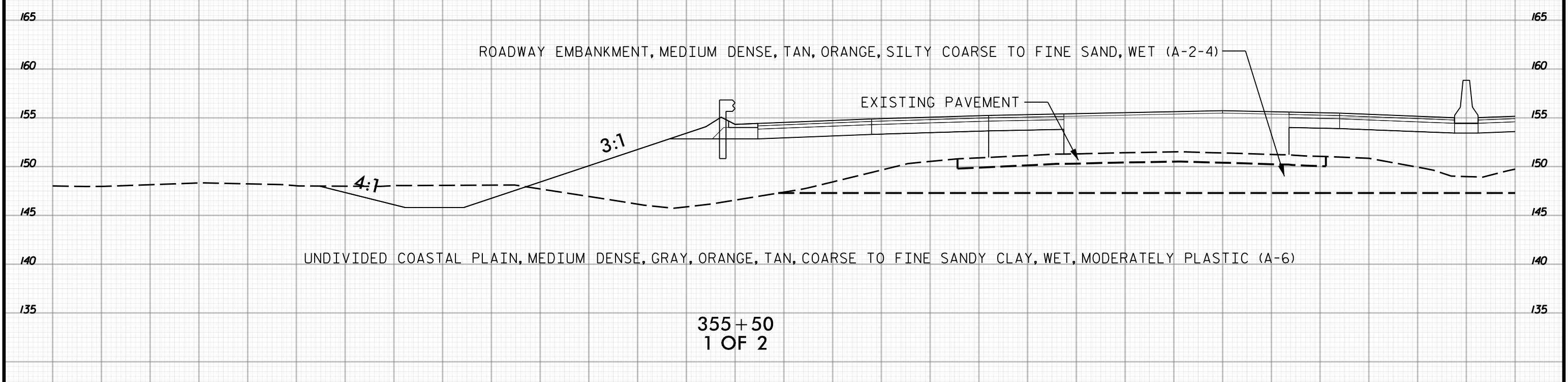
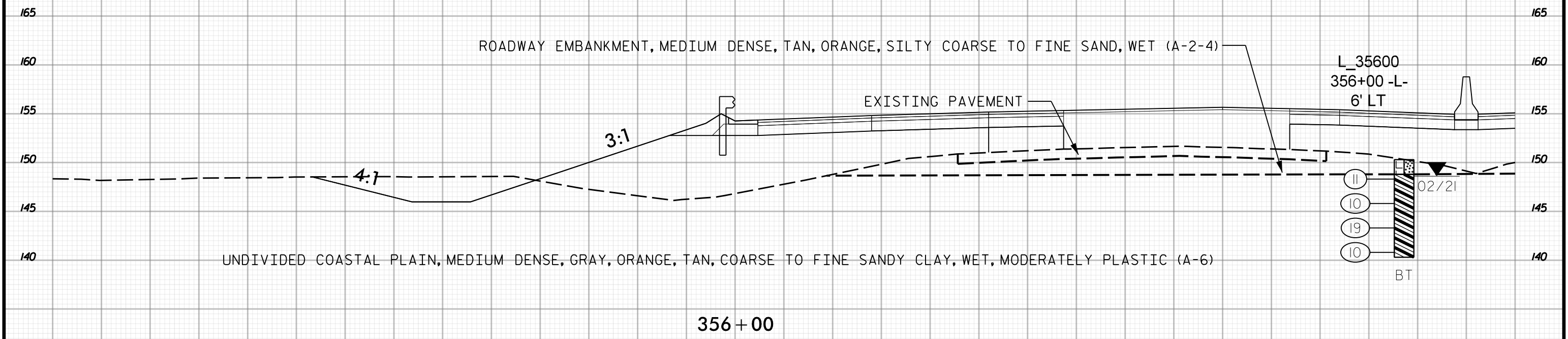

140 135 130 125 120 115 110 105 100 95 90 85 80 75 70 65 60 55 50 45 40 35 30 25 20 15 10 5 0 5

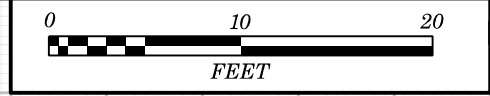

PROJ. REFERENCE NO.	SHEET NO.
I-5987A	615

5 0 5 10 15 20 25 30 35 40 45 50 55 60 65 70 75 80 85 90 95 100 105 110 115 120 125 130 135 140 145

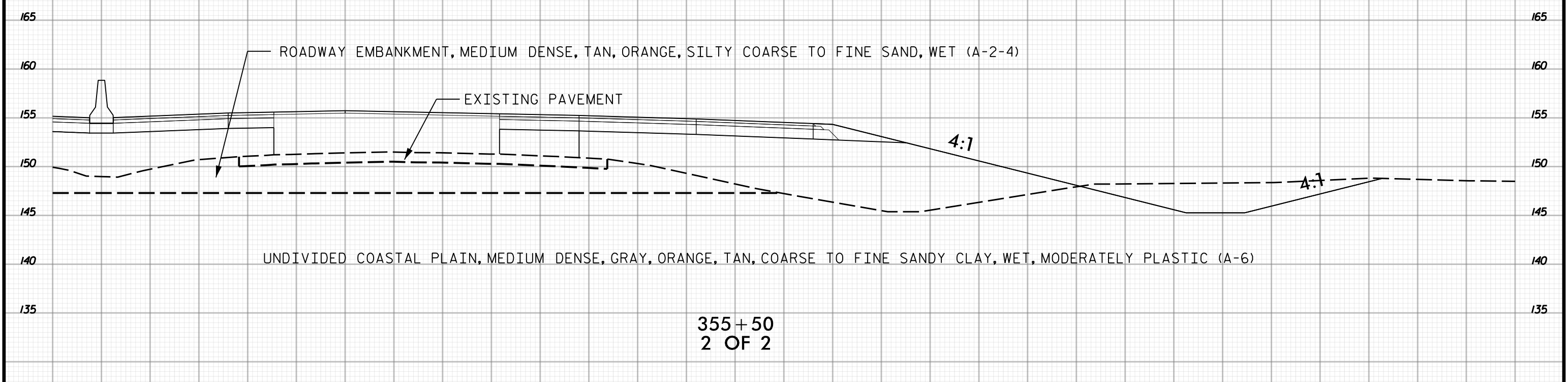
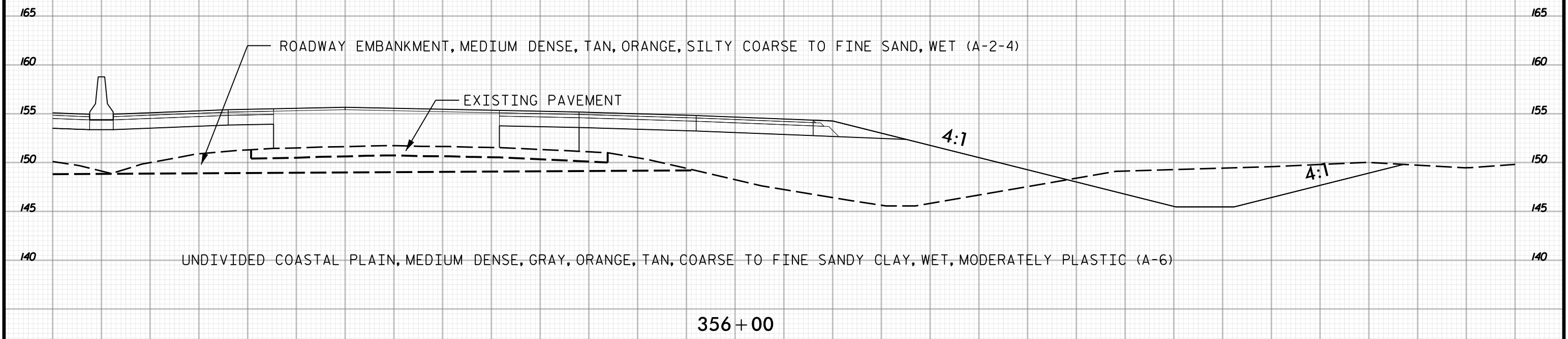

5 0 5 10 15 20 25 30 35 40 45 50 55 60 65 70 75 80 85 90 95 100 105 110 115 120 125 130 135 140 145

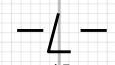



140 135 130 125 120 115 110 105 100 95 90 85 80 75 70 65 60 55 50 45 40 35 30 25 20 15 10 5 0 5

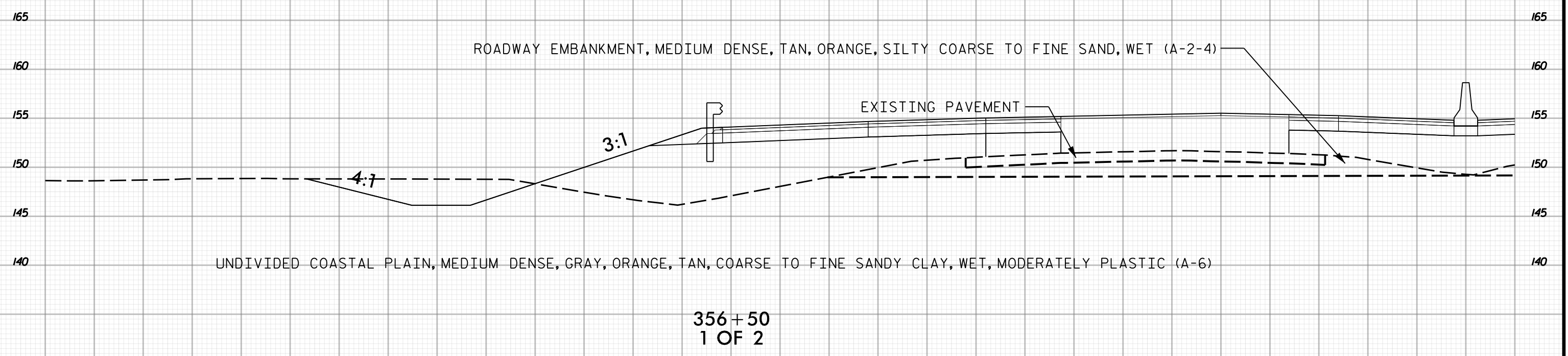
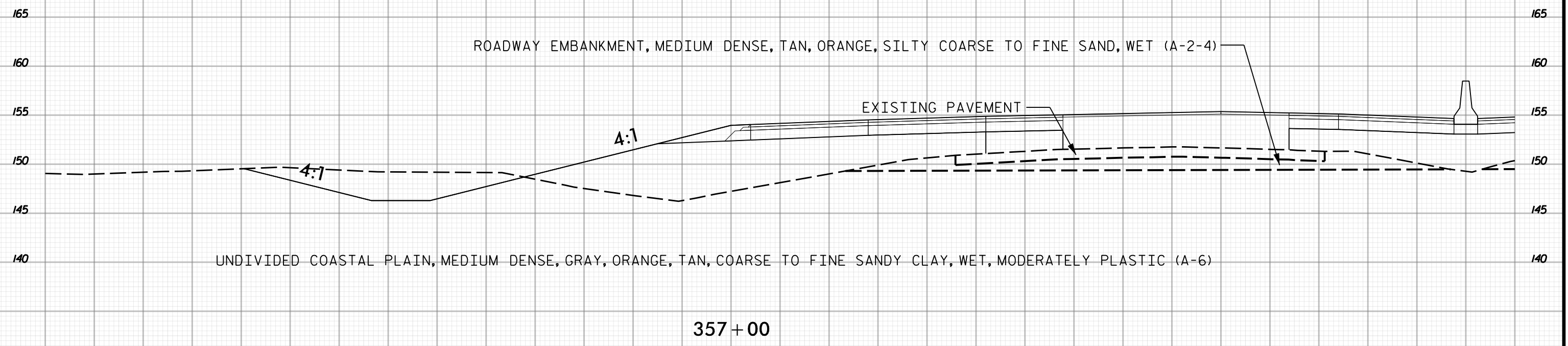

140 135 130 125 120 115 110 105 100 95 90 85 80 75 70 65 60 55 50 45 40 35 30 25 20 15 10 5 0 5

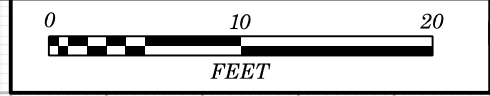

5 0 5 10 15 20 25 30 35 40 45 50 55 60 65 70 75 80 85 90 95 100 105 110 115 120 125 130 135 140 145

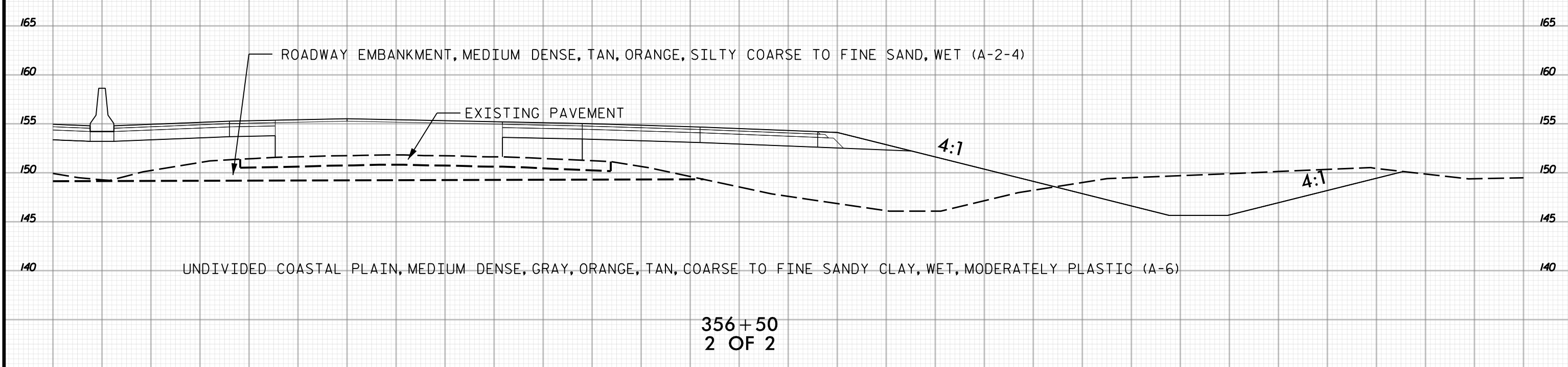
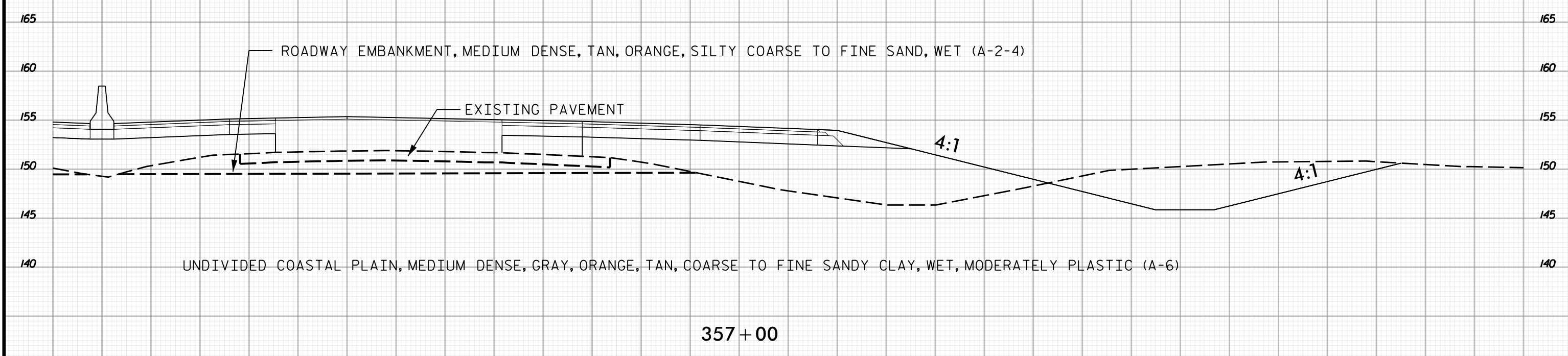

5 0 5 10 15 20 25 30 35 40 45 50 55 60 65 70 75 80 85 90 95 100 105 110 115 120 125 130 135 140 145

356+50  
2 OF 2

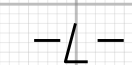

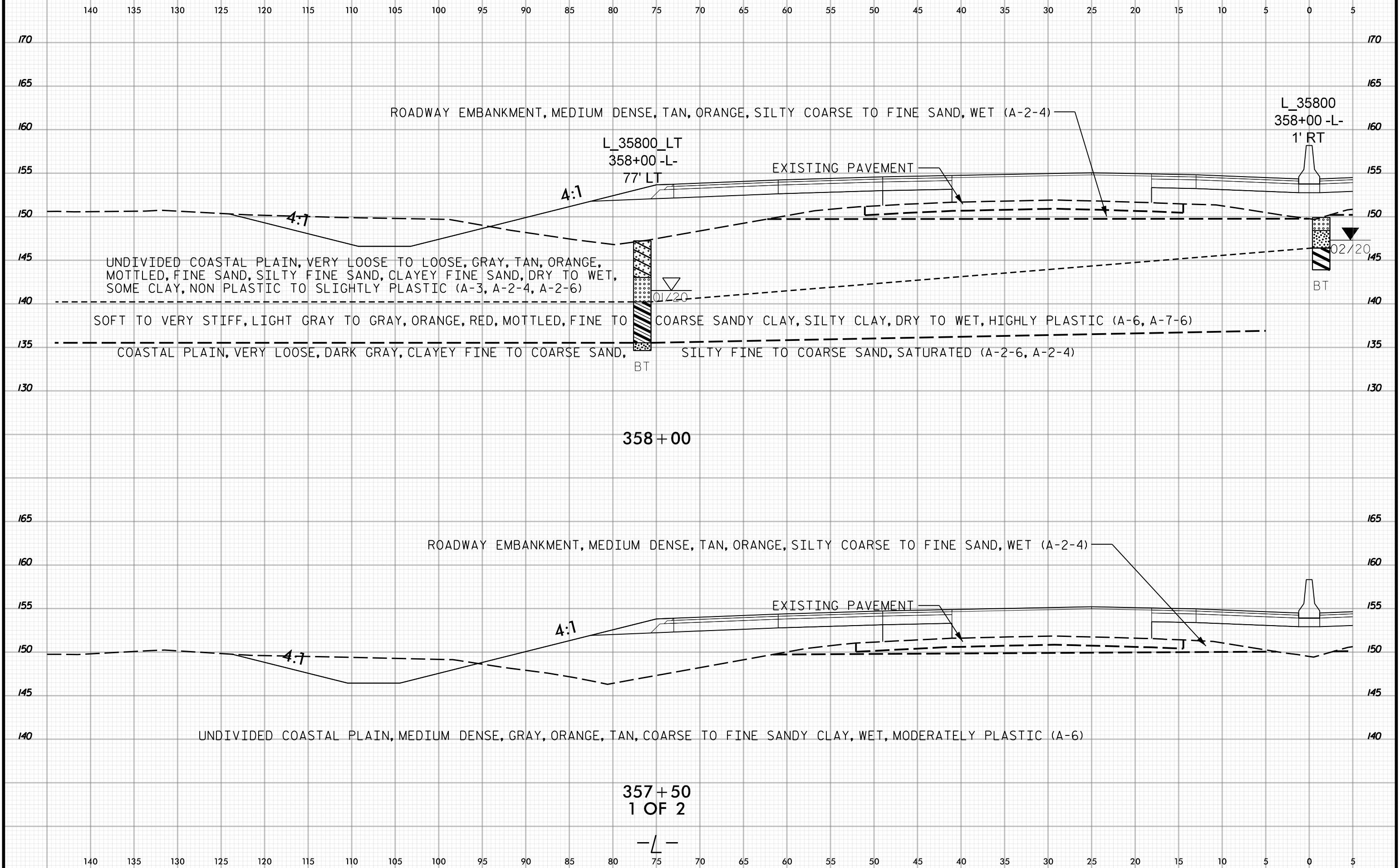

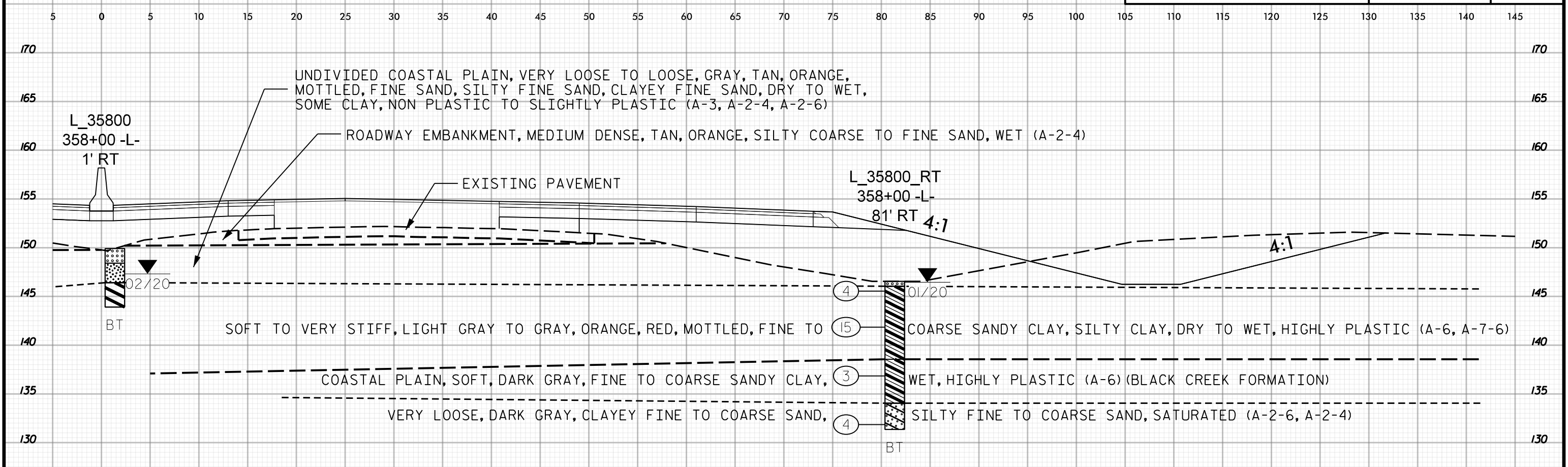

358+00

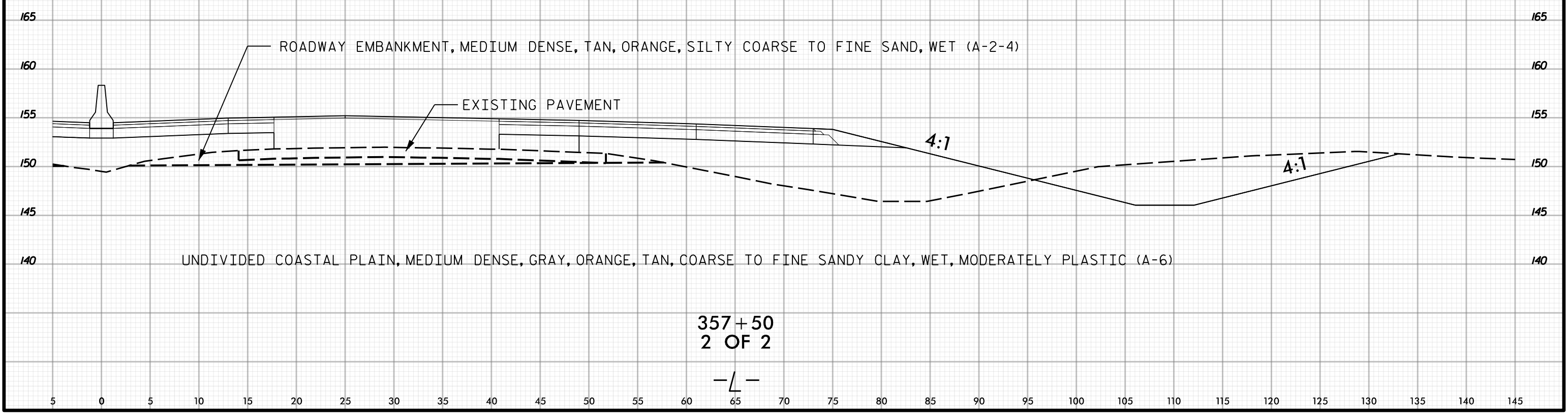

357+50  
2 OF 2

-L-

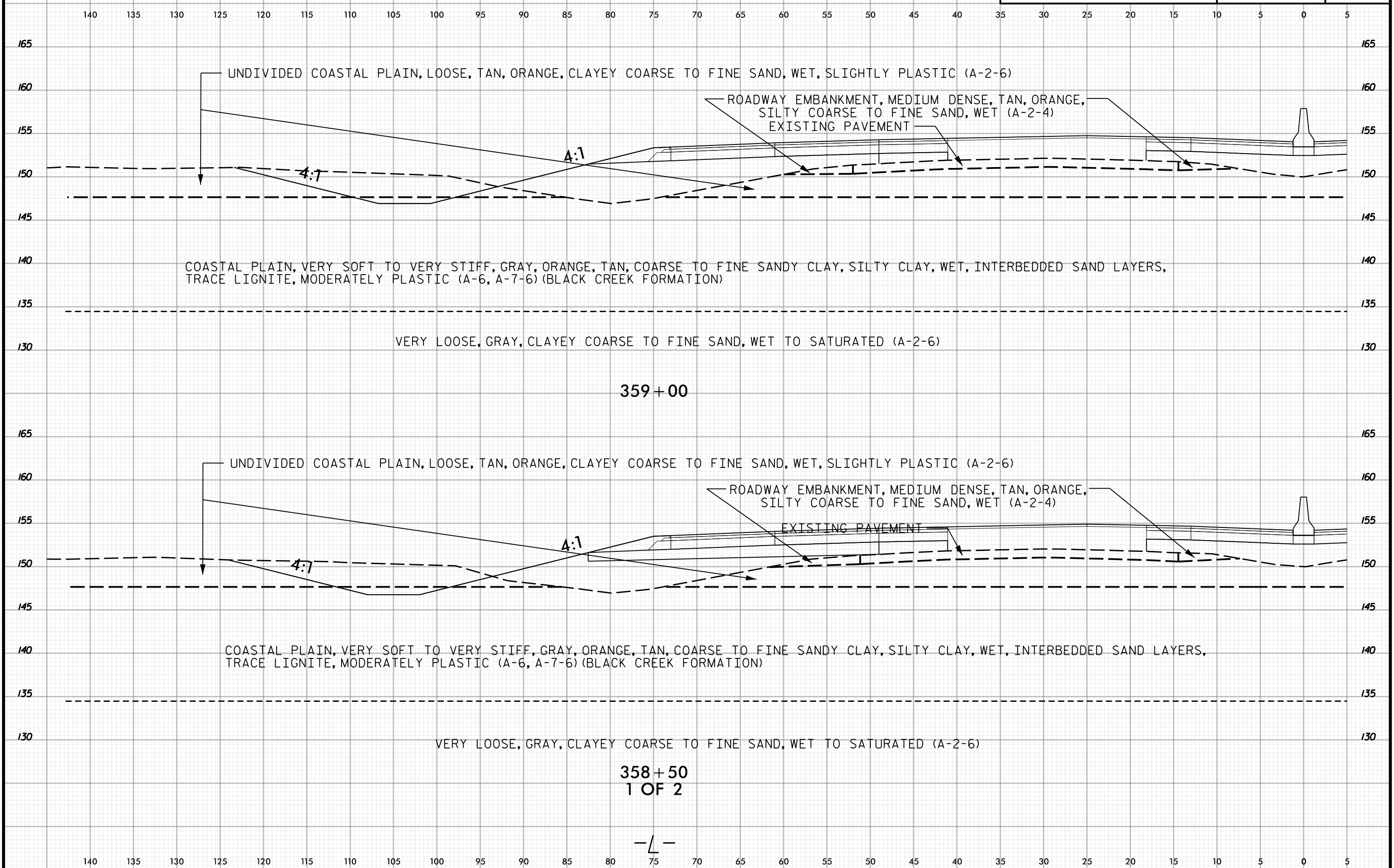

359+00

358+50  
1 OF 2

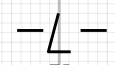

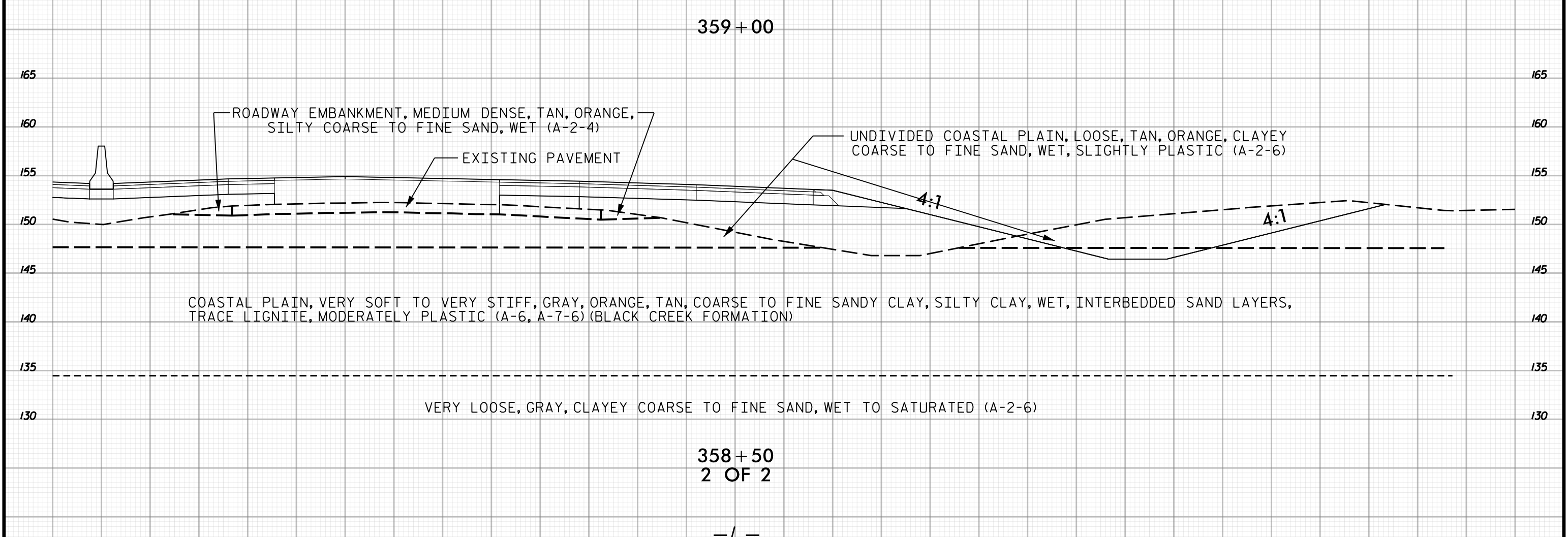
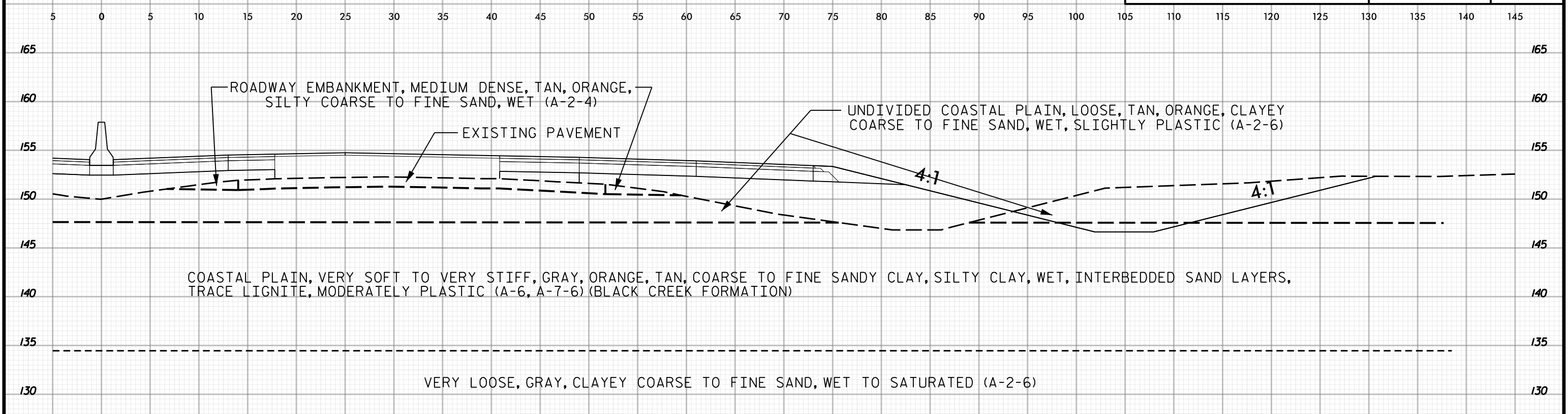

2 OF 2

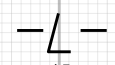





140 135 130 125 120 115 110 105 100 95 90 85 80 75 70 65 60 55 50 45 40 35 30 25 20 15 10 5 0 5

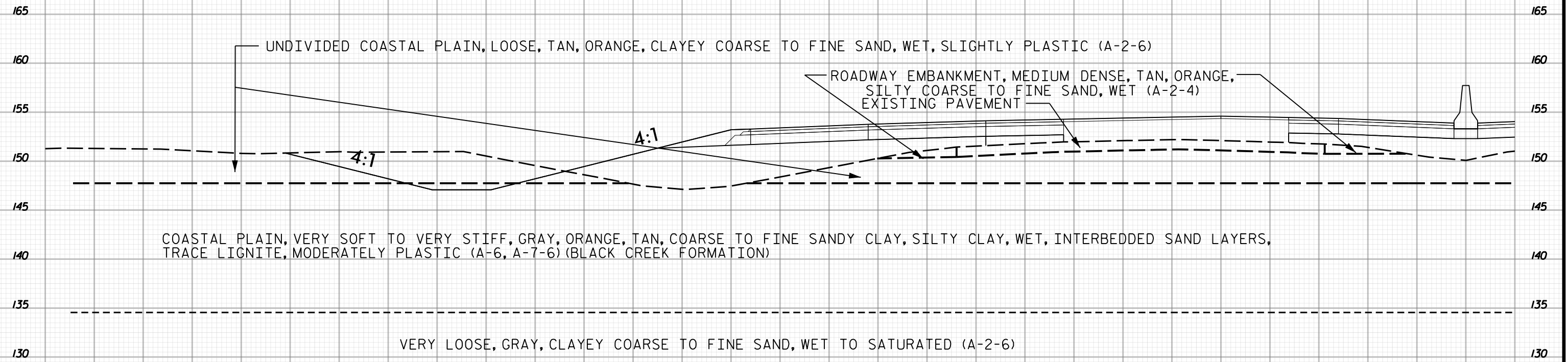

UNDIVIDED COASTAL PLAIN, LOOSE, TAN, ORANGE, CLAYEY COARSE TO FINE SAND, WET, SLIGHTLY PLASTIC (A-2-6)

ROADWAY EMBANKMENT, MEDIUM DENSE, TAN, ORANGE, SILTY COARSE TO FINE SAND, WET (A-2-4)  
EXISTING PAVEMENT

4:1

COASTAL PLAIN, VERY SOFT TO VERY STIFF, GRAY, ORANGE, TAN, COARSE TO FINE SANDY CLAY, SILTY CLAY, WET, INTERBEDDED SAND LAYERS, TRACE LIGNITE, MODERATELY PLASTIC (A-6, A-7-6) (BLACK CREEK FORMATION)

VERY LOOSE, GRAY, CLAYEY COARSE TO FINE SAND, WET TO SATURATED (A-2-6)

359 + 50  
1 OF 2

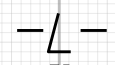

140 135 130 125 120 115 110 105 100 95 90 85 80 75 70 65 60 55 50 45 40 35 30 25 20 15 10 5 0 5



5 0 5 10 15 20 25 30 35 40 45 50 55 60 65 70 75 80 85 90 95 100 105 110 115 120 125 130 135 140 145

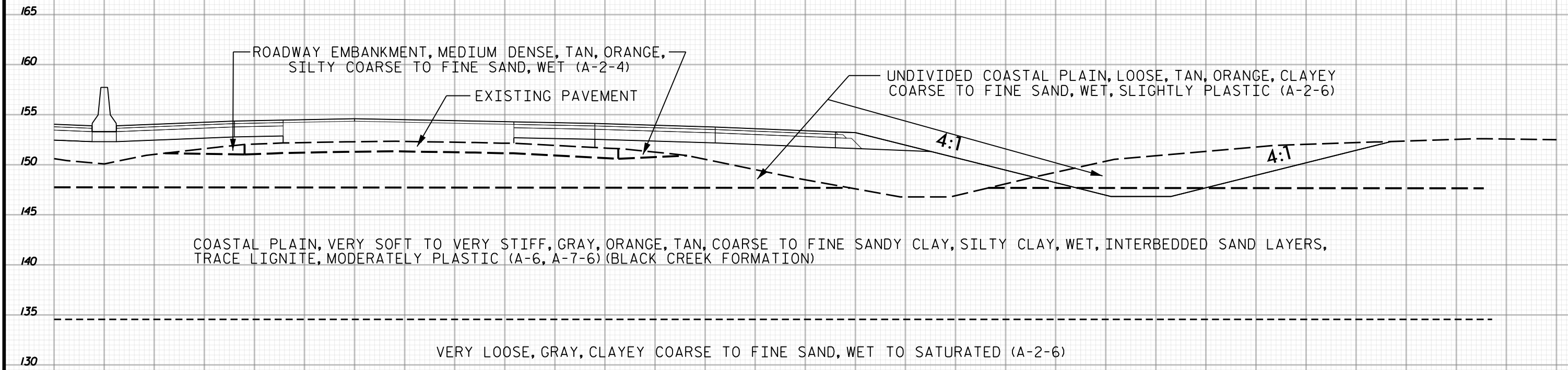

359 + 50  
2 OF 2

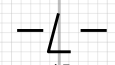

5 0 5 10 15 20 25 30 35 40 45 50 55 60 65 70 75 80 85 90 95 100 105 110 115 120 125 130 135 140 145



140 135 130 125 120 115 110 105 100 95 90 85 80 75 70 65 60 55 50 45 40 35 30 25 20 15 10 5 0 5

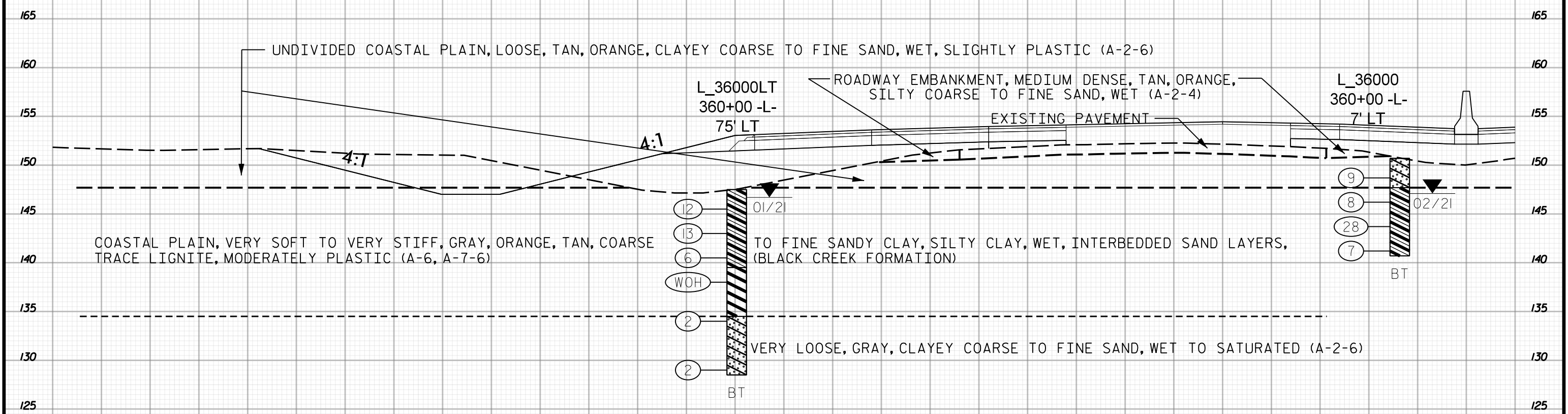

360+00  
1 OF 2

-L-

140 135 130 125 120 115 110 105 100 95 90 85 80 75 70 65 60 55 50 45 40 35 30 25 20 15 10 5 0 5



5 0 5 10 15 20 25 30 35 40 45 50 55 60 65 70 75 80 85 90 95 100 105 110 115 120 125 130 135 140 145

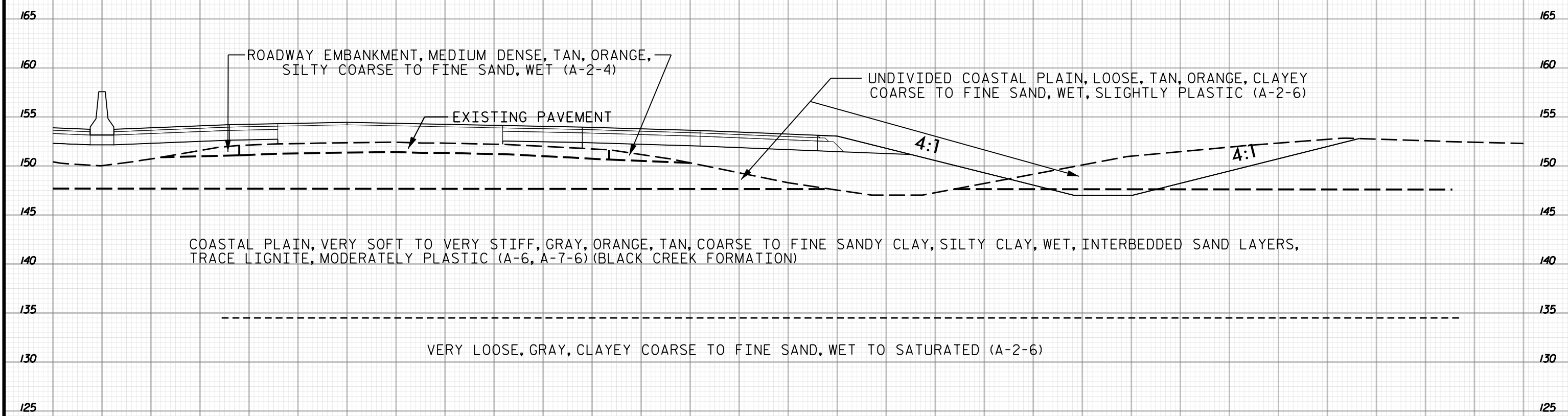

ROADWAY EMBANKMENT, MEDIUM DENSE, TAN, ORANGE, SILTY COARSE TO FINE SAND, WET (A-2-4)

EXISTING PAVEMENT

UNDIVIDED COASTAL PLAIN, LOOSE, TAN, ORANGE, CLAYEY COARSE TO FINE SAND, WET, SLIGHTLY PLASTIC (A-2-6)

4:1

4:1

COASTAL PLAIN, VERY SOFT TO VERY STIFF, GRAY, ORANGE, TAN, COARSE TO FINE SANDY CLAY, SILTY CLAY, WET, INTERBEDDED SAND LAYERS, TRACE LIGNITE, MODERATELY PLASTIC (A-6, A-7-6) (BLACK CREEK FORMATION)

VERY LOOSE, GRAY, CLAYEY COARSE TO FINE SAND, WET TO SATURATED (A-2-6)

360+00  
2 OF 2

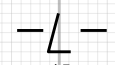

5 0 5 10 15 20 25 30 35 40 45 50 55 60 65 70 75 80 85 90 95 100 105 110 115 120 125 130 135 140 145

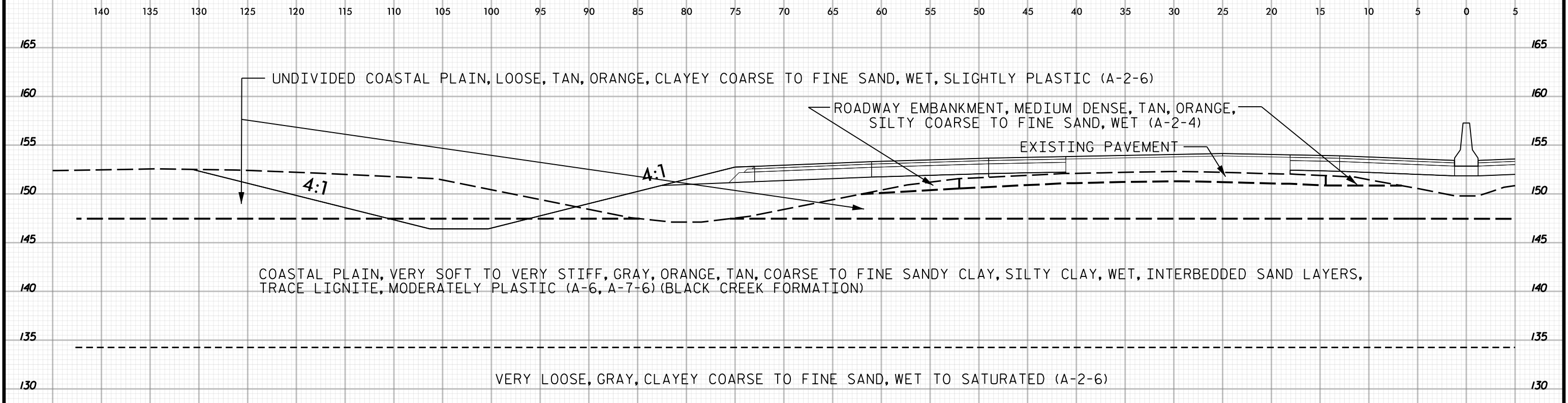

361+00

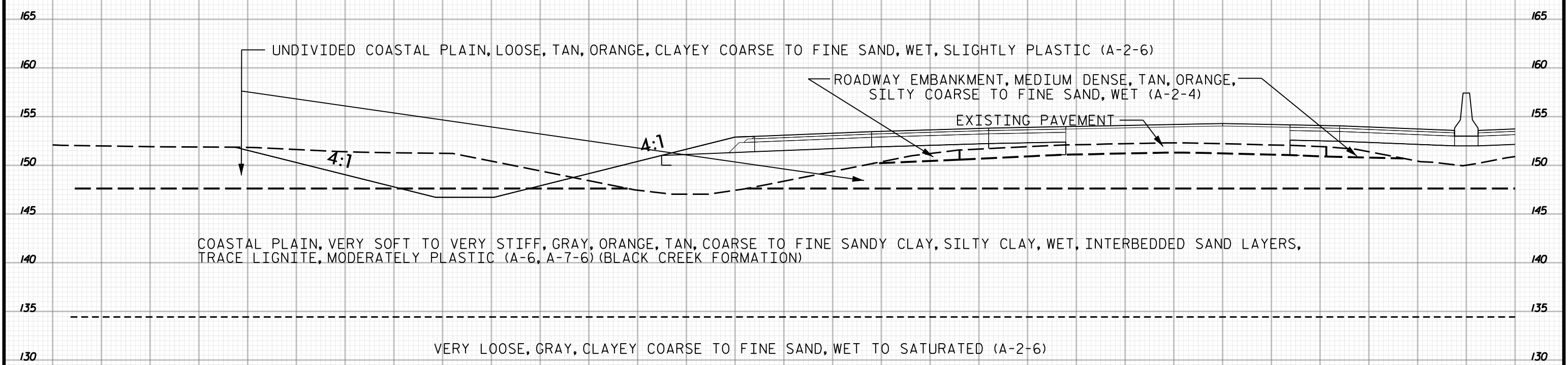

360+50  
1 OF 2

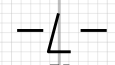

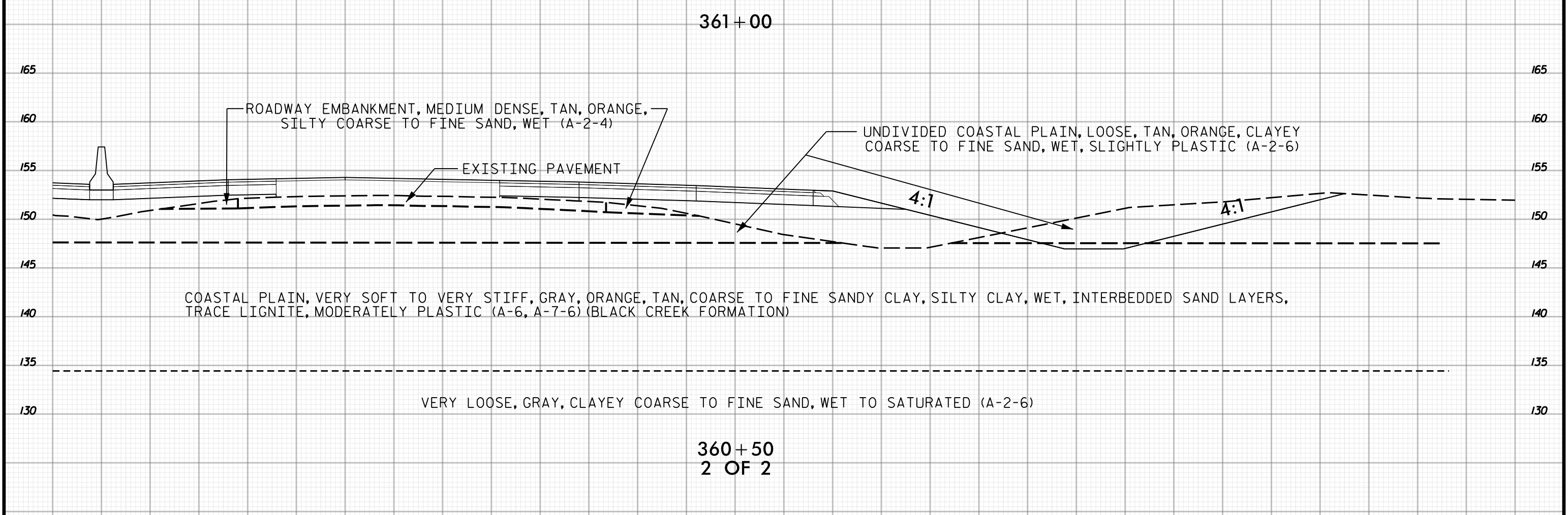
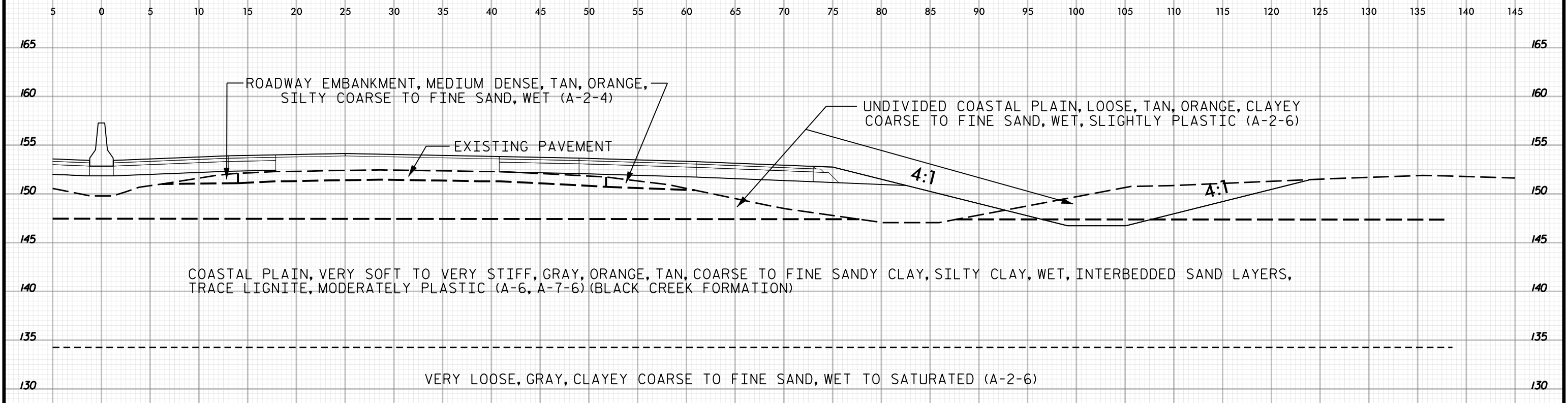



140 135 130 125 120 115 110 105 100 95 90 85 80 75 70 65 60 55 50 45 40 35 30 25 20 15 10 5 0 5

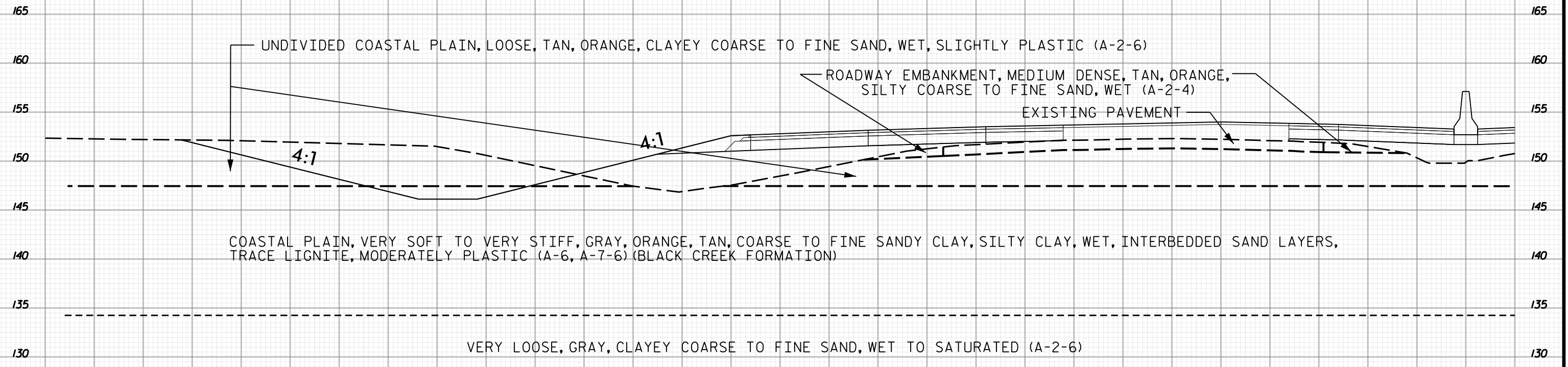

361+50  
1 OF 2

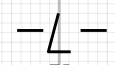

140 135 130 125 120 115 110 105 100 95 90 85 80 75 70 65 60 55 50 45 40 35 30 25 20 15 10 5 0 5

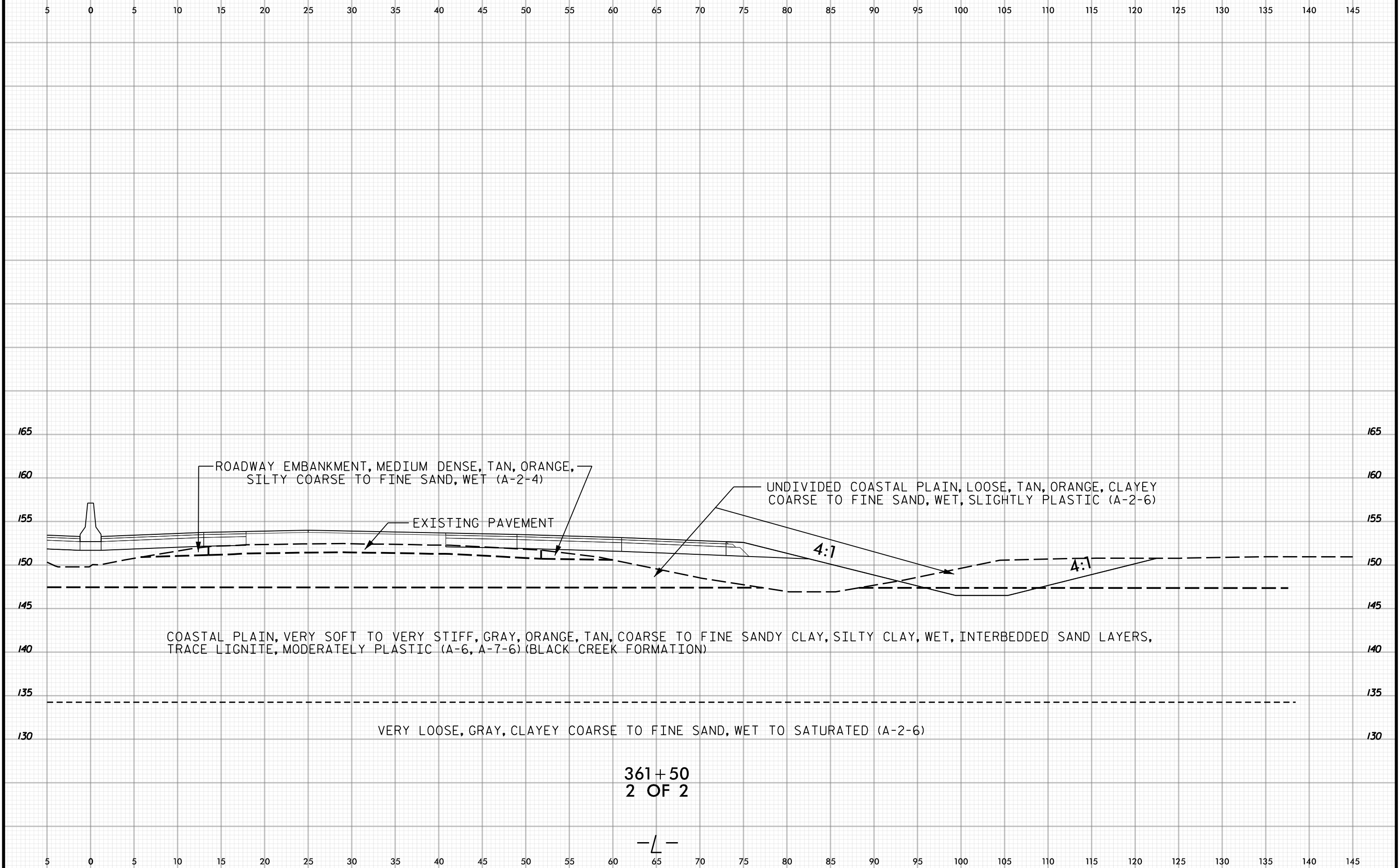



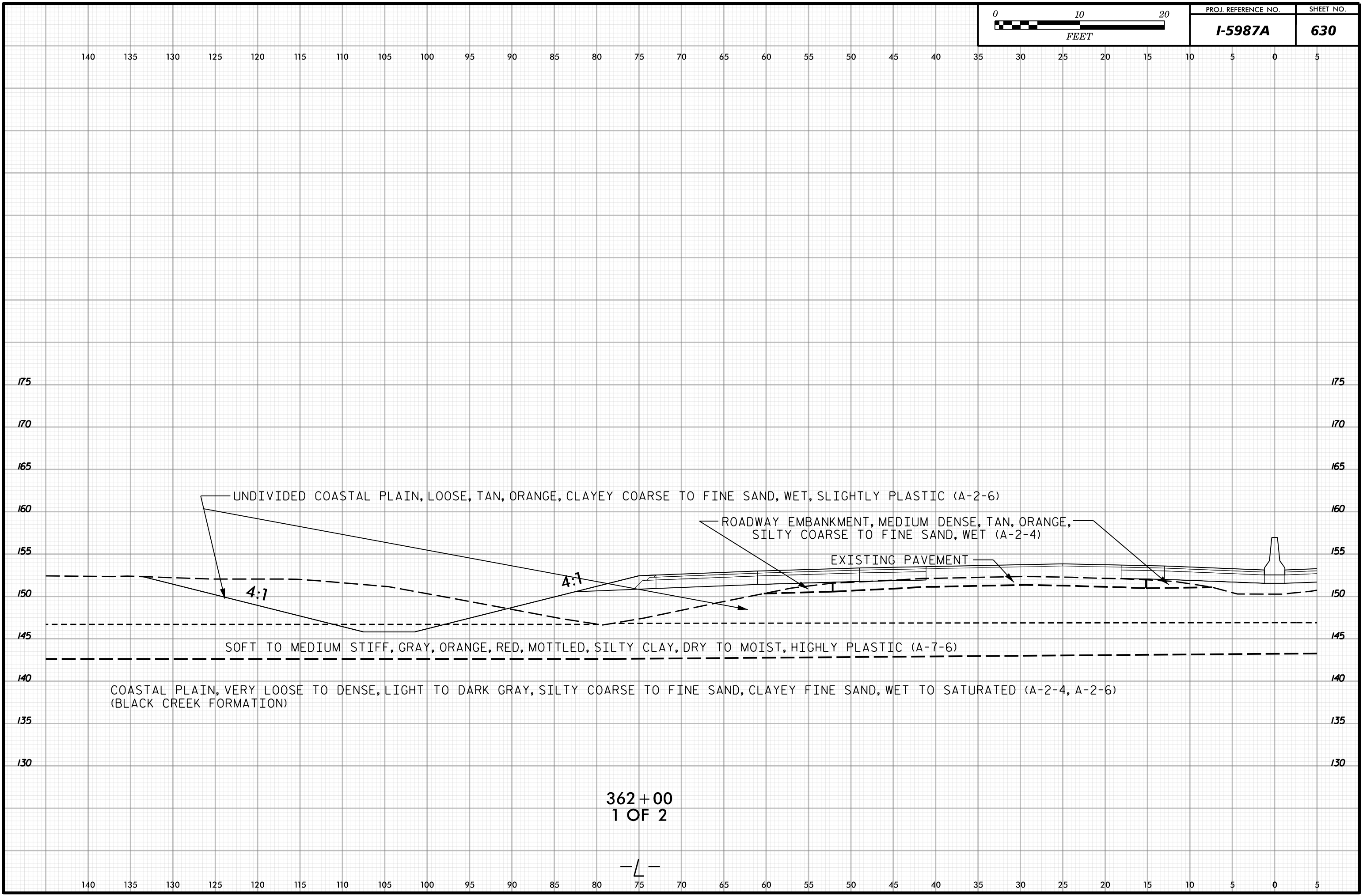

UNDIVIDED COASTAL PLAIN, LOOSE, TAN, ORANGE, CLAYEY COARSE TO FINE SAND, WET, SLIGHTLY PLASTIC (A-2-6)

ROADWAY EMBANKMENT, MEDIUM DENSE, TAN, ORANGE, SILTY COARSE TO FINE SAND, WET (A-2-4)

EXISTING PAVEMENT

SOFT TO MEDIUM STIFF, GRAY, ORANGE, RED, MOTTLED, SILTY CLAY, DRY TO MOIST, HIGHLY PLASTIC (A-7-6)

COASTAL PLAIN, VERY LOOSE TO DENSE, LIGHT TO DARK GRAY, SILTY COARSE TO FINE SAND, CLAYEY FINE SAND, WET TO SATURATED (A-2-4, A-2-6) (BLACK CREEK FORMATION)

362+00  
1 OF 2

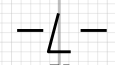

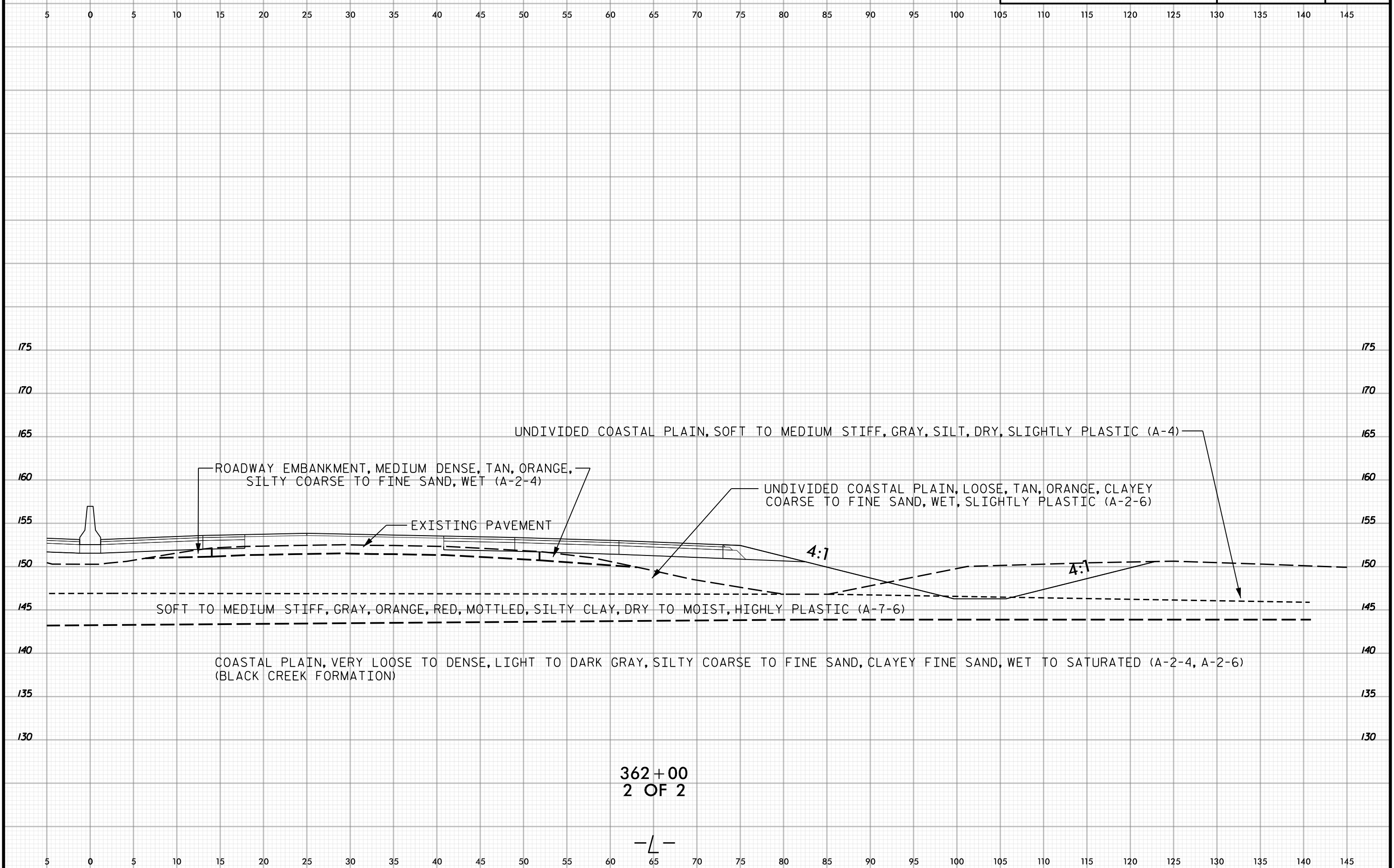

362+00  
2 OF 2

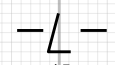

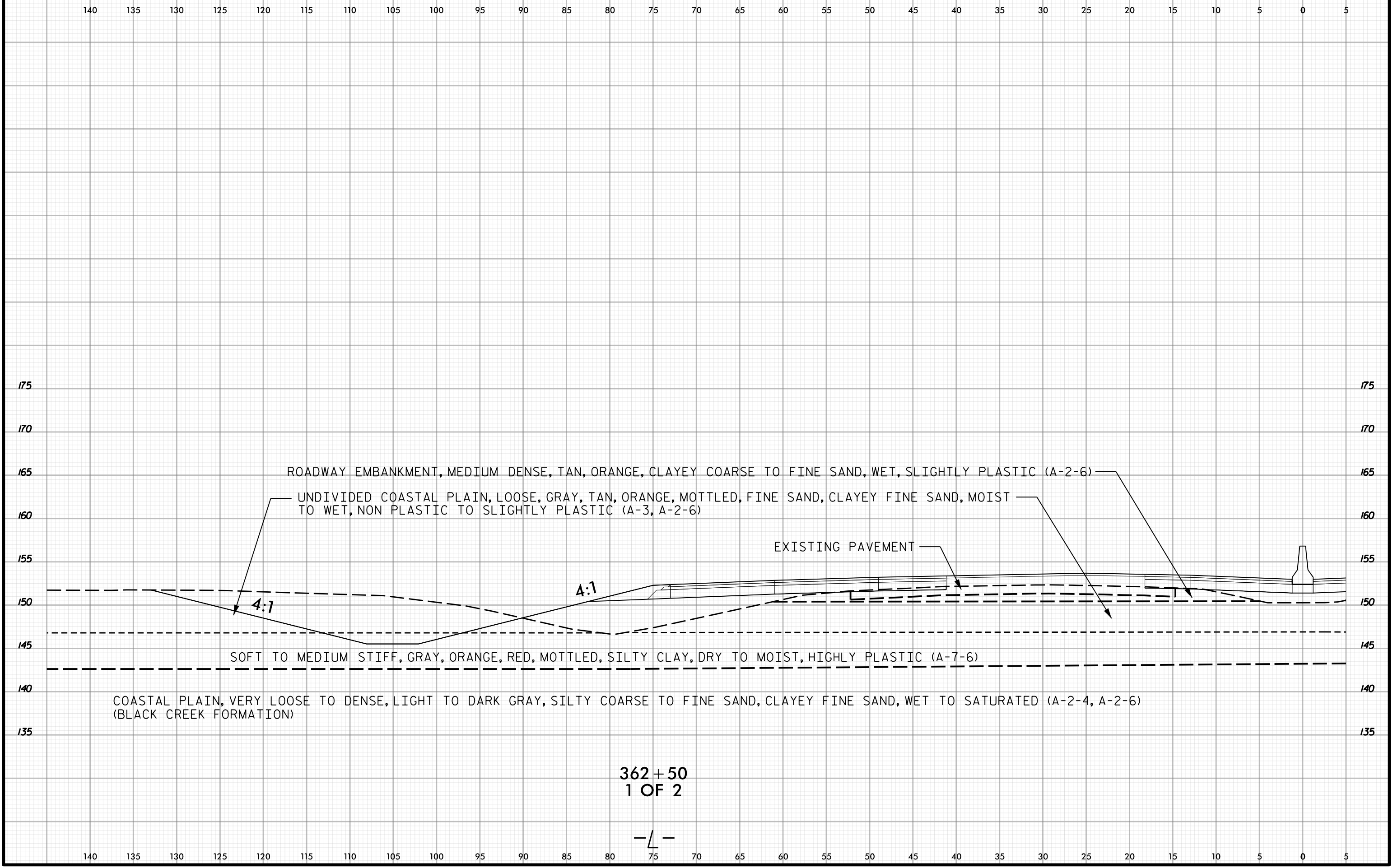

ROADWAY EMBANKMENT, MEDIUM DENSE, TAN, ORANGE, CLAYEY COARSE TO FINE SAND, WET, SLIGHTLY PLASTIC (A-2-6)

UNDIVIDED COASTAL PLAIN, LOOSE, GRAY, TAN, ORANGE, MOTTLED, FINE SAND, CLAYEY FINE SAND, MOIST TO WET, NON PLASTIC TO SLIGHTLY PLASTIC (A-3, A-2-6)

EXISTING PAVEMENT

SOFT TO MEDIUM STIFF, GRAY, ORANGE, RED, MOTTLED, SILTY CLAY, DRY TO MOIST, HIGHLY PLASTIC (A-7-6)

COASTAL PLAIN, VERY LOOSE TO DENSE, LIGHT TO DARK GRAY, SILTY COARSE TO FINE SAND, CLAYEY FINE SAND, WET TO SATURATED (A-2-4, A-2-6) (BLACK CREEK FORMATION)

4:1

4:1

362+50  
1 OF 2

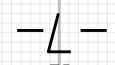



5 0 5 10 15 20 25 30 35 40 45 50 55 60 65 70 75 80 85 90 95 100 105 110 115 120 125 130 135 140 145

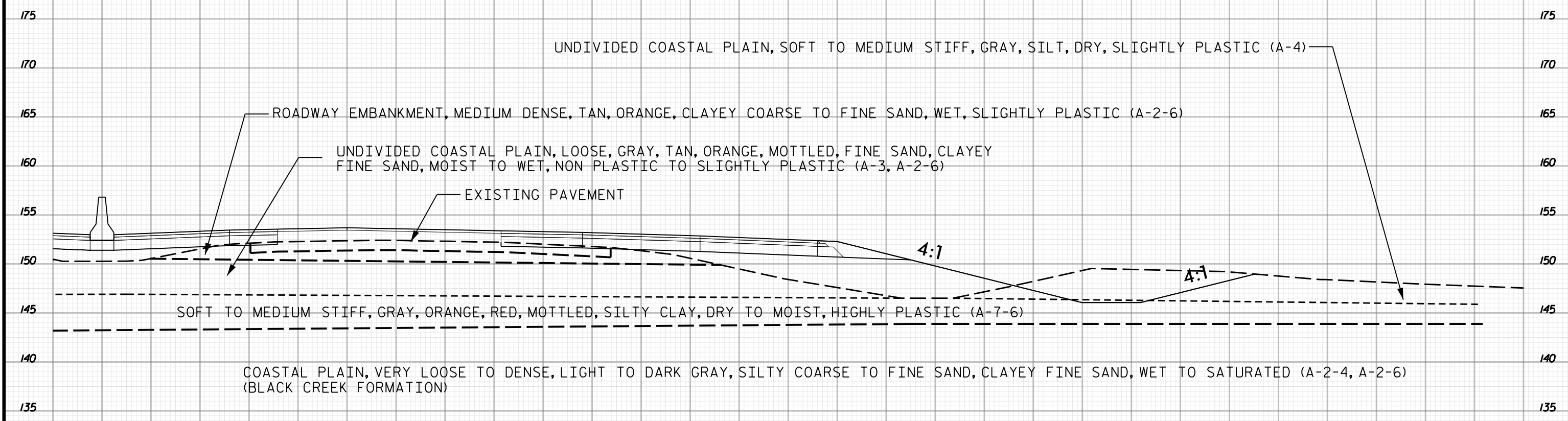

362+50  
2 OF 2

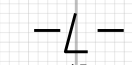

5 0 5 10 15 20 25 30 35 40 45 50 55 60 65 70 75 80 85 90 95 100 105 110 115 120 125 130 135 140 145

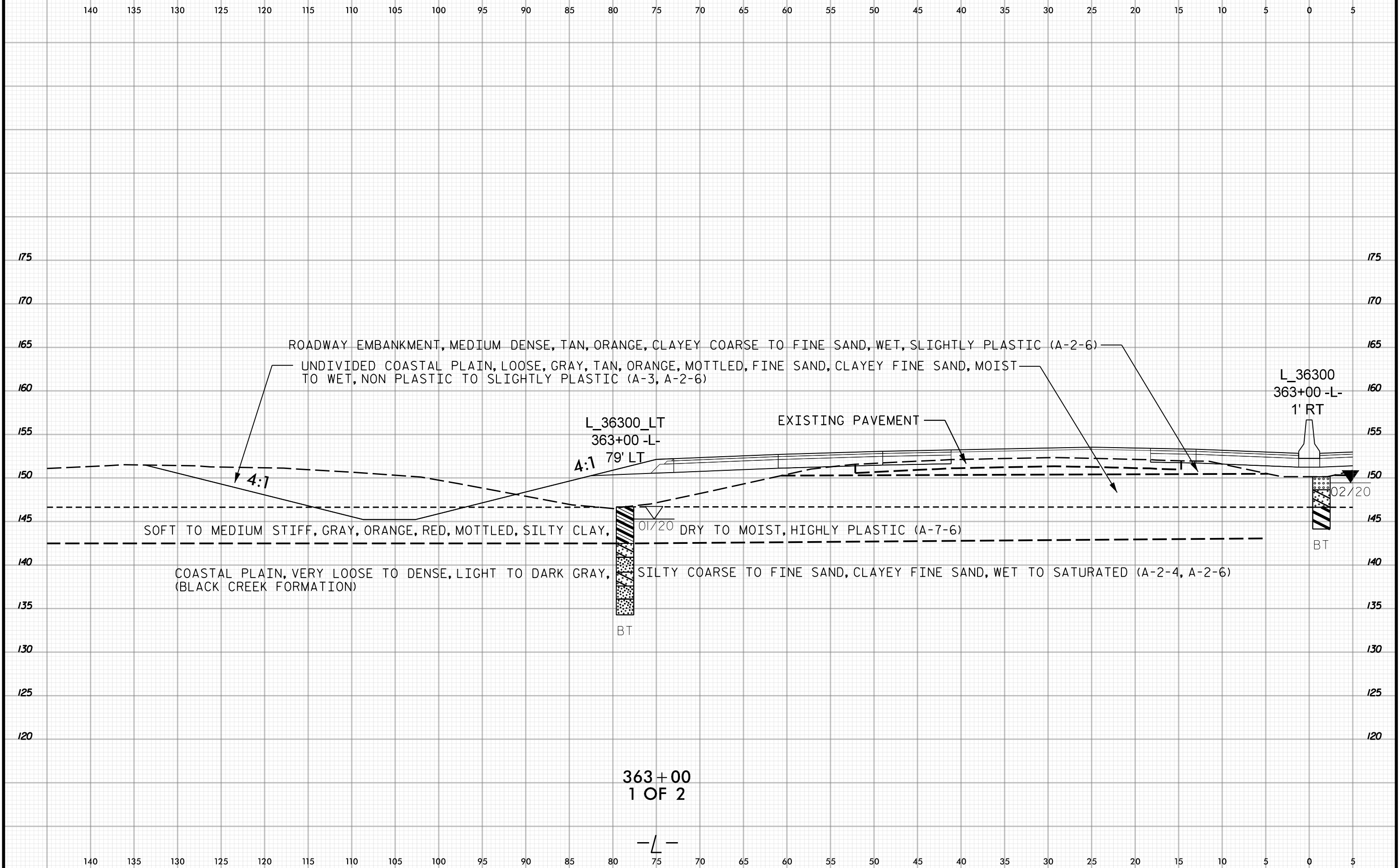

363+00  
1 OF 2

-L-

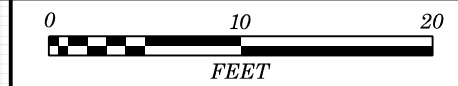

5 0 5 10 15 20 25 30 35 40 45 50 55 60 65 70 75 80 85 90 95 100 105 110 115 120 125 130 135 140 145

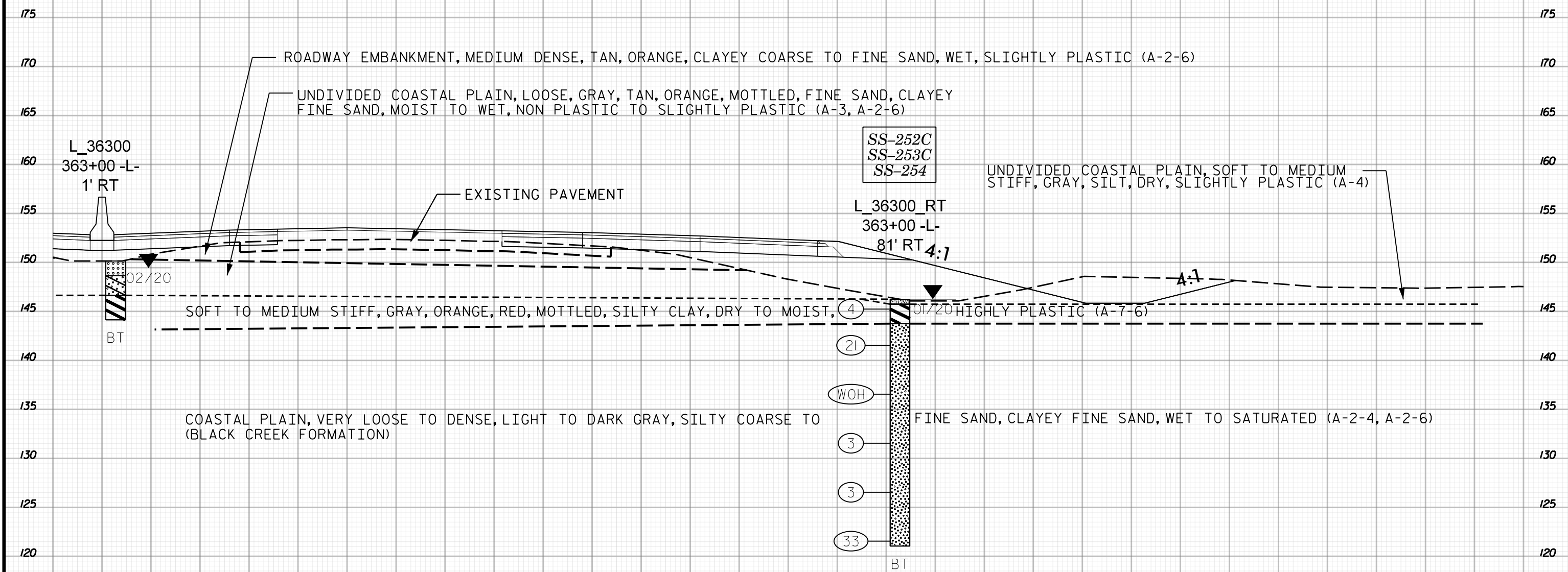

363+00  
2 OF 2

-L-

5 0 5 10 15 20 25 30 35 40 45 50 55 60 65 70 75 80 85 90 95 100 105 110 115 120 125 130 135 140 145



140 135 130 125 120 115 110 105 100 95 90 85 80 75 70 65 60 55 50 45 40 35 30 25 20 15 10 5 0 5

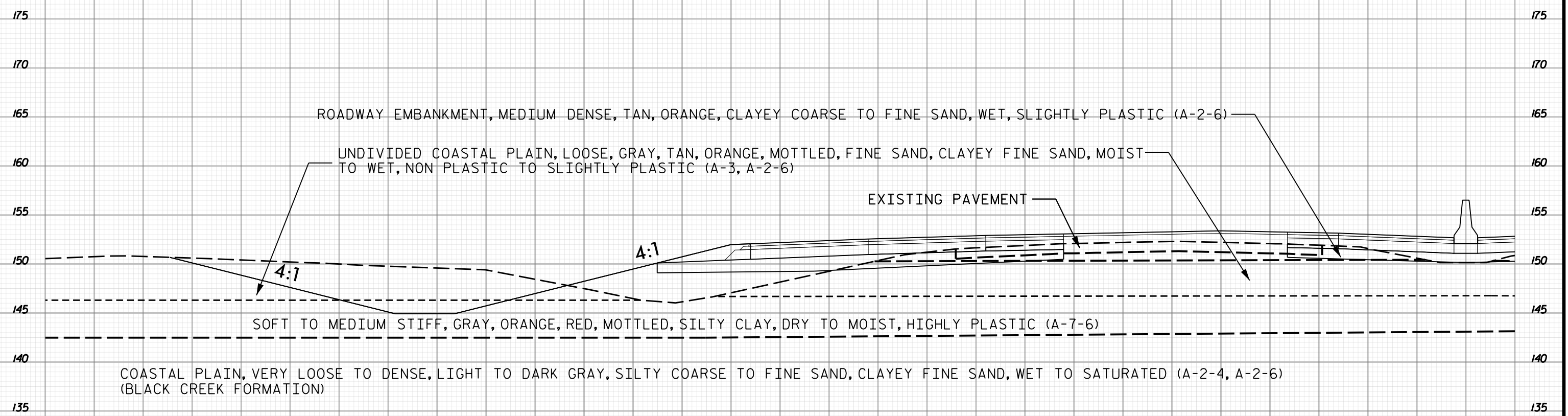

363 + 50  
1 OF 2

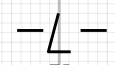

140 135 130 125 120 115 110 105 100 95 90 85 80 75 70 65 60 55 50 45 40 35 30 25 20 15 10 5 0 5



5 0 5 10 15 20 25 30 35 40 45 50 55 60 65 70 75 80 85 90 95 100 105 110 115 120 125 130 135 140 145

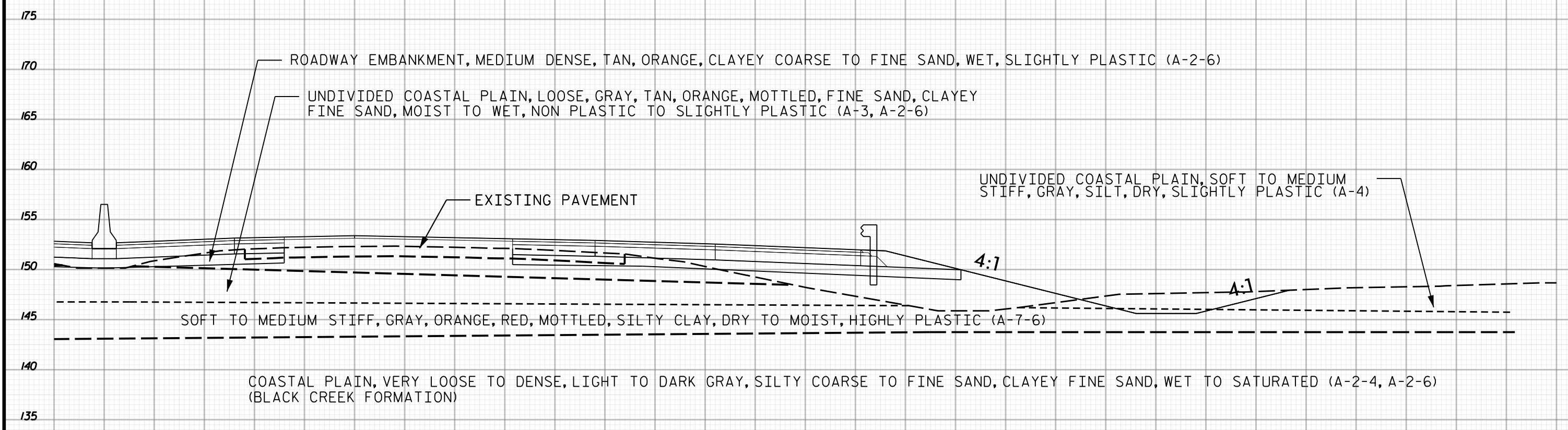

363+50  
2 OF 2

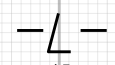

5 0 5 10 15 20 25 30 35 40 45 50 55 60 65 70 75 80 85 90 95 100 105 110 115 120 125 130 135 140 145



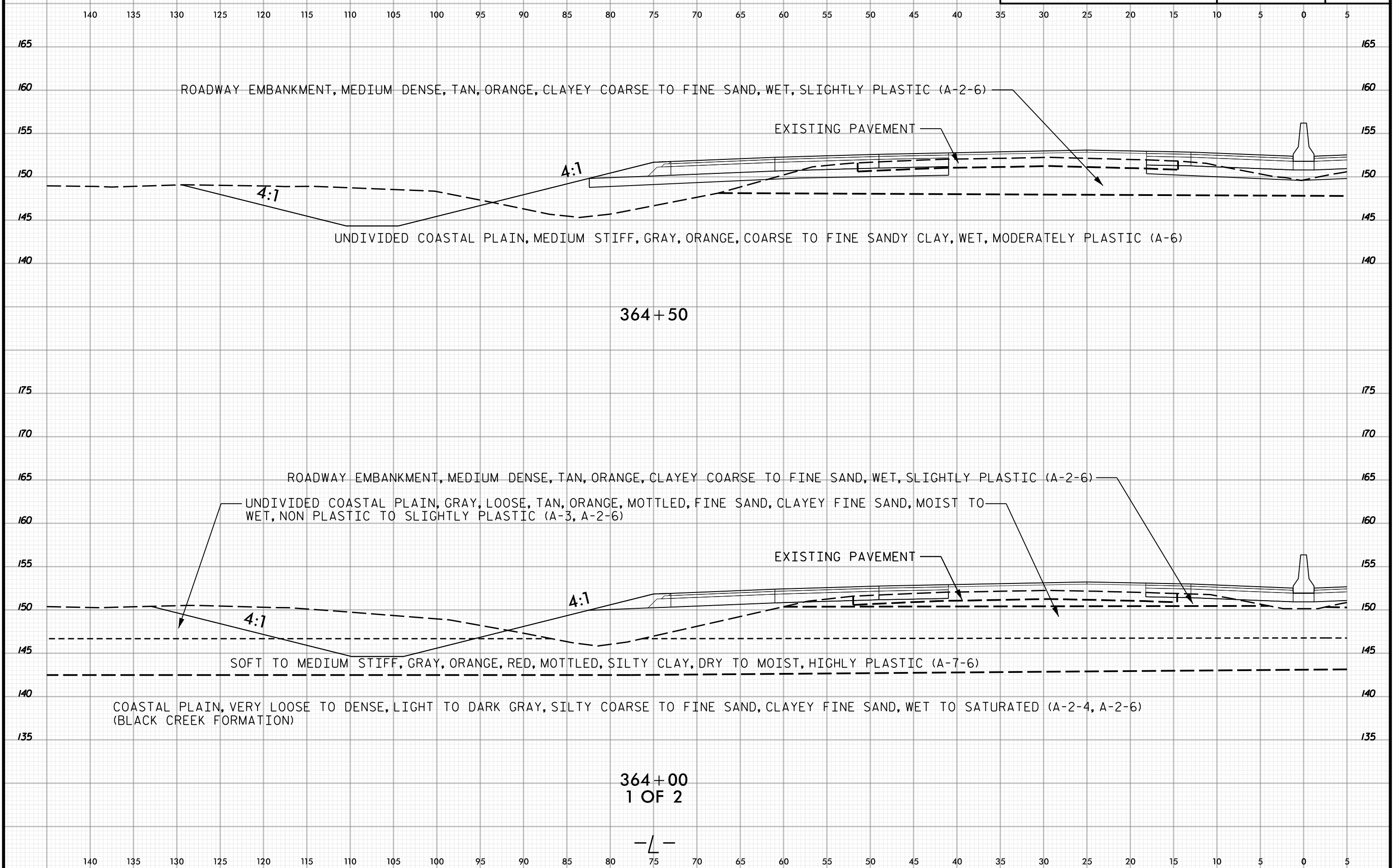

364+00  
1 OF 2

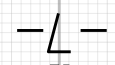

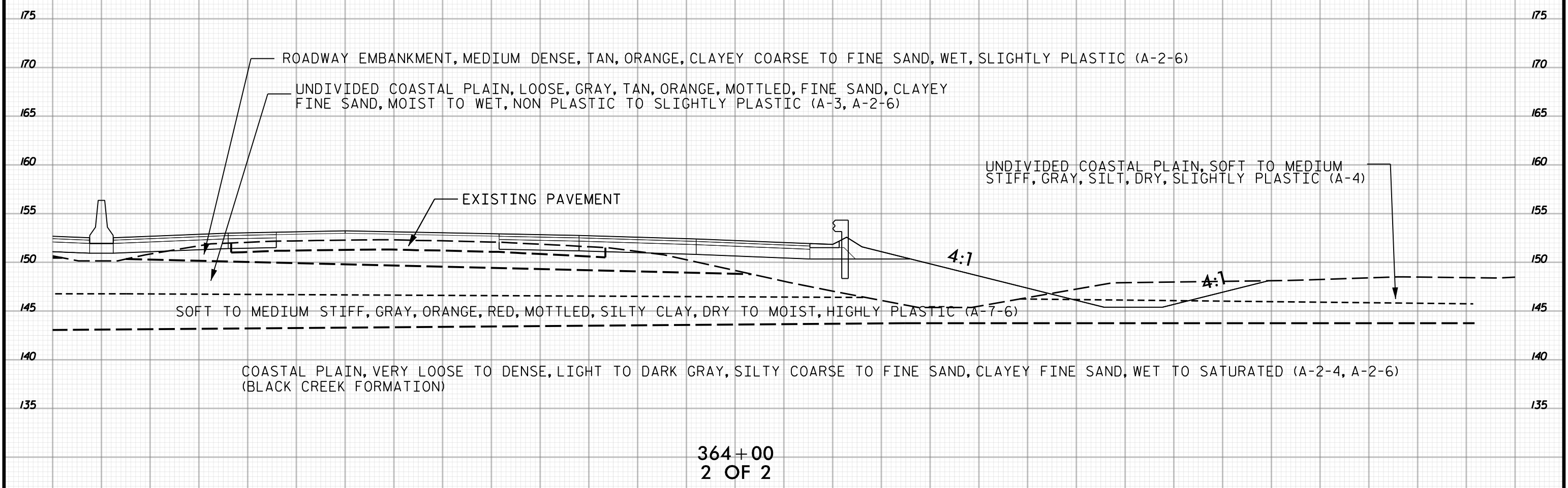
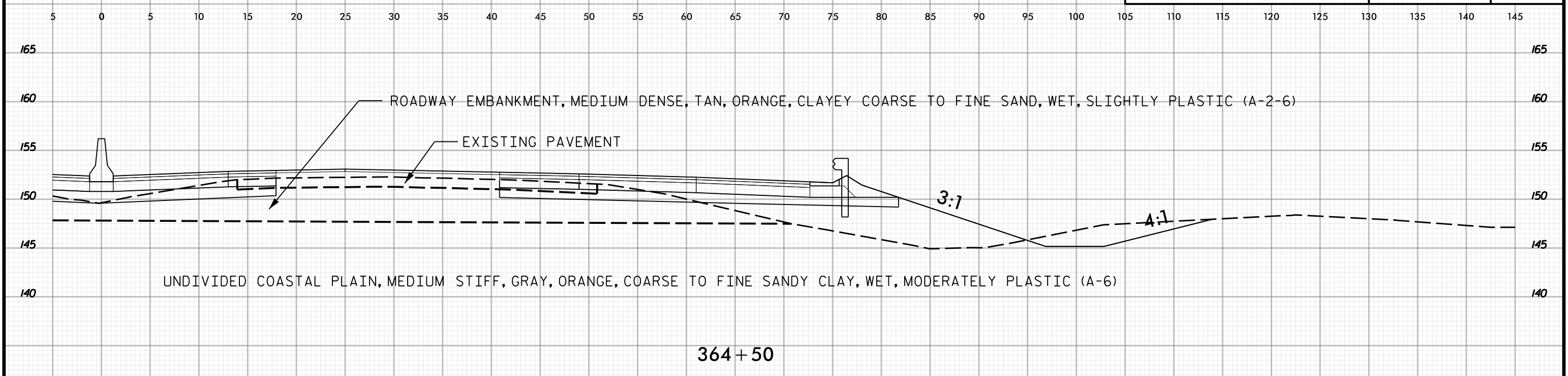



140 135 130 125 120 115 110 105 100 95 90 85 80 75 70 65 60 55 50 45 40 35 30 25 20 15 10 5 0 5

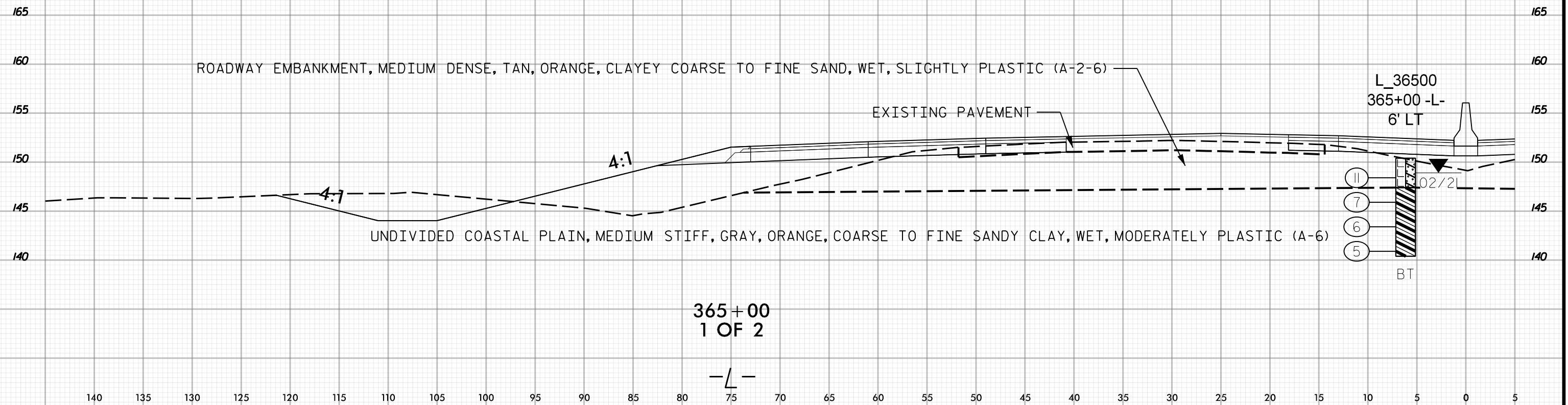

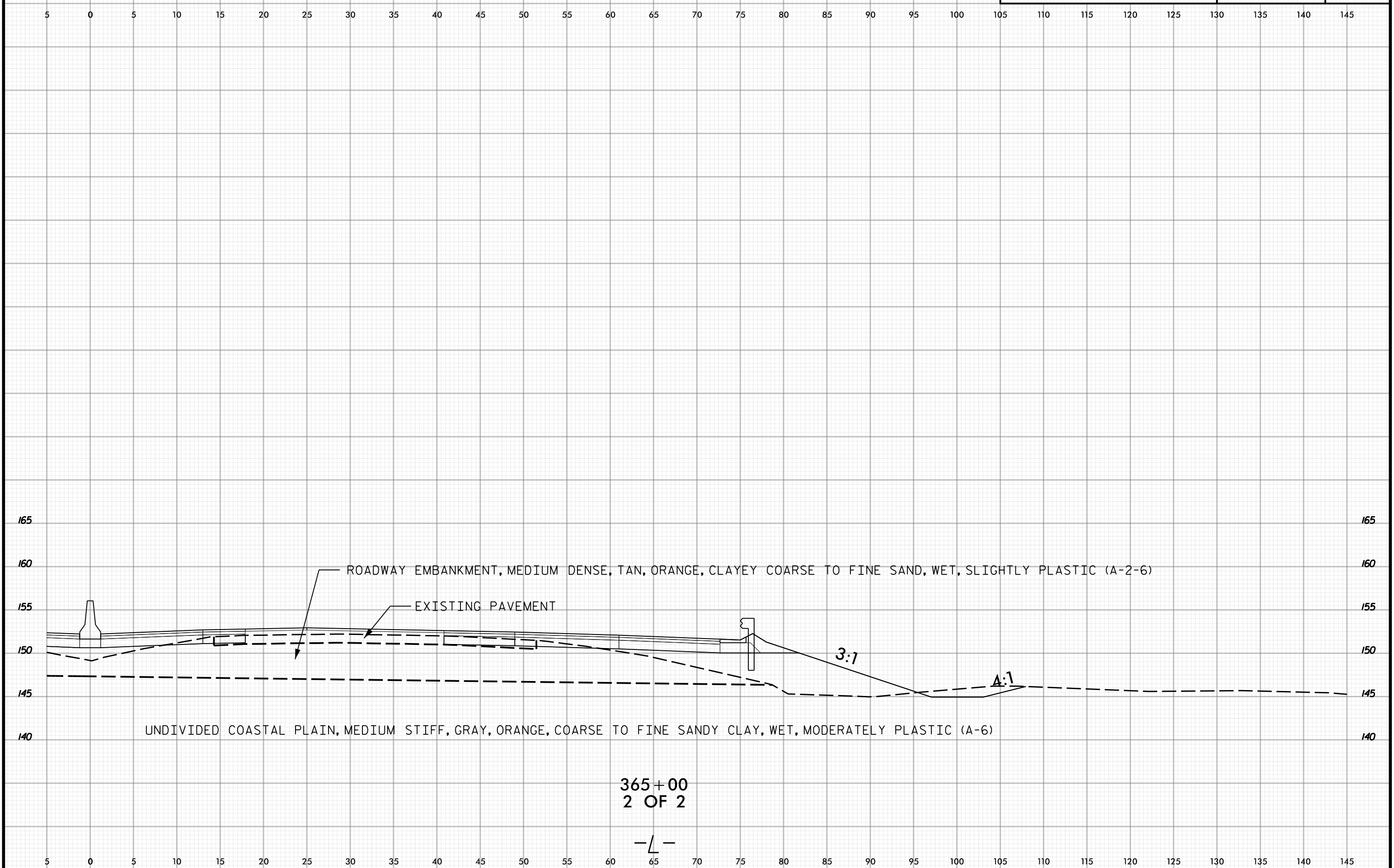

ROADWAY EMBANKMENT, MEDIUM DENSE, TAN, ORANGE, CLAYEY COARSE TO FINE SAND, WET, SLIGHTLY PLASTIC (A-2-6)

EXISTING PAVEMENT

UNDIVIDED COASTAL PLAIN, MEDIUM STIFF, GRAY, ORANGE, COARSE TO FINE SANDY CLAY, WET, MODERATELY PLASTIC (A-6)

365+00  
2 OF 2

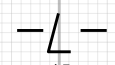

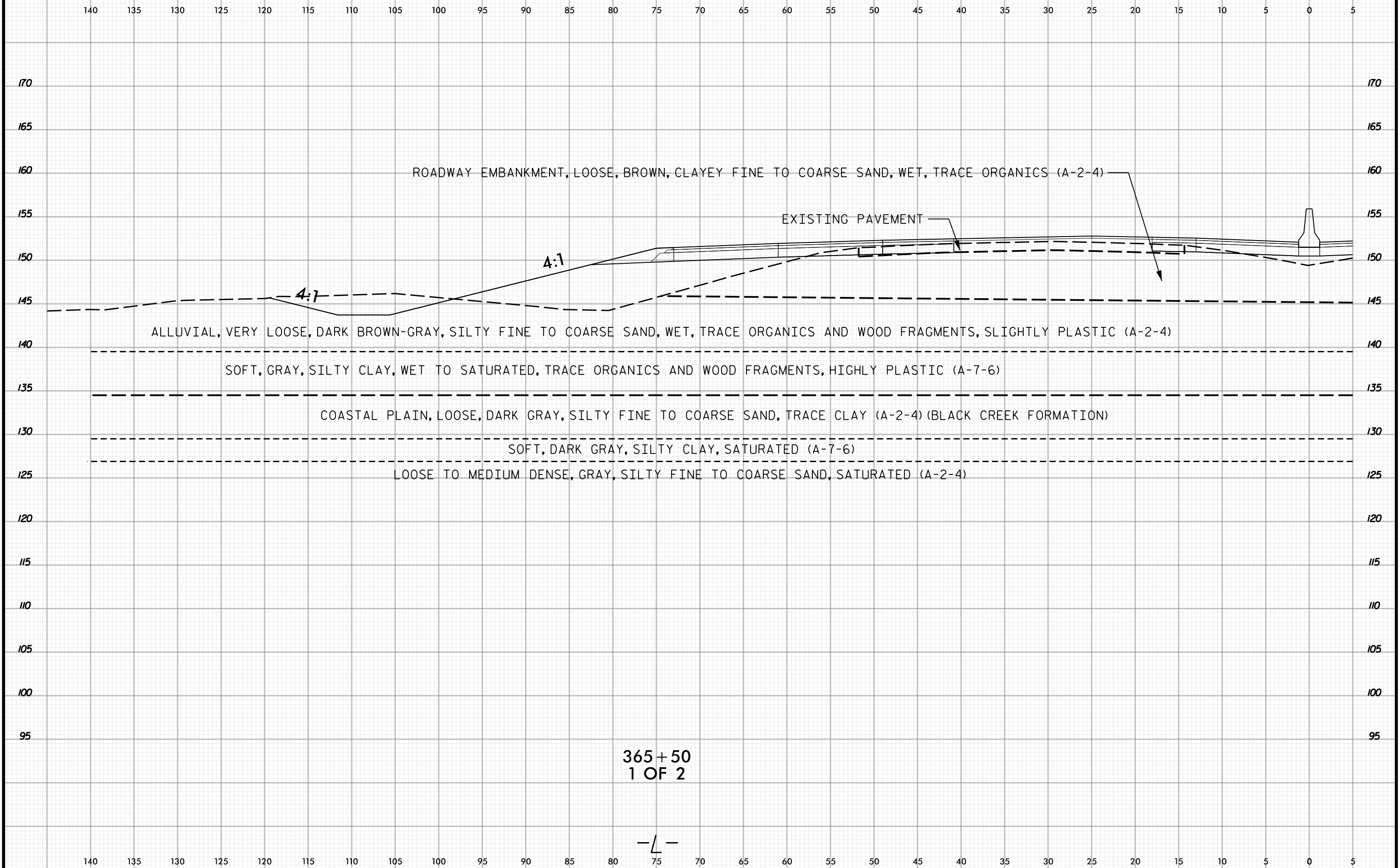

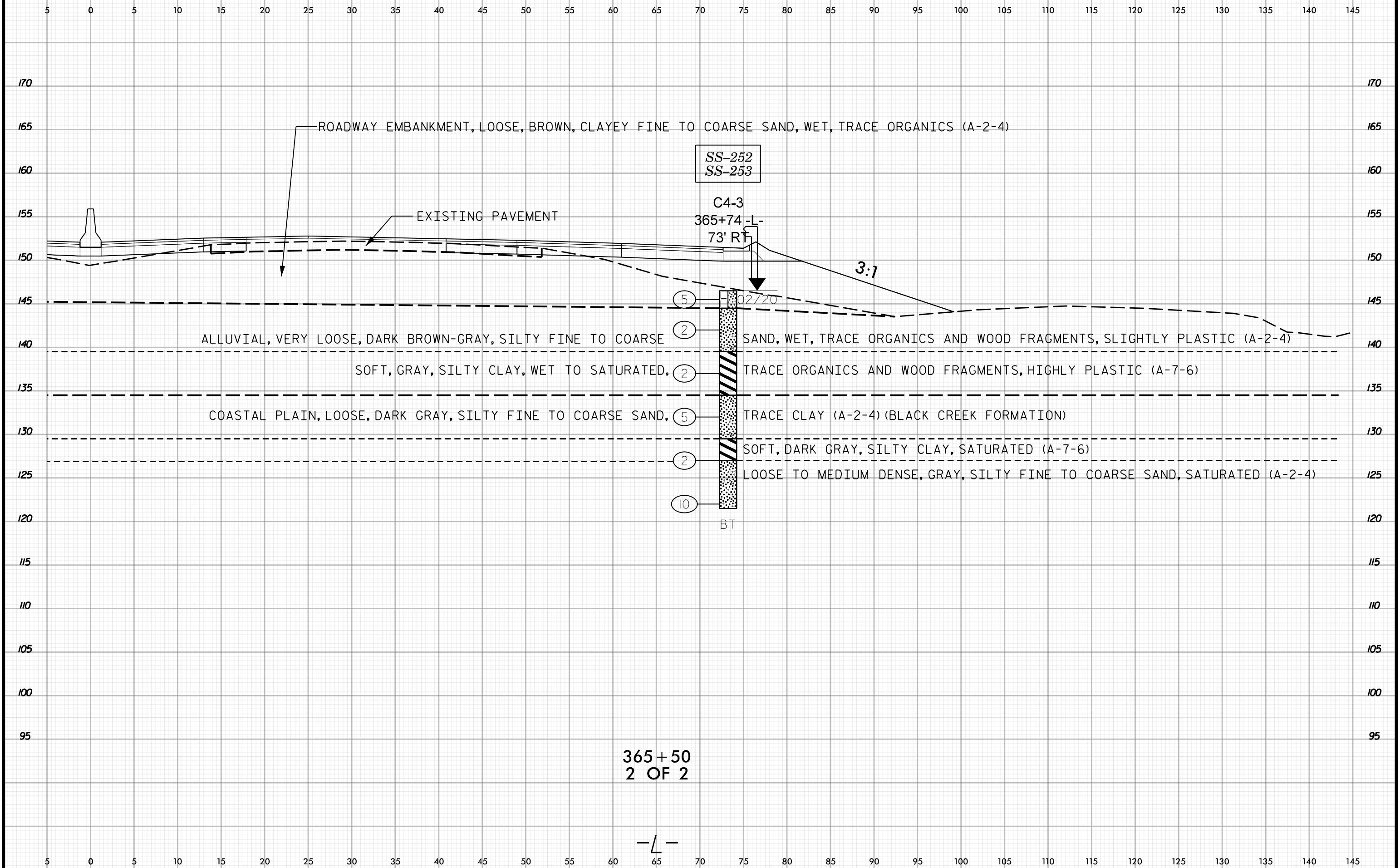
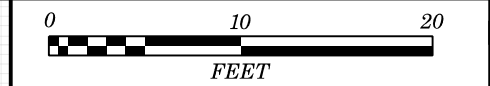

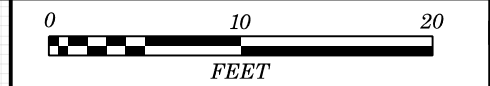

140 135 130 125 120 115 110 105 100 95 90 85 80 75 70 65 60 55 50 45 40 35 30 25 20 15 10 5 0 5

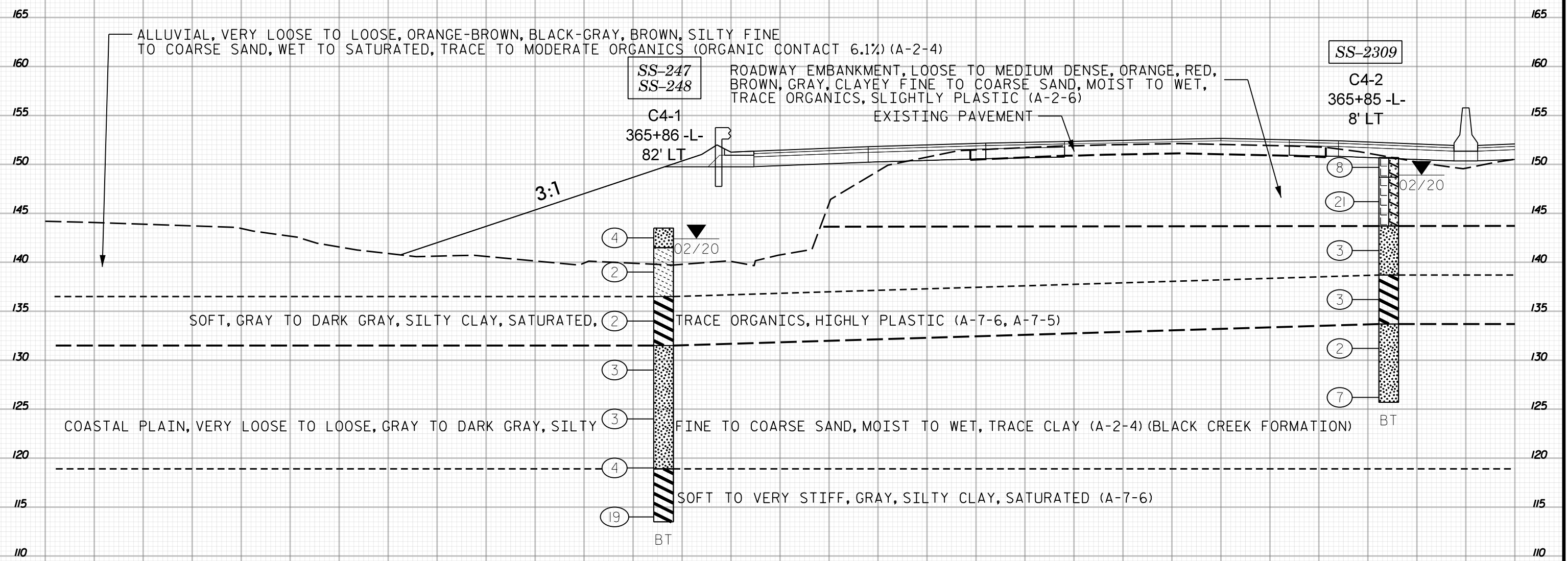

366+00  
1 OF 2

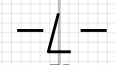

140 135 130 125 120 115 110 105 100 95 90 85 80 75 70 65 60 55 50 45 40 35 30 25 20 15 10 5 0 5



5 0 5 10 15 20 25 30 35 40 45 50 55 60 65 70 75 80 85 90 95 100 105 110 115 120 125 130 135 140 145

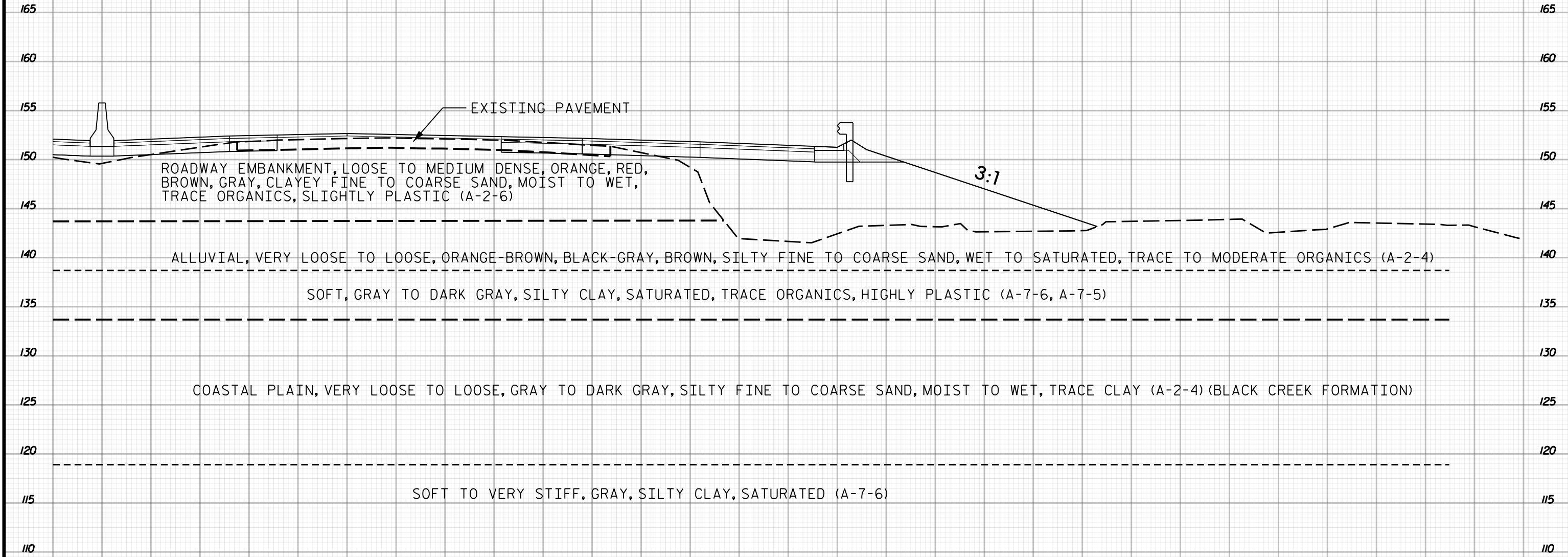

366+00  
2 OF 2

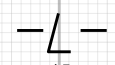

5 0 5 10 15 20 25 30 35 40 45 50 55 60 65 70 75 80 85 90 95 100 105 110 115 120 125 130 135 140 145



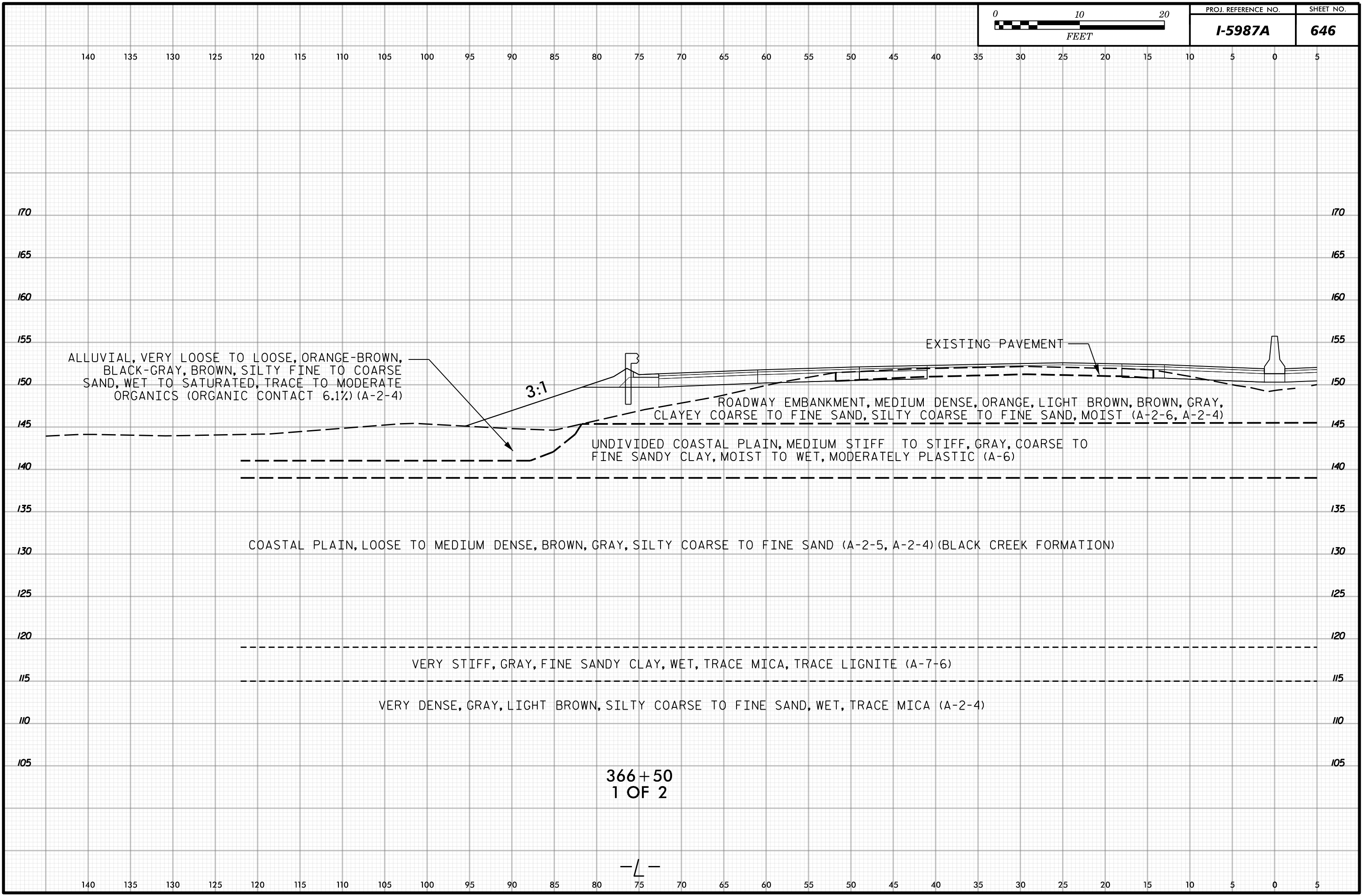

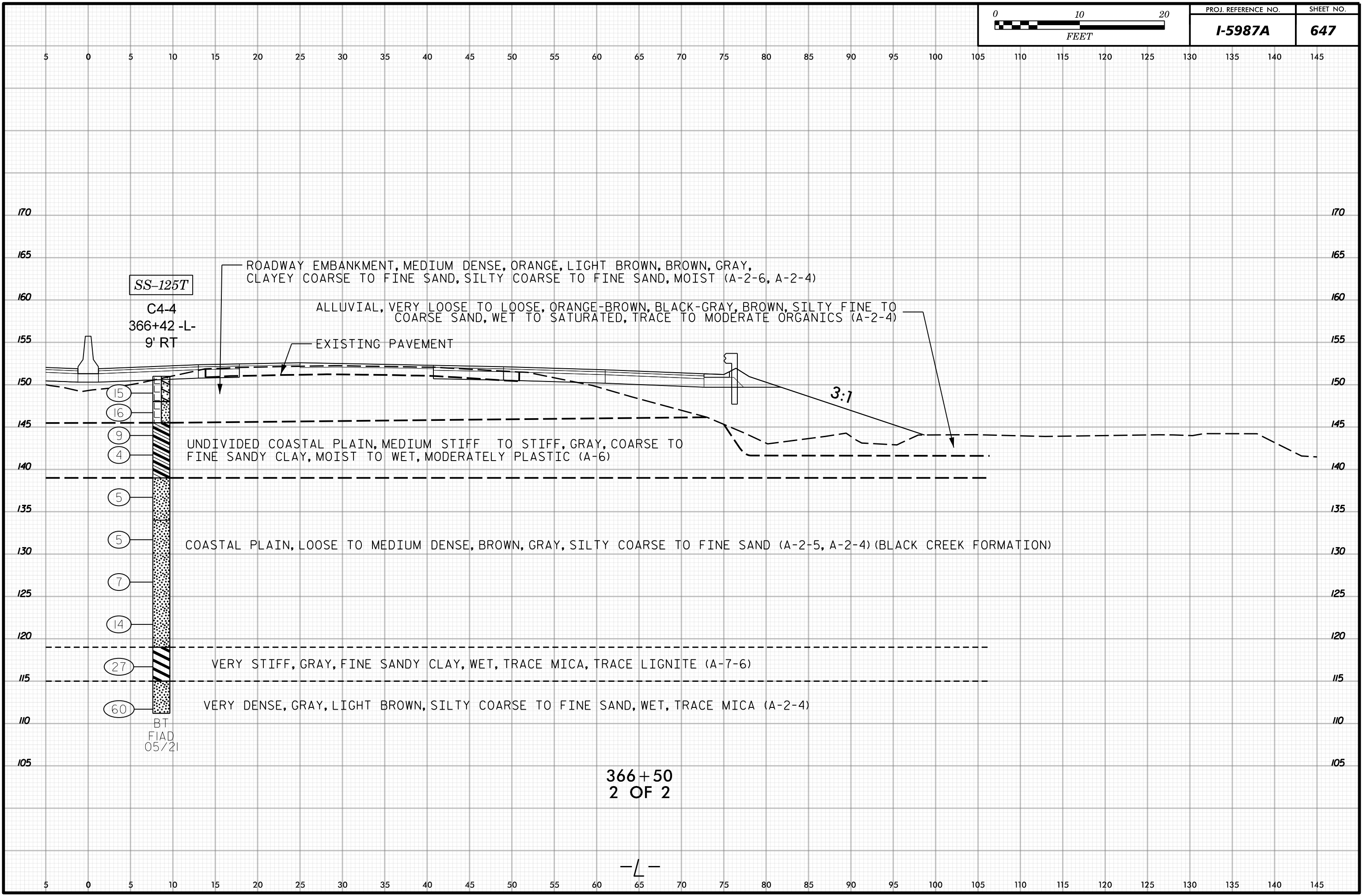

SS-125T

C4-4  
366+42 -L-  
9' RT

ROADWAY EMBANKMENT, MEDIUM DENSE, ORANGE, LIGHT BROWN, BROWN, GRAY,  
CLAYEY COARSE TO FINE SAND, SILTY COARSE TO FINE SAND, MOIST (A-2-6, A-2-4)

ALLUVIAL, VERY LOOSE TO LOOSE, ORANGE-BROWN, BLACK-GRAY, BROWN, SILTY FINE TO  
COARSE SAND, WET TO SATURATED, TRACE TO MODERATE ORGANICS (A-2-4)

EXISTING PAVEMENT

3:1

UNDIVIDED COASTAL PLAIN, MEDIUM STIFF TO STIFF, GRAY, COARSE TO  
FINE SANDY CLAY, MOIST TO WET, MODERATELY PLASTIC (A-6)

COASTAL PLAIN, LOOSE TO MEDIUM DENSE, BROWN, GRAY, SILTY COARSE TO FINE SAND (A-2-5, A-2-4) (BLACK CREEK FORMATION)

VERY STIFF, GRAY, FINE SANDY CLAY, WET, TRACE MICA, TRACE LIGNITE (A-7-6)

VERY DENSE, GRAY, LIGHT BROWN, SILTY COARSE TO FINE SAND, WET, TRACE MICA (A-2-4)

BT  
FIAD  
05/21

366+50  
2 OF 2

-L-

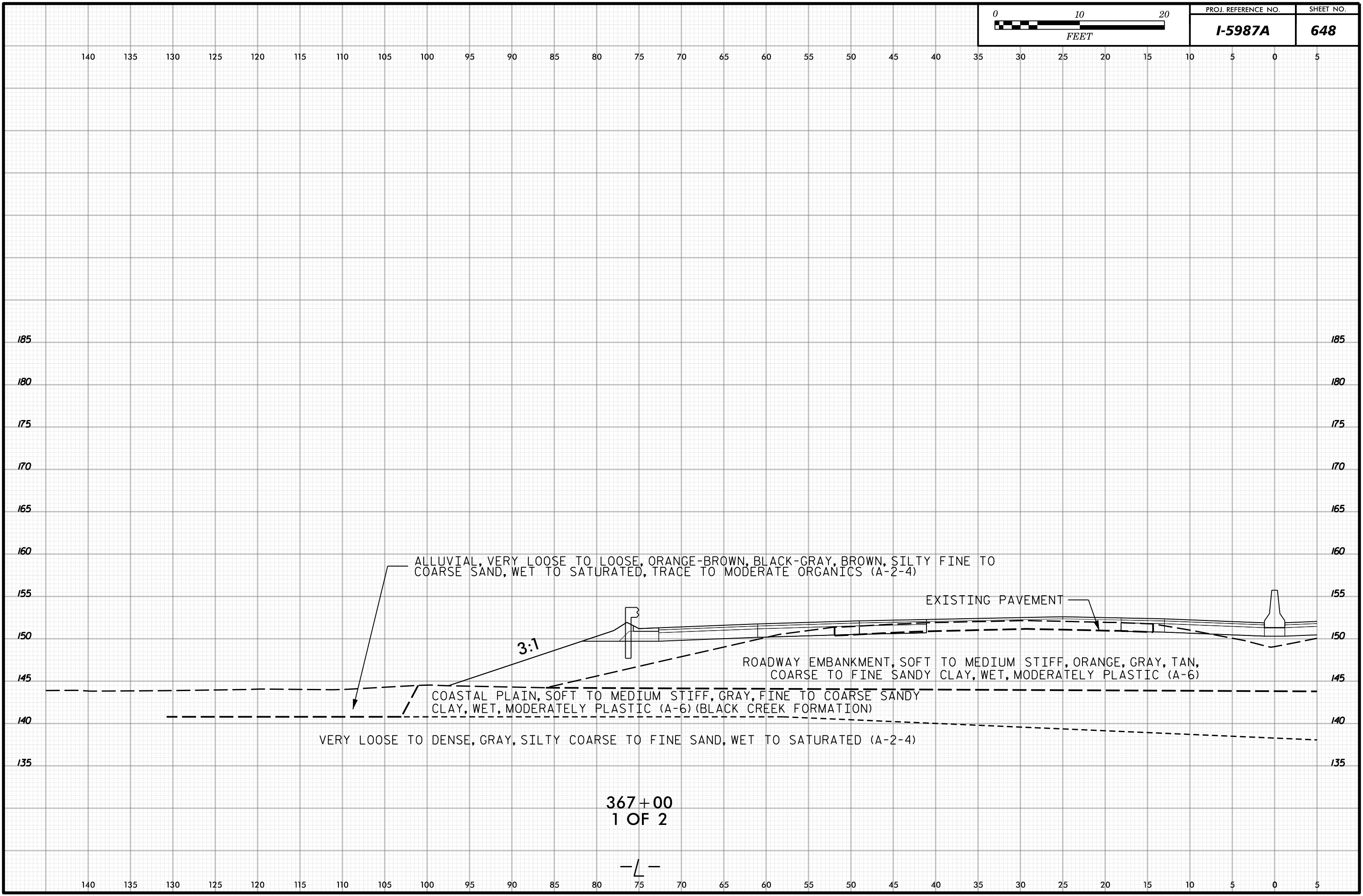

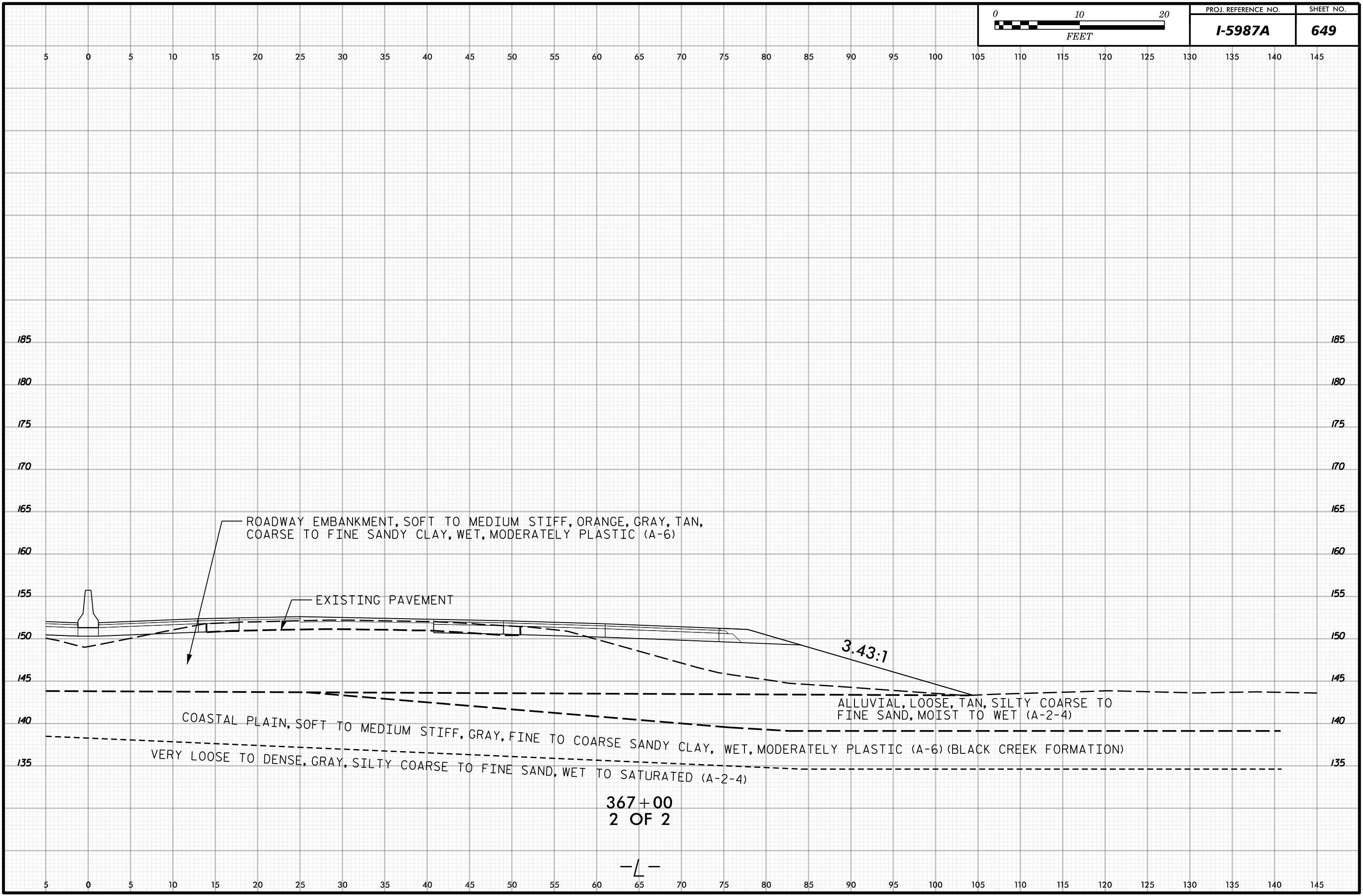

367+00  
2 OF 2

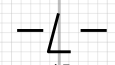

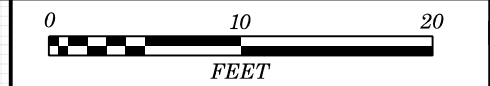

140 135 130 125 120 115 110 105 100 95 90 85 80 75 70 65 60 55 50 45 40 35 30 25 20 15 10 5 0 5

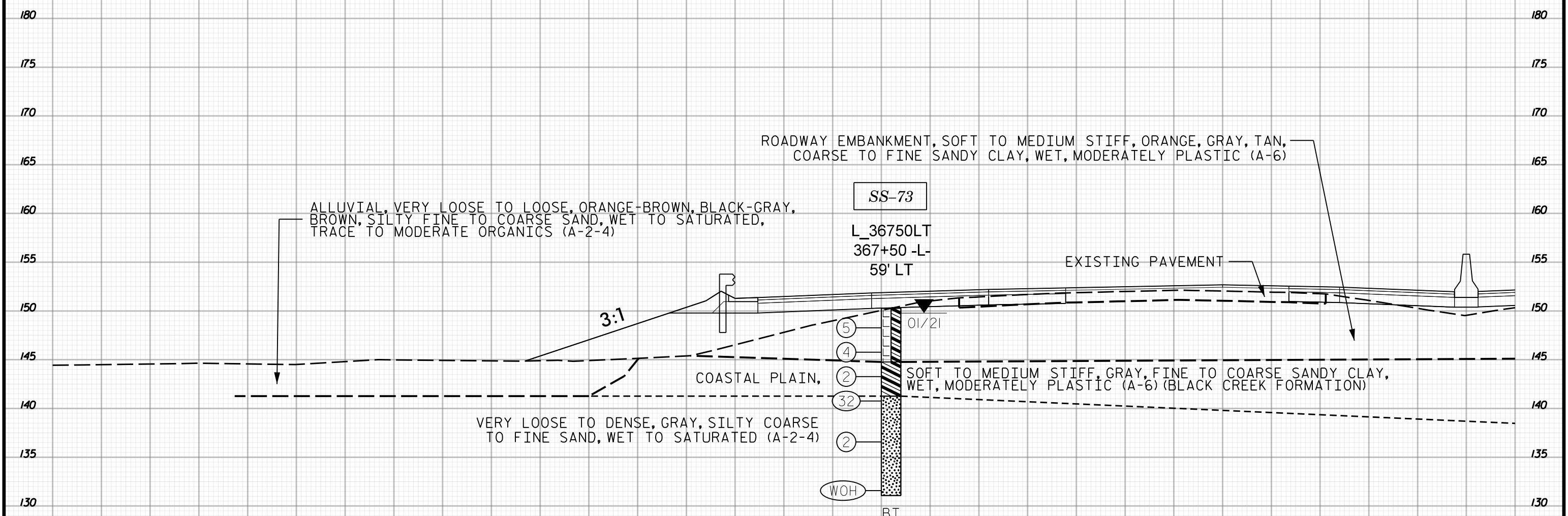

367+50  
1 OF 2

140 135 130 125 120 115 110 105 100 95 90 85 80 75 70 65 60 55 50 45 40 35 30 25 20 15 10 5 0 5



5 0 5 10 15 20 25 30 35 40 45 50 55 60 65 70 75 80 85 90 95 100 105 110 115 120 125 130 135 140 145

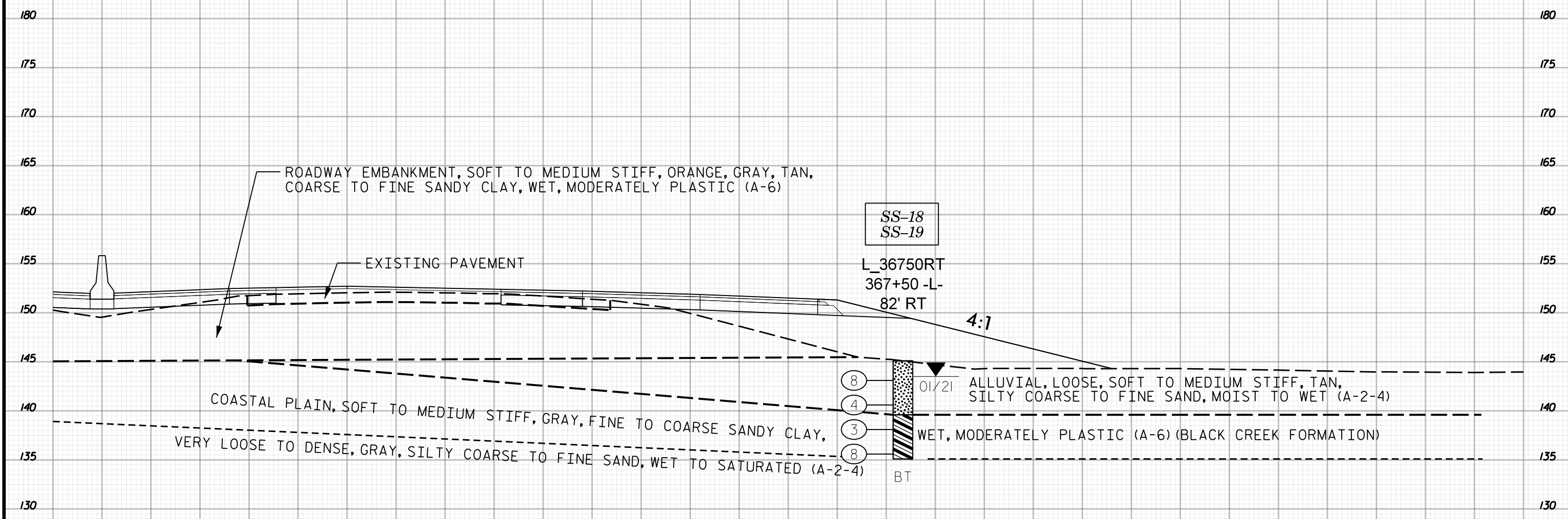

ROADWAY EMBANKMENT, SOFT TO MEDIUM STIFF, ORANGE, GRAY, TAN, COARSE TO FINE SANDY CLAY, WET, MODERATELY PLASTIC (A-6)

EXISTING PAVEMENT

SS-18  
SS-19

L\_36750RT  
367+50 -L-  
82' RT

4:1

COASTAL PLAIN, SOFT TO MEDIUM STIFF, GRAY, FINE TO COARSE SANDY CLAY,  
VERY LOOSE TO DENSE, GRAY, SILTY COARSE TO FINE SAND, WET TO SATURATED (A-2-4)

- 8
- 4
- 3
- 8

BT

01/21 ALLUVIAL, LOOSE, SOFT TO MEDIUM STIFF, TAN, SILTY COARSE TO FINE SAND, MOIST TO WET (A-2-4)

WET, MODERATELY PLASTIC (A-6) (BLACK CREEK FORMATION)

367+50  
2 OF 2

-L-

5 0 5 10 15 20 25 30 35 40 45 50 55 60 65 70 75 80 85 90 95 100 105 110 115 120 125 130 135 140 145



140 135 130 125 120 115 110 105 100 95 90 85 80 75 70 65 60 55 50 45 40 35 30 25 20 15 10 5 0 5

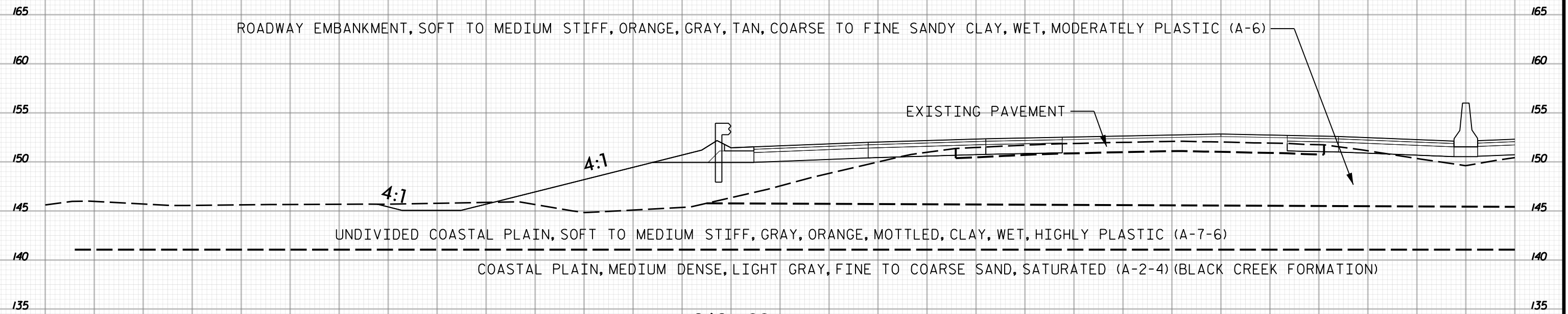

368+00  
1 OF 2

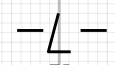

140 135 130 125 120 115 110 105 100 95 90 85 80 75 70 65 60 55 50 45 40 35 30 25 20 15 10 5 0 5

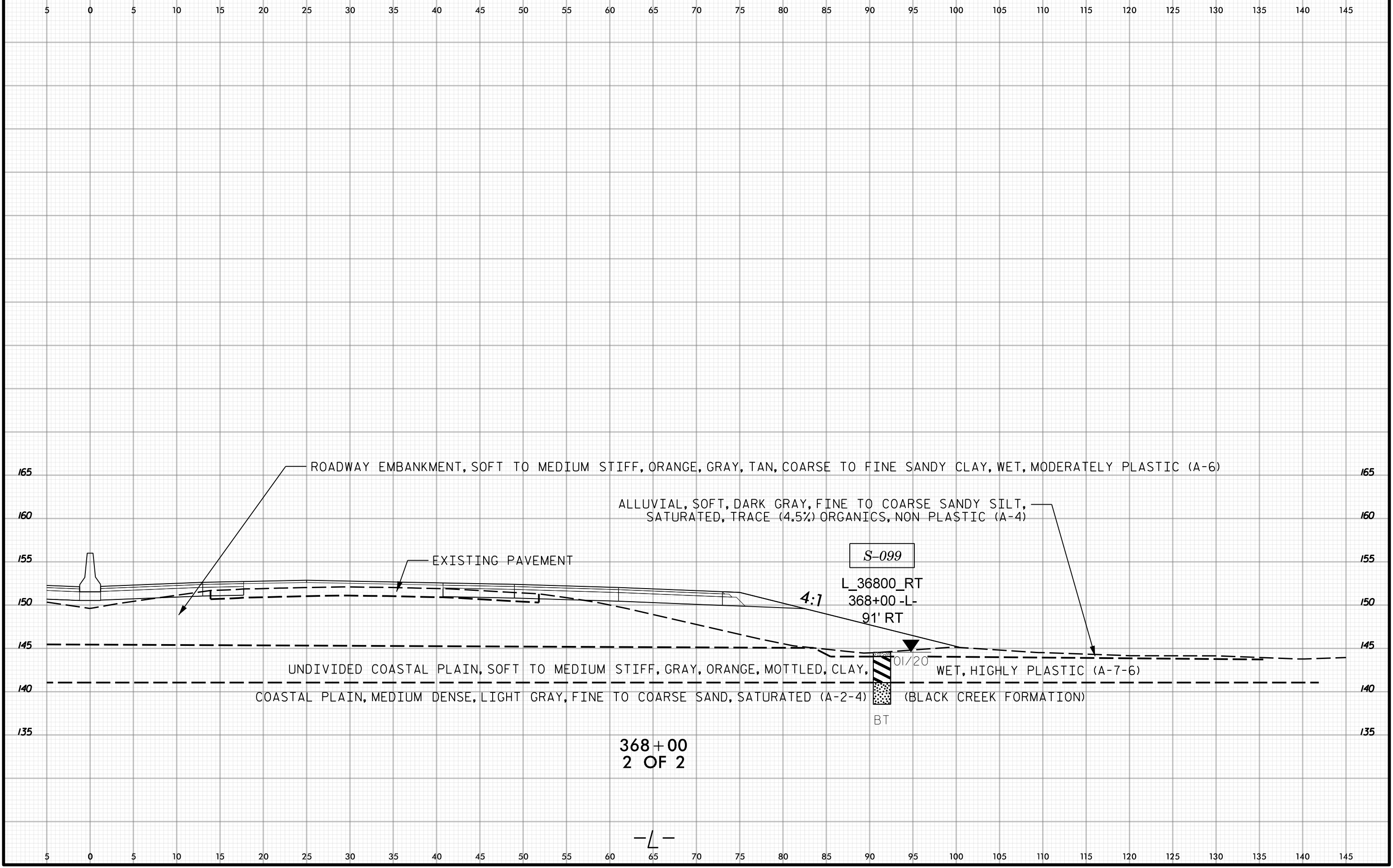
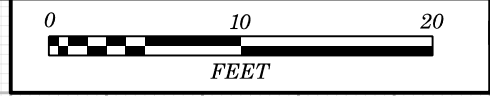

368+00  
2 OF 2

—L—



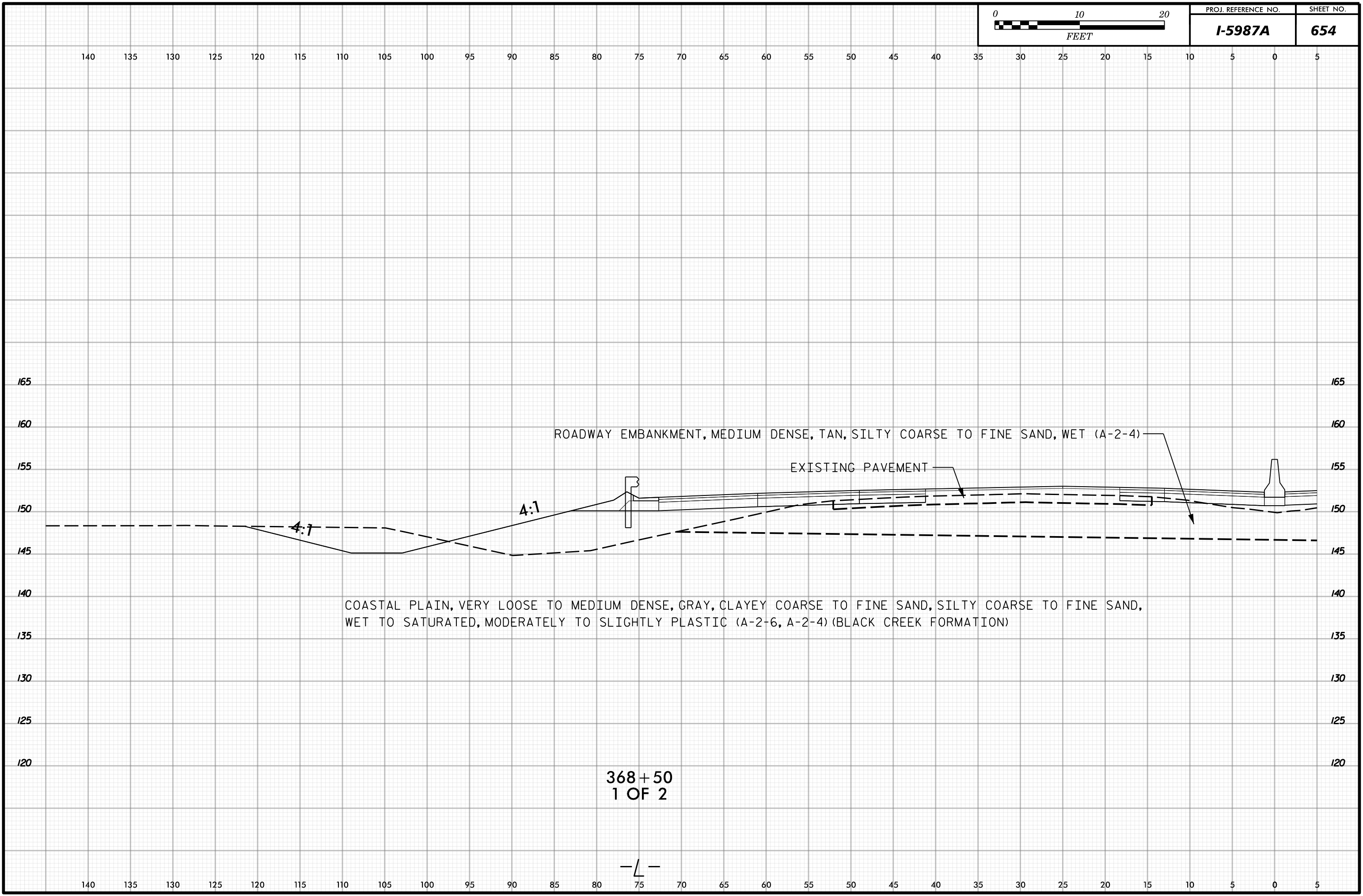

ROADWAY EMBANKMENT, MEDIUM DENSE, TAN, SILTY COARSE TO FINE SAND, WET (A-2-4)

EXISTING PAVEMENT

COASTAL PLAIN, VERY LOOSE TO MEDIUM DENSE, GRAY, CLAYEY COARSE TO FINE SAND, SILTY COARSE TO FINE SAND, WET TO SATURATED, MODERATELY TO SLIGHTLY PLASTIC (A-2-6, A-2-4) (BLACK CREEK FORMATION)

368+50  
1 OF 2

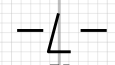



5 0 5 10 15 20 25 30 35 40 45 50 55 60 65 70 75 80 85 90 95 100 105 110 115 120 125 130 135 140 145

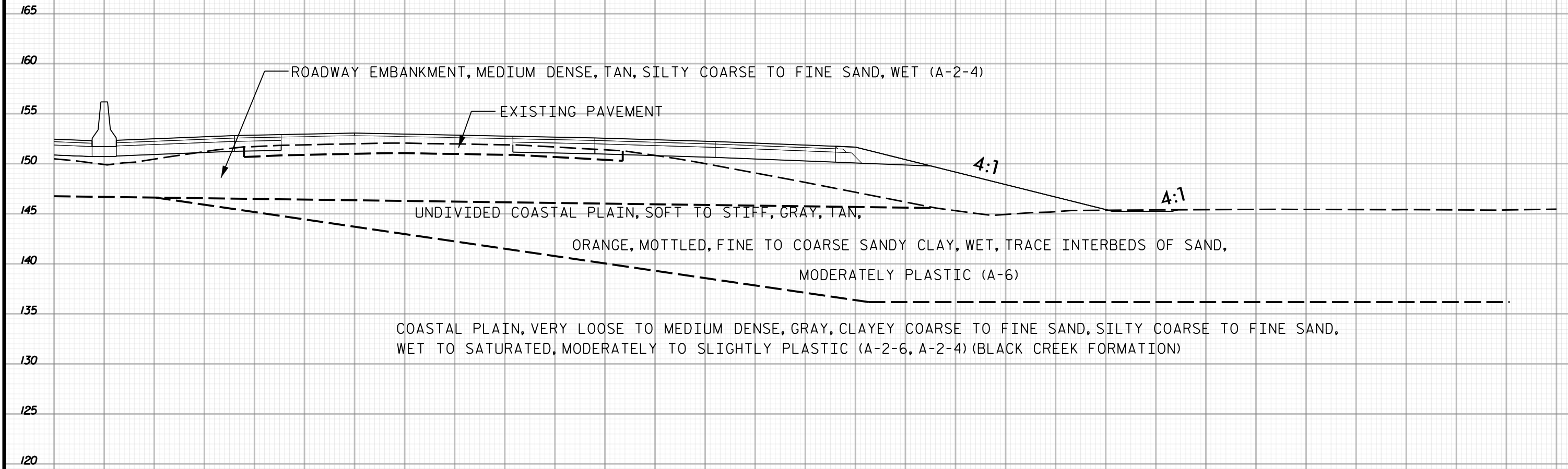

ROADWAY EMBANKMENT, MEDIUM DENSE, TAN, SILTY COARSE TO FINE SAND, WET (A-2-4)

EXISTING PAVEMENT

UNDIVIDED COASTAL PLAIN, SOFT TO STIFF, GRAY, TAN,  
ORANGE, MOTTLED, FINE TO COARSE SANDY CLAY, WET, TRACE INTERBEDS OF SAND,  
MODERATELY PLASTIC (A-6)

COASTAL PLAIN, VERY LOOSE TO MEDIUM DENSE, GRAY, CLAYEY COARSE TO FINE SAND, SILTY COARSE TO FINE SAND,  
WET TO SATURATED, MODERATELY TO SLIGHTLY PLASTIC (A-2-6, A-2-4) (BLACK CREEK FORMATION)

368+50  
2 OF 2

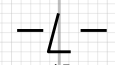

5 0 5 10 15 20 25 30 35 40 45 50 55 60 65 70 75 80 85 90 95 100 105 110 115 120 125 130 135 140 145

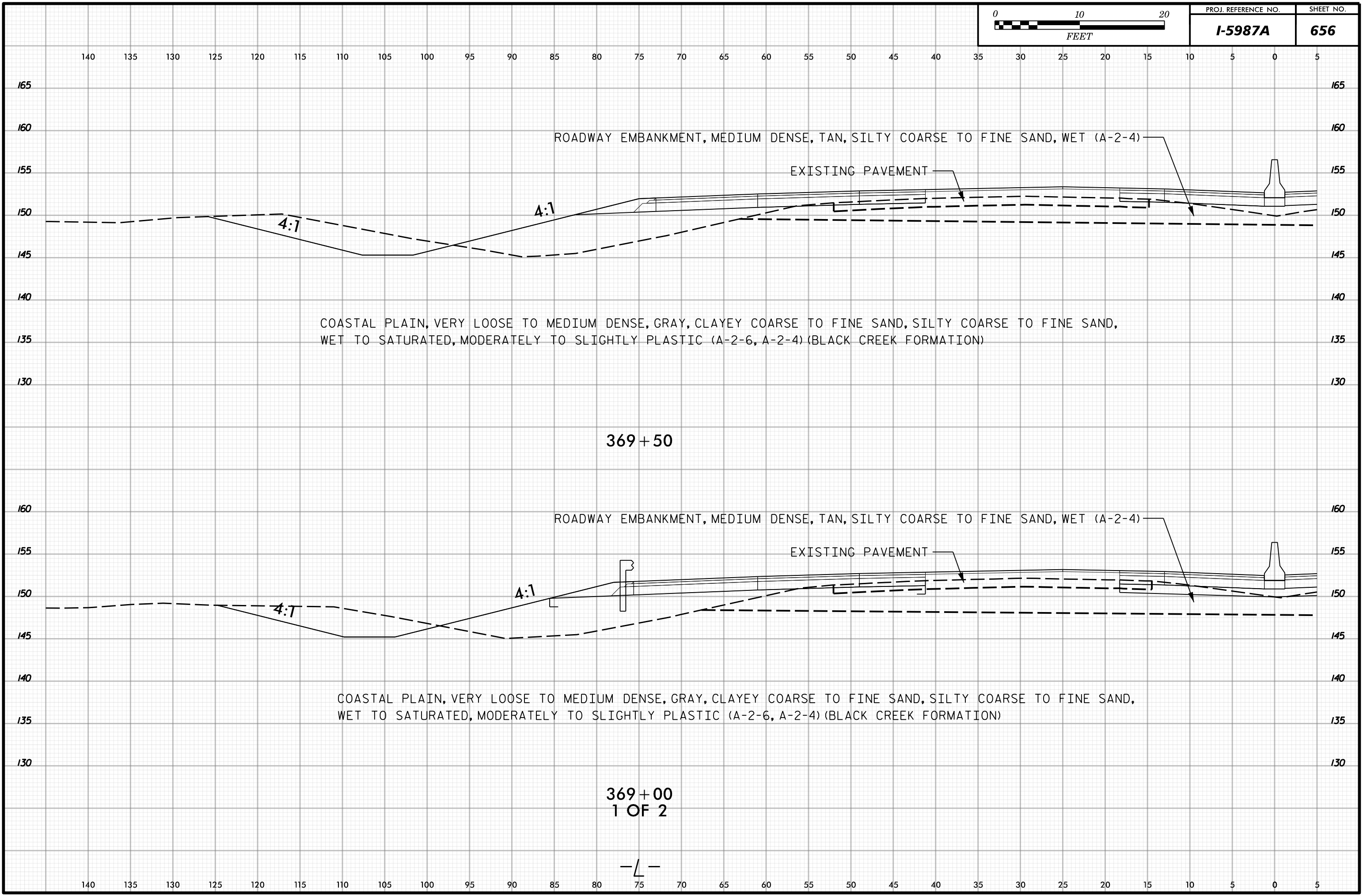

369+50

369+00  
1 OF 2

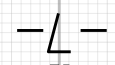

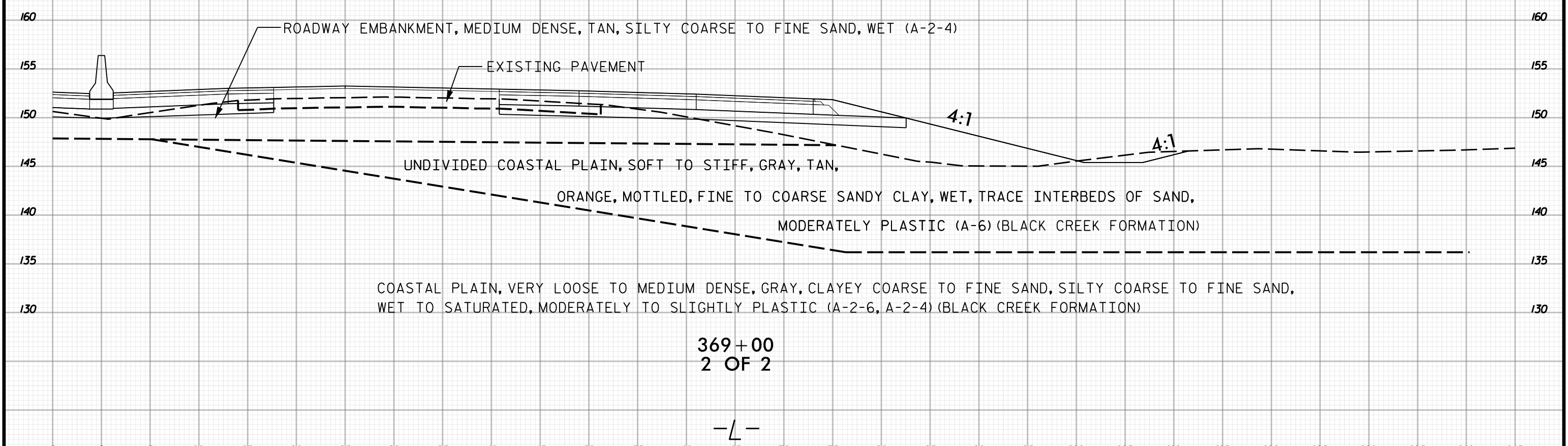
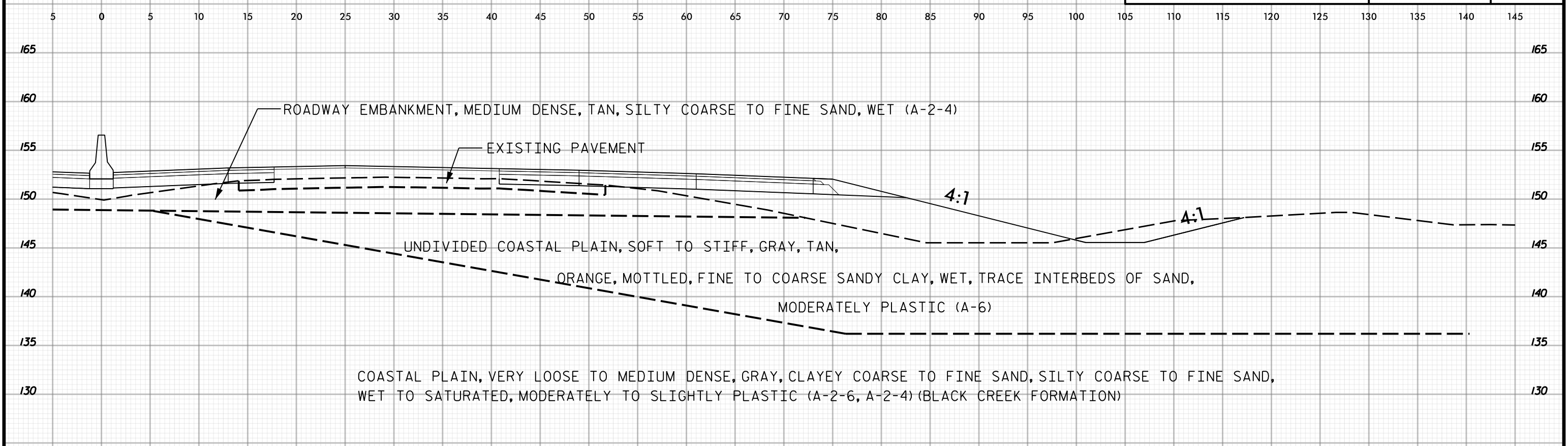

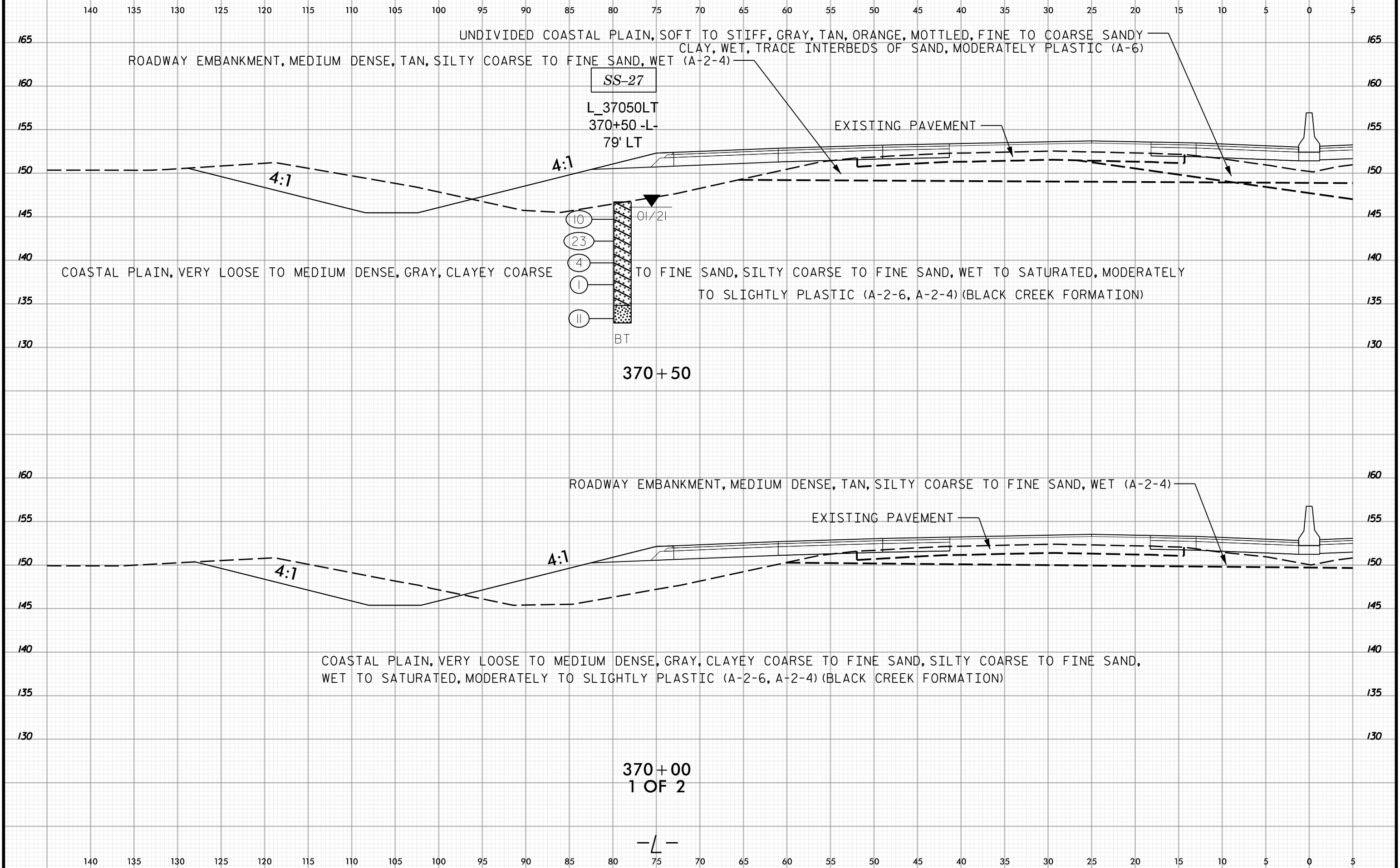

370+00  
1 OF 2

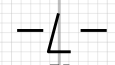

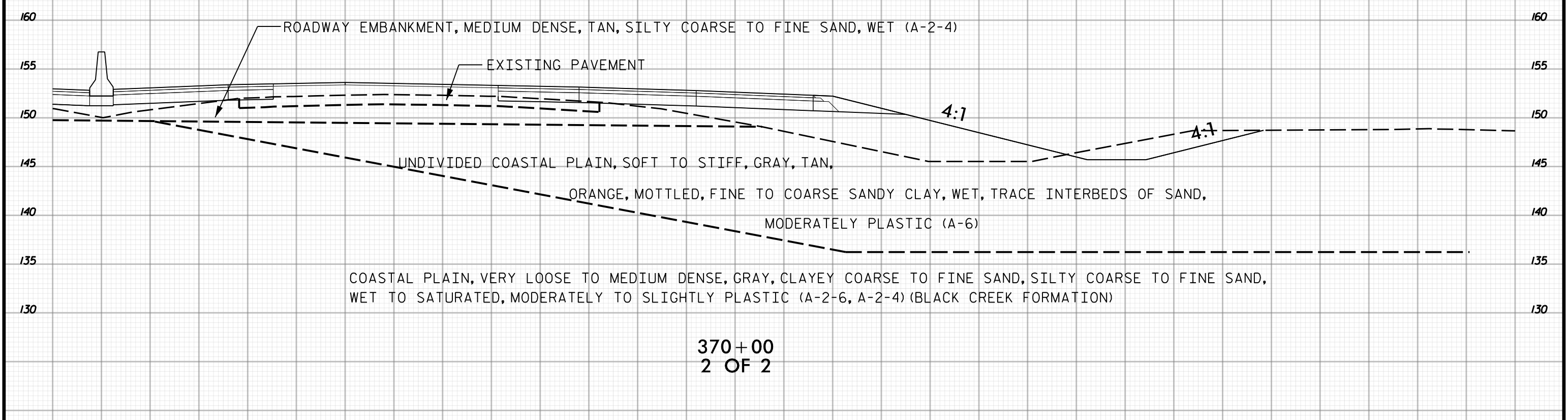
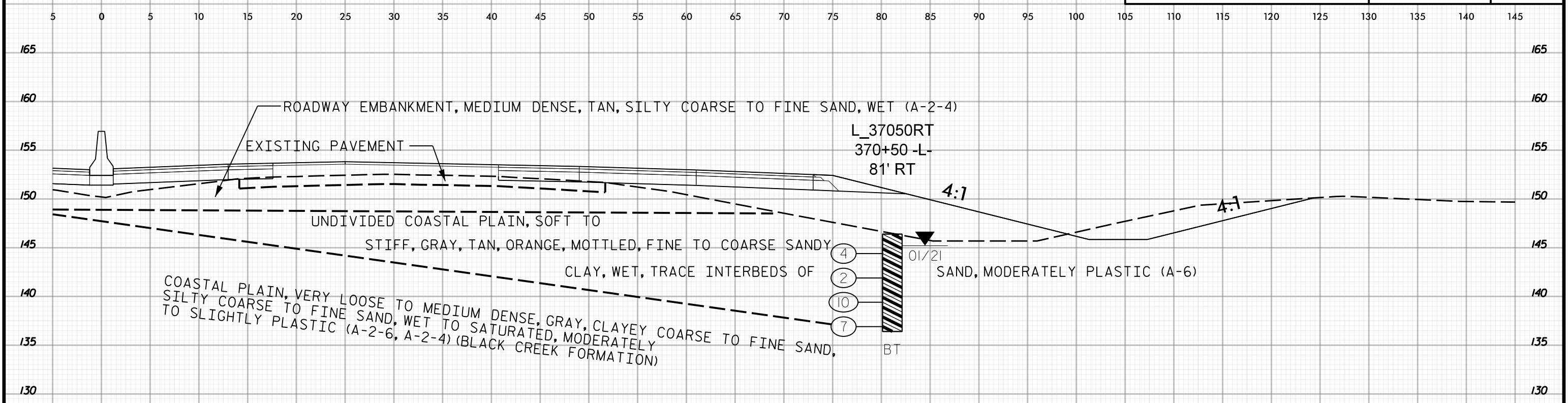

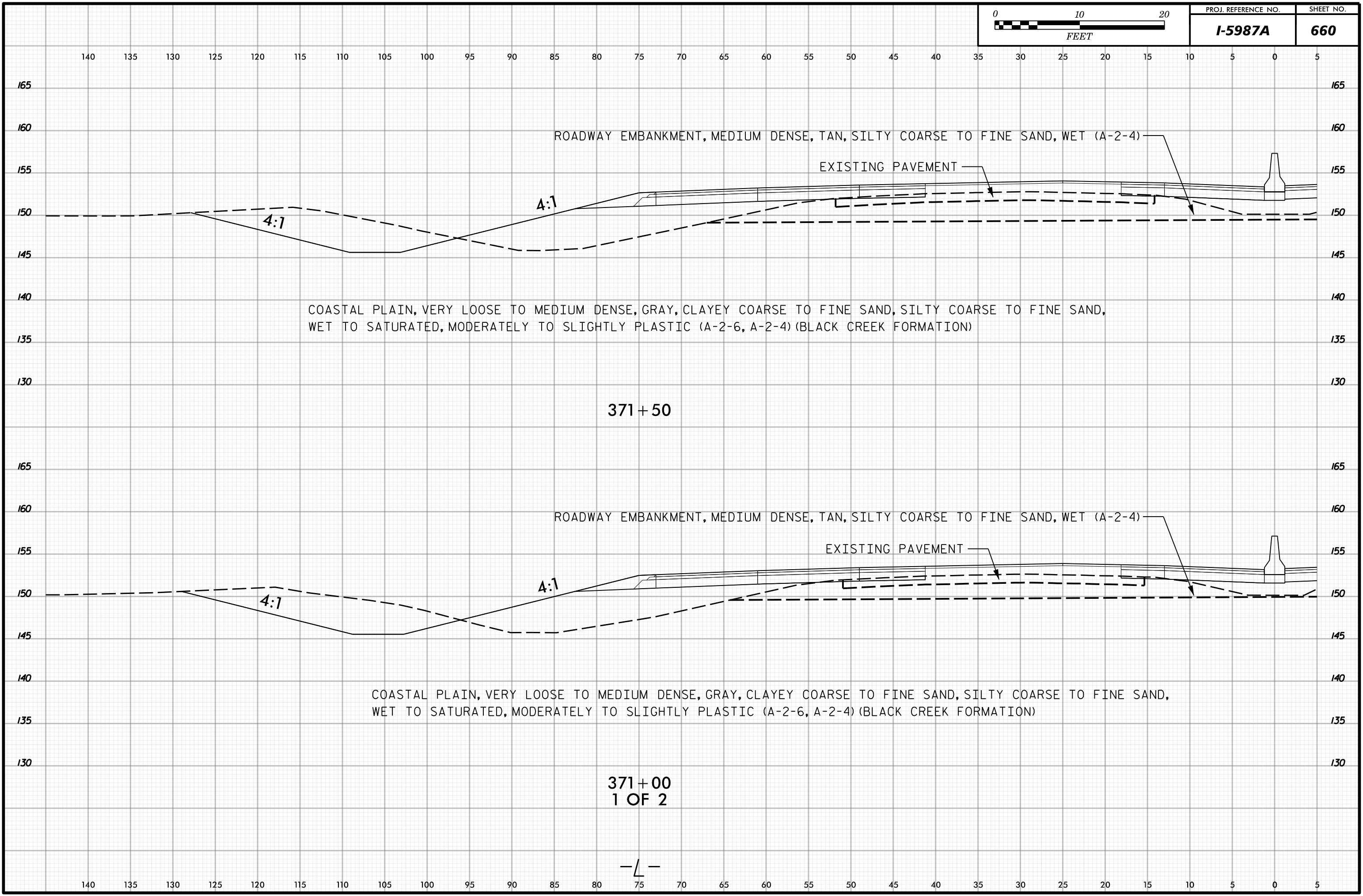

ROADWAY EMBANKMENT, MEDIUM DENSE, TAN, SILTY COARSE TO FINE SAND, WET (A-2-4)

EXISTING PAVEMENT

4:1

4:1

COASTAL PLAIN, VERY LOOSE TO MEDIUM DENSE, GRAY, CLAYEY COARSE TO FINE SAND, SILTY COARSE TO FINE SAND, WET TO SATURATED, MODERATELY TO SLIGHTLY PLASTIC (A-2-6, A-2-4) (BLACK CREEK FORMATION)

371+50

ROADWAY EMBANKMENT, MEDIUM DENSE, TAN, SILTY COARSE TO FINE SAND, WET (A-2-4)

EXISTING PAVEMENT

4:1

4:1

COASTAL PLAIN, VERY LOOSE TO MEDIUM DENSE, GRAY, CLAYEY COARSE TO FINE SAND, SILTY COARSE TO FINE SAND, WET TO SATURATED, MODERATELY TO SLIGHTLY PLASTIC (A-2-6, A-2-4) (BLACK CREEK FORMATION)

371+00  
1 OF 2

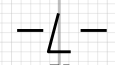

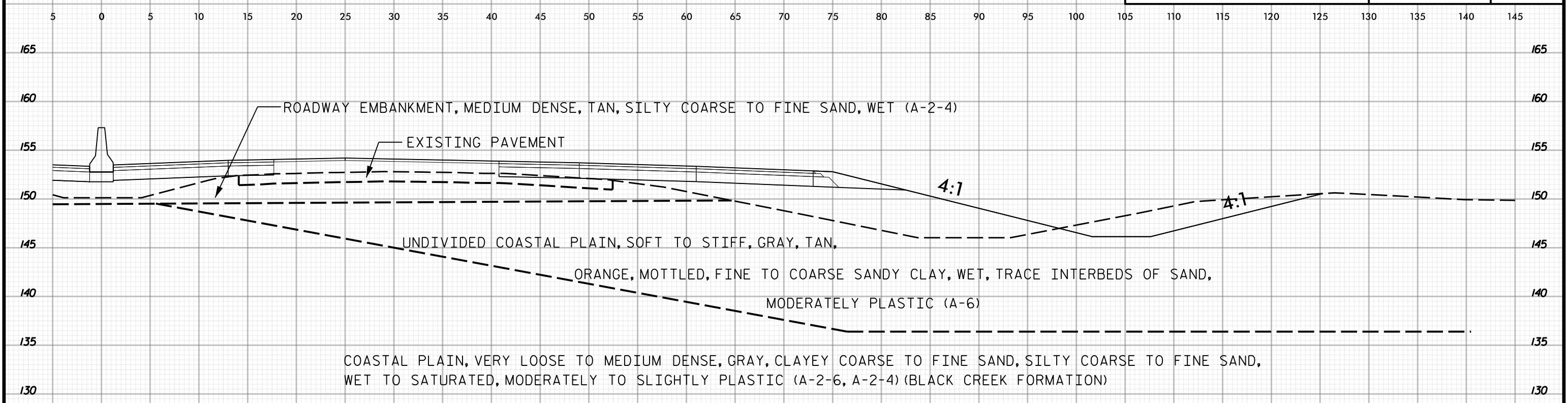

371+50

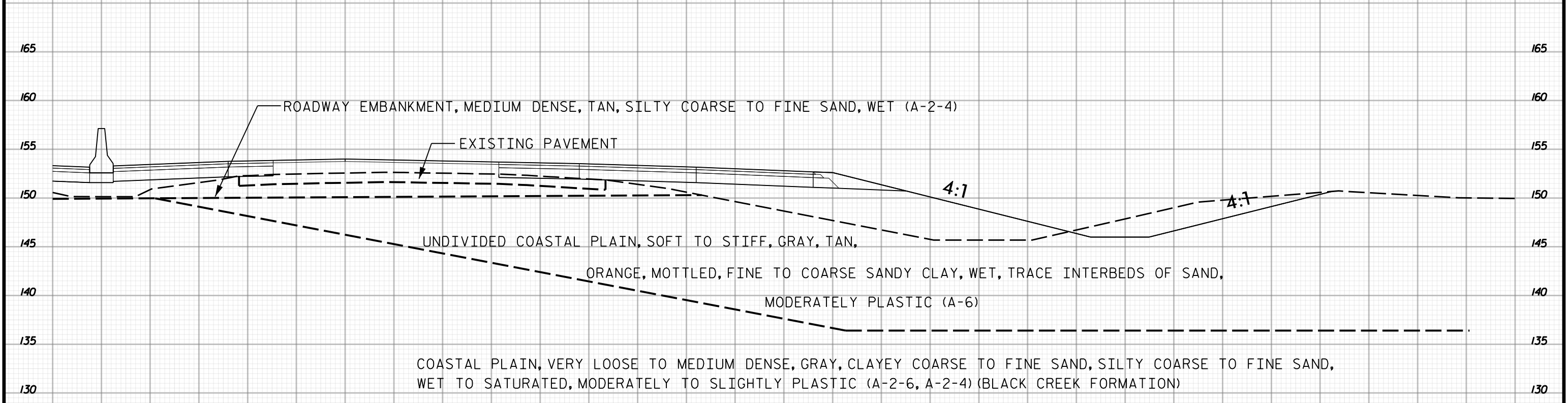

371+00  
2 OF 2

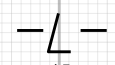



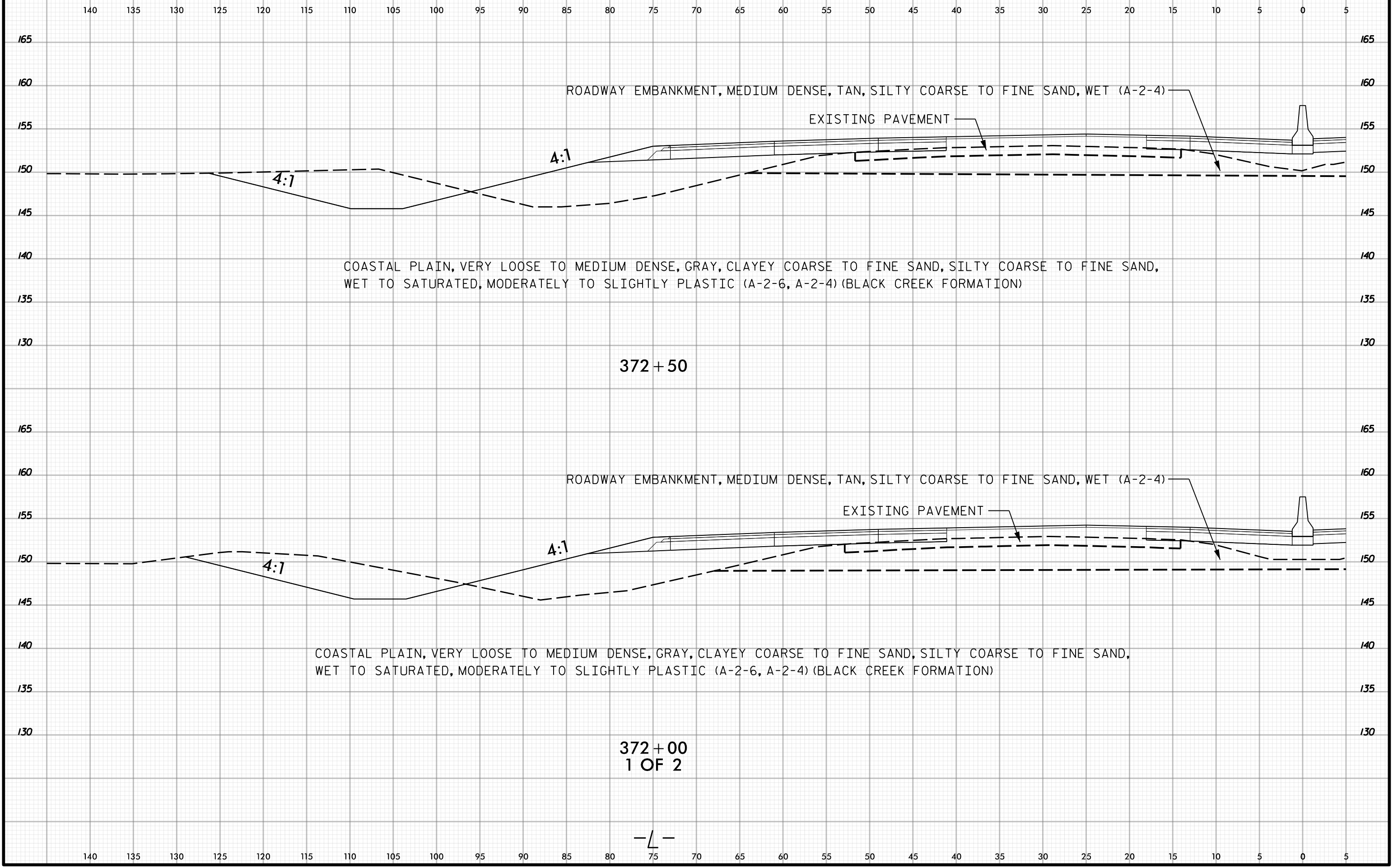

372+50

372+00  
1 OF 2

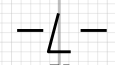



PROJ. REFERENCE NO.	SHEET NO.
I-5987A	663

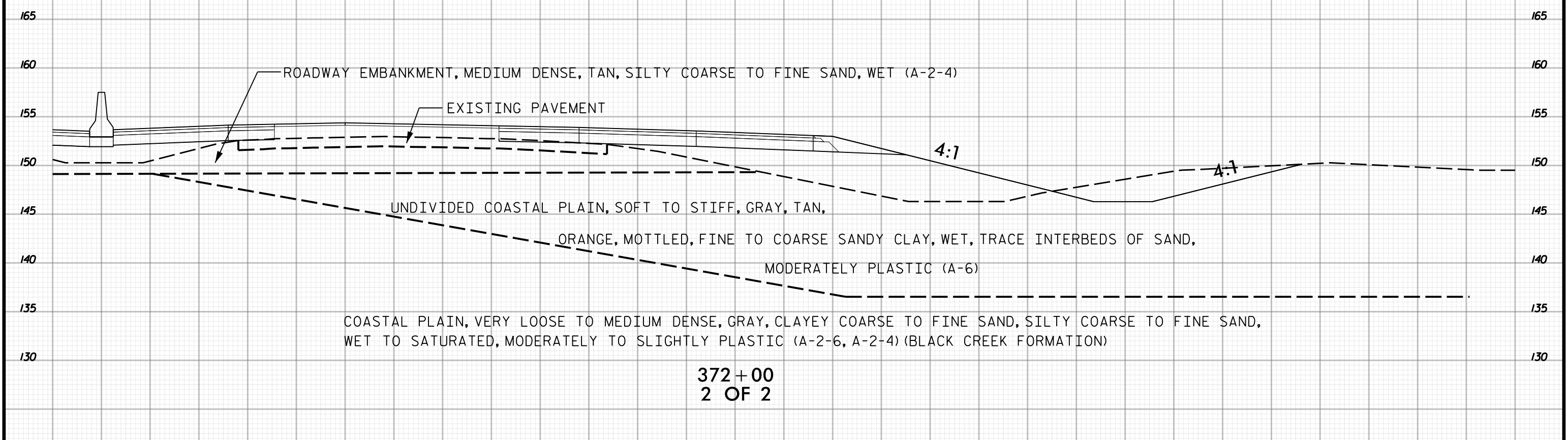
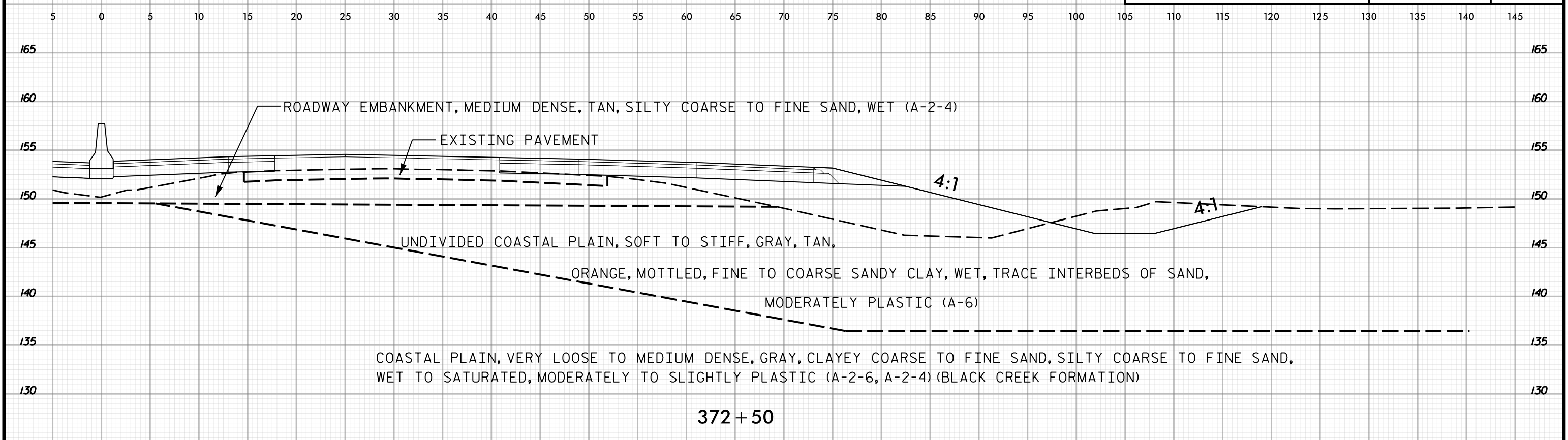



140 135 130 125 120 115 110 105 100 95 90 85 80 75 70 65 60 55 50 45 40 35 30 25 20 15 10 5 0 5

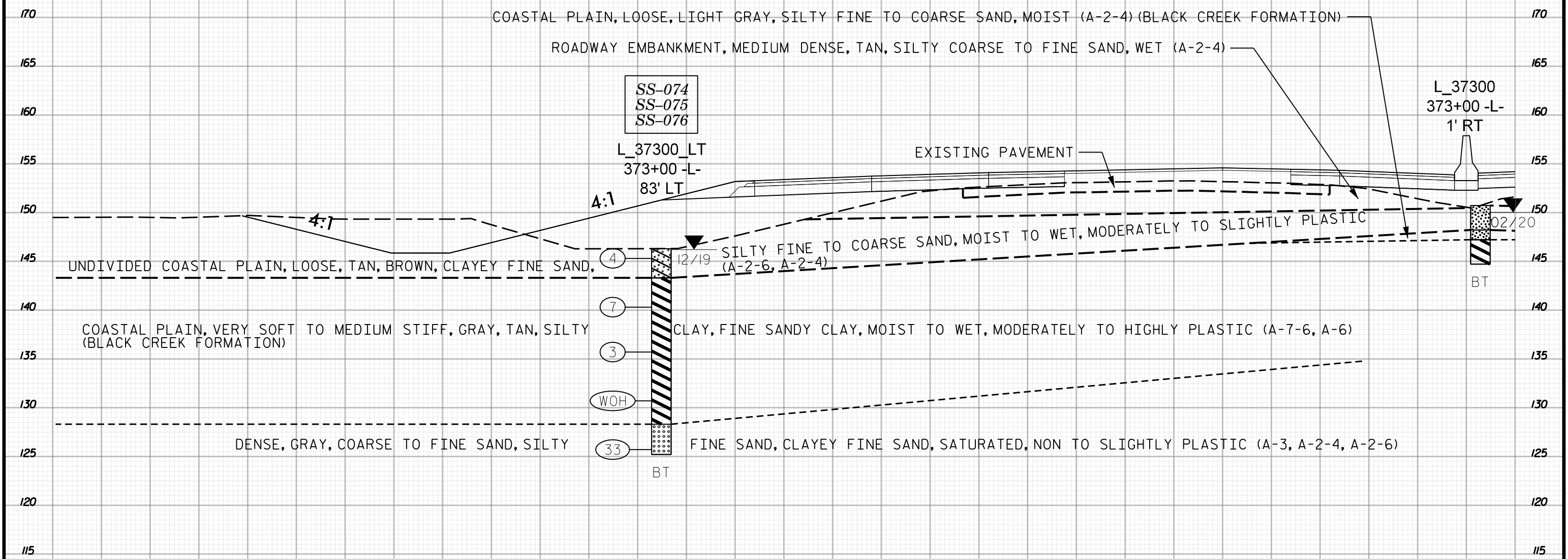

373+00  
1 OF 2

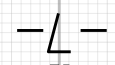

140 135 130 125 120 115 110 105 100 95 90 85 80 75 70 65 60 55 50 45 40 35 30 25 20 15 10 5 0 5

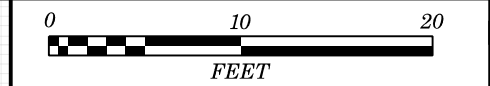

5 0 5 10 15 20 25 30 35 40 45 50 55 60 65 70 75 80 85 90 95 100 105 110 115 120 125 130 135 140 145

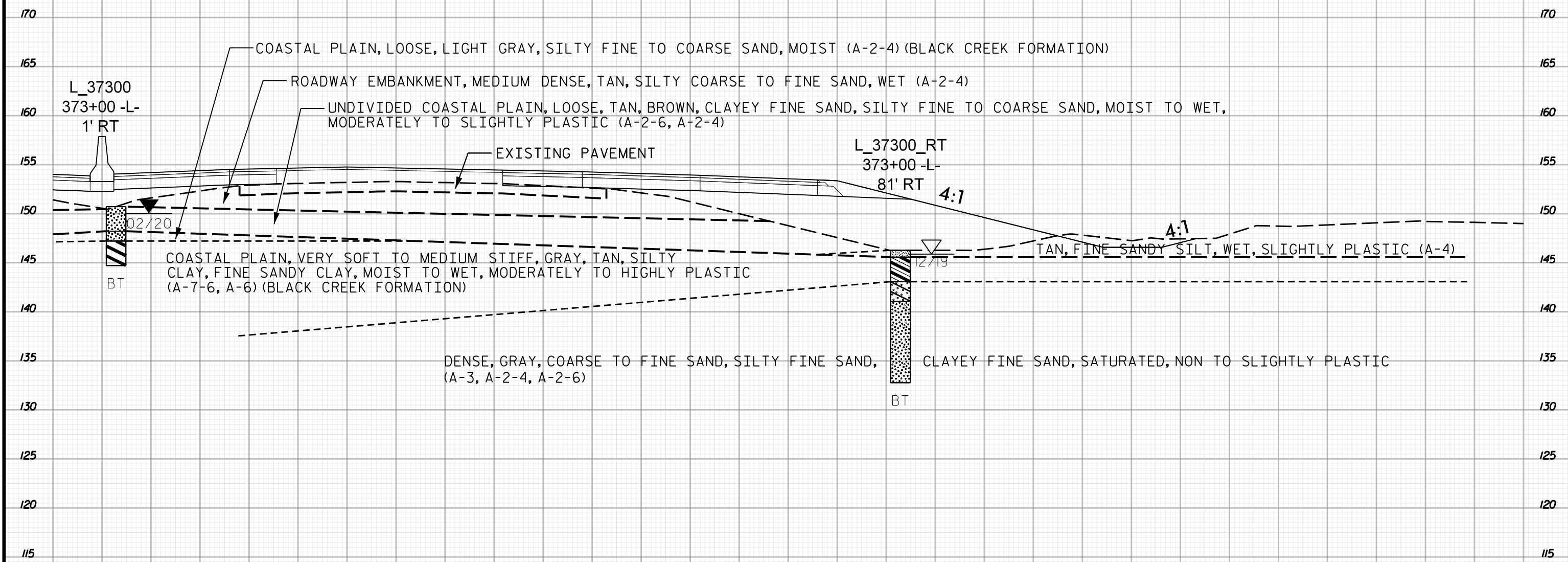

373+00  
2 OF 2

-L-

5 0 5 10 15 20 25 30 35 40 45 50 55 60 65 70 75 80 85 90 95 100 105 110 115 120 125 130 135 140 145

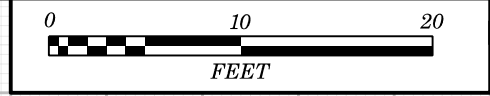

140 135 130 125 120 115 110 105 100 95 90 85 80 75 70 65 60 55 50 45 40 35 30 25 20 15 10 5 0 5

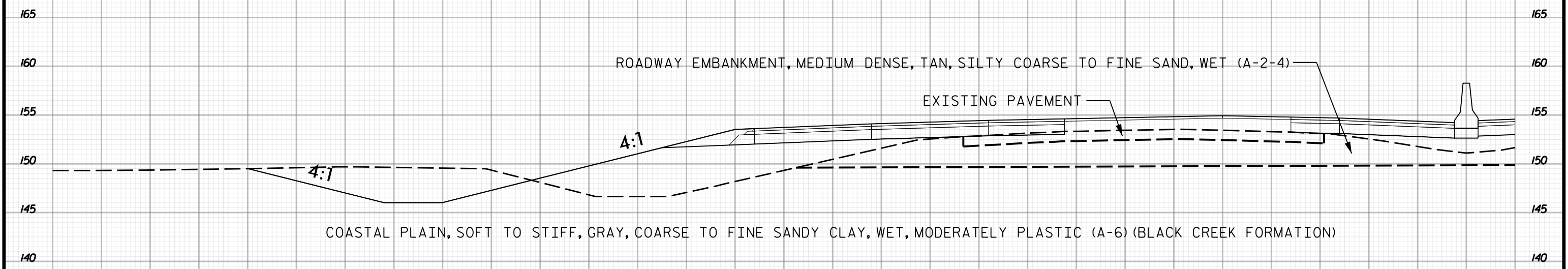

374+00

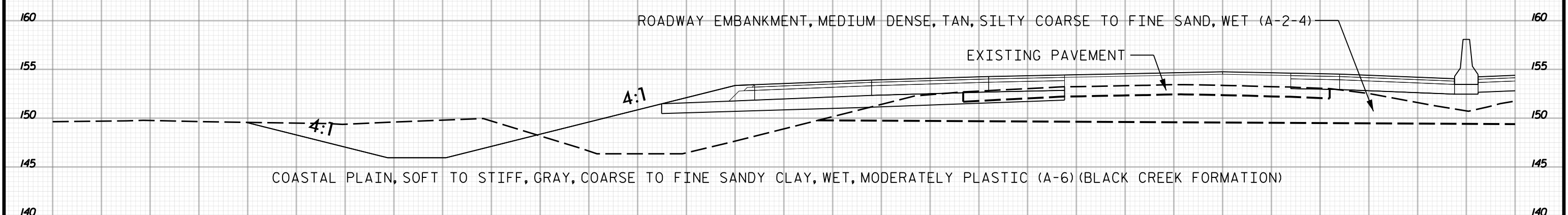

373+50  
1 OF 2

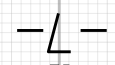

140 135 130 125 120 115 110 105 100 95 90 85 80 75 70 65 60 55 50 45 40 35 30 25 20 15 10 5 0 5

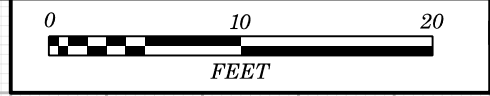

PROJ. REFERENCE NO.	SHEET NO.
I-5987A	667

5 0 5 10 15 20 25 30 35 40 45 50 55 60 65 70 75 80 85 90 95 100 105 110 115 120 125 130 135 140 145

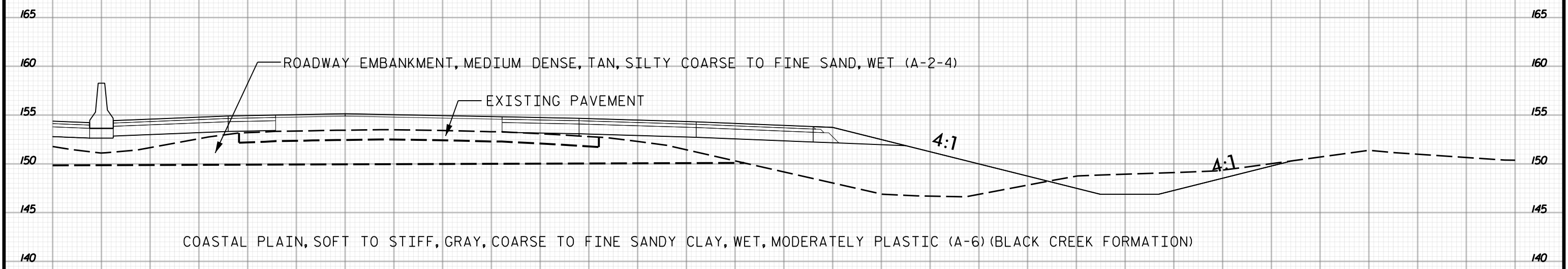

374+00

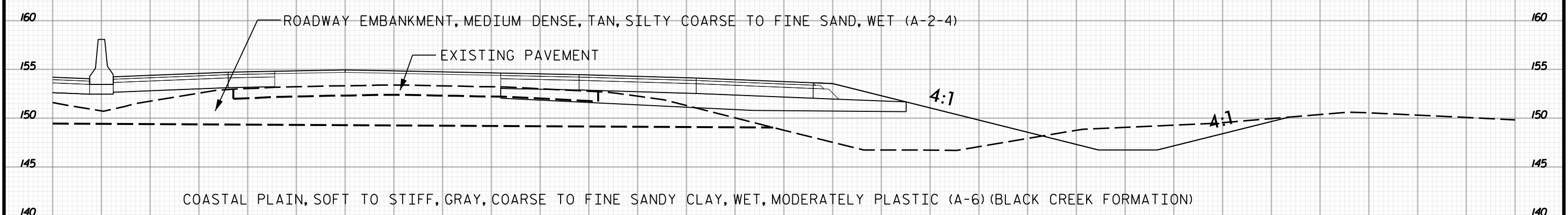

373+50  
2 OF 2

-L-

5 0 5 10 15 20 25 30 35 40 45 50 55 60 65 70 75 80 85 90 95 100 105 110 115 120 125 130 135 140 145

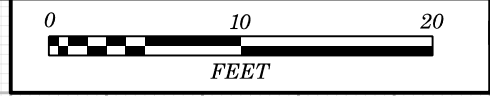

PROJ. REFERENCE NO.	SHEET NO.
I-5987A	668

140 135 130 125 120 115 110 105 100 95 90 85 80 75 70 65 60 55 50 45 40 35 30 25 20 15 10 5 0 5

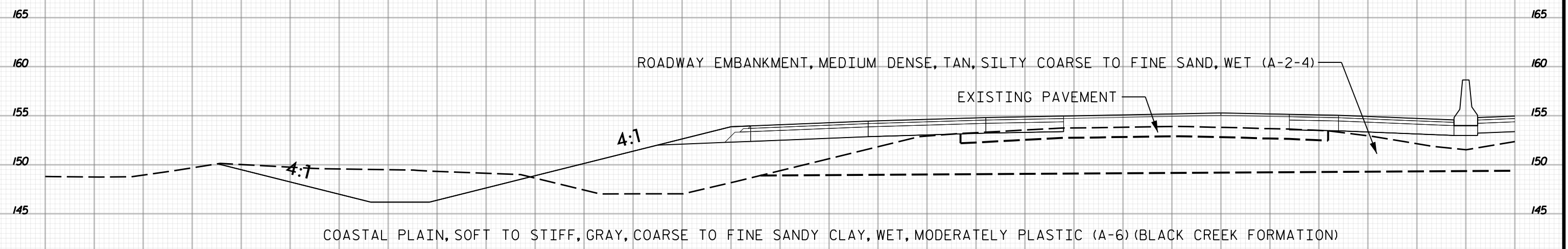

375+00

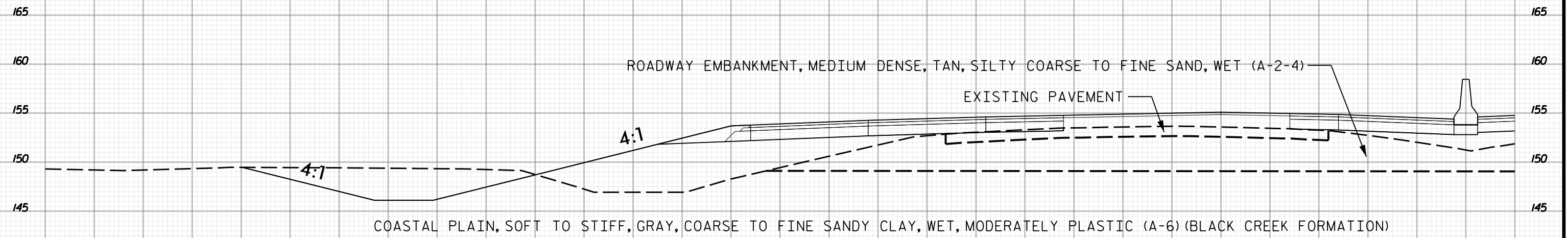

374+50  
1 OF 2

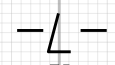

140 135 130 125 120 115 110 105 100 95 90 85 80 75 70 65 60 55 50 45 40 35 30 25 20 15 10 5 0 5



PROJ. REFERENCE NO.	SHEET NO.
I-5987A	669

5 0 5 10 15 20 25 30 35 40 45 50 55 60 65 70 75 80 85 90 95 100 105 110 115 120 125 130 135 140 145

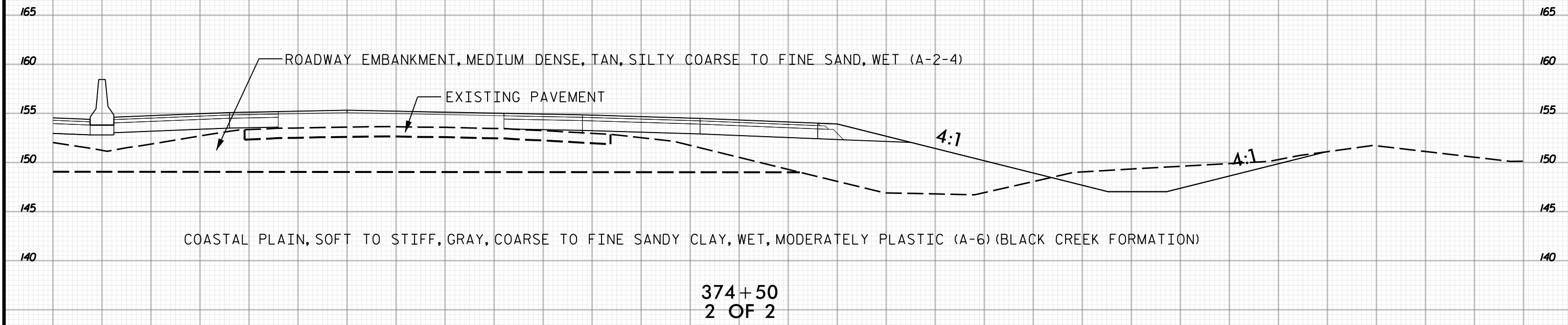
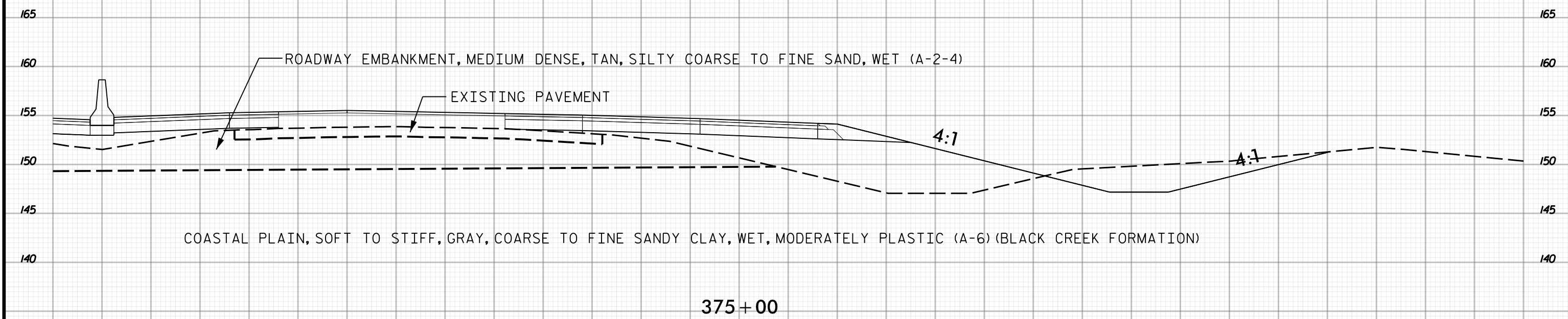

5 0 5 10 15 20 25 30 35 40 45 50 55 60 65 70 75 80 85 90 95 100 105 110 115 120 125 130 135 140 145

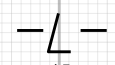





140 135 130 125 120 115 110 105 100 95 90 85 80 75 70 65 60 55 50 45 40 35 30 25 20 15 10 5 0 5

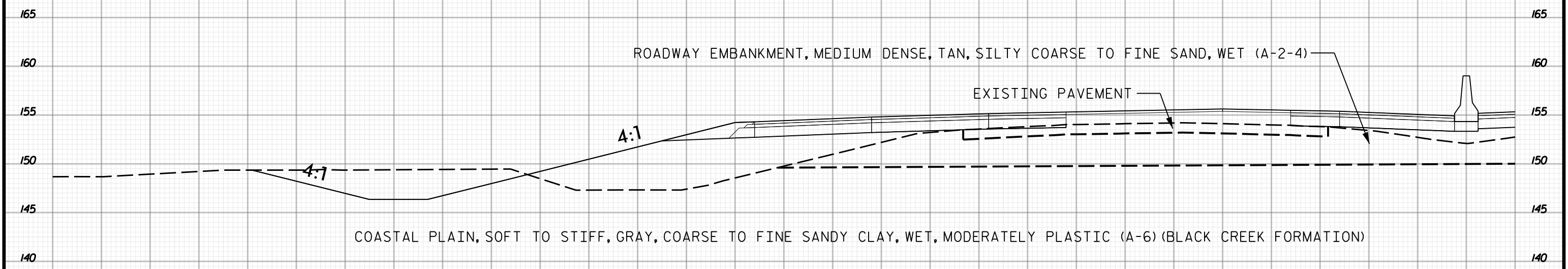

376+00

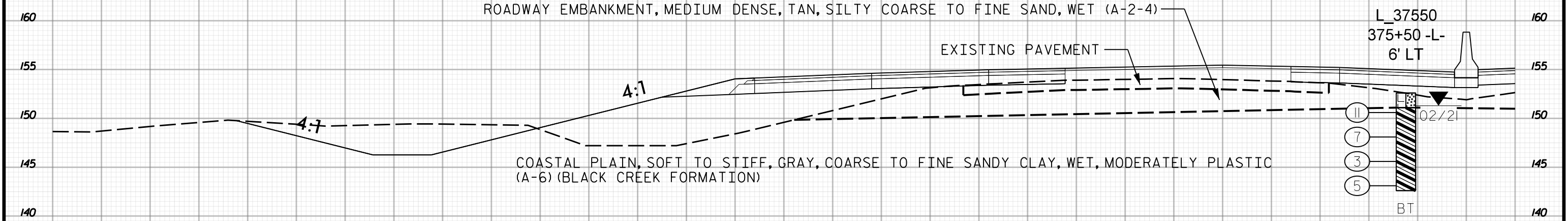

375+50  
1 OF 2

140 135 130 125 120 115 110 105 100 95 90 85 80 75 70 65 60 55 50 45 40 35 30 25 20 15 10 5 0 5



PROJ. REFERENCE NO.	SHEET NO.
I-5987A	671

5 0 5 10 15 20 25 30 35 40 45 50 55 60 65 70 75 80 85 90 95 100 105 110 115 120 125 130 135 140 145

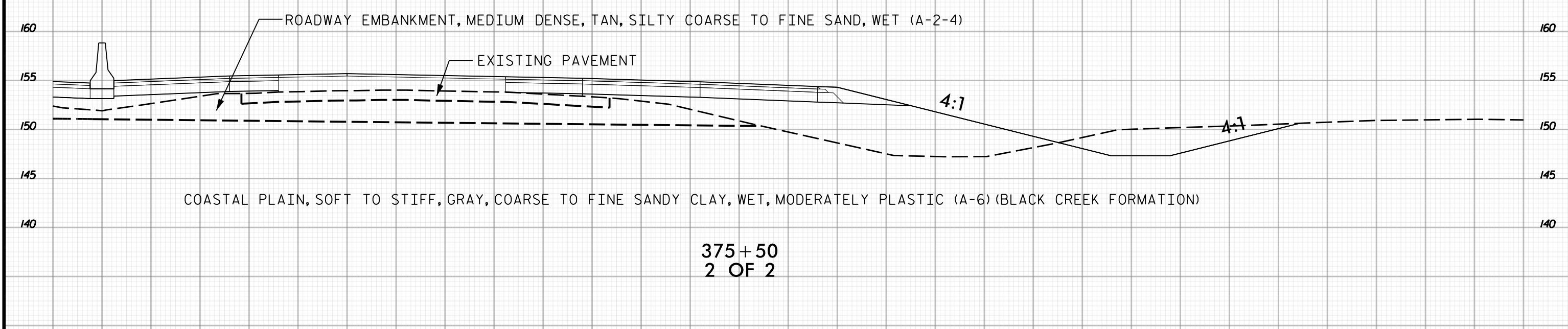
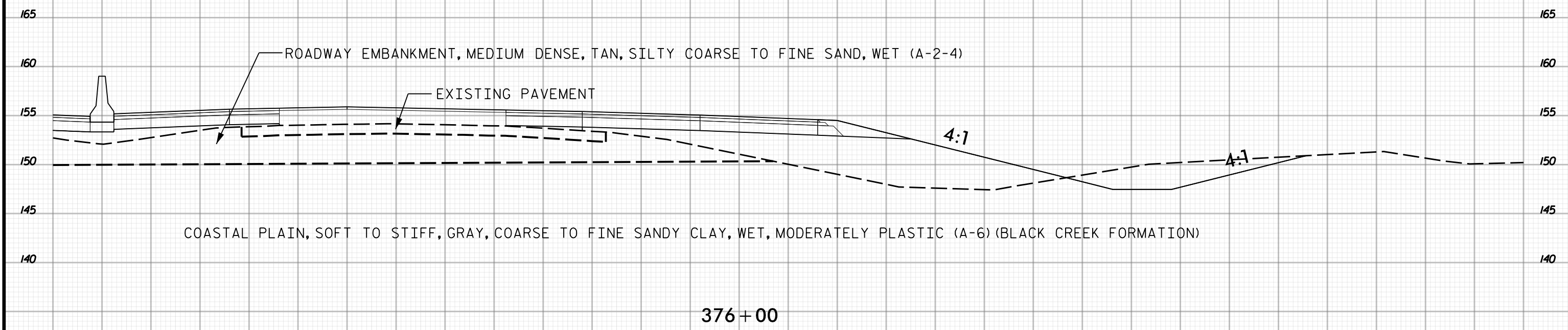

5 0 5 10 15 20 25 30 35 40 45 50 55 60 65 70 75 80 85 90 95 100 105 110 115 120 125 130 135 140 145

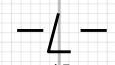



PROJ. REFERENCE NO.	SHEET NO.
I-5987A	672

140 135 130 125 120 115 110 105 100 95 90 85 80 75 70 65 60 55 50 45 40 35 30 25 20 15 10 5 0 5

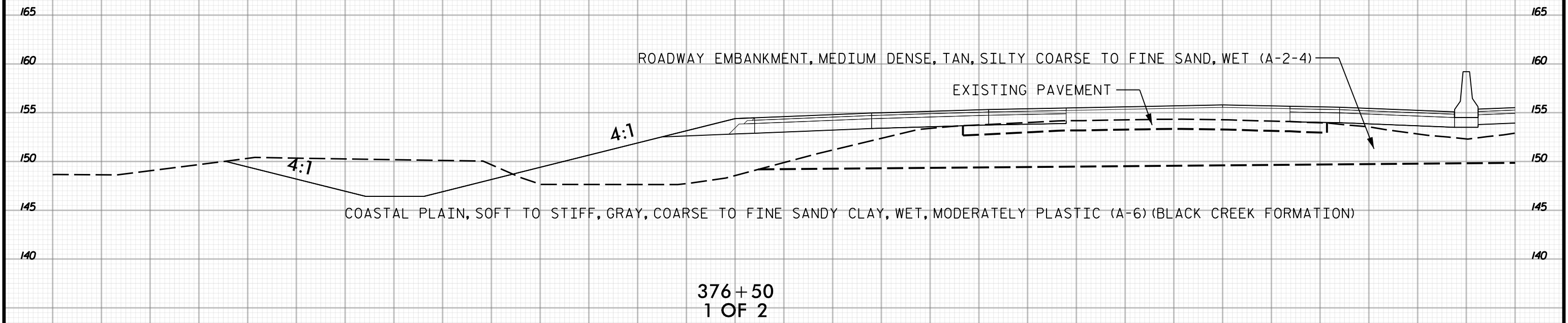
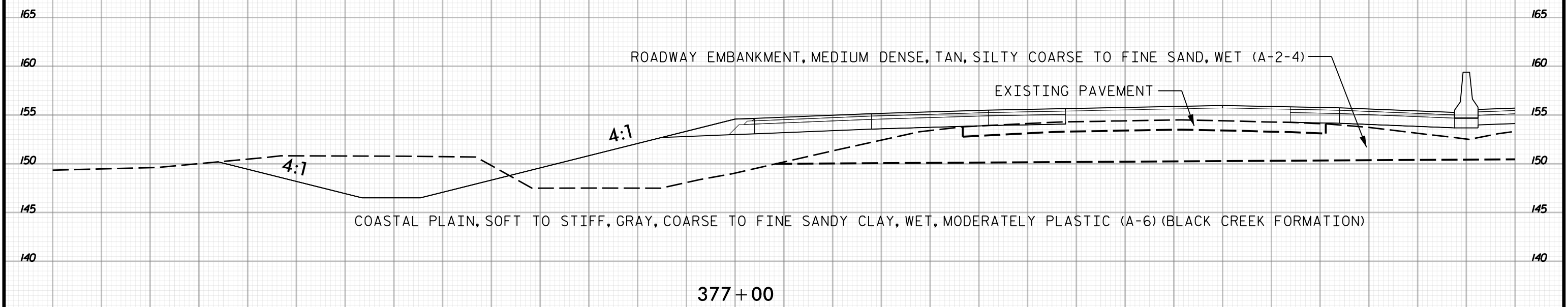

140 135 130 125 120 115 110 105 100 95 90 85 80 75 70 65 60 55 50 45 40 35 30 25 20 15 10 5 0 5

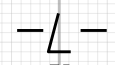



5 0 5 10 15 20 25 30 35 40 45 50 55 60 65 70 75 80 85 90 95 100 105 110 115 120 125 130 135 140 145

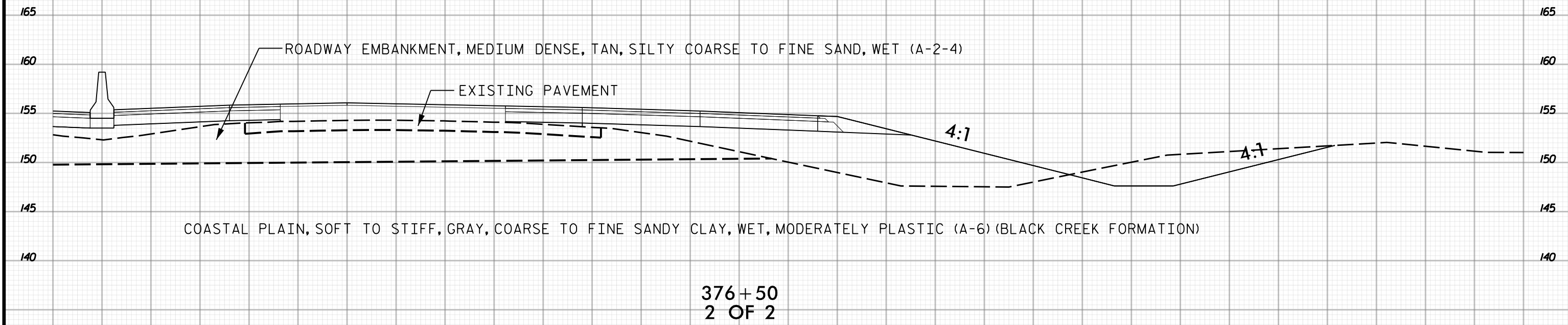
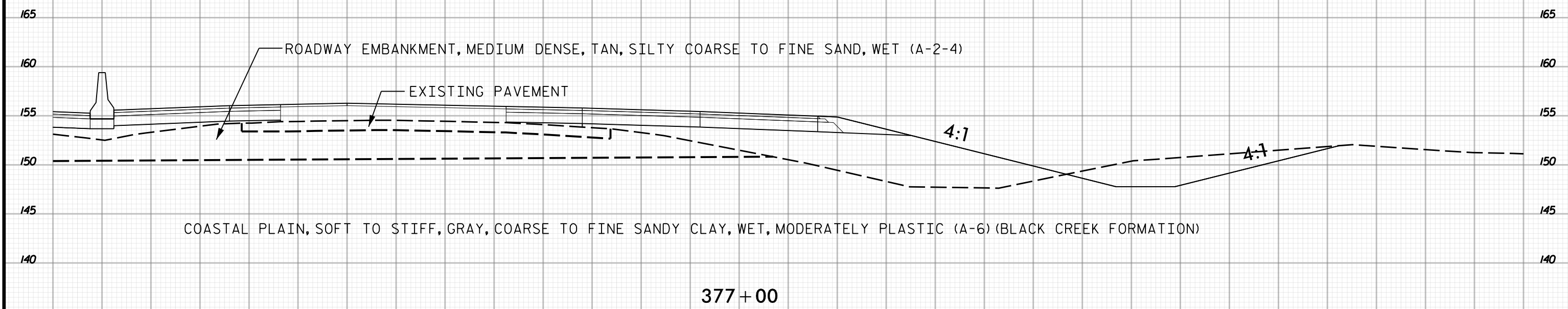

5 0 5 10 15 20 25 30 35 40 45 50 55 60 65 70 75 80 85 90 95 100 105 110 115 120 125 130 135 140 145

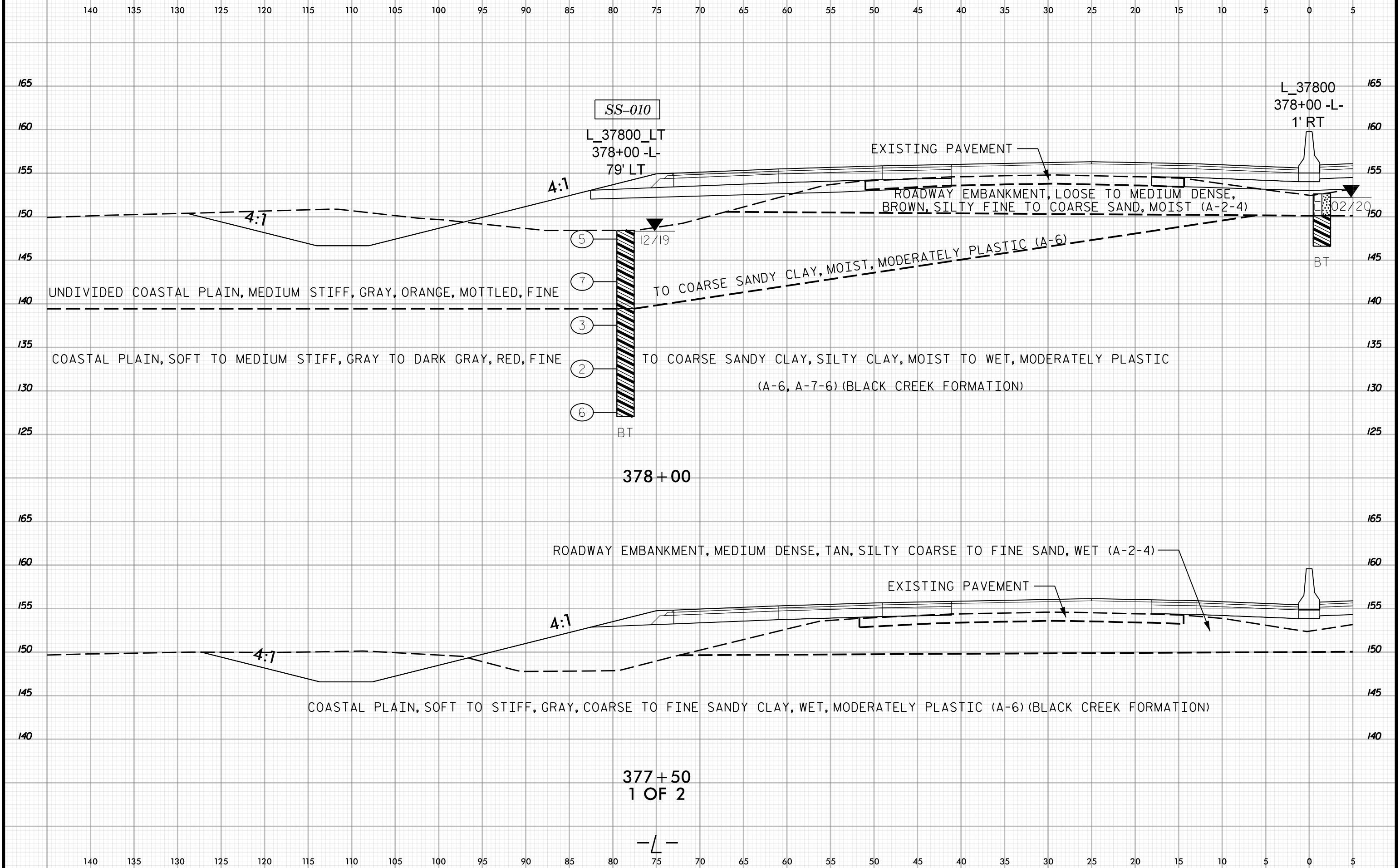

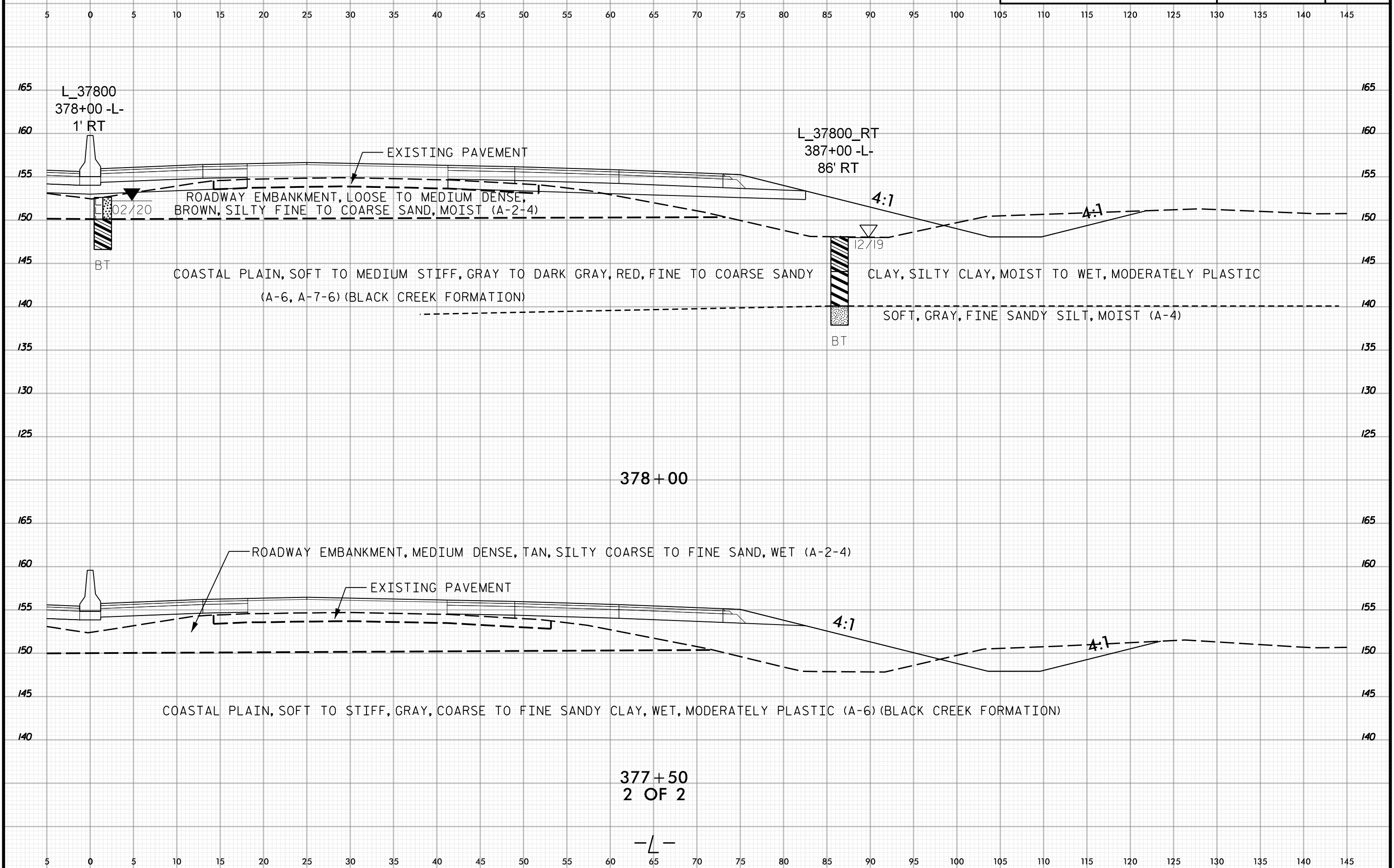

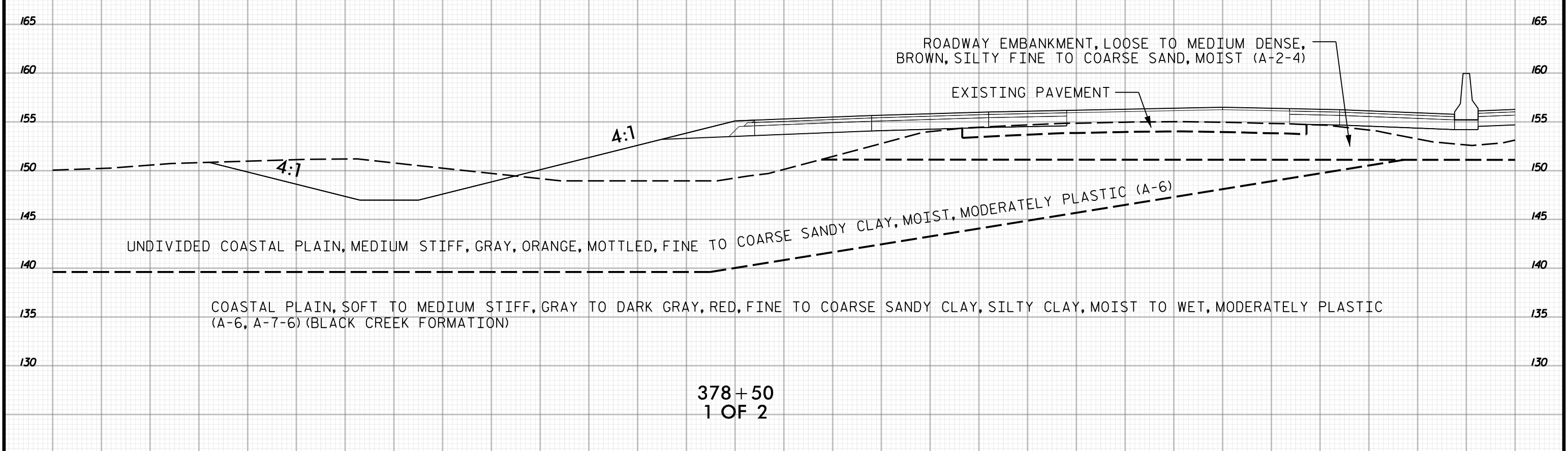
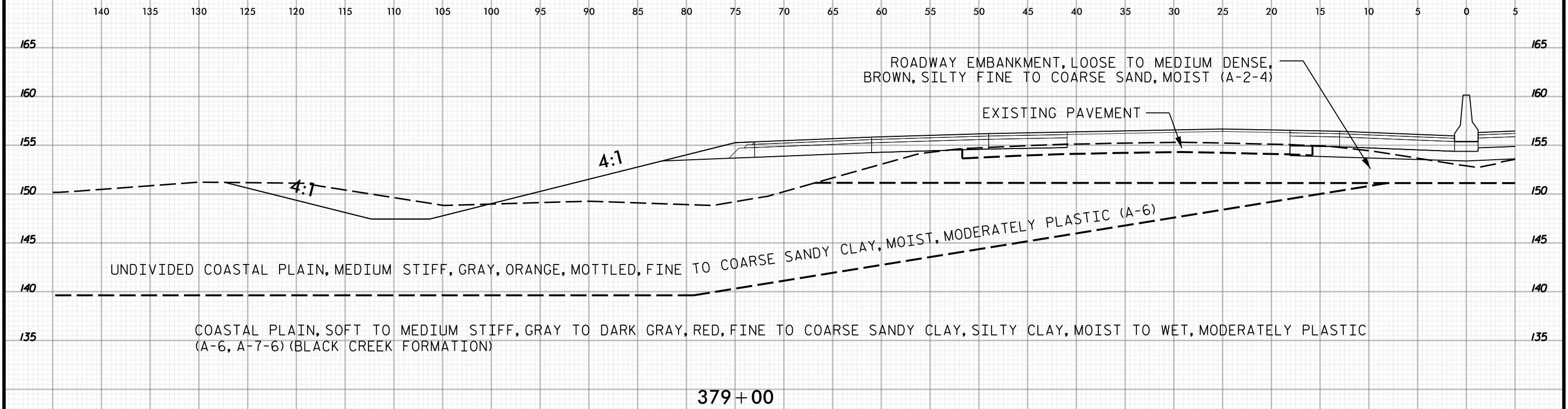

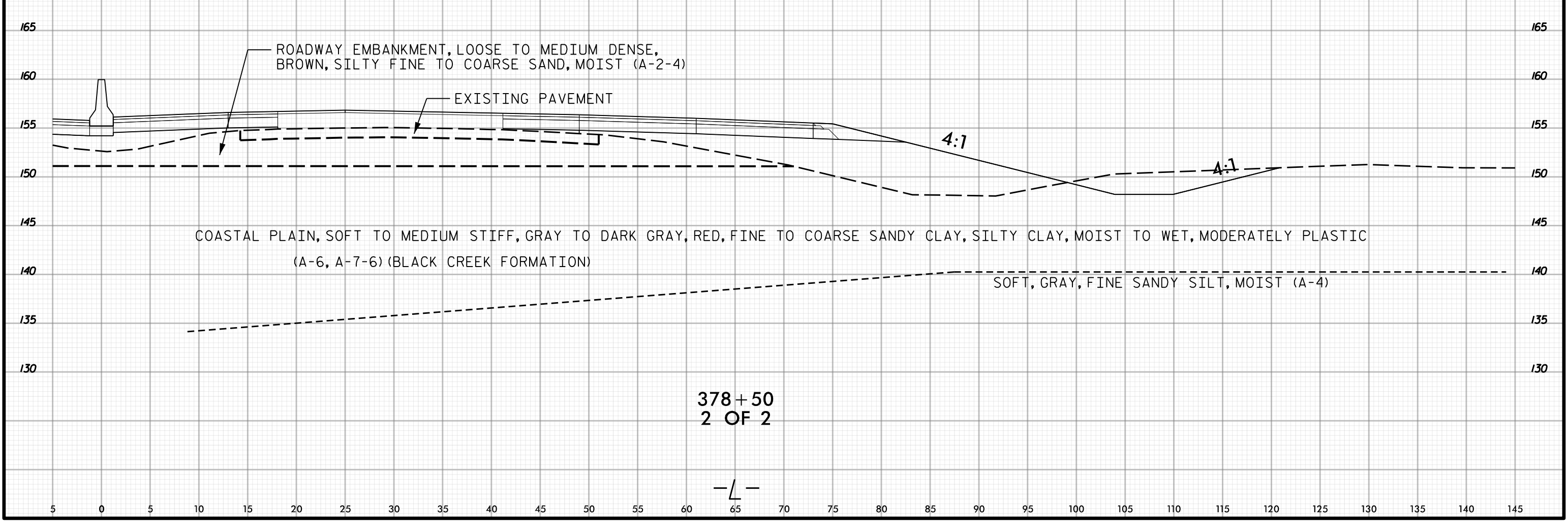
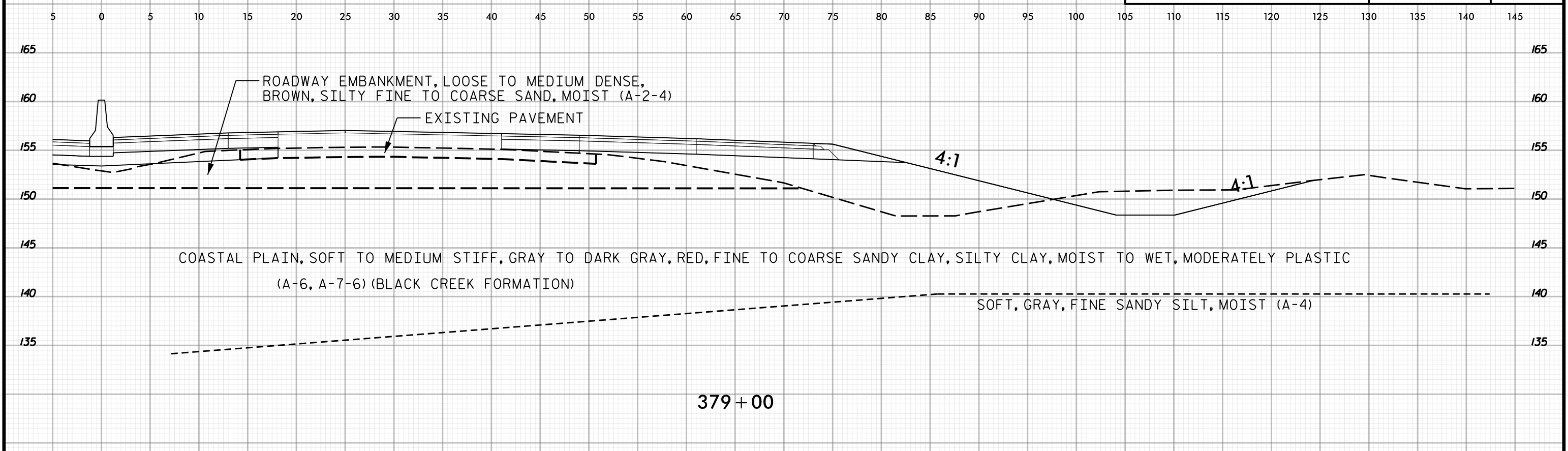



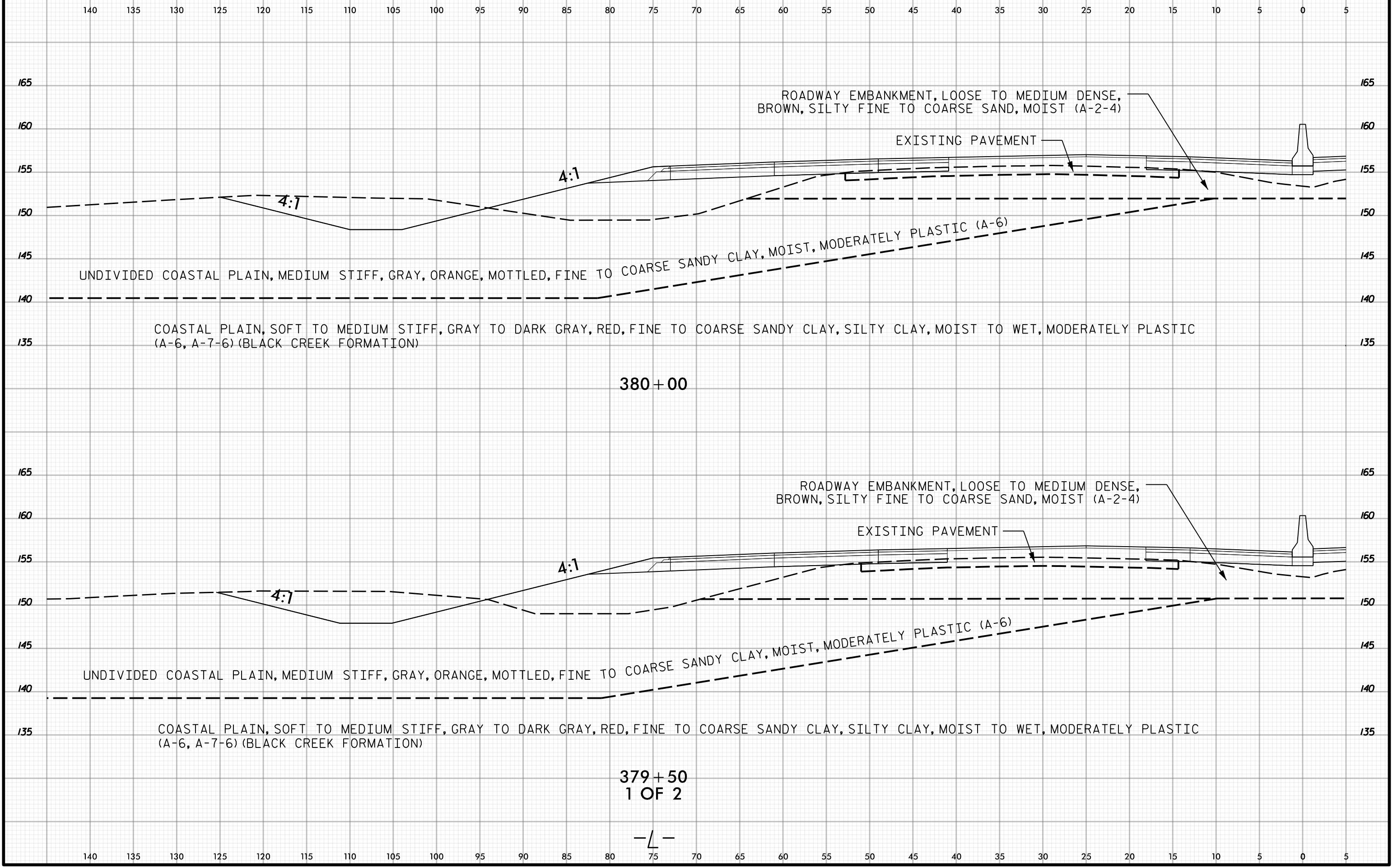

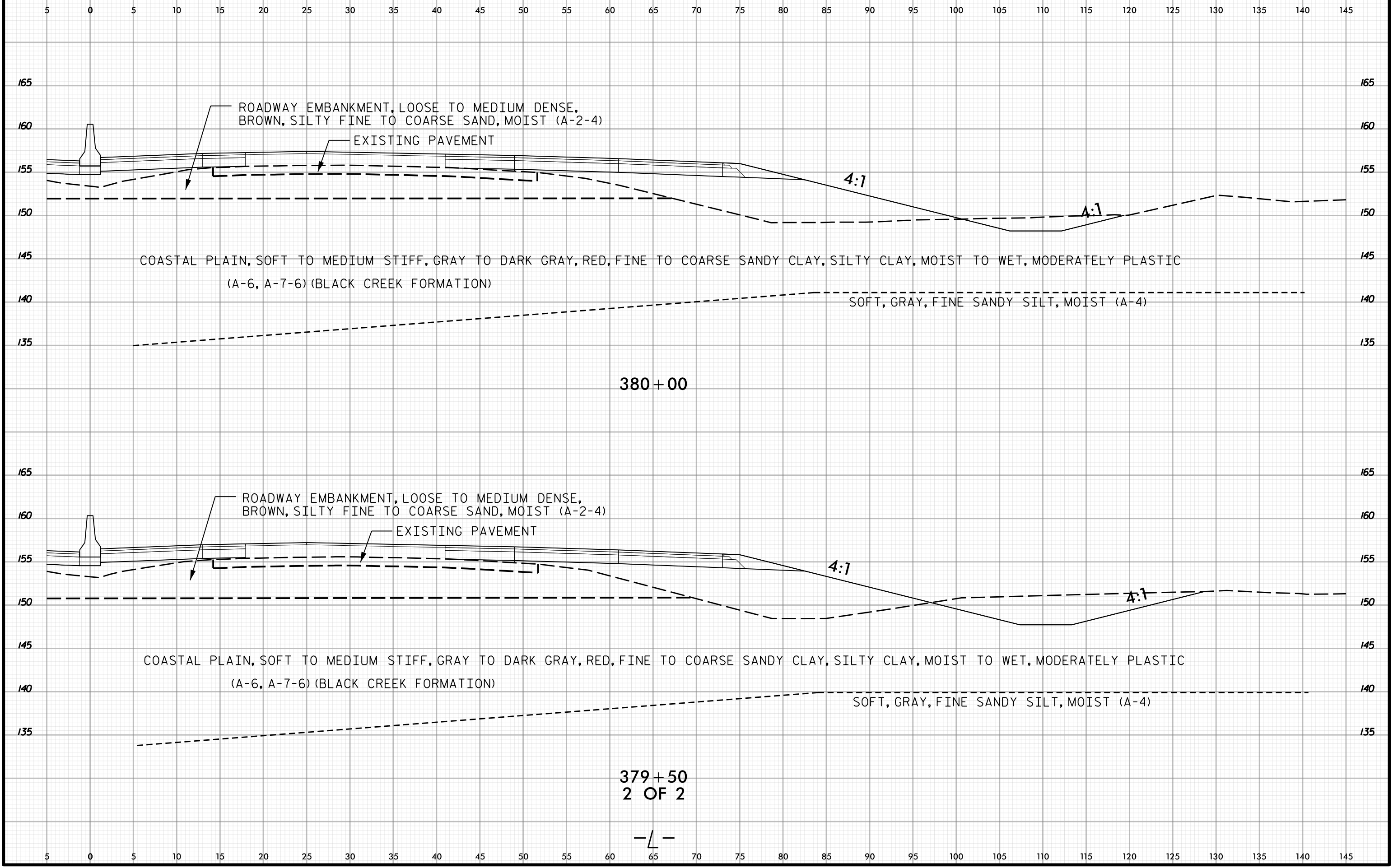
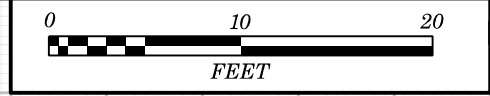



140 135 130 125 120 115 110 105 100 95 90 85 80 75 70 65 60 55 50 45 40 35 30 25 20 15 10 5 0 5

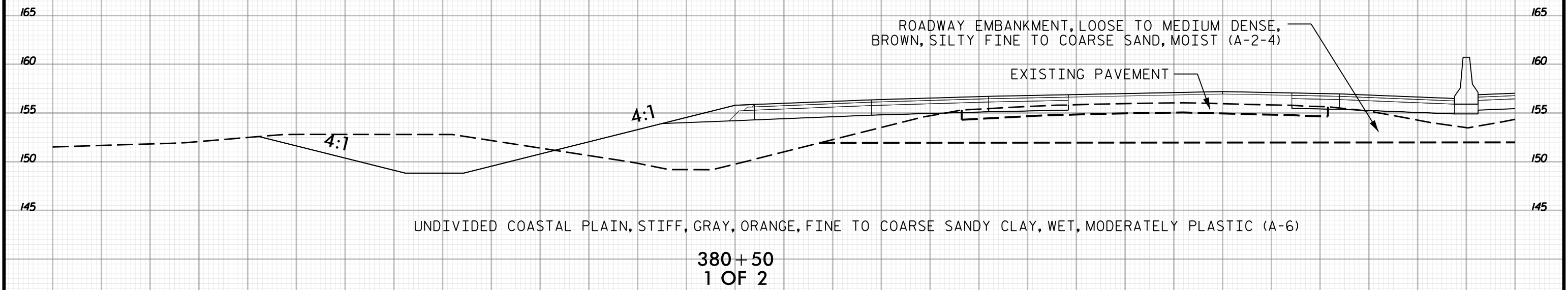
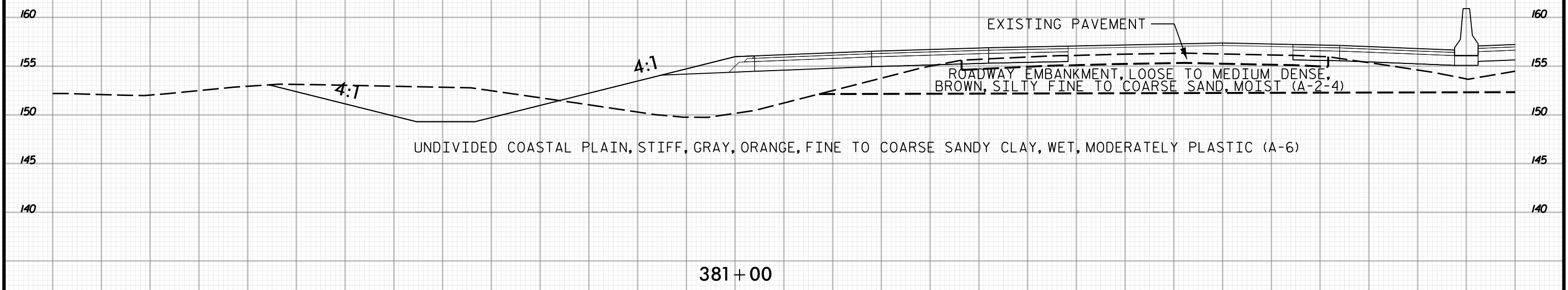

140 135 130 125 120 115 110 105 100 95 90 85 80 75 70 65 60 55 50 45 40 35 30 25 20 15 10 5 0 5



5 0 5 10 15 20 25 30 35 40 45 50 55 60 65 70 75 80 85 90 95 100 105 110 115 120 125 130 135 140 145

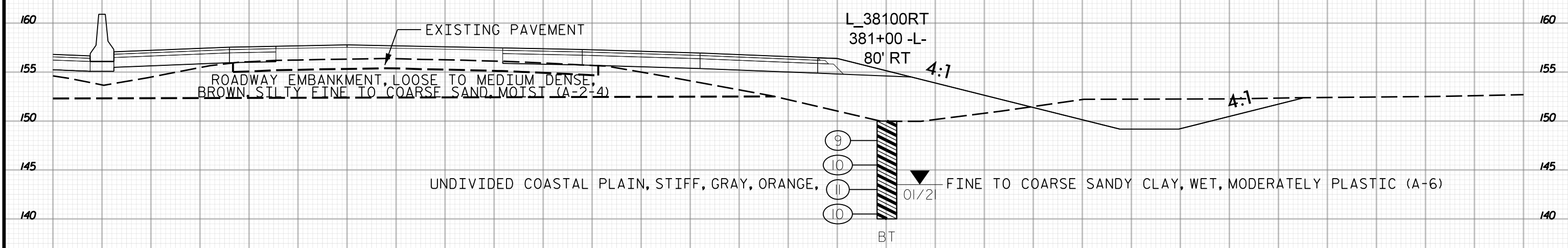

381 + 00

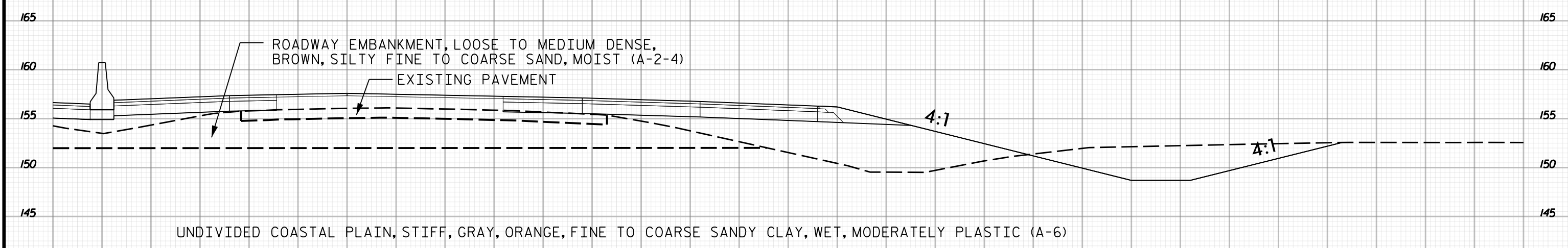

380 + 50  
2 OF 2

-L-

5 0 5 10 15 20 25 30 35 40 45 50 55 60 65 70 75 80 85 90 95 100 105 110 115 120 125 130 135 140 145

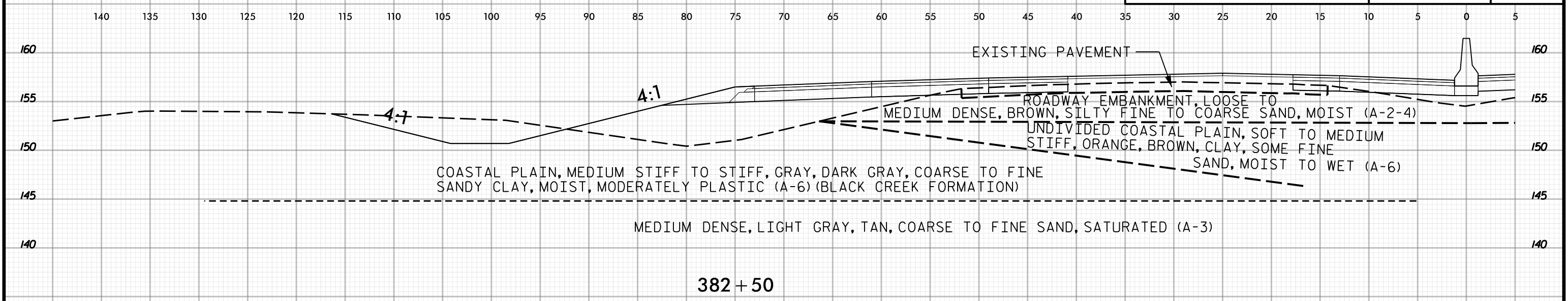

382 + 50

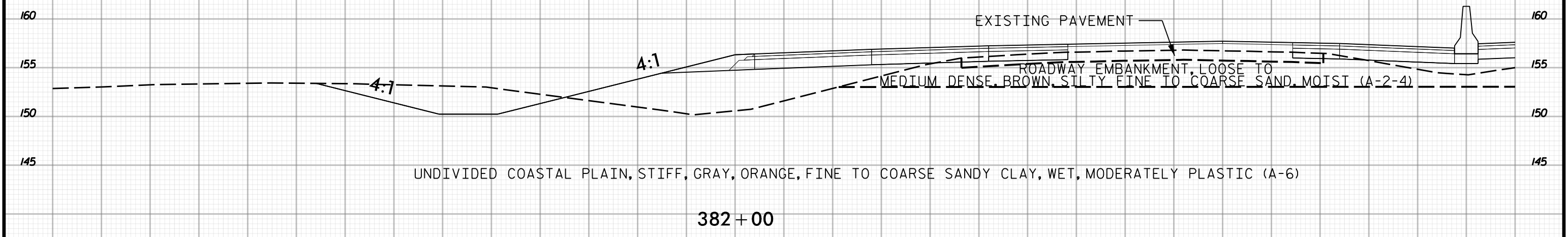

382 + 00

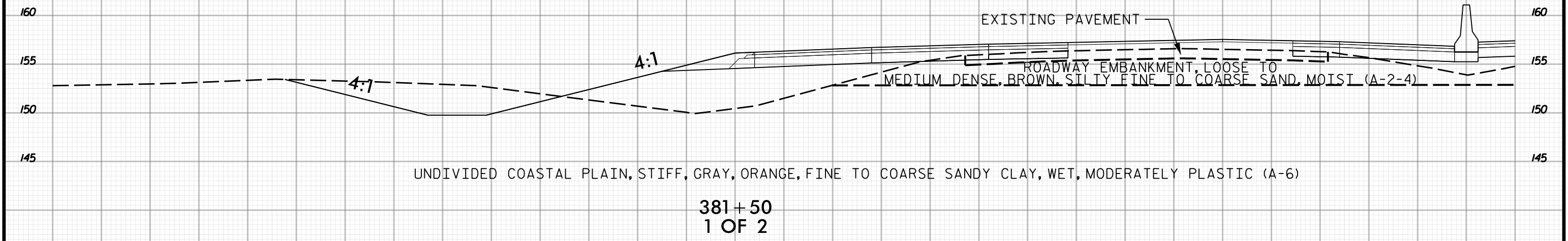

381 + 50  
1 OF 2

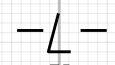

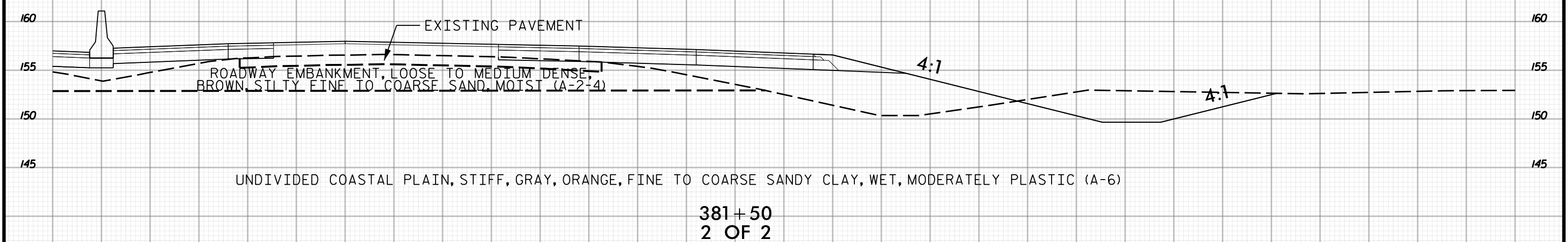
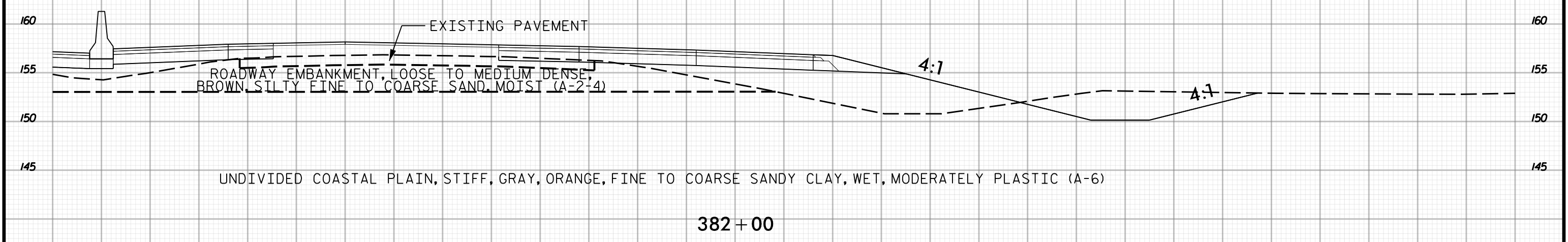
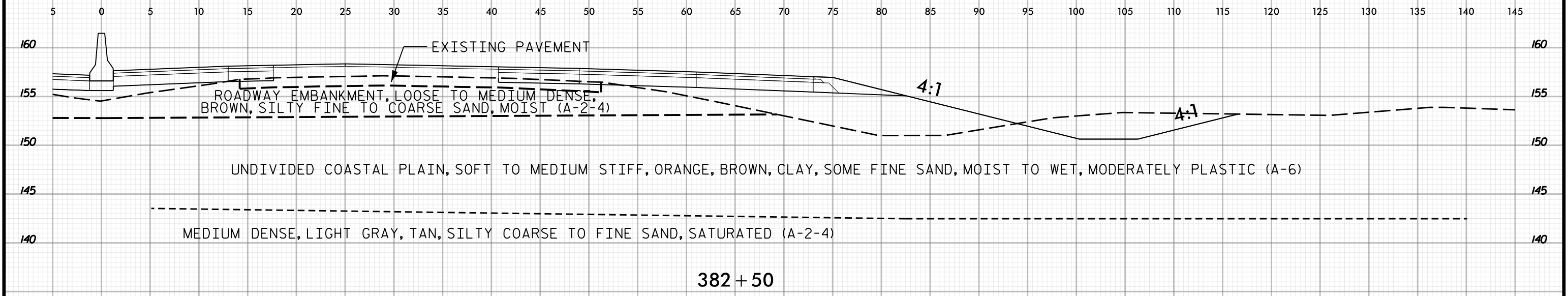

2 OF 2

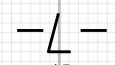



140 135 130 125 120 115 110 105 100 95 90 85 80 75 70 65 60 55 50 45 40 35 30 25 20 15 10 5 0 5

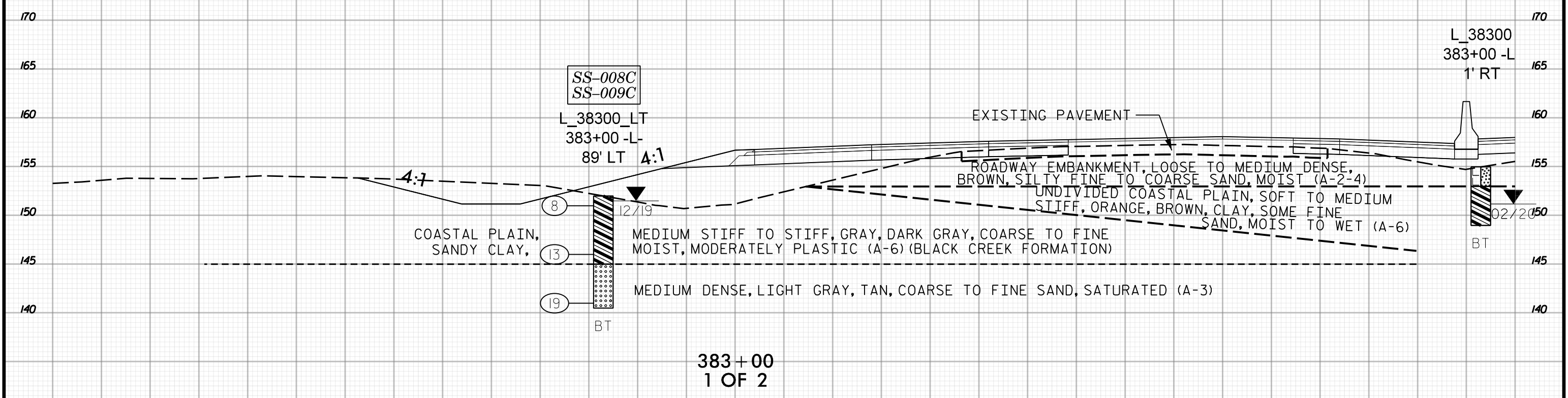
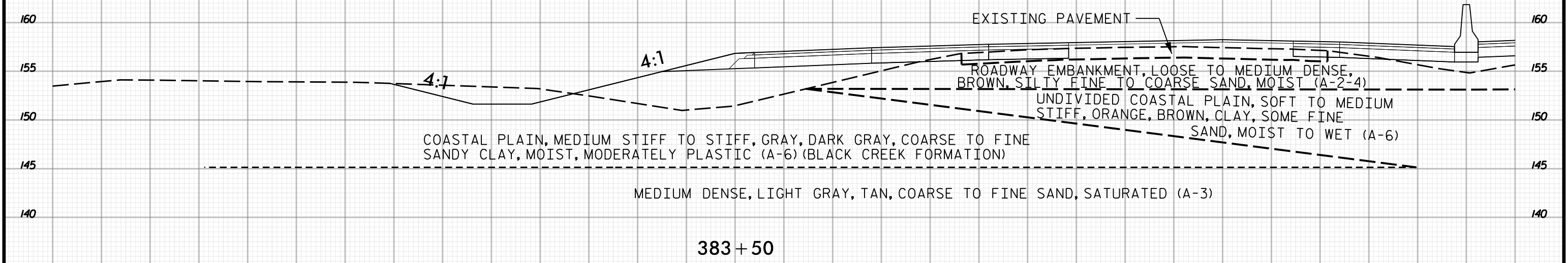

140 135 130 125 120 115 110 105 100 95 90 85 80 75 70 65 60 55 50 45 40 35 30 25 20 15 10 5 0 5



5 0 5 10 15 20 25 30 35 40 45 50 55 60 65 70 75 80 85 90 95 100 105 110 115 120 125 130 135 140 145

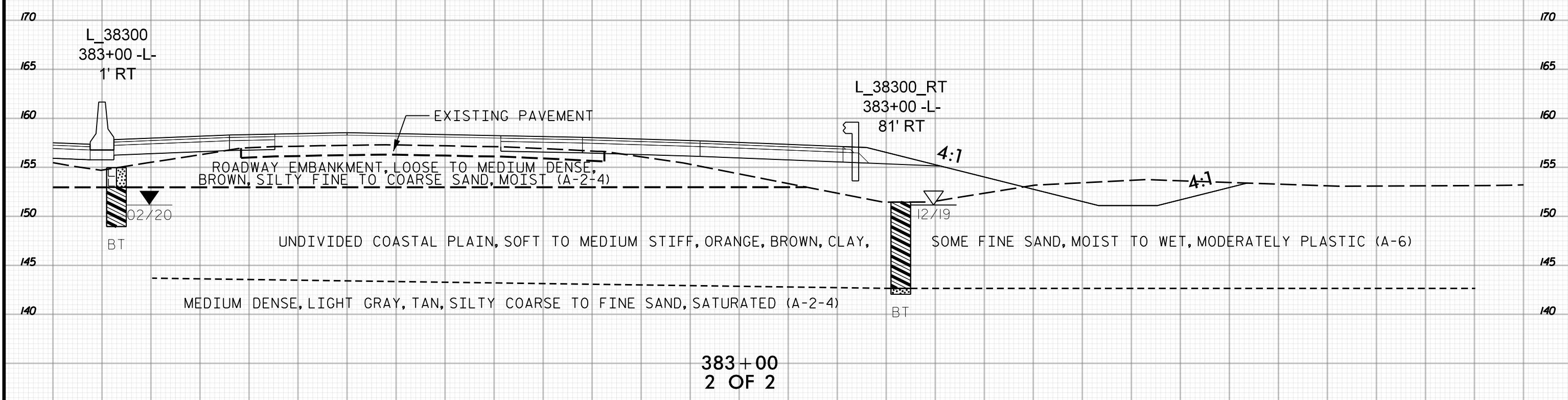
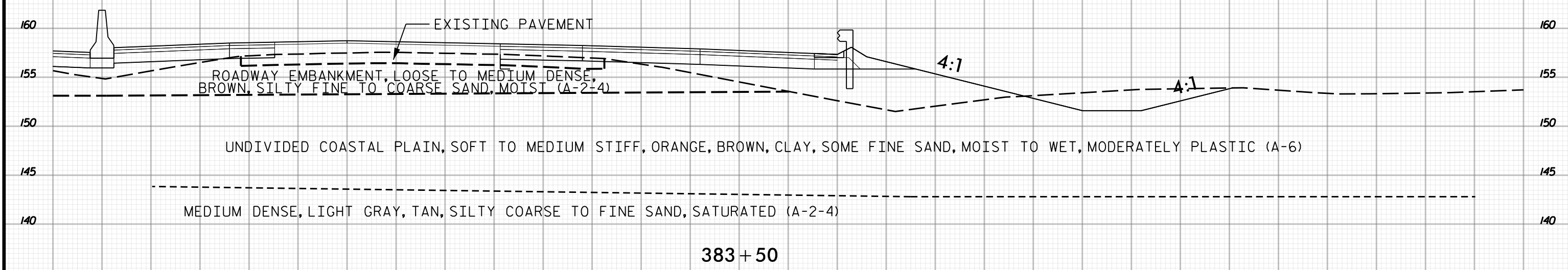

5 0 5 10 15 20 25 30 35 40 45 50 55 60 65 70 75 80 85 90 95 100 105 110 115 120 125 130 135 140 145





140 135 130 125 120 115 110 105 100 95 90 85 80 75 70 65 60 55 50 45 40 35 30 25 20 15 10 5 0 5

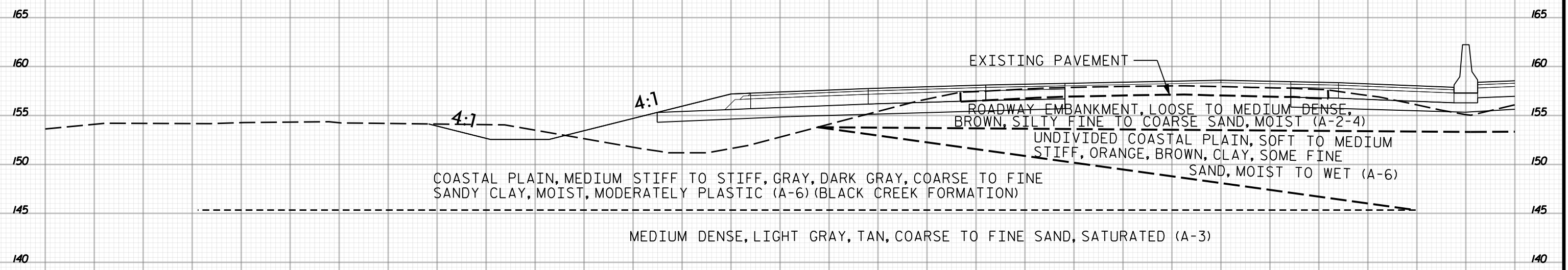

384+50

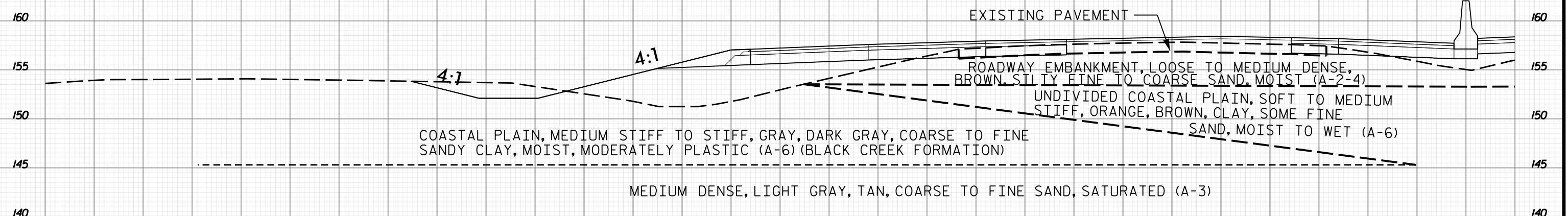

384+00  
1 OF 2

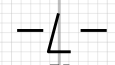

140 135 130 125 120 115 110 105 100 95 90 85 80 75 70 65 60 55 50 45 40 35 30 25 20 15 10 5 0 5



5 0 5 10 15 20 25 30 35 40 45 50 55 60 65 70 75 80 85 90 95 100 105 110 115 120 125 130 135 140 145

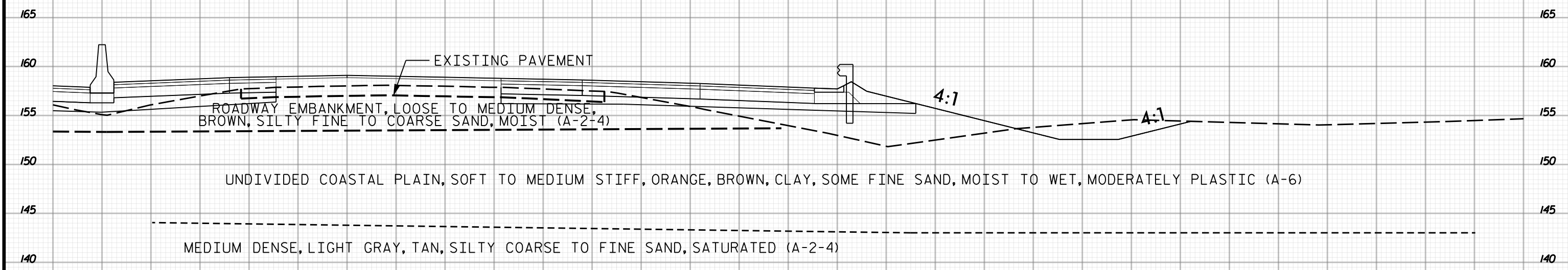

**384+50**

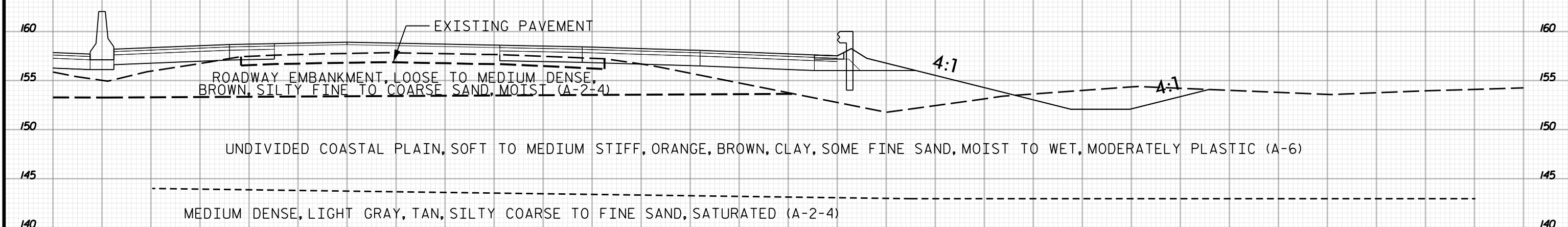

**384+00**  
**2 OF 2**

5 0 5 10 15 20 25 30 35 40 45 50 55 60 65 70 75 80 85 90 95 100 105 110 115 120 125 130 135 140 145



140 135 130 125 120 115 110 105 100 95 90 85 80 75 70 65 60 55 50 45 40 35 30 25 20 15 10 5 0 5

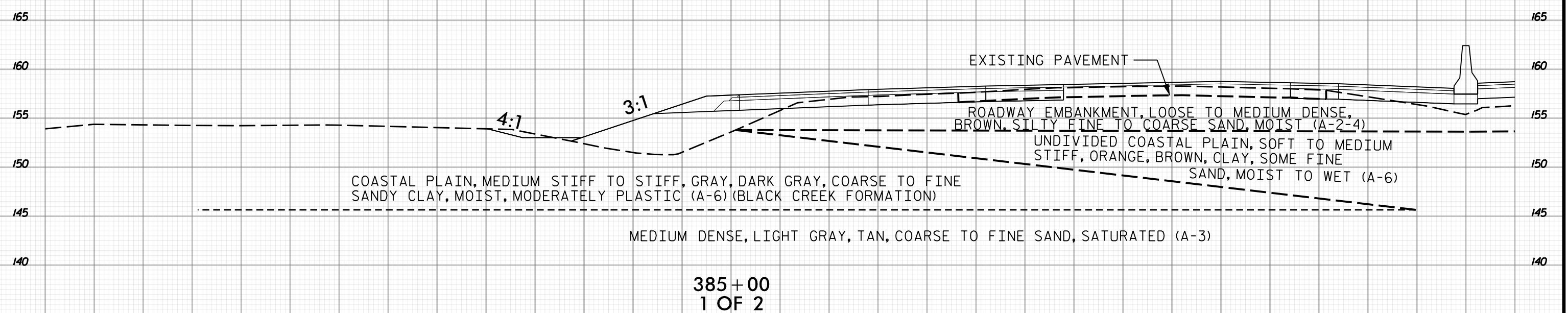
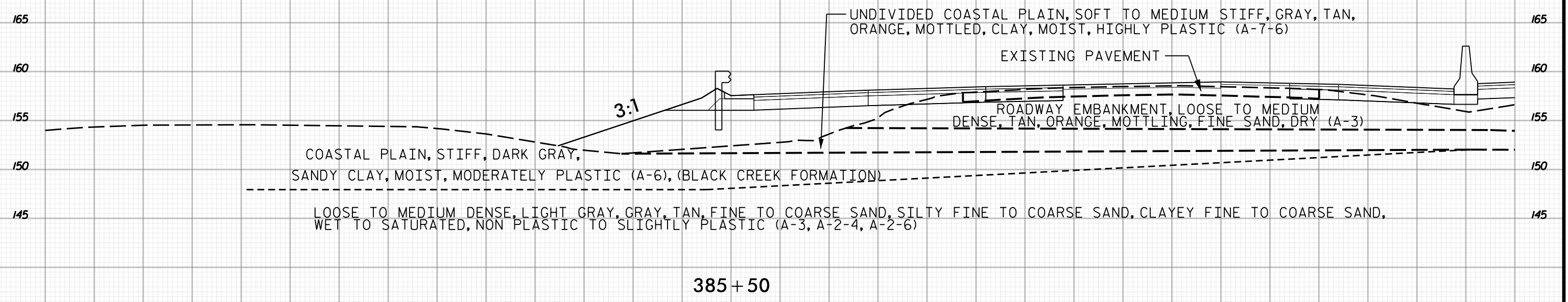

140 135 130 125 120 115 110 105 100 95 90 85 80 75 70 65 60 55 50 45 40 35 30 25 20 15 10 5 0 5

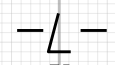



5 0 5 10 15 20 25 30 35 40 45 50 55 60 65 70 75 80 85 90 95 100 105 110 115 120 125 130 135 140 145

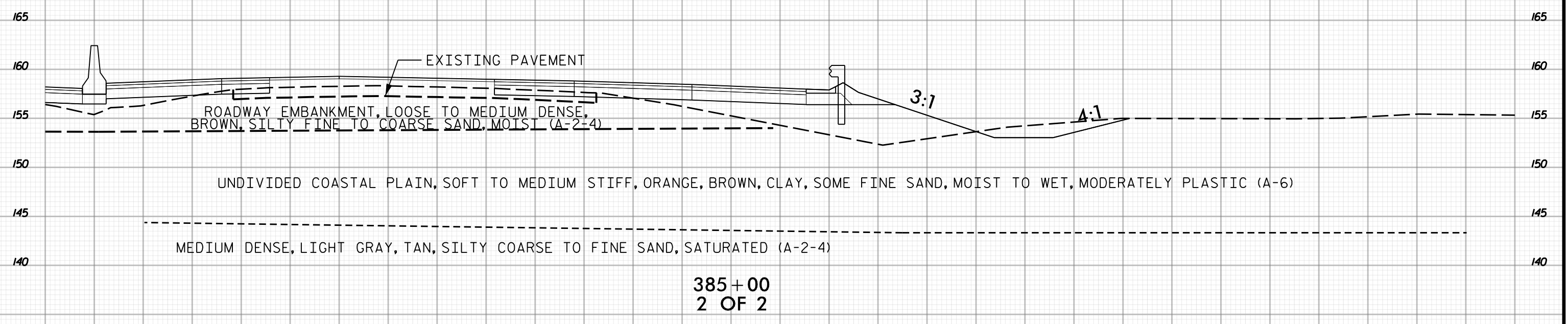
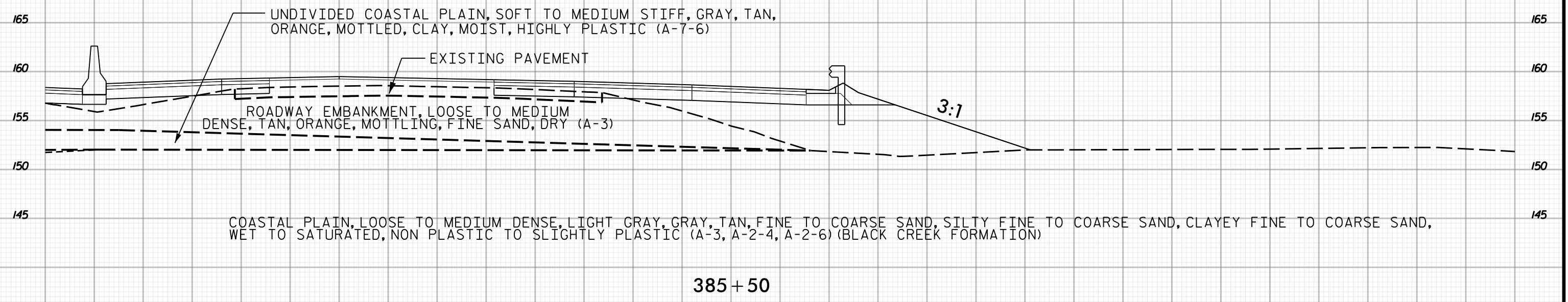

5 0 5 10 15 20 25 30 35 40 45 50 55 60 65 70 75 80 85 90 95 100 105 110 115 120 125 130 135 140 145



140 135 130 125 120 115 110 105 100 95 90 85 80 75 70 65 60 55 50 45 40 35 30 25 20 15 10 5 0 5

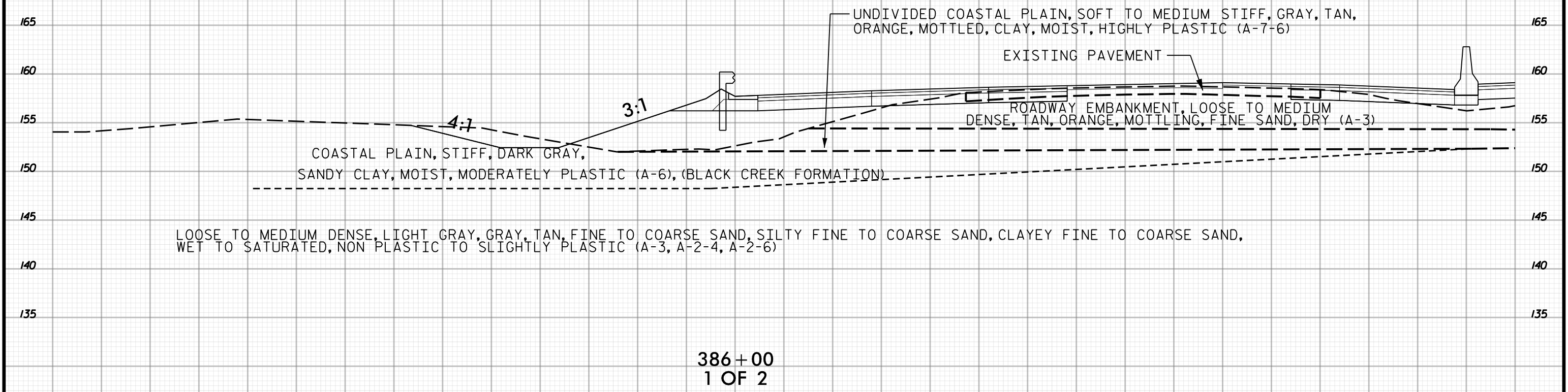
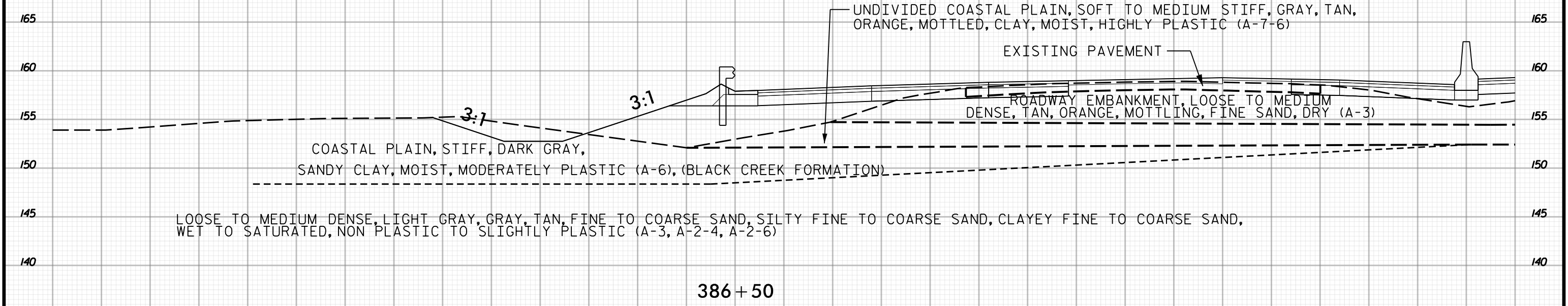

140 135 130 125 120 115 110 105 100 95 90 85 80 75 70 65 60 55 50 45 40 35 30 25 20 15 10 5 0 5



5 0 5 10 15 20 25 30 35 40 45 50 55 60 65 70 75 80 85 90 95 100 105 110 115 120 125 130 135 140 145

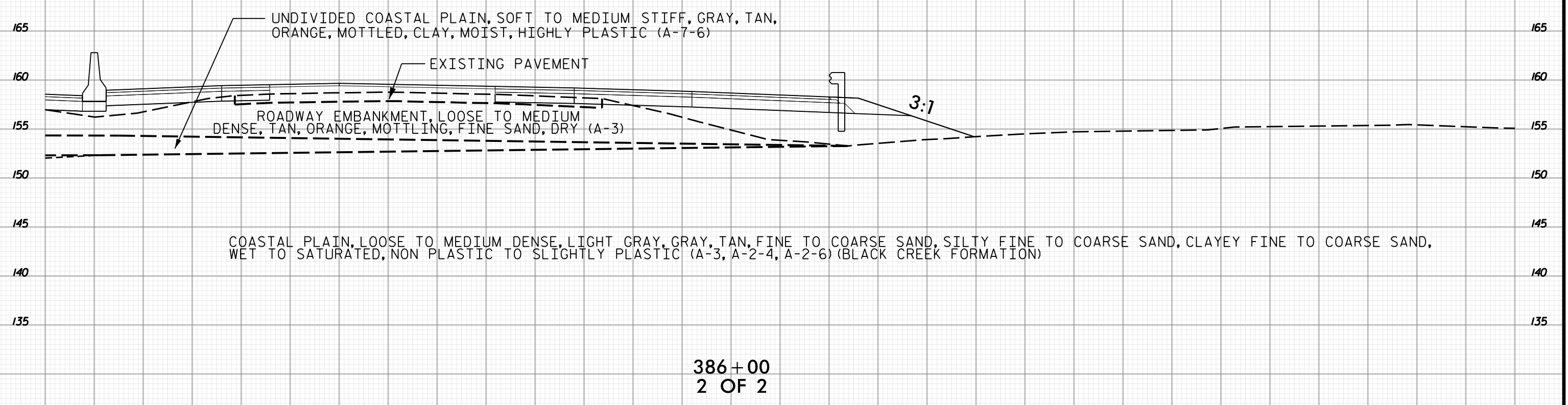
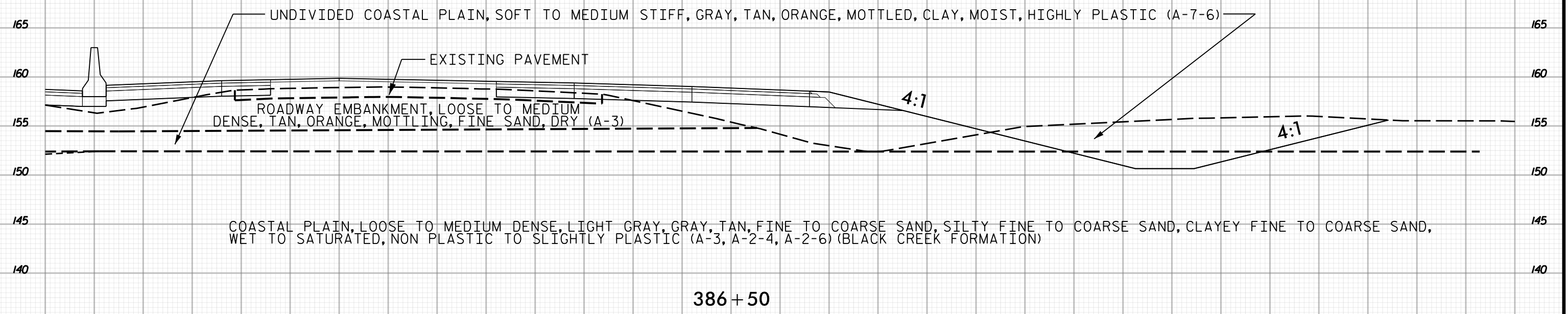

5 0 5 10 15 20 25 30 35 40 45 50 55 60 65 70 75 80 85 90 95 100 105 110 115 120 125 130 135 140 145



140 135 130 125 120 115 110 105 100 95 90 85 80 75 70 65 60 55 50 45 40 35 30 25 20 15 10 5 0 5

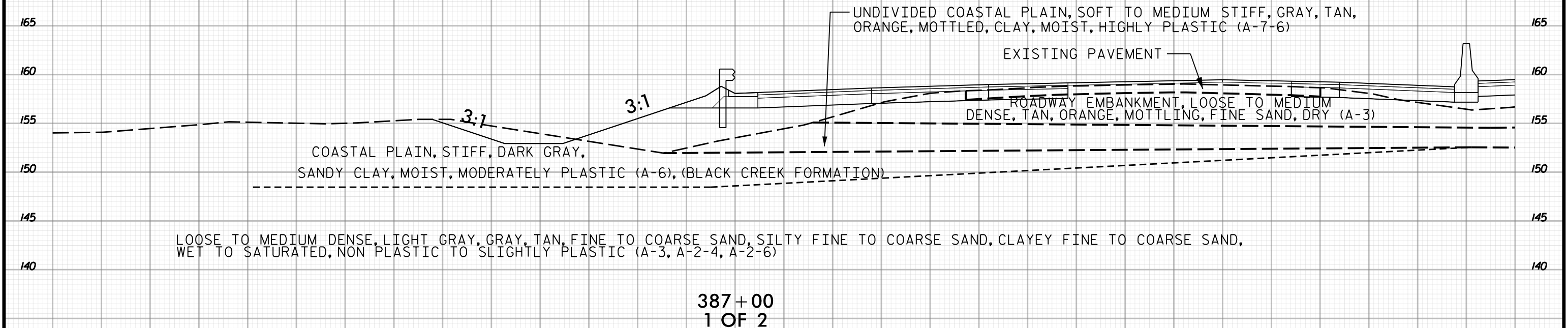
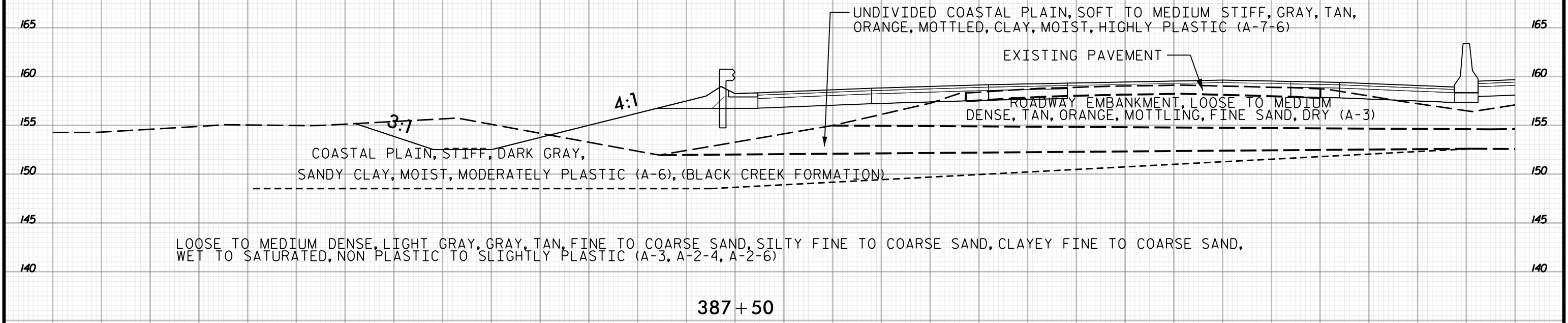

140 135 130 125 120 115 110 105 100 95 90 85 80 75 70 65 60 55 50 45 40 35 30 25 20 15 10 5 0 5

1 OF 2

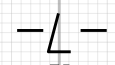



5 0 5 10 15 20 25 30 35 40 45 50 55 60 65 70 75 80 85 90 95 100 105 110 115 120 125 130 135 140 145

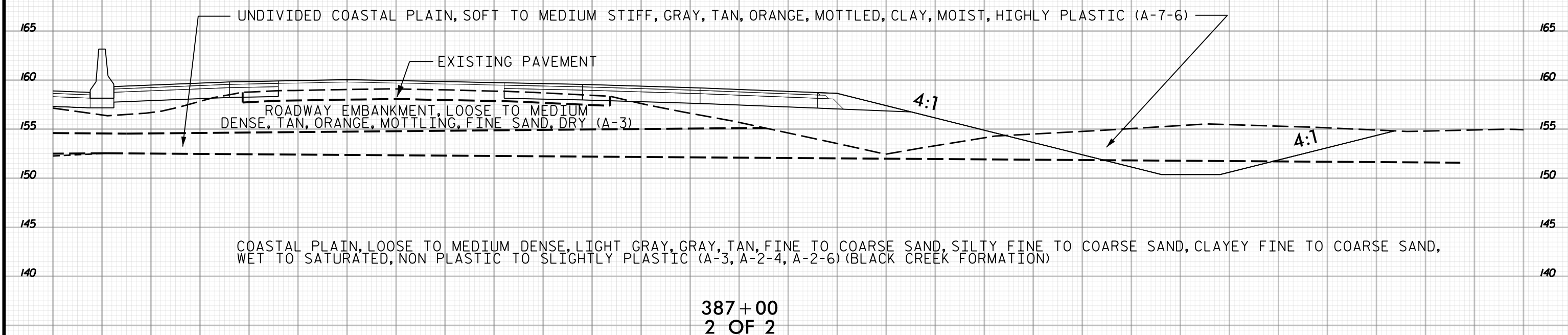
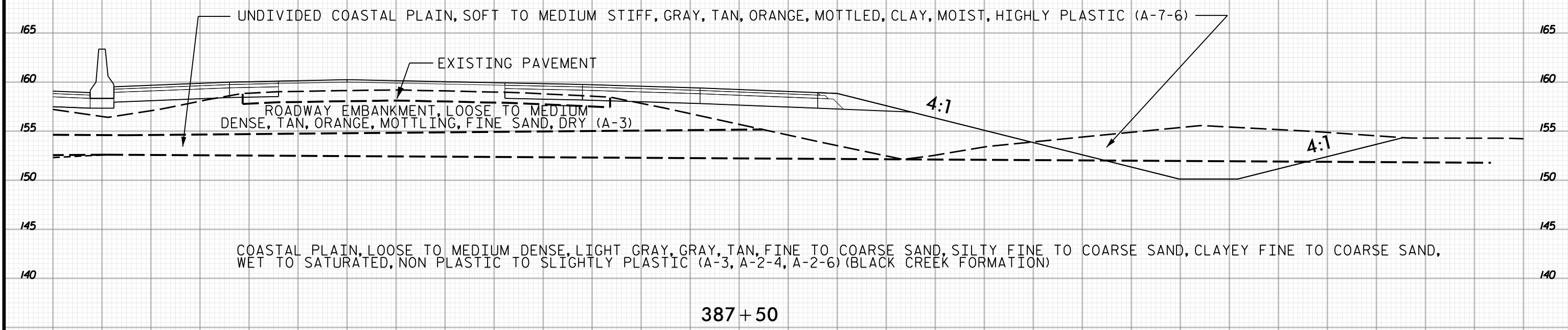

5 0 5 10 15 20 25 30 35 40 45 50 55 60 65 70 75 80 85 90 95 100 105 110 115 120 125 130 135 140 145



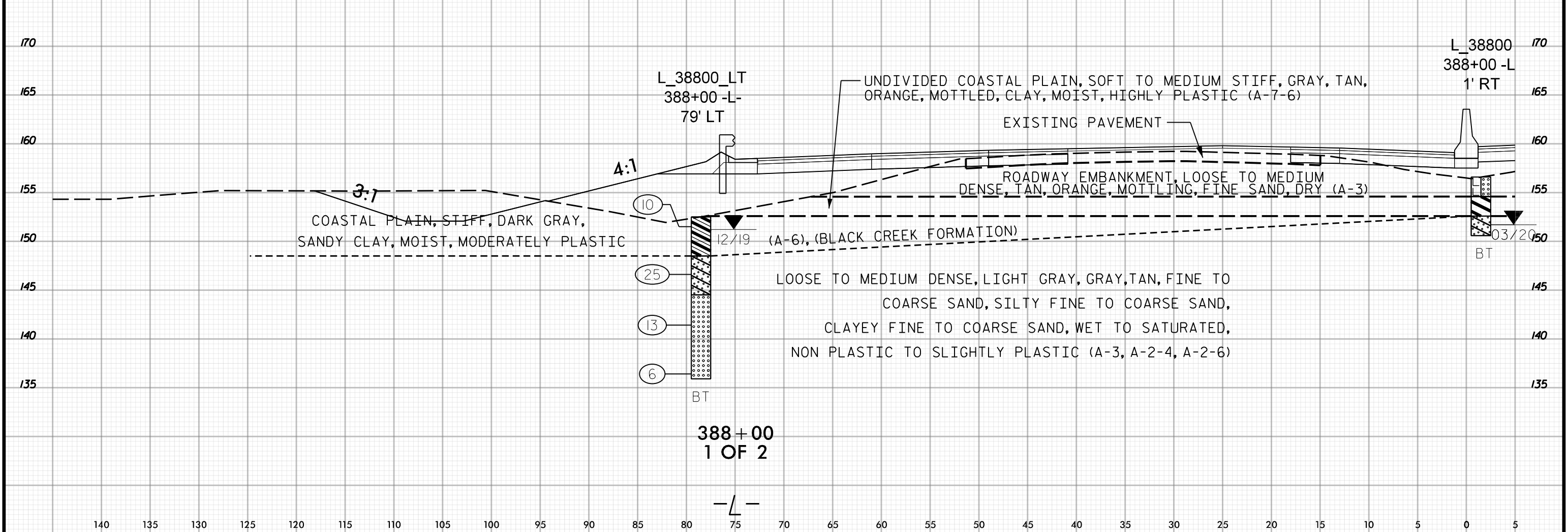
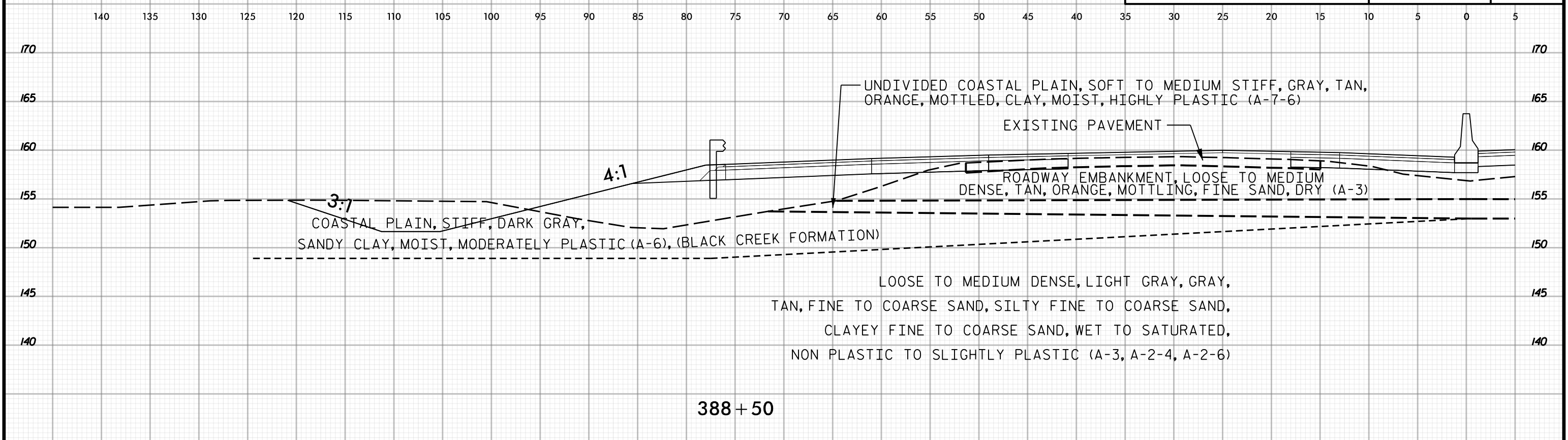
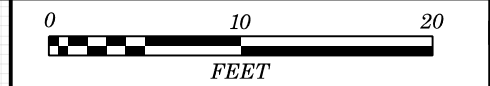

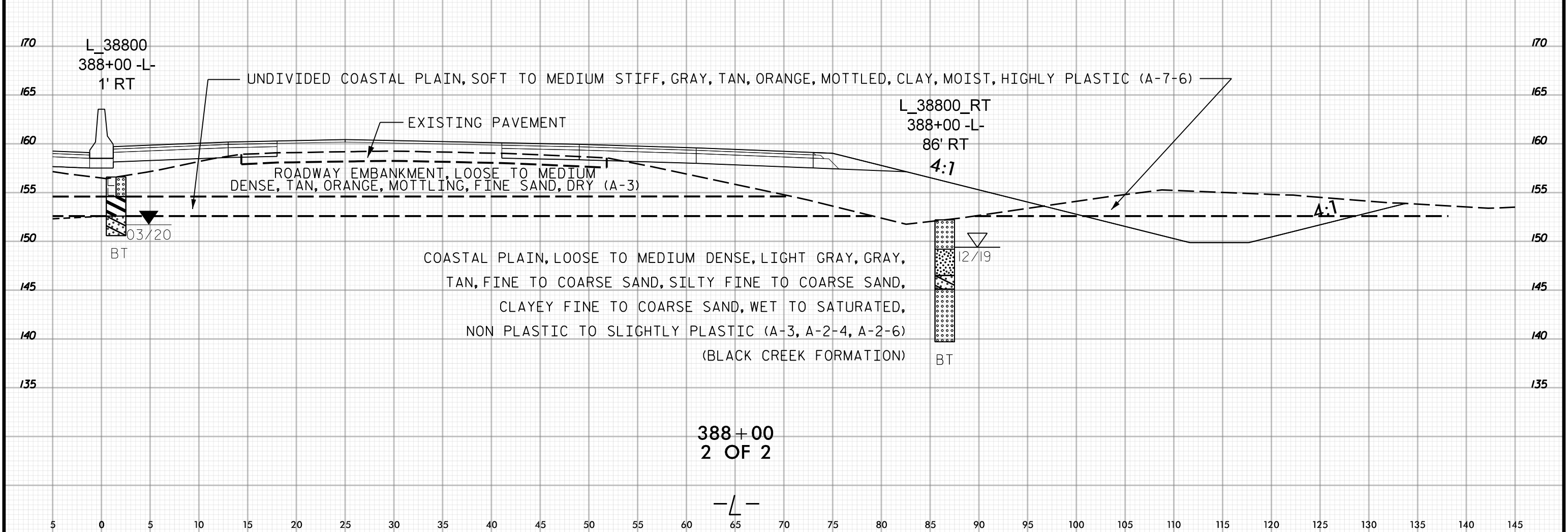
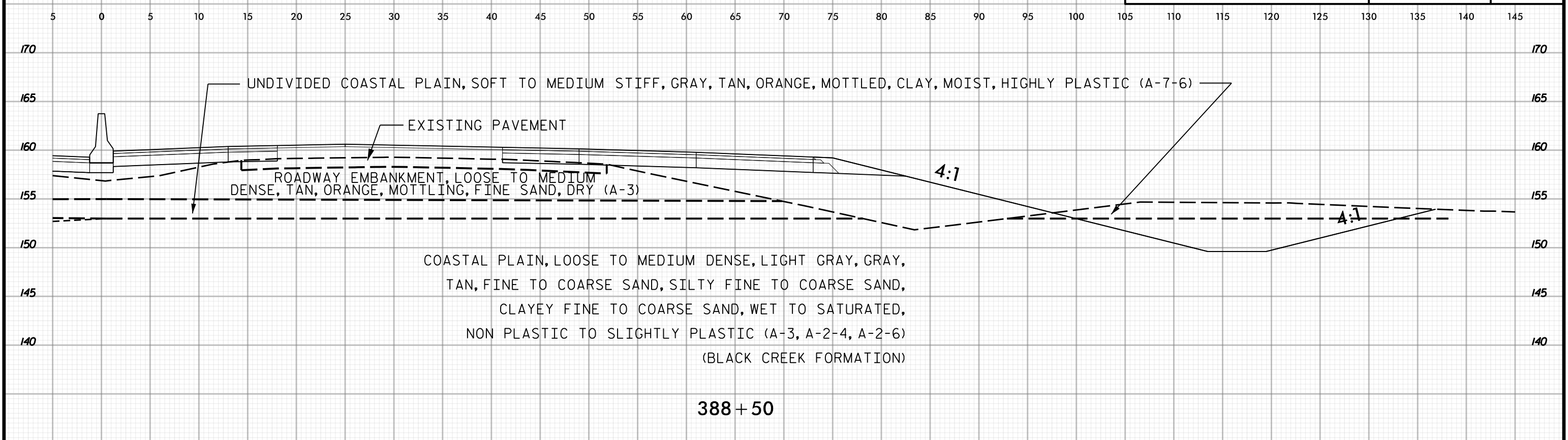



140 135 130 125 120 115 110 105 100 95 90 85 80 75 70 65 60 55 50 45 40 35 30 25 20 15 10 5 0 5

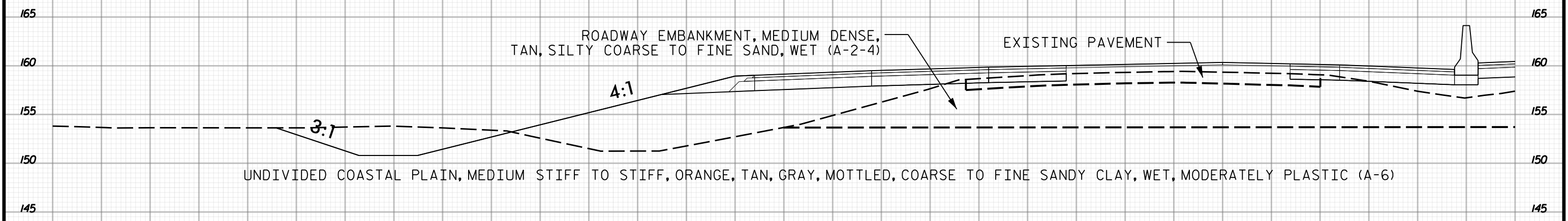

389+50

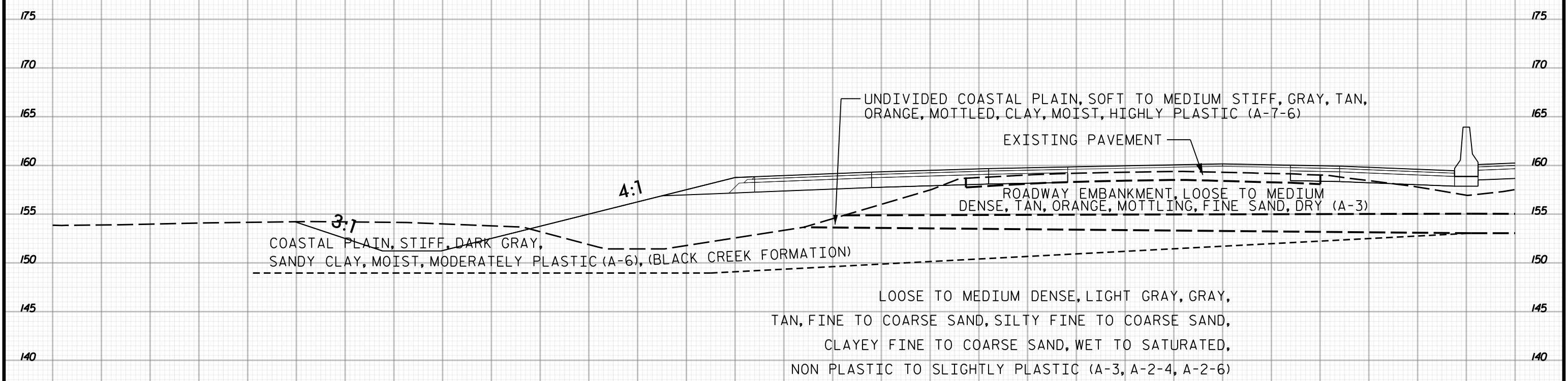

389+00  
1 OF 2

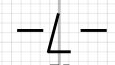

140 135 130 125 120 115 110 105 100 95 90 85 80 75 70 65 60 55 50 45 40 35 30 25 20 15 10 5 0 5



5 0 5 10 15 20 25 30 35 40 45 50 55 60 65 70 75 80 85 90 95 100 105 110 115 120 125 130 135 140 145

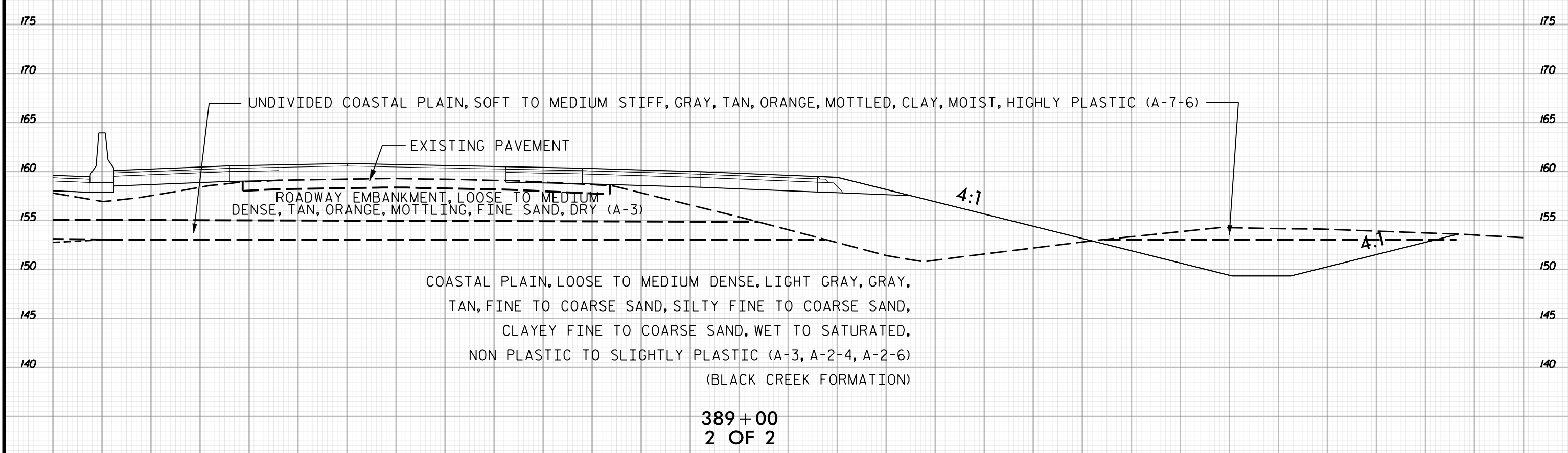
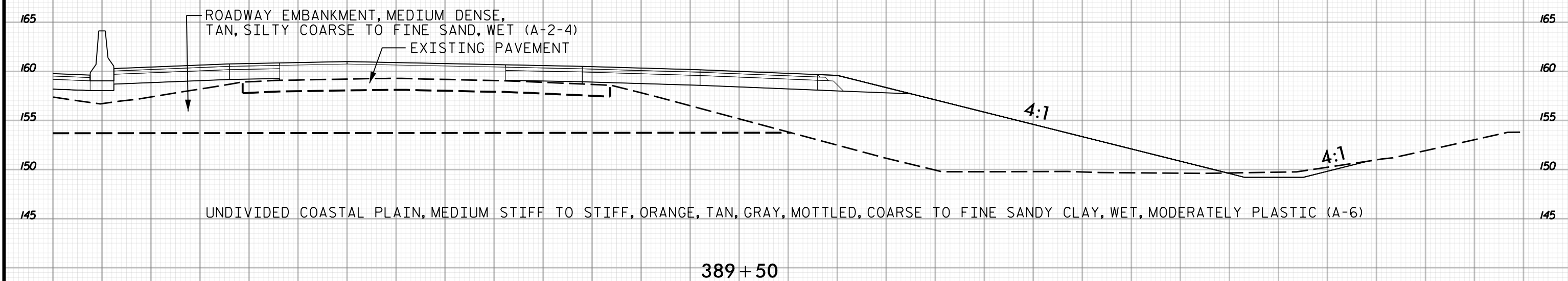

5 0 5 10 15 20 25 30 35 40 45 50 55 60 65 70 75 80 85 90 95 100 105 110 115 120 125 130 135 140 145

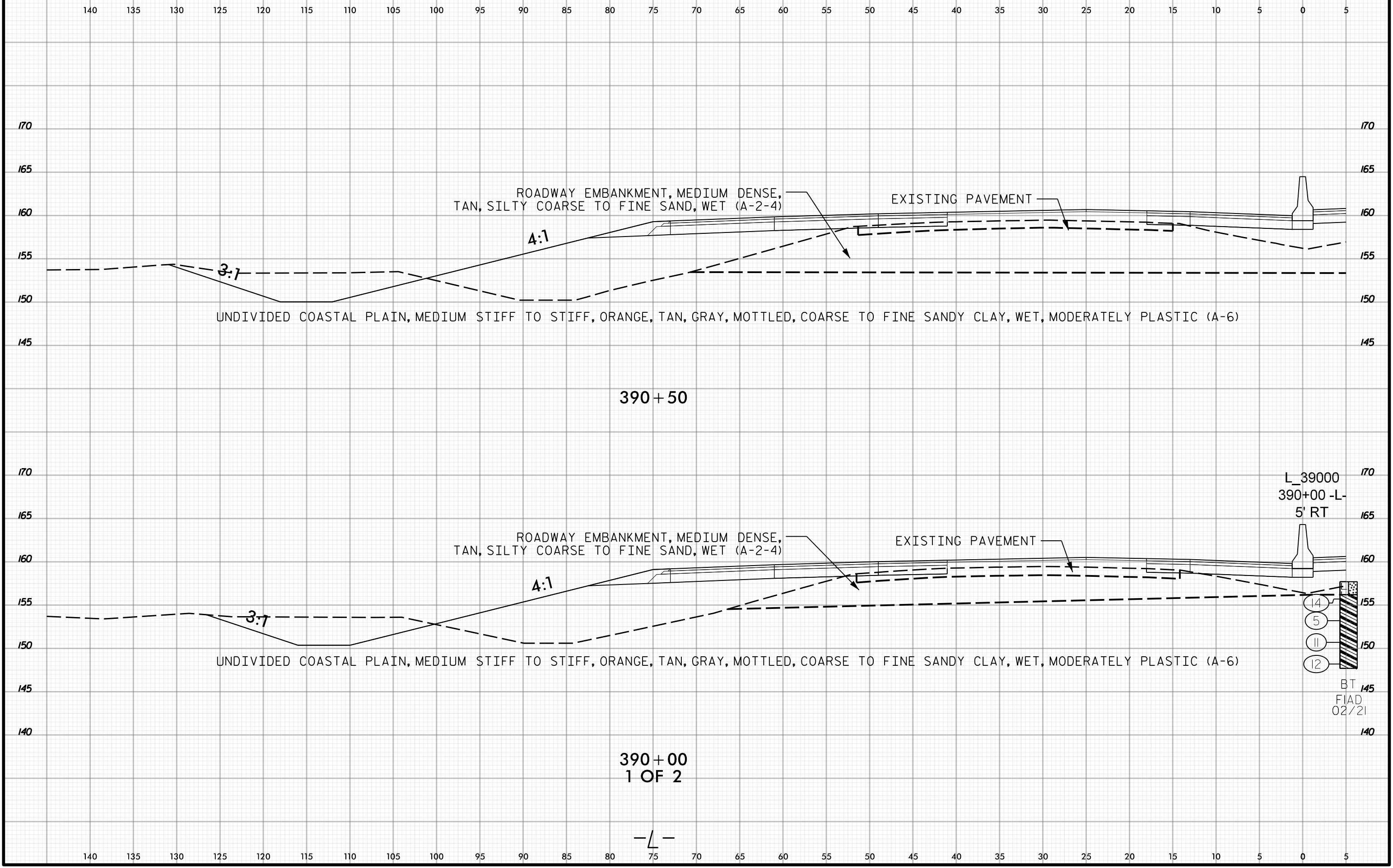
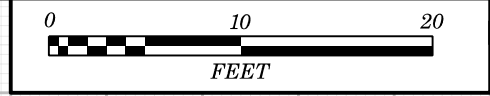

390+50

390+00  
1 OF 2

L\_39000  
390+00 -L-  
5' RT

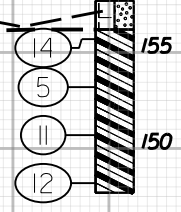

BT  
FIAD  
02/21

-L-

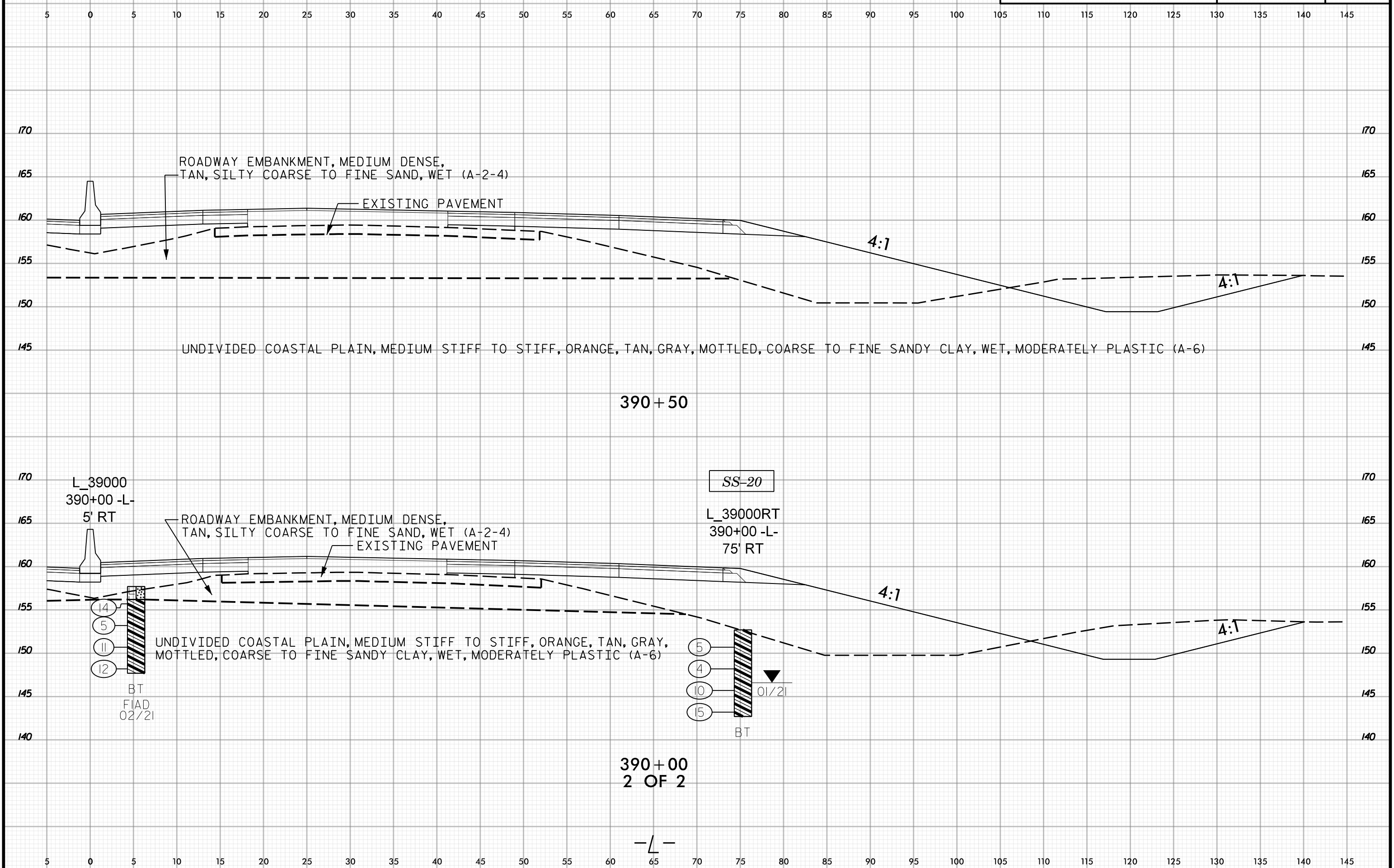

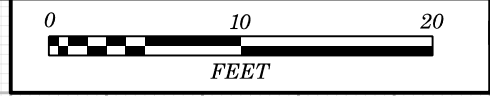

140 135 130 125 120 115 110 105 100 95 90 85 80 75 70 65 60 55 50 45 40 35 30 25 20 15 10 5 0 5

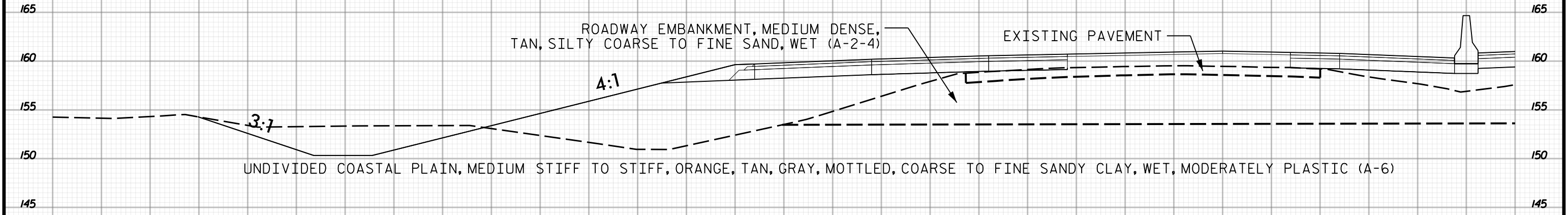

391+50

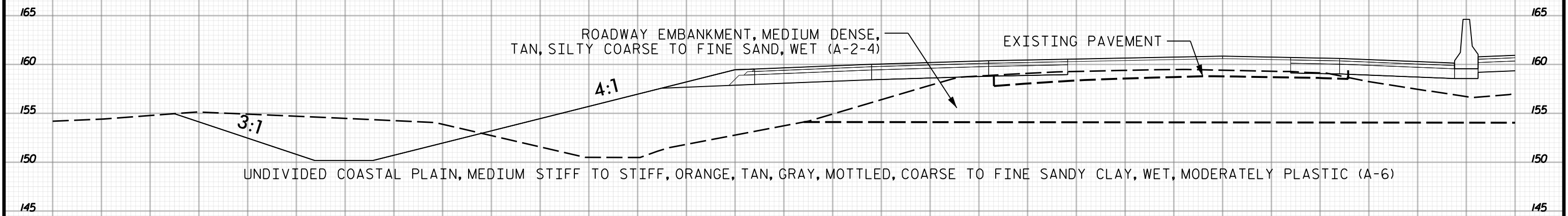

391+00  
1 OF 2

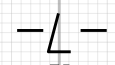

140 135 130 125 120 115 110 105 100 95 90 85 80 75 70 65 60 55 50 45 40 35 30 25 20 15 10 5 0 5



5 0 5 10 15 20 25 30 35 40 45 50 55 60 65 70 75 80 85 90 95 100 105 110 115 120 125 130 135 140 145

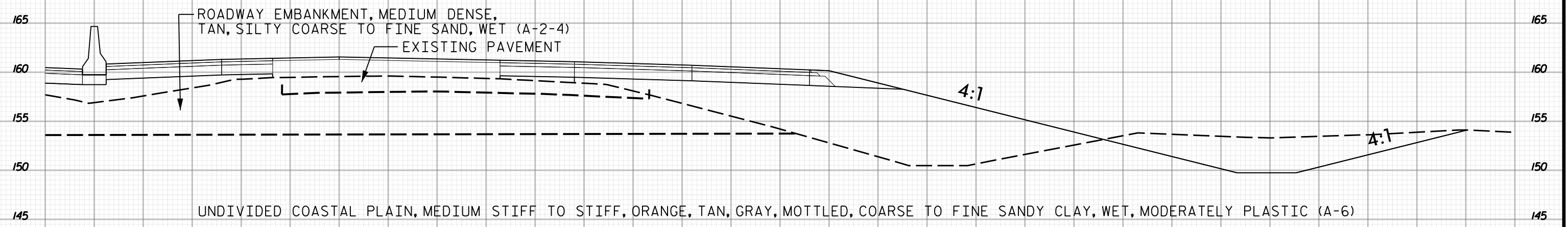

391+50



391+00  
2 OF 2

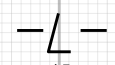

5 0 5 10 15 20 25 30 35 40 45 50 55 60 65 70 75 80 85 90 95 100 105 110 115 120 125 130 135 140 145



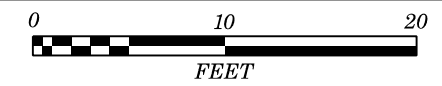

140 135 130 125 120 115 110 105 100 95 90 85 80 75 70 65 60 55 50 45 40 35 30 25 20 15 10 5 0 5

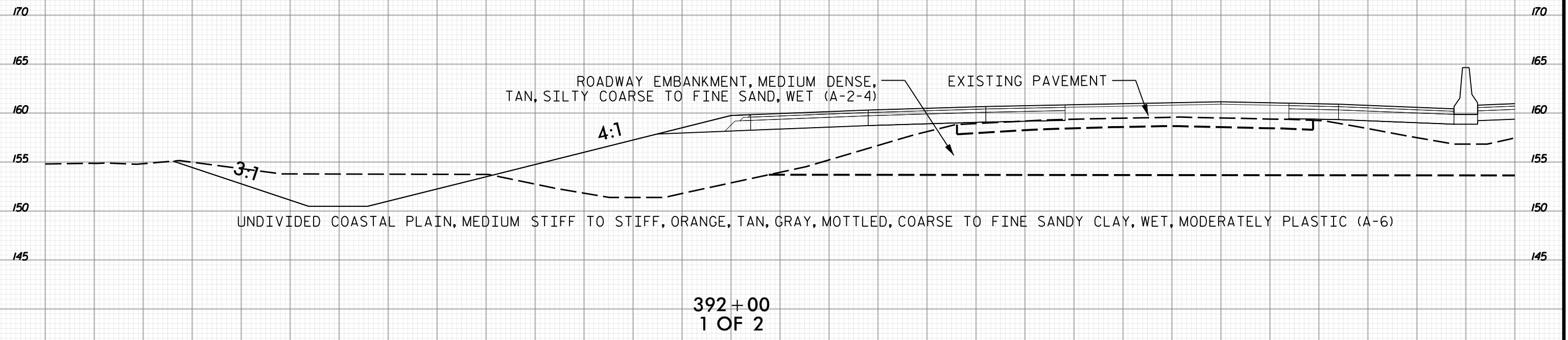
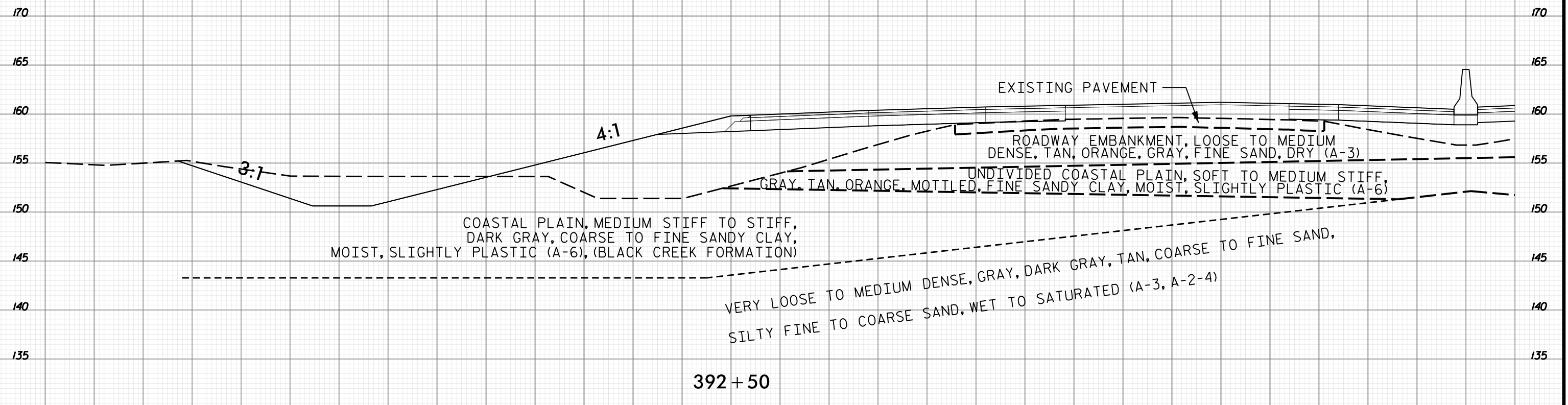

140 135 130 125 120 115 110 105 100 95 90 85 80 75 70 65 60 55 50 45 40 35 30 25 20 15 10 5 0 5

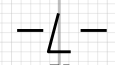



5 0 5 10 15 20 25 30 35 40 45 50 55 60 65 70 75 80 85 90 95 100 105 110 115 120 125 130 135 140 145

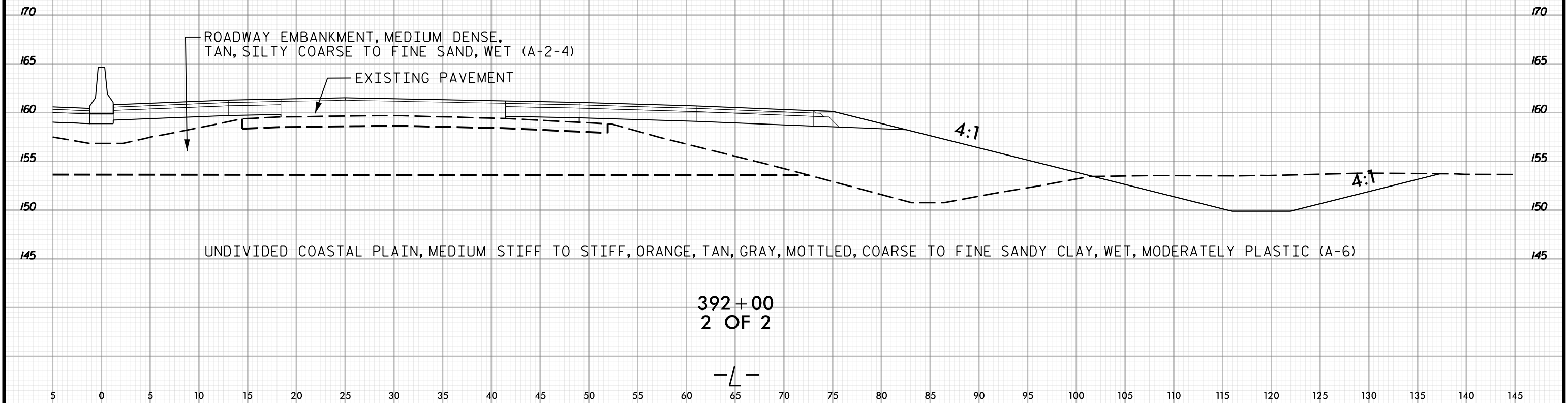
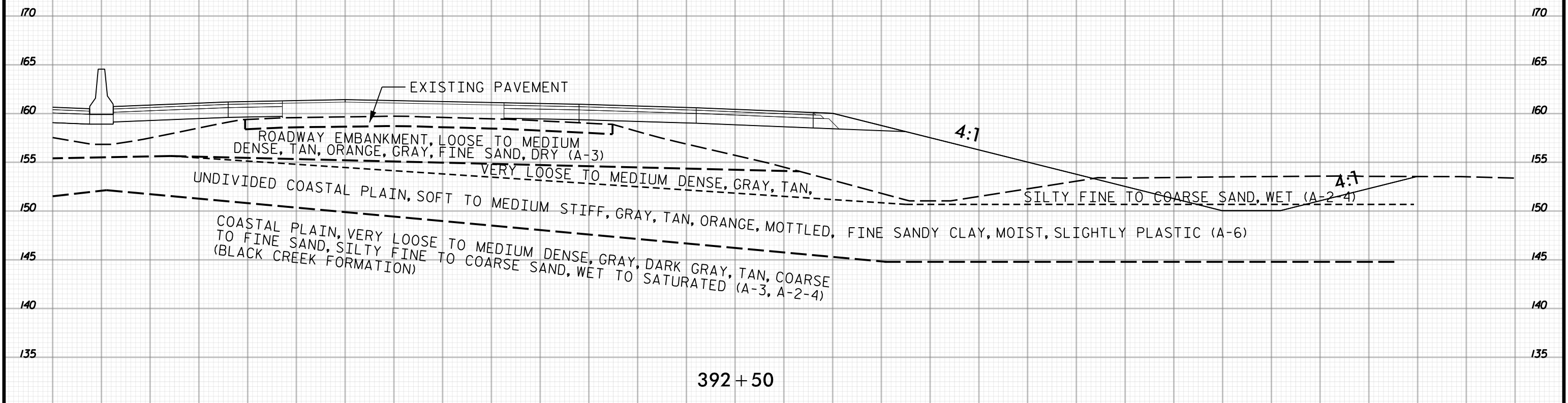

5 0 5 10 15 20 25 30 35 40 45 50 55 60 65 70 75 80 85 90 95 100 105 110 115 120 125 130 135 140 145

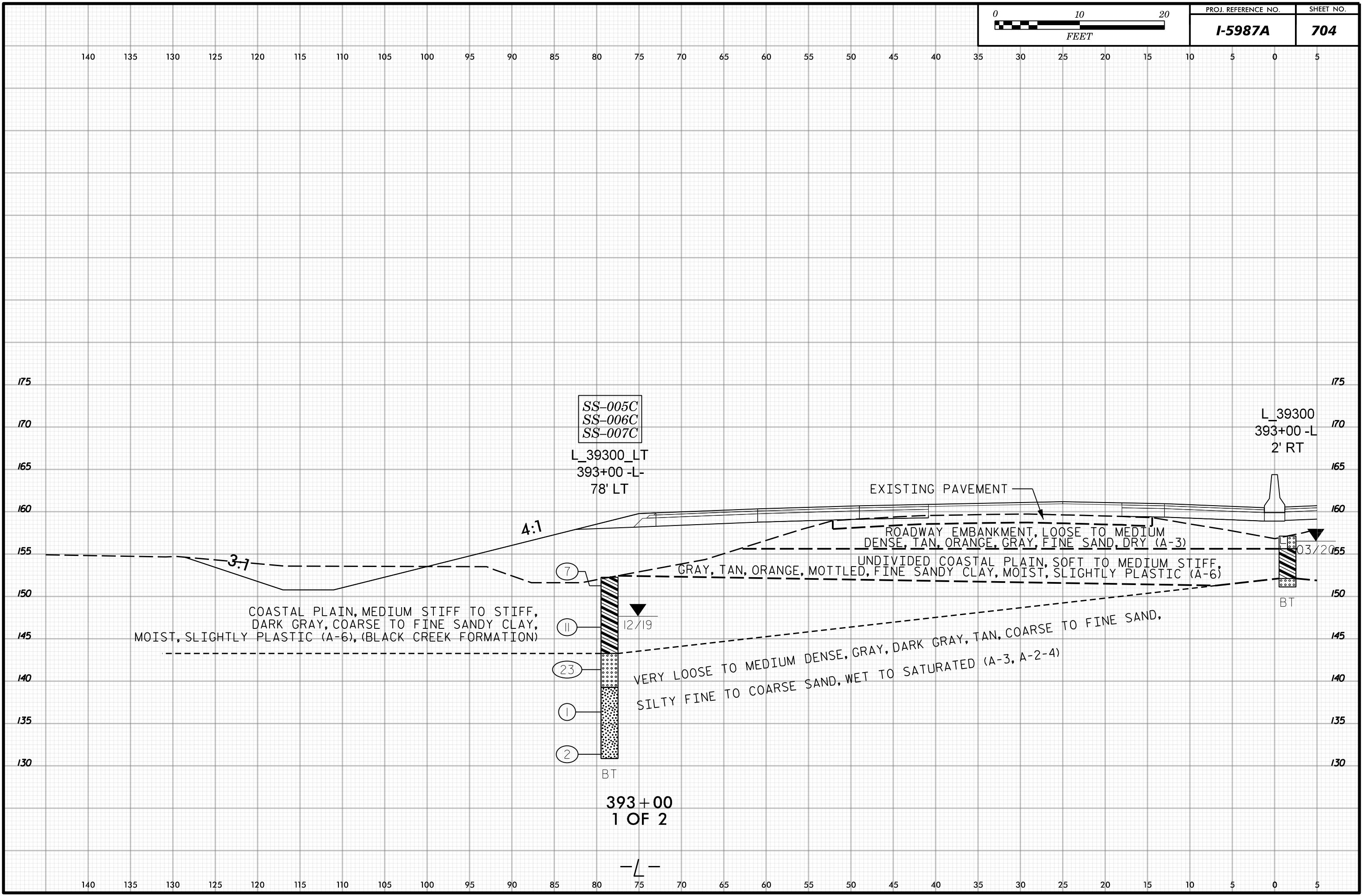

SS-005C  
 SS-006C  
 SS-007C  
 L\_39300\_LT  
 393+00 -L-  
 78' LT

L\_39300  
 393+00 -L  
 2' RT

EXISTING PAVEMENT

ROADWAY EMBANKMENT, LOOSE TO MEDIUM  
 DENSE, TAN, ORANGE, GRAY, FINE SAND, DRY (A-3)

UNDIVIDED COASTAL PLAIN, SOFT TO MEDIUM STIFF,  
 GRAY, TAN, ORANGE, MOTTLED, FINE SANDY CLAY, MOIST, SLIGHTLY PLASTIC (A-6)

COASTAL PLAIN, MEDIUM STIFF TO STIFF,  
 DARK GRAY, COARSE TO FINE SANDY CLAY,  
 MOIST, SLIGHTLY PLASTIC (A-6), (BLACK CREEK FORMATION)

VERY LOOSE TO MEDIUM DENSE, GRAY, DARK GRAY, TAN, COARSE TO FINE SAND,  
 SILTY FINE TO COARSE SAND, WET TO SATURATED (A-3, A-2-4)

- (7)
- (11)
- (23)
- (1)
- (2)

12/19

BT

393+00  
 1 OF 2

-L-



5 0 5 10 15 20 25 30 35 40 45 50 55 60 65 70 75 80 85 90 95 100 105 110 115 120 125 130 135 140 145

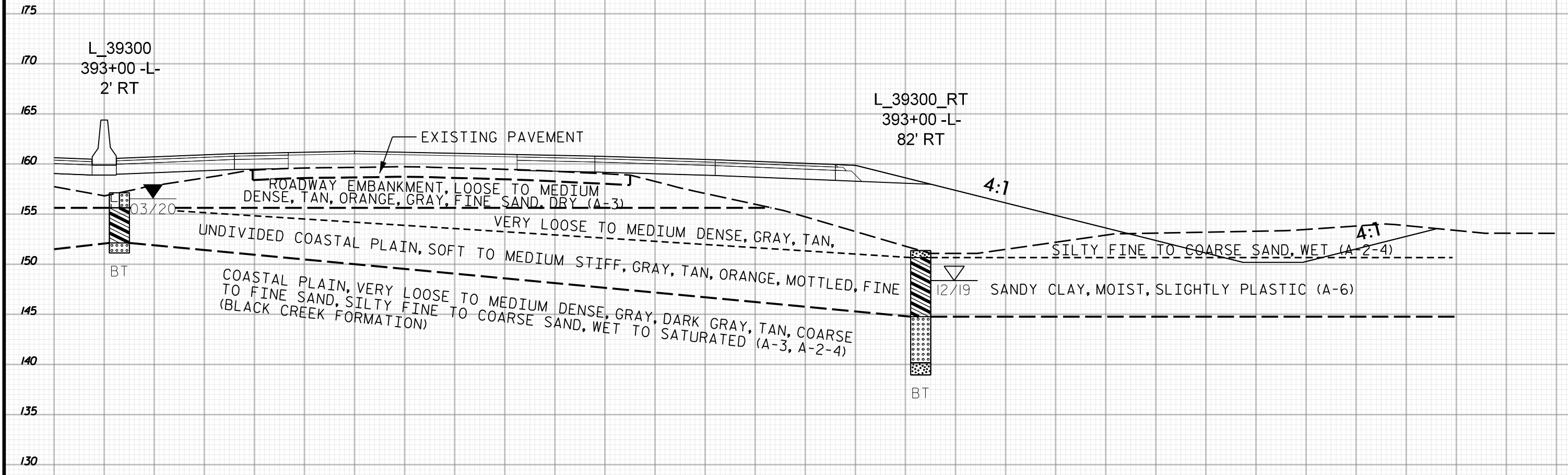

L\_39300  
393+00 -L-  
2' RT

L\_39300\_RT  
393+00 -L-  
82' RT

BT

BT

393+00  
2 OF 2

-L-

5 0 5 10 15 20 25 30 35 40 45 50 55 60 65 70 75 80 85 90 95 100 105 110 115 120 125 130 135 140 145



140 135 130 125 120 115 110 105 100 95 90 85 80 75 70 65 60 55 50 45 40 35 30 25 20 15 10 5 0 5

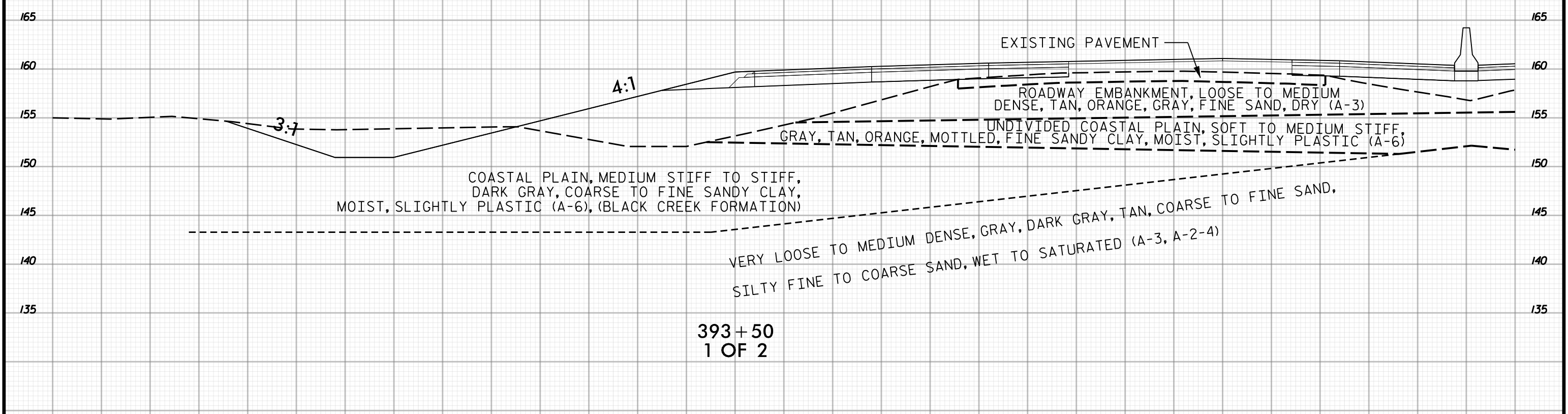
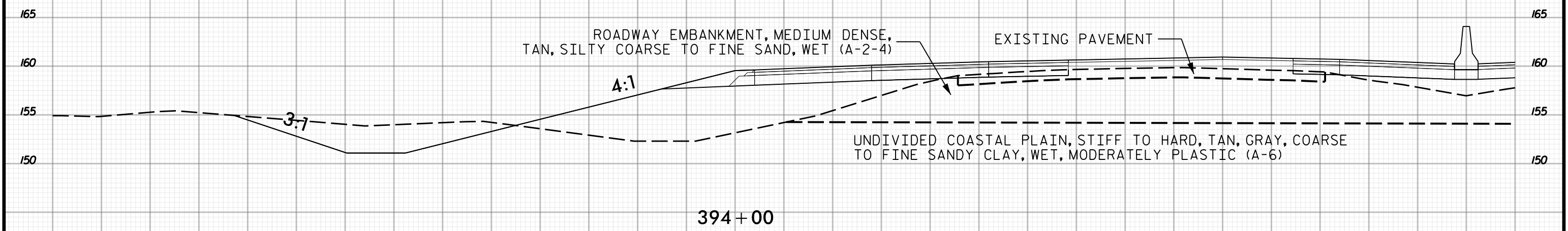

140 135 130 125 120 115 110 105 100 95 90 85 80 75 70 65 60 55 50 45 40 35 30 25 20 15 10 5 0 5



5 0 5 10 15 20 25 30 35 40 45 50 55 60 65 70 75 80 85 90 95 100 105 110 115 120 125 130 135 140 145

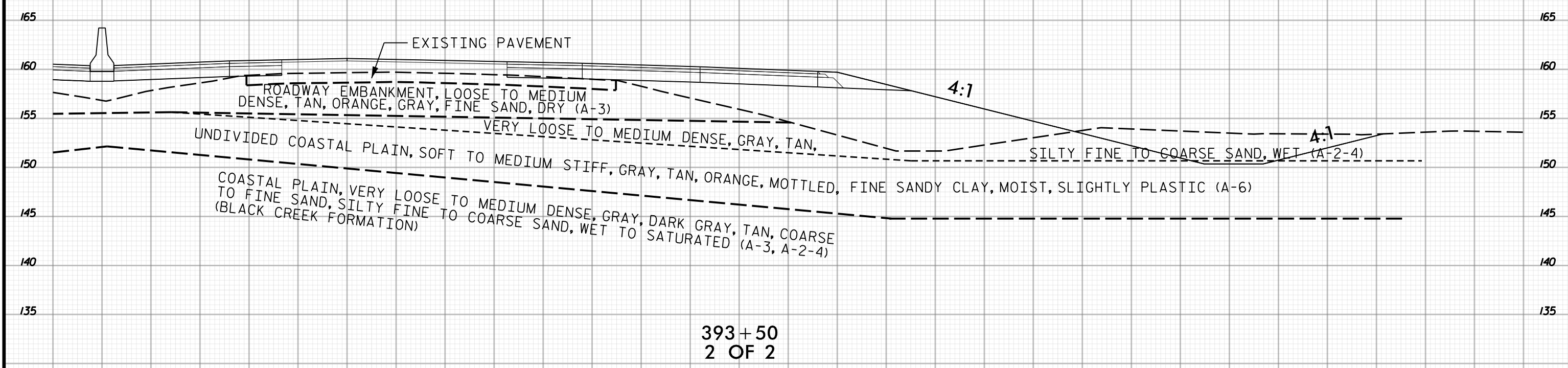
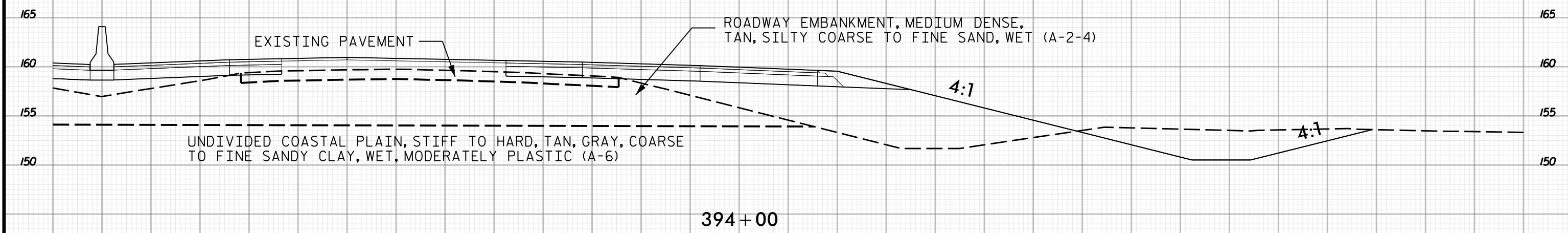

5 0 5 10 15 20 25 30 35 40 45 50 55 60 65 70 75 80 85 90 95 100 105 110 115 120 125 130 135 140 145

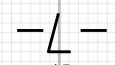

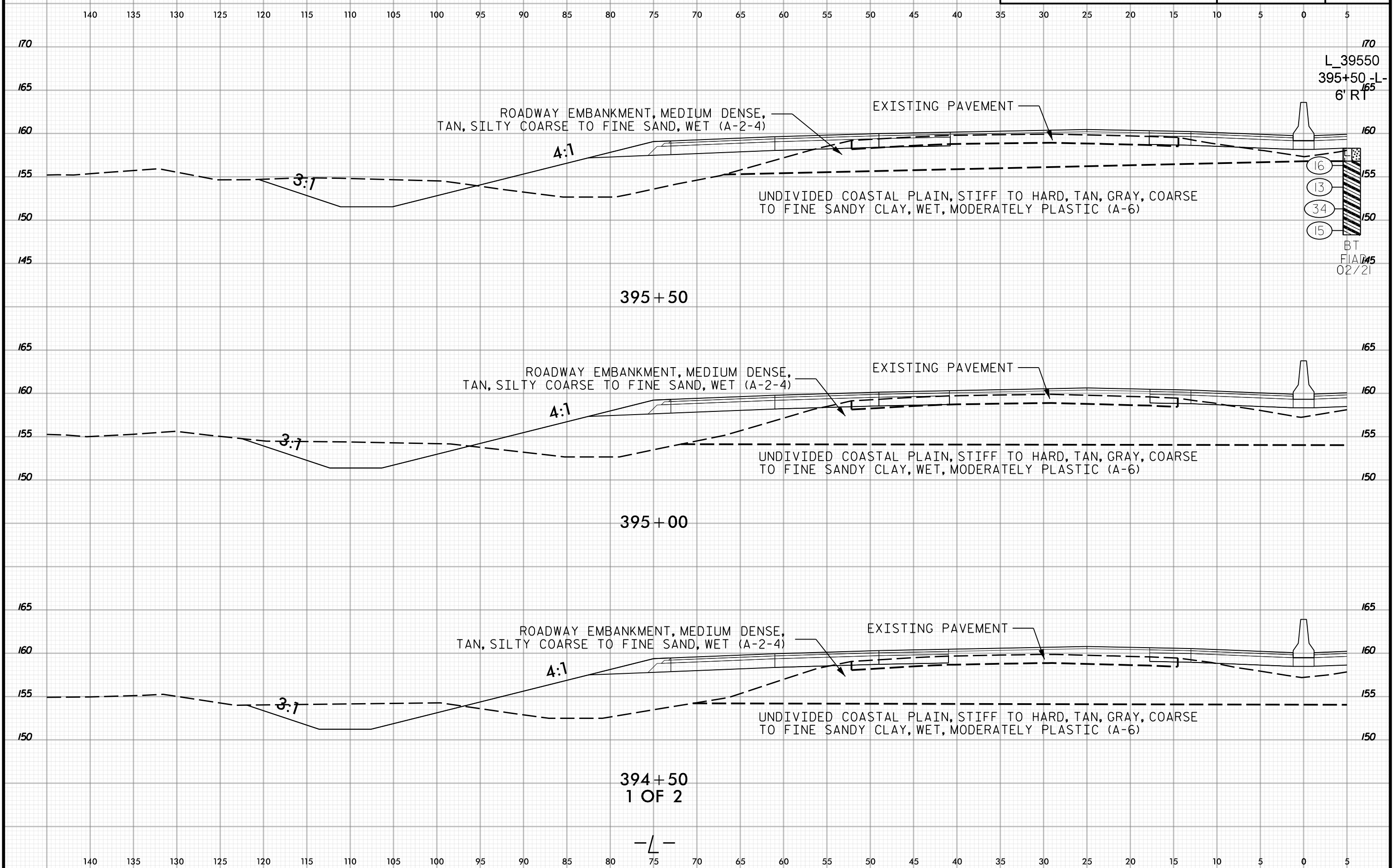

395 + 50

395 + 00

394 + 50  
1 OF 2

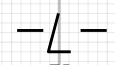

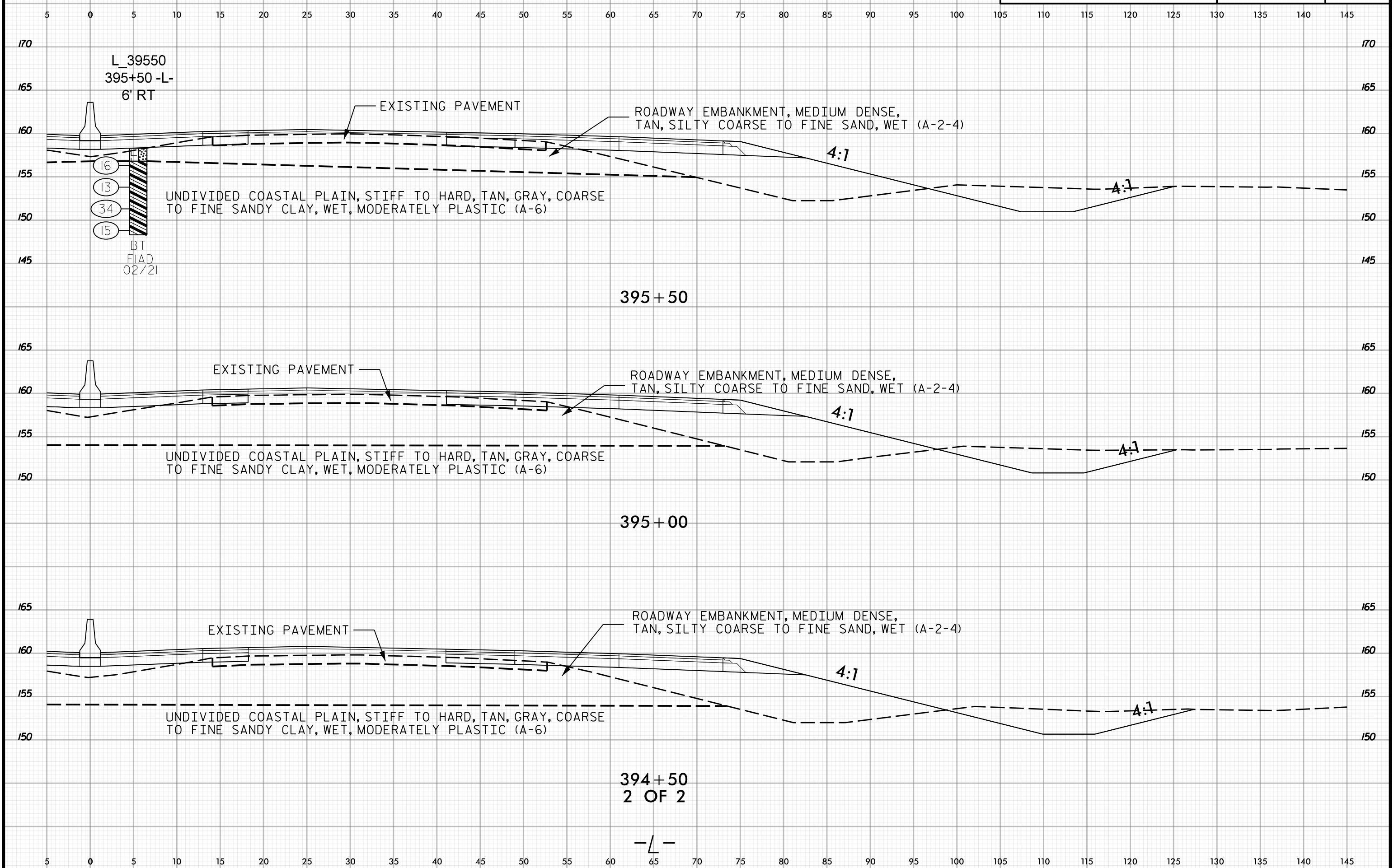
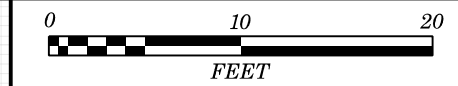





140 135 130 125 120 115 110 105 100 95 90 85 80 75 70 65 60 55 50 45 40 35 30 25 20 15 10 5 0 5

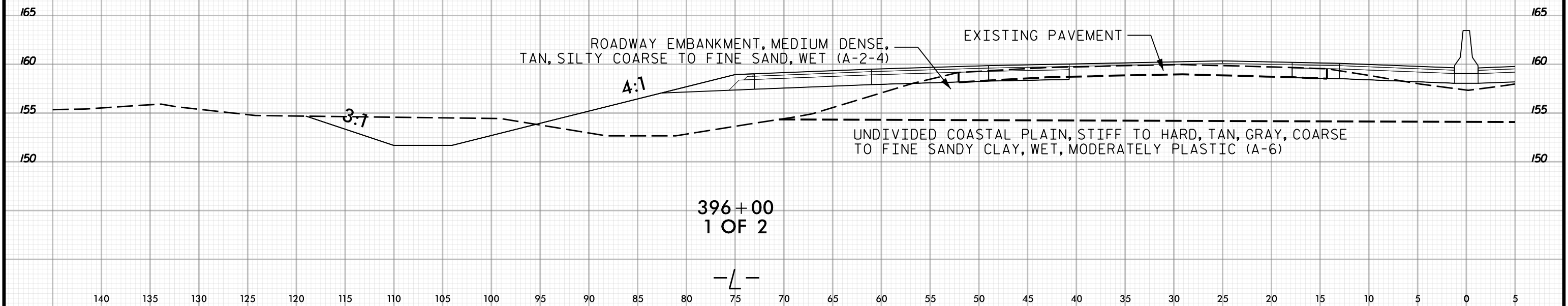
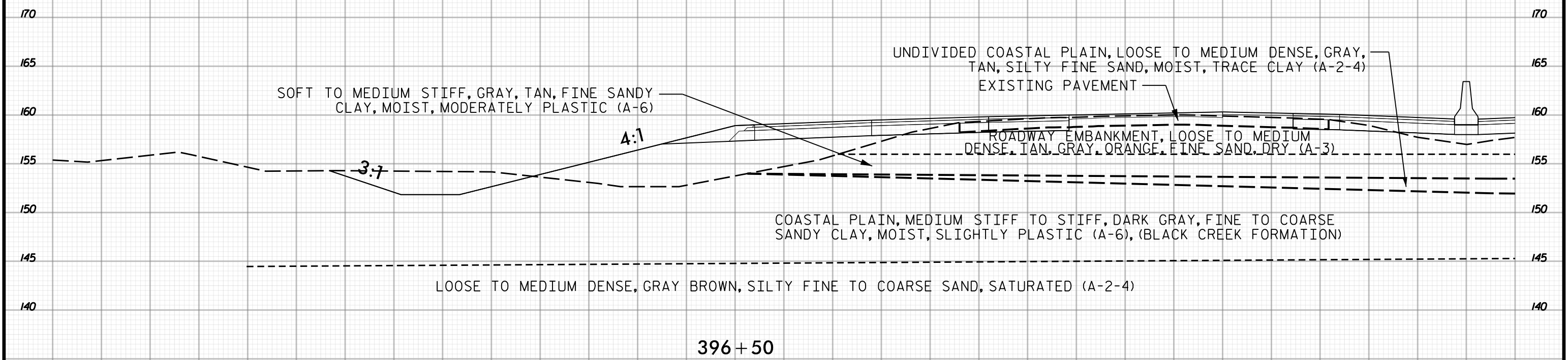

140 135 130 125 120 115 110 105 100 95 90 85 80 75 70 65 60 55 50 45 40 35 30 25 20 15 10 5 0 5

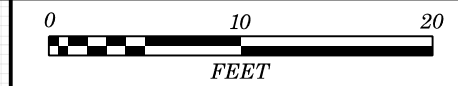

5 0 5 10 15 20 25 30 35 40 45 50 55 60 65 70 75 80 85 90 95 100 105 110 115 120 125 130 135 140 145

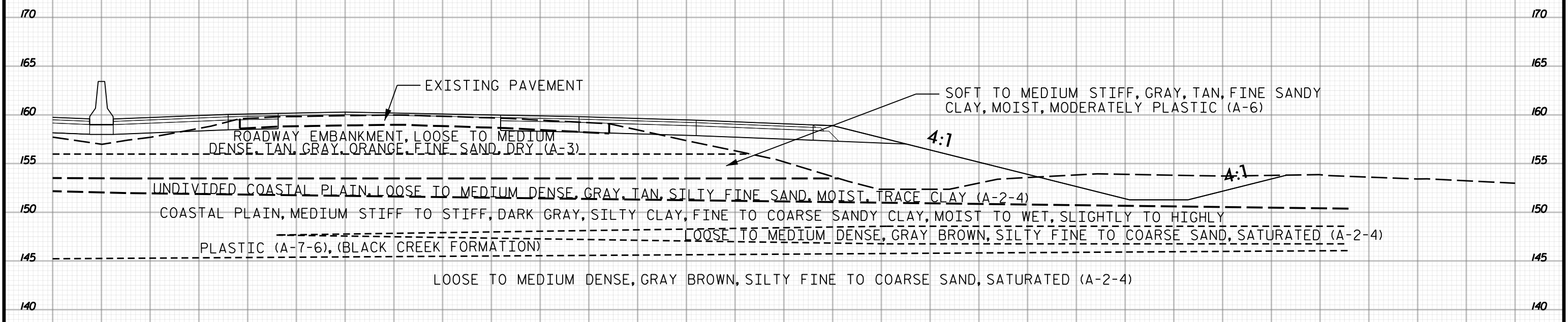

396+50

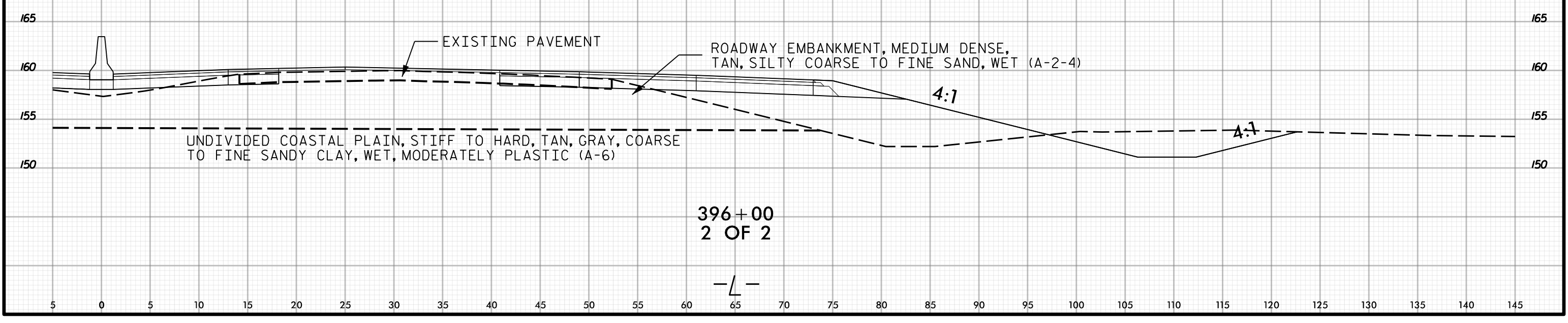

396+00  
2 OF 2

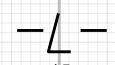

5 0 5 10 15 20 25 30 35 40 45 50 55 60 65 70 75 80 85 90 95 100 105 110 115 120 125 130 135 140 145



140 135 130 125 120 115 110 105 100 95 90 85 80 75 70 65 60 55 50 45 40 35 30 25 20 15 10 5 0 5

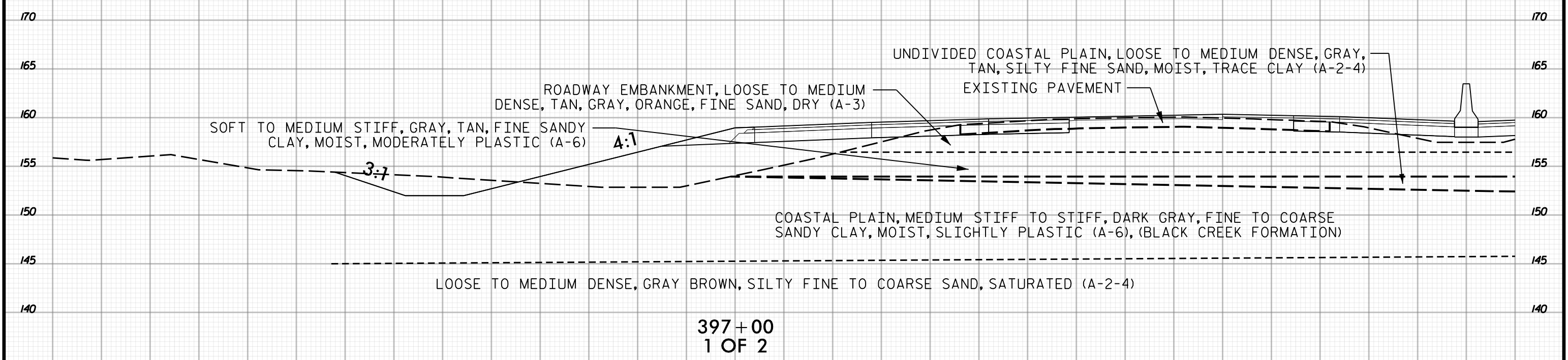
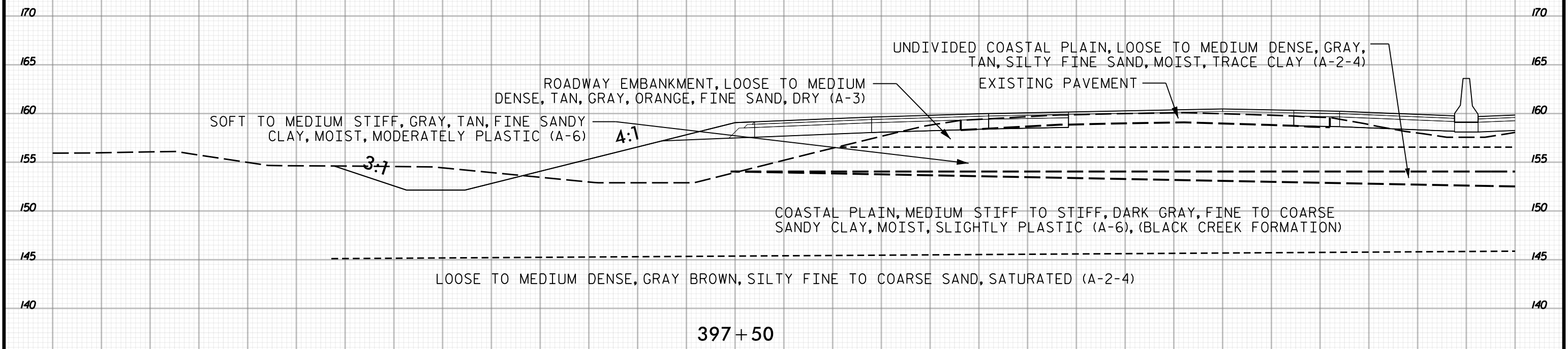

140 135 130 125 120 115 110 105 100 95 90 85 80 75 70 65 60 55 50 45 40 35 30 25 20 15 10 5 0 5



5 0 5 10 15 20 25 30 35 40 45 50 55 60 65 70 75 80 85 90 95 100 105 110 115 120 125 130 135 140 145

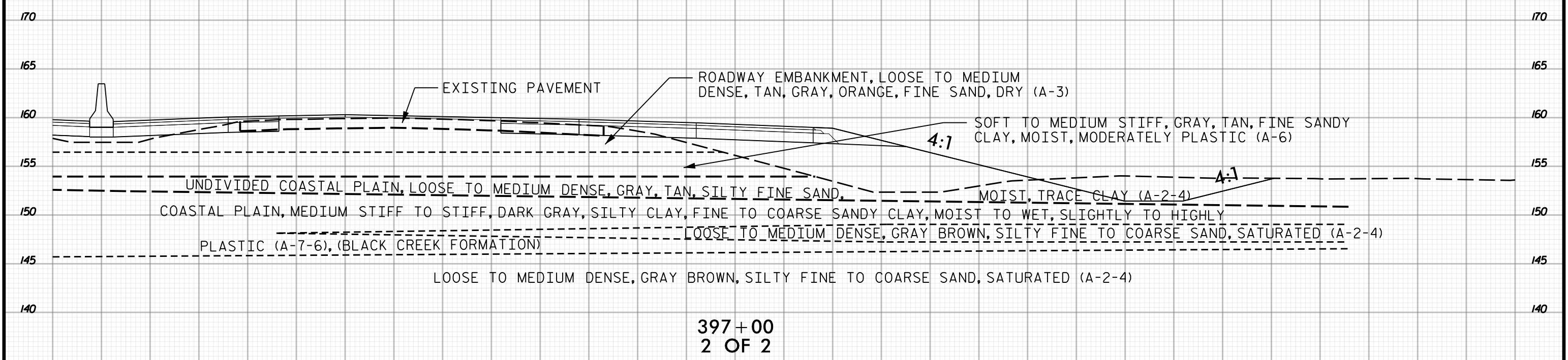
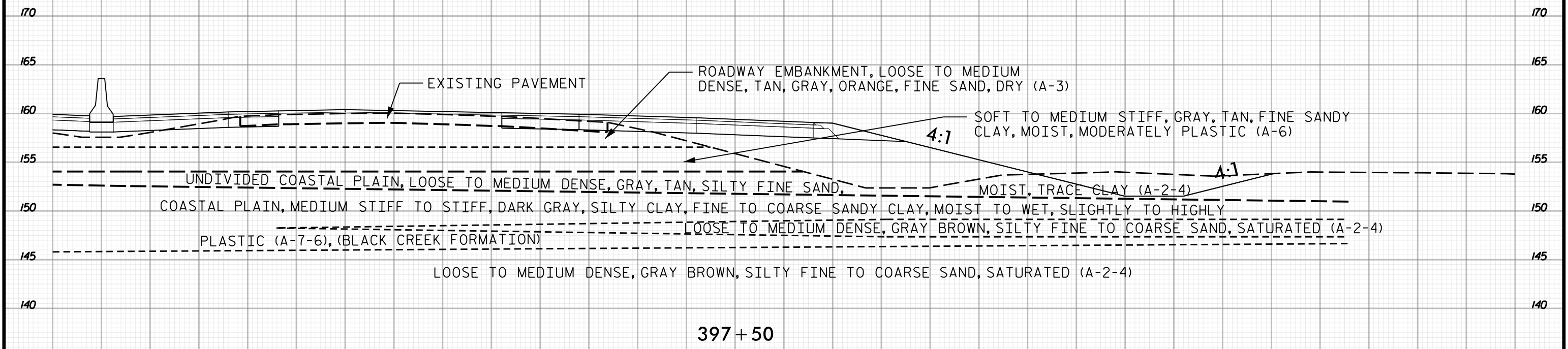

5 0 5 10 15 20 25 30 35 40 45 50 55 60 65 70 75 80 85 90 95 100 105 110 115 120 125 130 135 140 145



140 135 130 125 120 115 110 105 100 95 90 85 80 75 70 65 60 55 50 45 40 35 30 25 20 15 10 5 0 5

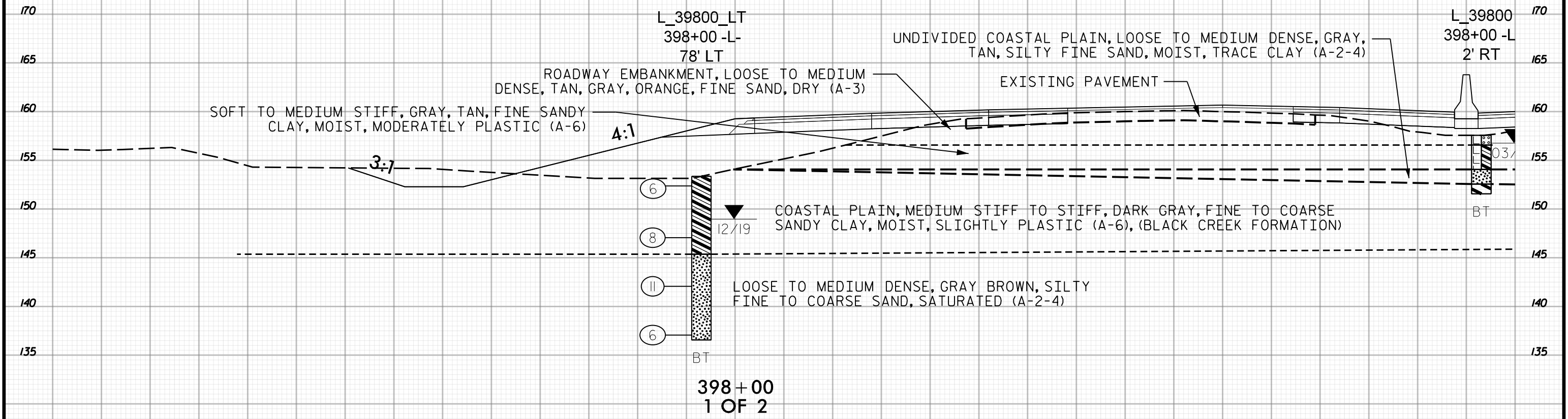
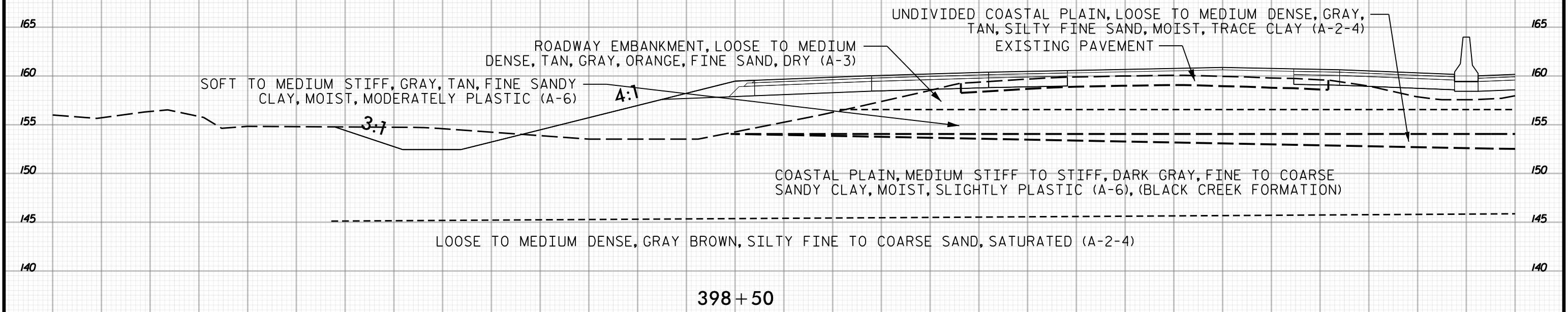

140 135 130 125 120 115 110 105 100 95 90 85 80 75 70 65 60 55 50 45 40 35 30 25 20 15 10 5 0 5

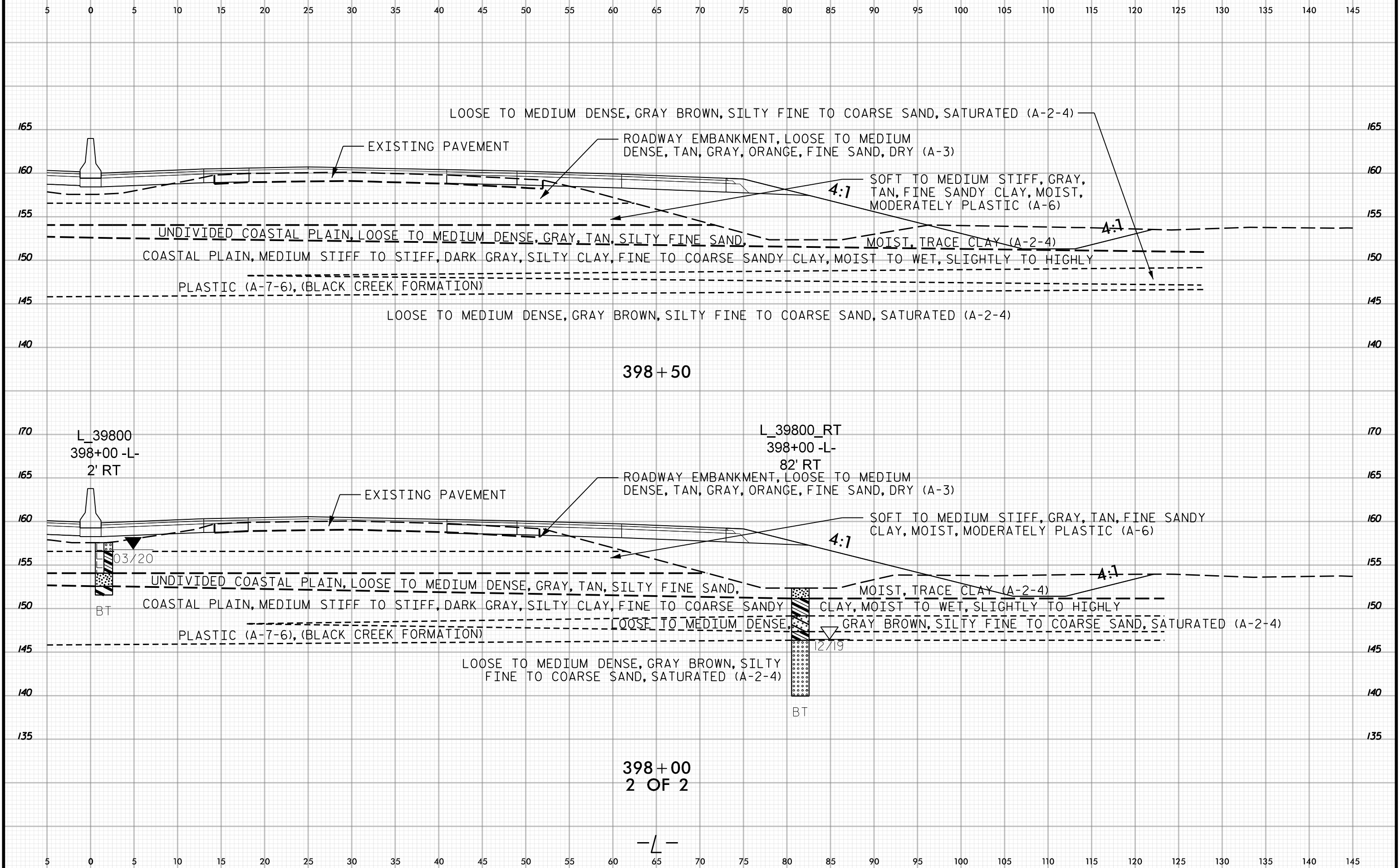

398+00  
2 OF 2

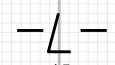

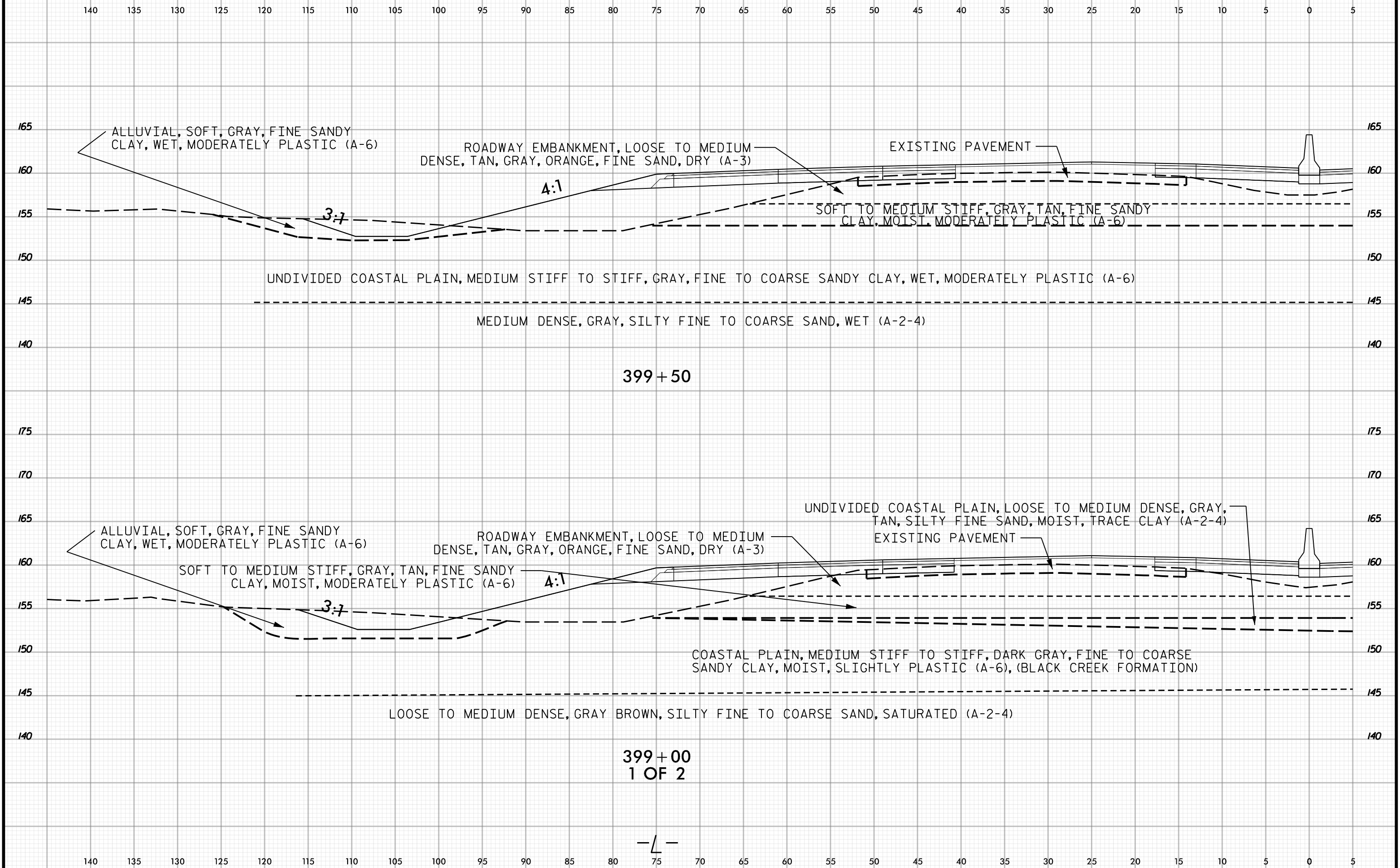
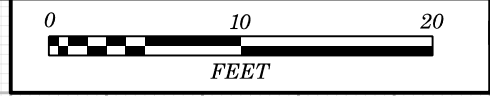

399+00  
1 OF 2

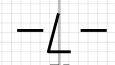

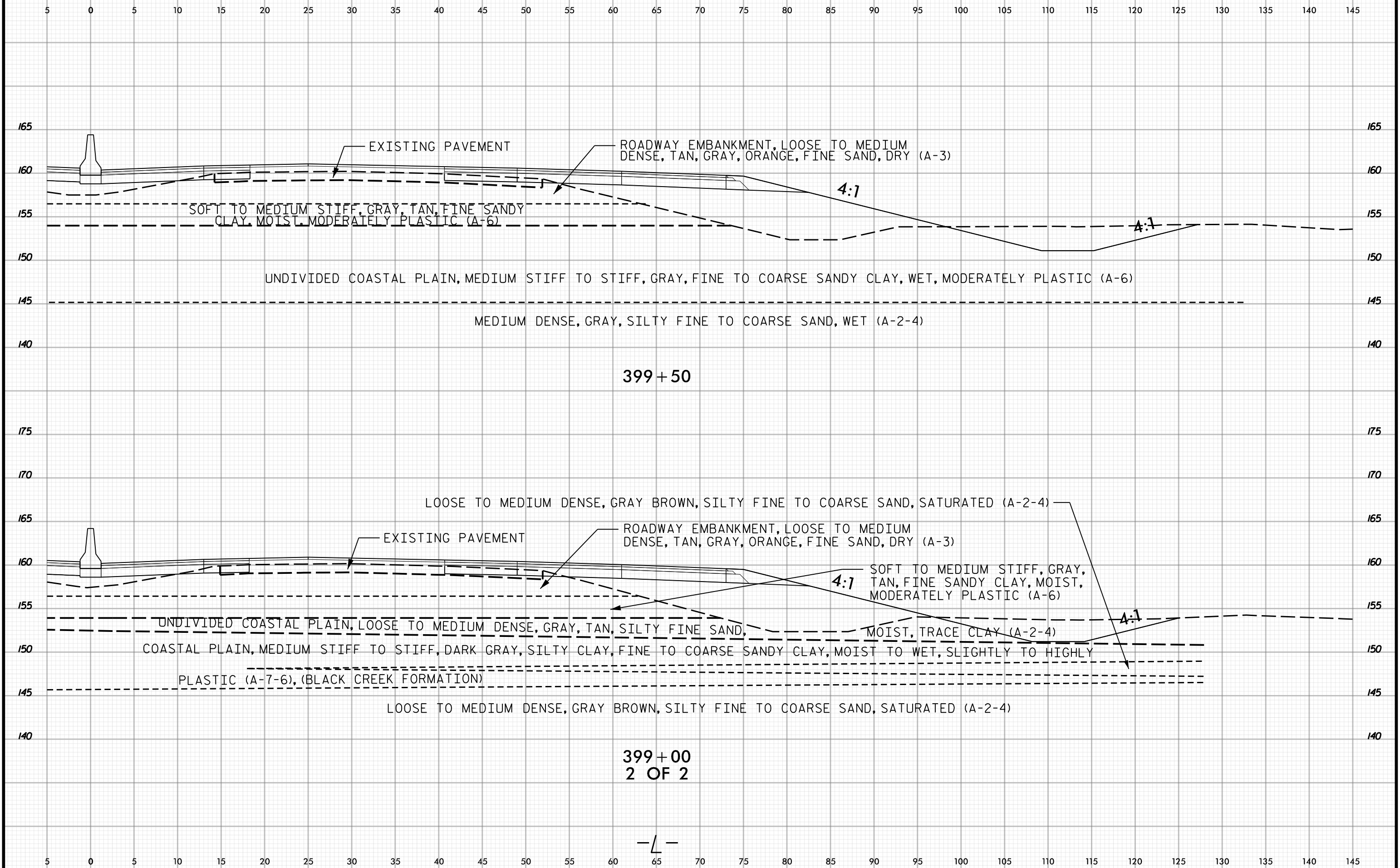
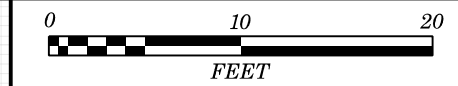

399+00  
2 OF 2

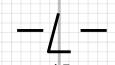





140 135 130 125 120 115 110 105 100 95 90 85 80 75 70 65 60 55 50 45 40 35 30 25 20 15 10 5 0 5

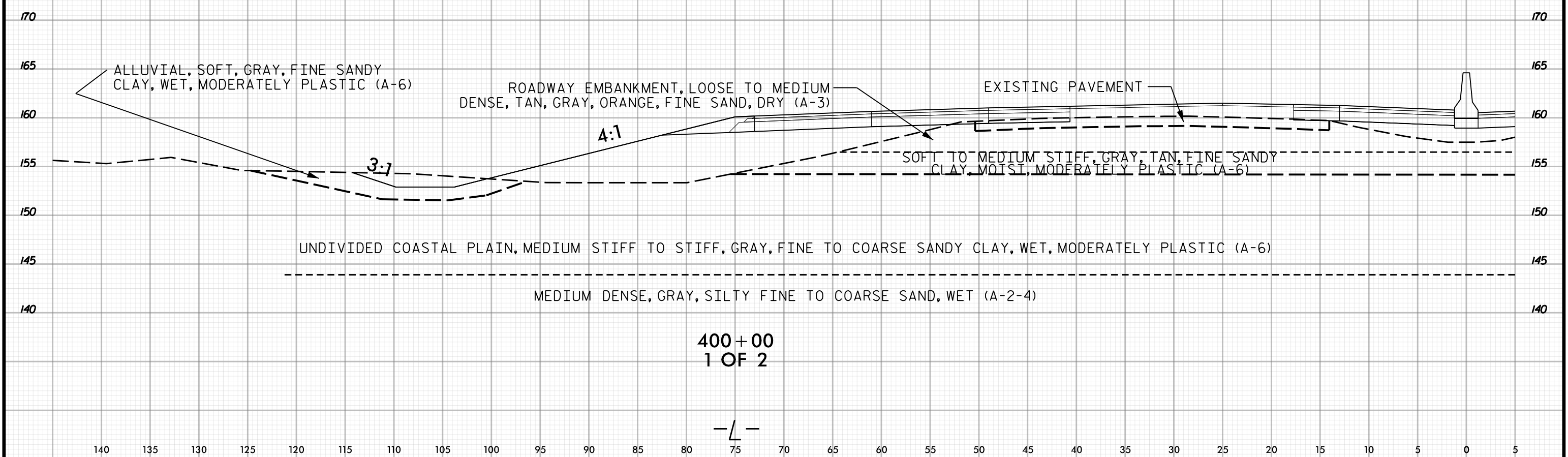
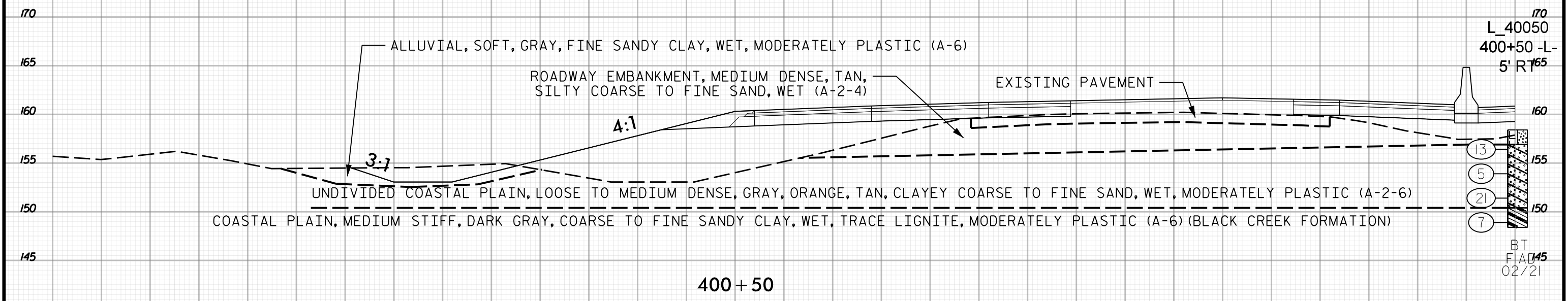

140 135 130 125 120 115 110 105 100 95 90 85 80 75 70 65 60 55 50 45 40 35 30 25 20 15 10 5 0 5



5 0 5 10 15 20 25 30 35 40 45 50 55 60 65 70 75 80 85 90 95 100 105 110 115 120 125 130 135 140 145

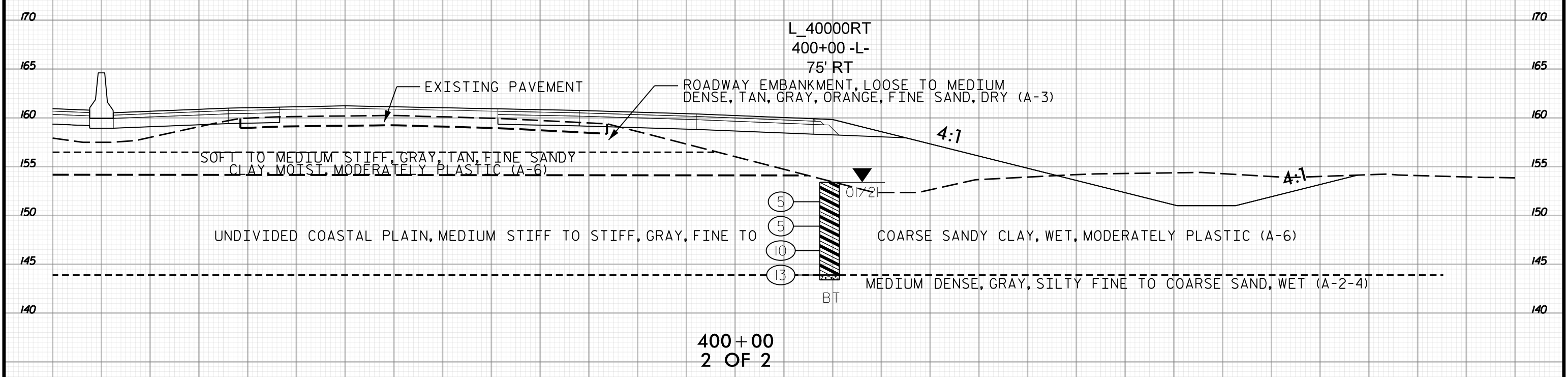
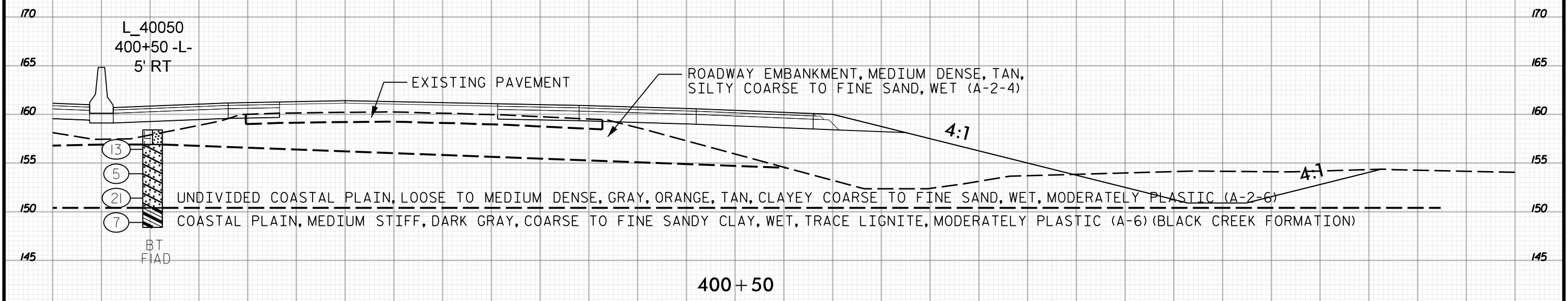

5 0 5 10 15 20 25 30 35 40 45 50 55 60 65 70 75 80 85 90 95 100 105 110 115 120 125 130 135 140 145



140 135 130 125 120 115 110 105 100 95 90 85 80 75 70 65 60 55 50 45 40 35 30 25 20 15 10 5 0 5

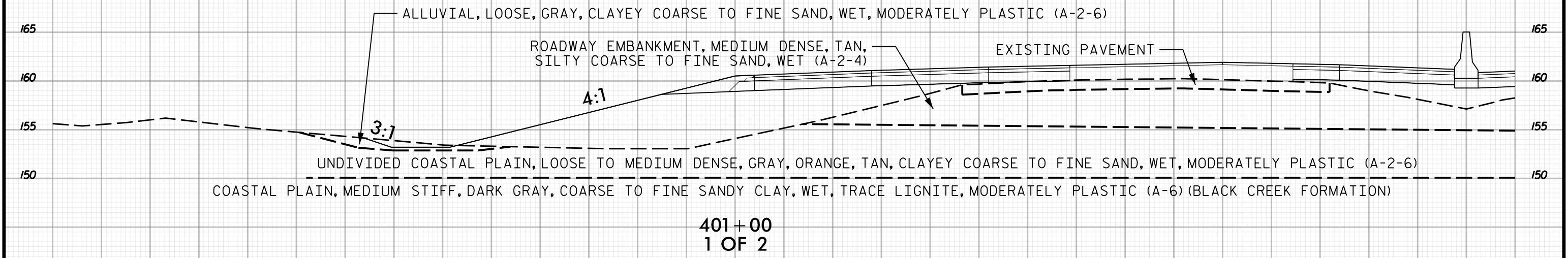
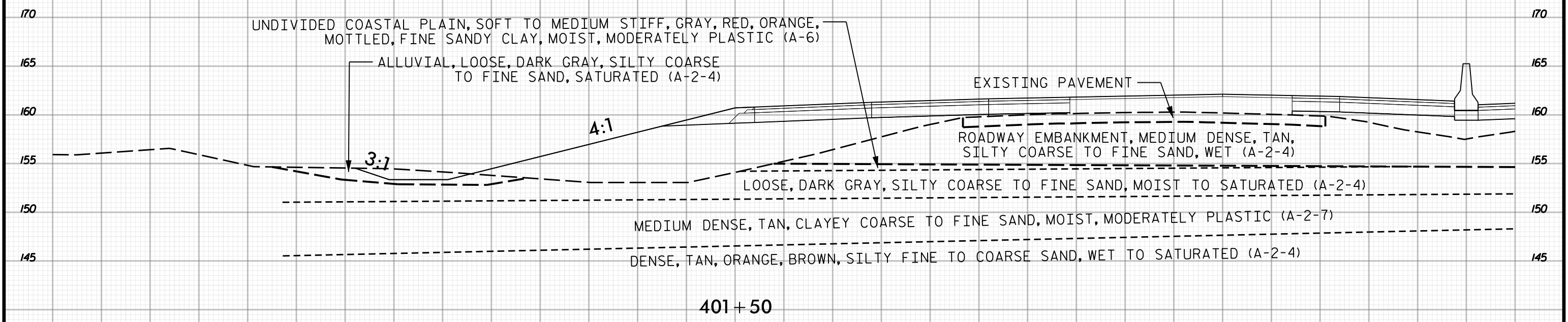

140 135 130 125 120 115 110 105 100 95 90 85 80 75 70 65 60 55 50 45 40 35 30 25 20 15 10 5 0 5

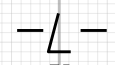



5 0 5 10 15 20 25 30 35 40 45 50 55 60 65 70 75 80 85 90 95 100 105 110 115 120 125 130 135 140 145

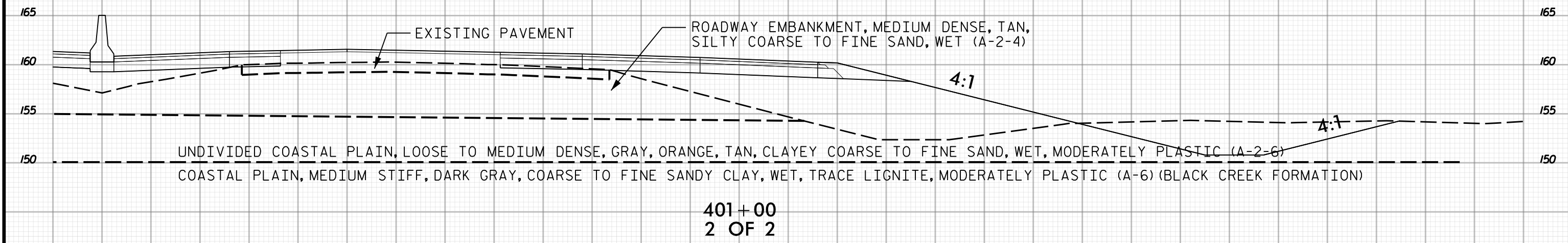
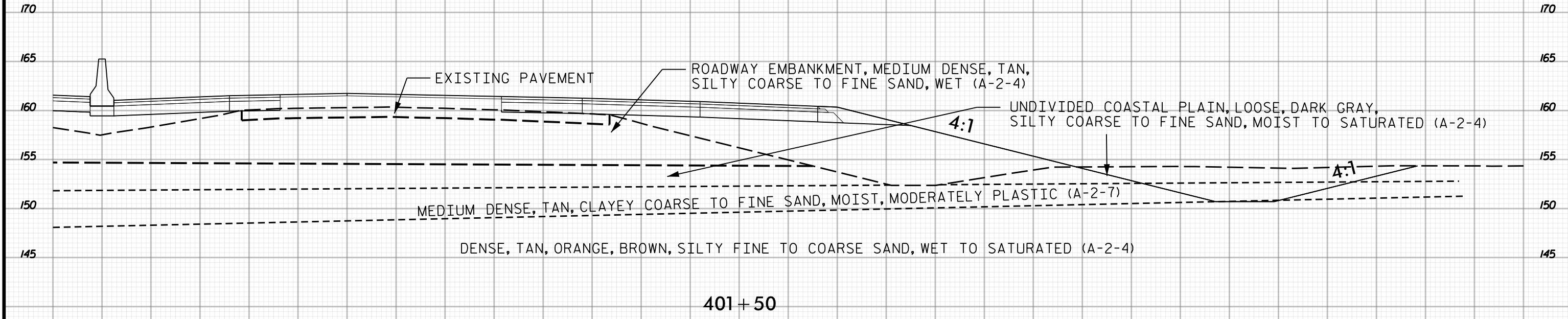

5 0 5 10 15 20 25 30 35 40 45 50 55 60 65 70 75 80 85 90 95 100 105 110 115 120 125 130 135 140 145

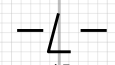

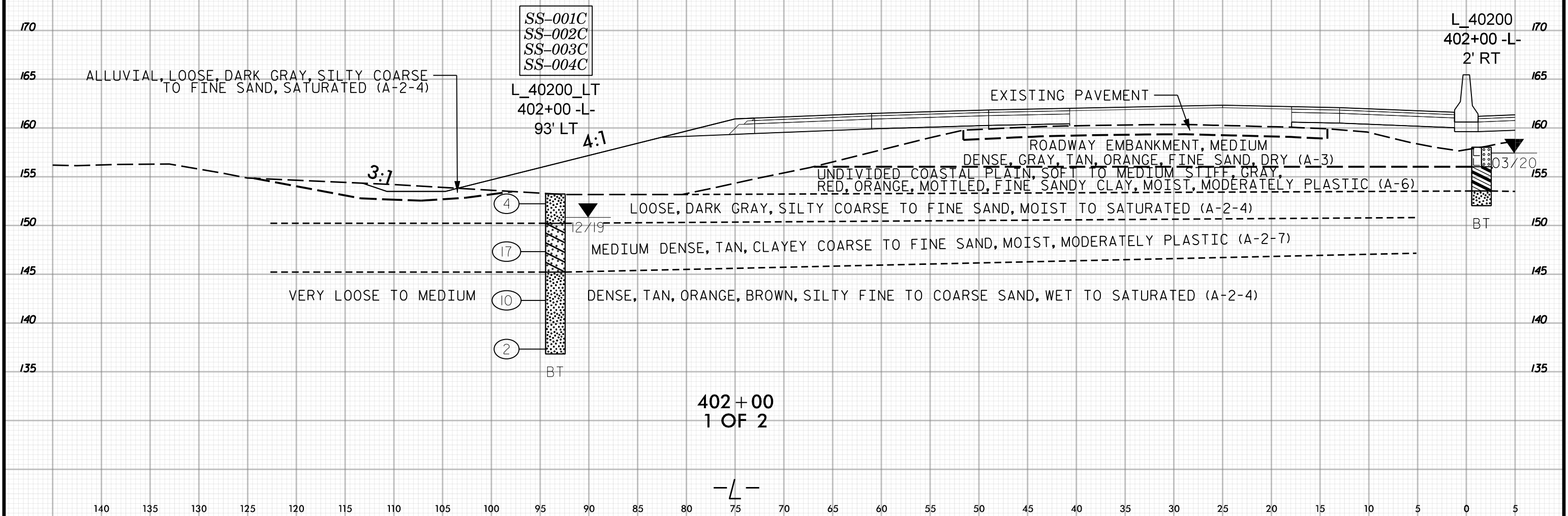
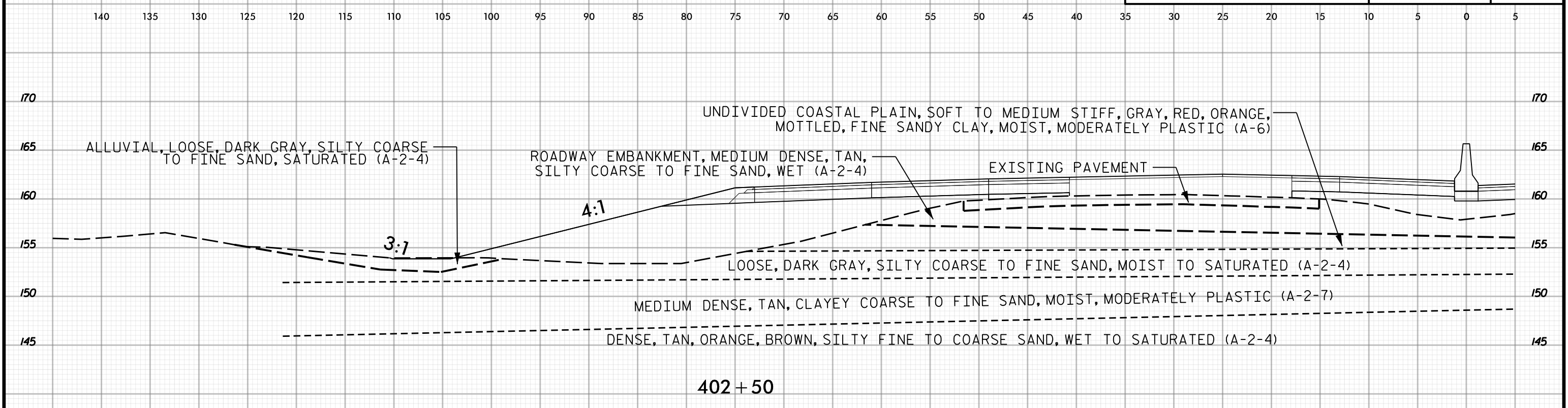

402 + 00  
1 OF 2

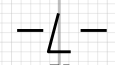

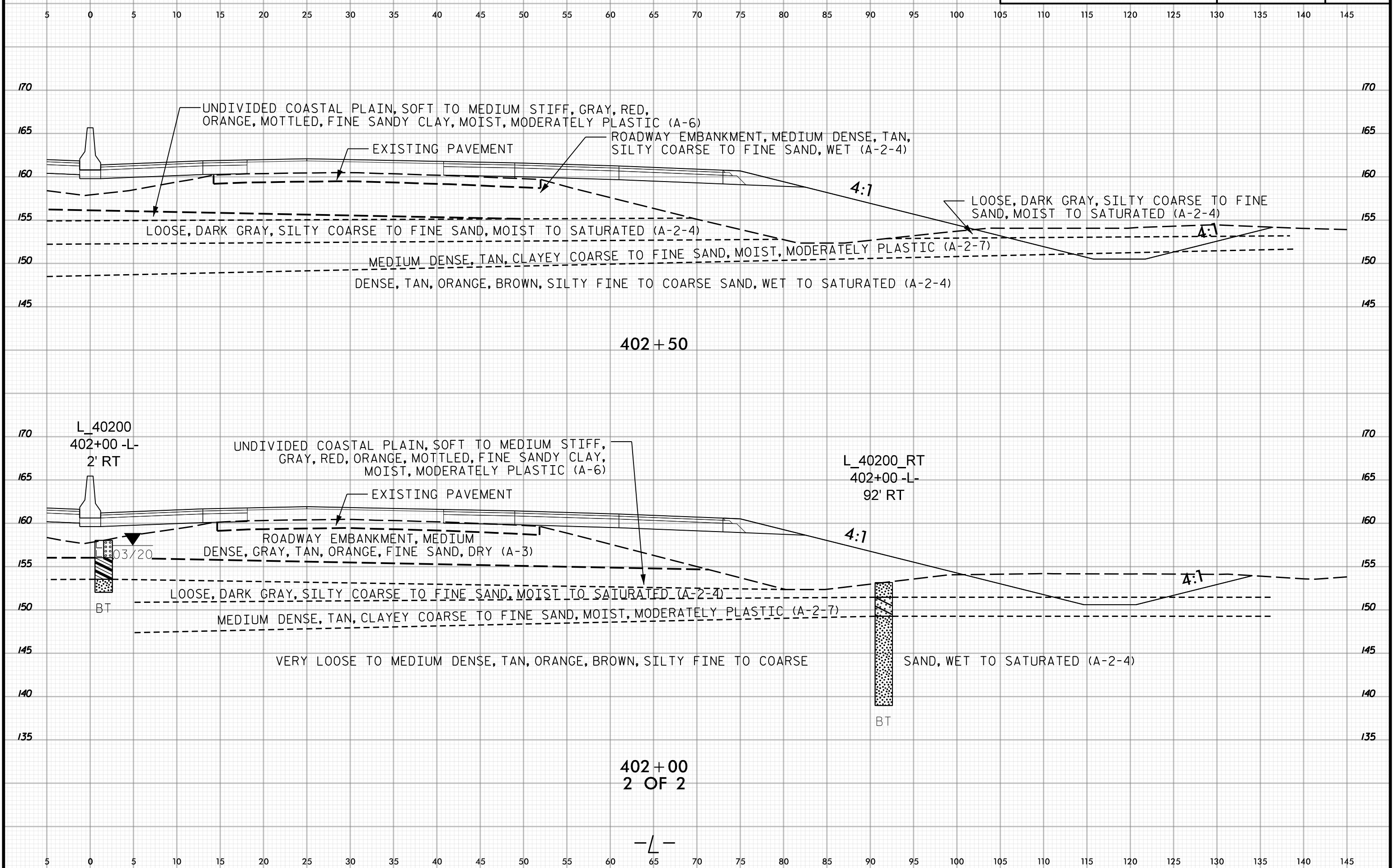

402 + 50

402 + 00  
2 OF 2

-L-



140 135 130 125 120 115 110 105 100 95 90 85 80 75 70 65 60 55 50 45 40 35 30 25 20 15 10 5 0 5

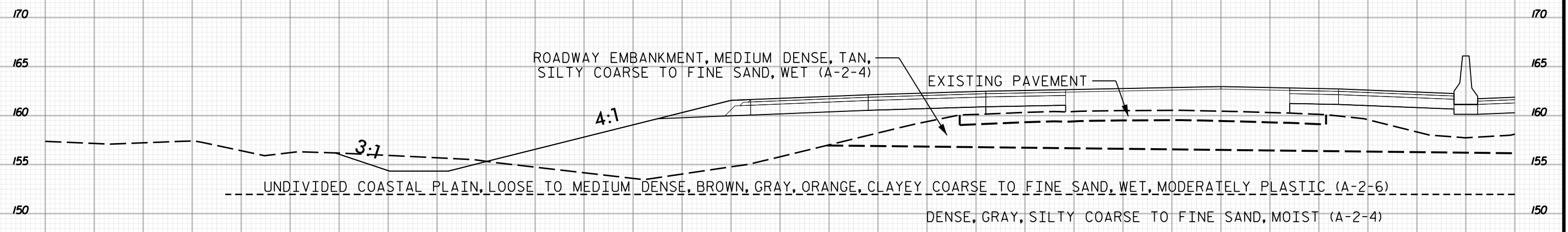

403 + 50

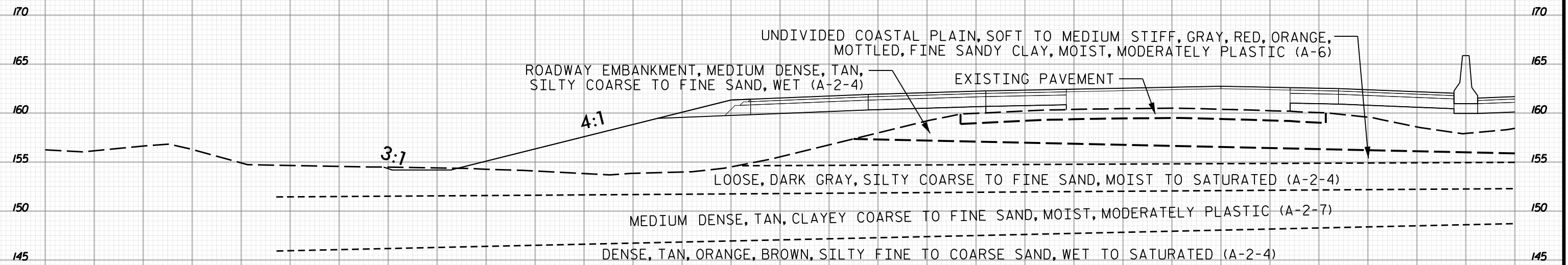

403 + 00  
1 OF 2

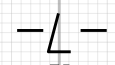

140 135 130 125 120 115 110 105 100 95 90 85 80 75 70 65 60 55 50 45 40 35 30 25 20 15 10 5 0 5



5 0 5 10 15 20 25 30 35 40 45 50 55 60 65 70 75 80 85 90 95 100 105 110 115 120 125 130 135 140 145

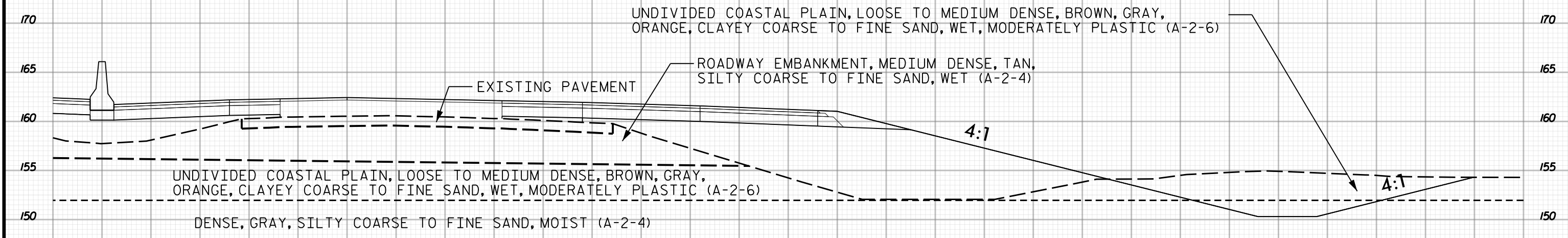

403+50

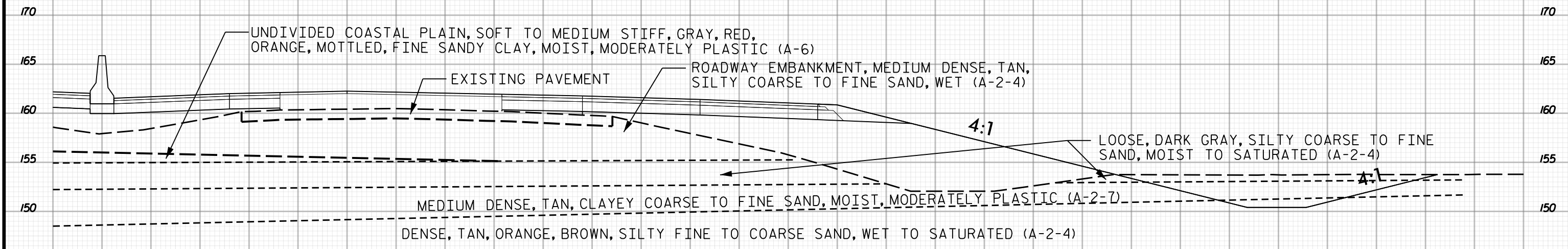

403+00  
2 OF 2

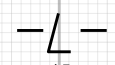

5 0 5 10 15 20 25 30 35 40 45 50 55 60 65 70 75 80 85 90 95 100 105 110 115 120 125 130 135 140 145





140 135 130 125 120 115 110 105 100 95 90 85 80 75 70 65 60 55 50 45 40 35 30 25 20 15 10 5 0 5

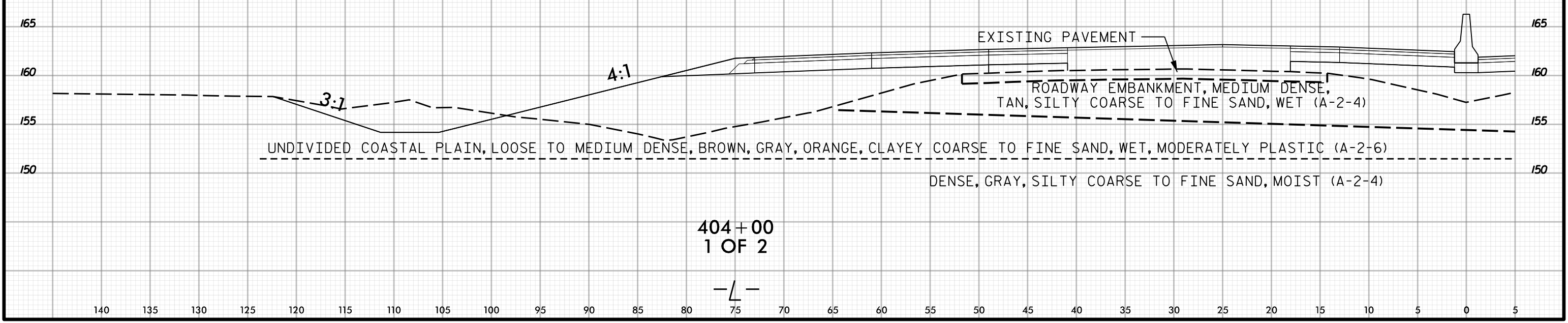
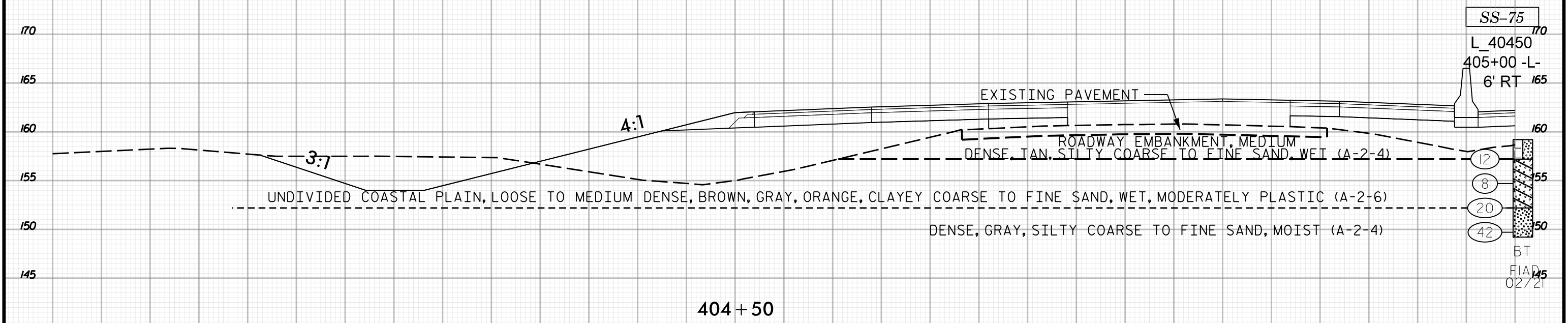

140 135 130 125 120 115 110 105 100 95 90 85 80 75 70 65 60 55 50 45 40 35 30 25 20 15 10 5 0 5

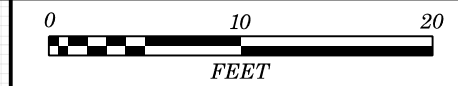

5 0 5 10 15 20 25 30 35 40 45 50 55 60 65 70 75 80 85 90 95 100 105 110 115 120 125 130 135 140 145

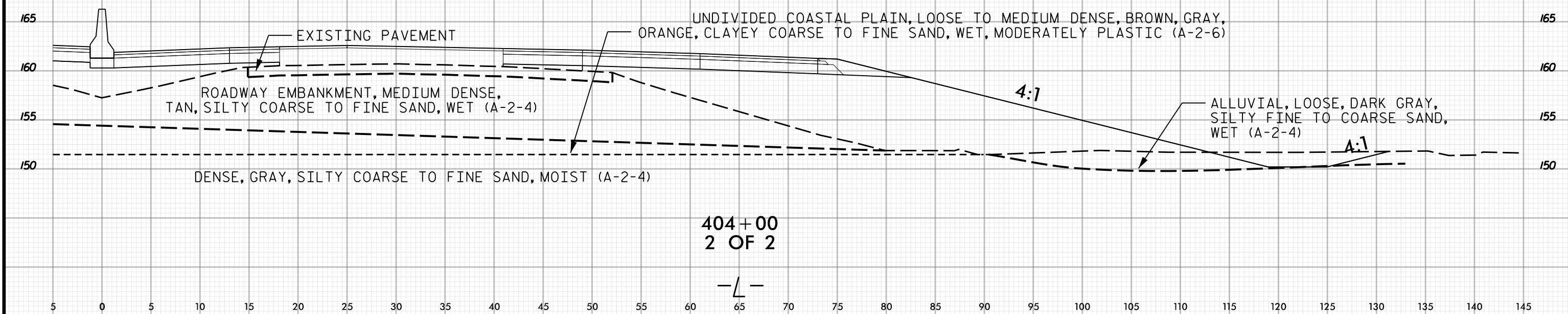
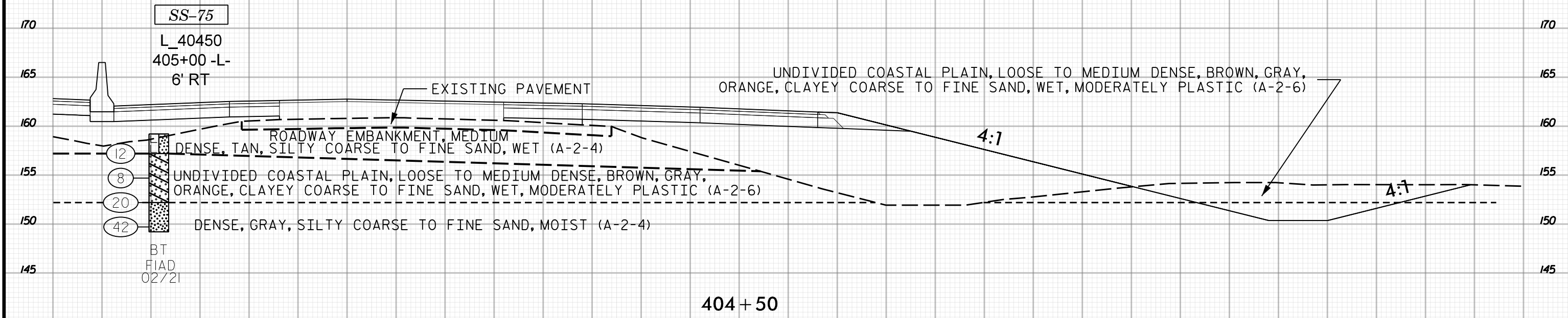

5 0 5 10 15 20 25 30 35 40 45 50 55 60 65 70 75 80 85 90 95 100 105 110 115 120 125 130 135 140 145



140 135 130 125 120 115 110 105 100 95 90 85 80 75 70 65 60 55 50 45 40 35 30 25 20 15 10 5 0 5

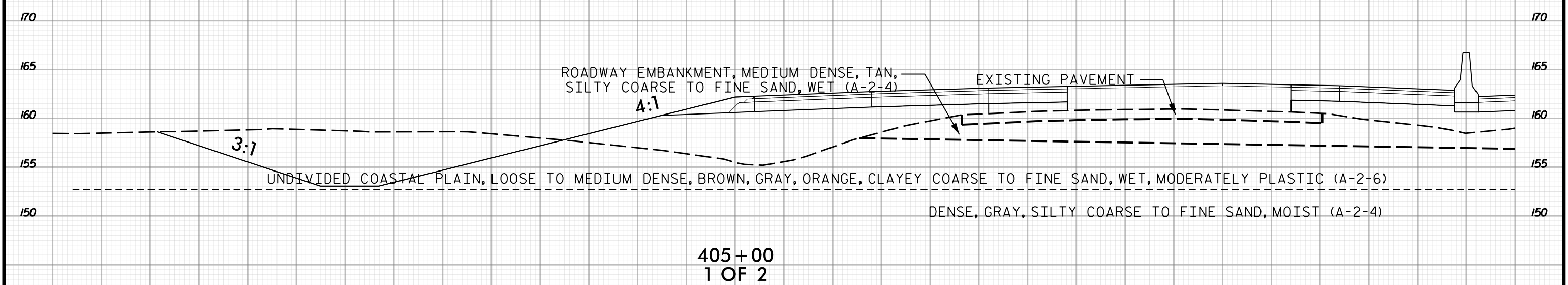
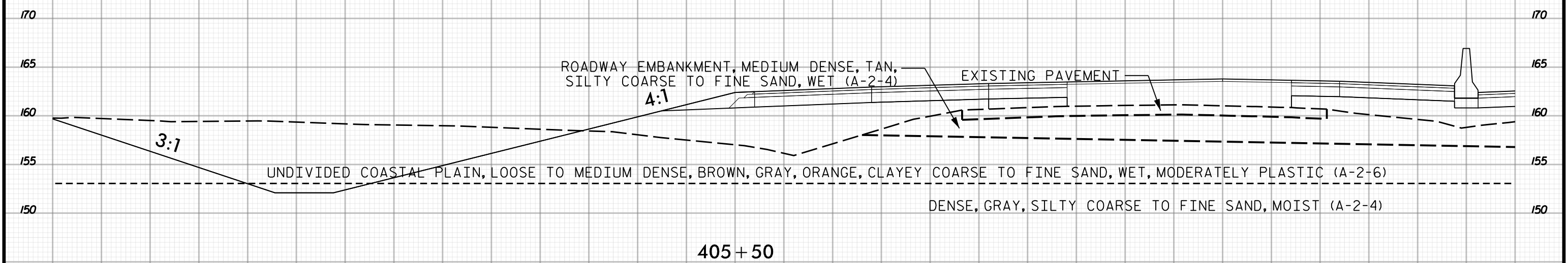

140 135 130 125 120 115 110 105 100 95 90 85 80 75 70 65 60 55 50 45 40 35 30 25 20 15 10 5 0 5



5 0 5 10 15 20 25 30 35 40 45 50 55 60 65 70 75 80 85 90 95 100 105 110 115 120 125 130 135 140 145

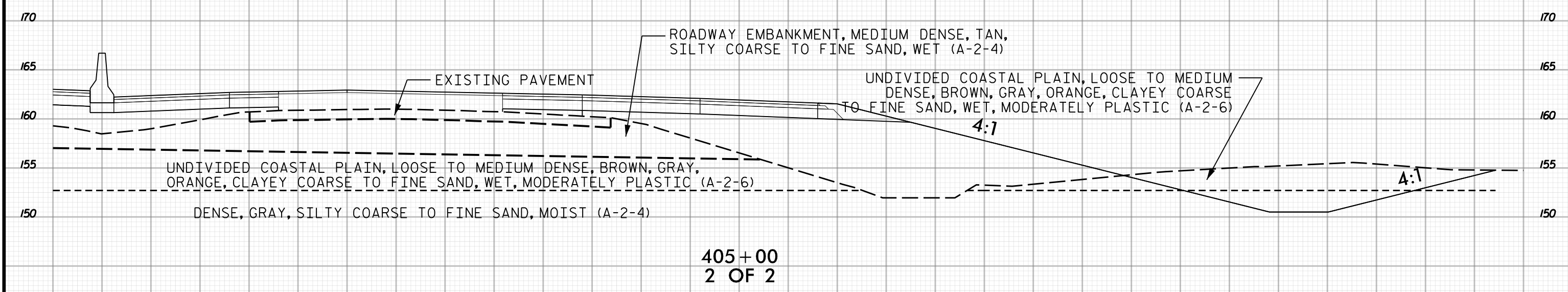
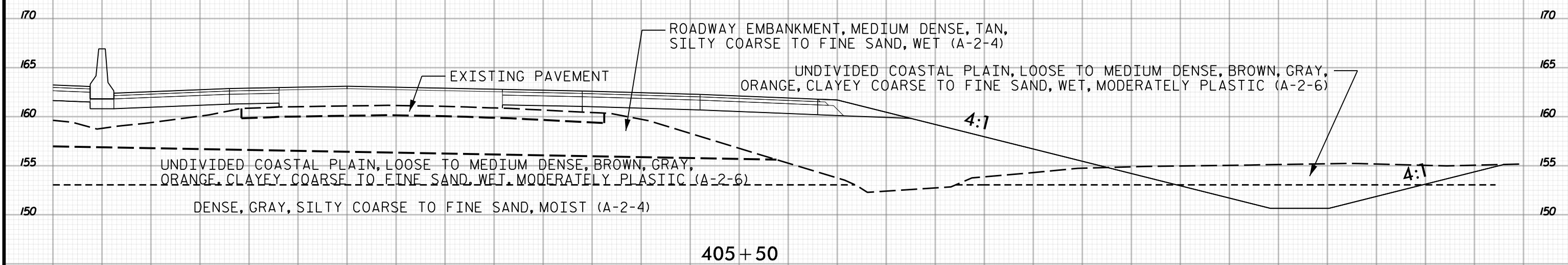

5 0 5 10 15 20 25 30 35 40 45 50 55 60 65 70 75 80 85 90 95 100 105 110 115 120 125 130 135 140 145



140 135 130 125 120 115 110 105 100 95 90 85 80 75 70 65 60 55 50 45 40 35 30 25 20 15 10 5 0 5

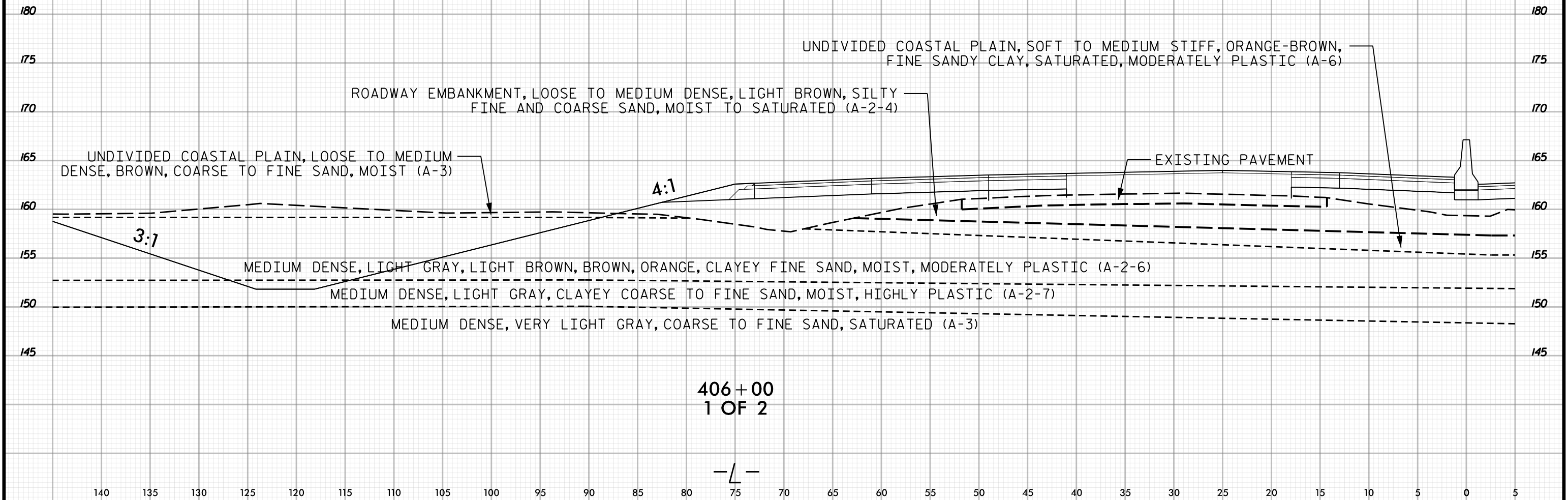
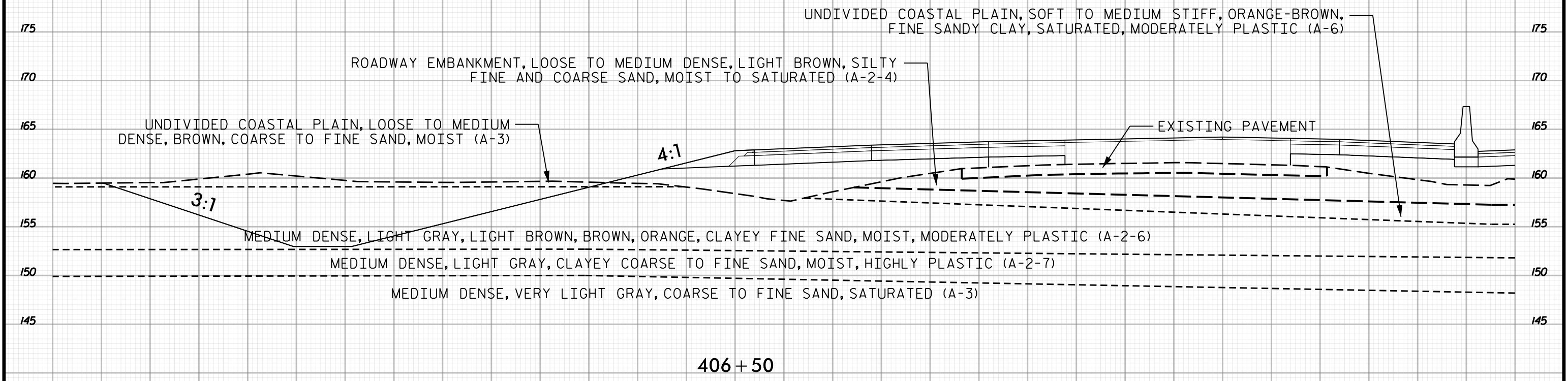

140 135 130 125 120 115 110 105 100 95 90 85 80 75 70 65 60 55 50 45 40 35 30 25 20 15 10 5 0 5

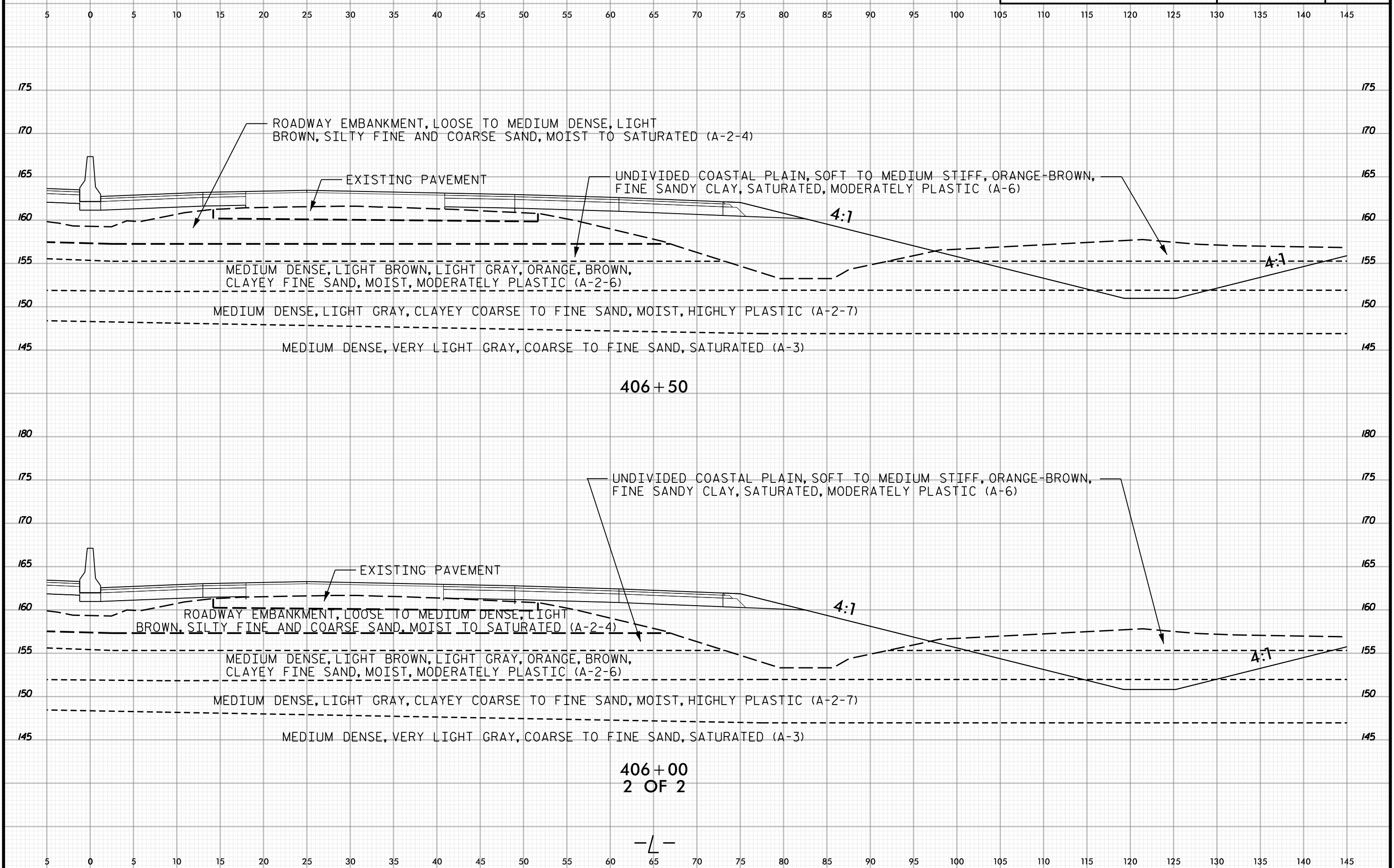

406+50

406+00  
2 OF 2

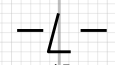

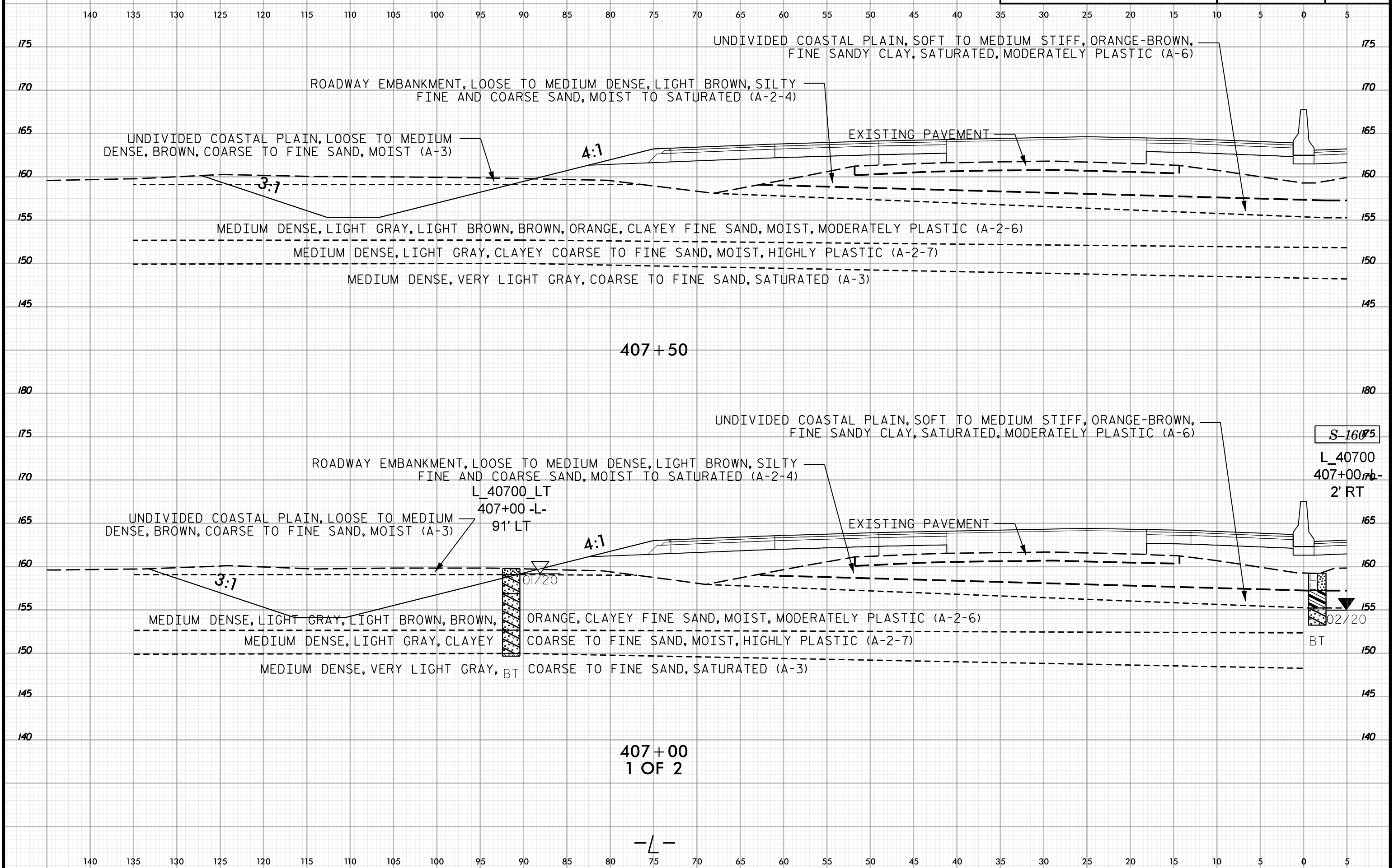

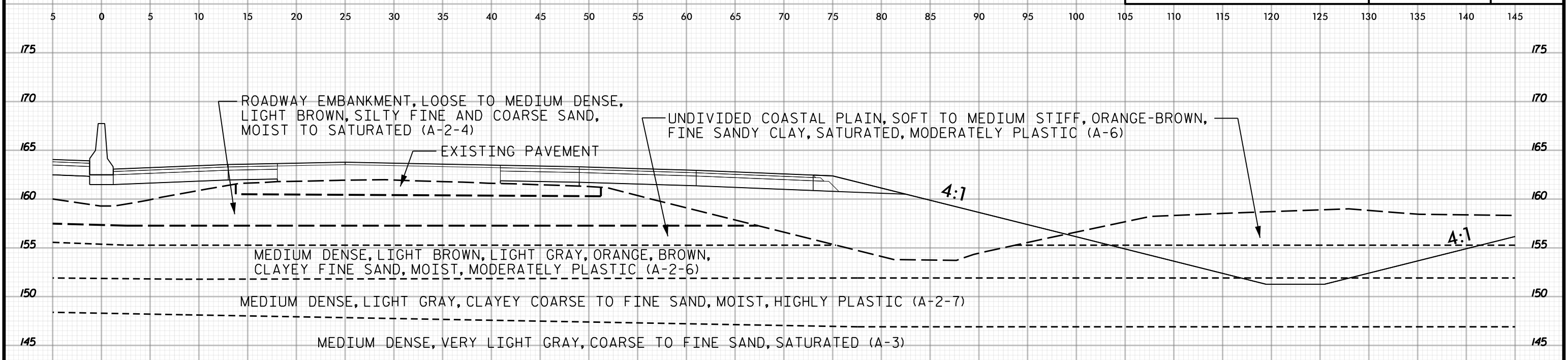
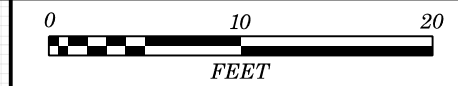

407 + 50

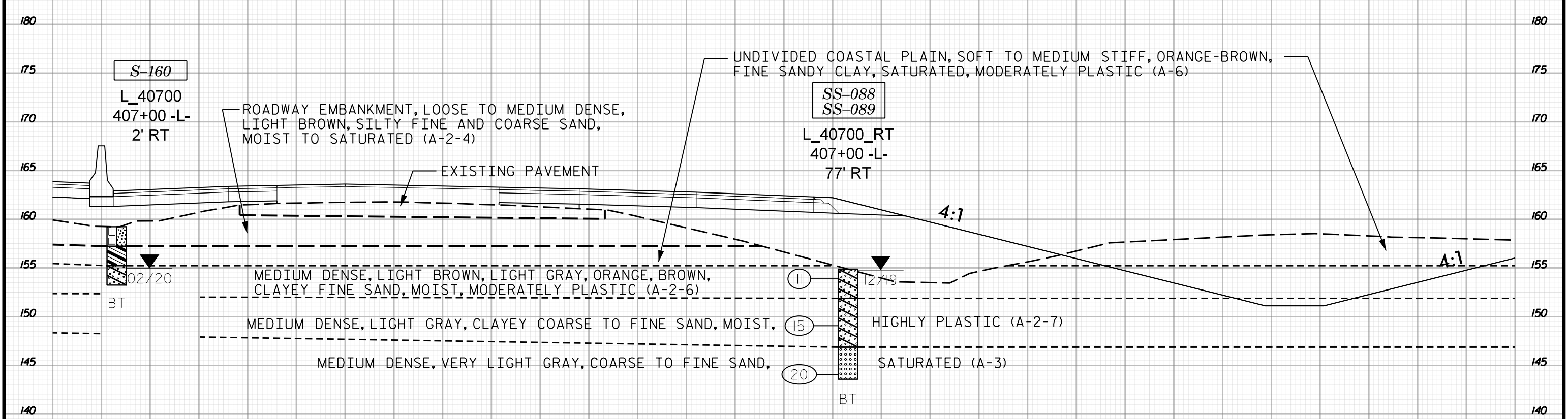

407 + 00  
2 OF 2



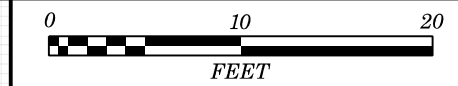

140 135 130 125 120 115 110 105 100 95 90 85 80 75 70 65 60 55 50 45 40 35 30 25 20 15 10 5 0 5

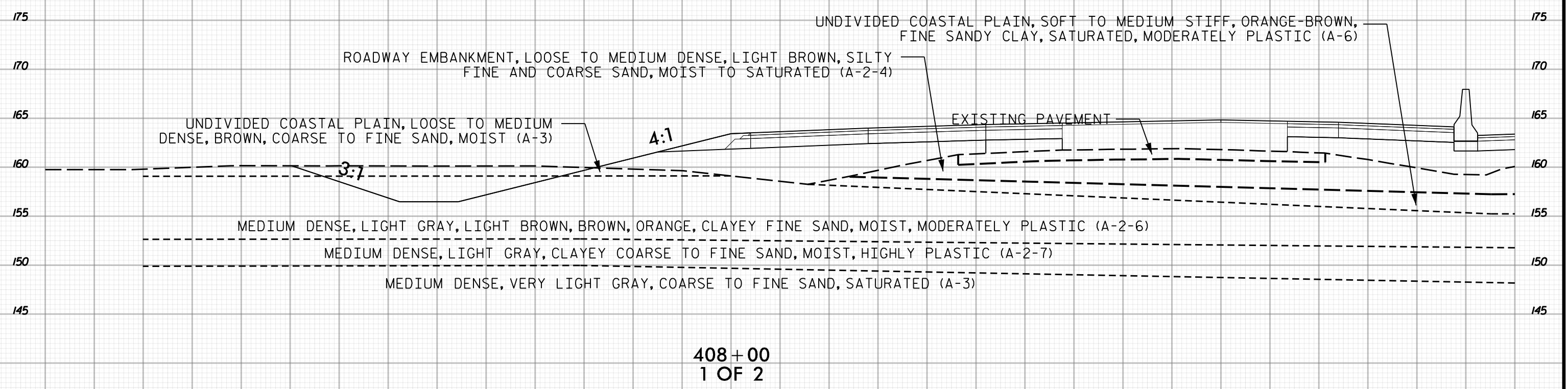
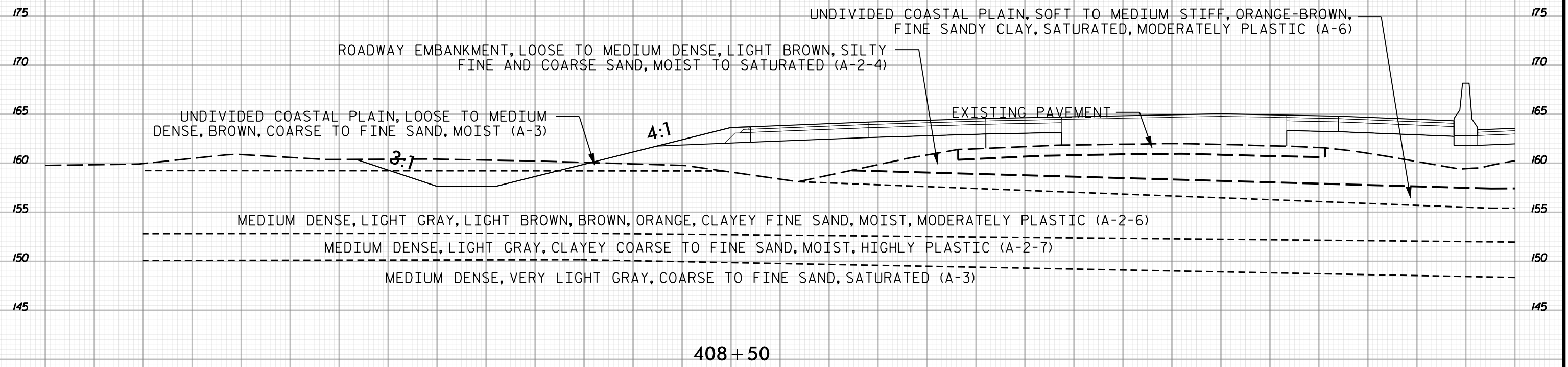

140 135 130 125 120 115 110 105 100 95 90 85 80 75 70 65 60 55 50 45 40 35 30 25 20 15 10 5 0 5

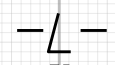



5 0 5 10 15 20 25 30 35 40 45 50 55 60 65 70 75 80 85 90 95 100 105 110 115 120 125 130 135 140 145

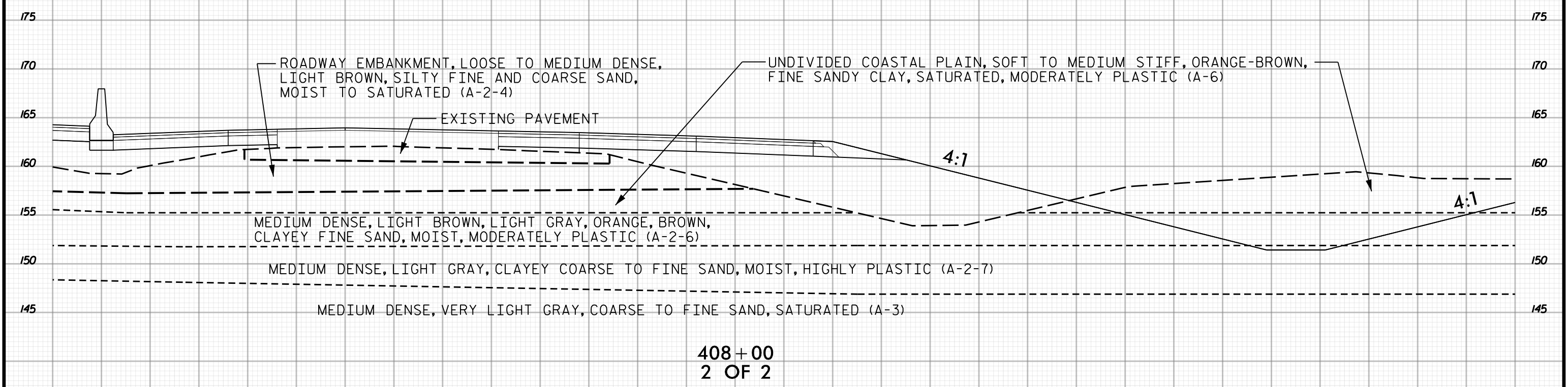
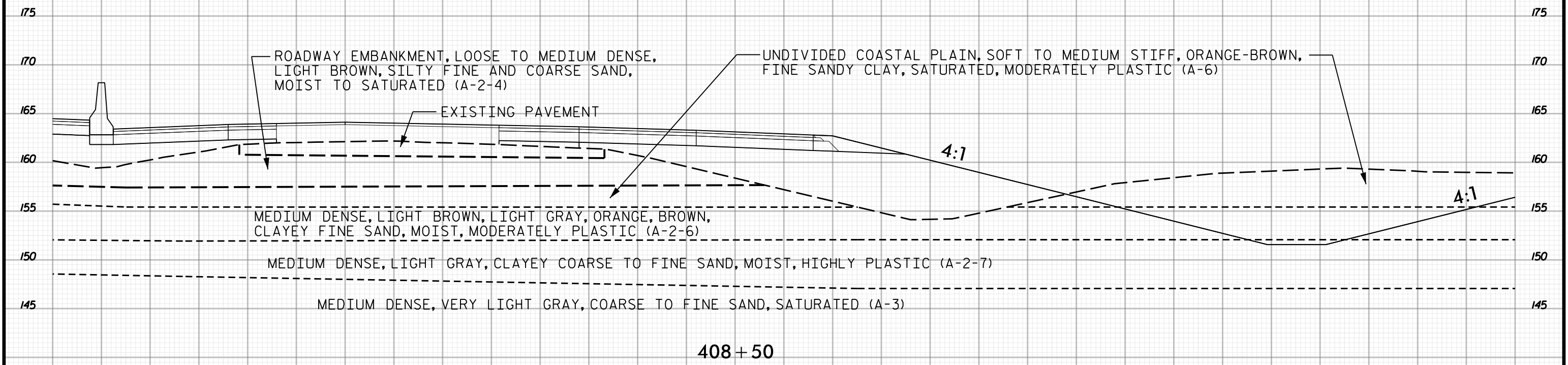

5 0 5 10 15 20 25 30 35 40 45 50 55 60 65 70 75 80 85 90 95 100 105 110 115 120 125 130 135 140 145

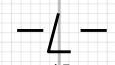

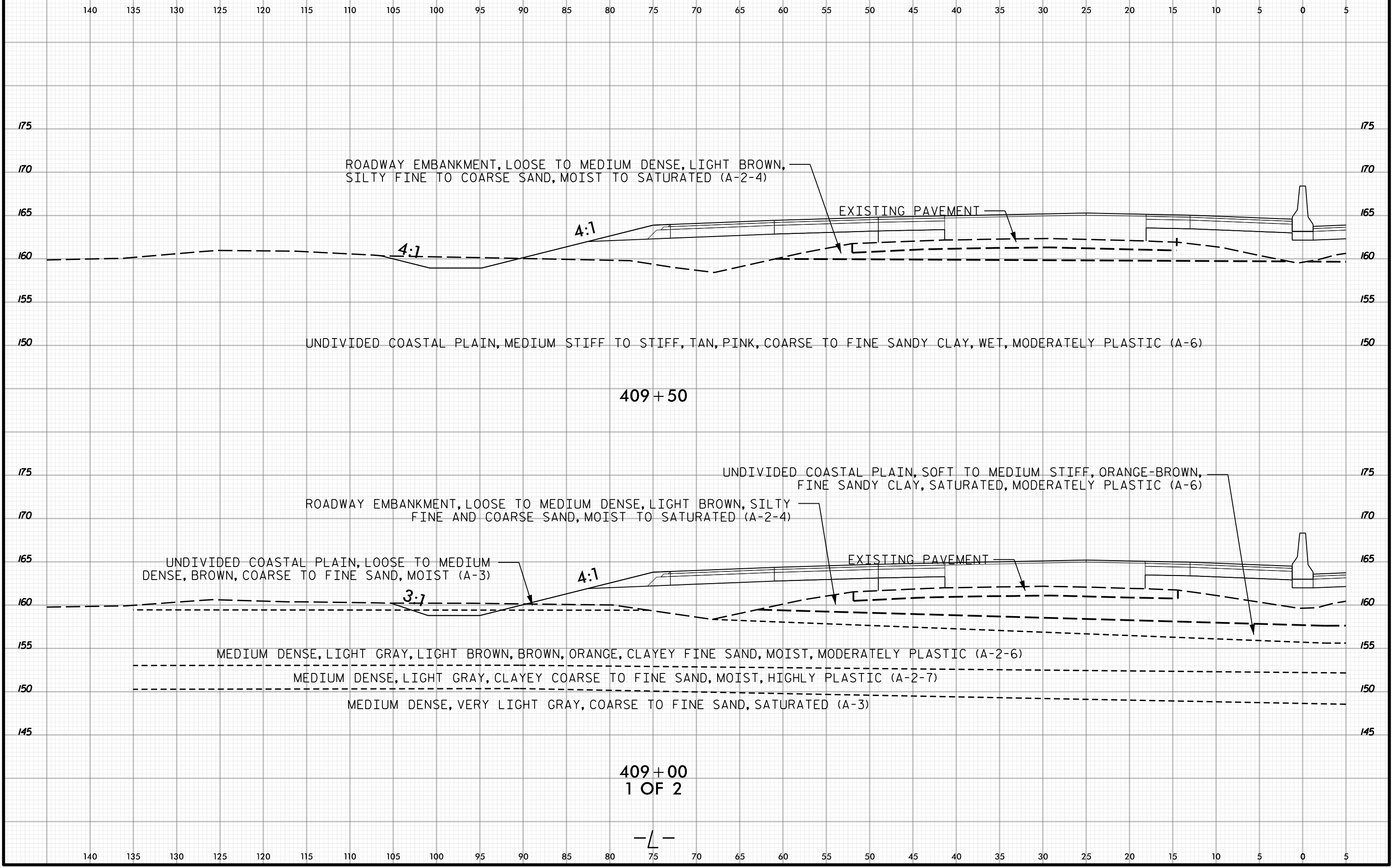

409+00  
1 OF 2

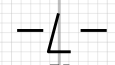

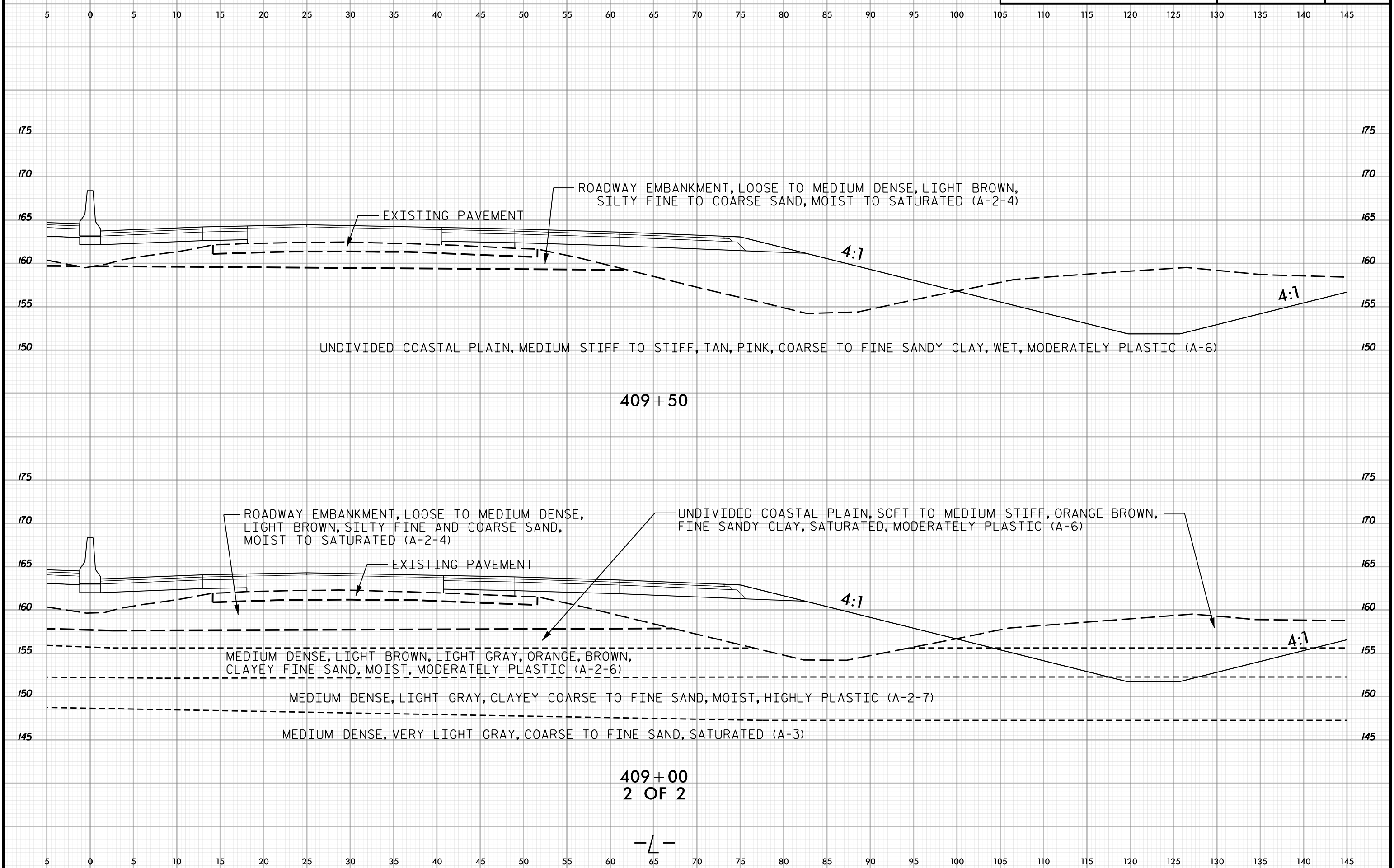



140 135 130 125 120 115 110 105 100 95 90 85 80 75 70 65 60 55 50 45 40 35 30 25 20 15 10 5 0 5

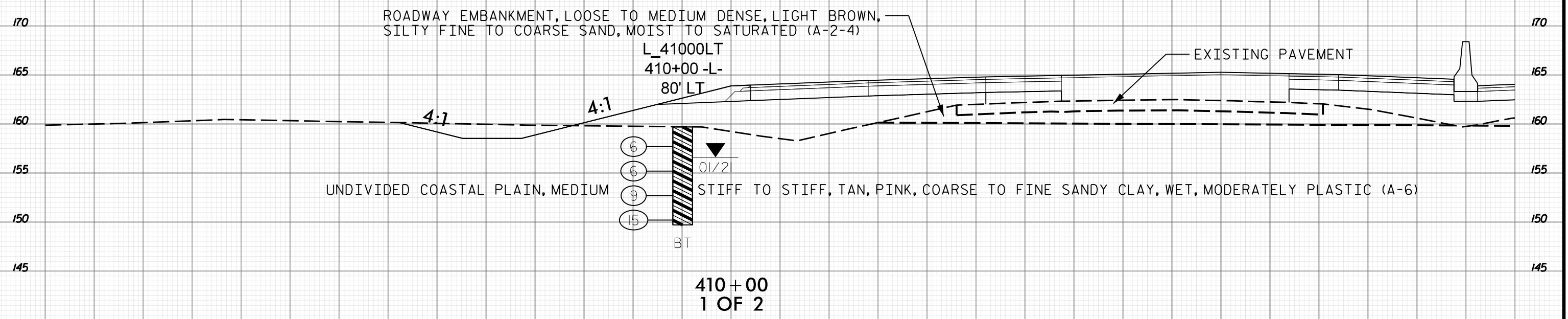
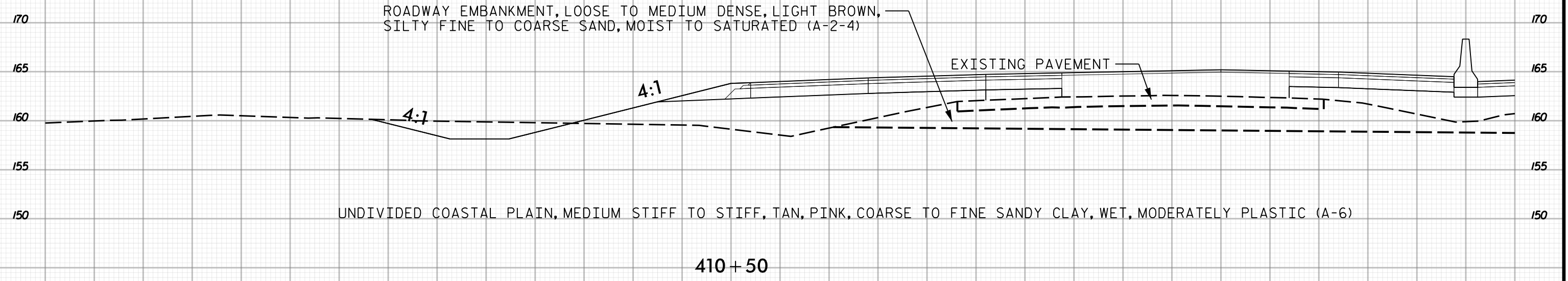

140 135 130 125 120 115 110 105 100 95 90 85 80 75 70 65 60 55 50 45 40 35 30 25 20 15 10 5 0 5

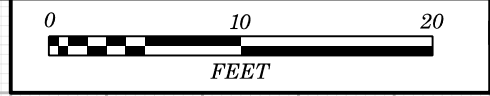

PROJ. REFERENCE NO.	SHEET NO.
I-5987A	739

5 0 5 10 15 20 25 30 35 40 45 50 55 60 65 70 75 80 85 90 95 100 105 110 115 120 125 130 135 140 145

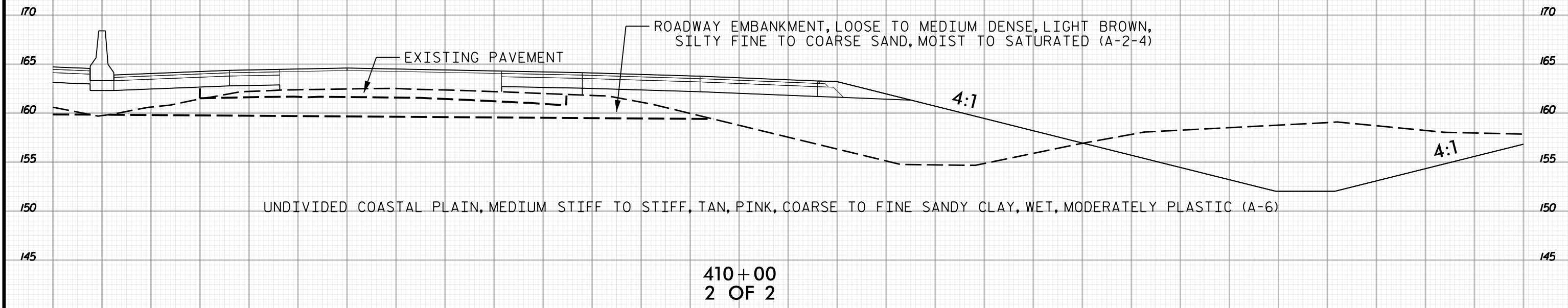
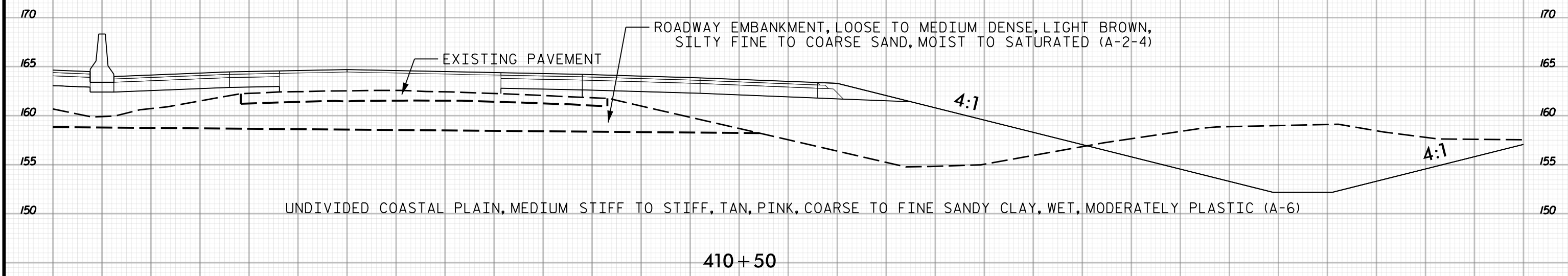

5 0 5 10 15 20 25 30 35 40 45 50 55 60 65 70 75 80 85 90 95 100 105 110 115 120 125 130 135 140 145

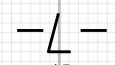



140 135 130 125 120 115 110 105 100 95 90 85 80 75 70 65 60 55 50 45 40 35 30 25 20 15 10 5 0 5

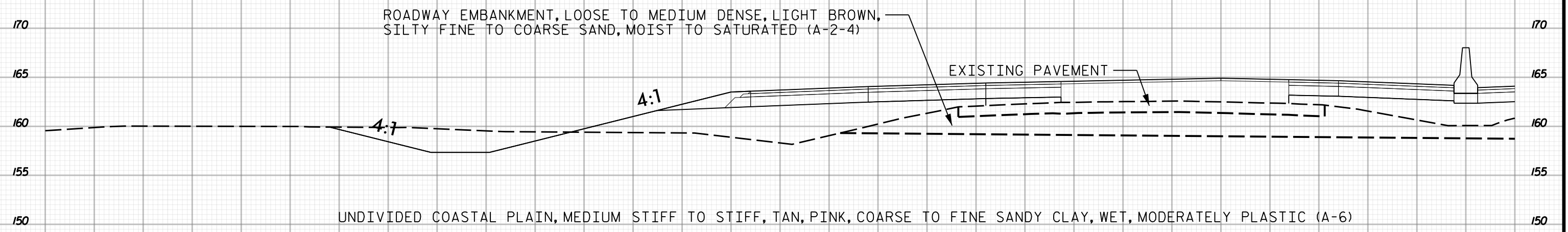

411+50

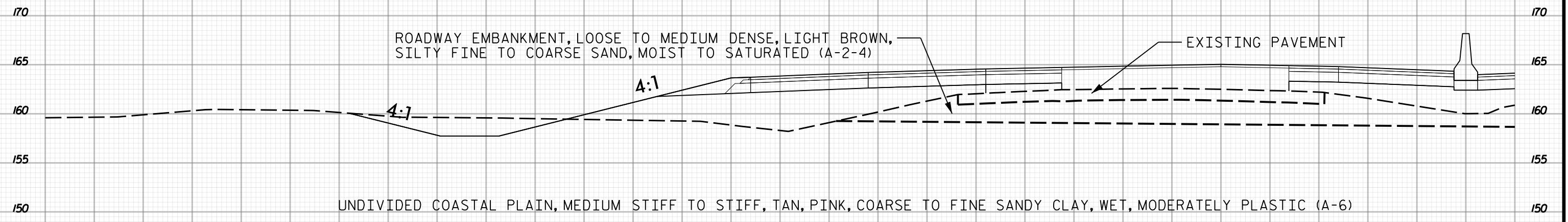

411+00  
1 OF 2

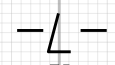

140 135 130 125 120 115 110 105 100 95 90 85 80 75 70 65 60 55 50 45 40 35 30 25 20 15 10 5 0 5



5 0 5 10 15 20 25 30 35 40 45 50 55 60 65 70 75 80 85 90 95 100 105 110 115 120 125 130 135 140 145

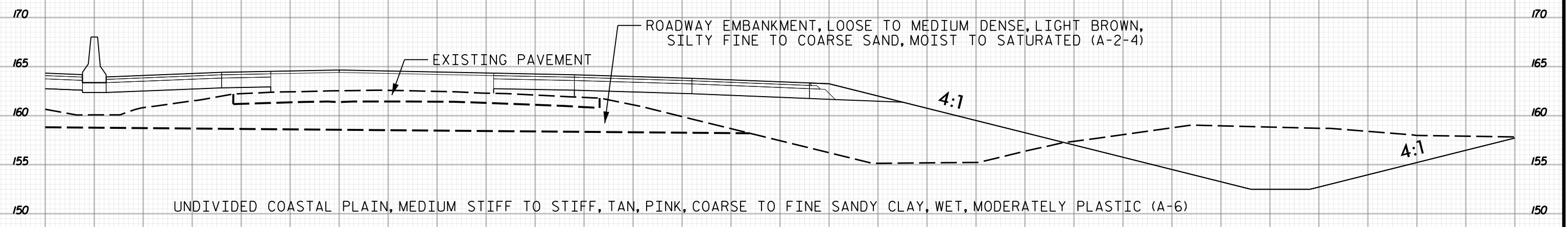

411+50

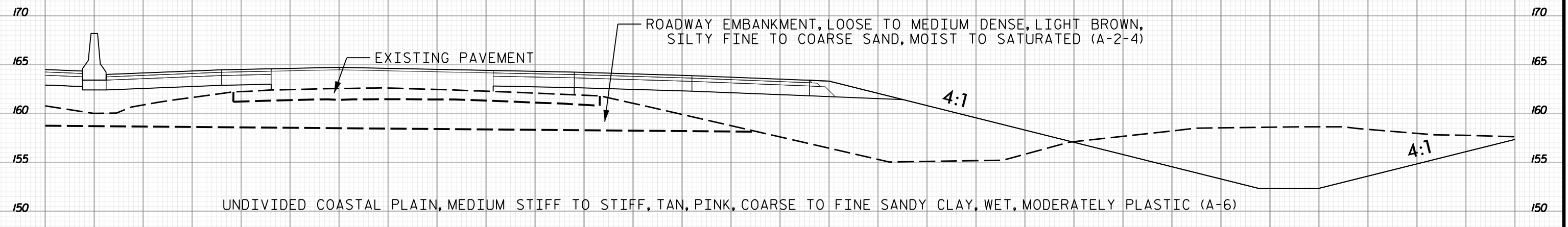

411+00  
2 OF 2

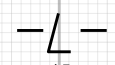

5 0 5 10 15 20 25 30 35 40 45 50 55 60 65 70 75 80 85 90 95 100 105 110 115 120 125 130 135 140 145



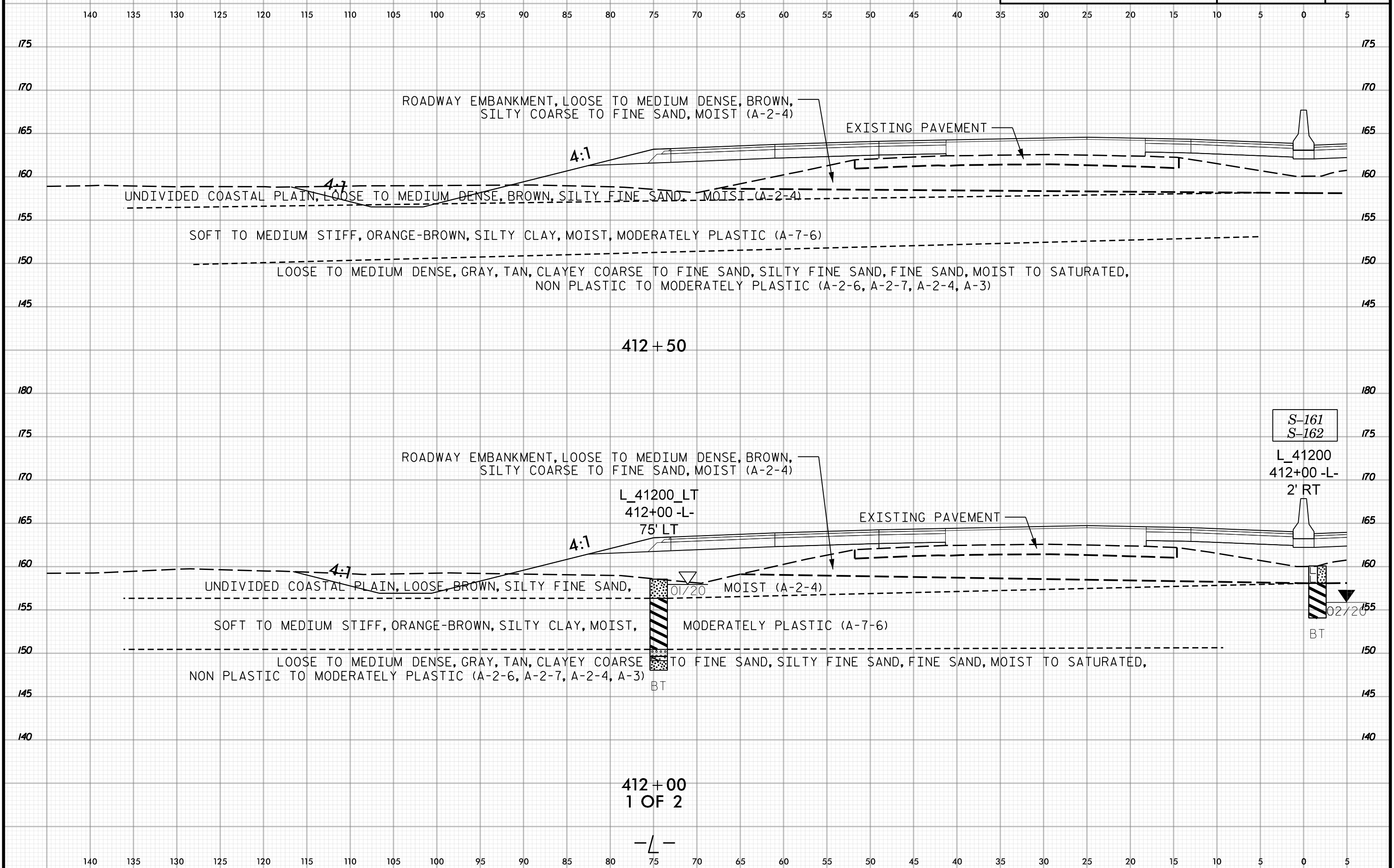

412 + 50

L\_41200\_LT  
412+00 -L-  
75' LT

S-161  
S-162

L\_41200  
412+00 -L-  
2' RT

412 + 00  
1 OF 2

-L-

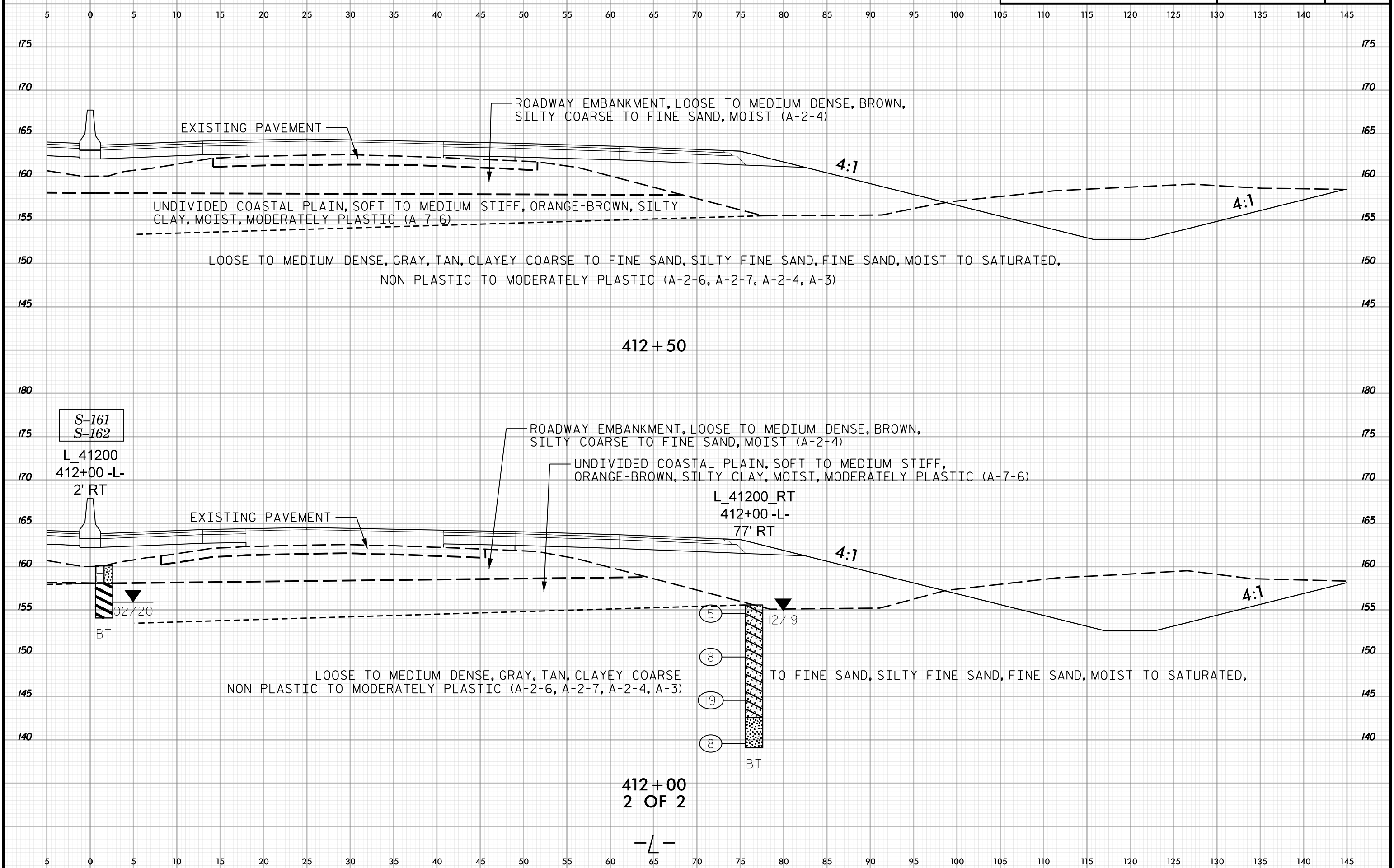
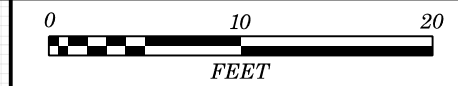

412 + 50

412 + 00  
2 OF 2

-L-

S-161  
S-162

L\_41200  
412+00 -L-  
2' RT

L\_41200\_RT  
412+00 -L-  
77' RT

02/20  
BT

5  
8  
19  
8  
BT

EXISTING PAVEMENT

ROADWAY EMBANKMENT, LOOSE TO MEDIUM DENSE, BROWN,  
SILTY COARSE TO FINE SAND, MOIST (A-2-4)

UNDIVIDED COASTAL PLAIN, SOFT TO MEDIUM STIFF, ORANGE-BROWN, SILTY  
CLAY, MOIST, MODERATELY PLASTIC (A-7-6)

LOOSE TO MEDIUM DENSE, GRAY, TAN, CLAYEY COARSE TO FINE SAND, SILTY FINE SAND, FINE SAND, MOIST TO SATURATED,  
NON PLASTIC TO MODERATELY PLASTIC (A-2-6, A-2-7, A-2-4, A-3)

ROADWAY EMBANKMENT, LOOSE TO MEDIUM DENSE, BROWN,  
SILTY COARSE TO FINE SAND, MOIST (A-2-4)

UNDIVIDED COASTAL PLAIN, SOFT TO MEDIUM STIFF,  
ORANGE-BROWN, SILTY CLAY, MOIST, MODERATELY PLASTIC (A-7-6)

EXISTING PAVEMENT

TO FINE SAND, SILTY FINE SAND, FINE SAND, MOIST TO SATURATED,

4:1

4:1

4:1

4:1



140 135 130 125 120 115 110 105 100 95 90 85 80 75 70 65 60 55 50 45 40 35 30 25 20 15 10 5 0 5

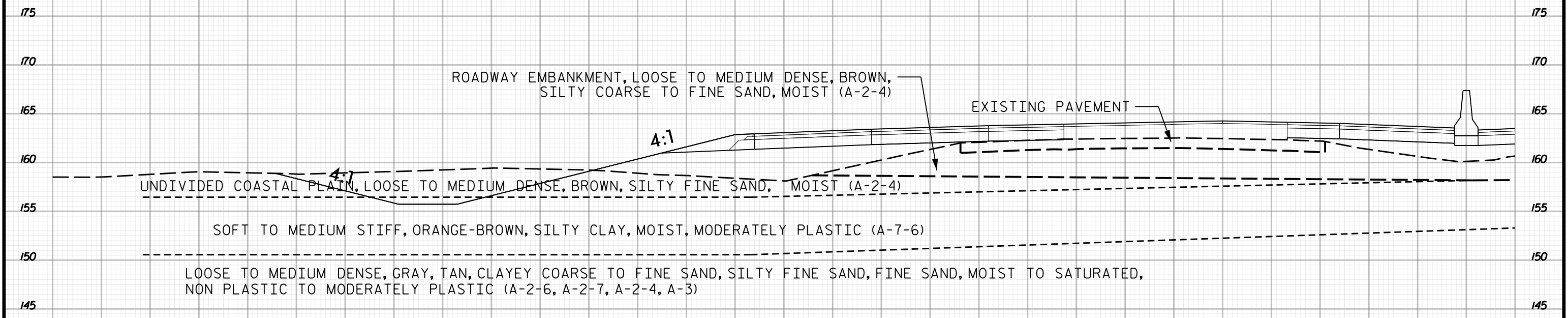

413 + 50

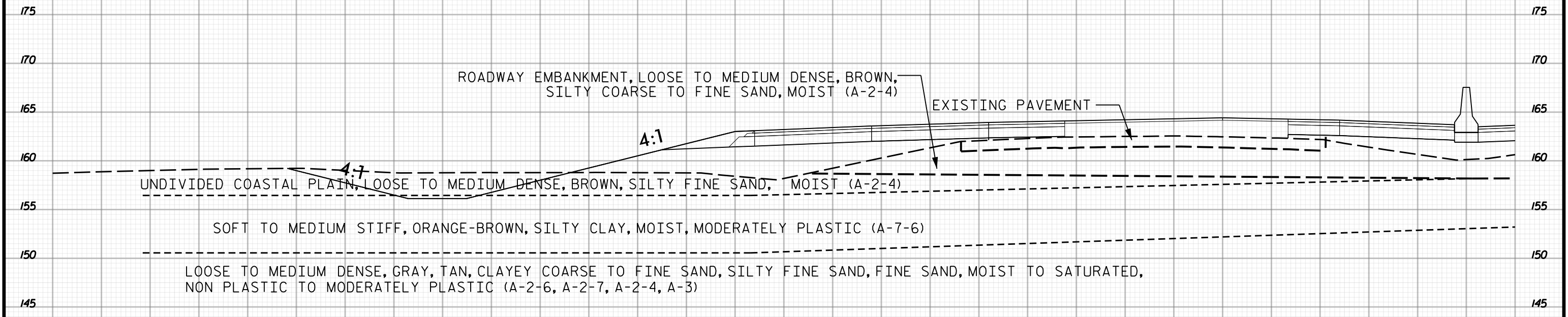

413 + 00  
1 OF 2

140 135 130 125 120 115 110 105 100 95 90 85 80 75 70 65 60 55 50 45 40 35 30 25 20 15 10 5 0 5

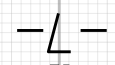

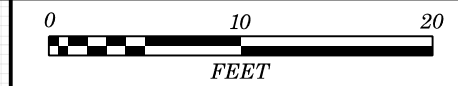

5 0 5 10 15 20 25 30 35 40 45 50 55 60 65 70 75 80 85 90 95 100 105 110 115 120 125 130 135 140 145

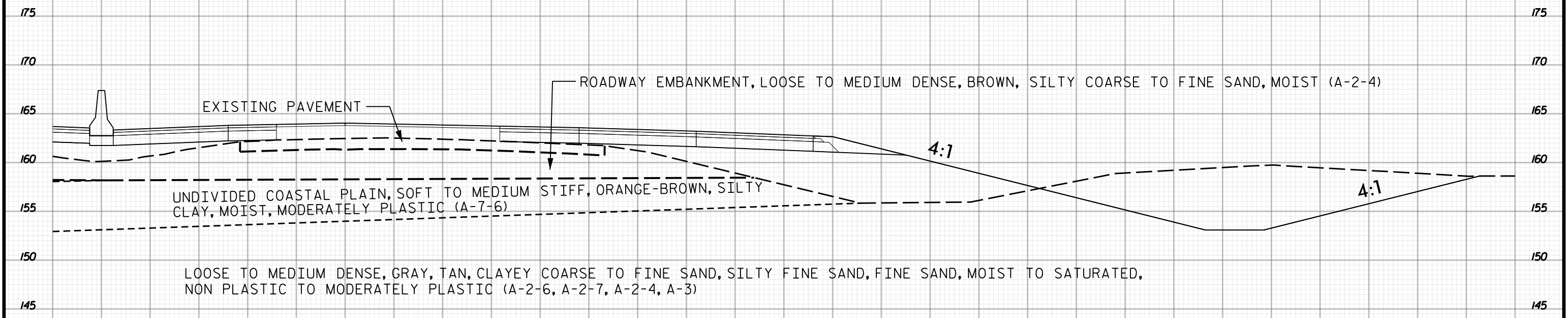

413+50

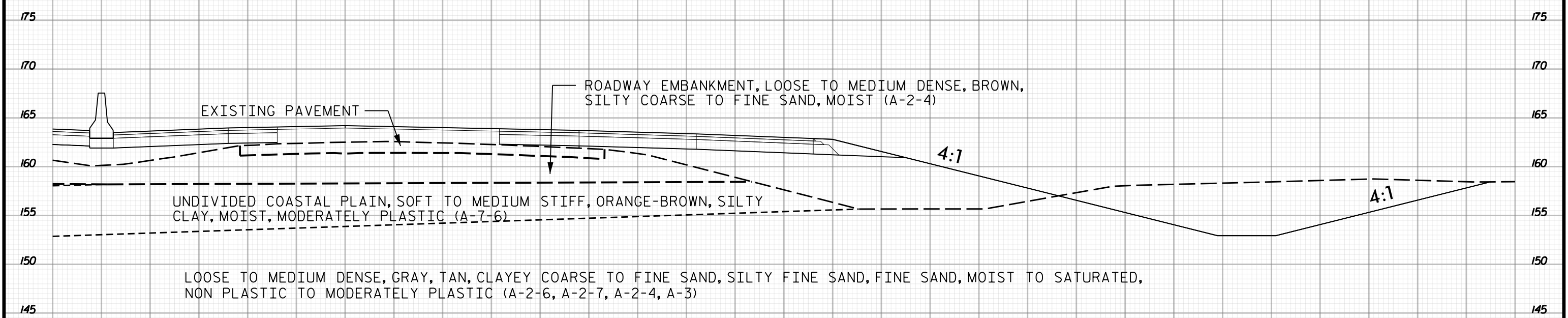

413+00  
2 OF 2

5 0 5 10 15 20 25 30 35 40 45 50 55 60 65 70 75 80 85 90 95 100 105 110 115 120 125 130 135 140 145

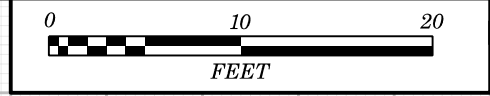

PROJ. REFERENCE NO.	SHEET NO.
I-5987A	746

140 135 130 125 120 115 110 105 100 95 90 85 80 75 70 65 60 55 50 45 40 35 30 25 20 15 10 5 0 5

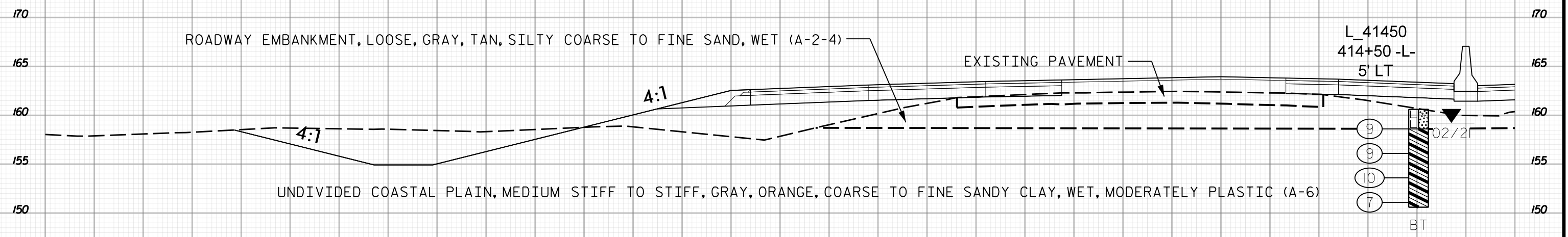

414 + 50

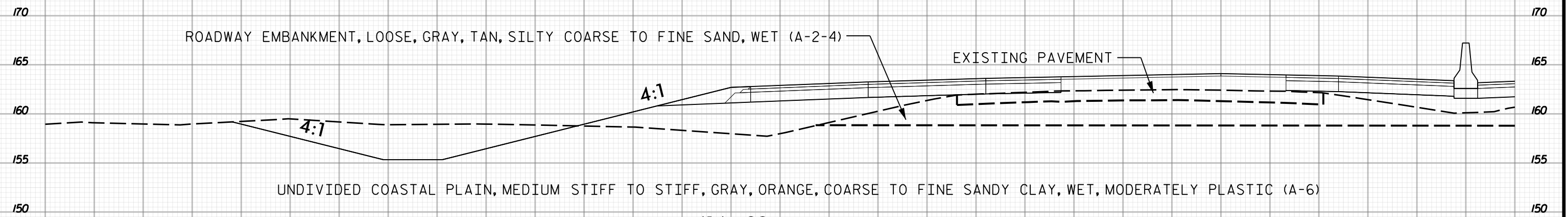

414 + 00  
1 OF 2

-L-

140 135 130 125 120 115 110 105 100 95 90 85 80 75 70 65 60 55 50 45 40 35 30 25 20 15 10 5 0 5



PROJ. REFERENCE NO.	SHEET NO.
I-5987A	747

5 0 5 10 15 20 25 30 35 40 45 50 55 60 65 70 75 80 85 90 95 100 105 110 115 120 125 130 135 140 145

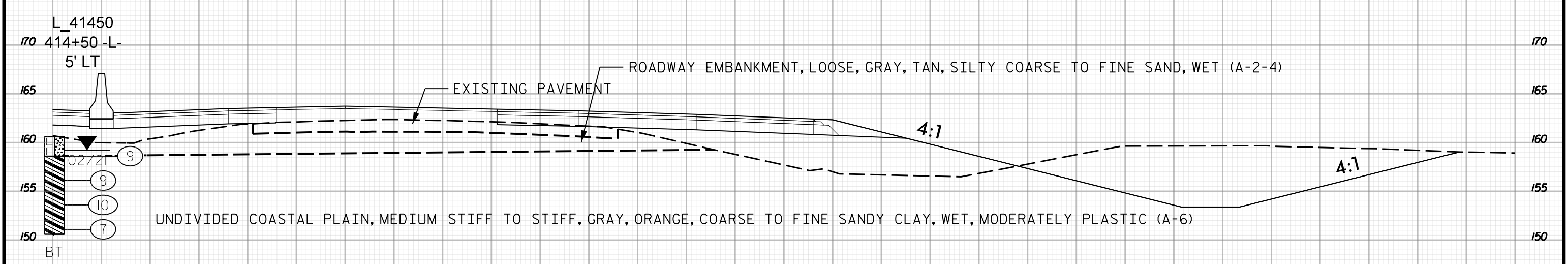

414 + 50

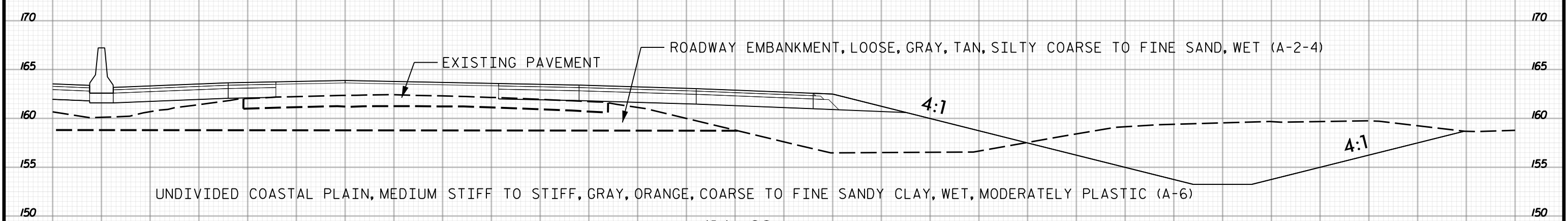

414 + 00  
2 OF 2

—L—

5 0 5 10 15 20 25 30 35 40 45 50 55 60 65 70 75 80 85 90 95 100 105 110 115 120 125 130 135 140 145

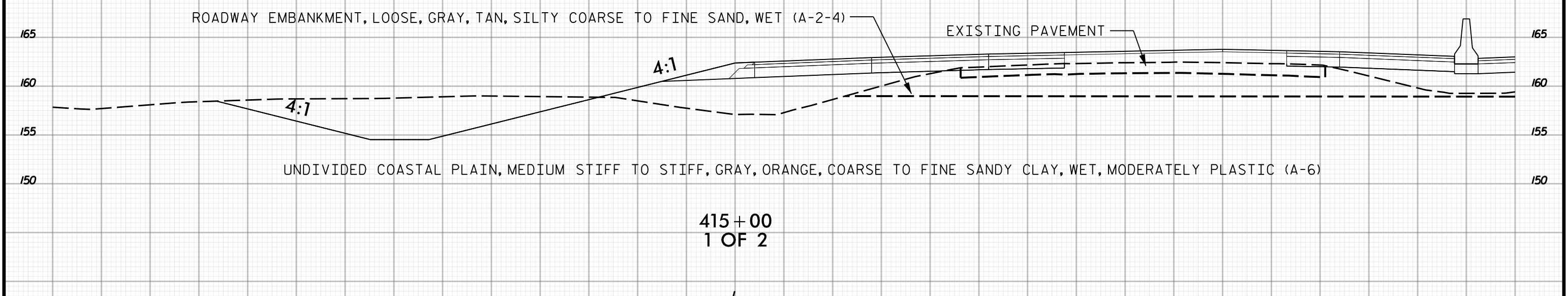
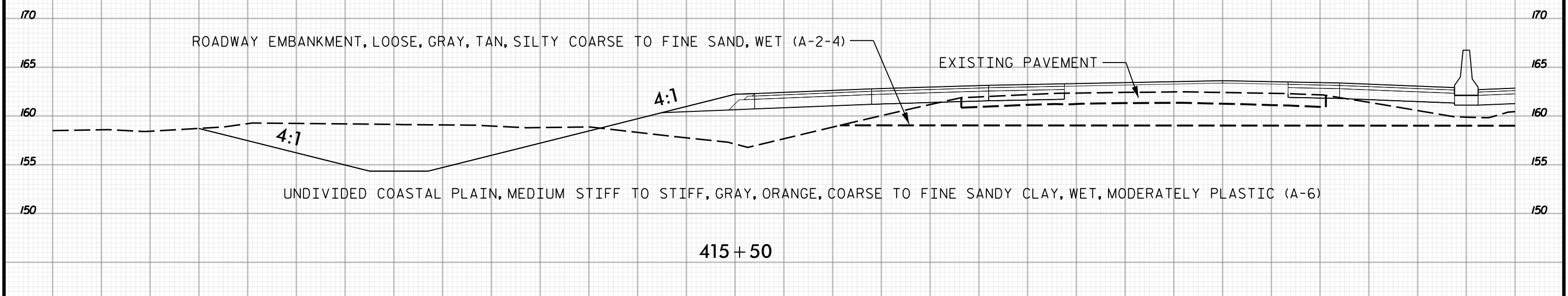
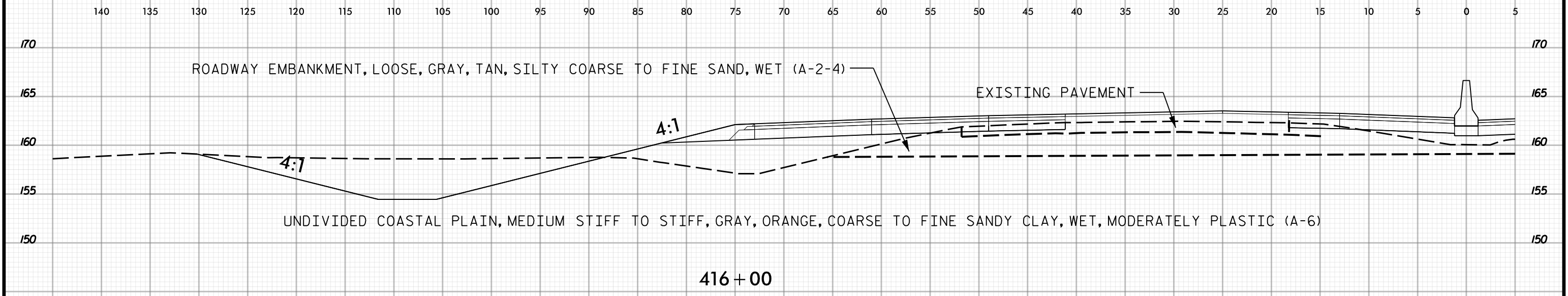

415 + 00  
1 OF 2

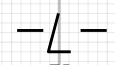

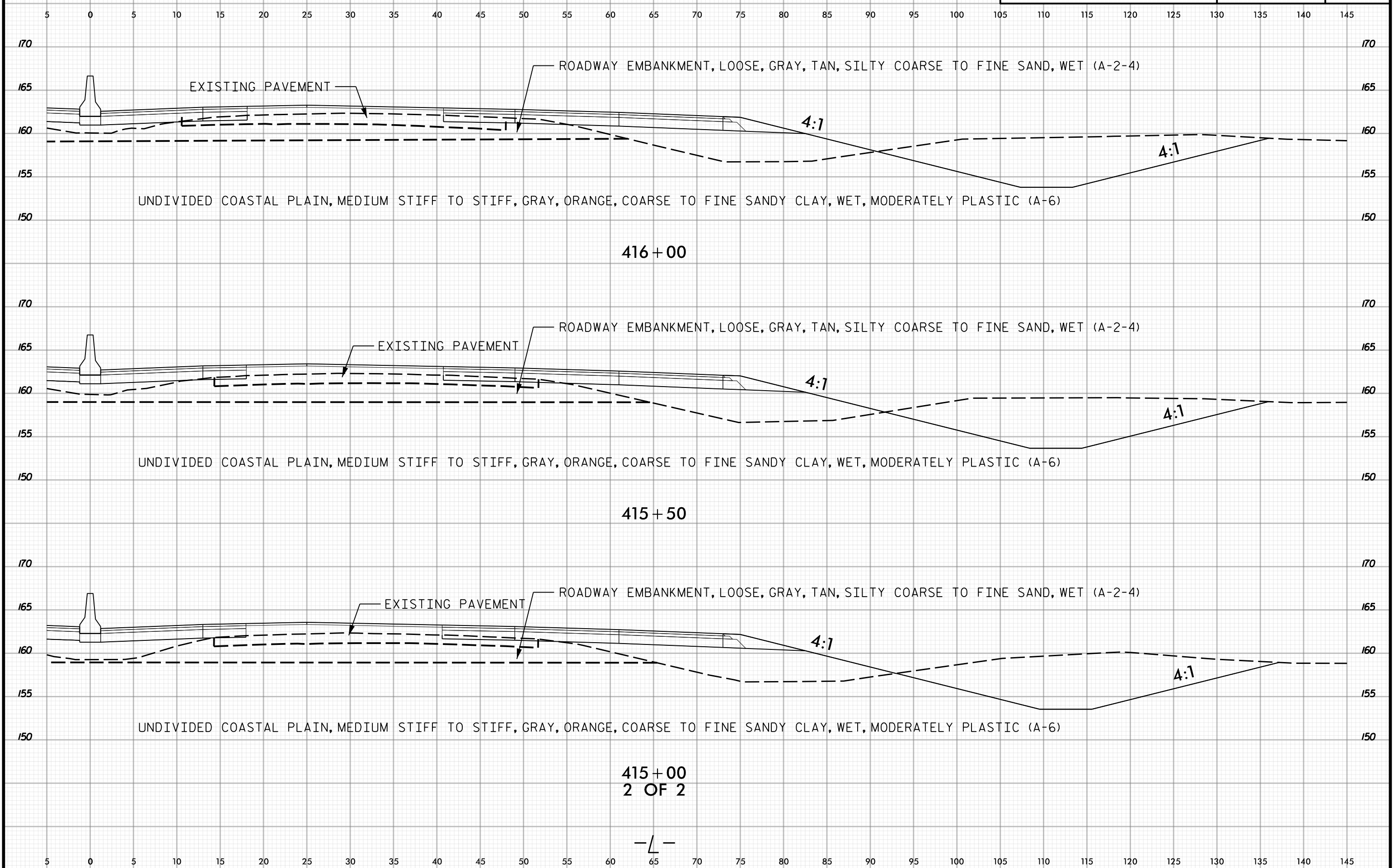





140 135 130 125 120 115 110 105 100 95 90 85 80 75 70 65 60 55 50 45 40 35 30 25 20 15 10 5 0 5

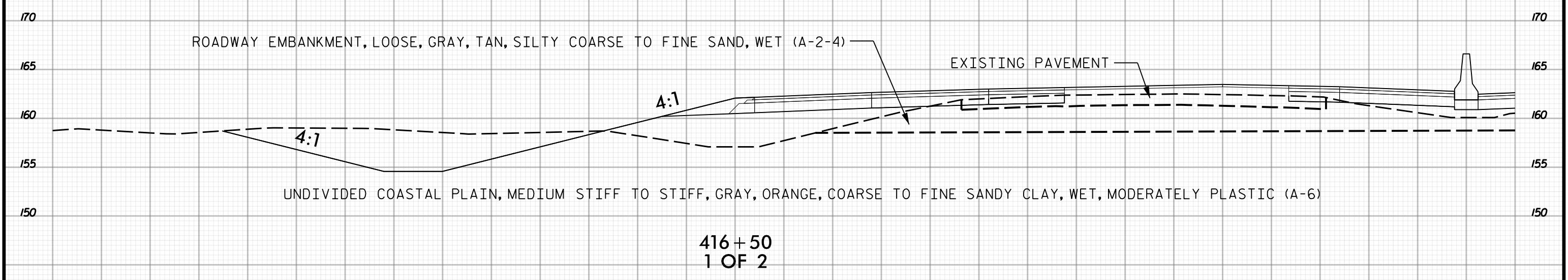
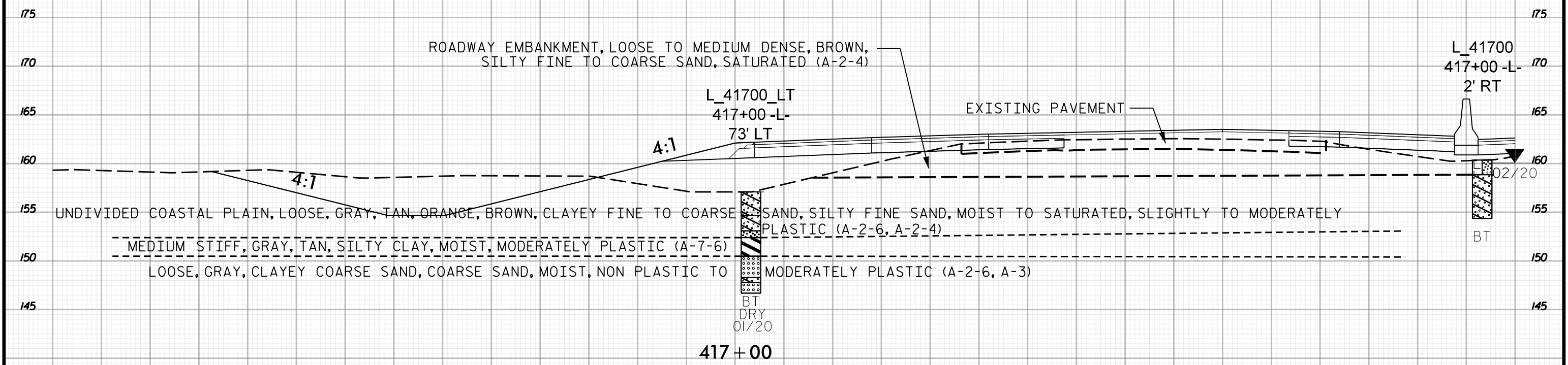

140 135 130 125 120 115 110 105 100 95 90 85 80 75 70 65 60 55 50 45 40 35 30 25 20 15 10 5 0 5

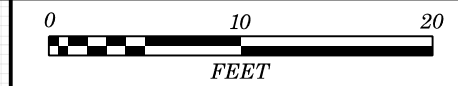

5 0 5 10 15 20 25 30 35 40 45 50 55 60 65 70 75 80 85 90 95 100 105 110 115 120 125 130 135 140 145

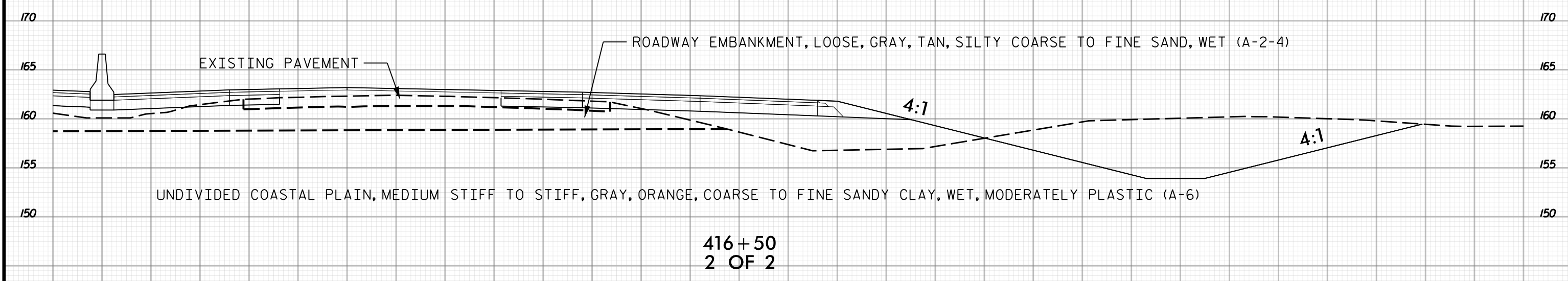
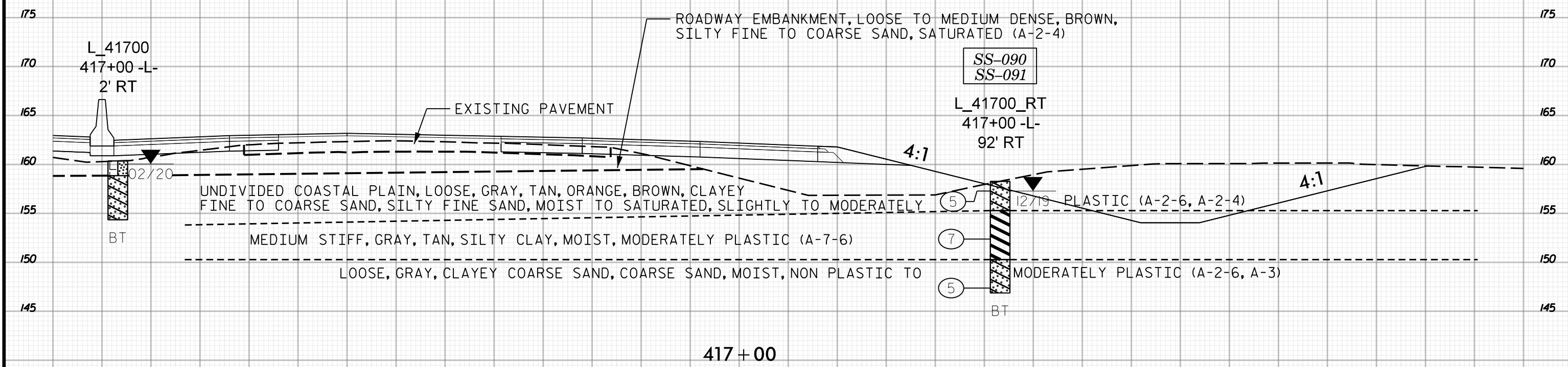

5 0 5 10 15 20 25 30 35 40 45 50 55 60 65 70 75 80 85 90 95 100 105 110 115 120 125 130 135 140 145



140 135 130 125 120 115 110 105 100 95 90 85 80 75 70 65 60 55 50 45 40 35 30 25 20 15 10 5 0 5

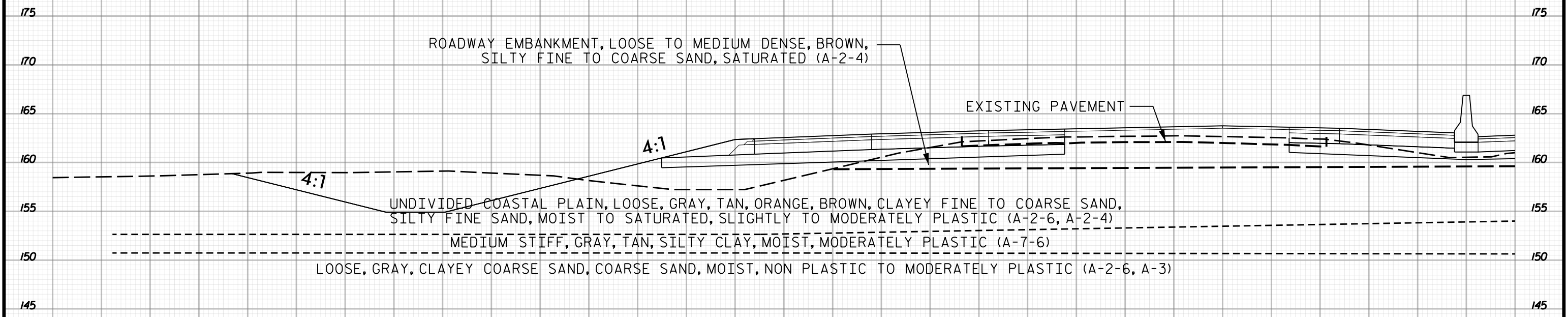

418 + 00

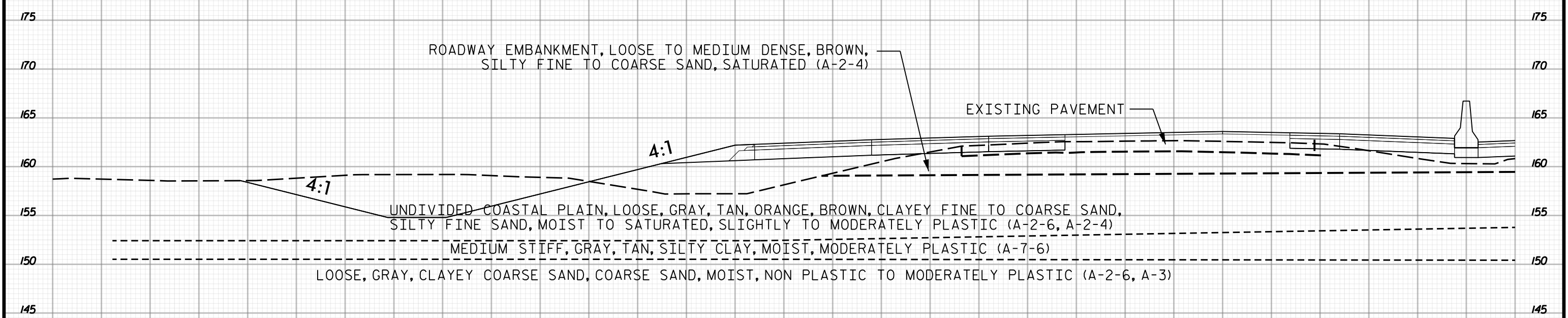

417 + 50  
1 OF 2

140 135 130 125 120 115 110 105 100 95 90 85 80 75 70 65 60 55 50 45 40 35 30 25 20 15 10 5 0 5



5 0 5 10 15 20 25 30 35 40 45 50 55 60 65 70 75 80 85 90 95 100 105 110 115 120 125 130 135 140 145

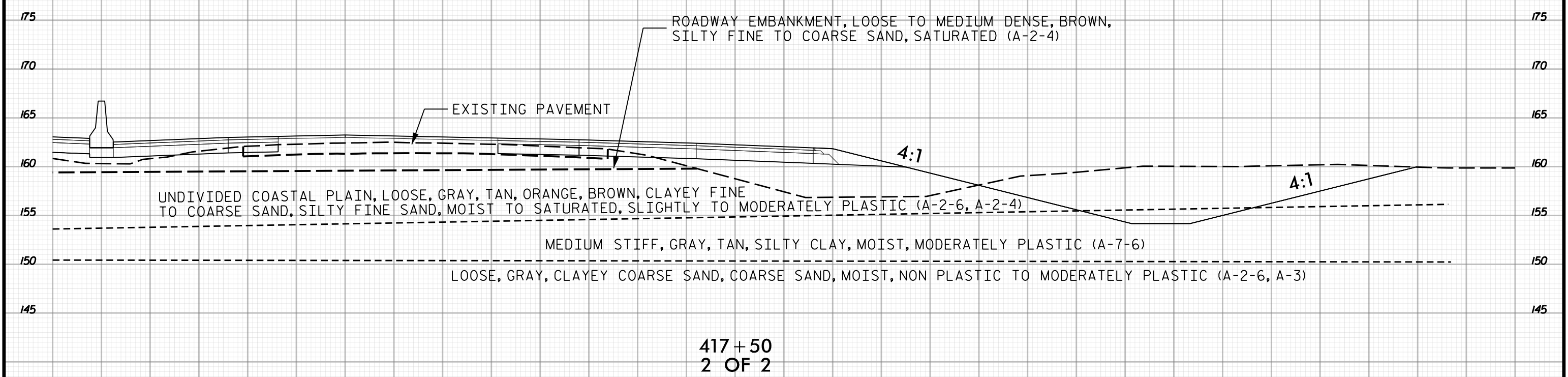
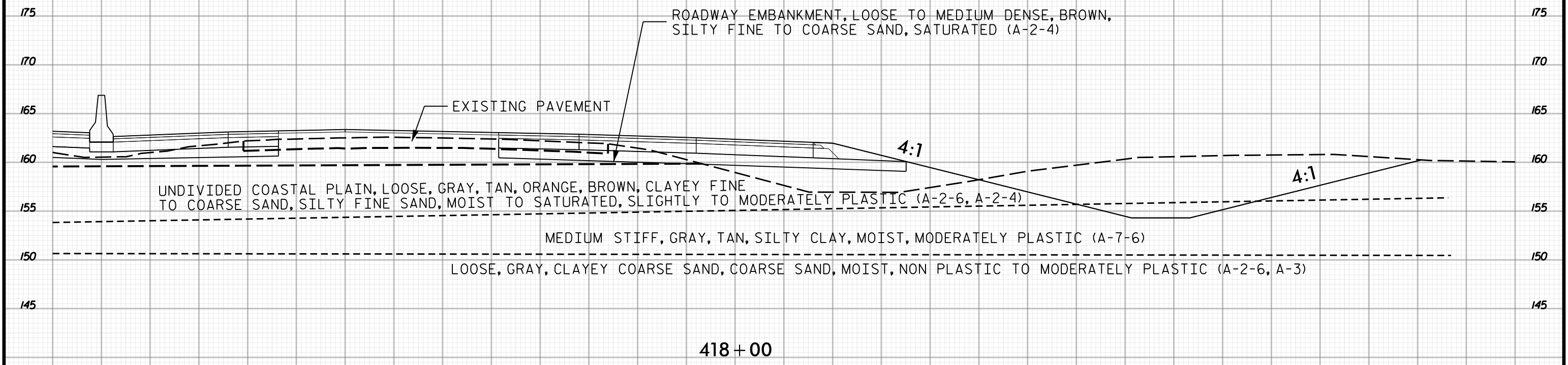

5 0 5 10 15 20 25 30 35 40 45 50 55 60 65 70 75 80 85 90 95 100 105 110 115 120 125 130 135 140 145



140 135 130 125 120 115 110 105 100 95 90 85 80 75 70 65 60 55 50 45 40 35 30 25 20 15 10 5 0 5

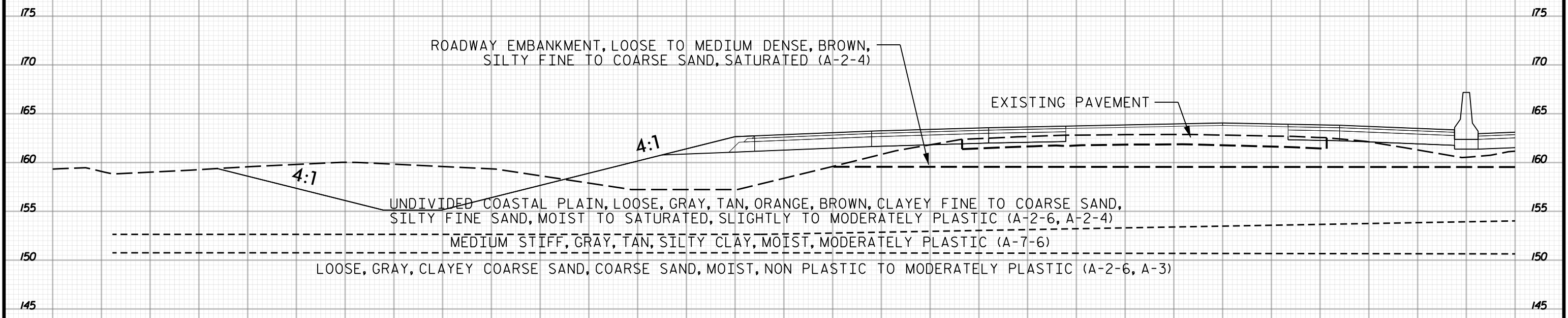

419 + 00

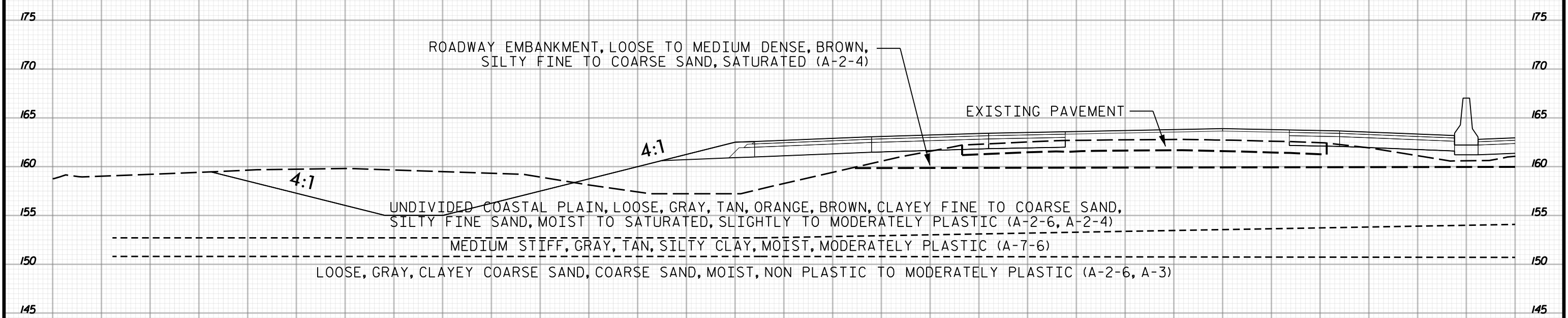

418 + 50  
1 OF 2

140 135 130 125 120 115 110 105 100 95 90 85 80 75 70 65 60 55 50 45 40 35 30 25 20 15 10 5 0 5

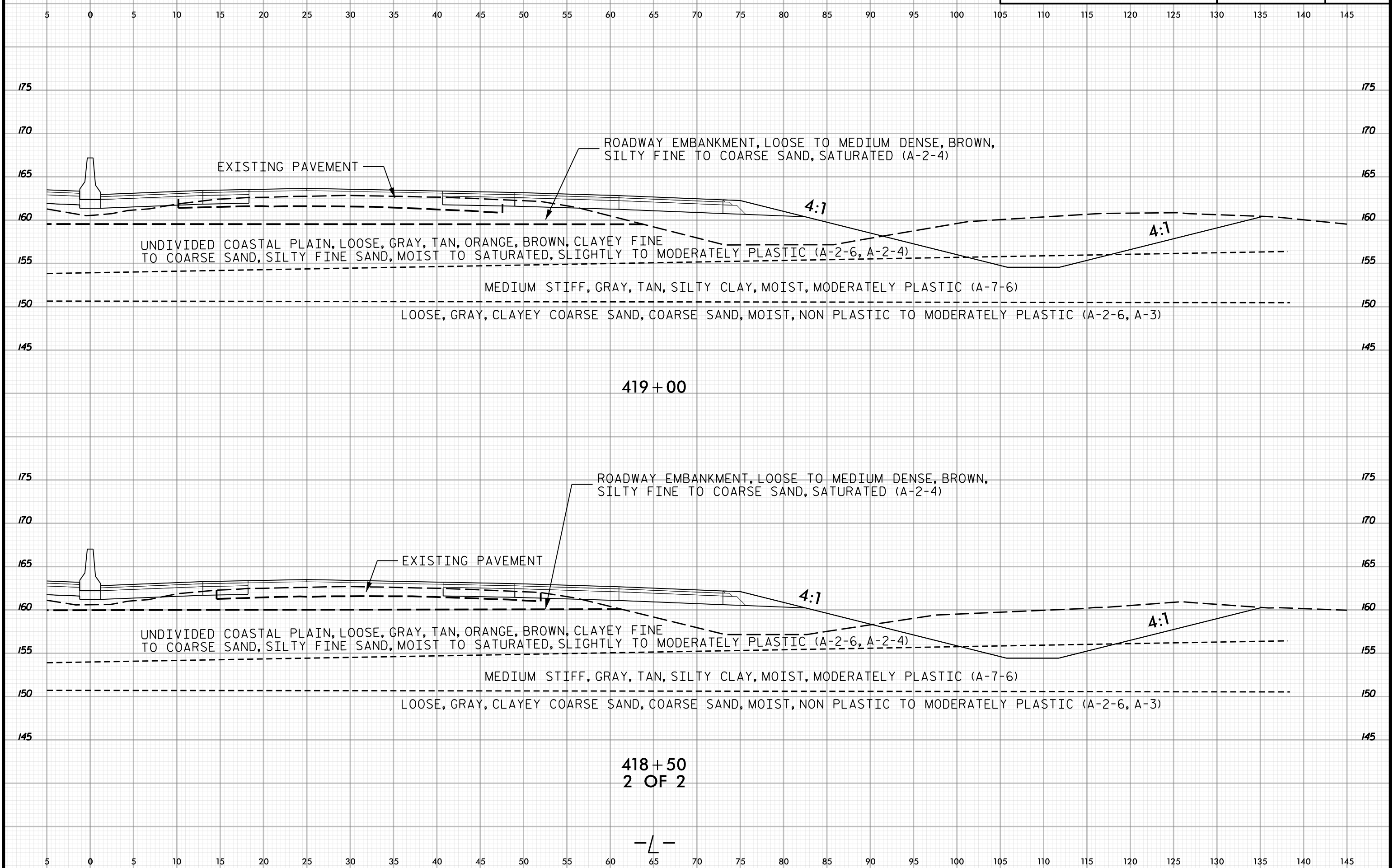

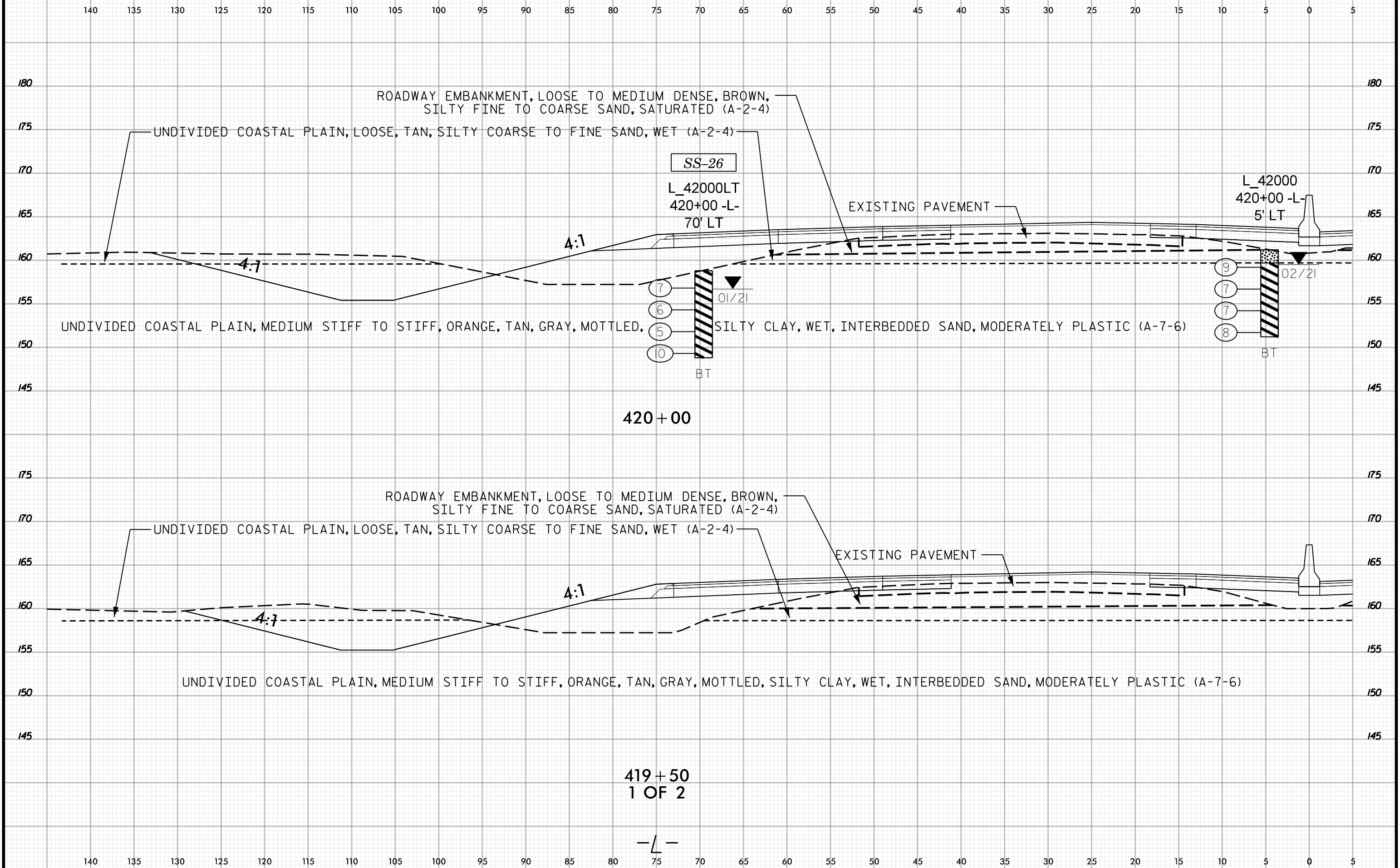
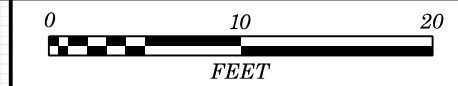

420+00

419+50  
1 OF 2

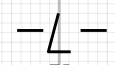

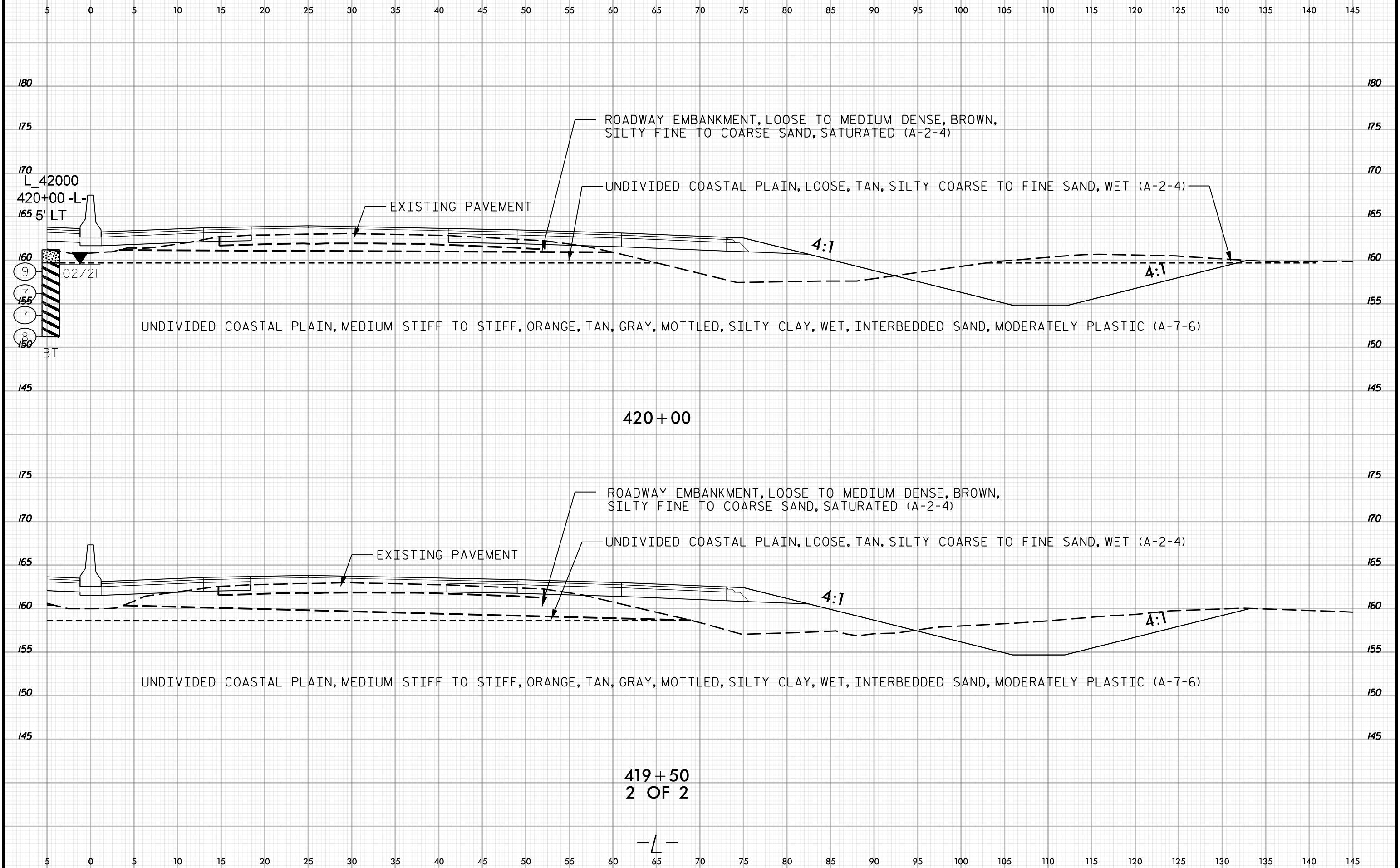
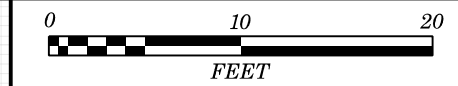

180  
175  
170  
165  
160  
155  
150  
145

180  
175  
170  
165  
160  
155  
150  
145

180  
175  
170  
165  
160  
155  
150  
145

180  
175  
170  
165  
160  
155  
150  
145

5 0 5 10 15 20 25 30 35 40 45 50 55 60 65 70 75 80 85 90 95 100 105 110 115 120 125 130 135 140 145

5 0 5 10 15 20 25 30 35 40 45 50 55 60 65 70 75 80 85 90 95 100 105 110 115 120 125 130 135 140 145

L\_42000  
420+00 -L-  
165.5' LT

9  
7  
155  
7  
8  
150

419+50  
2 OF 2

-L-



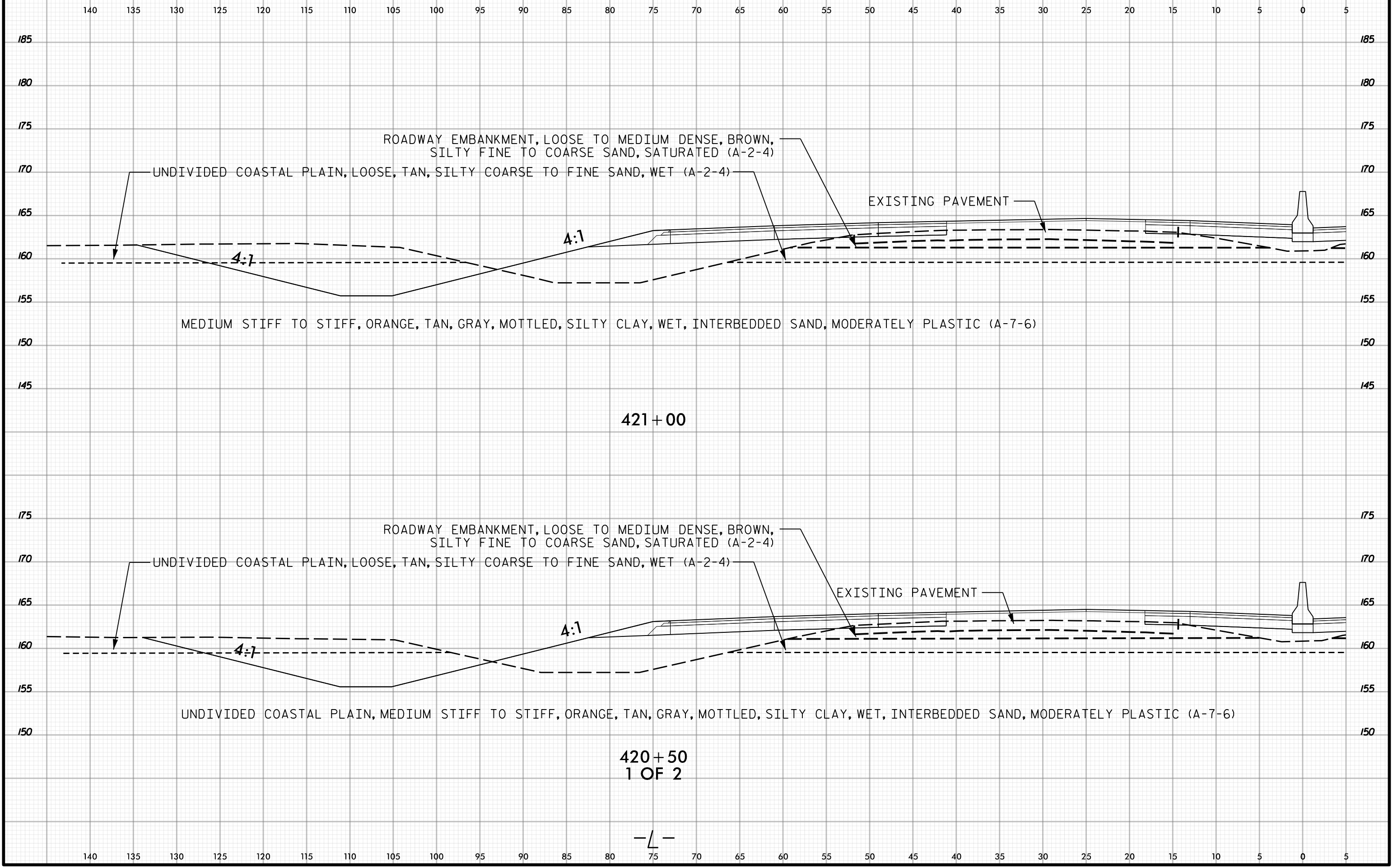

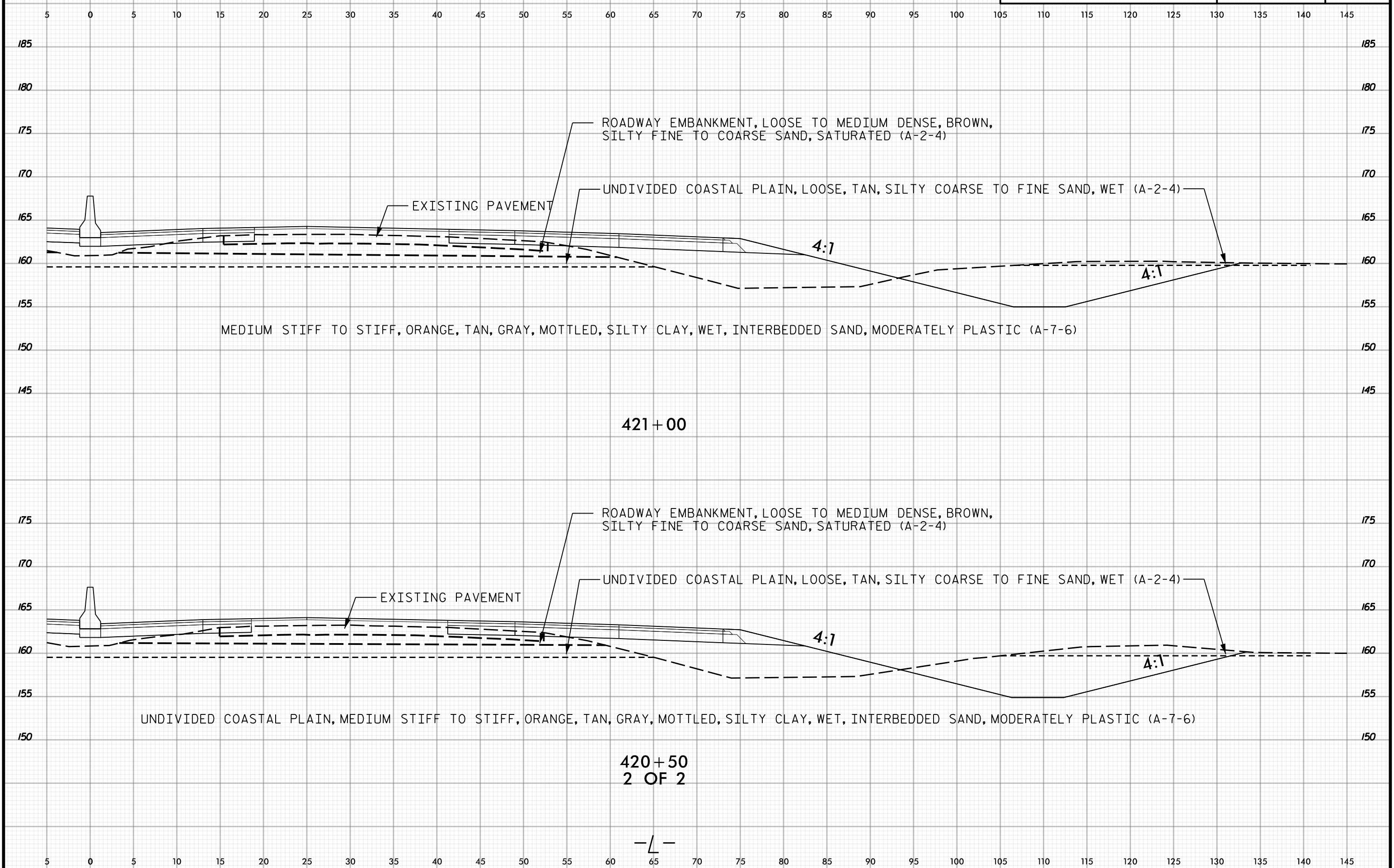

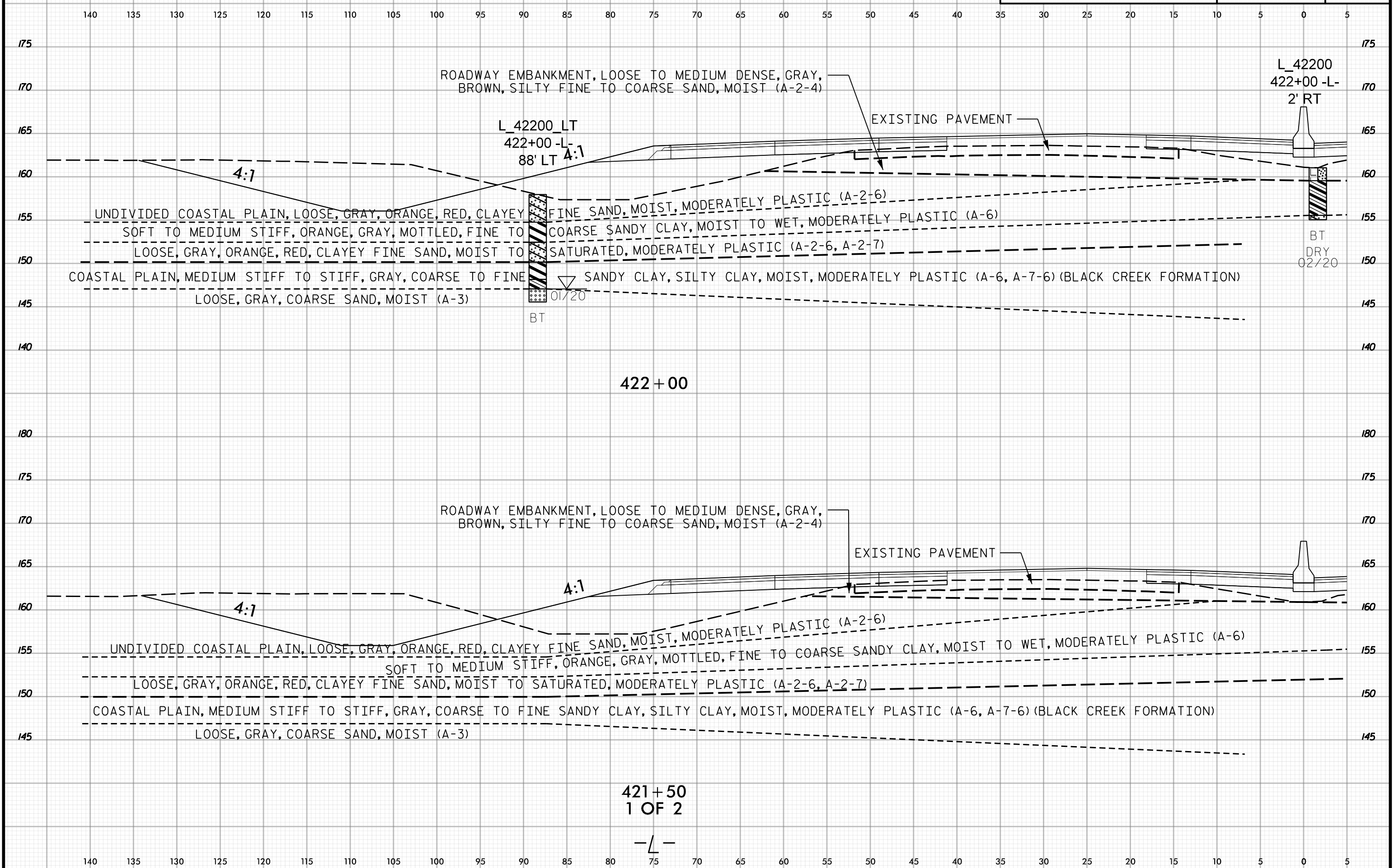

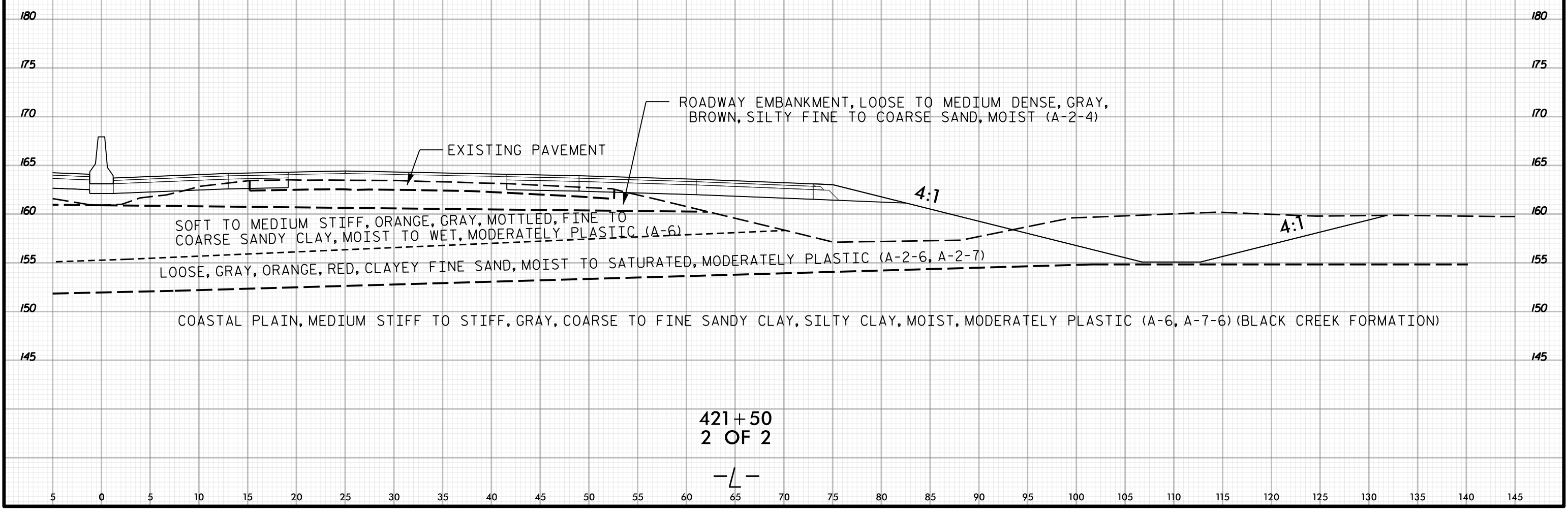
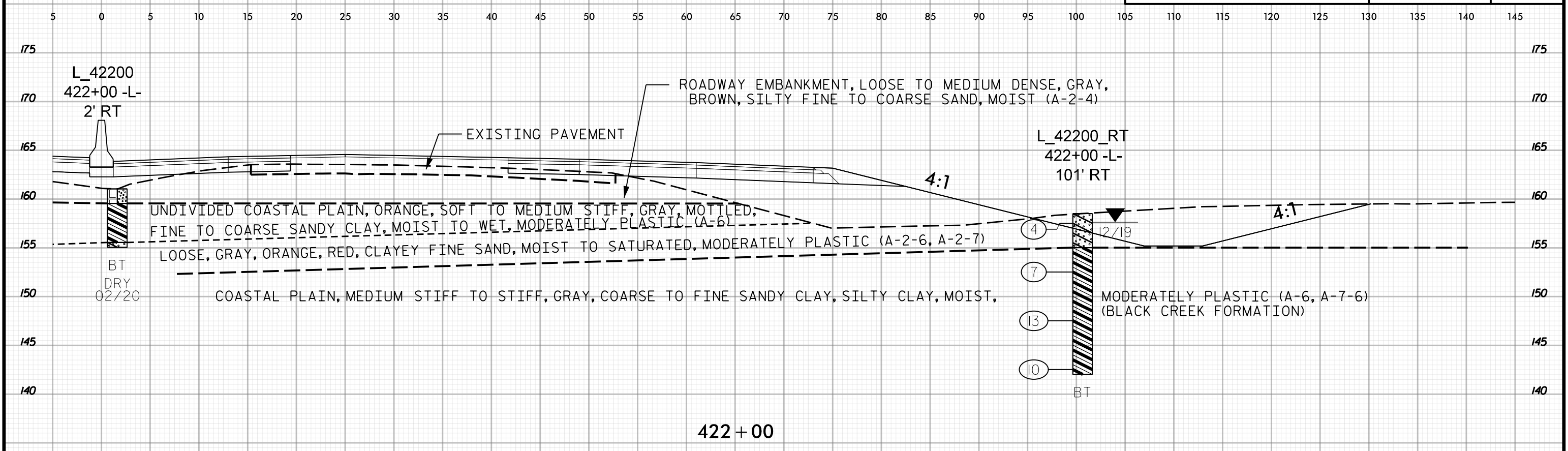
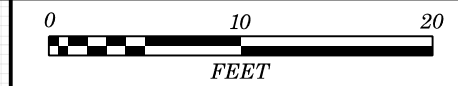

421+50  
2 OF 2

-L-



140 135 130 125 120 115 110 105 100 95 90 85 80 75 70 65 60 55 50 45 40 35 30 25 20 15 10 5 0 5

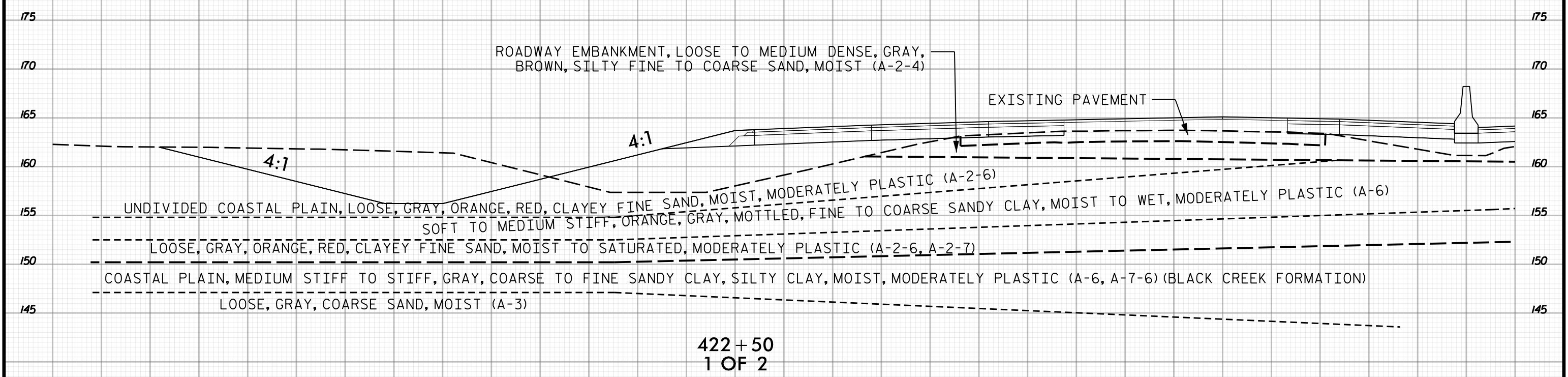
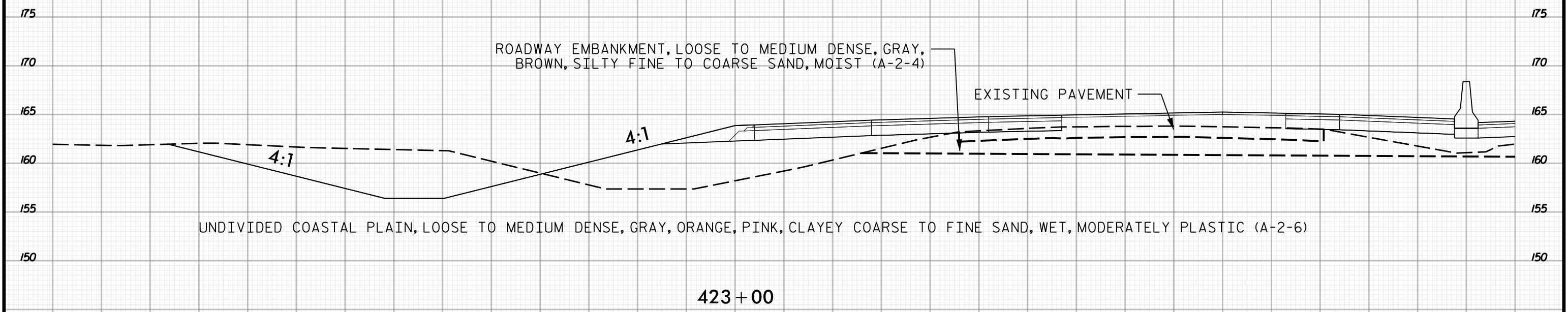

140 135 130 125 120 115 110 105 100 95 90 85 80 75 70 65 60 55 50 45 40 35 30 25 20 15 10 5 0 5



5 0 5 10 15 20 25 30 35 40 45 50 55 60 65 70 75 80 85 90 95 100 105 110 115 120 125 130 135 140 145

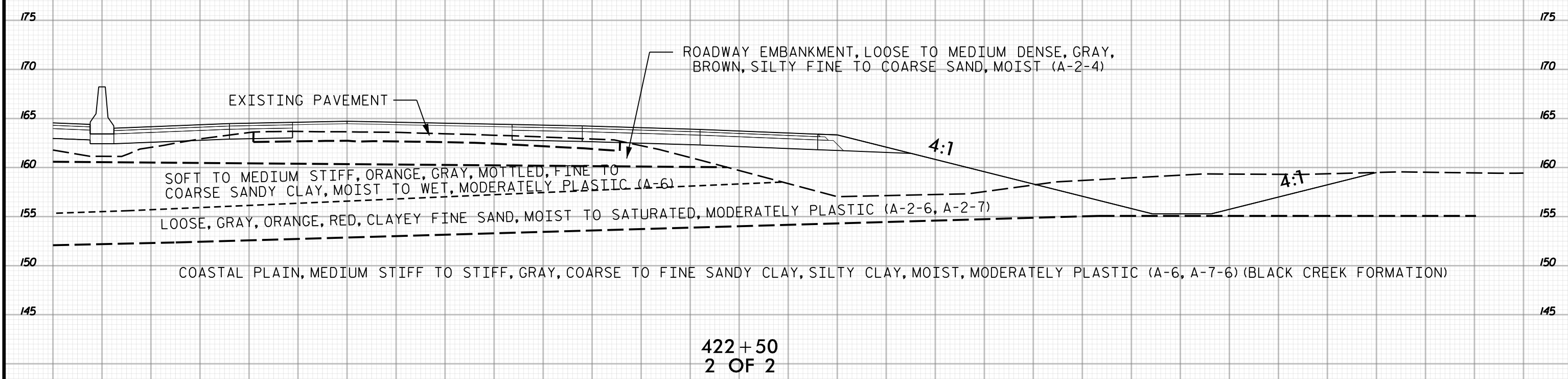
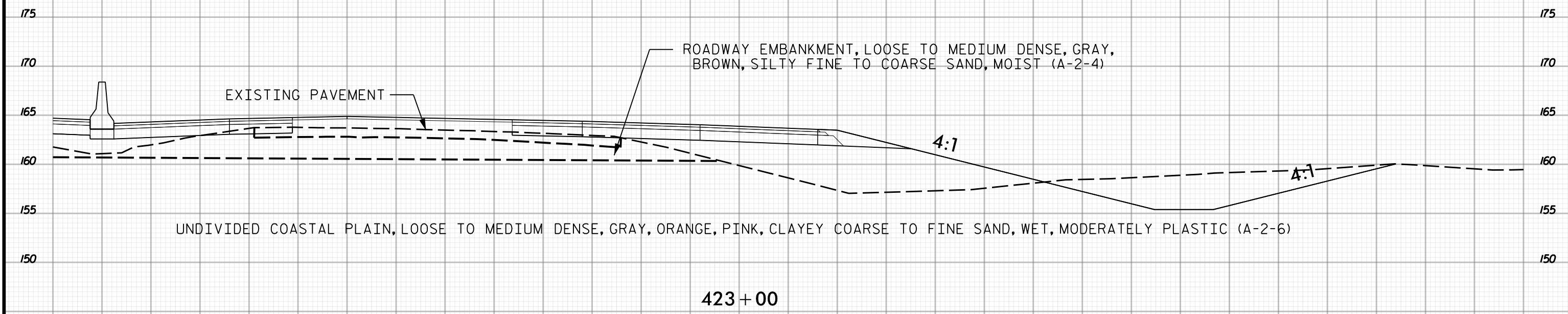

5 0 5 10 15 20 25 30 35 40 45 50 55 60 65 70 75 80 85 90 95 100 105 110 115 120 125 130 135 140 145

-L-



PROJ. REFERENCE NO.	SHEET NO.
I-5987A	764

140 135 130 125 120 115 110 105 100 95 90 85 80 75 70 65 60 55 50 45 40 35 30 25 20 15 10 5 0 5

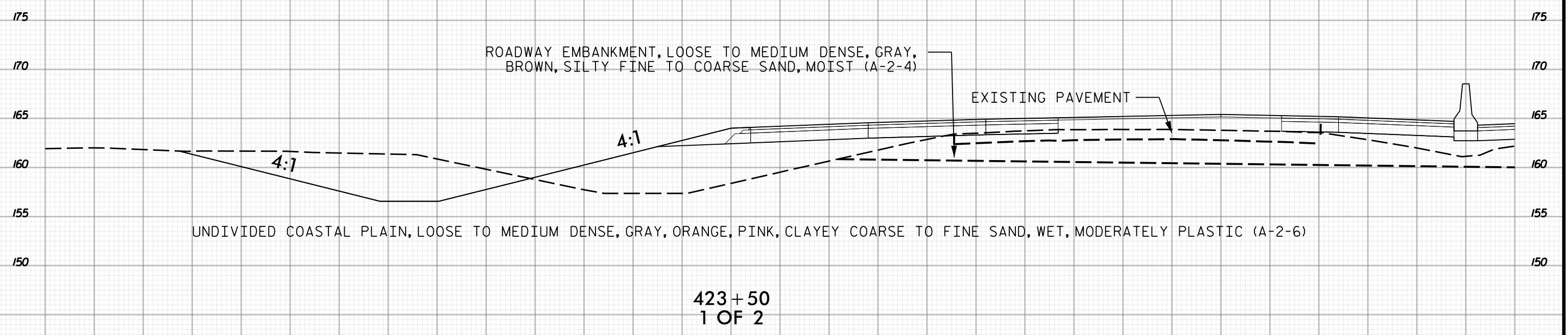
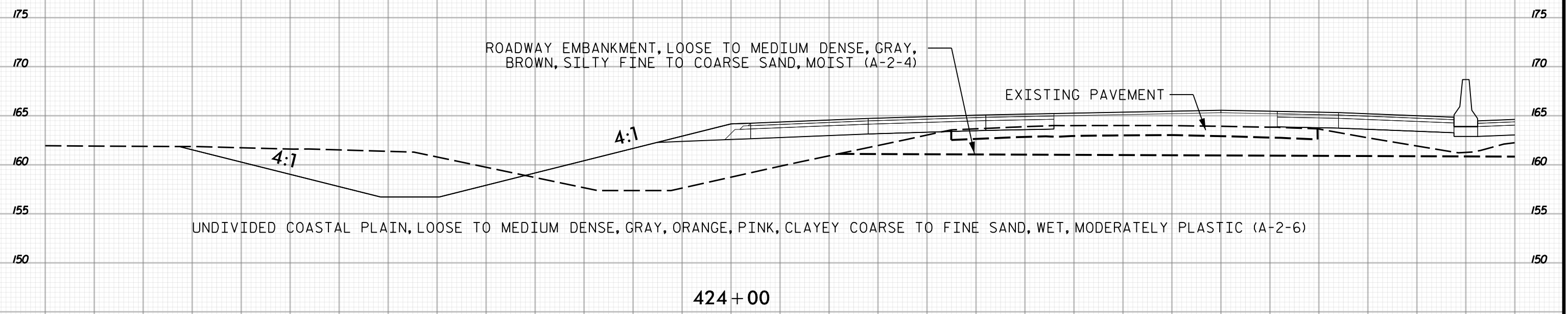

140 135 130 125 120 115 110 105 100 95 90 85 80 75 70 65 60 55 50 45 40 35 30 25 20 15 10 5 0 5

—L—



5 0 5 10 15 20 25 30 35 40 45 50 55 60 65 70 75 80 85 90 95 100 105 110 115 120 125 130 135 140 145

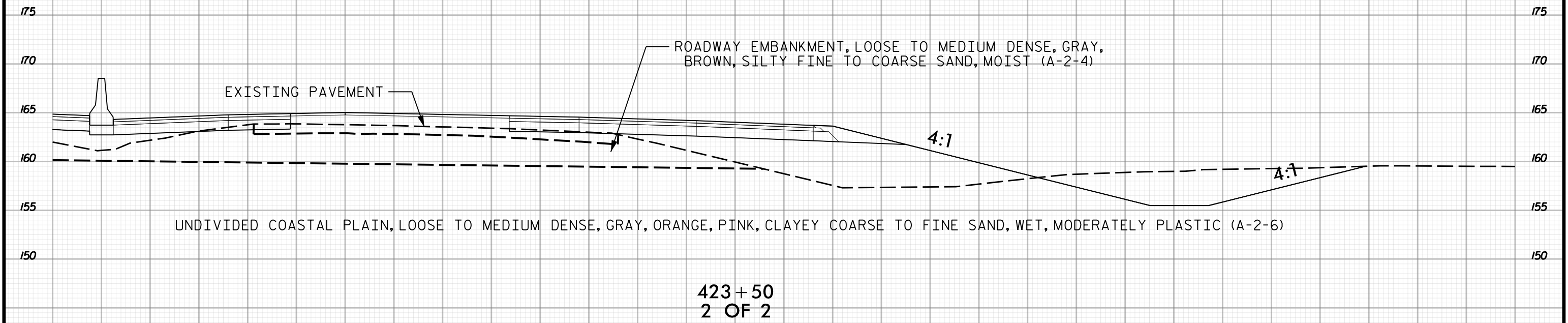
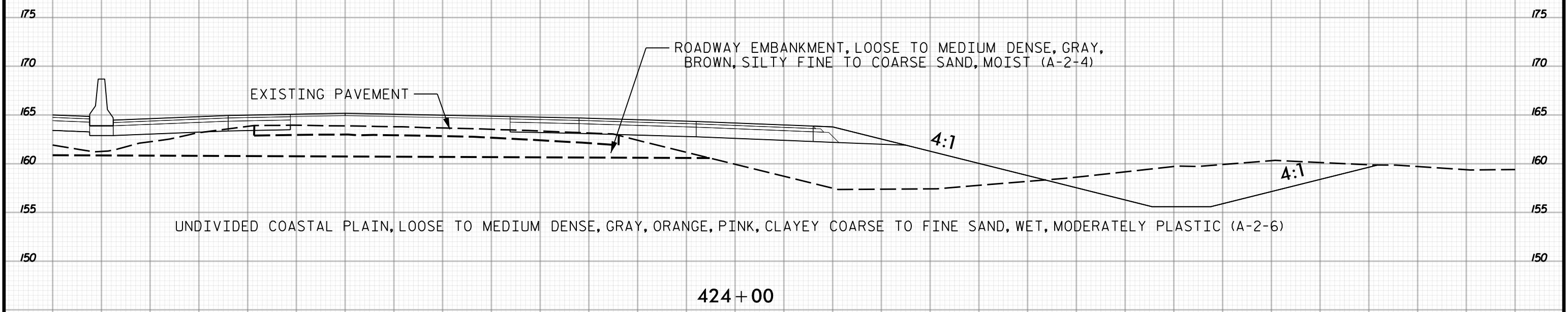

5 0 5 10 15 20 25 30 35 40 45 50 55 60 65 70 75 80 85 90 95 100 105 110 115 120 125 130 135 140 145

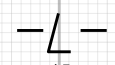



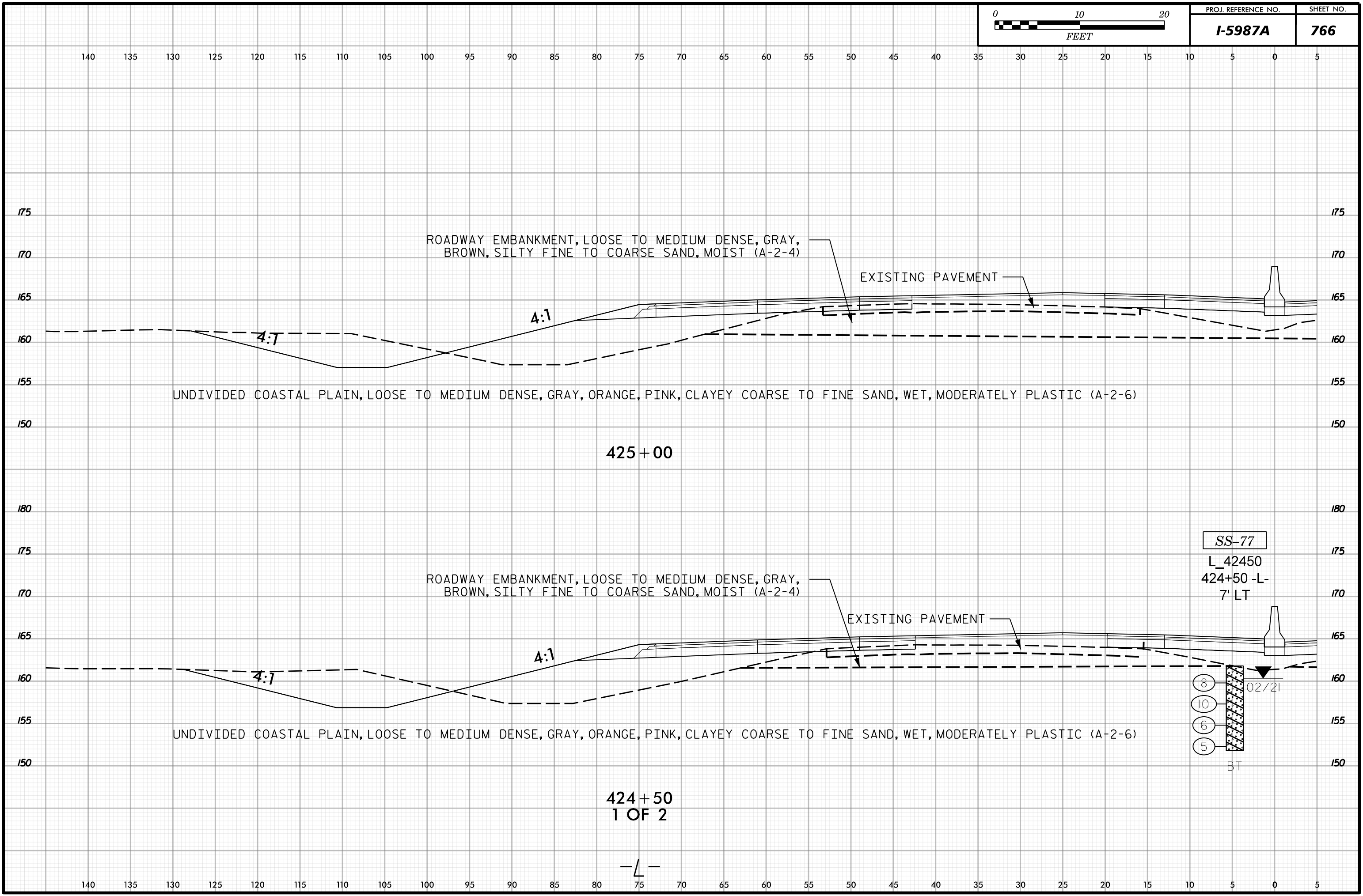

140 135 130 125 120 115 110 105 100 95 90 85 80 75 70 65 60 55 50 45 40 35 30 25 20 15 10 5 0 5

140 135 130 125 120 115 110 105 100 95 90 85 80 75 70 65 60 55 50 45 40 35 30 25 20 15 10 5 0 5

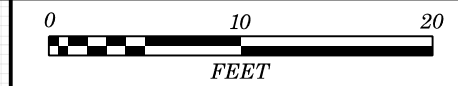

5 0 5 10 15 20 25 30 35 40 45 50 55 60 65 70 75 80 85 90 95 100 105 110 115 120 125 130 135 140 145

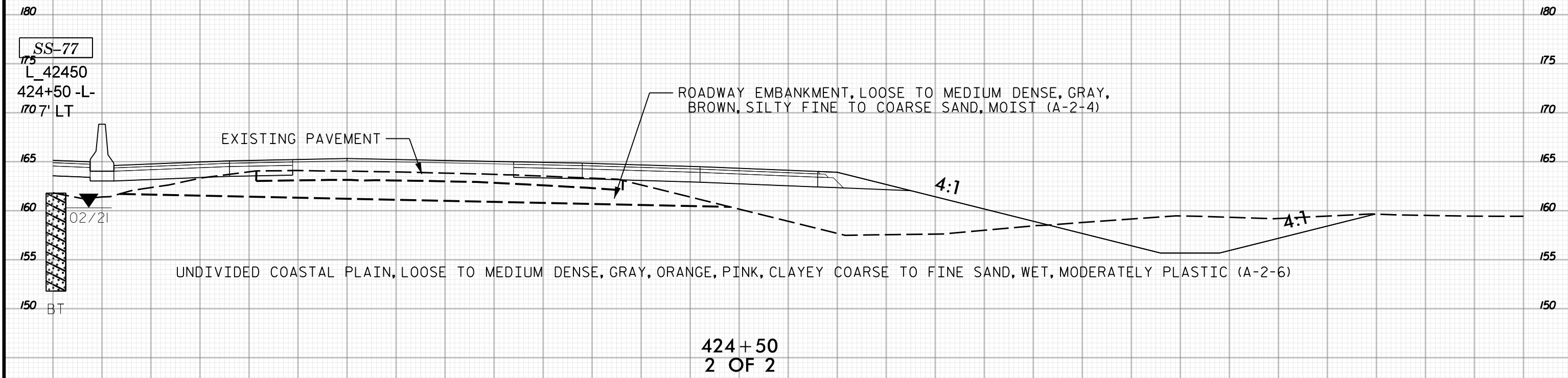
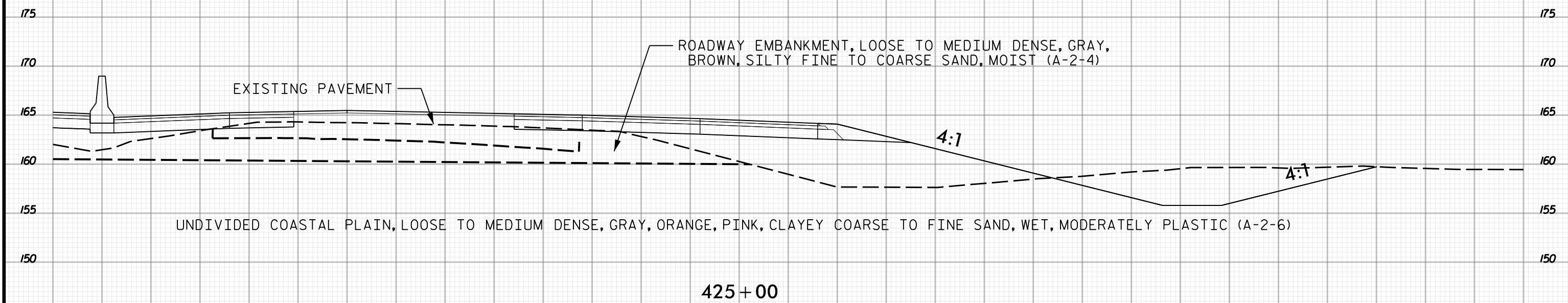

5 0 5 10 15 20 25 30 35 40 45 50 55 60 65 70 75 80 85 90 95 100 105 110 115 120 125 130 135 140 145



140 135 130 125 120 115 110 105 100 95 90 85 80 75 70 65 60 55 50 45 40 35 30 25 20 15 10 5 0 5

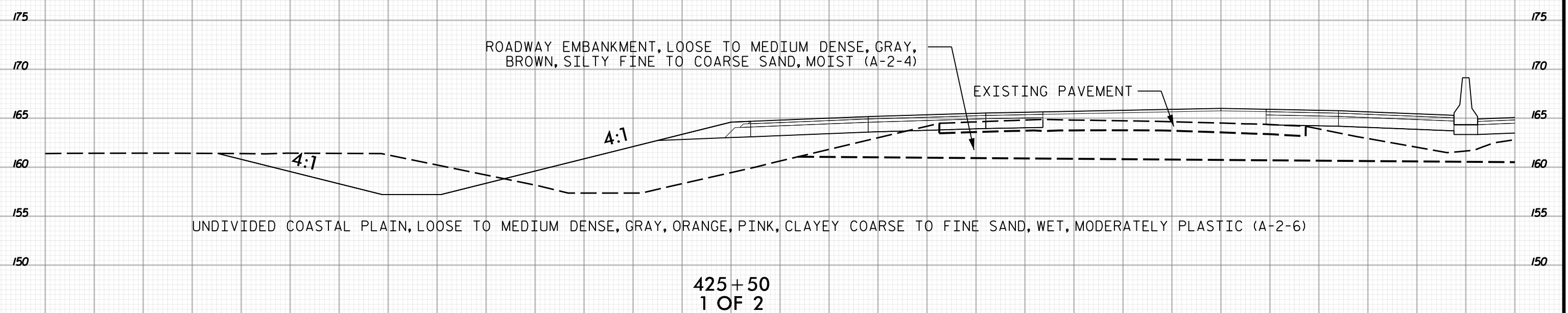
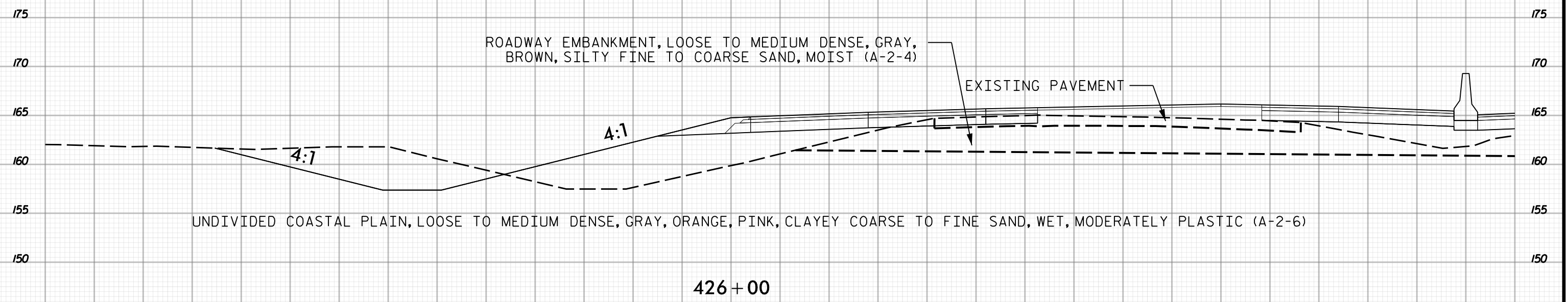

140 135 130 125 120 115 110 105 100 95 90 85 80 75 70 65 60 55 50 45 40 35 30 25 20 15 10 5 0 5

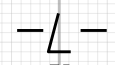



PROJ. REFERENCE NO.	SHEET NO.
I-5987A	769

5 0 5 10 15 20 25 30 35 40 45 50 55 60 65 70 75 80 85 90 95 100 105 110 115 120 125 130 135 140 145

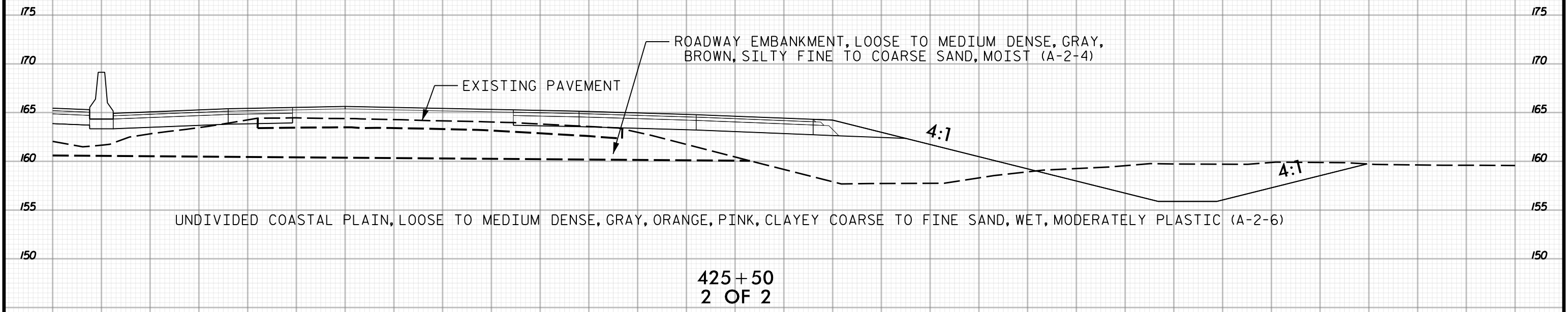
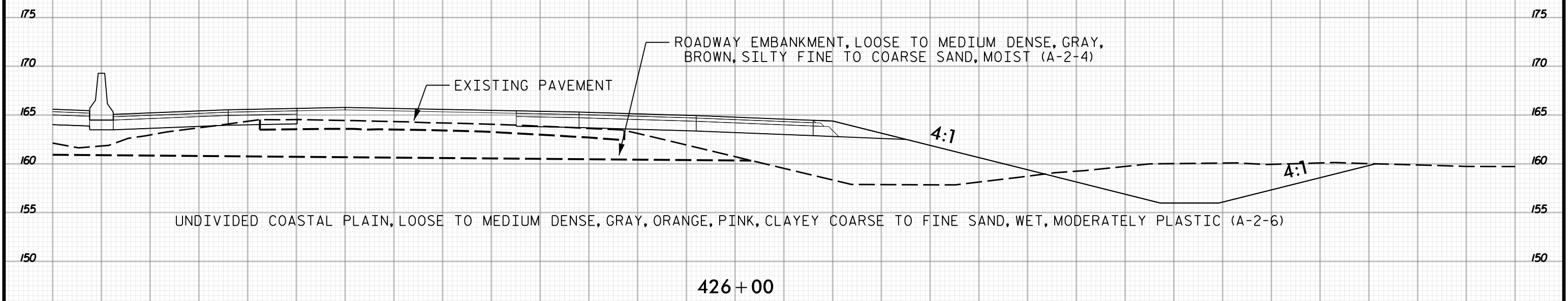

5 0 5 10 15 20 25 30 35 40 45 50 55 60 65 70 75 80 85 90 95 100 105 110 115 120 125 130 135 140 145

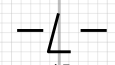

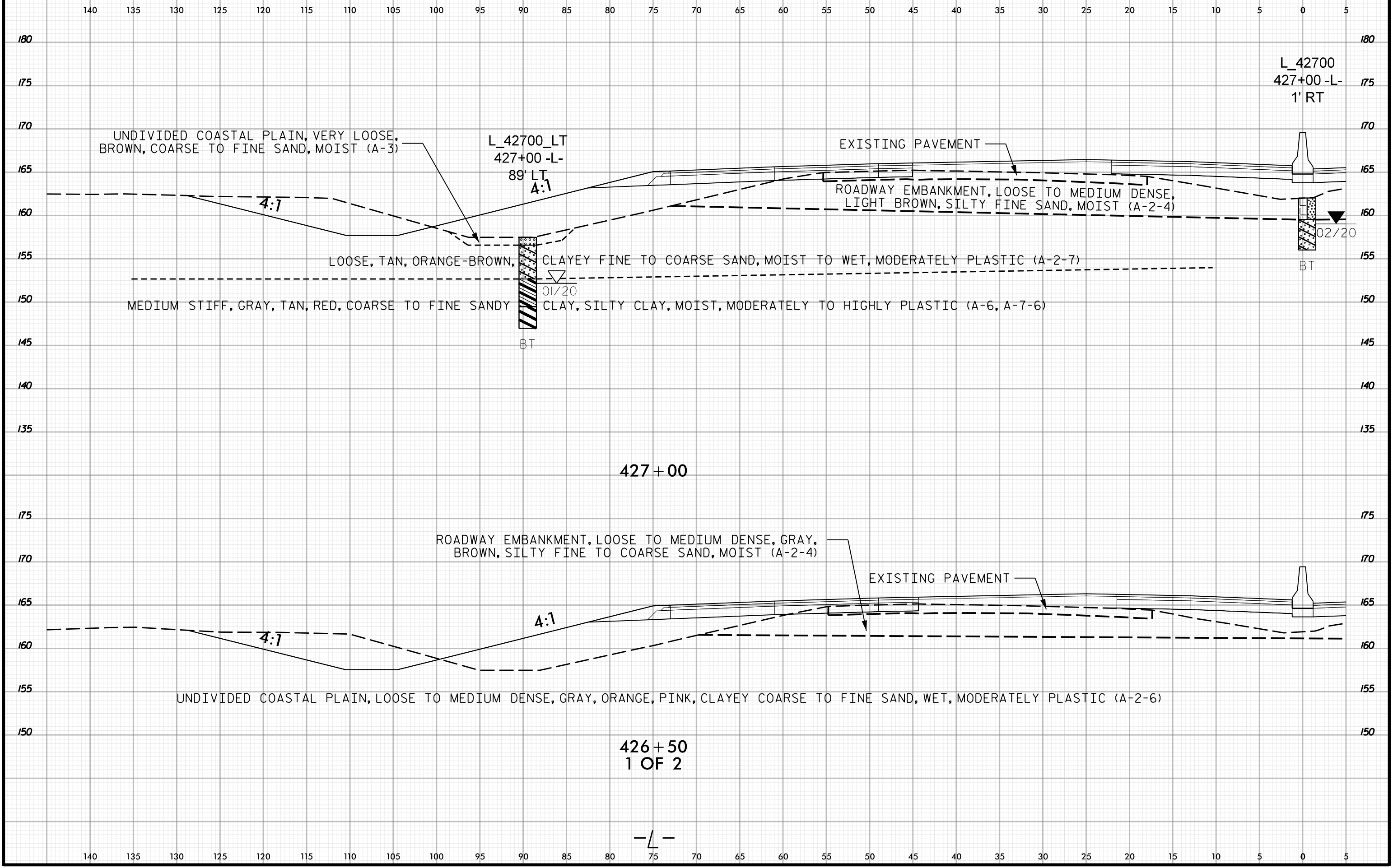

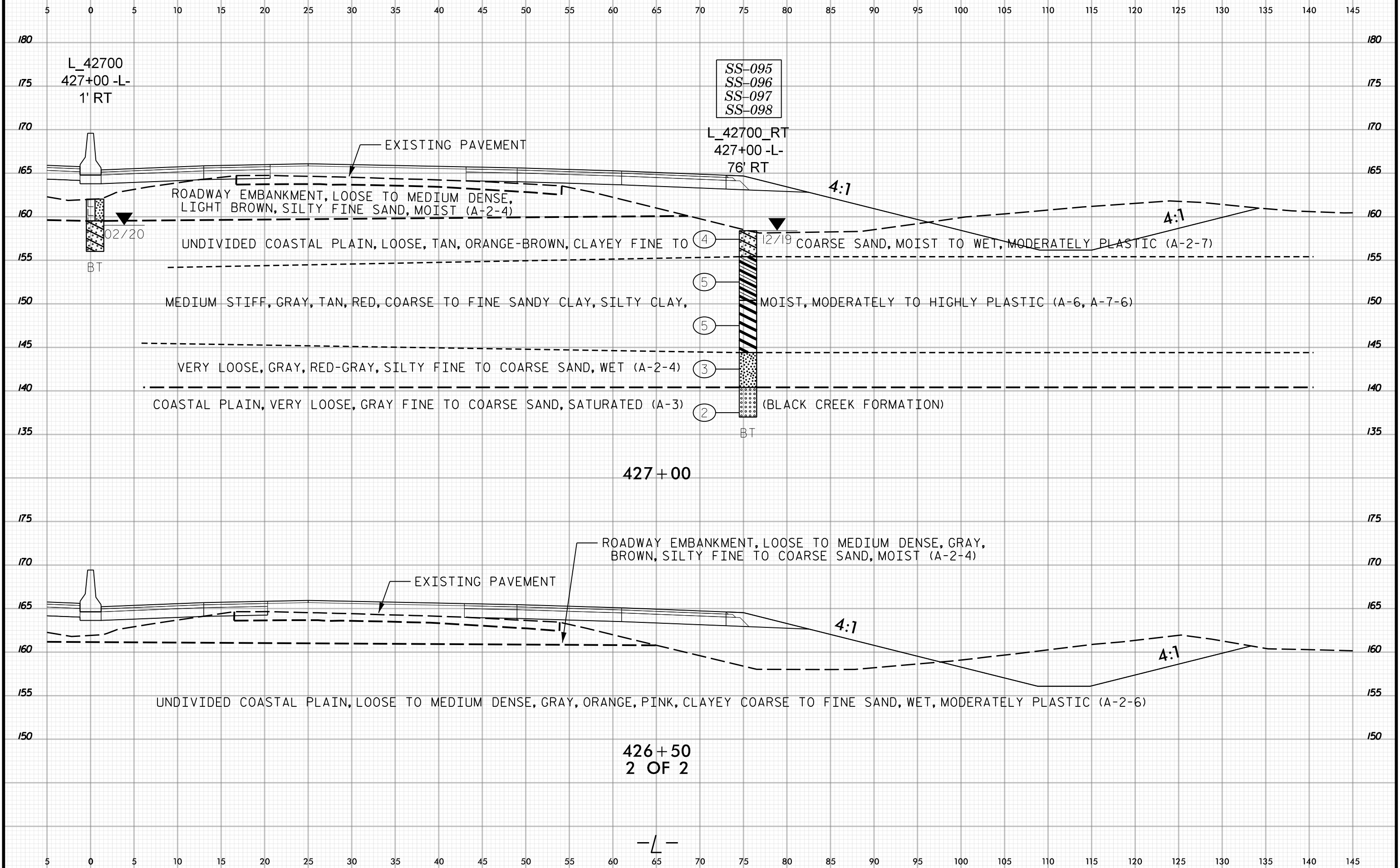

427+00

426+50  
2 OF 2

-L-

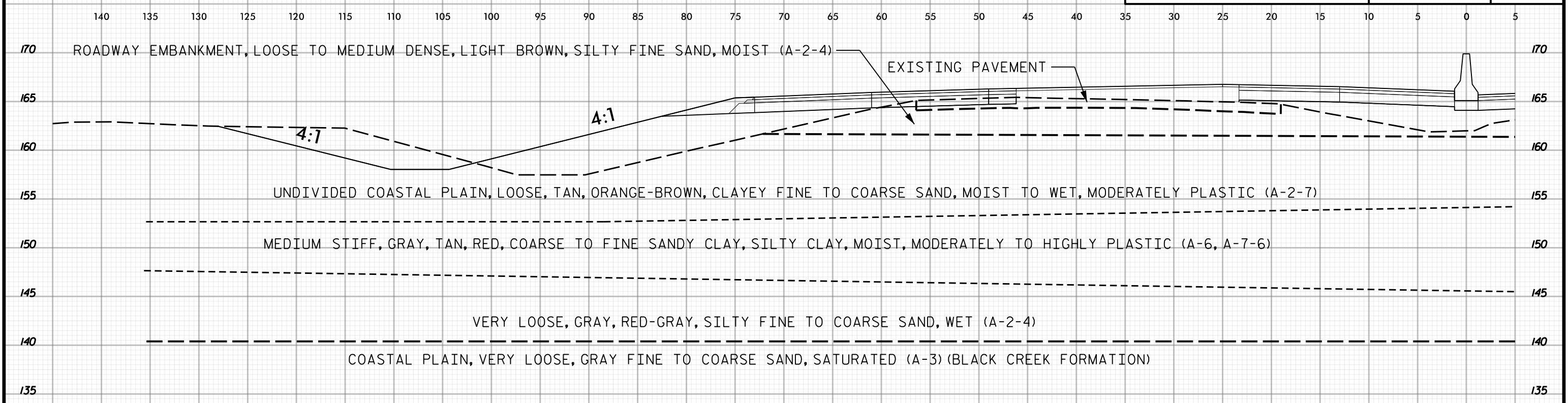

428+00

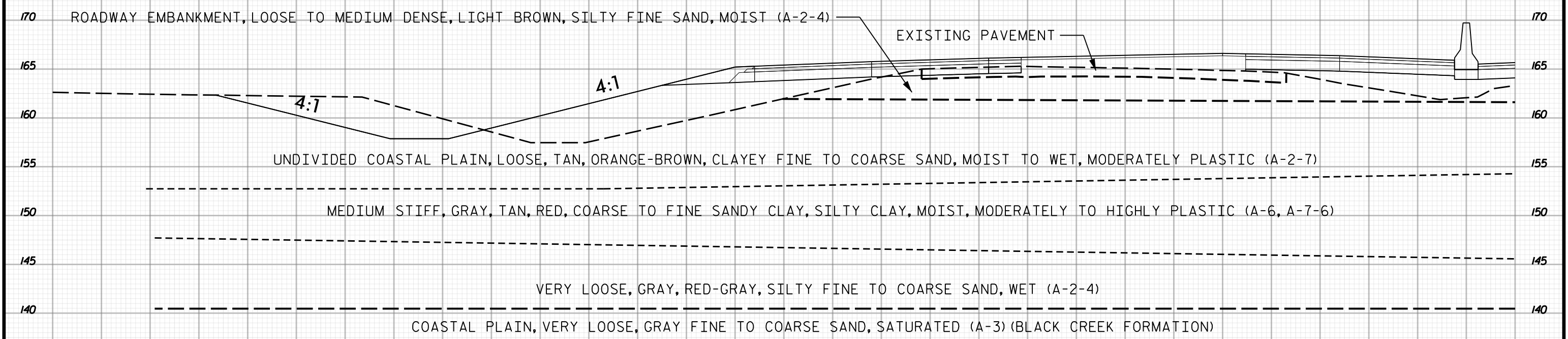

427+50  
1 OF 2

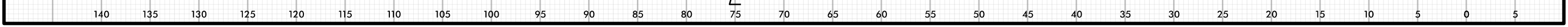
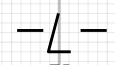

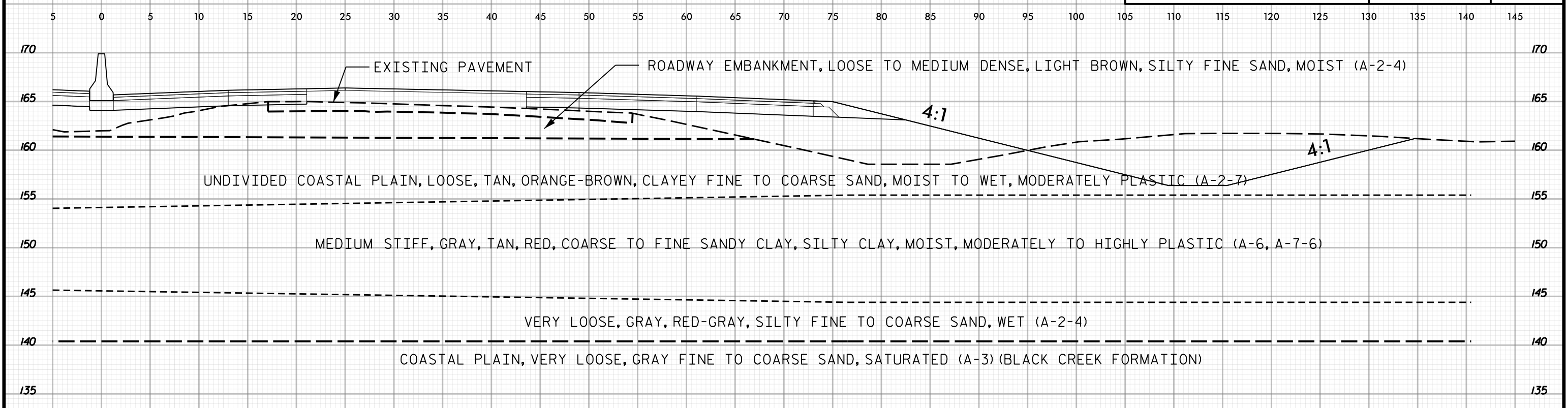

428+00

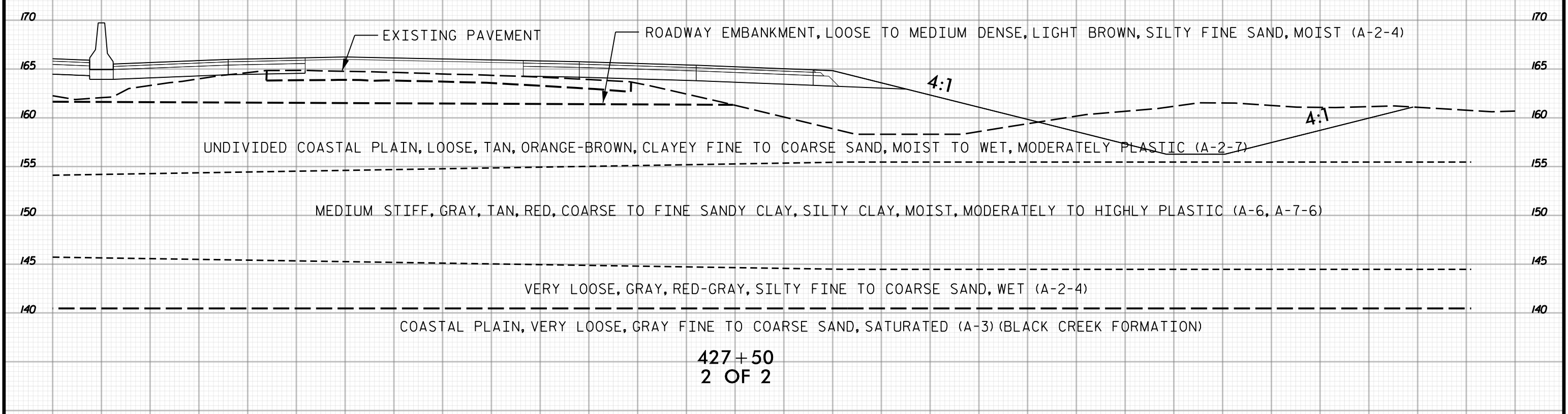

427+50  
2 OF 2

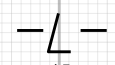





140 135 130 125 120 115 110 105 100 95 90 85 80 75 70 65 60 55 50 45 40 35 30 25 20 15 10 5 0 5

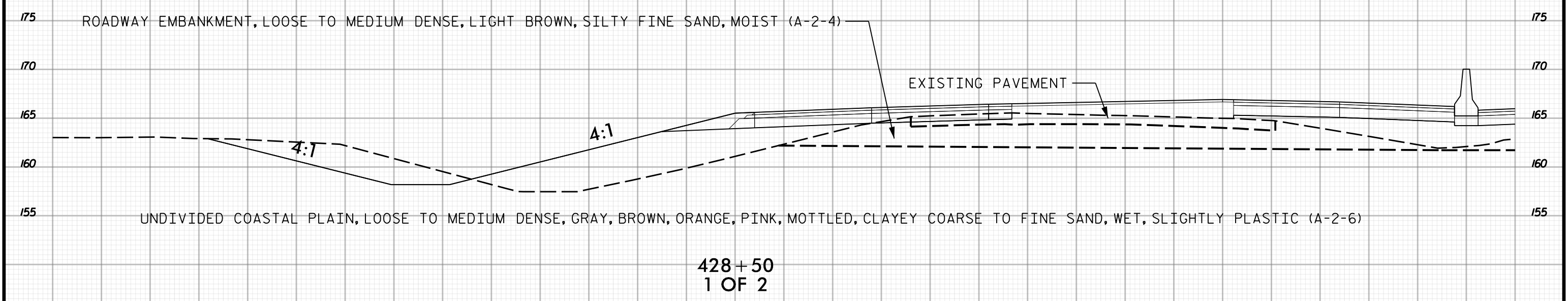
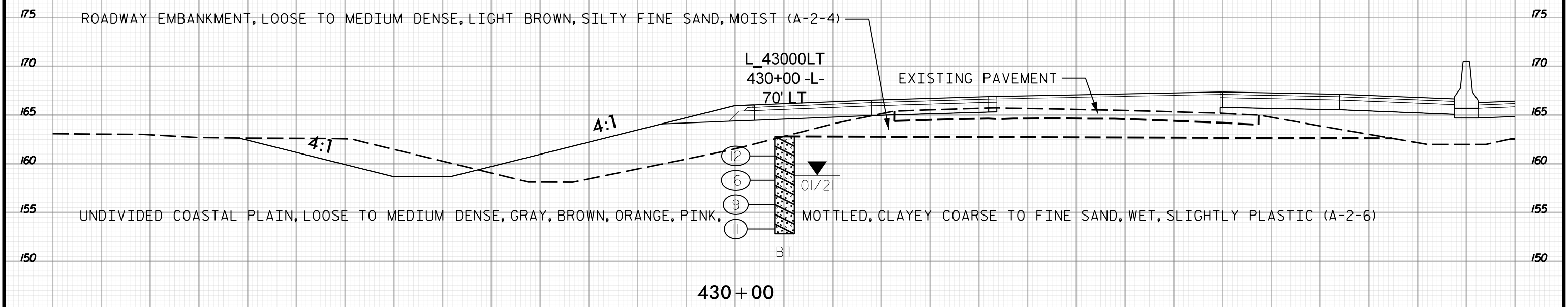

140 135 130 125 120 115 110 105 100 95 90 85 80 75 70 65 60 55 50 45 40 35 30 25 20 15 10 5 0 5



PROJ. REFERENCE NO.	SHEET NO.
I-5987A	775

5 0 5 10 15 20 25 30 35 40 45 50 55 60 65 70 75 80 85 90 95 100 105 110 115 120 125 130 135 140 145

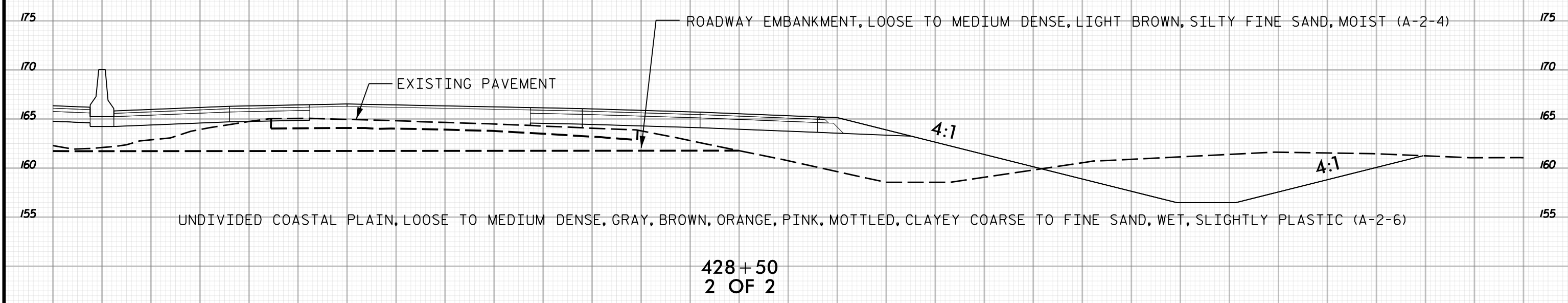
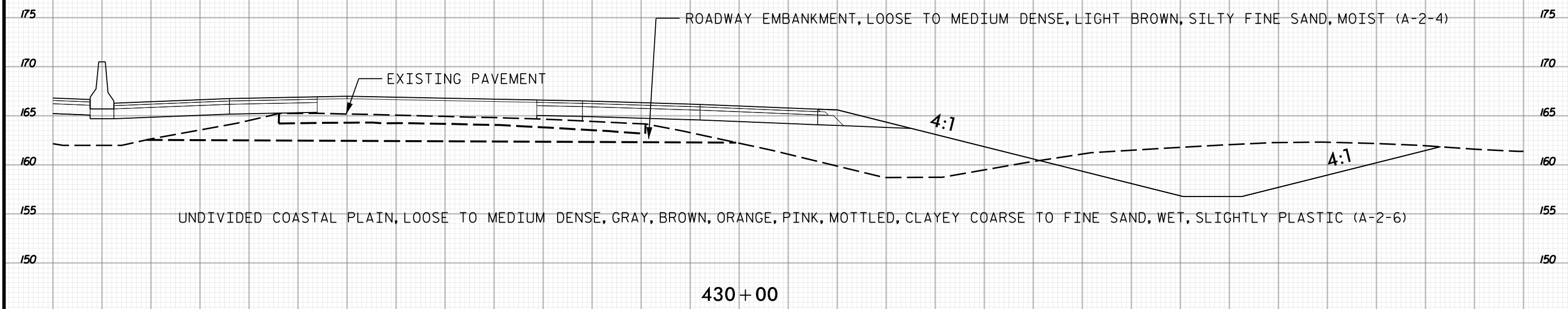

2 OF 2

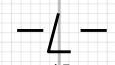

5 0 5 10 15 20 25 30 35 40 45 50 55 60 65 70 75 80 85 90 95 100 105 110 115 120 125 130 135 140 145



PROJ. REFERENCE NO.	SHEET NO.
I-5987A	776

140 135 130 125 120 115 110 105 100 95 90 85 80 75 70 65 60 55 50 45 40 35 30 25 20 15 10 5 0 5

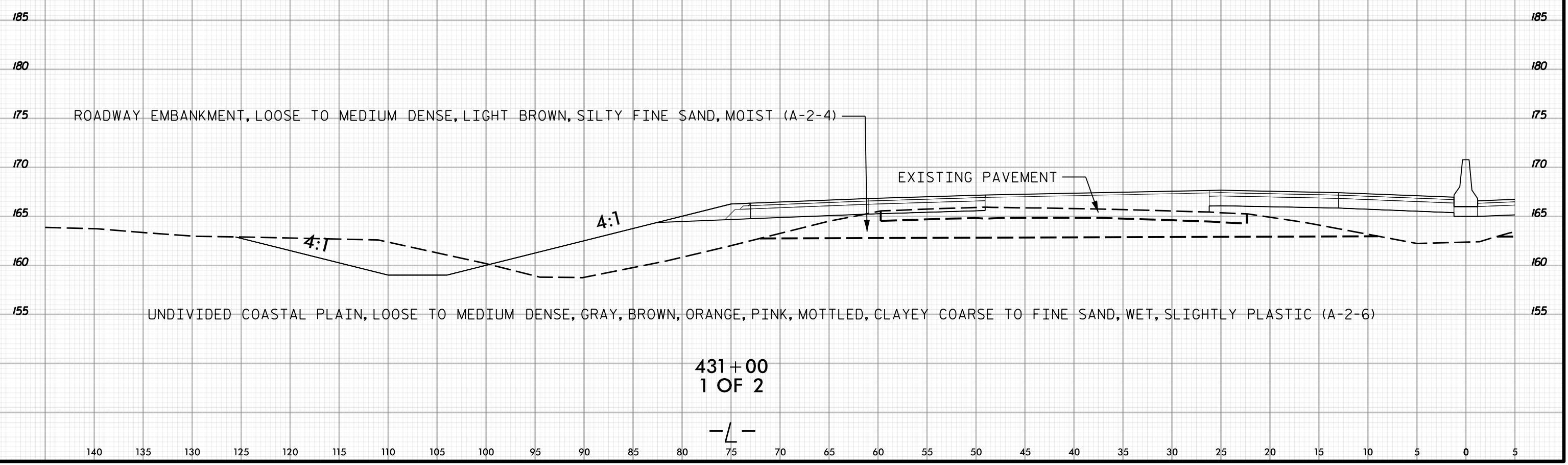

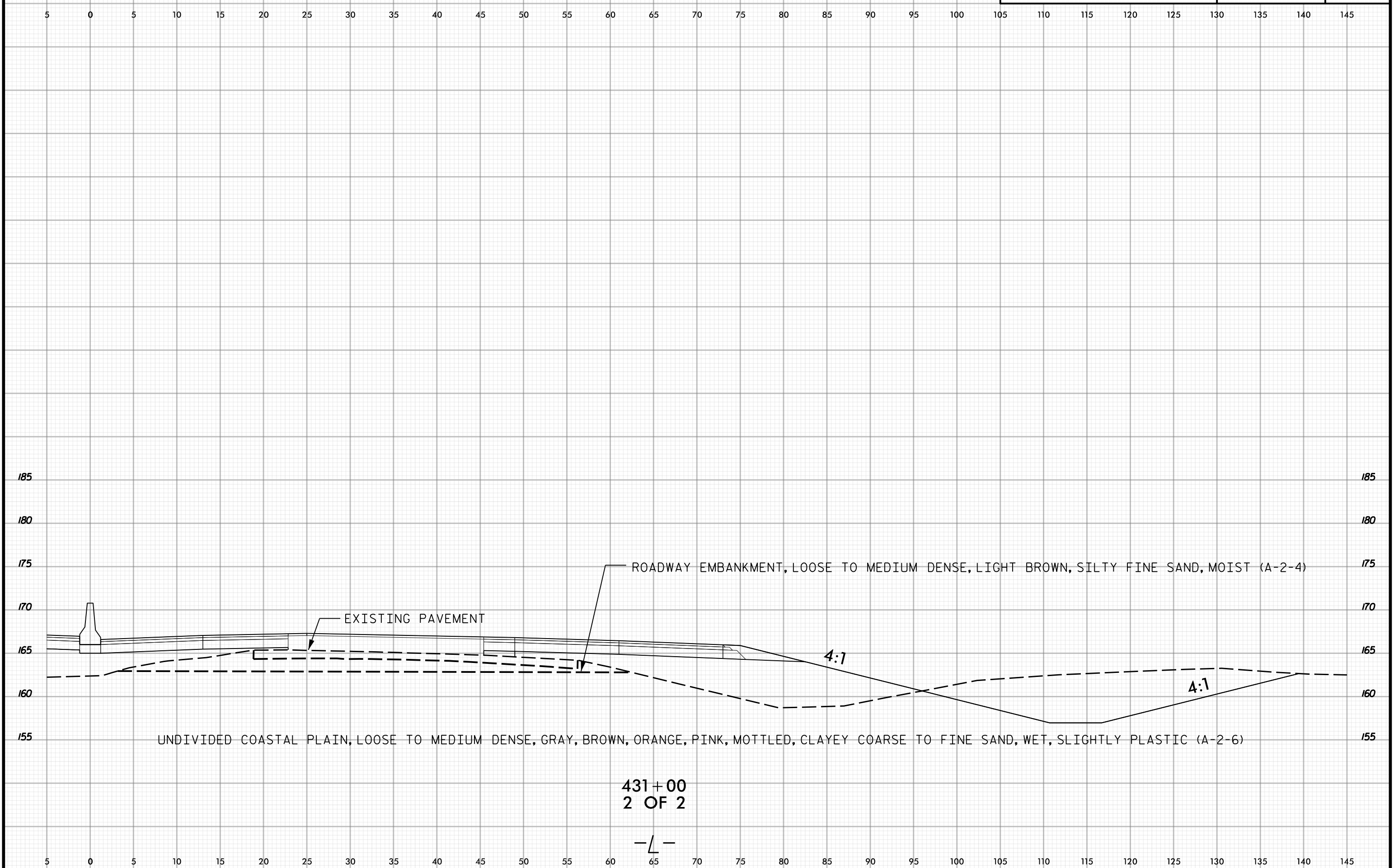

431+00  
2 OF 2

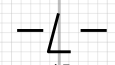

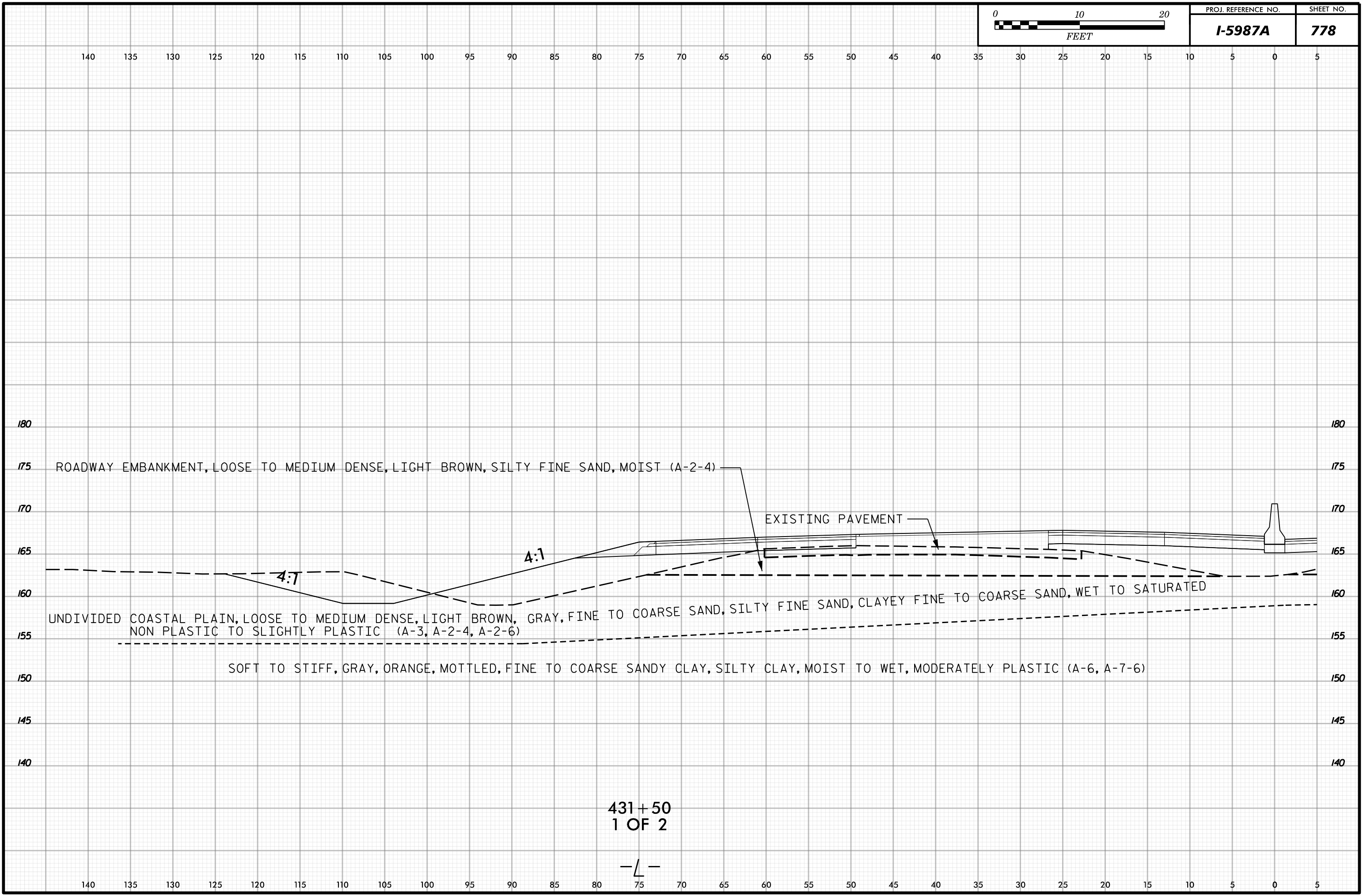

431+50  
1 OF 2

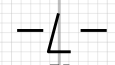



5 0 5 10 15 20 25 30 35 40 45 50 55 60 65 70 75 80 85 90 95 100 105 110 115 120 125 130 135 140 145

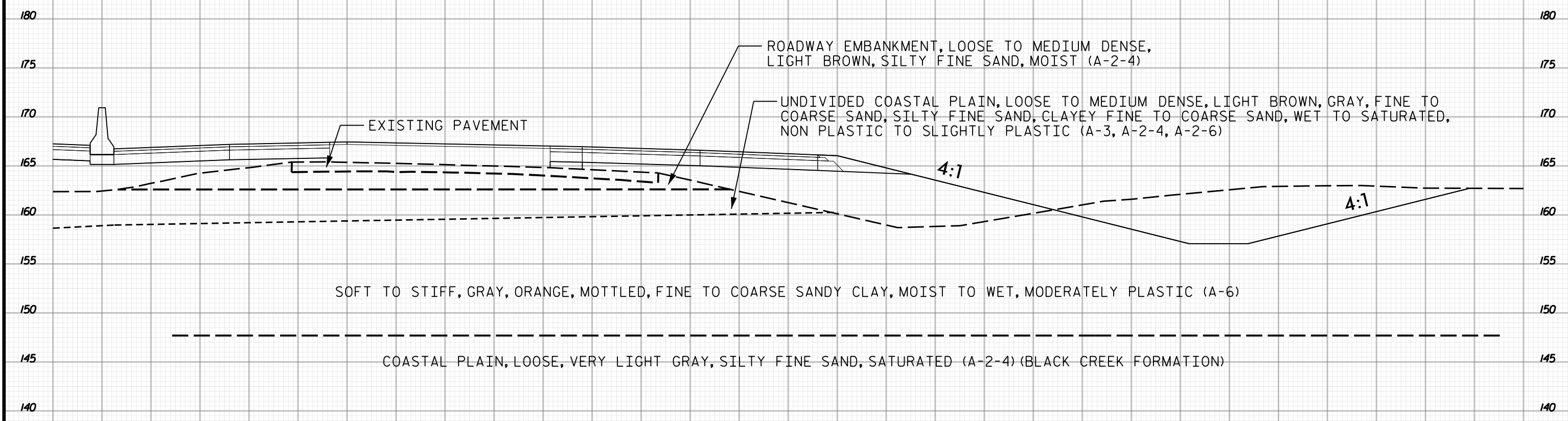

431+50  
2 OF 2

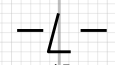

5 0 5 10 15 20 25 30 35 40 45 50 55 60 65 70 75 80 85 90 95 100 105 110 115 120 125 130 135 140 145



140 135 130 125 120 115 110 105 100 95 90 85 80 75 70 65 60 55 50 45 40 35 30 25 20 15 10 5 0 5

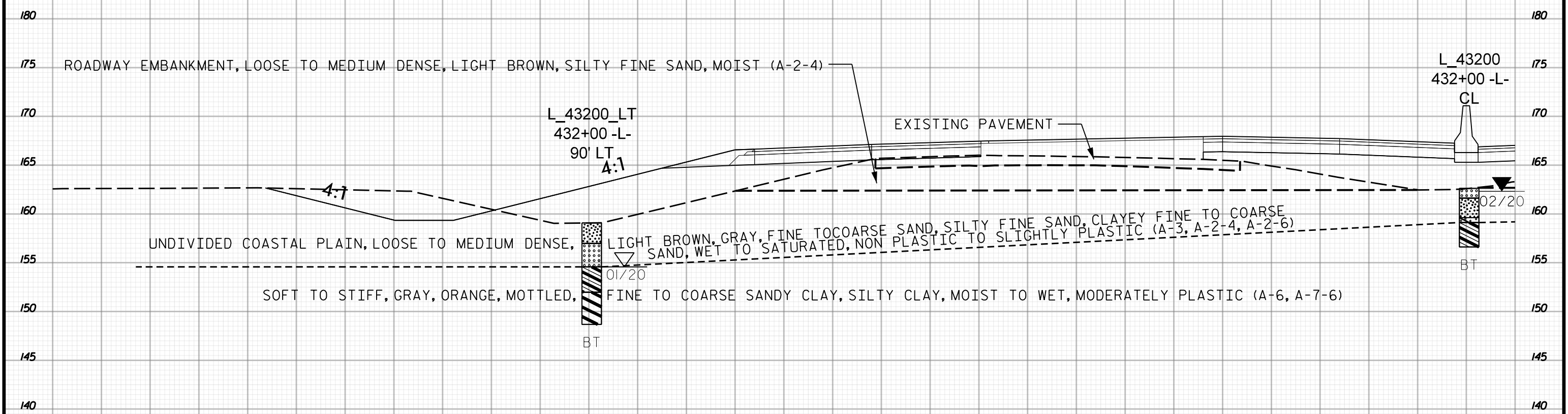

432 + 00  
1 OF 2

-L-

140 135 130 125 120 115 110 105 100 95 90 85 80 75 70 65 60 55 50 45 40 35 30 25 20 15 10 5 0 5



5 0 5 10 15 20 25 30 35 40 45 50 55 60 65 70 75 80 85 90 95 100 105 110 115 120 125 130 135 140 145

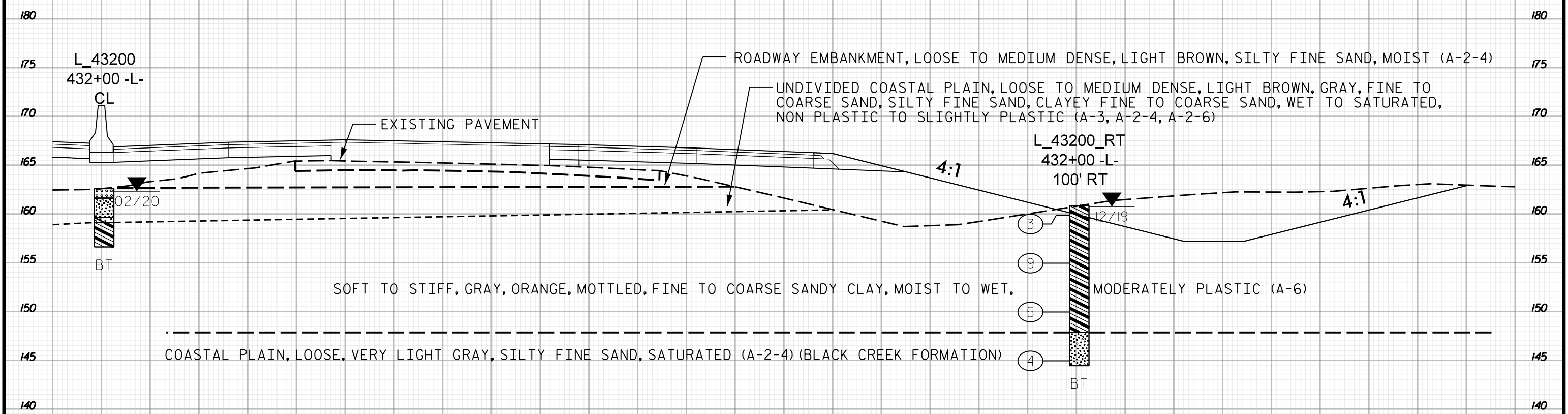

432+00  
2 OF 2

-L-

5 0 5 10 15 20 25 30 35 40 45 50 55 60 65 70 75 80 85 90 95 100 105 110 115 120 125 130 135 140 145



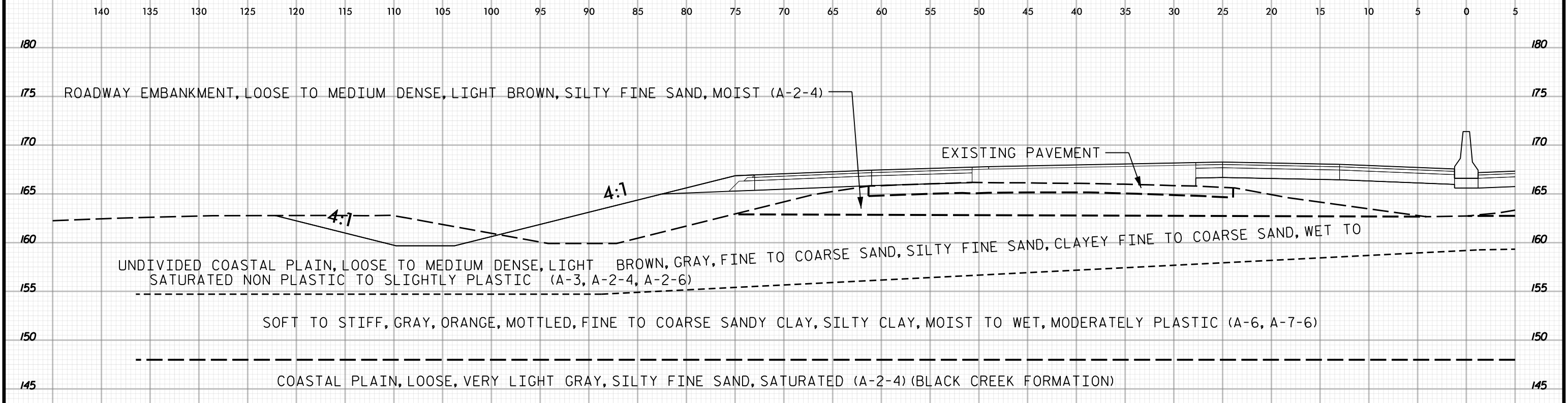

433+00

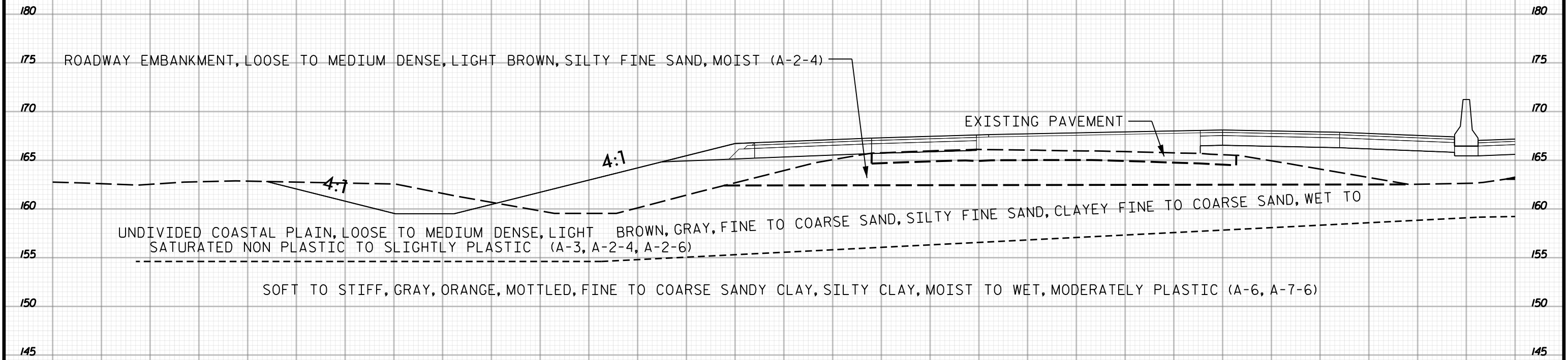

432+50  
1 OF 2

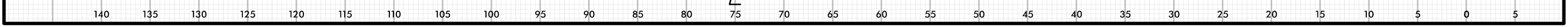
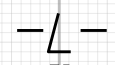

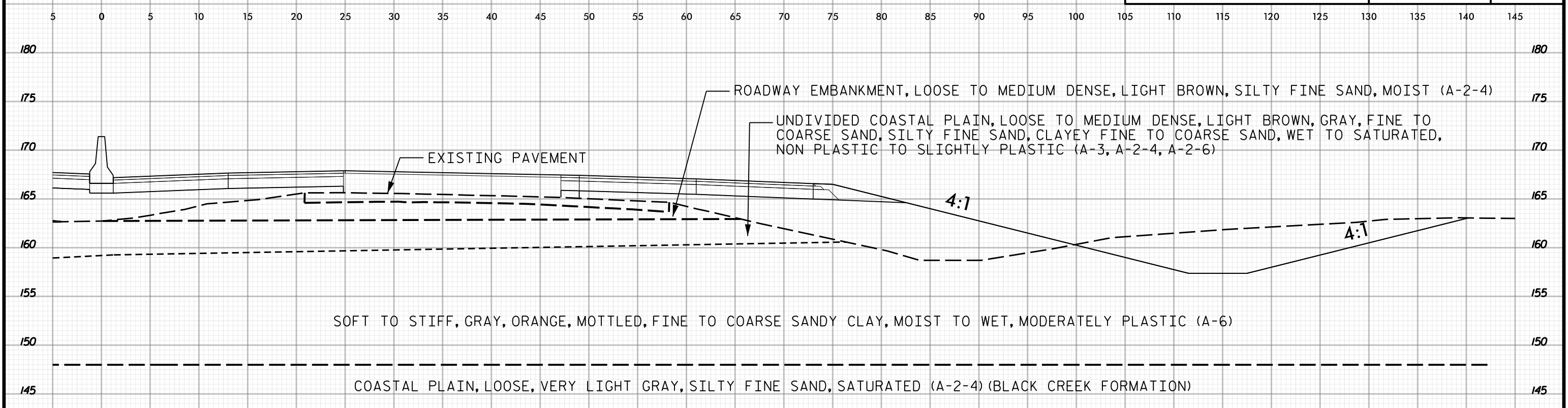

433+00

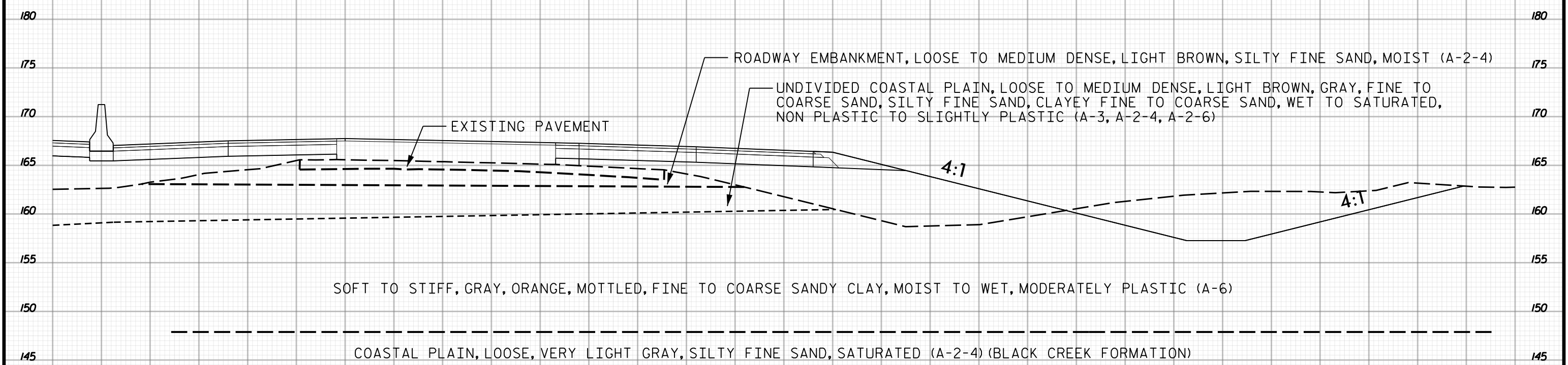

432+50  
2 OF 2

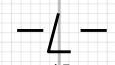



140 135 130 125 120 115 110 105 100 95 90 85 80 75 70 65 60 55 50 45 40 35 30 25 20 15 10 5 0 5

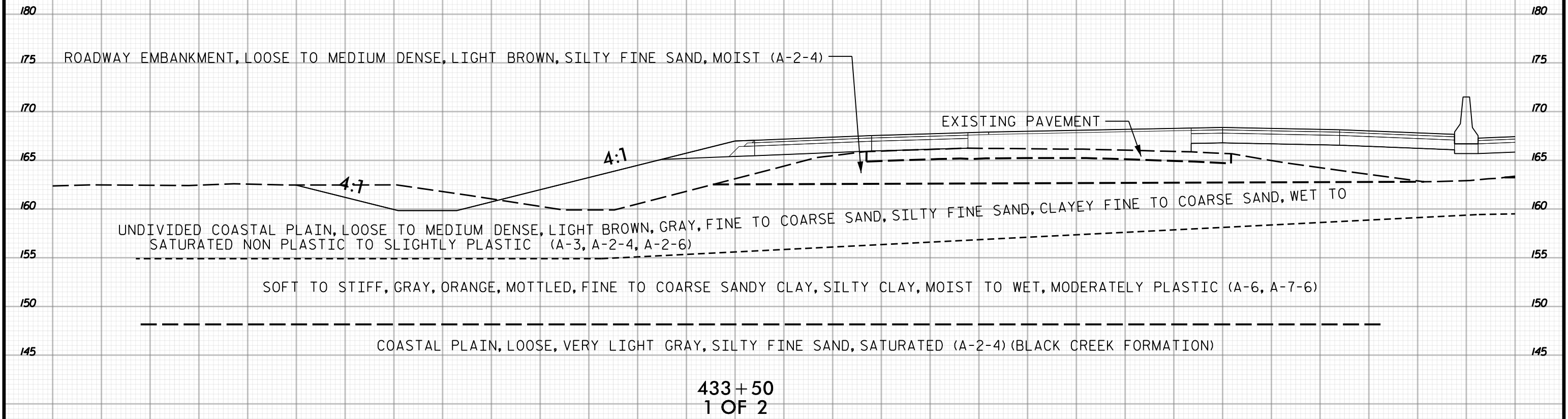
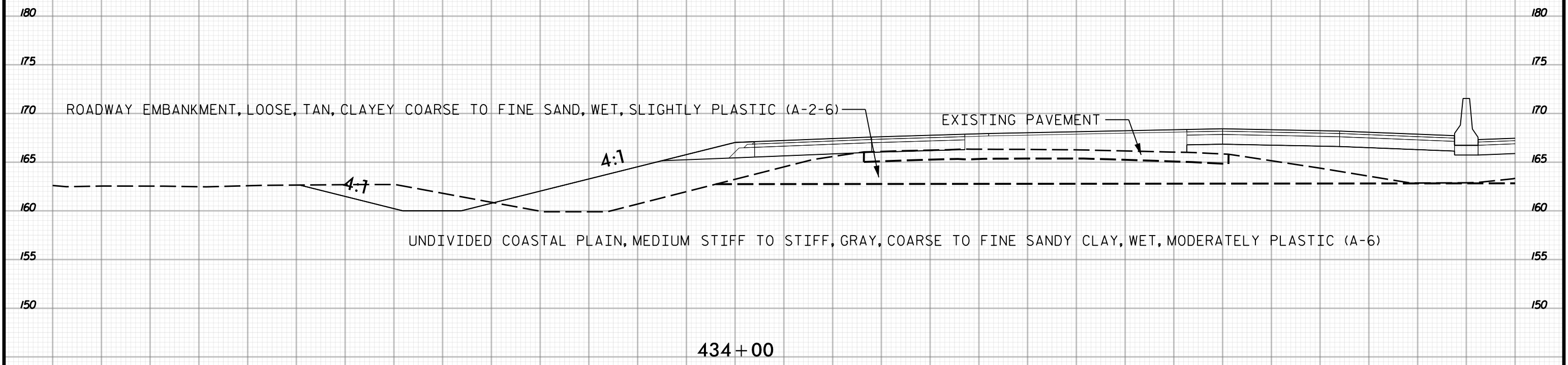

140 135 130 125 120 115 110 105 100 95 90 85 80 75 70 65 60 55 50 45 40 35 30 25 20 15 10 5 0 5

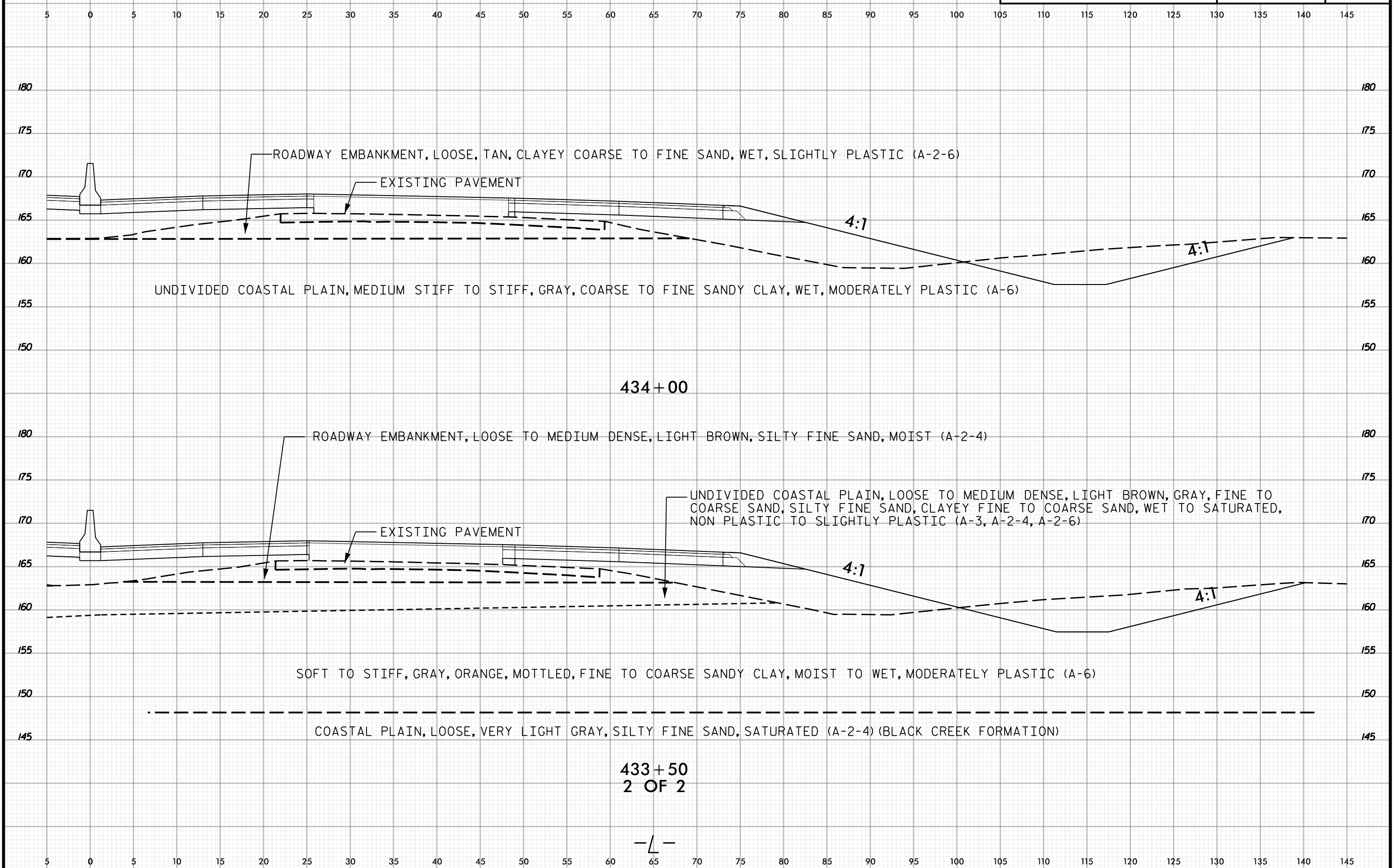

433+50  
2 OF 2

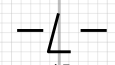



140 135 130 125 120 115 110 105 100 95 90 85 80 75 70 65 60 55 50 45 40 35 30 25 20 15 10 5 0 5

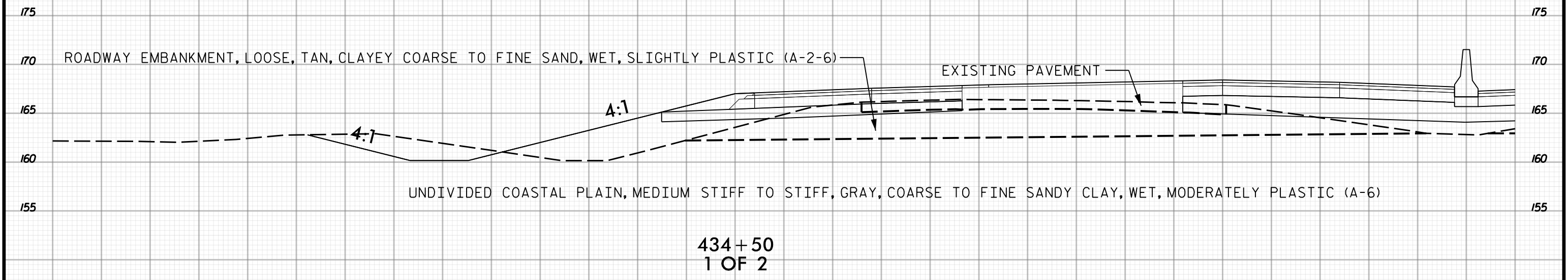
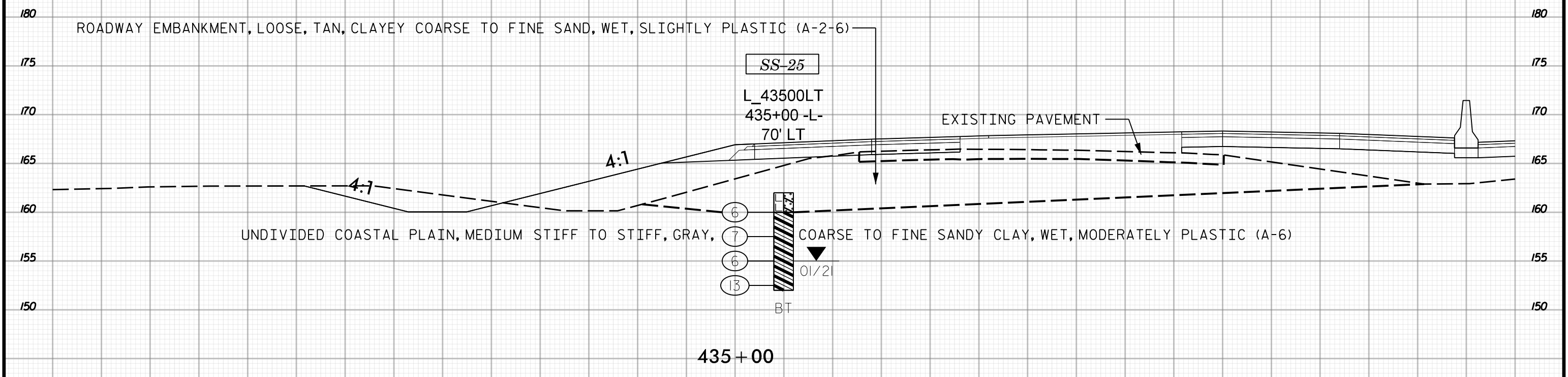

140 135 130 125 120 115 110 105 100 95 90 85 80 75 70 65 60 55 50 45 40 35 30 25 20 15 10 5 0 5



5 0 5 10 15 20 25 30 35 40 45 50 55 60 65 70 75 80 85 90 95 100 105 110 115 120 125 130 135 140 145

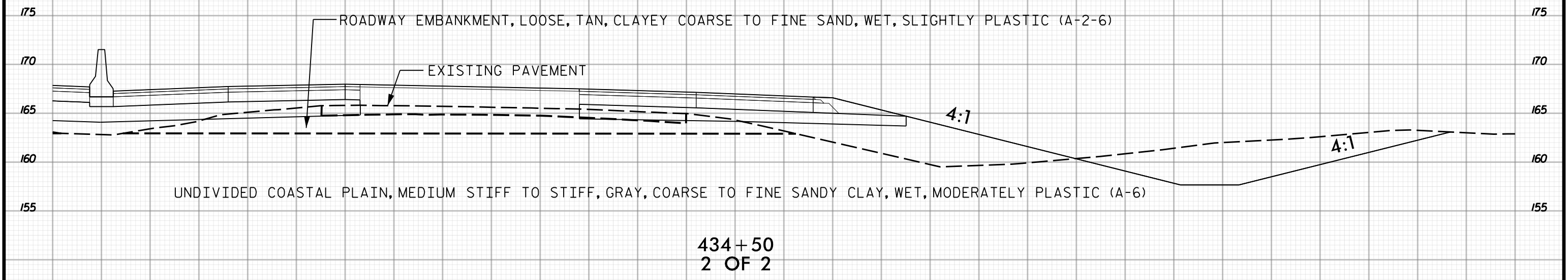
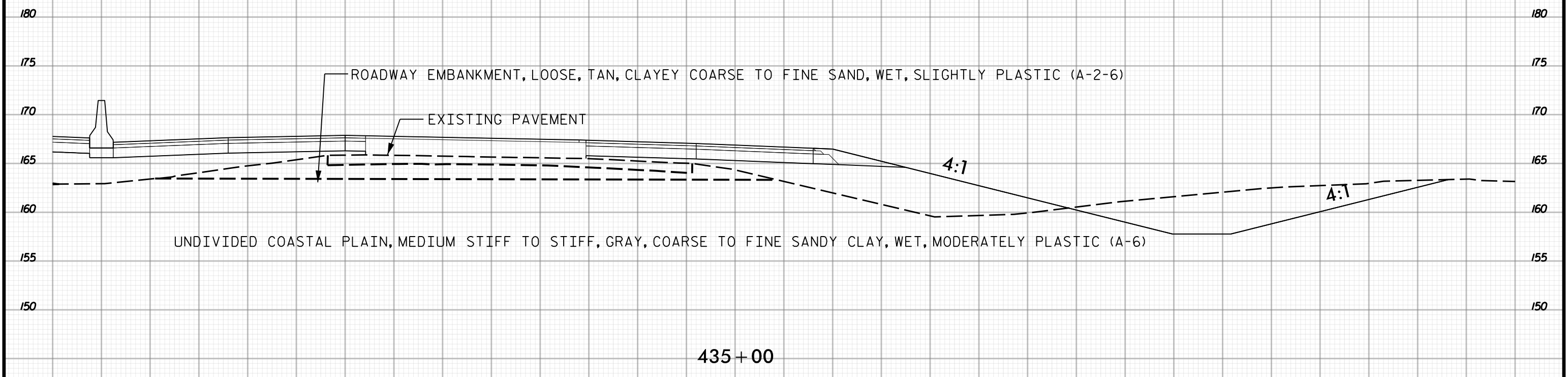

5 0 5 10 15 20 25 30 35 40 45 50 55 60 65 70 75 80 85 90 95 100 105 110 115 120 125 130 135 140 145



PROJ. REFERENCE NO.	SHEET NO.
I-5987A	788

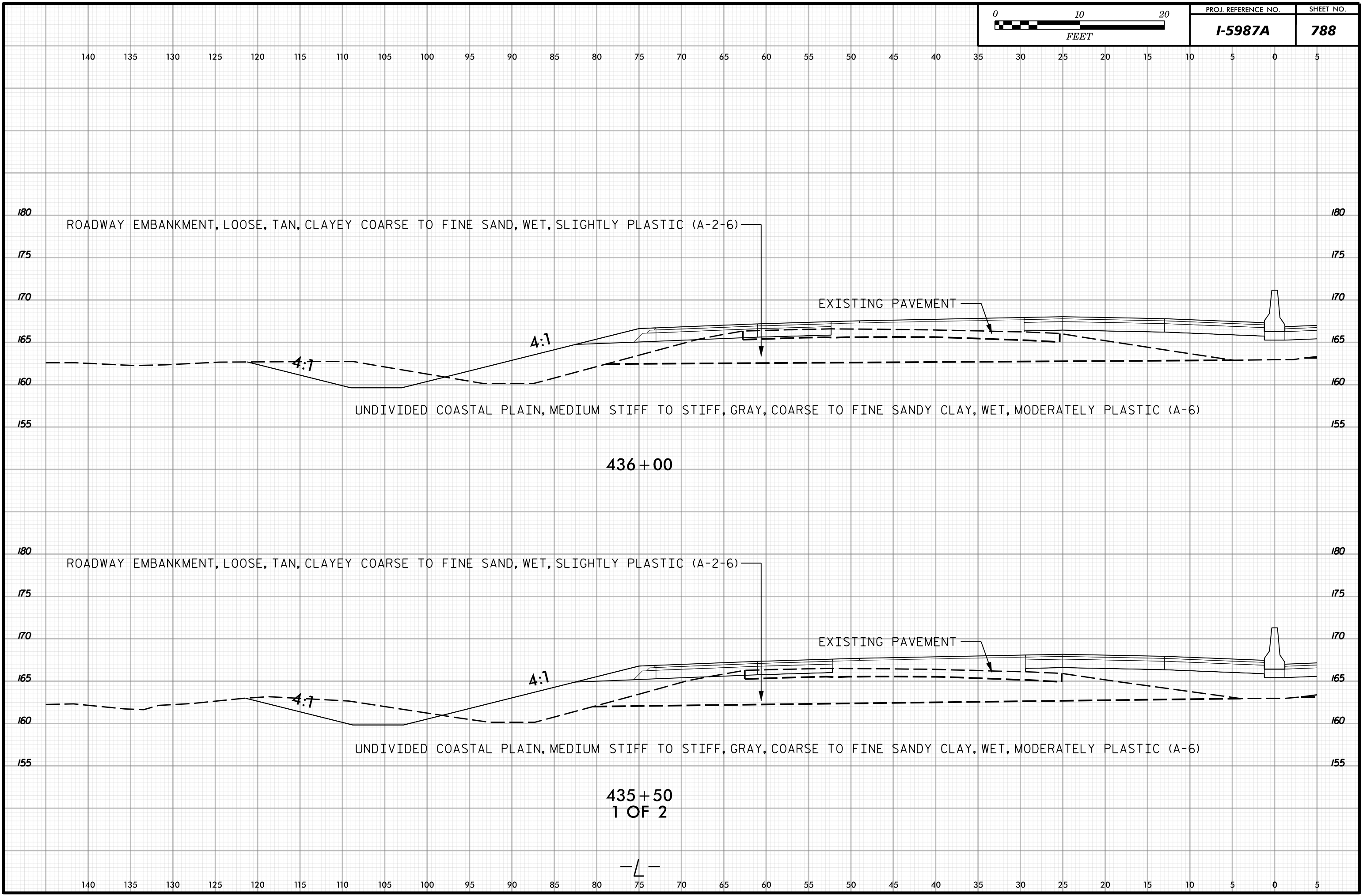

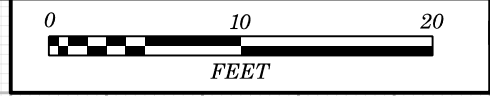

PROJ. REFERENCE NO.	SHEET NO.
I-5987A	789

5 0 5 10 15 20 25 30 35 40 45 50 55 60 65 70 75 80 85 90 95 100 105 110 115 120 125 130 135 140 145

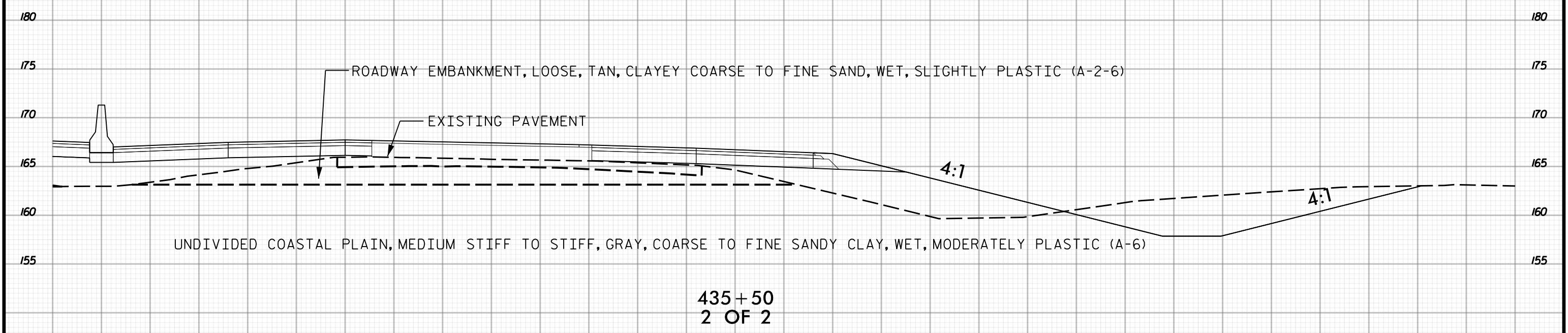
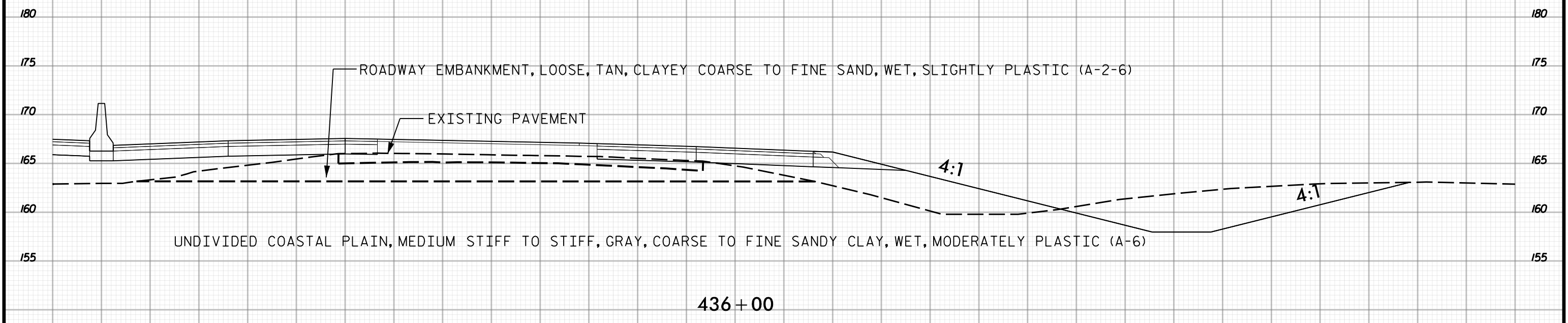

5 0 5 10 15 20 25 30 35 40 45 50 55 60 65 70 75 80 85 90 95 100 105 110 115 120 125 130 135 140 145

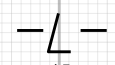





140 135 130 125 120 115 110 105 100 95 90 85 80 75 70 65 60 55 50 45 40 35 30 25 20 15 10 5 0 5

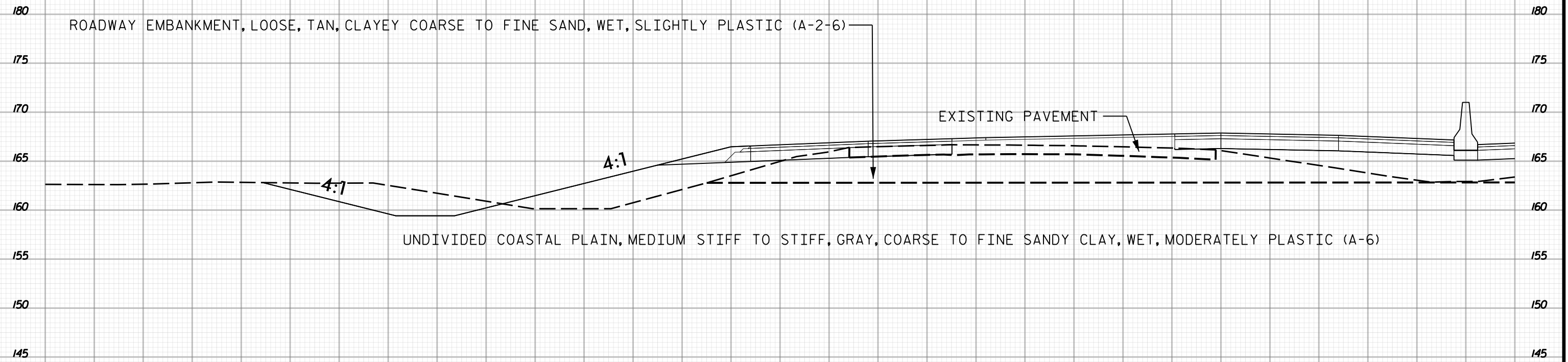

436+50  
1 OF 2

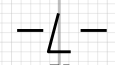

140 135 130 125 120 115 110 105 100 95 90 85 80 75 70 65 60 55 50 45 40 35 30 25 20 15 10 5 0 5

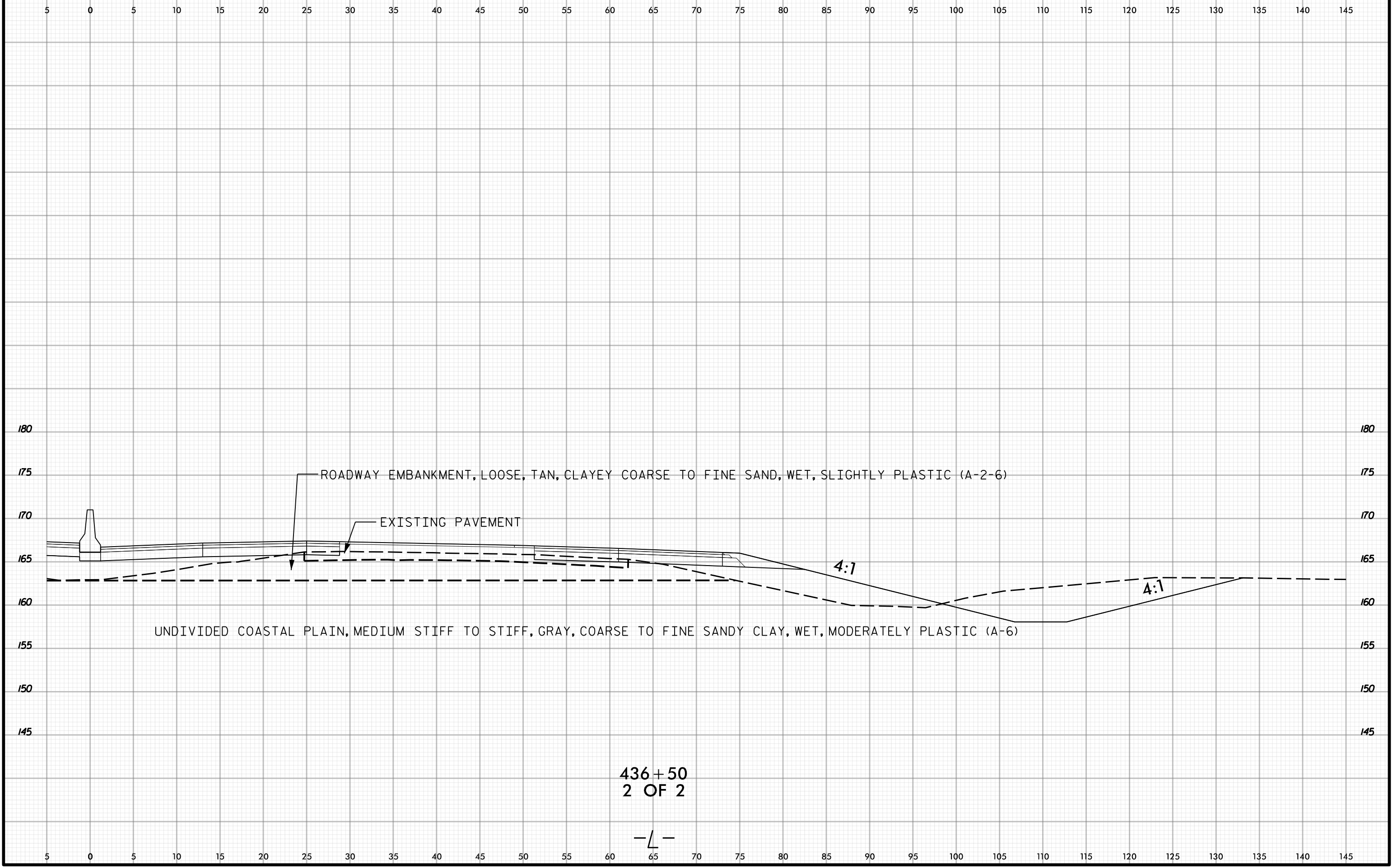

436+50  
2 OF 2

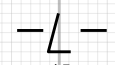



140 135 130 125 120 115 110 105 100 95 90 85 80 75 70 65 60 55 50 45 40 35 30 25 20 15 10 5 0 5

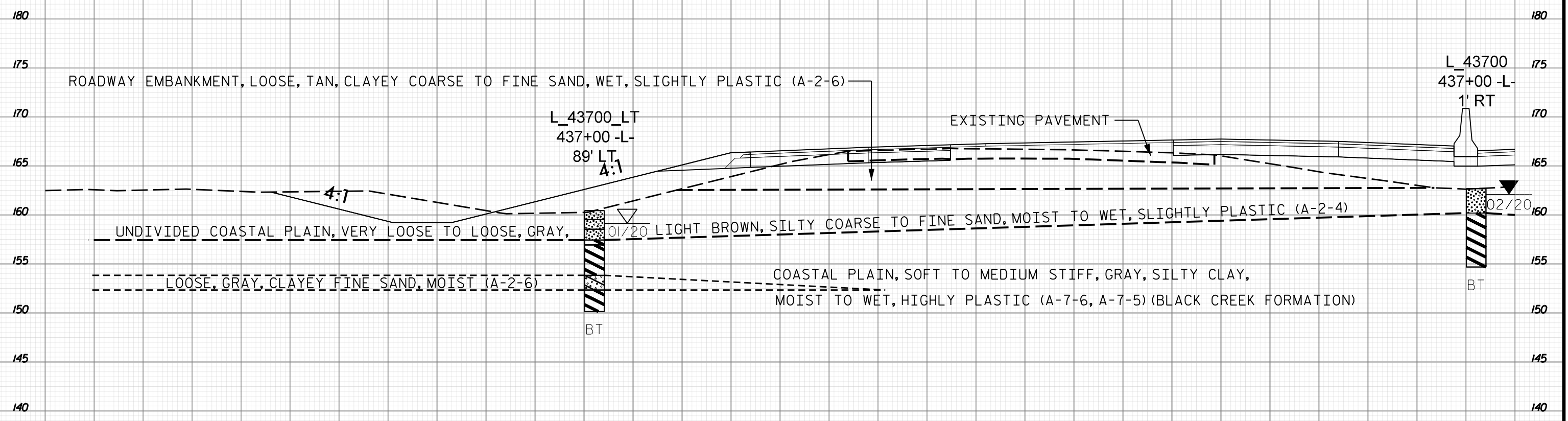

437+00  
1 OF 2

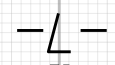

140 135 130 125 120 115 110 105 100 95 90 85 80 75 70 65 60 55 50 45 40 35 30 25 20 15 10 5 0 5

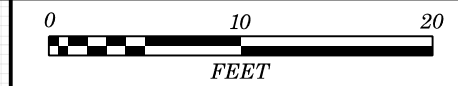

5 0 5 10 15 20 25 30 35 40 45 50 55 60 65 70 75 80 85 90 95 100 105 110 115 120 125 130 135 140 145

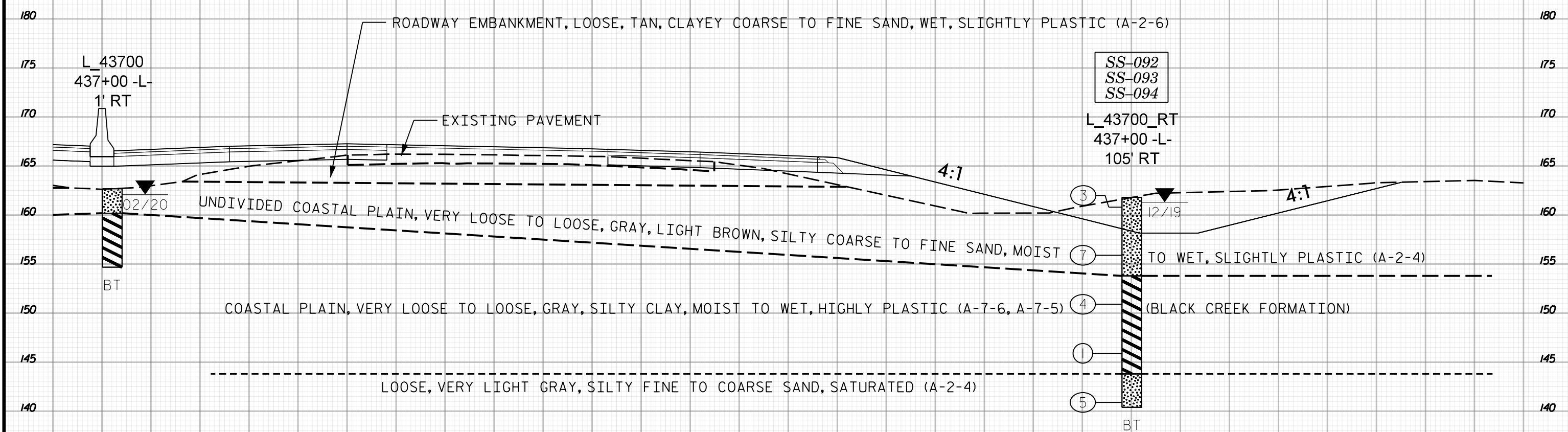

437+00  
2 OF 2

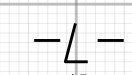

5 0 5 10 15 20 25 30 35 40 45 50 55 60 65 70 75 80 85 90 95 100 105 110 115 120 125 130 135 140 145

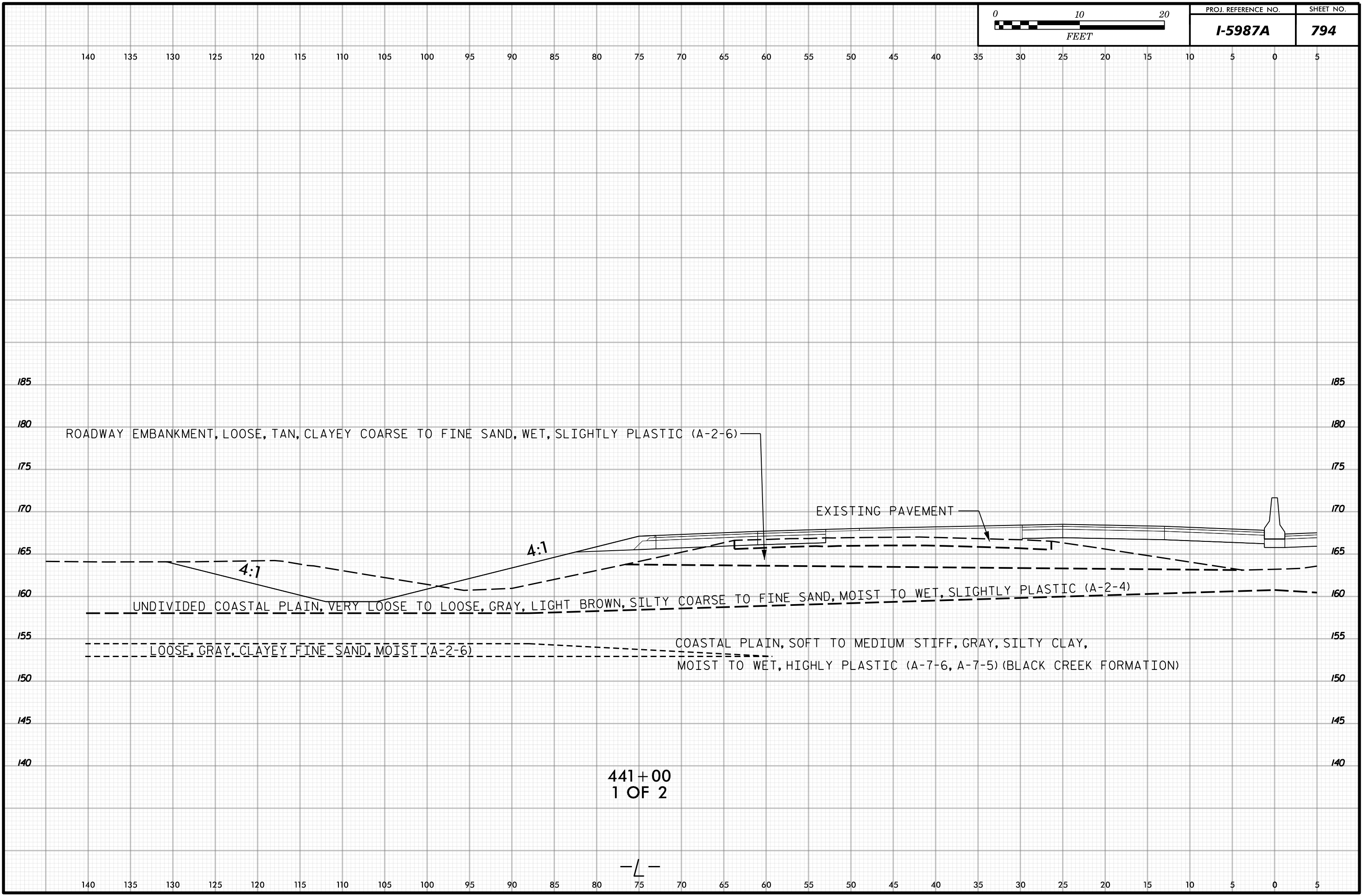

ROADWAY EMBANKMENT, LOOSE, TAN, CLAYEY COARSE TO FINE SAND, WET, SLIGHTLY PLASTIC (A-2-6)

EXISTING PAVEMENT

4:1

4:1

UNDIVIDED COASTAL PLAIN, VERY LOOSE TO LOOSE, GRAY, LIGHT BROWN, SILTY COARSE TO FINE SAND, MOIST TO WET, SLIGHTLY PLASTIC (A-2-4)

LOOSE, GRAY, CLAYEY FINE SAND, MOIST (A-2-6)

COASTAL PLAIN, SOFT TO MEDIUM STIFF, GRAY, SILTY CLAY, MOIST TO WET, HIGHLY PLASTIC (A-7-6, A-7-5) (BLACK CREEK FORMATION)

441+00  
1 OF 2

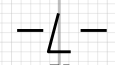



5 0 5 10 15 20 25 30 35 40 45 50 55 60 65 70 75 80 85 90 95 100 105 110 115 120 125 130 135 140 145

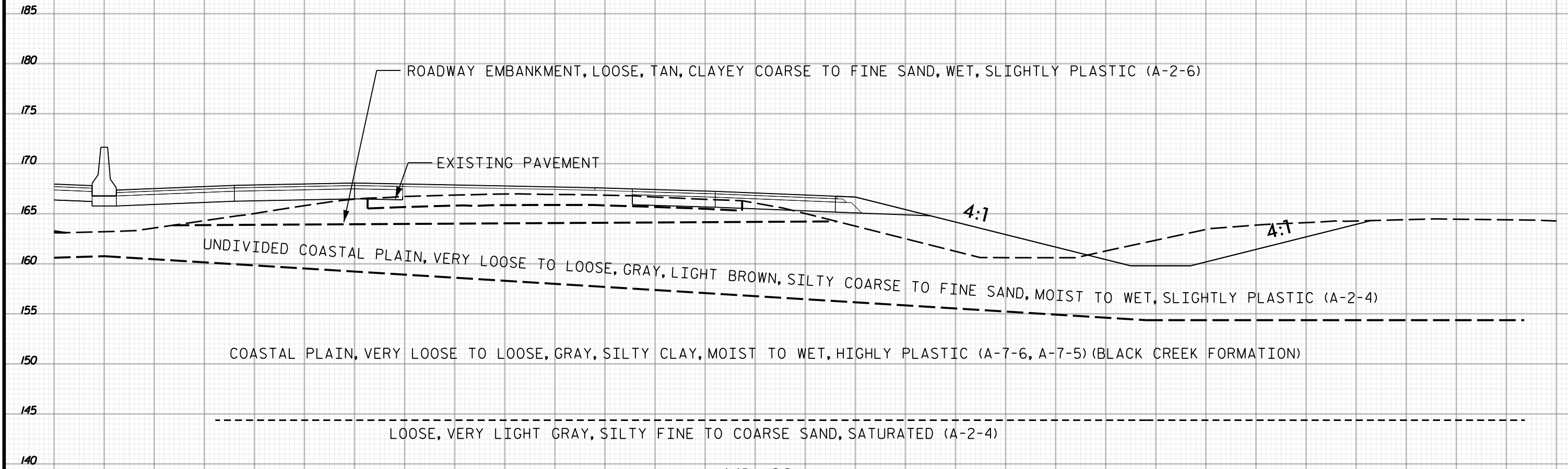

441+00  
2 OF 2

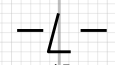

5 0 5 10 15 20 25 30 35 40 45 50 55 60 65 70 75 80 85 90 95 100 105 110 115 120 125 130 135 140 145



140 135 130 125 120 115 110 105 100 95 90 85 80 75 70 65 60 55 50 45 40 35 30 25 20 15 10 5 0 5

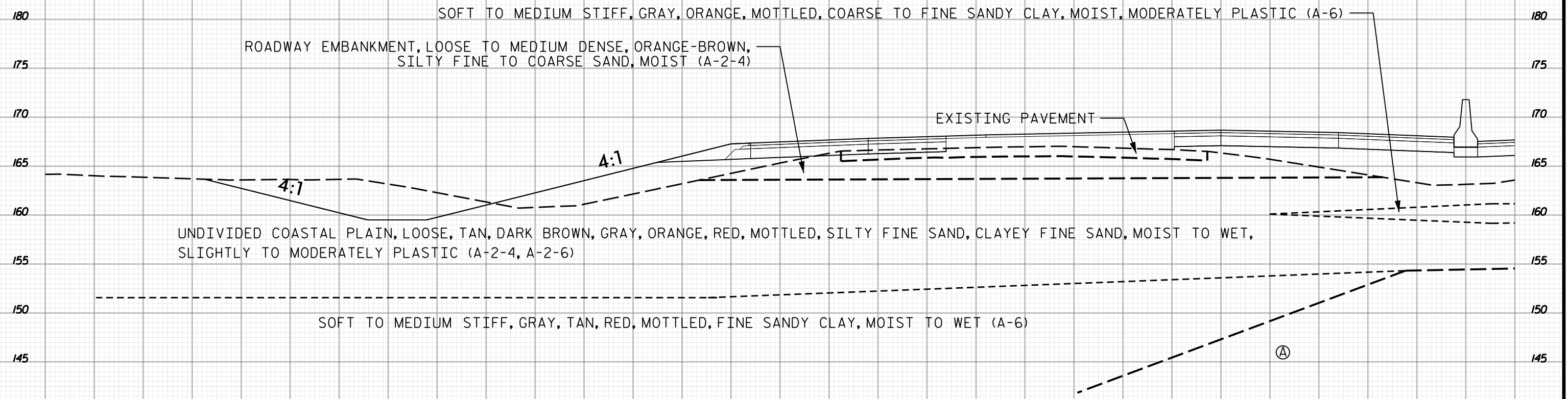

Ⓐ COASTAL PLAIN, LOOSE TO MEDIUM DENSE, LIGHT GRAY, RED, SILTY COARSE TO FINE SAND, COARSE SAND, SATURATED (A-2-4, A-3) (BLACK CREEK FORMATION)

441 + 50  
1 OF 2  
-L-

140 135 130 125 120 115 110 105 100 95 90 85 80 75 70 65 60 55 50 45 40 35 30 25 20 15 10 5 0 5



5 0 5 10 15 20 25 30 35 40 45 50 55 60 65 70 75 80 85 90 95 100 105 110 115 120 125 130 135 140 145

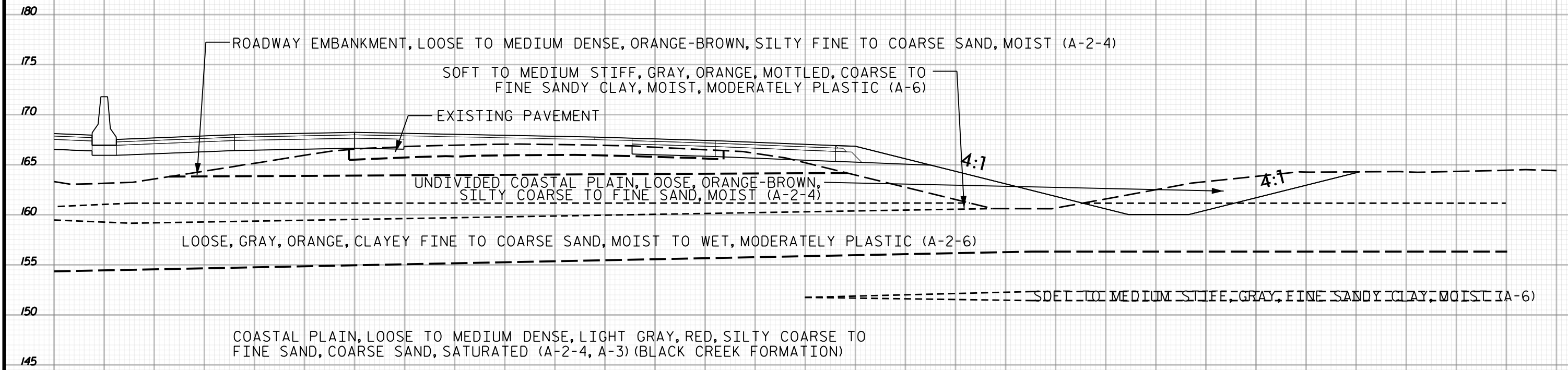

441+50  
2 OF 2

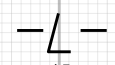

5 0 5 10 15 20 25 30 35 40 45 50 55 60 65 70 75 80 85 90 95 100 105 110 115 120 125 130 135 140 145



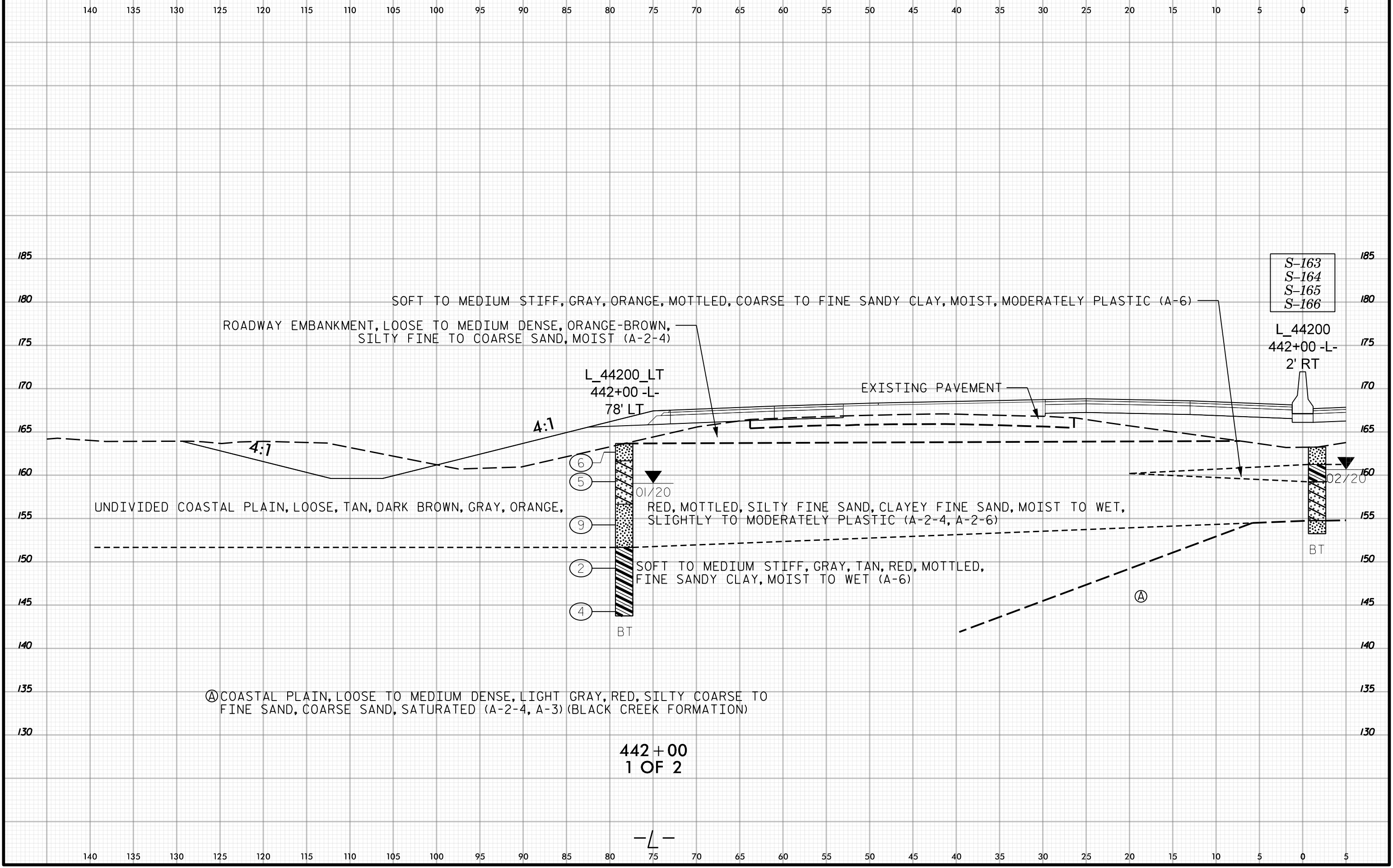
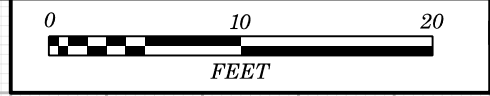

SOFT TO MEDIUM STIFF, GRAY, ORANGE, MOTTLED, COARSE TO FINE SANDY CLAY, MOIST, MODERATELY PLASTIC (A-6)

ROADWAY EMBANKMENT, LOOSE TO MEDIUM DENSE, ORANGE-BROWN, SILTY FINE TO COARSE SAND, MOIST (A-2-4)

L\_44200\_LT  
442+00 -L-  
78' LT

EXISTING PAVEMENT

S-163  
S-164  
S-165  
S-166

L\_44200  
442+00 -L-  
2' RT

UNDIVIDED COASTAL PLAIN, LOOSE, TAN, DARK BROWN, GRAY, ORANGE,

RED, MOTTLED, SILTY FINE SAND, CLAYEY FINE SAND, MOIST TO WET, SLIGHTLY TO MODERATELY PLASTIC (A-2-4, A-2-6)

SOFT TO MEDIUM STIFF, GRAY, TAN, RED, MOTTLED, FINE SANDY CLAY, MOIST TO WET (A-6)

Ⓐ COASTAL PLAIN, LOOSE TO MEDIUM DENSE, LIGHT GRAY, RED, SILTY COARSE TO FINE SAND, COARSE SAND, SATURATED (A-2-4, A-3) (BLACK CREEK FORMATION)

442+00  
1 OF 2

-L-

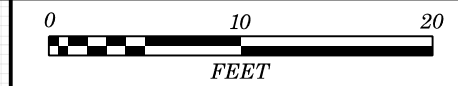

5 0 5 10 15 20 25 30 35 40 45 50 55 60 65 70 75 80 85 90 95 100 105 110 115 120 125 130 135 140 145

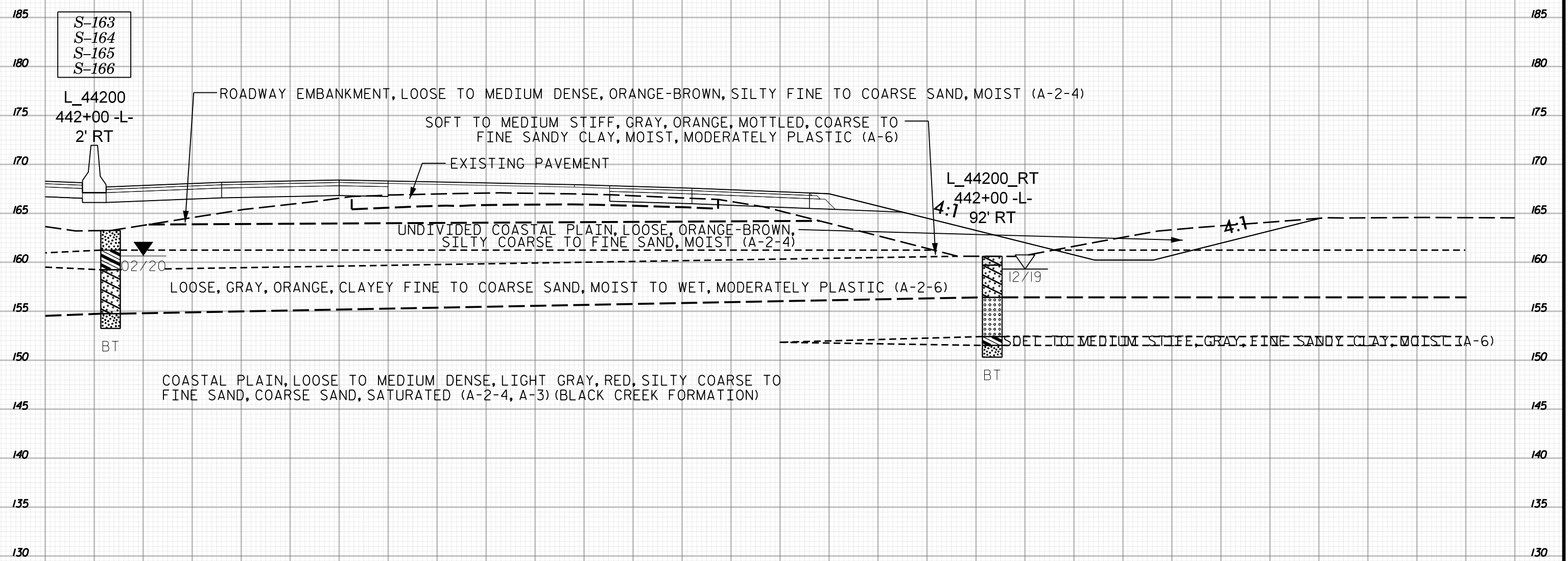

442+00  
2 OF 2

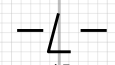

5 0 5 10 15 20 25 30 35 40 45 50 55 60 65 70 75 80 85 90 95 100 105 110 115 120 125 130 135 140 145



140 135 130 125 120 115 110 105 100 95 90 85 80 75 70 65 60 55 50 45 40 35 30 25 20 15 10 5 0 5

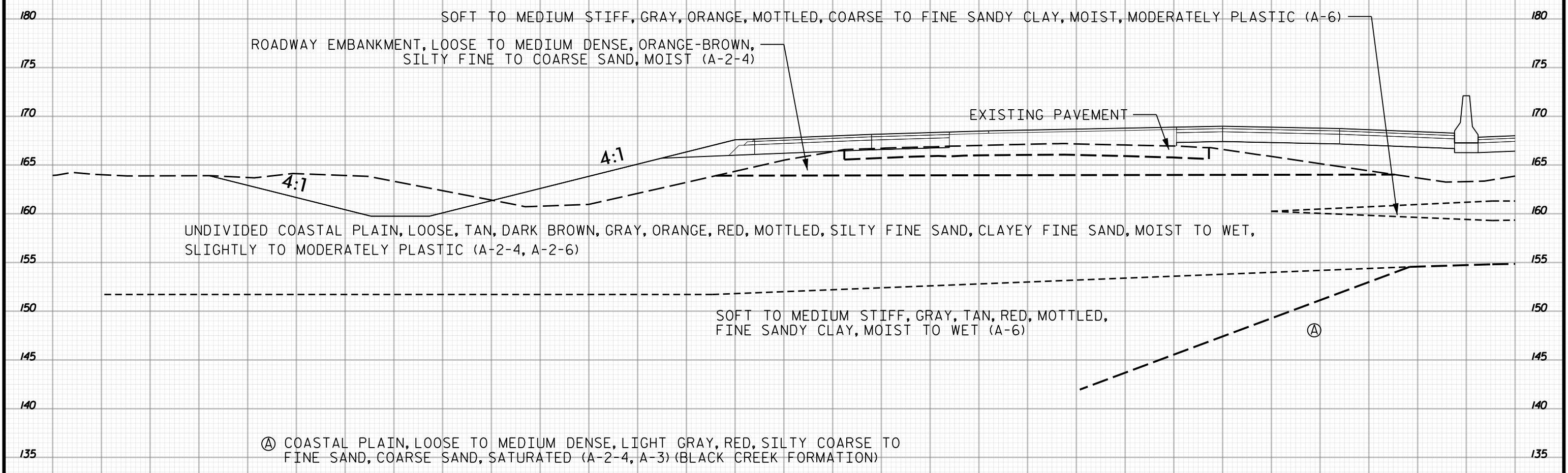

442 + 50  
1 OF 2

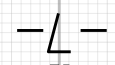

140 135 130 125 120 115 110 105 100 95 90 85 80 75 70 65 60 55 50 45 40 35 30 25 20 15 10 5 0 5



5 0 5 10 15 20 25 30 35 40 45 50 55 60 65 70 75 80 85 90 95 100 105 110 115 120 125 130 135 140 145

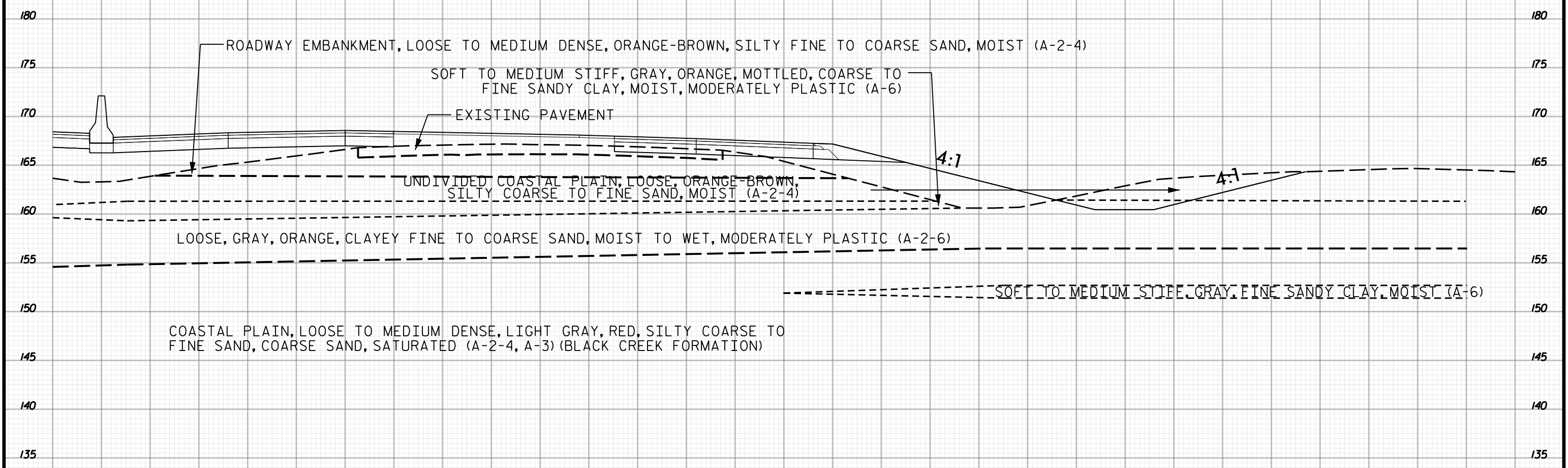

442 + 50  
2 OF 2

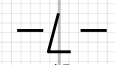

5 0 5 10 15 20 25 30 35 40 45 50 55 60 65 70 75 80 85 90 95 100 105 110 115 120 125 130 135 140 145



140 135 130 125 120 115 110 105 100 95 90 85 80 75 70 65 60 55 50 45 40 35 30 25 20 15 10 5 0 5

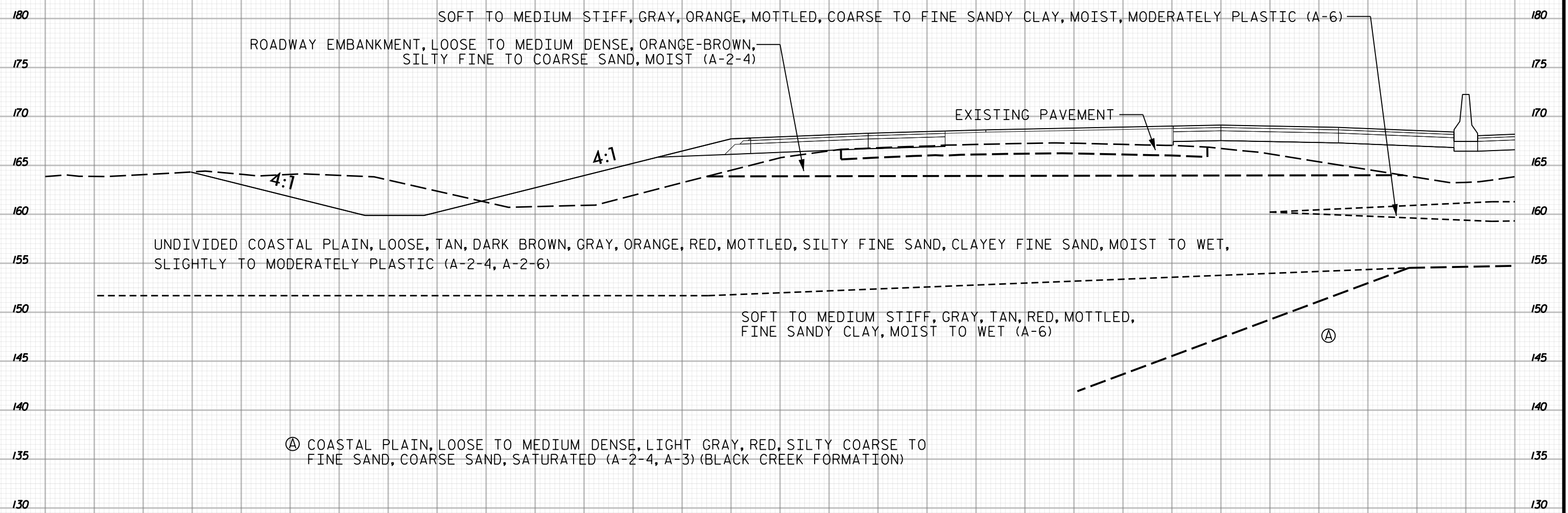

443+00  
1 OF 2

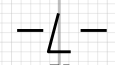

140 135 130 125 120 115 110 105 100 95 90 85 80 75 70 65 60 55 50 45 40 35 30 25 20 15 10 5 0 5

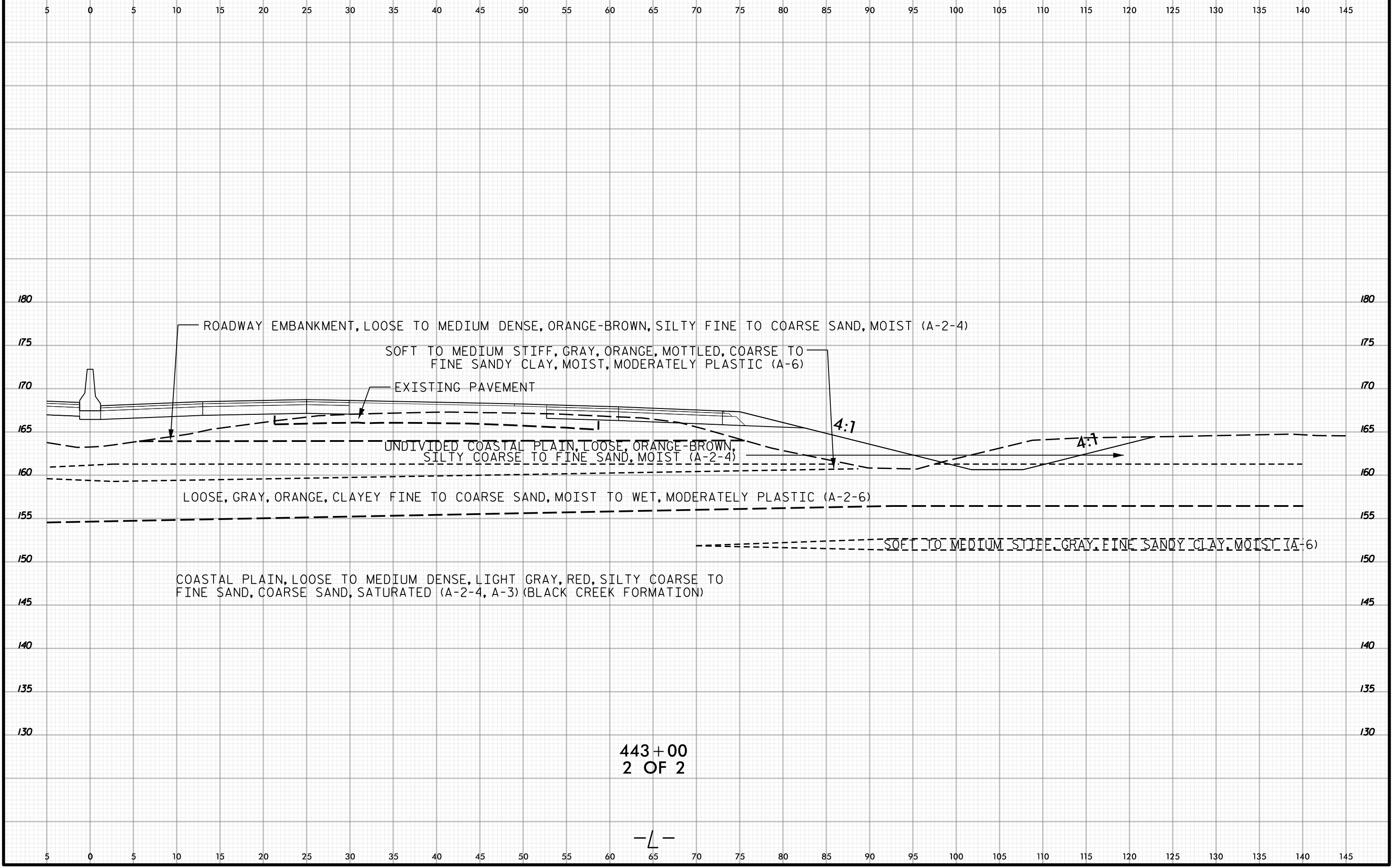

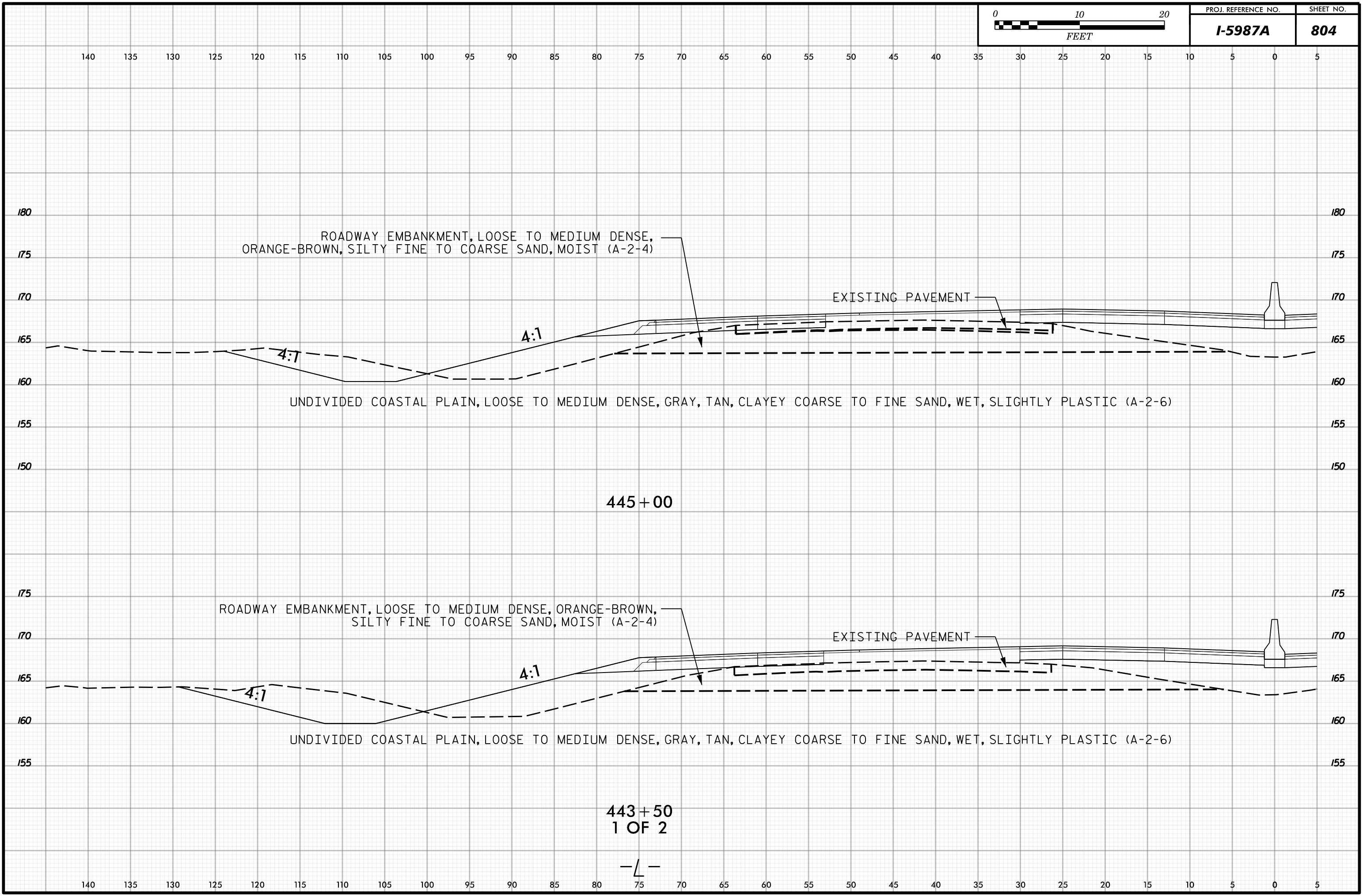



5 0 5 10 15 20 25 30 35 40 45 50 55 60 65 70 75 80 85 90 95 100 105 110 115 120 125 130 135 140 145

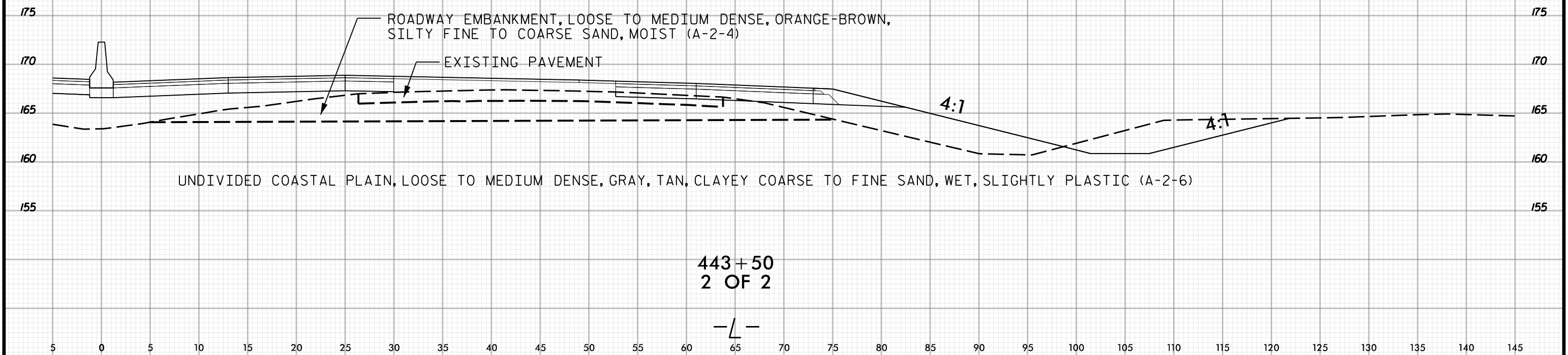
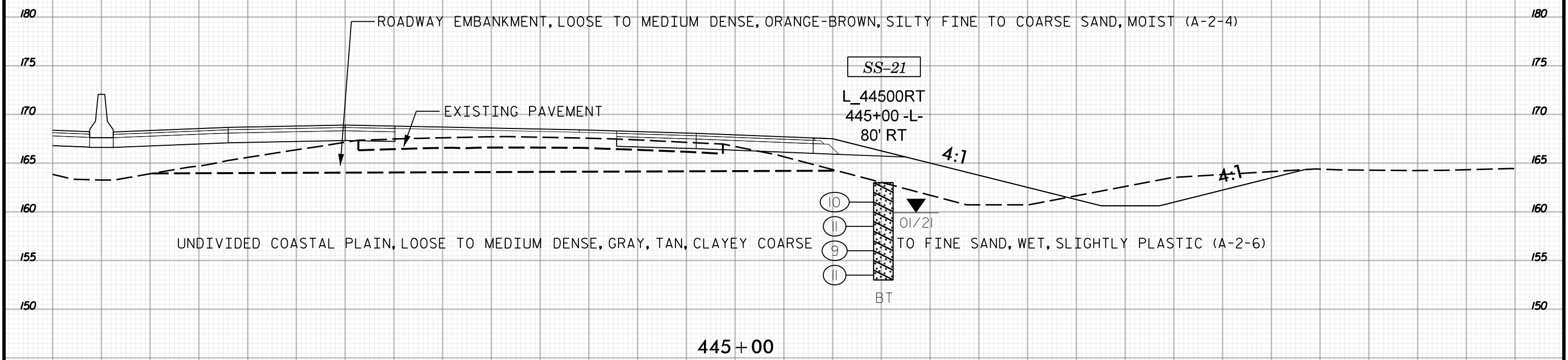



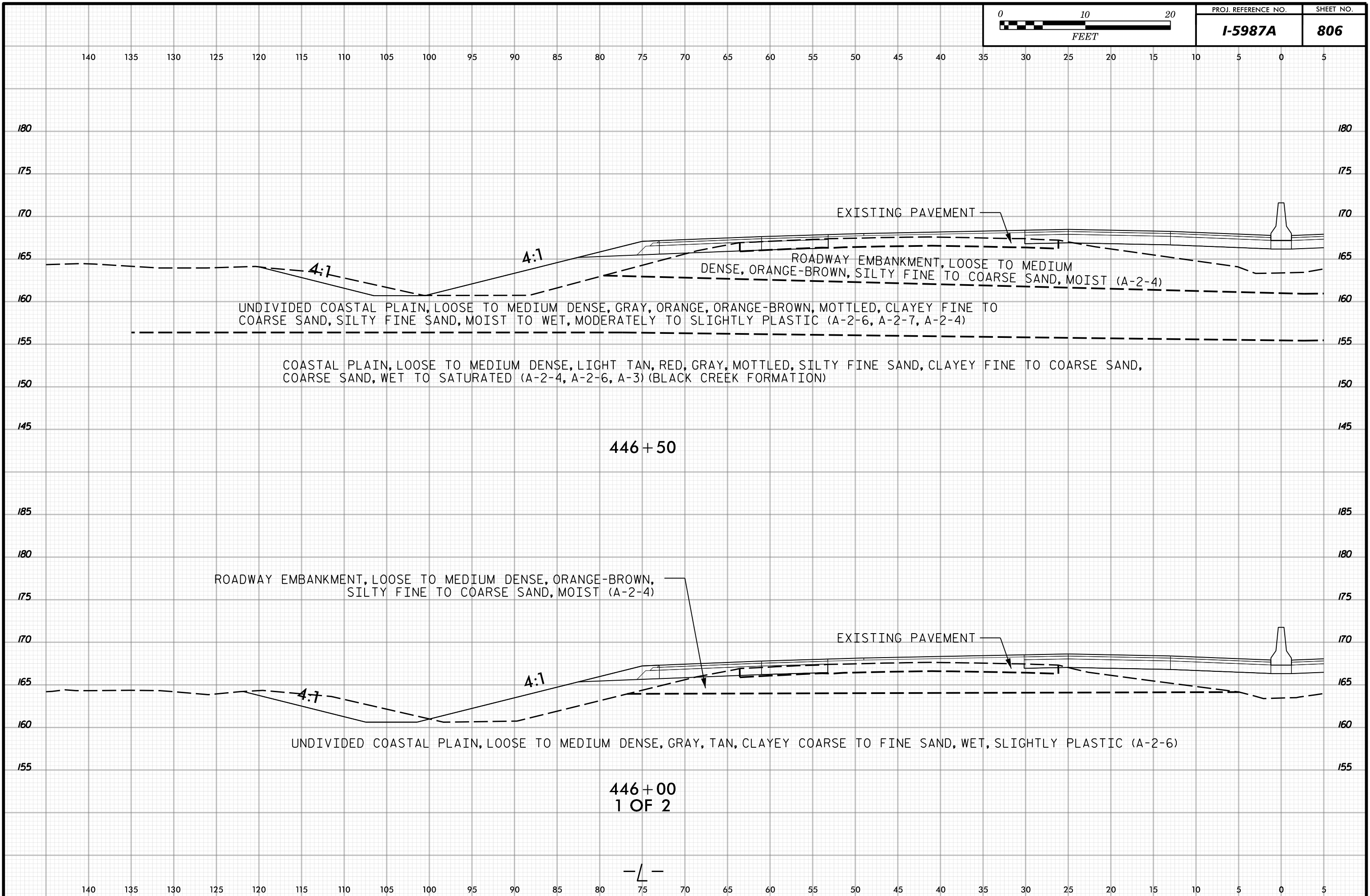



5 0 5 10 15 20 25 30 35 40 45 50 55 60 65 70 75 80 85 90 95 100 105 110 115 120 125 130 135 140 145

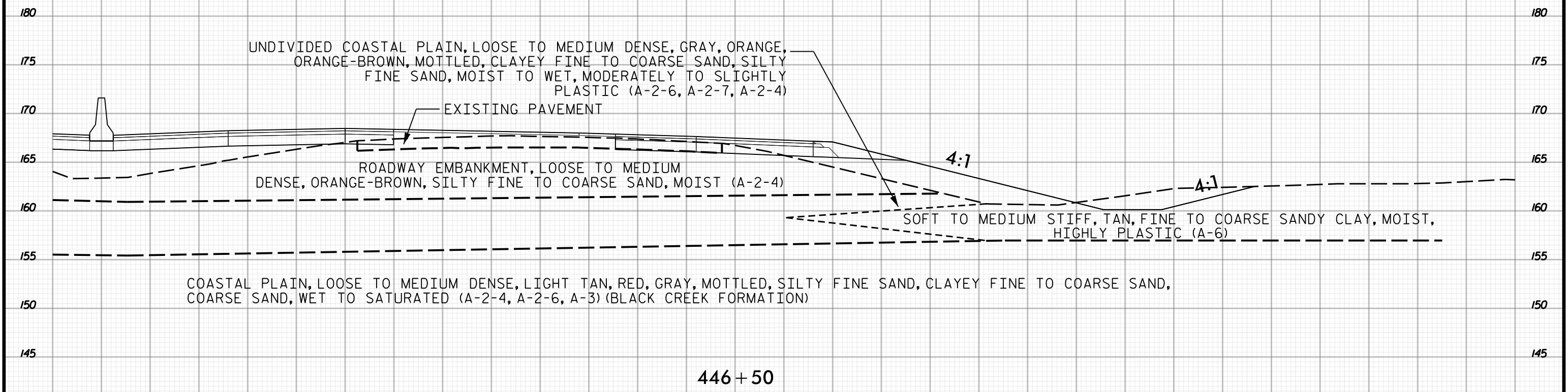

446 + 50

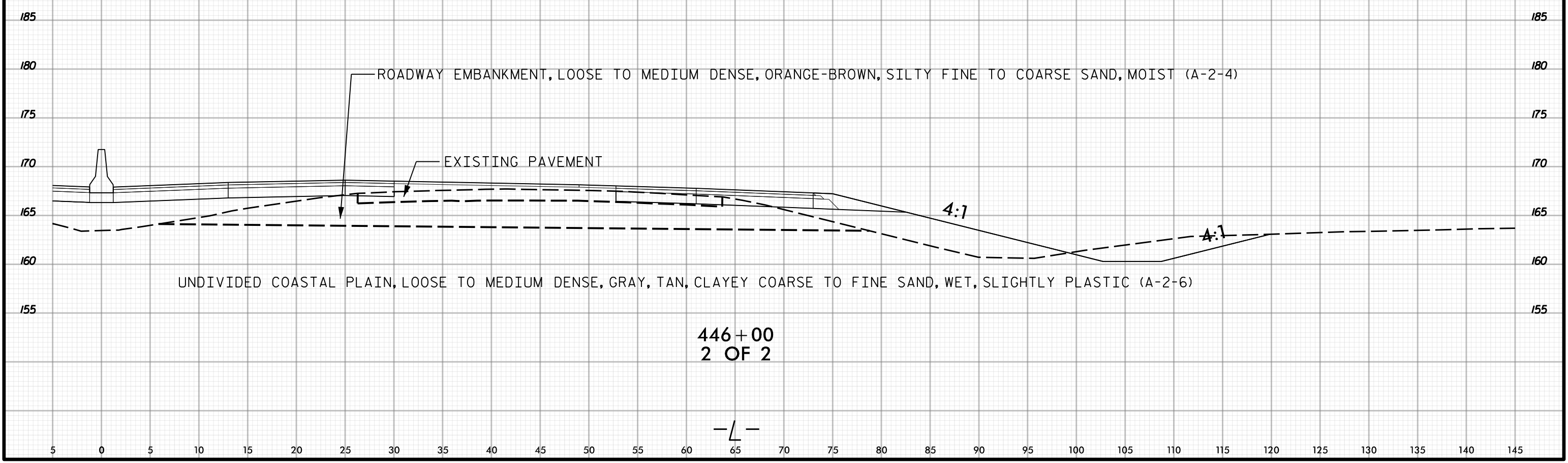

446 + 00  
2 OF 2

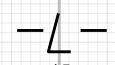

5 0 5 10 15 20 25 30 35 40 45 50 55 60 65 70 75 80 85 90 95 100 105 110 115 120 125 130 135 140 145

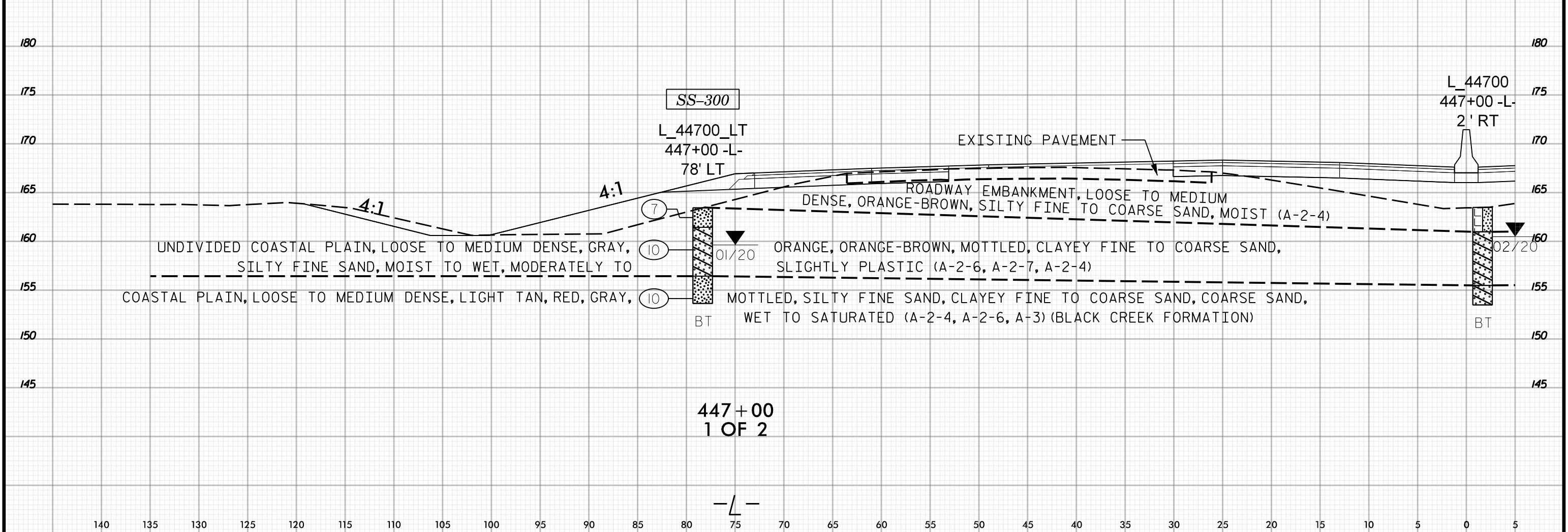
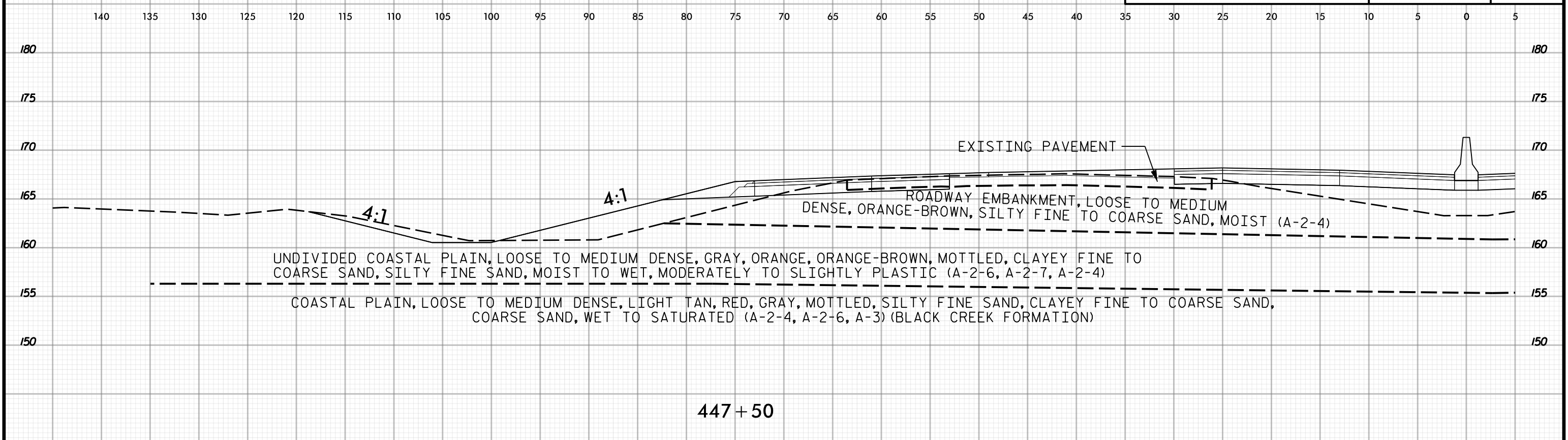

447+00  
1 OF 2

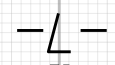

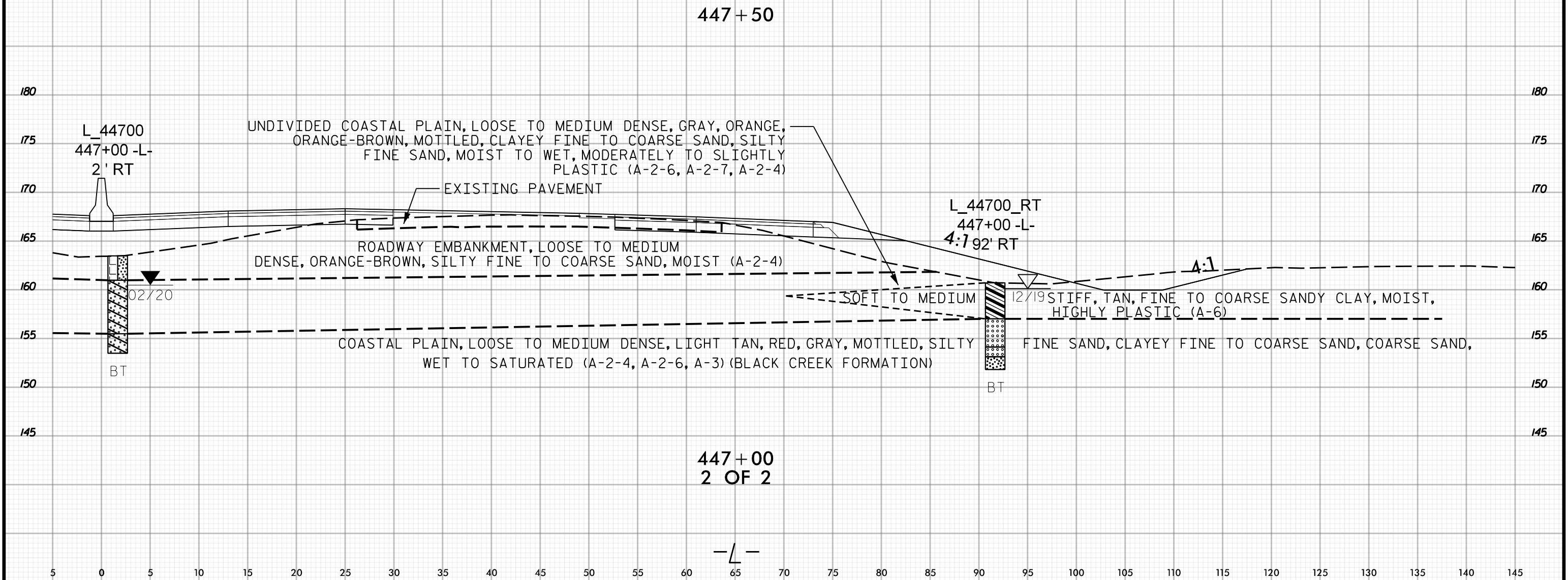
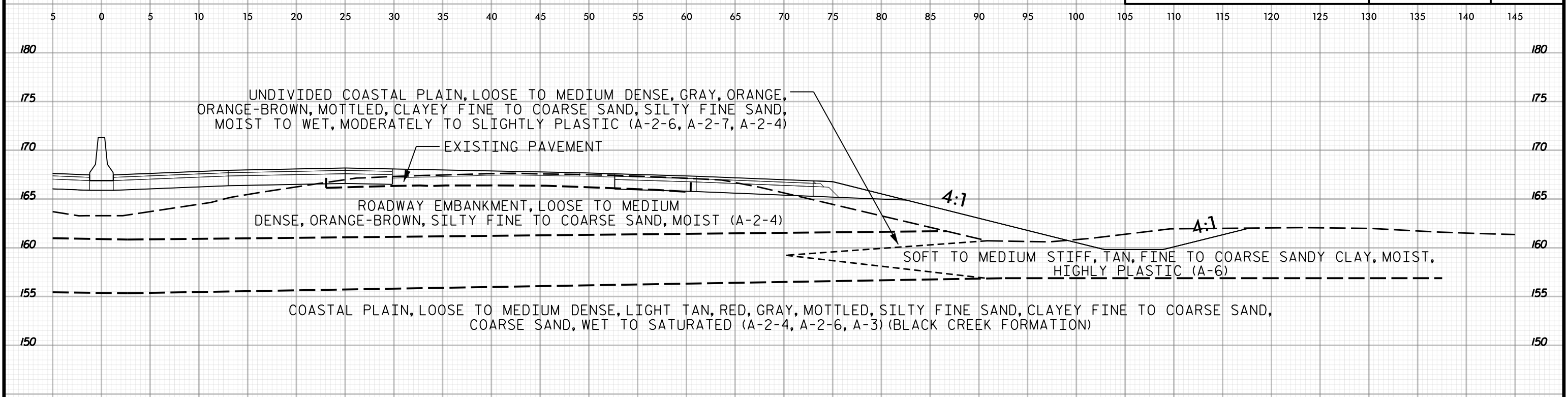
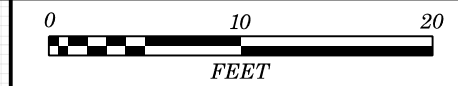



140 135 130 125 120 115 110 105 100 95 90 85 80 75 70 65 60 55 50 45 40 35 30 25 20 15 10 5 0 5

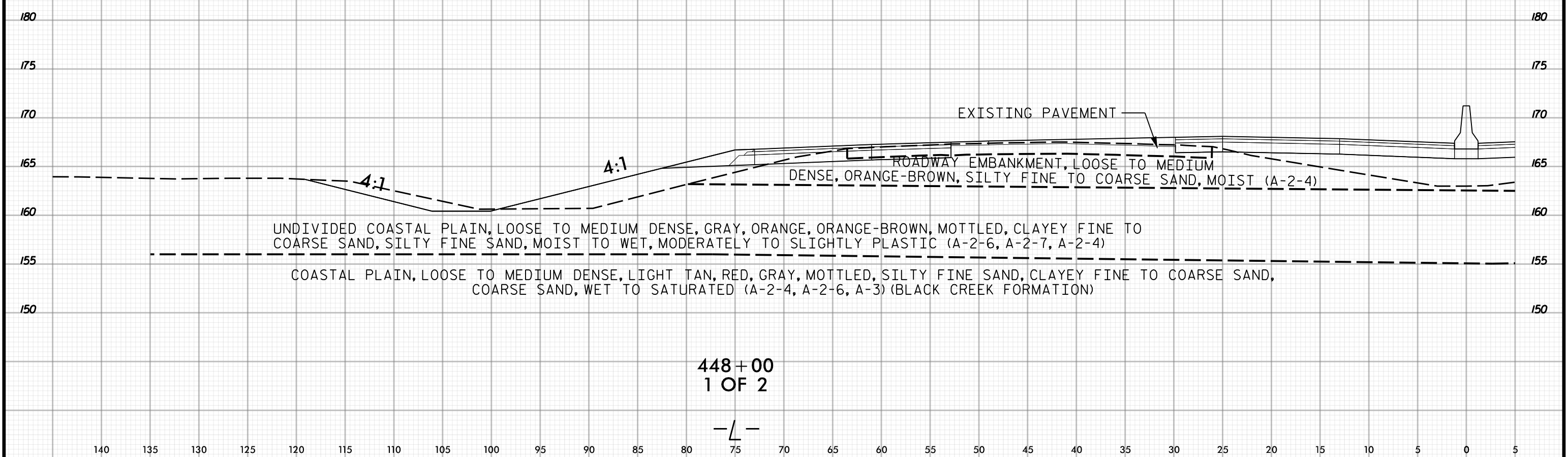
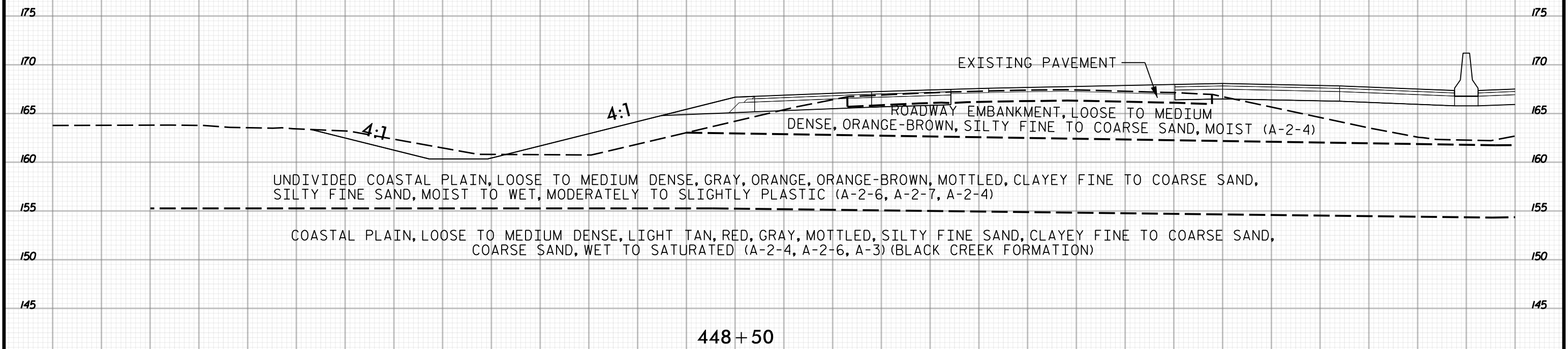

140 135 130 125 120 115 110 105 100 95 90 85 80 75 70 65 60 55 50 45 40 35 30 25 20 15 10 5 0 5



5 0 5 10 15 20 25 30 35 40 45 50 55 60 65 70 75 80 85 90 95 100 105 110 115 120 125 130 135 140 145

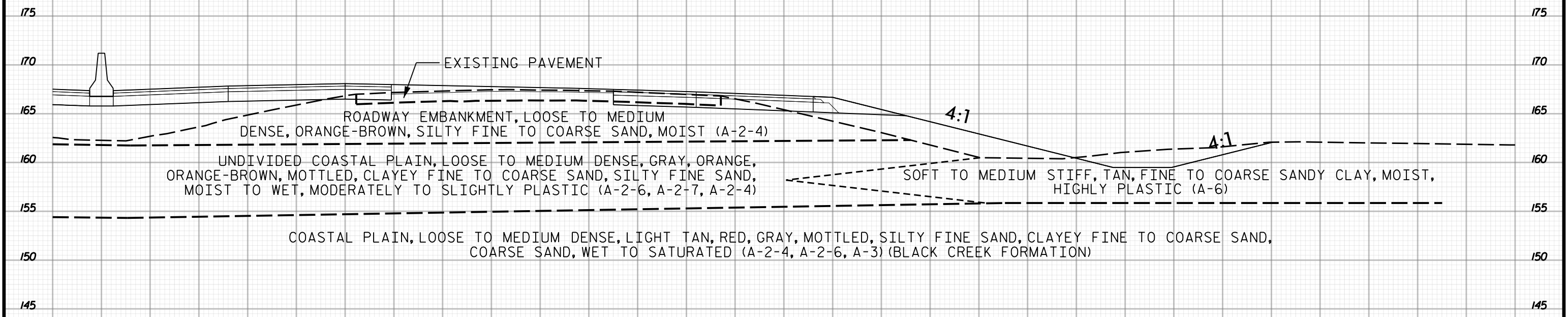

448 + 50

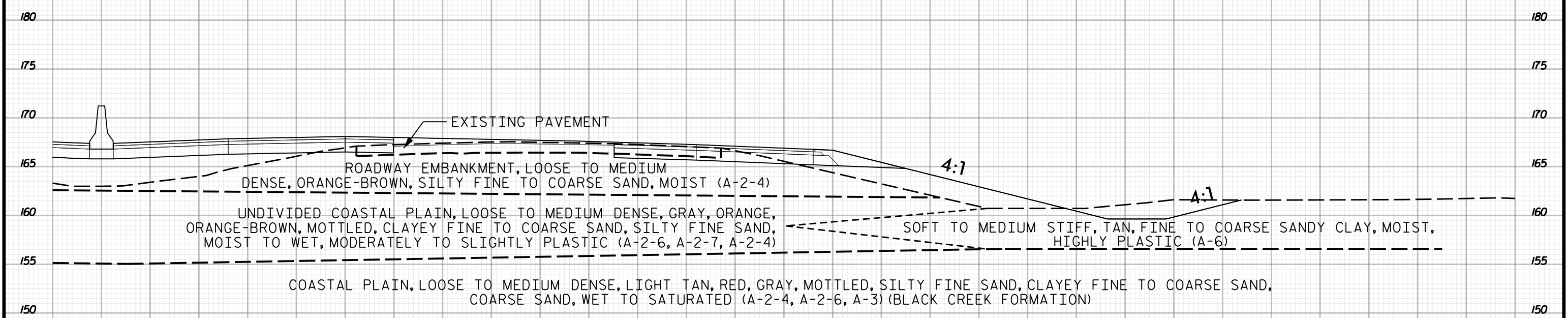

448 + 00  
2 OF 2

5 0 5 10 15 20 25 30 35 40 45 50 55 60 65 70 75 80 85 90 95 100 105 110 115 120 125 130 135 140 145



140 135 130 125 120 115 110 105 100 95 90 85 80 75 70 65 60 55 50 45 40 35 30 25 20 15 10 5 0 5



449 + 50

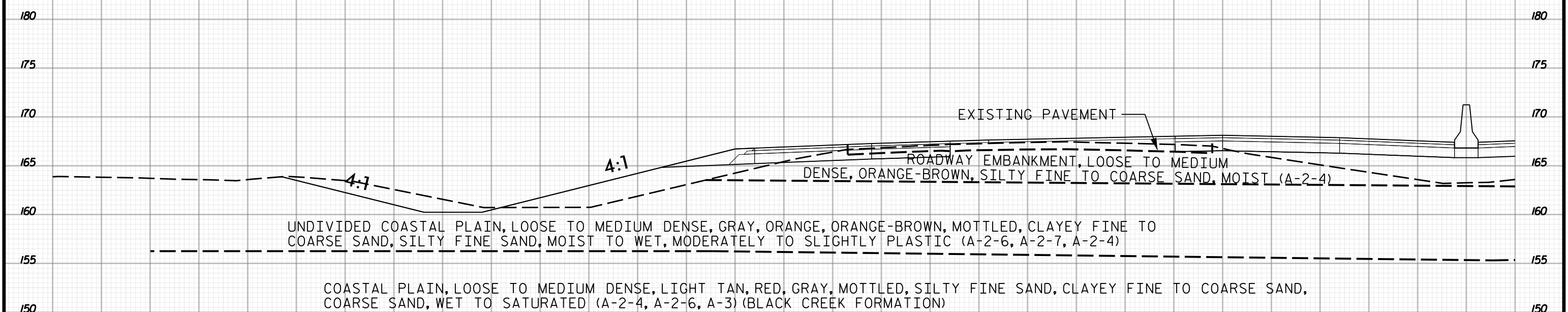

449 + 00  
1 OF 2

140 135 130 125 120 115 110 105 100 95 90 85 80 75 70 65 60 55 50 45 40 35 30 25 20 15 10 5 0 5



5 0 5 10 15 20 25 30 35 40 45 50 55 60 65 70 75 80 85 90 95 100 105 110 115 120 125 130 135 140 145

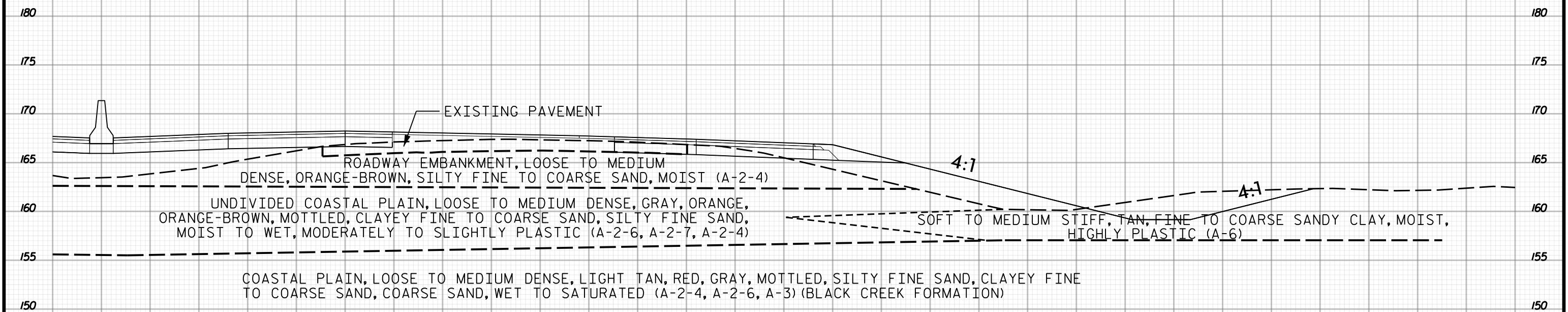

449 + 50

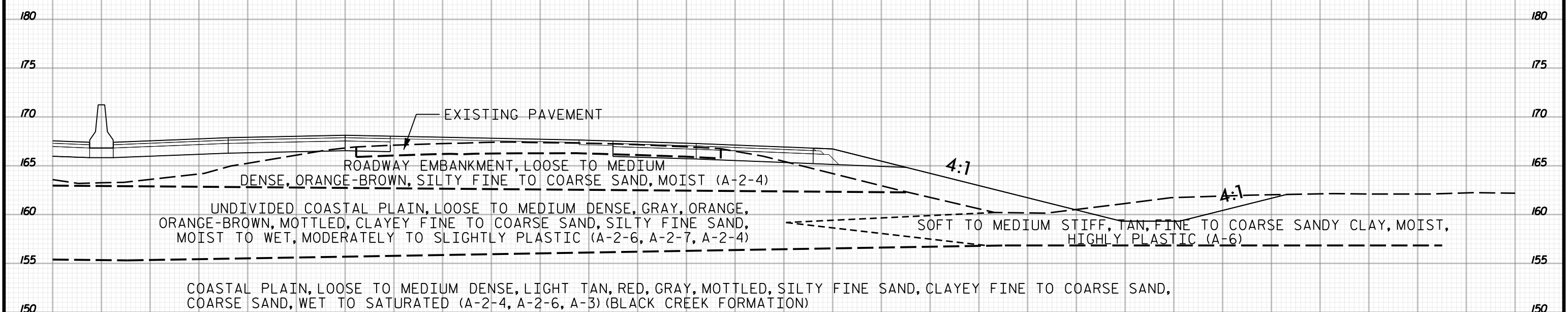

449 + 00  
2 OF 2

5 0 5 10 15 20 25 30 35 40 45 50 55 60 65 70 75 80 85 90 95 100 105 110 115 120 125 130 135 140 145

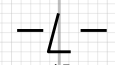





140 135 130 125 120 115 110 105 100 95 90 85 80 75 70 65 60 55 50 45 40 35 30 25 20 15 10 5 0 5

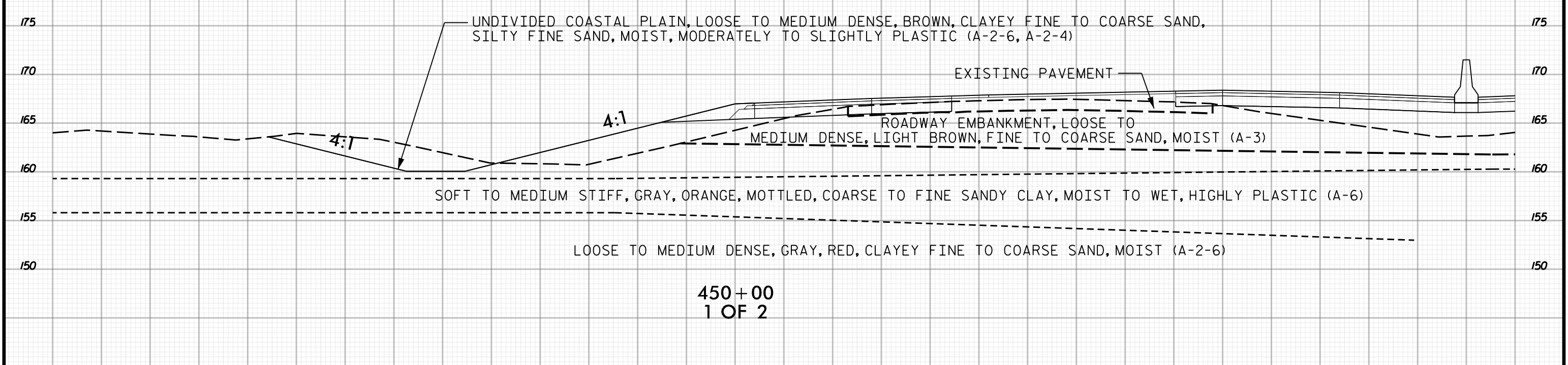
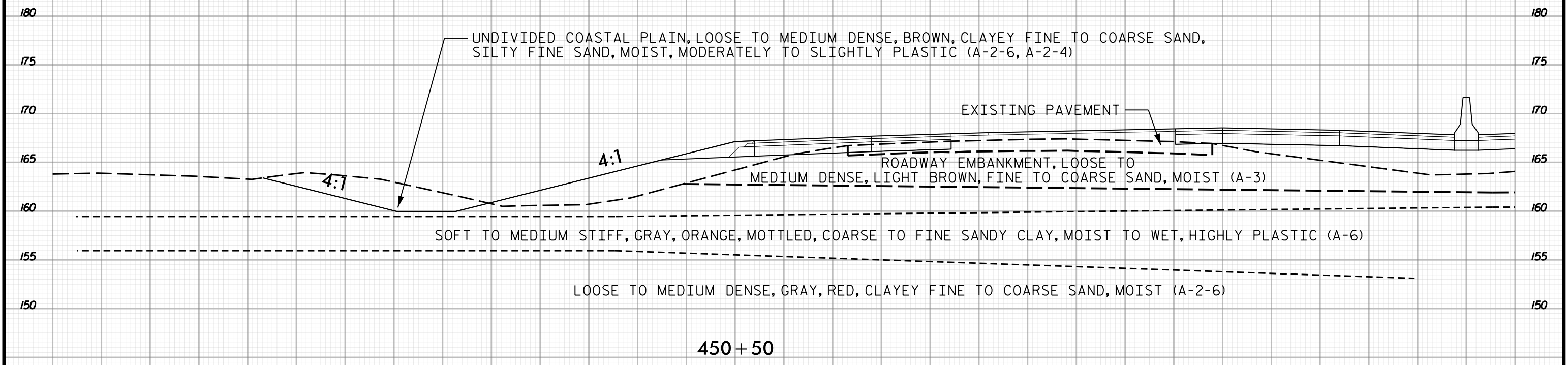

140 135 130 125 120 115 110 105 100 95 90 85 80 75 70 65 60 55 50 45 40 35 30 25 20 15 10 5 0 5

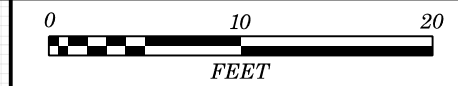

5 0 5 10 15 20 25 30 35 40 45 50 55 60 65 70 75 80 85 90 95 100 105 110 115 120 125 130 135 140 145

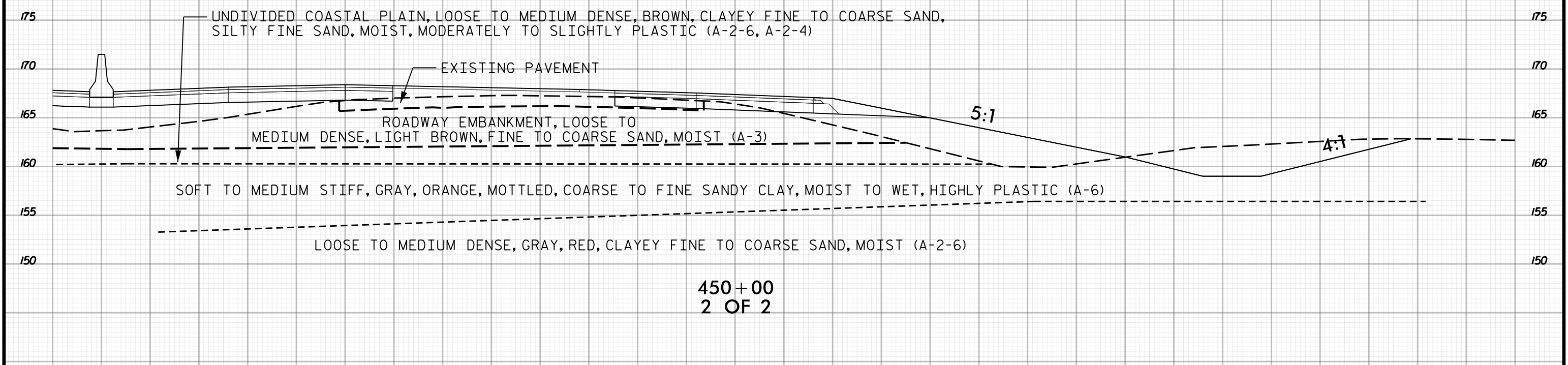
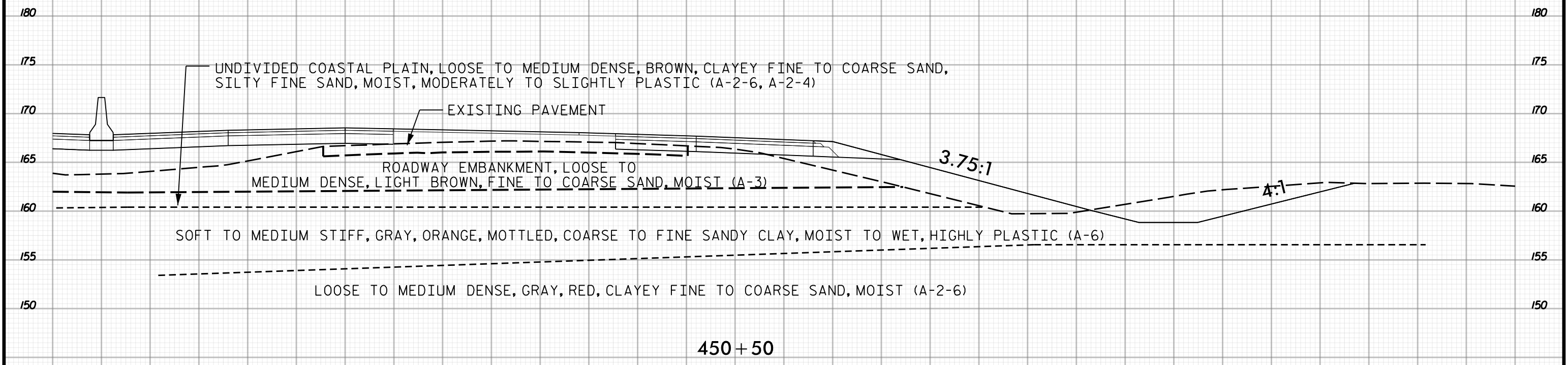

5 0 5 10 15 20 25 30 35 40 45 50 55 60 65 70 75 80 85 90 95 100 105 110 115 120 125 130 135 140 145

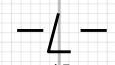



140 135 130 125 120 115 110 105 100 95 90 85 80 75 70 65 60 55 50 45 40 35 30 25 20 15 10 5 0 5

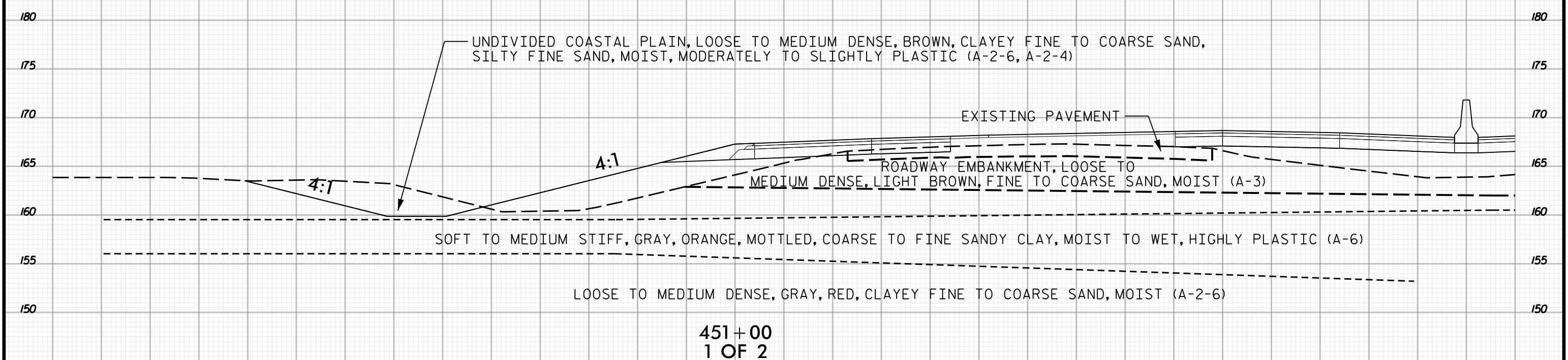
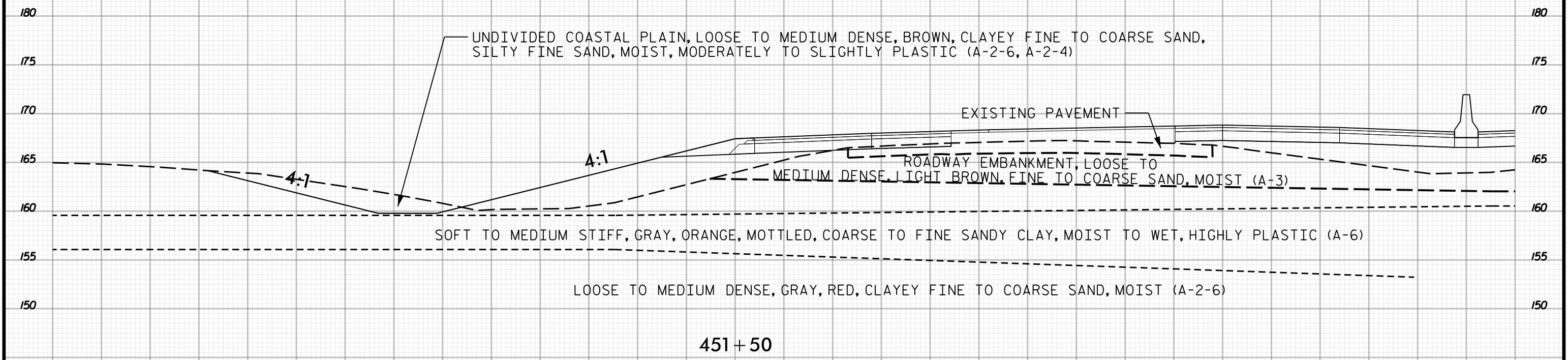

140 135 130 125 120 115 110 105 100 95 90 85 80 75 70 65 60 55 50 45 40 35 30 25 20 15 10 5 0 5

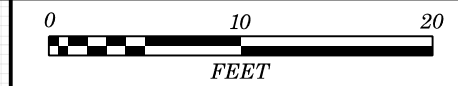

5 0 5 10 15 20 25 30 35 40 45 50 55 60 65 70 75 80 85 90 95 100 105 110 115 120 125 130 135 140 145

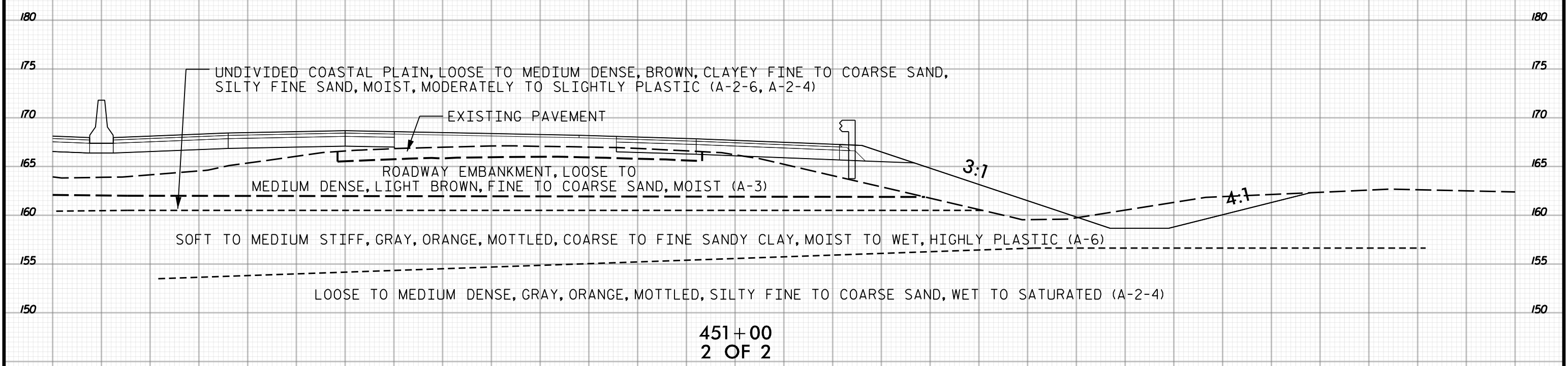
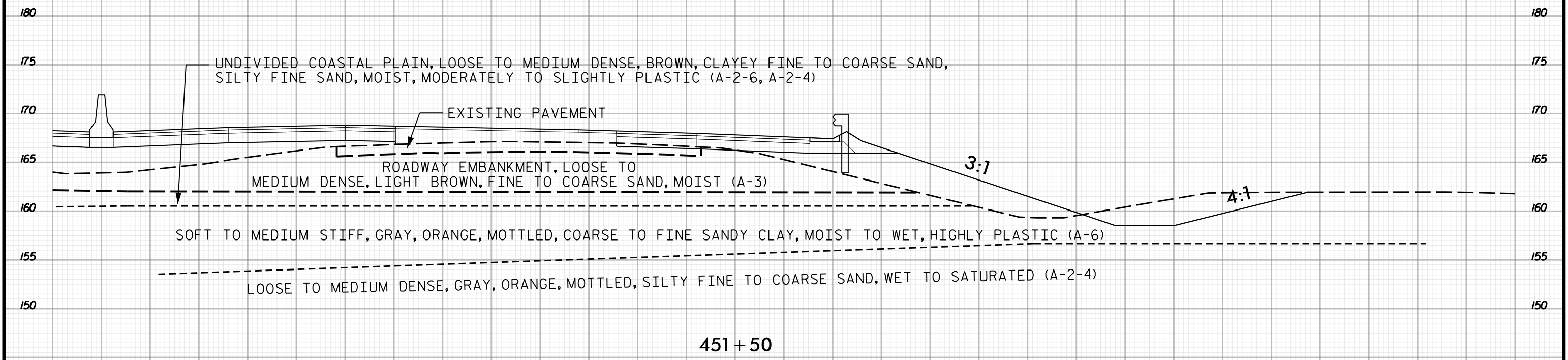

5 0 5 10 15 20 25 30 35 40 45 50 55 60 65 70 75 80 85 90 95 100 105 110 115 120 125 130 135 140 145



140 135 130 125 120 115 110 105 100 95 90 85 80 75 70 65 60 55 50 45 40 35 30 25 20 15 10 5 0 5

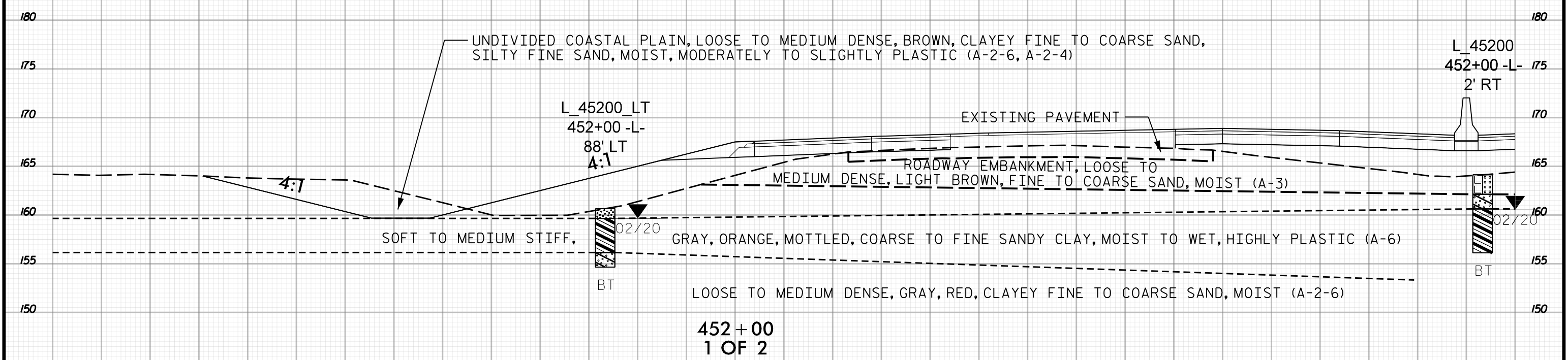
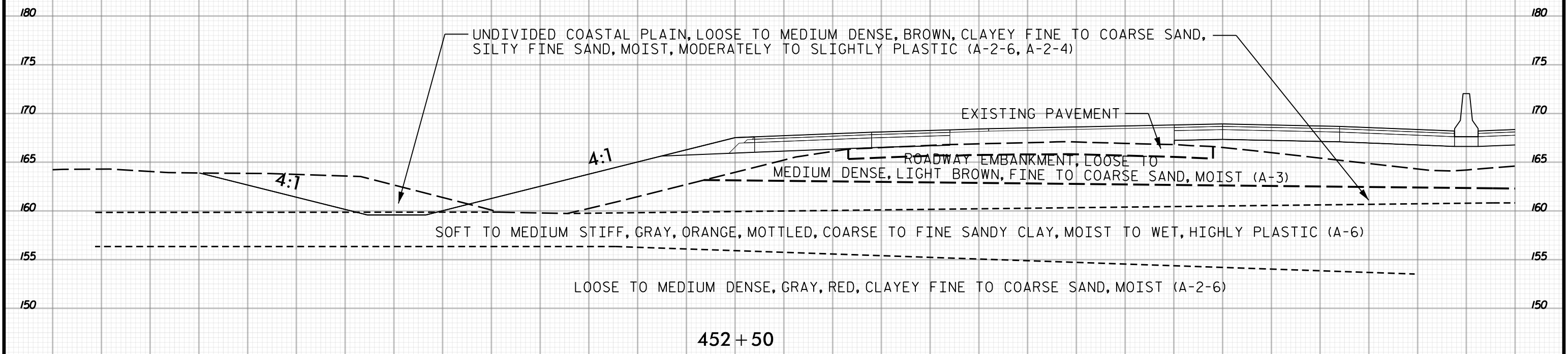

140 135 130 125 120 115 110 105 100 95 90 85 80 75 70 65 60 55 50 45 40 35 30 25 20 15 10 5 0 5



5 0 5 10 15 20 25 30 35 40 45 50 55 60 65 70 75 80 85 90 95 100 105 110 115 120 125 130 135 140 145

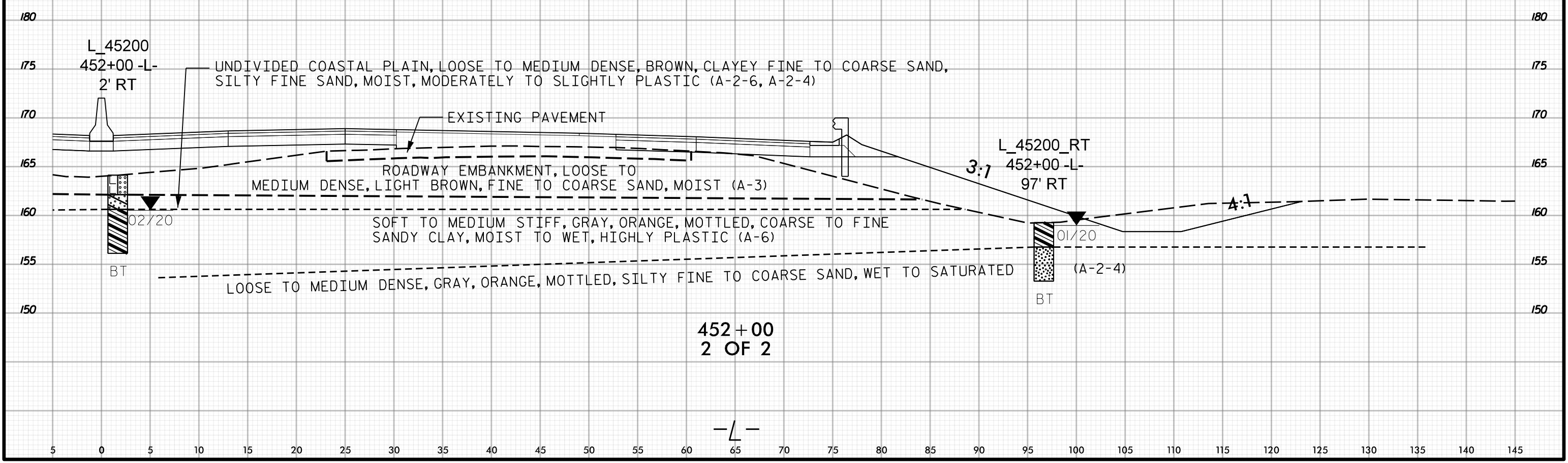
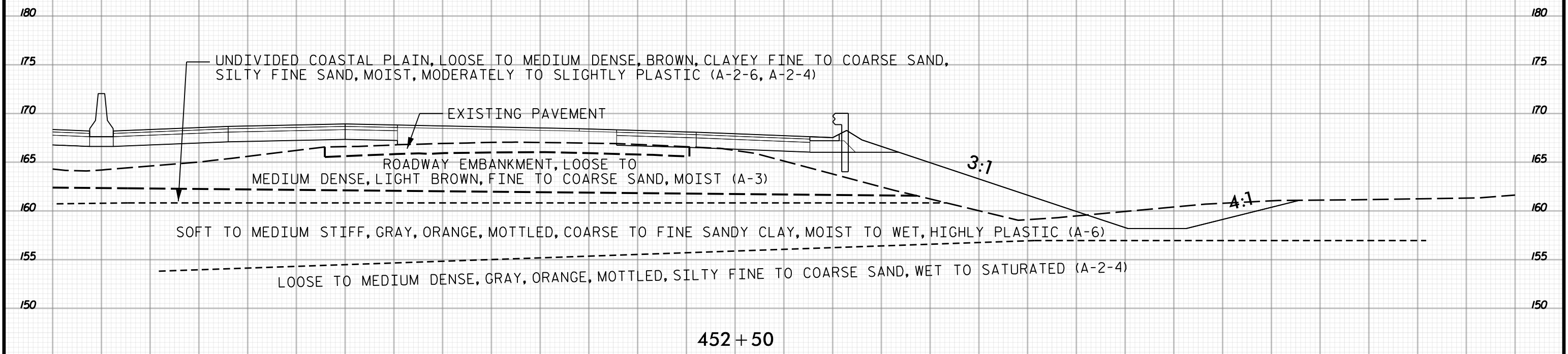

5 0 5 10 15 20 25 30 35 40 45 50 55 60 65 70 75 80 85 90 95 100 105 110 115 120 125 130 135 140 145



140 135 130 125 120 115 110 105 100 95 90 85 80 75 70 65 60 55 50 45 40 35 30 25 20 15 10 5 0 5

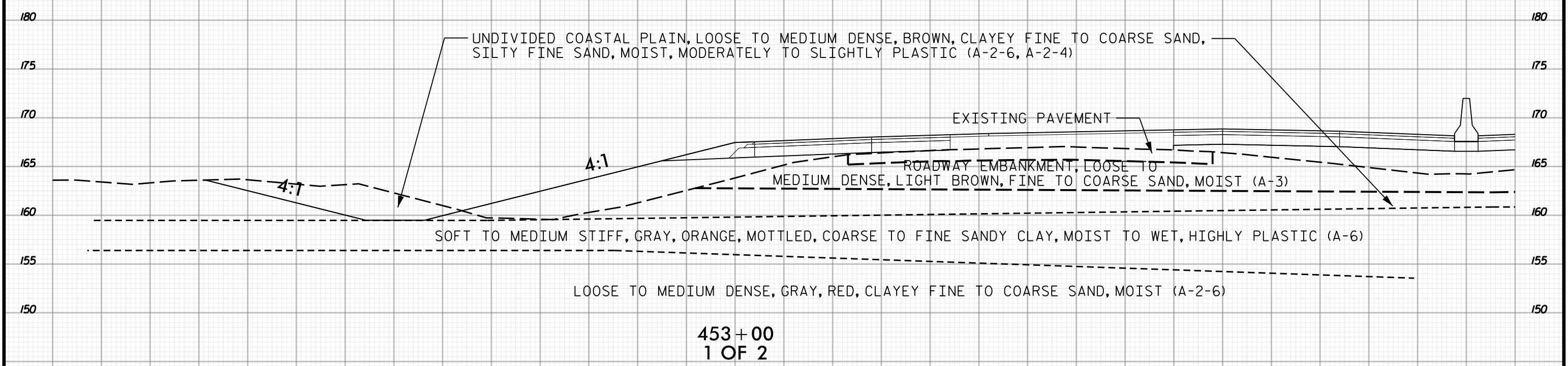
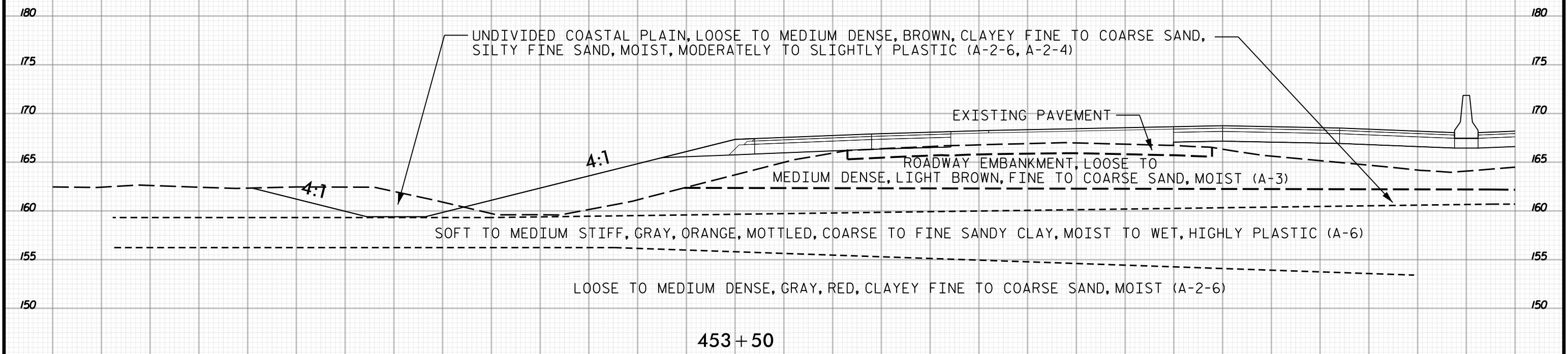

140 135 130 125 120 115 110 105 100 95 90 85 80 75 70 65 60 55 50 45 40 35 30 25 20 15 10 5 0 5

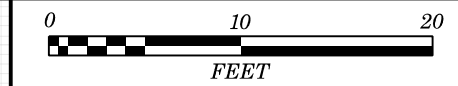

5 0 5 10 15 20 25 30 35 40 45 50 55 60 65 70 75 80 85 90 95 100 105 110 115 120 125 130 135 140 145

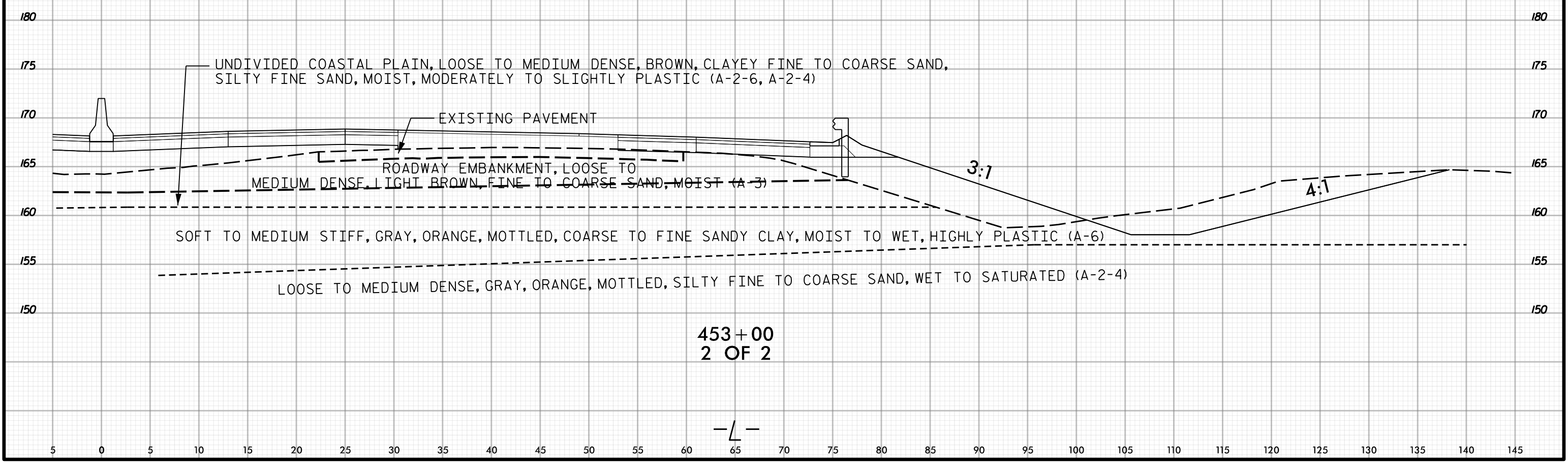
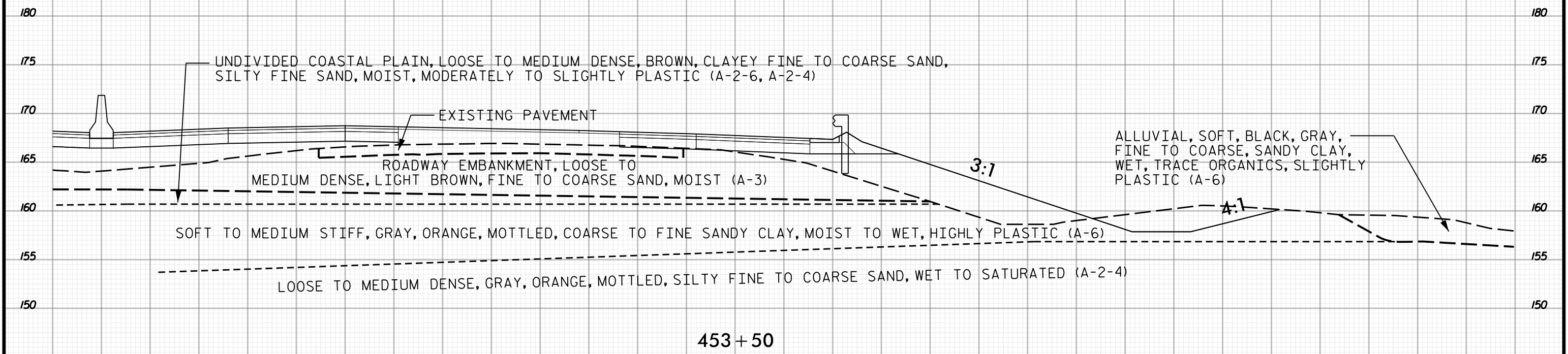

5 0 5 10 15 20 25 30 35 40 45 50 55 60 65 70 75 80 85 90 95 100 105 110 115 120 125 130 135 140 145





140 135 130 125 120 115 110 105 100 95 90 85 80 75 70 65 60 55 50 45 40 35 30 25 20 15 10 5 0 5

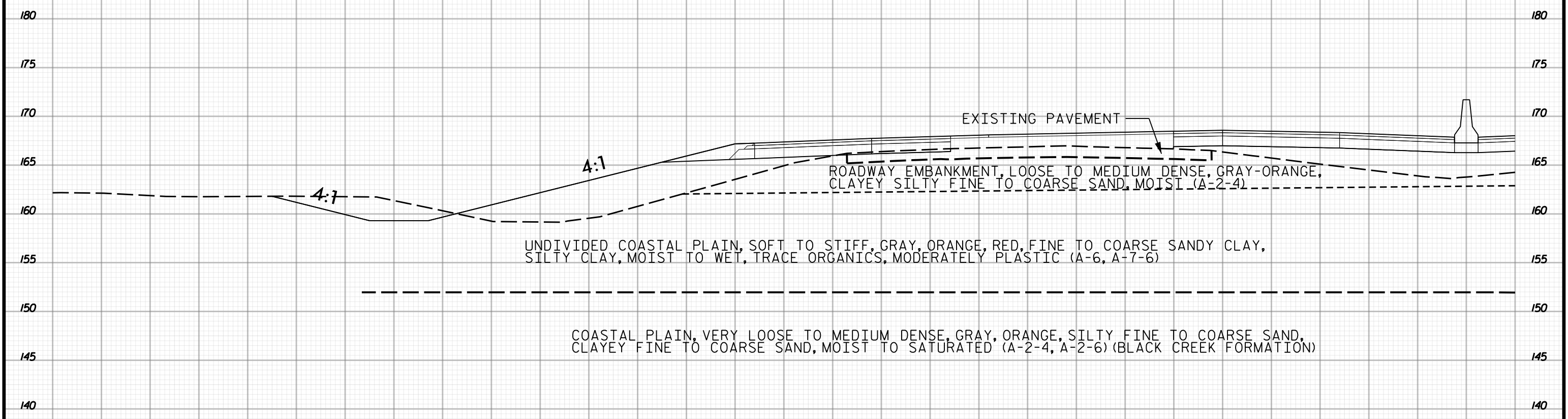

454+00  
1 OF 2

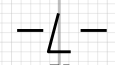

140 135 130 125 120 115 110 105 100 95 90 85 80 75 70 65 60 55 50 45 40 35 30 25 20 15 10 5 0 5

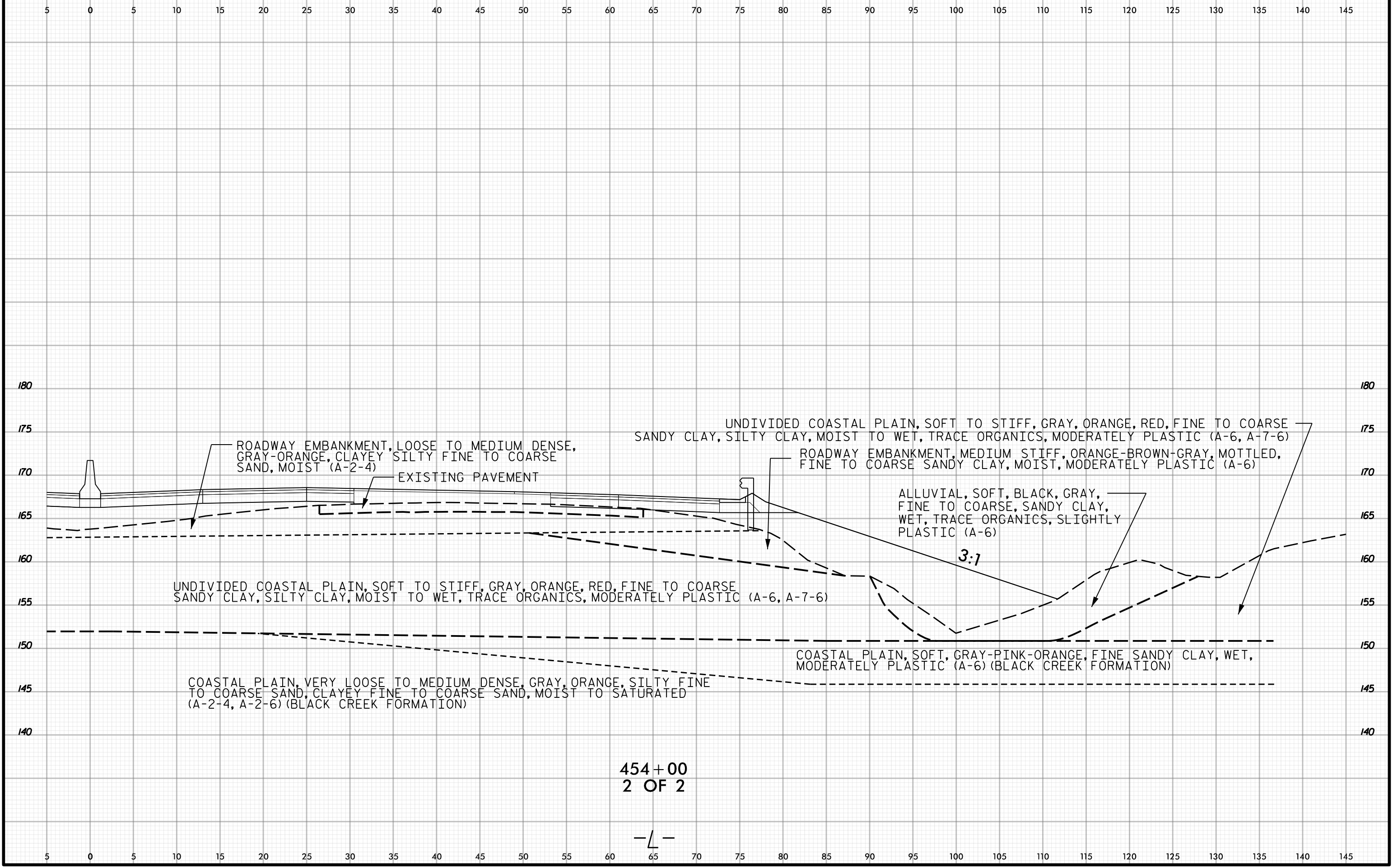
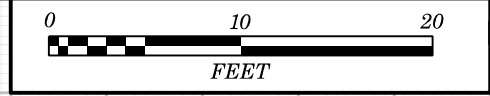

454+00  
2 OF 2

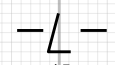

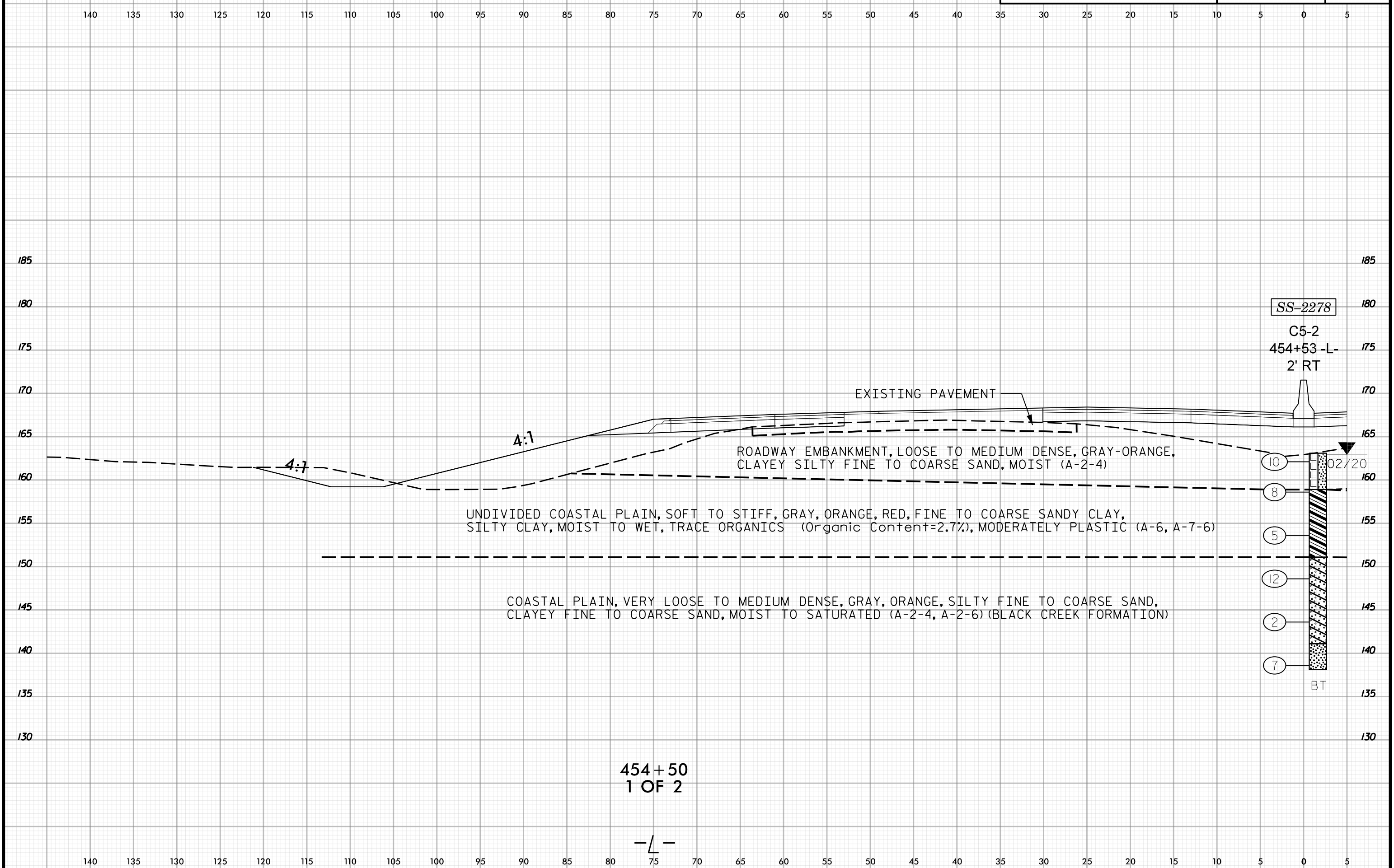



5 0 5 10 15 20 25 30 35 40 45 50 55 60 65 70 75 80 85 90 95 100 105 110 115 120 125 130 135 140 145

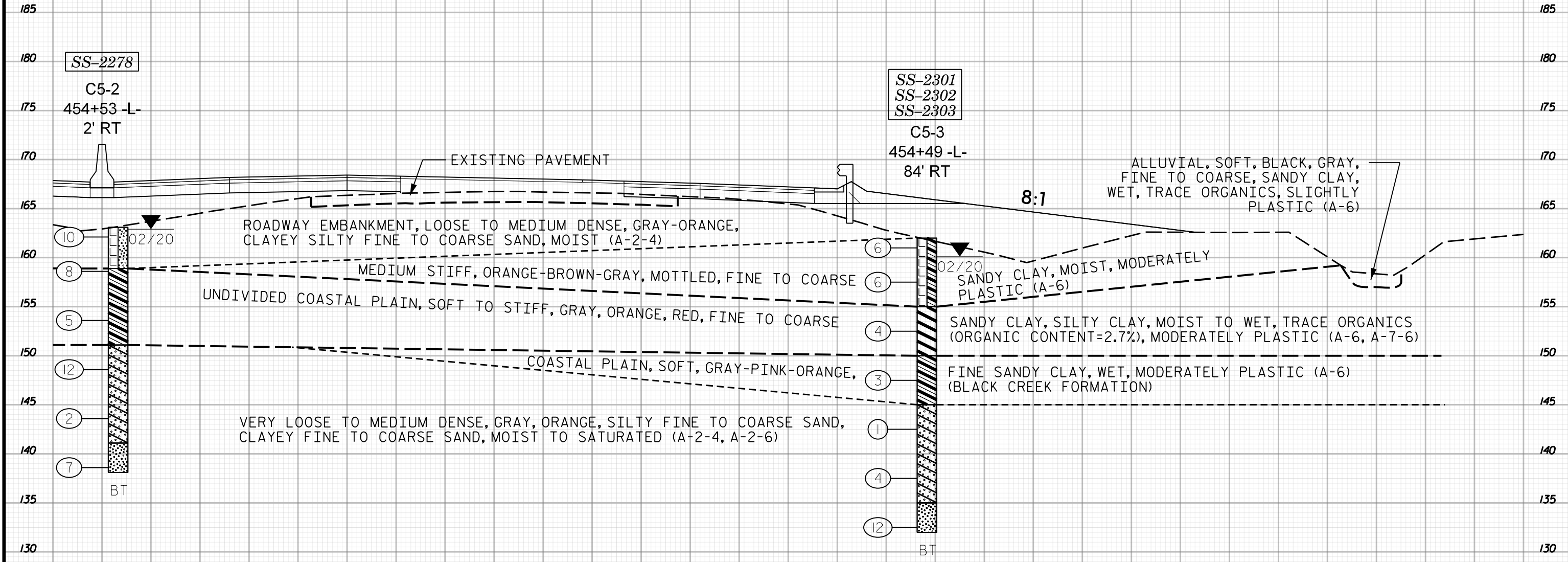

454+50  
2 OF 2

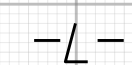

5 0 5 10 15 20 25 30 35 40 45 50 55 60 65 70 75 80 85 90 95 100 105 110 115 120 125 130 135 140 145

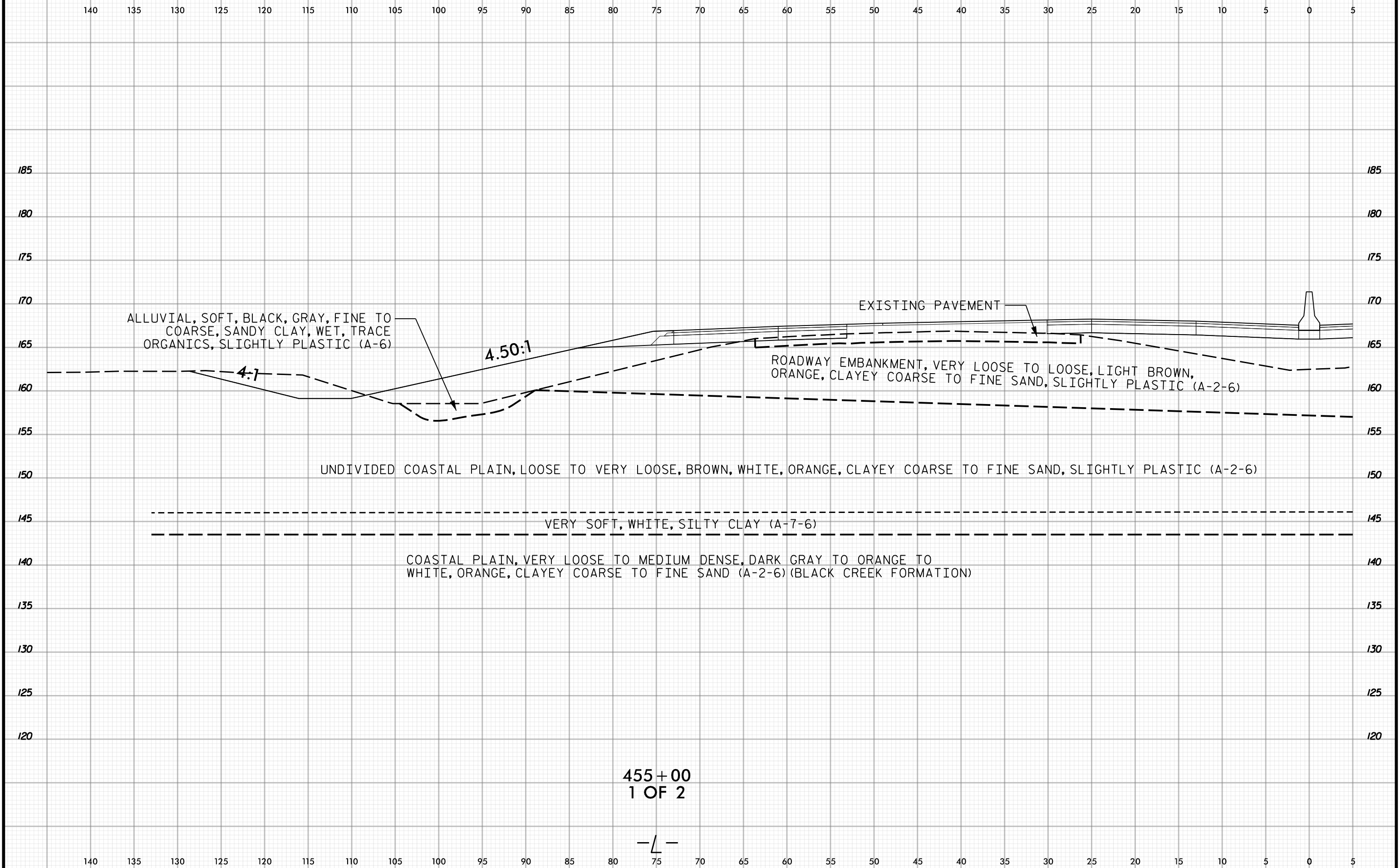

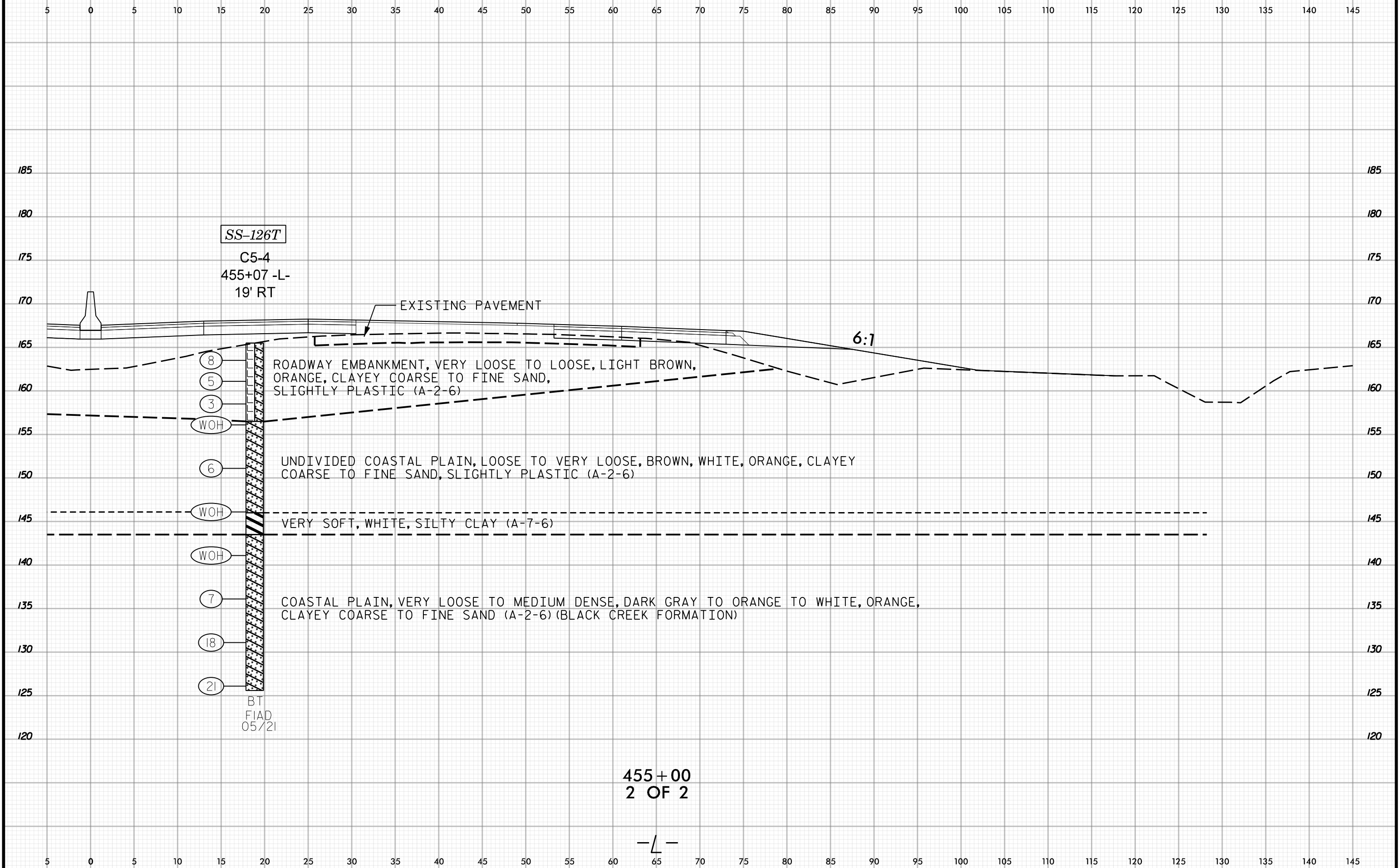

SS-126T

C5-4  
455+07 -L-  
19' RT

EXISTING PAVEMENT

6:1

8

5

3

WOH

6

WOH

WOH

7

18

21

BT  
FIAD  
05/21

ROADWAY EMBANKMENT, VERY LOOSE TO LOOSE, LIGHT BROWN, ORANGE, CLAYEY COARSE TO FINE SAND, SLIGHTLY PLASTIC (A-2-6)

UNDIVIDED COASTAL PLAIN, LOOSE TO VERY LOOSE, BROWN, WHITE, ORANGE, CLAYEY COARSE TO FINE SAND, SLIGHTLY PLASTIC (A-2-6)

VERY SOFT, WHITE, SILTY CLAY (A-7-6)

COASTAL PLAIN, VERY LOOSE TO MEDIUM DENSE, DARK GRAY TO ORANGE TO WHITE, ORANGE, CLAYEY COARSE TO FINE SAND (A-2-6) (BLACK CREEK FORMATION)

455+00  
2 OF 2

-L-

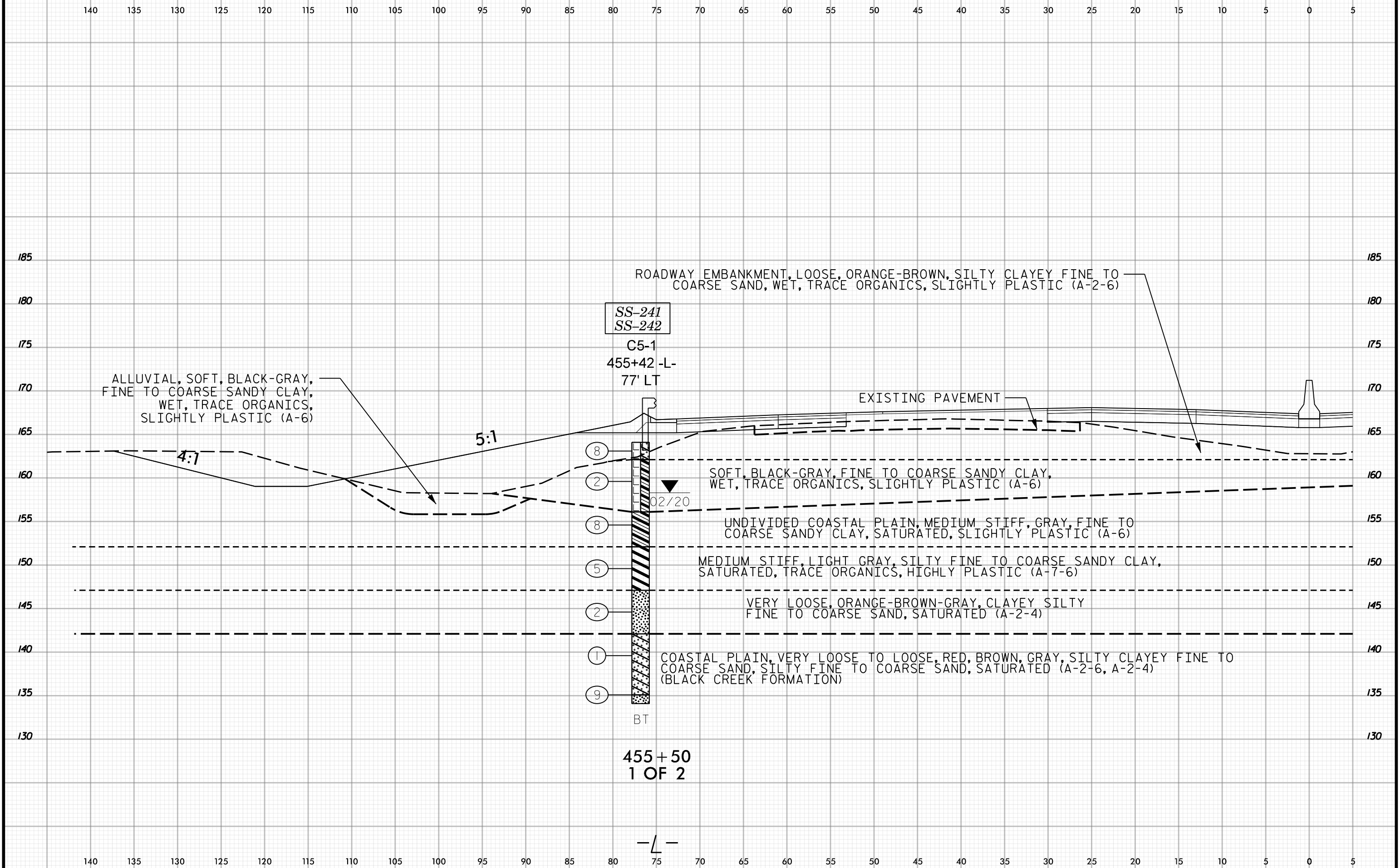

SS-241  
SS-242

C5-1  
455+42 -L-  
77' LT

ALLUVIAL, SOFT, BLACK-GRAY,  
FINE TO COARSE SANDY CLAY,  
WET, TRACE ORGANICS,  
SLIGHTLY PLASTIC (A-6)

ROADWAY EMBANKMENT, LOOSE, ORANGE-BROWN, SILTY CLAYEY FINE TO  
COARSE SAND, WET, TRACE ORGANICS, SLIGHTLY PLASTIC (A-2-6)

EXISTING PAVEMENT

SOFT, BLACK-GRAY, FINE TO COARSE SANDY CLAY,  
WET, TRACE ORGANICS, SLIGHTLY PLASTIC (A-6)

UNDIVIDED COASTAL PLAIN, MEDIUM STIFF, GRAY, FINE TO  
COARSE SANDY CLAY, SATURATED, SLIGHTLY PLASTIC (A-6)

MEDIUM STIFF, LIGHT GRAY, SILTY FINE TO COARSE SANDY CLAY,  
SATURATED, TRACE ORGANICS, HIGHLY PLASTIC (A-7-6)

VERY LOOSE, ORANGE-BROWN-GRAY, CLAYEY SILTY  
FINE TO COARSE SAND, SATURATED (A-2-4)

COASTAL PLAIN, VERY LOOSE TO LOOSE, RED, BROWN, GRAY, SILTY CLAYEY FINE TO  
COARSE SAND, SILTY FINE TO COARSE SAND, SATURATED (A-2-6, A-2-4)  
(BLACK CREEK FORMATION)

BT

455 + 50  
1 OF 2

-L-

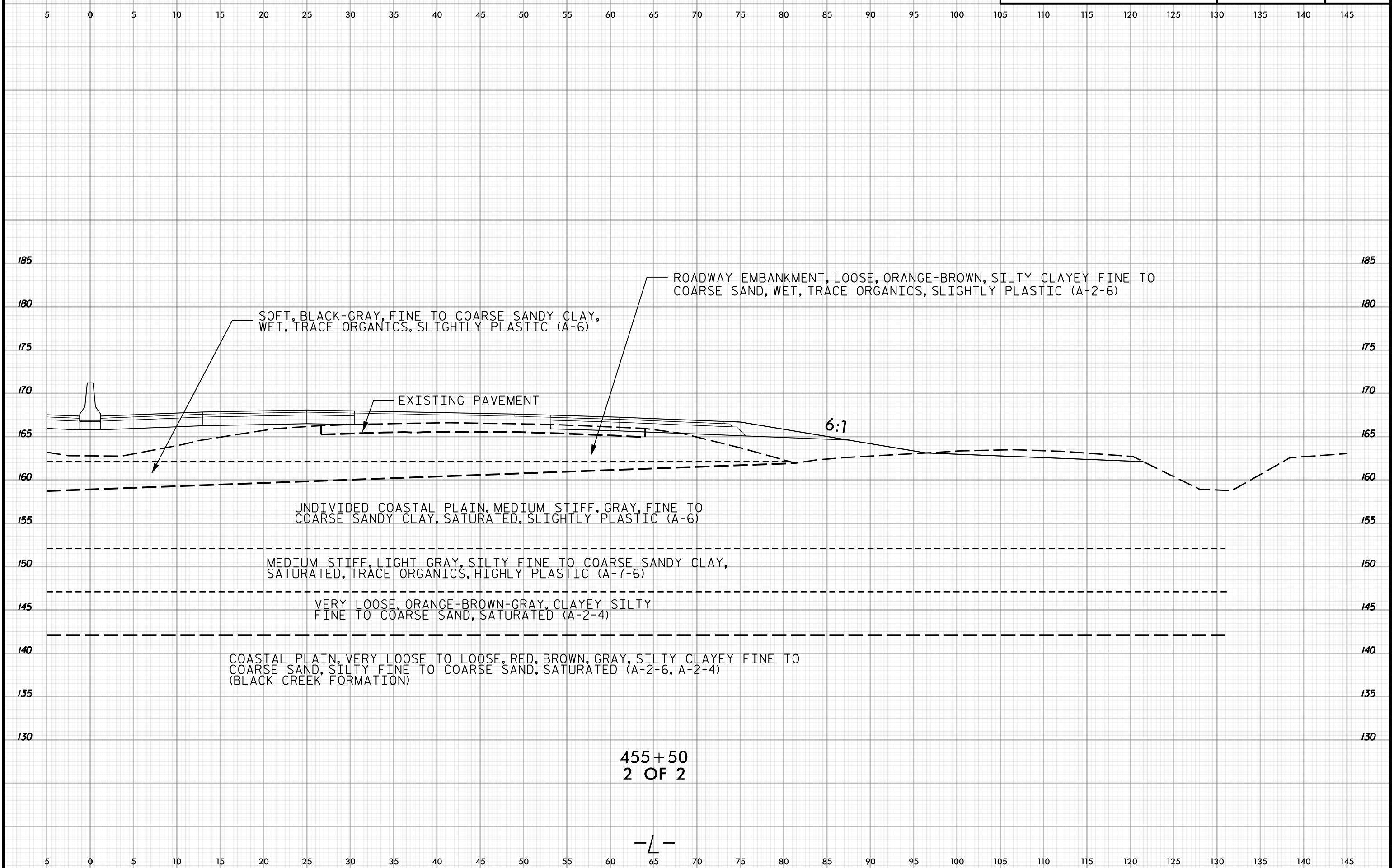

455 + 50  
2 OF 2

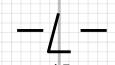





140 135 130 125 120 115 110 105 100 95 90 85 80 75 70 65 60 55 50 45 40 35 30 25 20 15 10 5 0 5

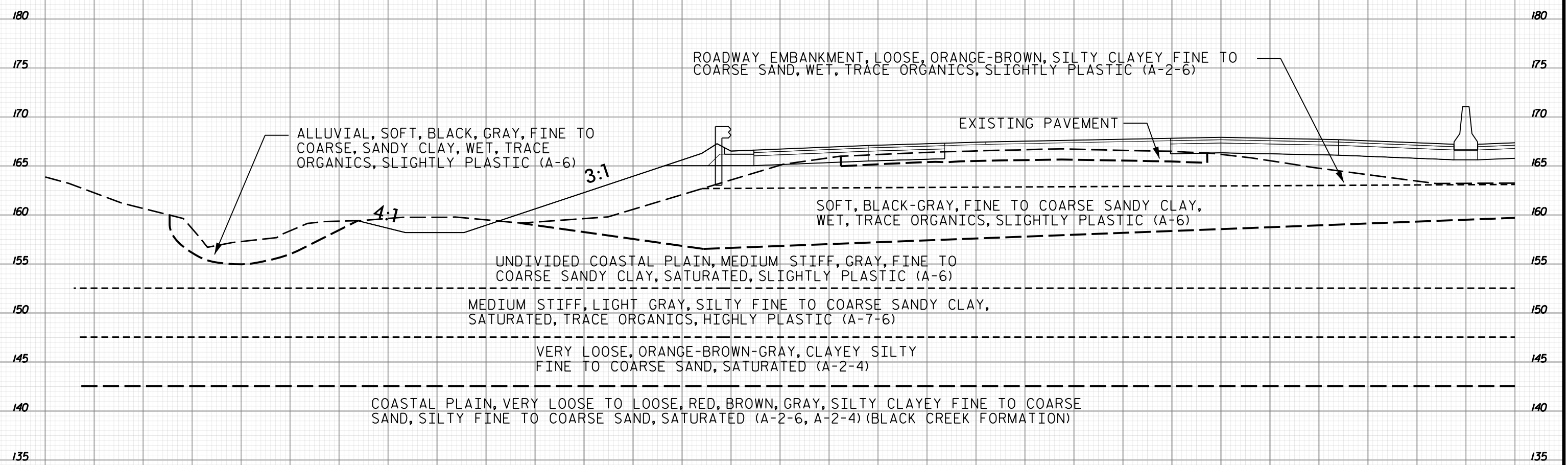

456+00  
1 OF 2

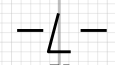

140 135 130 125 120 115 110 105 100 95 90 85 80 75 70 65 60 55 50 45 40 35 30 25 20 15 10 5 0 5



5 0 5 10 15 20 25 30 35 40 45 50 55 60 65 70 75 80 85 90 95 100 105 110 115 120 125 130 135 140 145

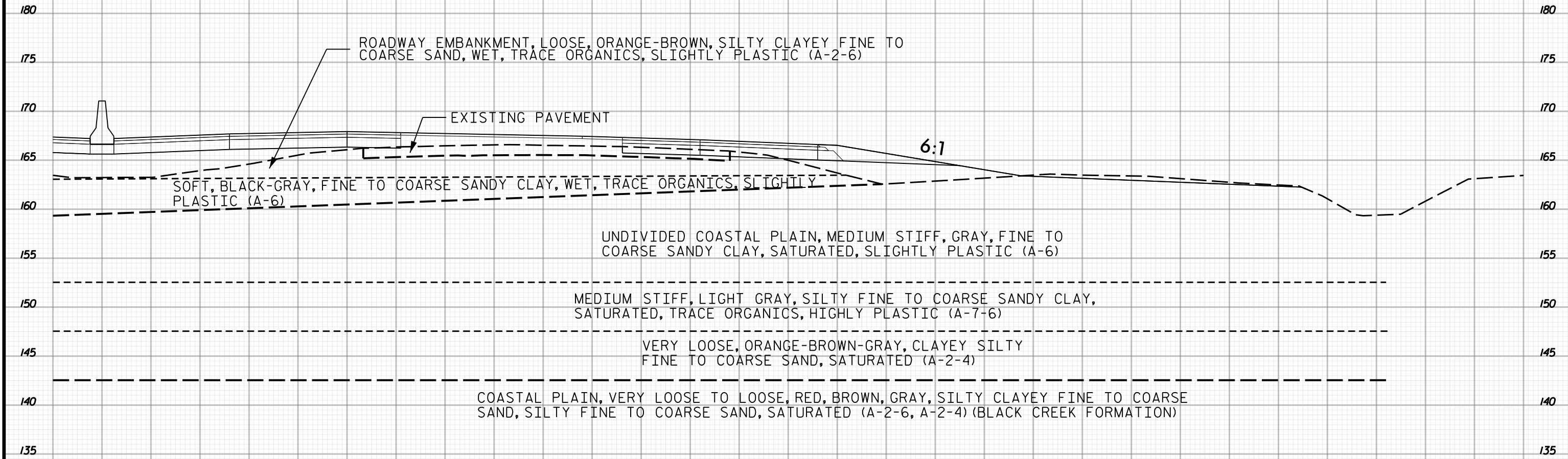

ROADWAY EMBANKMENT, LOOSE, ORANGE-BROWN, SILTY CLAYEY FINE TO COARSE SAND, WET, TRACE ORGANICS, SLIGHTLY PLASTIC (A-2-6)

EXISTING PAVEMENT

6:1

SOFT, BLACK-GRAY, FINE TO COARSE SANDY CLAY, WET, TRACE ORGANICS, SLIGHTLY PLASTIC (A-6)

UNDIVIDED COASTAL PLAIN, MEDIUM STIFF, GRAY, FINE TO COARSE SANDY CLAY, SATURATED, SLIGHTLY PLASTIC (A-6)

MEDIUM STIFF, LIGHT GRAY, SILTY FINE TO COARSE SANDY CLAY, SATURATED, TRACE ORGANICS, HIGHLY PLASTIC (A-7-6)

VERY LOOSE, ORANGE-BROWN-GRAY, CLAYEY SILTY FINE TO COARSE SAND, SATURATED (A-2-4)

COASTAL PLAIN, VERY LOOSE TO LOOSE, RED, BROWN, GRAY, SILTY CLAYEY FINE TO COARSE SAND, SILTY FINE TO COARSE SAND, SATURATED (A-2-6, A-2-4) (BLACK CREEK FORMATION)

456+00  
2 OF 2

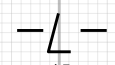

5 0 5 10 15 20 25 30 35 40 45 50 55 60 65 70 75 80 85 90 95 100 105 110 115 120 125 130 135 140 145



140 135 130 125 120 115 110 105 100 95 90 85 80 75 70 65 60 55 50 45 40 35 30 25 20 15 10 5 0 5

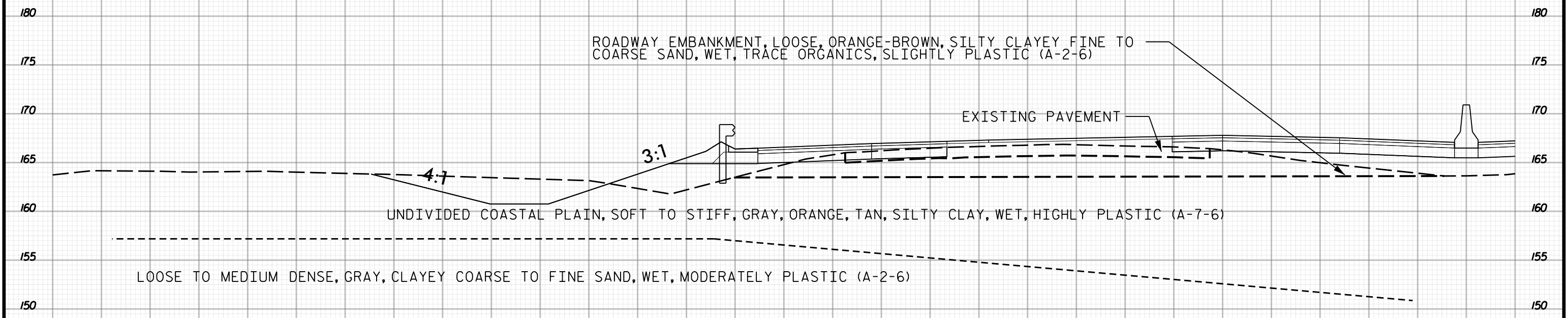

457+00

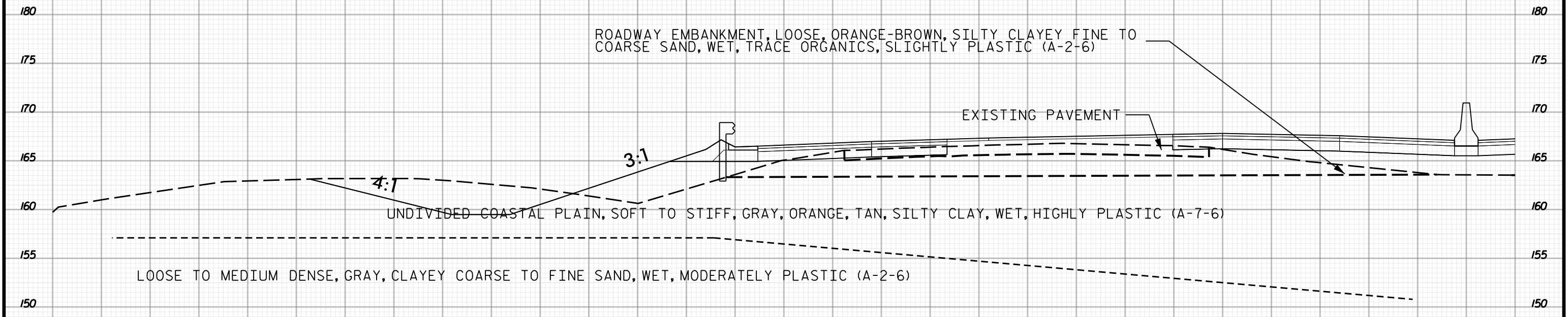

456+50  
1 OF 2

140 135 130 125 120 115 110 105 100 95 90 85 80 75 70 65 60 55 50 45 40 35 30 25 20 15 10 5 0 5

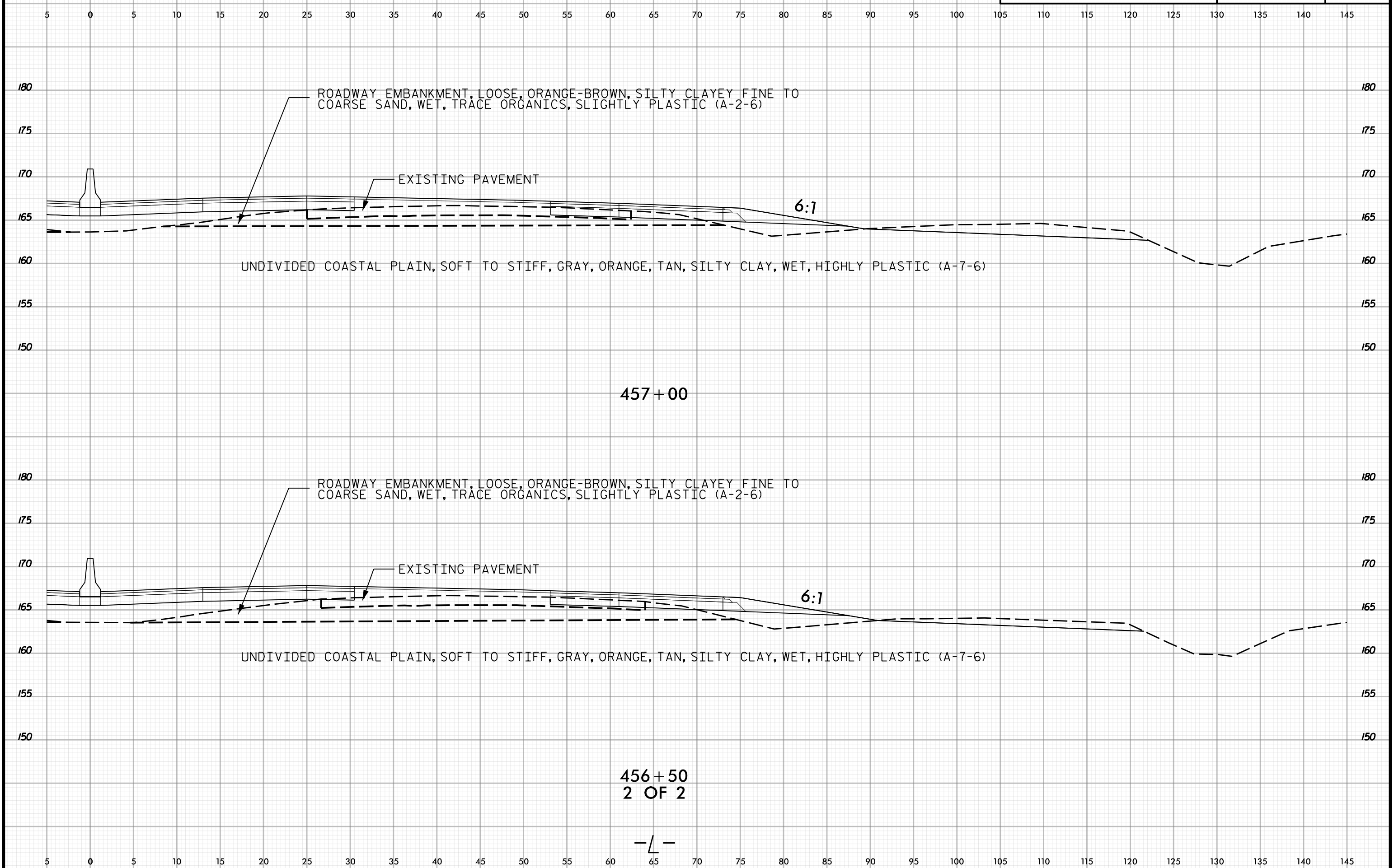

457+00

456+50  
2 OF 2

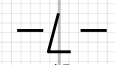



140 135 130 125 120 115 110 105 100 95 90 85 80 75 70 65 60 55 50 45 40 35 30 25 20 15 10 5 0 5

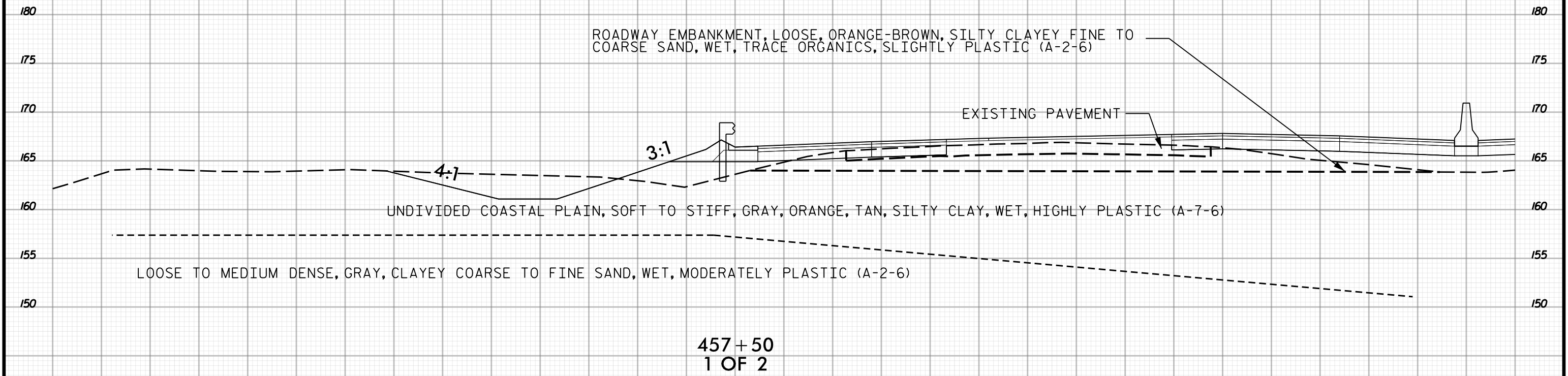
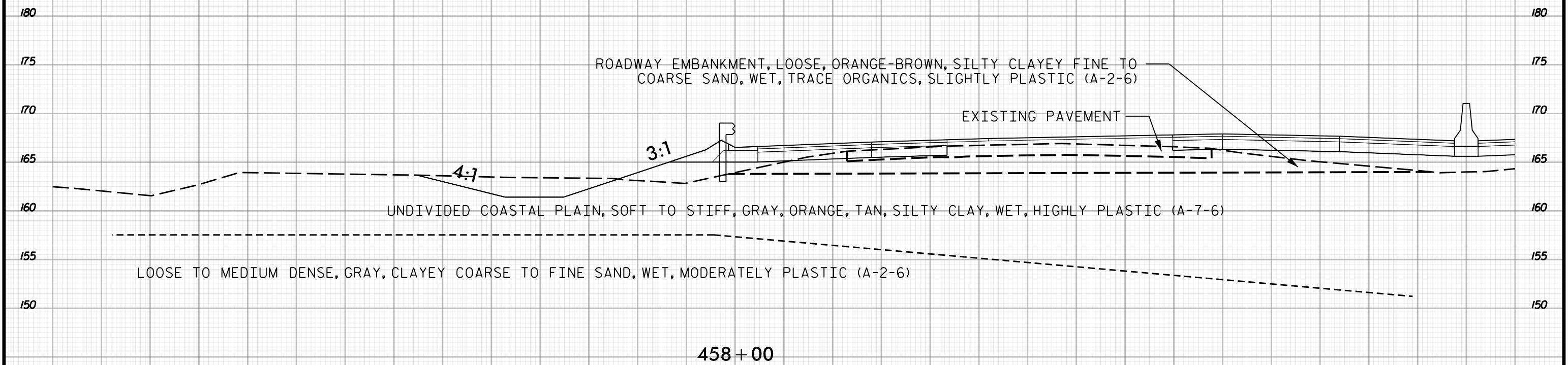

140 135 130 125 120 115 110 105 100 95 90 85 80 75 70 65 60 55 50 45 40 35 30 25 20 15 10 5 0 5

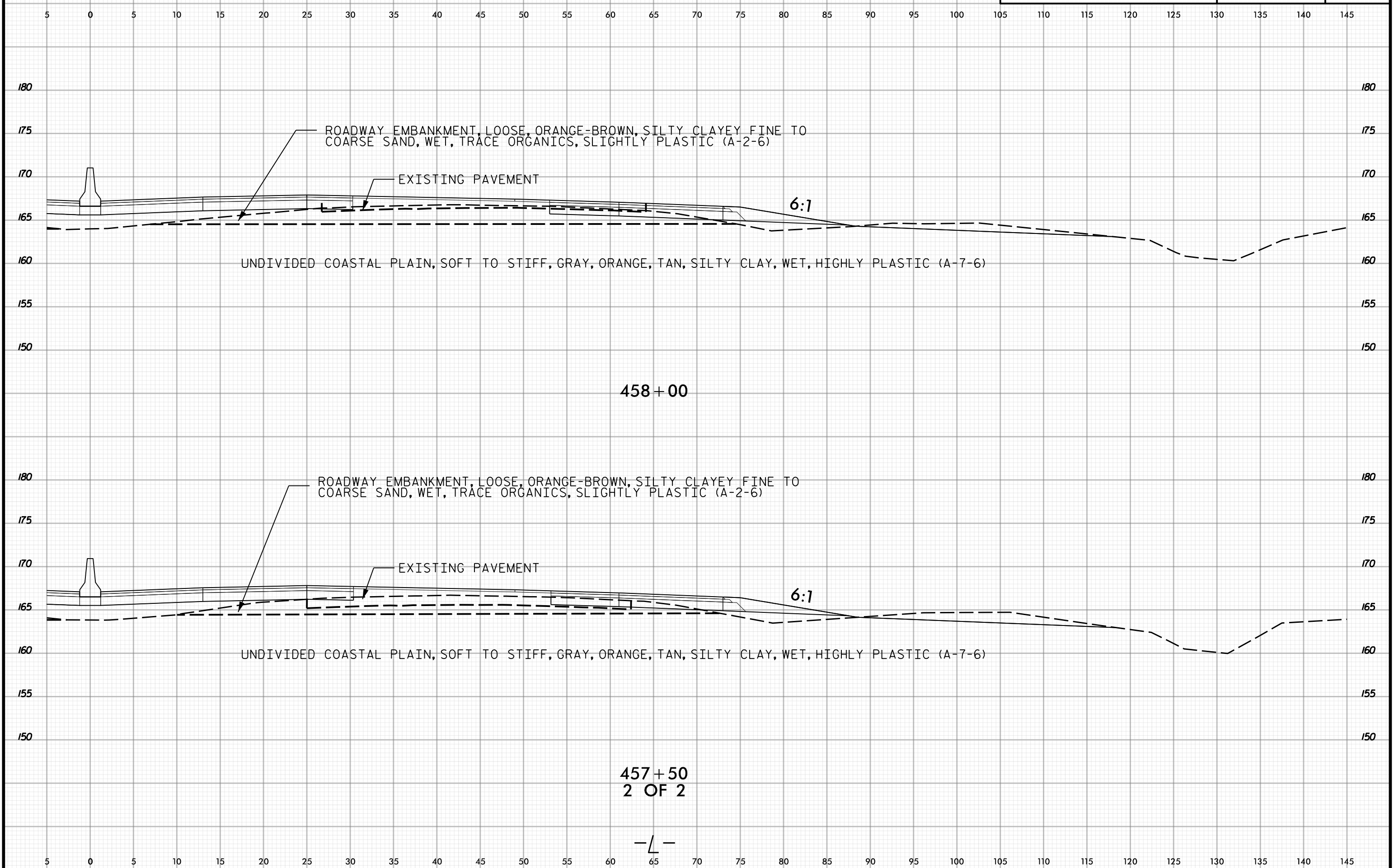

ROADWAY EMBANKMENT, LOOSE, ORANGE-BROWN, SILTY CLAYEY FINE TO COARSE SAND, WET, TRACE ORGANICS, SLIGHTLY PLASTIC (A-2-6)

EXISTING PAVEMENT

6:1

UNDIVIDED COASTAL PLAIN, SOFT TO STIFF, GRAY, ORANGE, TAN, SILTY CLAY, WET, HIGHLY PLASTIC (A-7-6)

458+00

ROADWAY EMBANKMENT, LOOSE, ORANGE-BROWN, SILTY CLAYEY FINE TO COARSE SAND, WET, TRACE ORGANICS, SLIGHTLY PLASTIC (A-2-6)

EXISTING PAVEMENT

6:1

UNDIVIDED COASTAL PLAIN, SOFT TO STIFF, GRAY, ORANGE, TAN, SILTY CLAY, WET, HIGHLY PLASTIC (A-7-6)

457+50  
2 OF 2

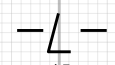



140 135 130 125 120 115 110 105 100 95 90 85 80 75 70 65 60 55 50 45 40 35 30 25 20 15 10 5 0 5

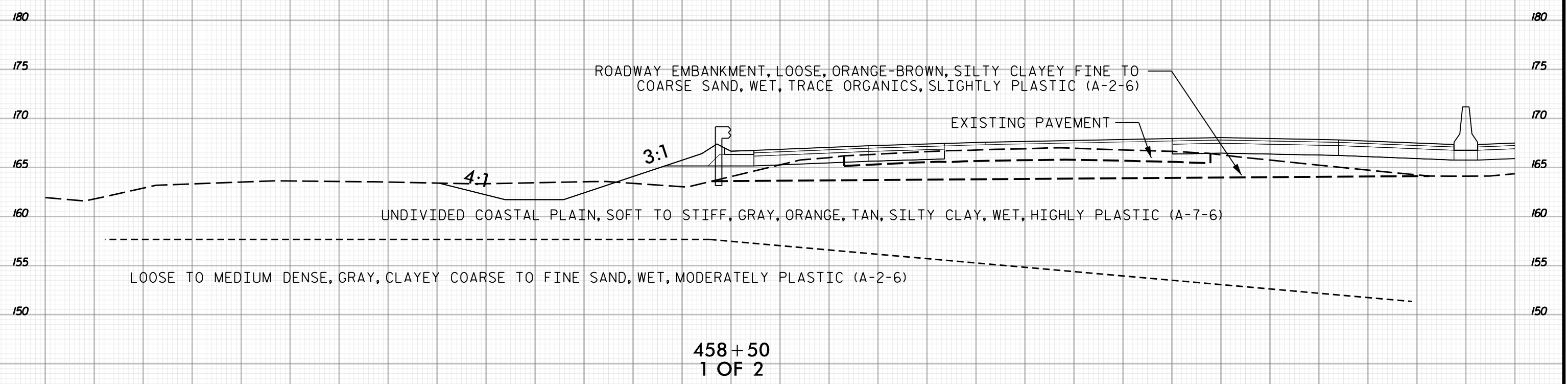
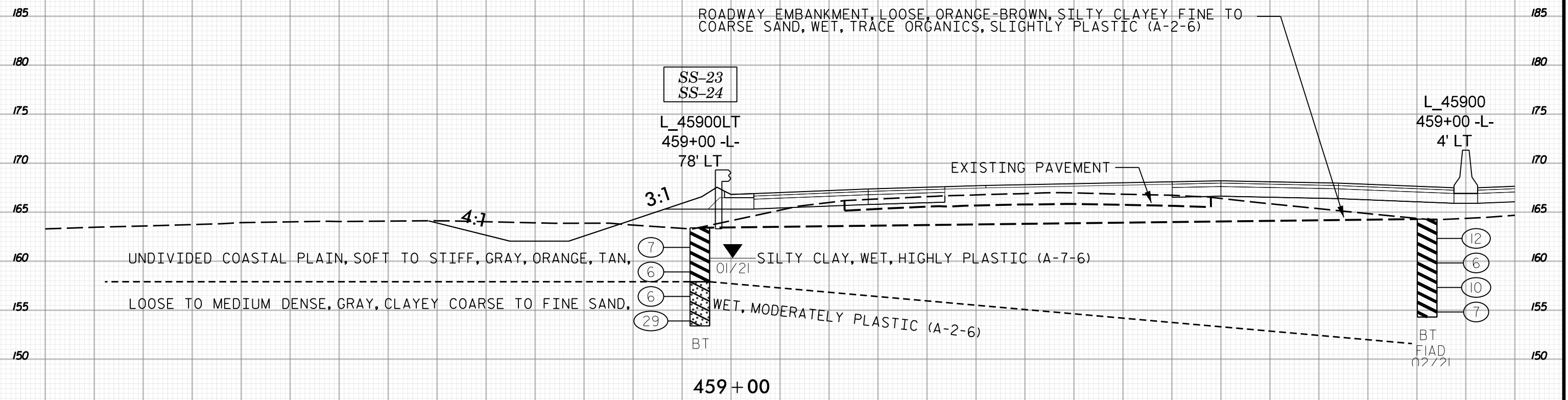

458+50  
1 OF 2

140 135 130 125 120 115 110 105 100 95 90 85 80 75 70 65 60 55 50 45 40 35 30 25 20 15 10 5 0 5

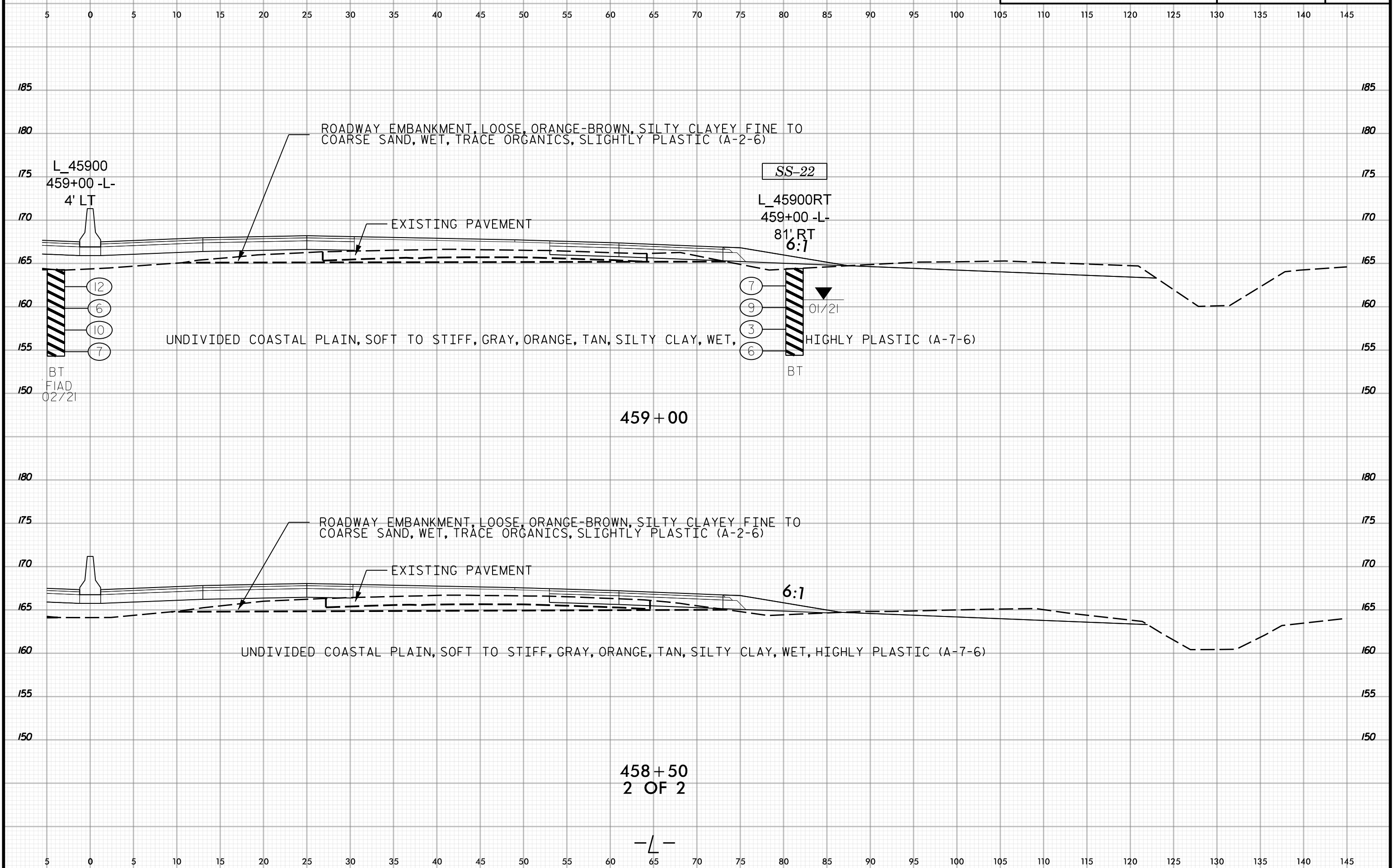





140 135 130 125 120 115 110 105 100 95 90 85 80 75 70 65 60 55 50 45 40 35 30 25 20 15 10 5 0 5

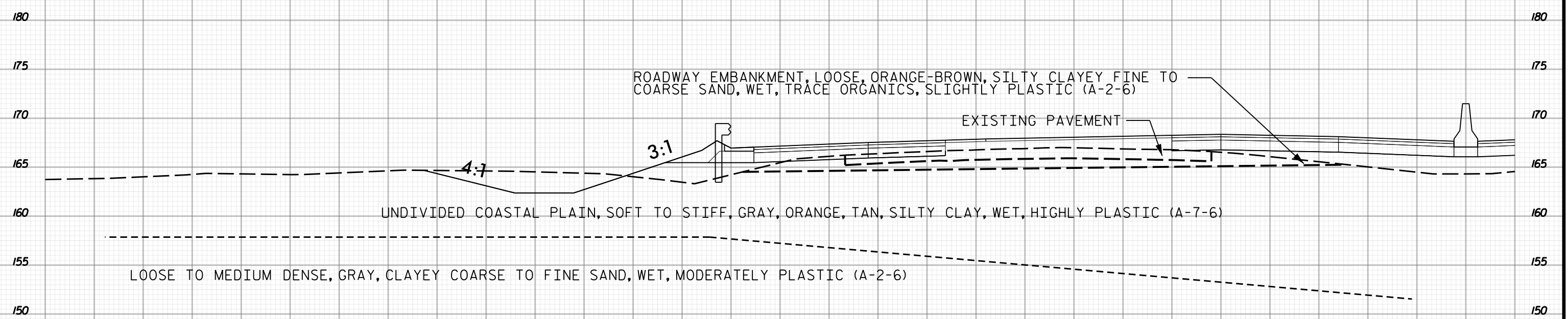
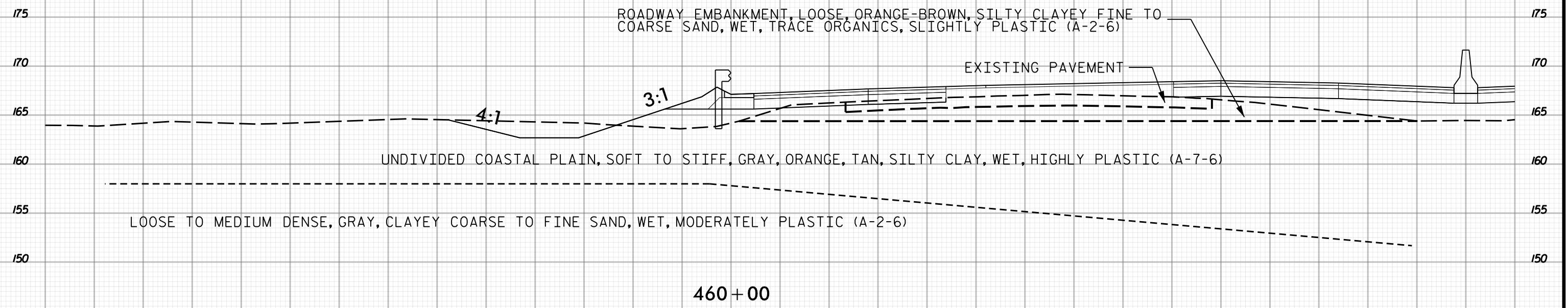

1 OF 2

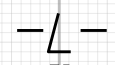

140 135 130 125 120 115 110 105 100 95 90 85 80 75 70 65 60 55 50 45 40 35 30 25 20 15 10 5 0 5



PROJ. REFERENCE NO.	SHEET NO.
I-5987A	839

5 0 5 10 15 20 25 30 35 40 45 50 55 60 65 70 75 80 85 90 95 100 105 110 115 120 125 130 135 140 145

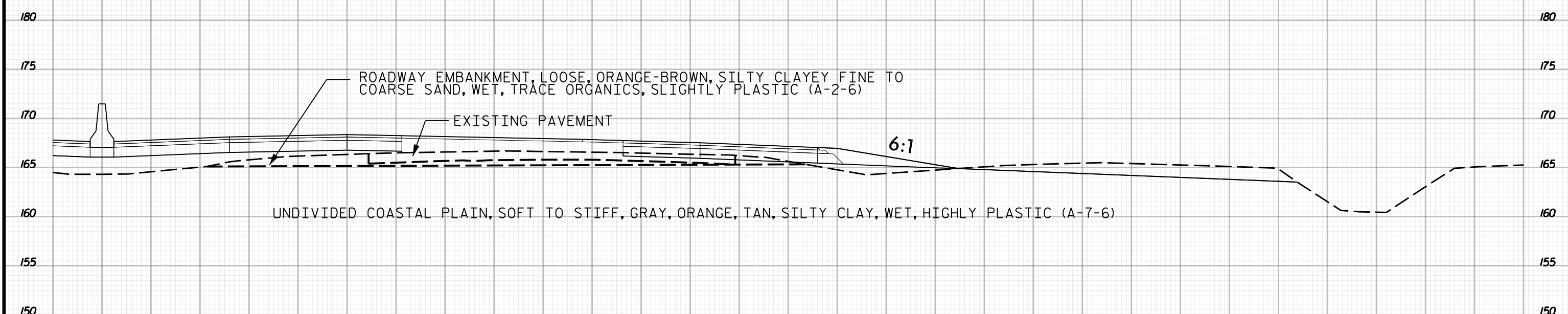
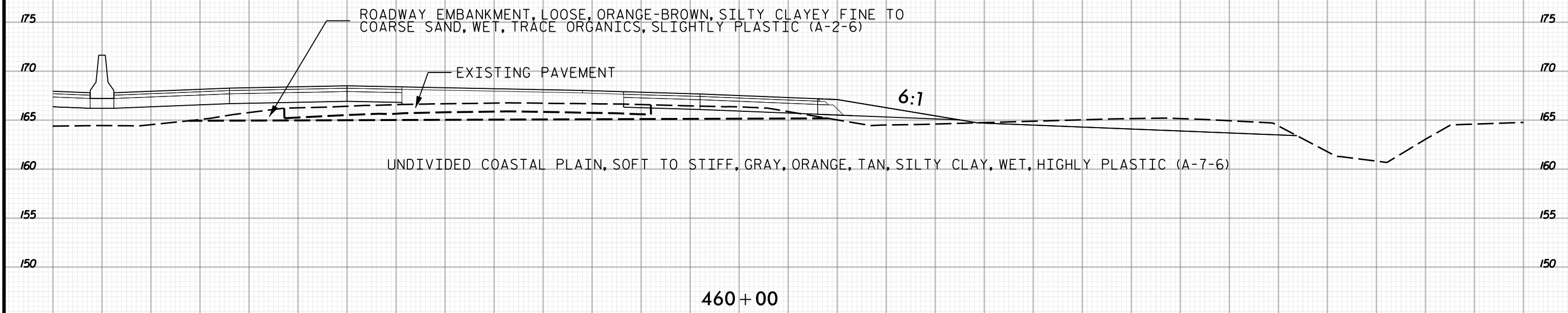

2 OF 2

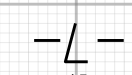

5 0 5 10 15 20 25 30 35 40 45 50 55 60 65 70 75 80 85 90 95 100 105 110 115 120 125 130 135 140 145



140 135 130 125 120 115 110 105 100 95 90 85 80 75 70 65 60 55 50 45 40 35 30 25 20 15 10 5 0 5

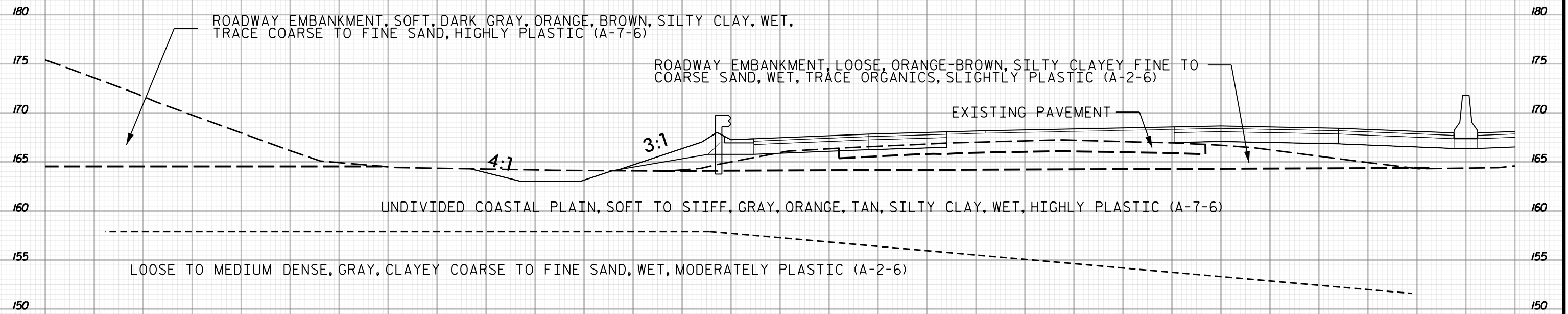

460 + 50  
1 OF 2

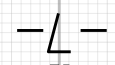

140 135 130 125 120 115 110 105 100 95 90 85 80 75 70 65 60 55 50 45 40 35 30 25 20 15 10 5 0 5



PROJ. REFERENCE NO.	SHEET NO.
I-5987A	841

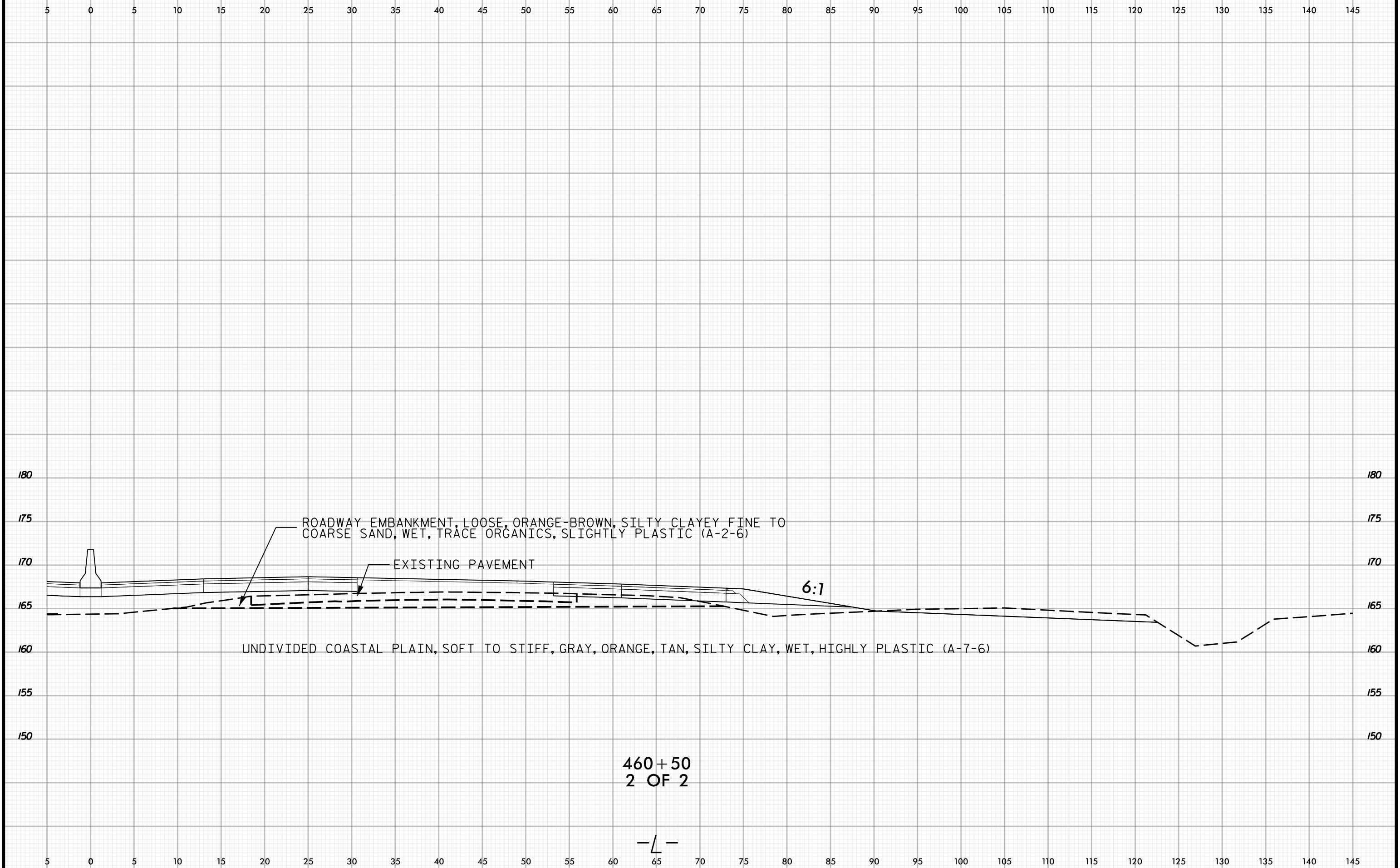

ROADWAY EMBANKMENT, LOOSE, ORANGE-BROWN, SILTY CLAYEY FINE TO COARSE SAND, WET, TRACE ORGANICS, SLIGHTLY PLASTIC (A-2-6)

EXISTING PAVEMENT

6:1

UNDIVIDED COASTAL PLAIN, SOFT TO STIFF, GRAY, ORANGE, TAN, SILTY CLAY, WET, HIGHLY PLASTIC (A-7-6)

460+50  
2 OF 2

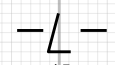

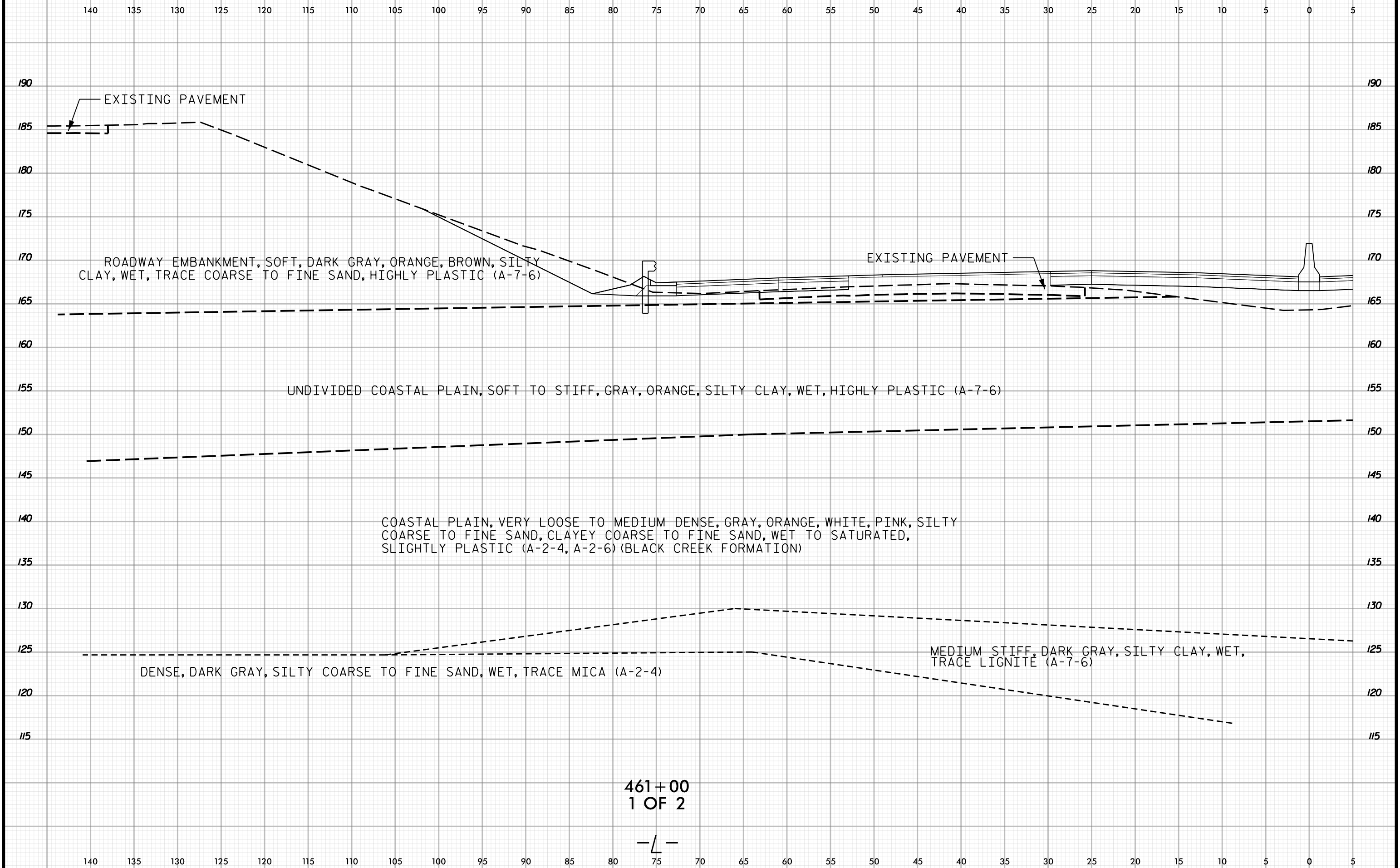

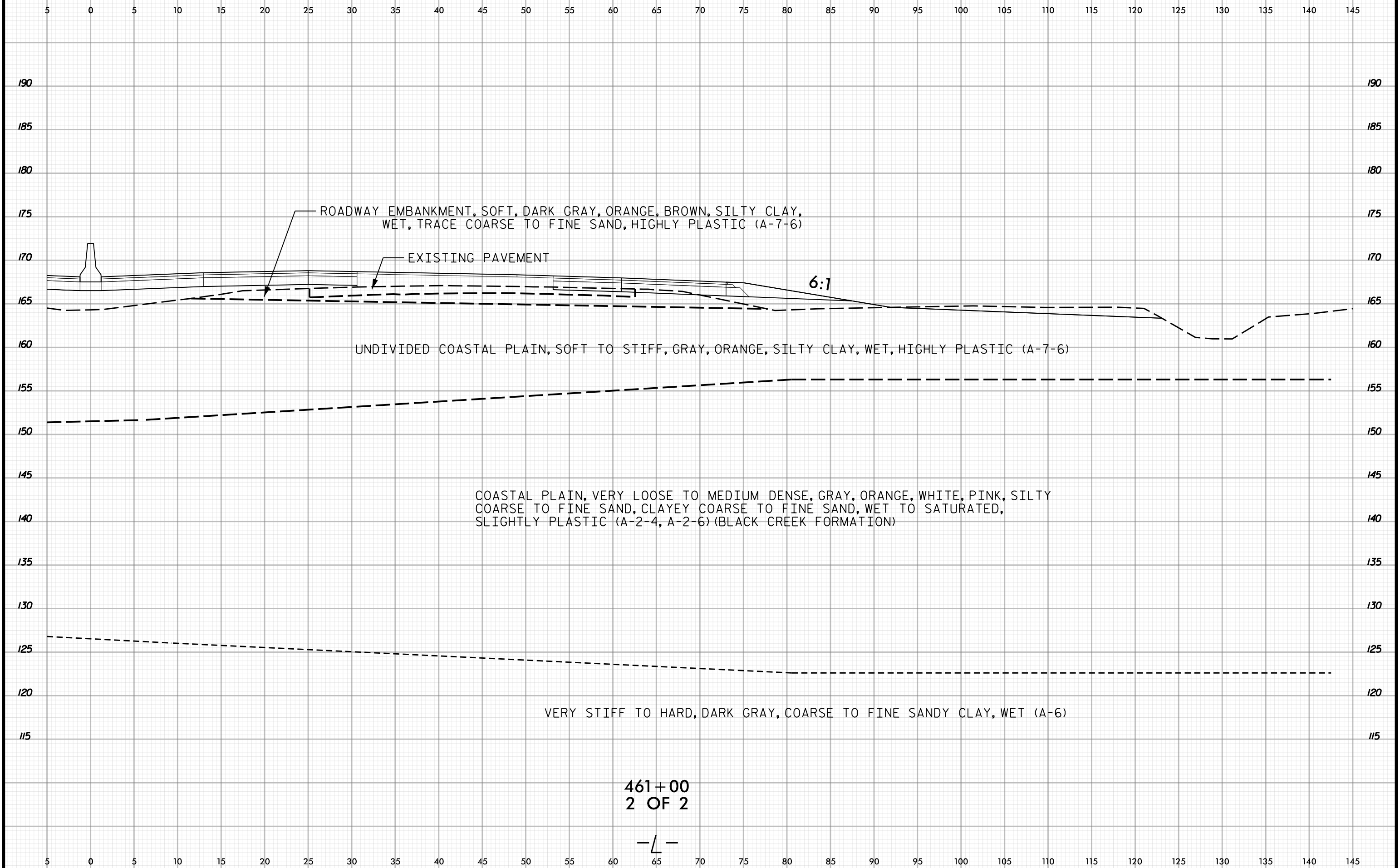
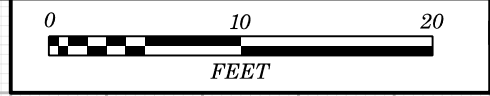

ROADWAY EMBANKMENT, SOFT, DARK GRAY, ORANGE, BROWN, SILTY CLAY, WET, TRACE COARSE TO FINE SAND, HIGHLY PLASTIC (A-7-6)

EXISTING PAVEMENT

6:1

UNDIVIDED COASTAL PLAIN, SOFT TO STIFF, GRAY, ORANGE, SILTY CLAY, WET, HIGHLY PLASTIC (A-7-6)

COASTAL PLAIN, VERY LOOSE TO MEDIUM DENSE, GRAY, ORANGE, WHITE, PINK, SILTY COARSE TO FINE SAND, CLAYEY COARSE TO FINE SAND, WET TO SATURATED, SLIGHTLY PLASTIC (A-2-4, A-2-6) (BLACK CREEK FORMATION)

VERY STIFF TO HARD, DARK GRAY, COARSE TO FINE SANDY CLAY, WET (A-6)

461+00  
2 OF 2

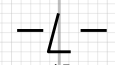

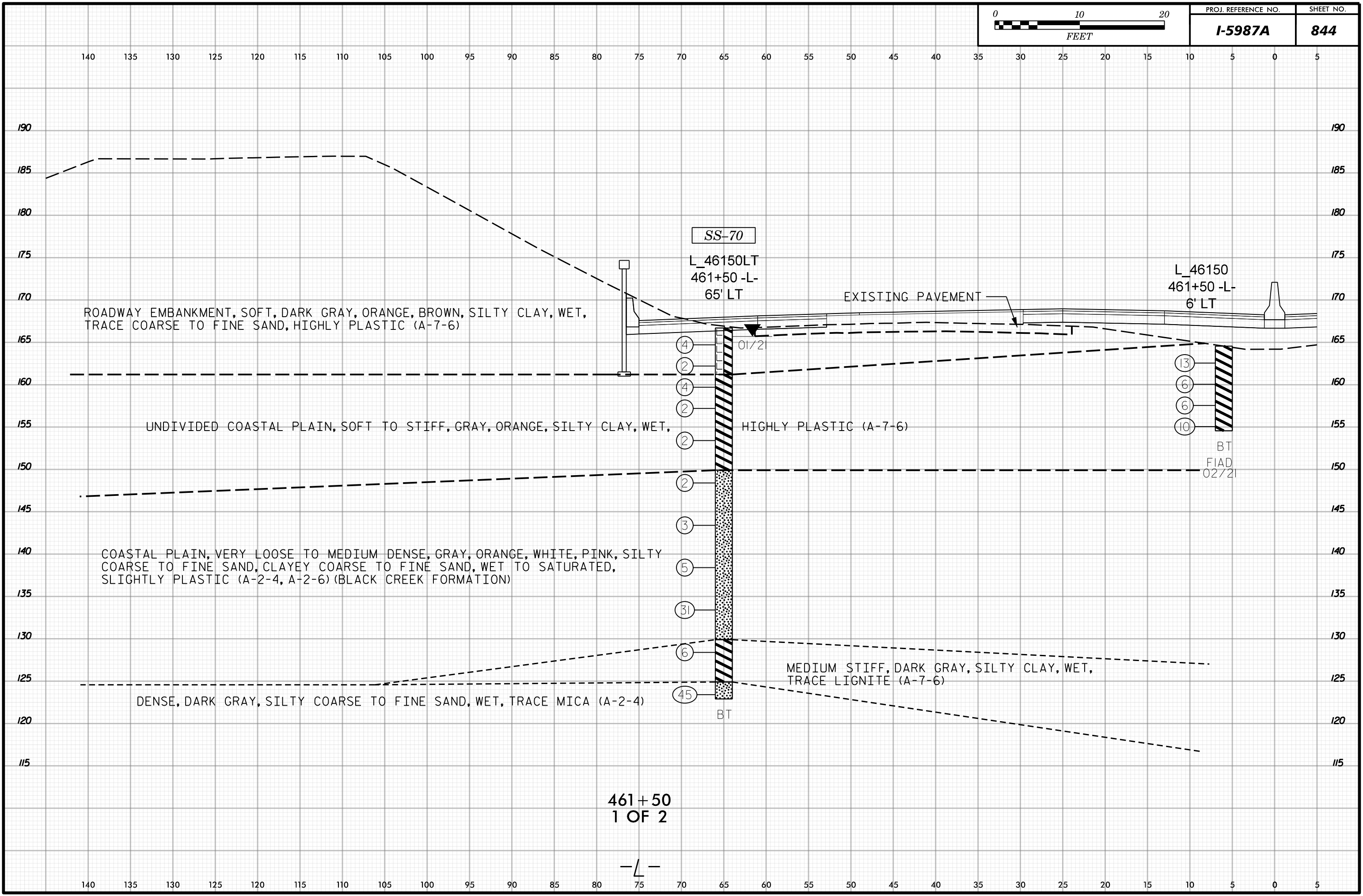
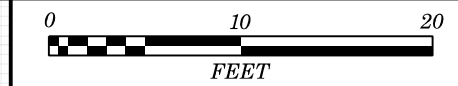

461+50  
1 OF 2

-L-

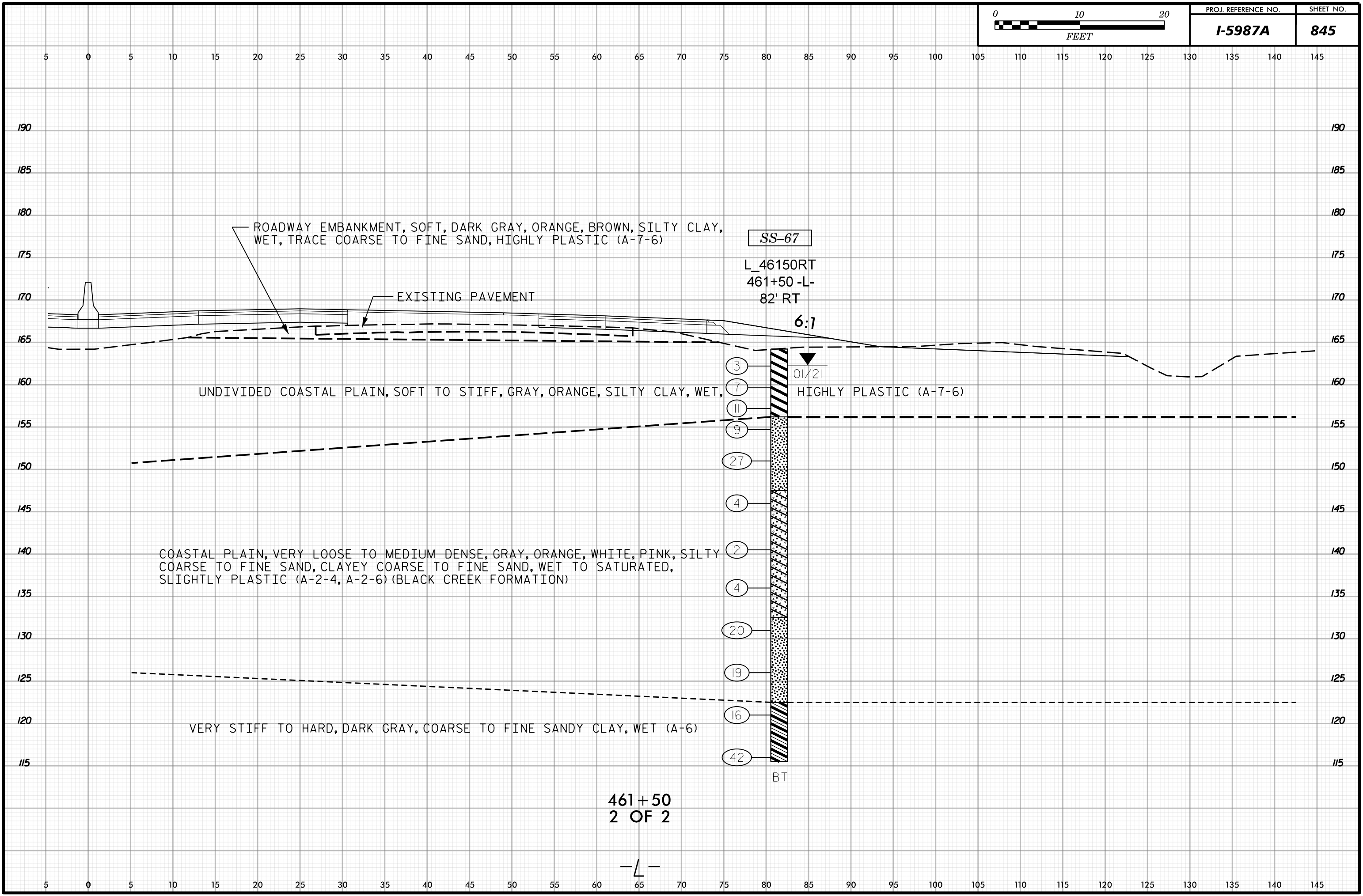

ROADWAY EMBANKMENT, SOFT, DARK GRAY, ORANGE, BROWN, SILTY CLAY, WET, TRACE COARSE TO FINE SAND, HIGHLY PLASTIC (A-7-6)

SS-67

L\_46150RT  
461+50 -L-  
82' RT

EXISTING PAVEMENT

6:1

UNDIVIDED COASTAL PLAIN, SOFT TO STIFF, GRAY, ORANGE, SILTY CLAY, WET,

01/21  
HIGHLY PLASTIC (A-7-6)

COASTAL PLAIN, VERY LOOSE TO MEDIUM DENSE, GRAY, ORANGE, WHITE, PINK, SILTY COARSE TO FINE SAND, CLAYEY COARSE TO FINE SAND, WET TO SATURATED, SLIGHTLY PLASTIC (A-2-4, A-2-6) (BLACK CREEK FORMATION)

VERY STIFF TO HARD, DARK GRAY, COARSE TO FINE SANDY CLAY, WET (A-6)

- 3
- 7
- 11
- 9
- 27
- 4
- 2
- 4
- 20
- 19
- 16
- 42

BT

461+50  
2 OF 2

-L-



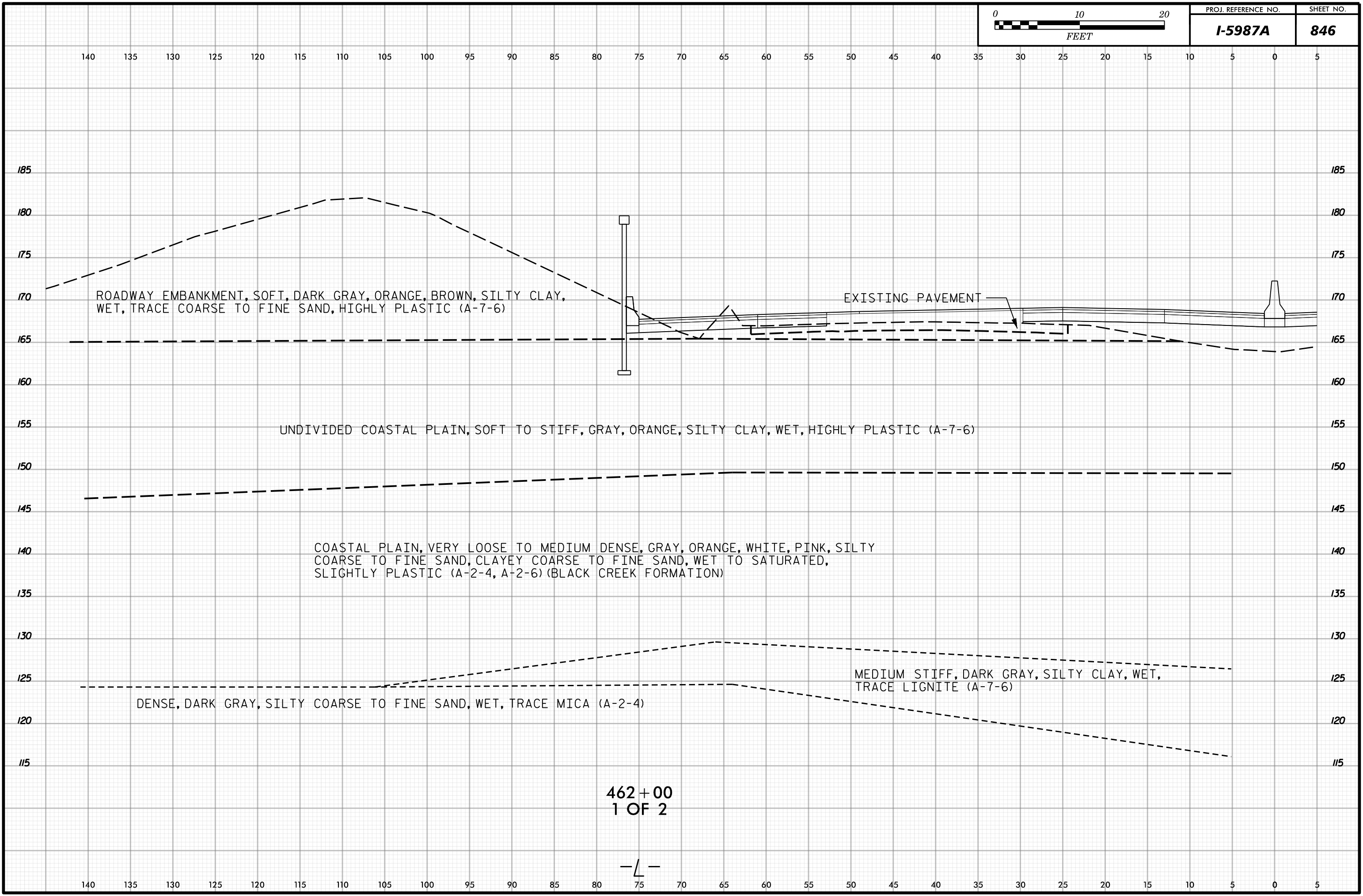

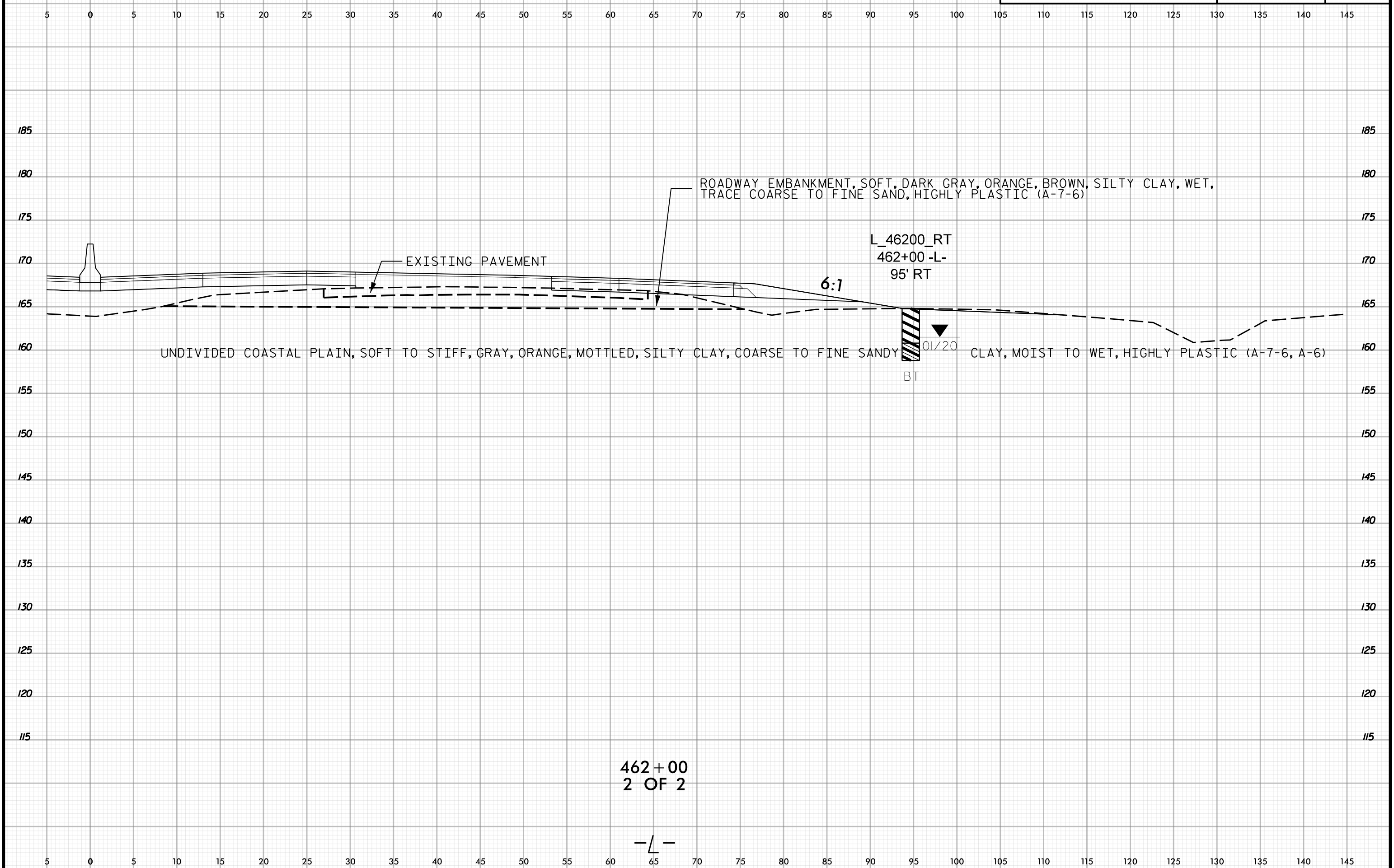

462+00  
2 OF 2

—L—

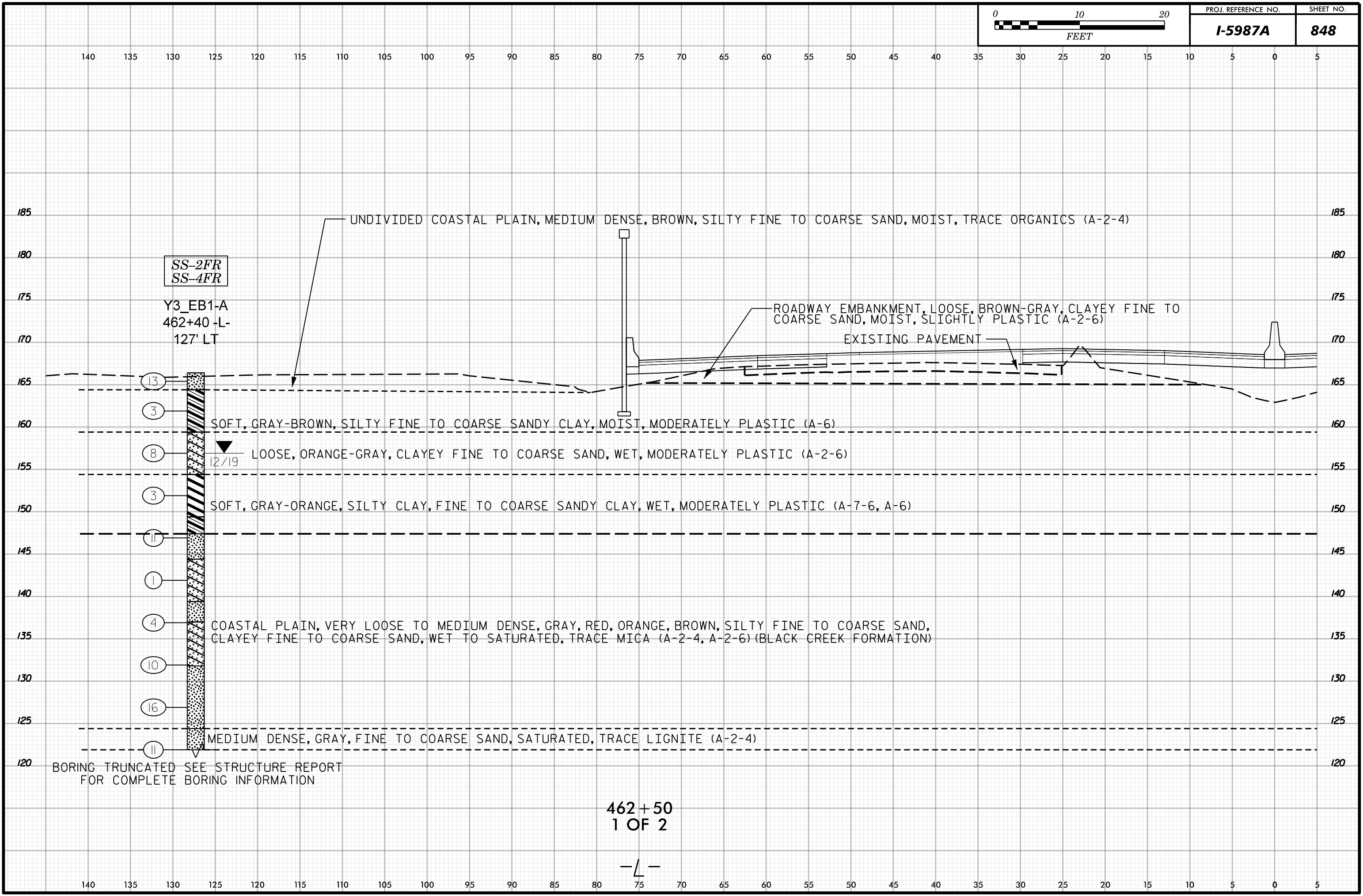

SS-2FR  
SS-4FR

Y3\_EB1-A  
462+40 -L-  
127' LT

- 13
- 3
- 8
- 3
- 11
- 1
- 4
- 10
- 16
- 11

UNDIVIDED COASTAL PLAIN, MEDIUM DENSE, BROWN, SILTY FINE TO COARSE SAND, MOIST, TRACE ORGANICS (A-2-4)

SOFT, GRAY-BROWN, SILTY FINE TO COARSE SANDY CLAY, MOIST, MODERATELY PLASTIC (A-6)

LOOSE, ORANGE-GRAY, CLAYEY FINE TO COARSE SAND, WET, MODERATELY PLASTIC (A-2-6)

SOFT, GRAY-ORANGE, SILTY CLAY, FINE TO COARSE SANDY CLAY, WET, MODERATELY PLASTIC (A-7-6, A-6)

COASTAL PLAIN, VERY LOOSE TO MEDIUM DENSE, GRAY, RED, ORANGE, BROWN, SILTY FINE TO COARSE SAND, CLAYEY FINE TO COARSE SAND, WET TO SATURATED, TRACE MICA (A-2-4, A-2-6) (BLACK CREEK FORMATION)

MEDIUM DENSE, GRAY, FINE TO COARSE SAND, SATURATED, TRACE LIGNITE (A-2-4)

ROADWAY EMBANKMENT, LOOSE, BROWN-GRAY, CLAYEY FINE TO COARSE SAND, MOIST, SLIGHTLY PLASTIC (A-2-6)

EXISTING PAVEMENT

BORING TRUNCATED SEE STRUCTURE REPORT FOR COMPLETE BORING INFORMATION

462 + 50  
1 OF 2

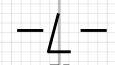

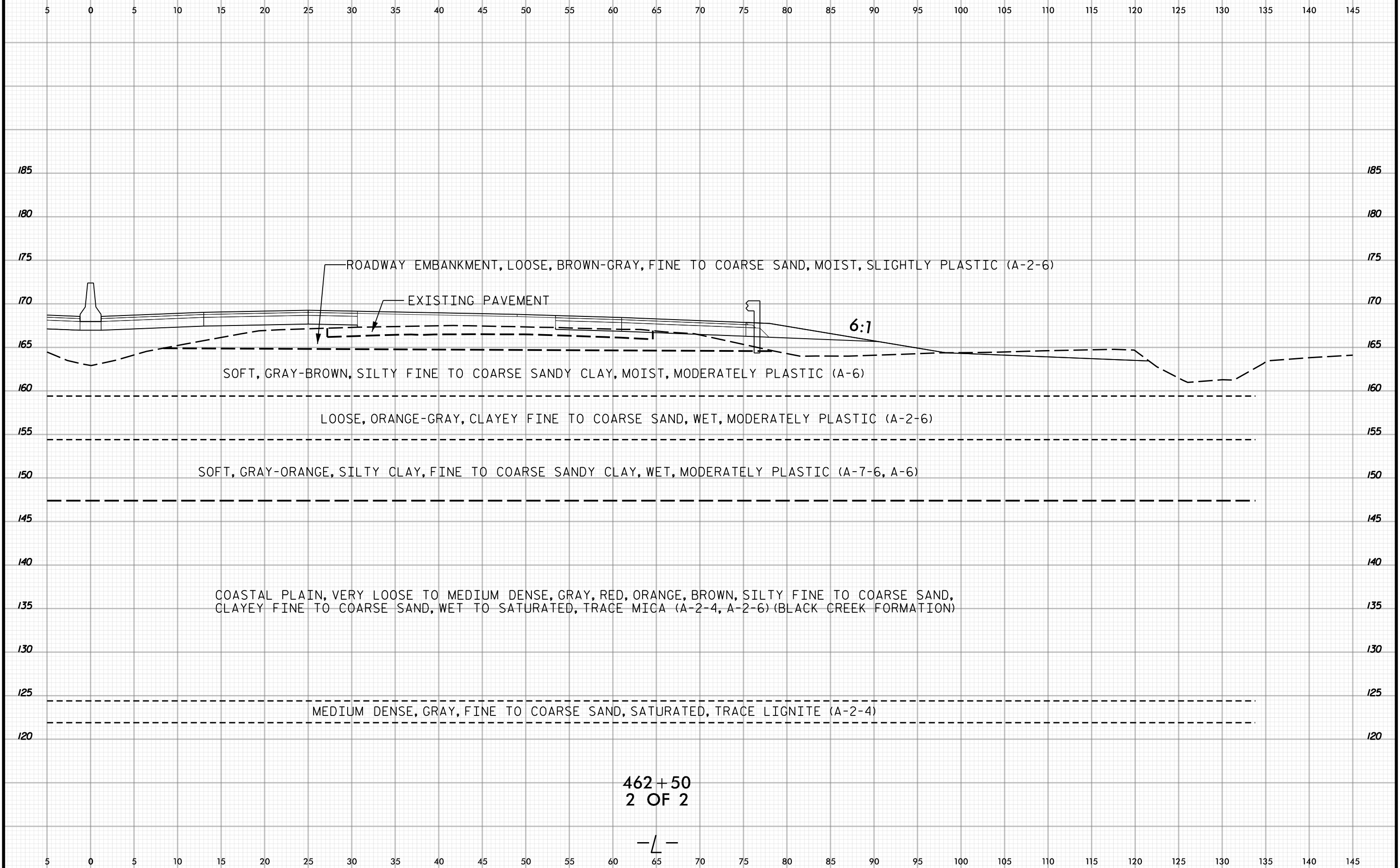

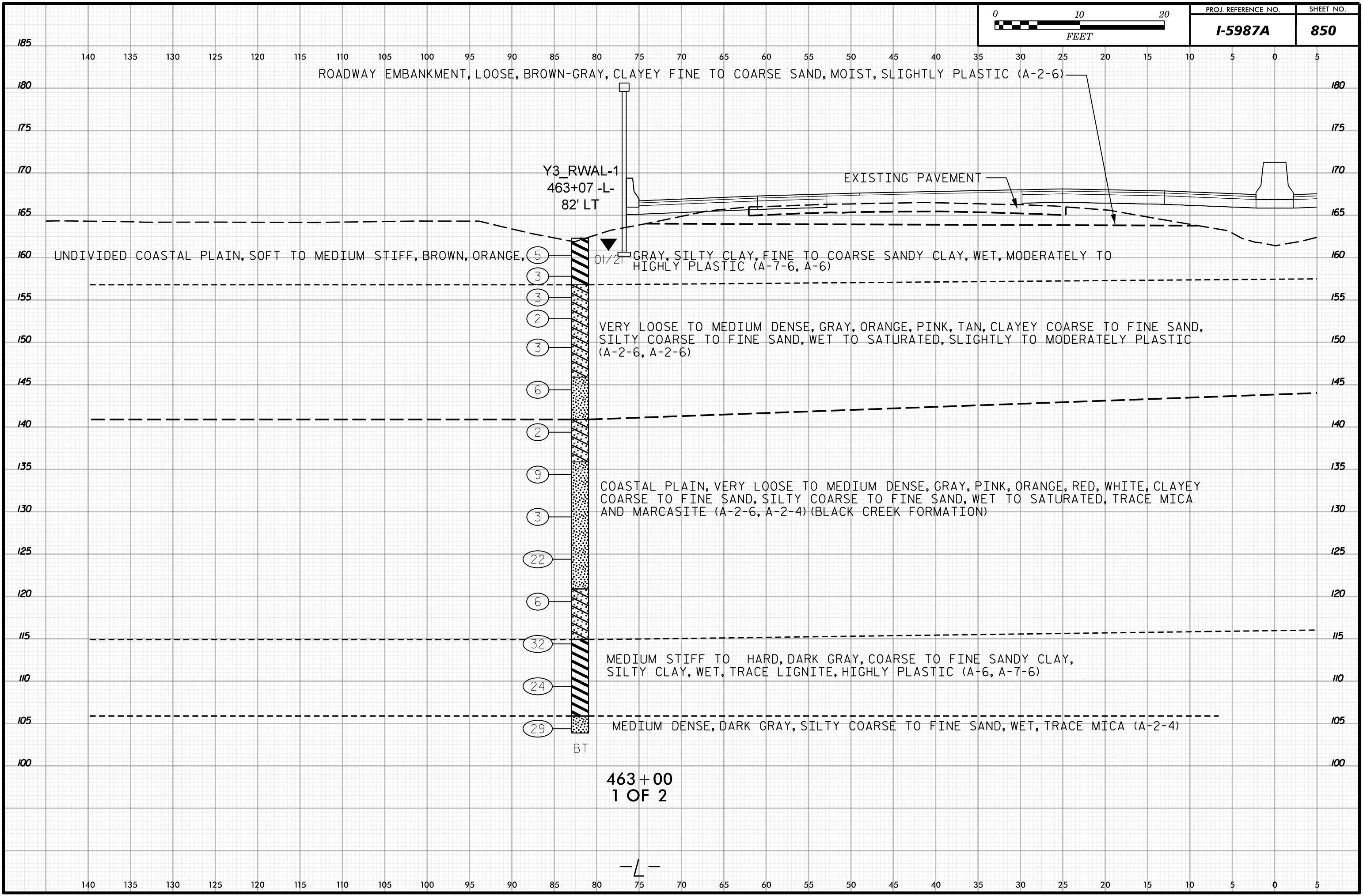
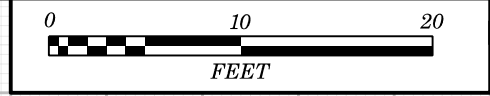

463+00  
1 OF 2

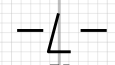

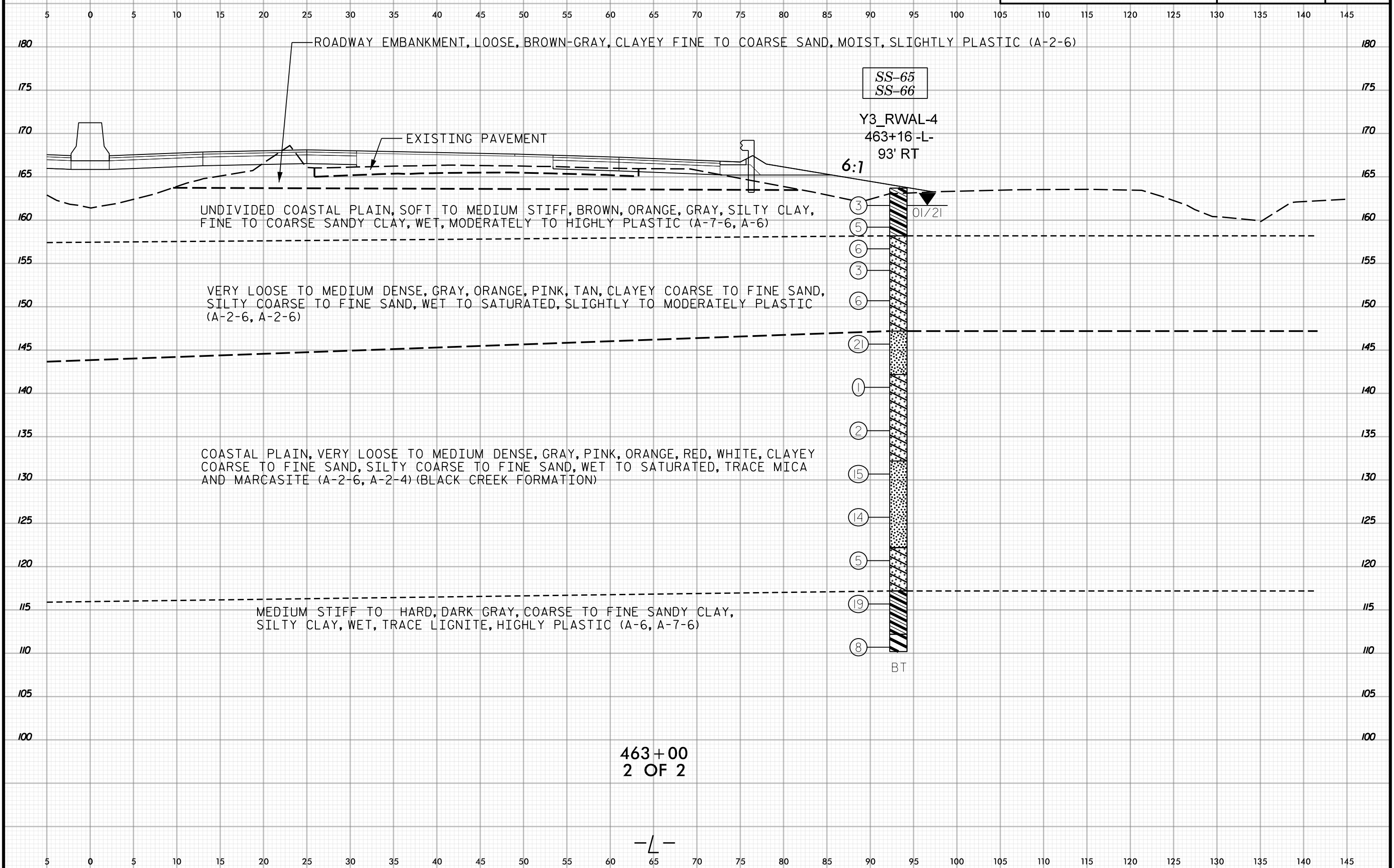
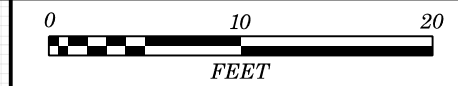

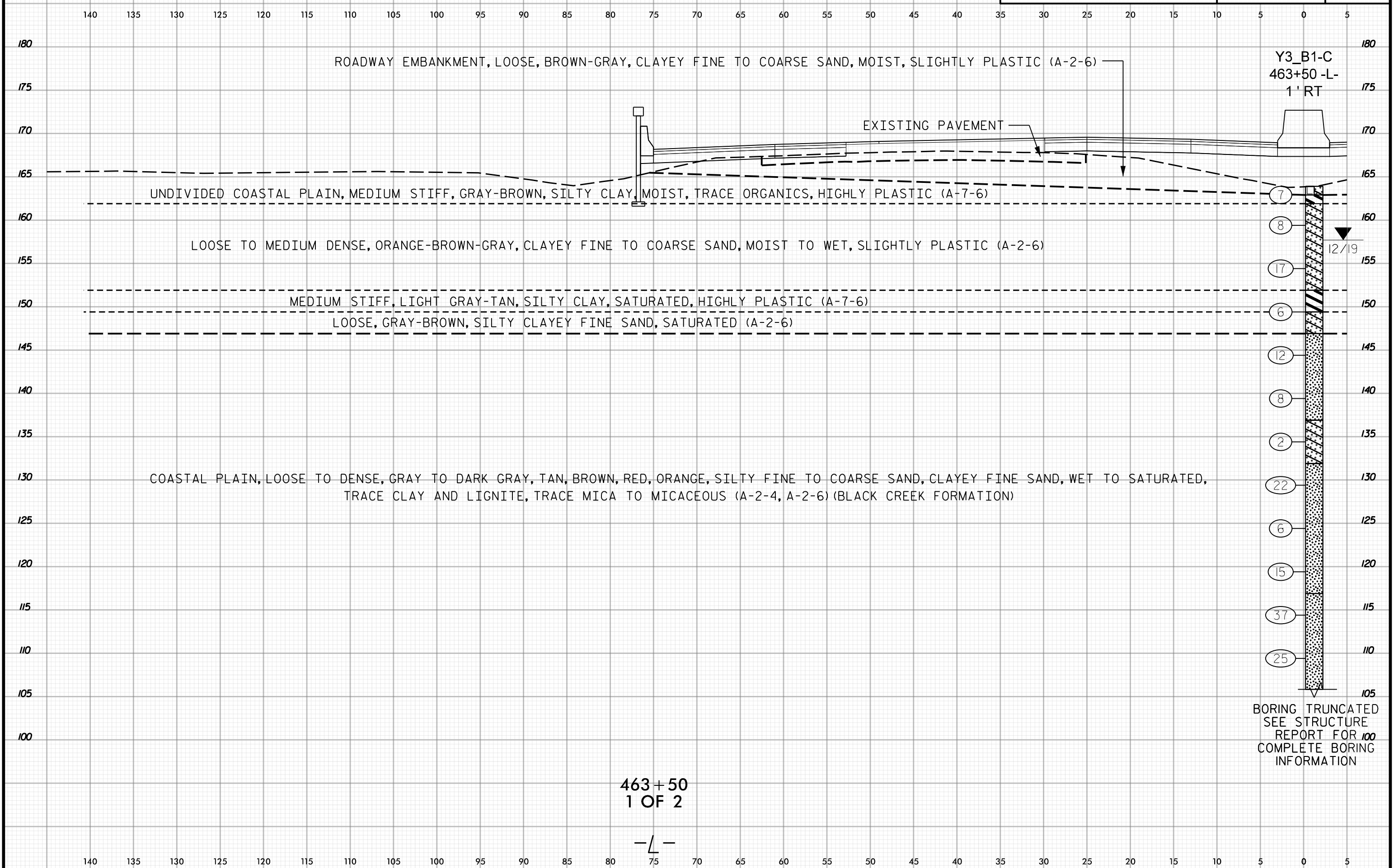
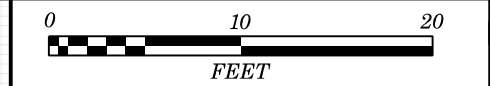

463+50  
1 OF 2

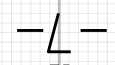

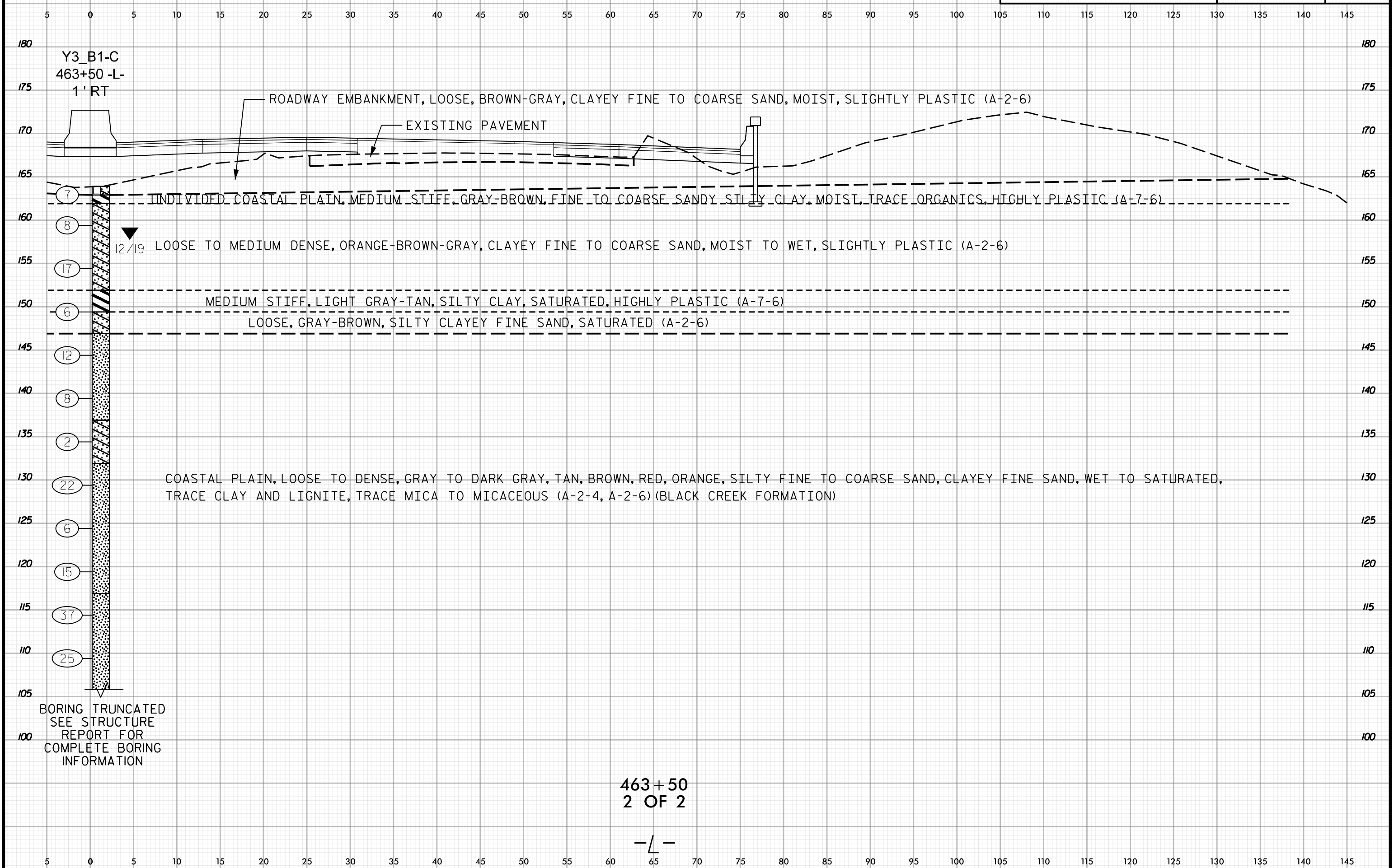



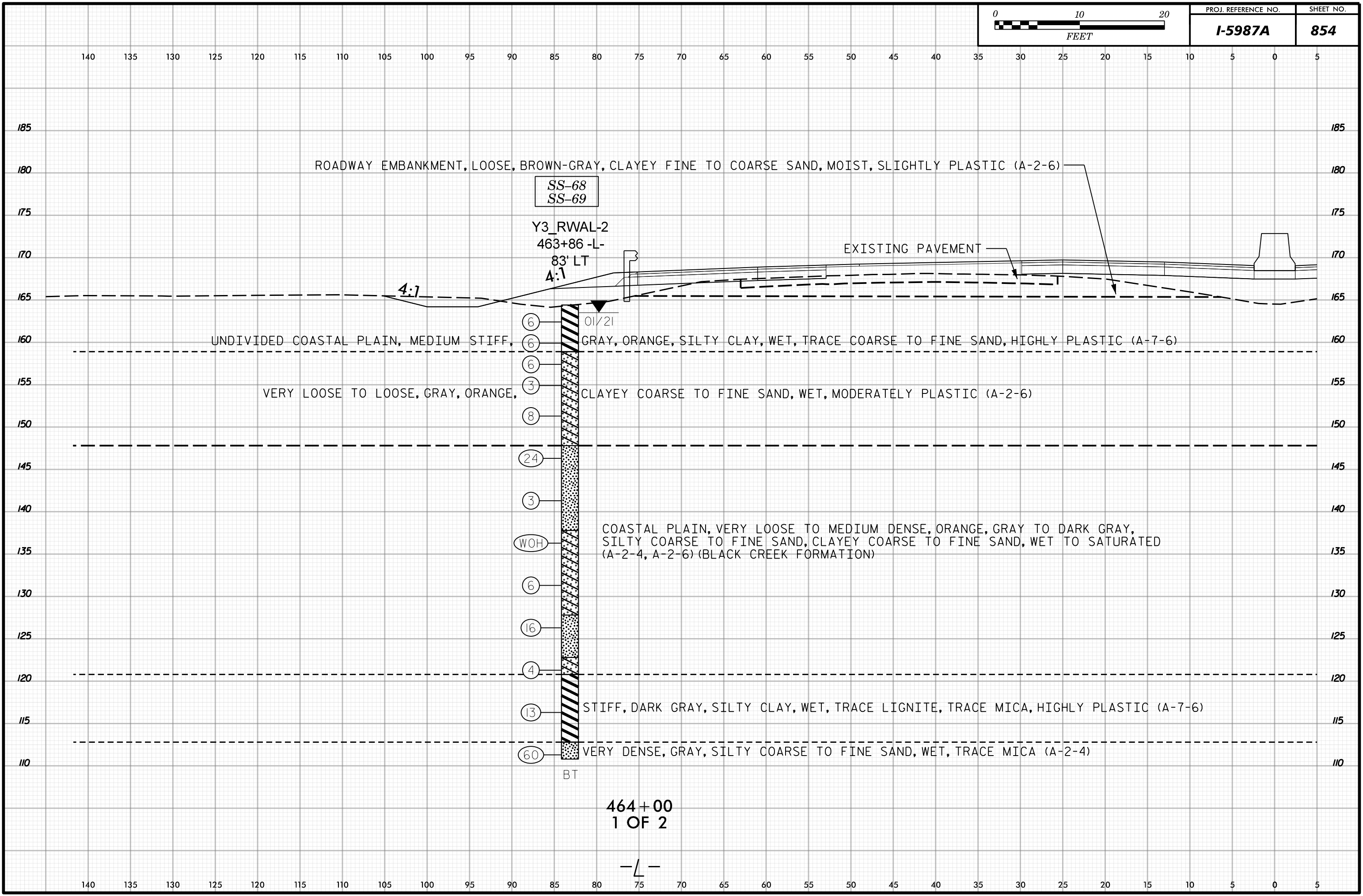
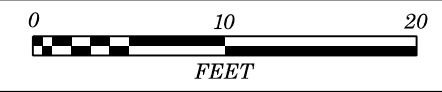

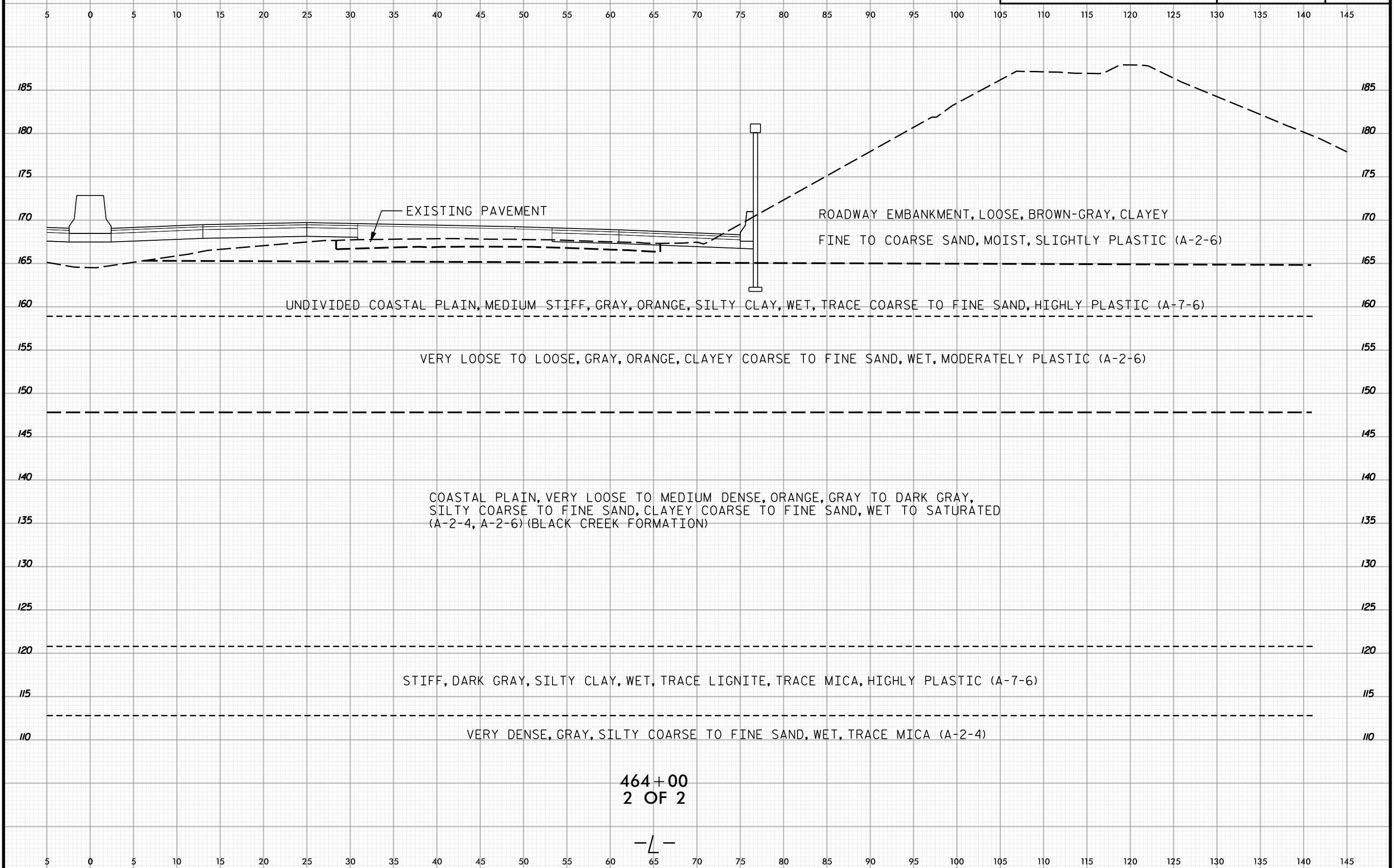

EXISTING PAVEMENT

ROADWAY EMBANKMENT, LOOSE, BROWN-GRAY, CLAYEY  
FINE TO COARSE SAND, MOIST, SLIGHTLY PLASTIC (A-2-6)

UNDIVIDED COASTAL PLAIN, MEDIUM STIFF, GRAY, ORANGE, SILTY CLAY, WET, TRACE COARSE TO FINE SAND, HIGHLY PLASTIC (A-7-6)

VERY LOOSE TO LOOSE, GRAY, ORANGE, CLAYEY COARSE TO FINE SAND, WET, MODERATELY PLASTIC (A-2-6)

COASTAL PLAIN, VERY LOOSE TO MEDIUM DENSE, ORANGE, GRAY TO DARK GRAY,  
SILTY COARSE TO FINE SAND, CLAYEY COARSE TO FINE SAND, WET TO SATURATED  
(A-2-4, A-2-6) (BLACK CREEK FORMATION)

STIFF, DARK GRAY, SILTY CLAY, WET, TRACE LIGNITE, TRACE MICA, HIGHLY PLASTIC (A-7-6)

VERY DENSE, GRAY, SILTY COARSE TO FINE SAND, WET, TRACE MICA (A-2-4)

464+00  
2 OF 2

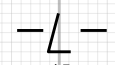

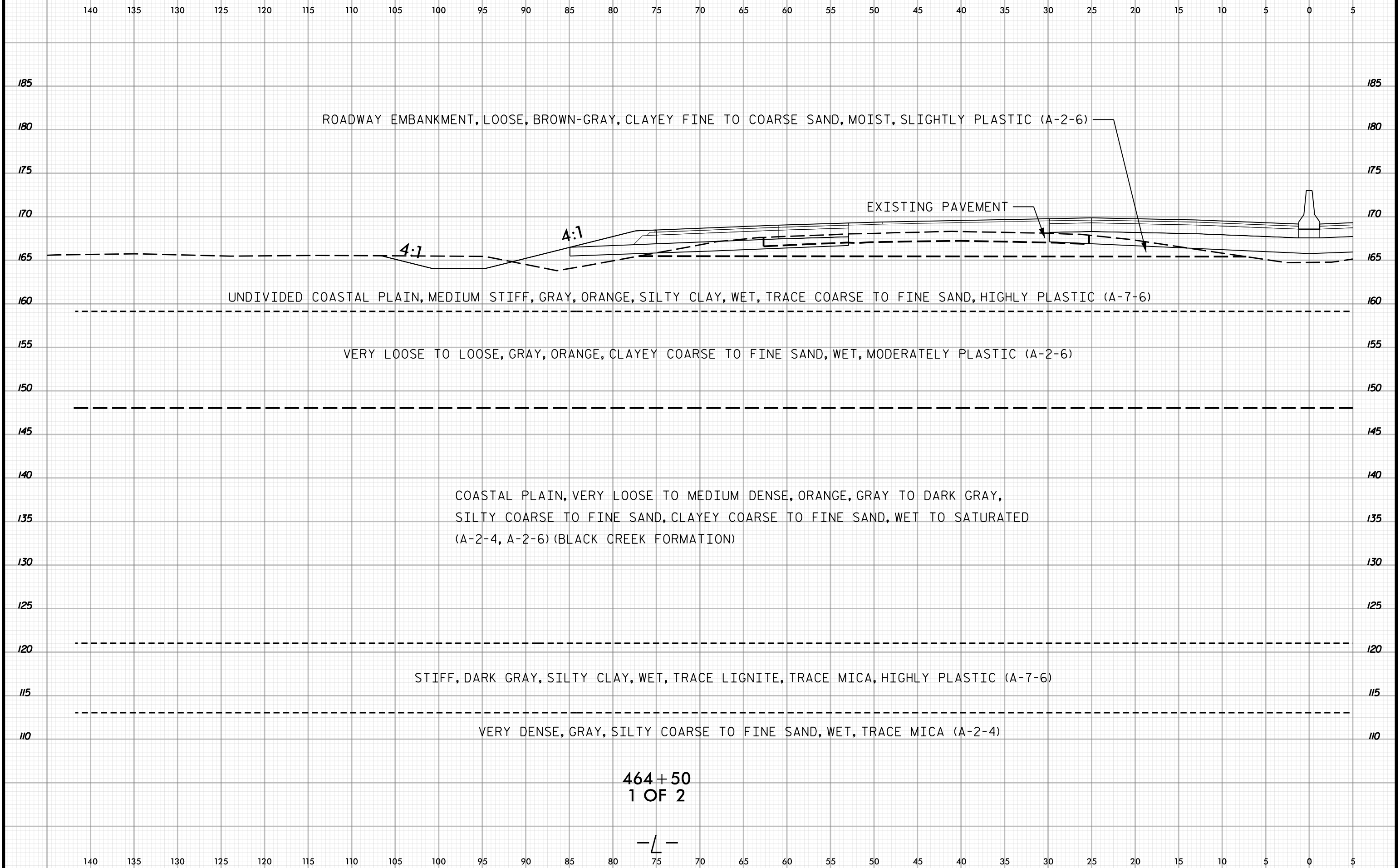

464+50  
1 OF 2

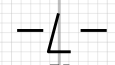

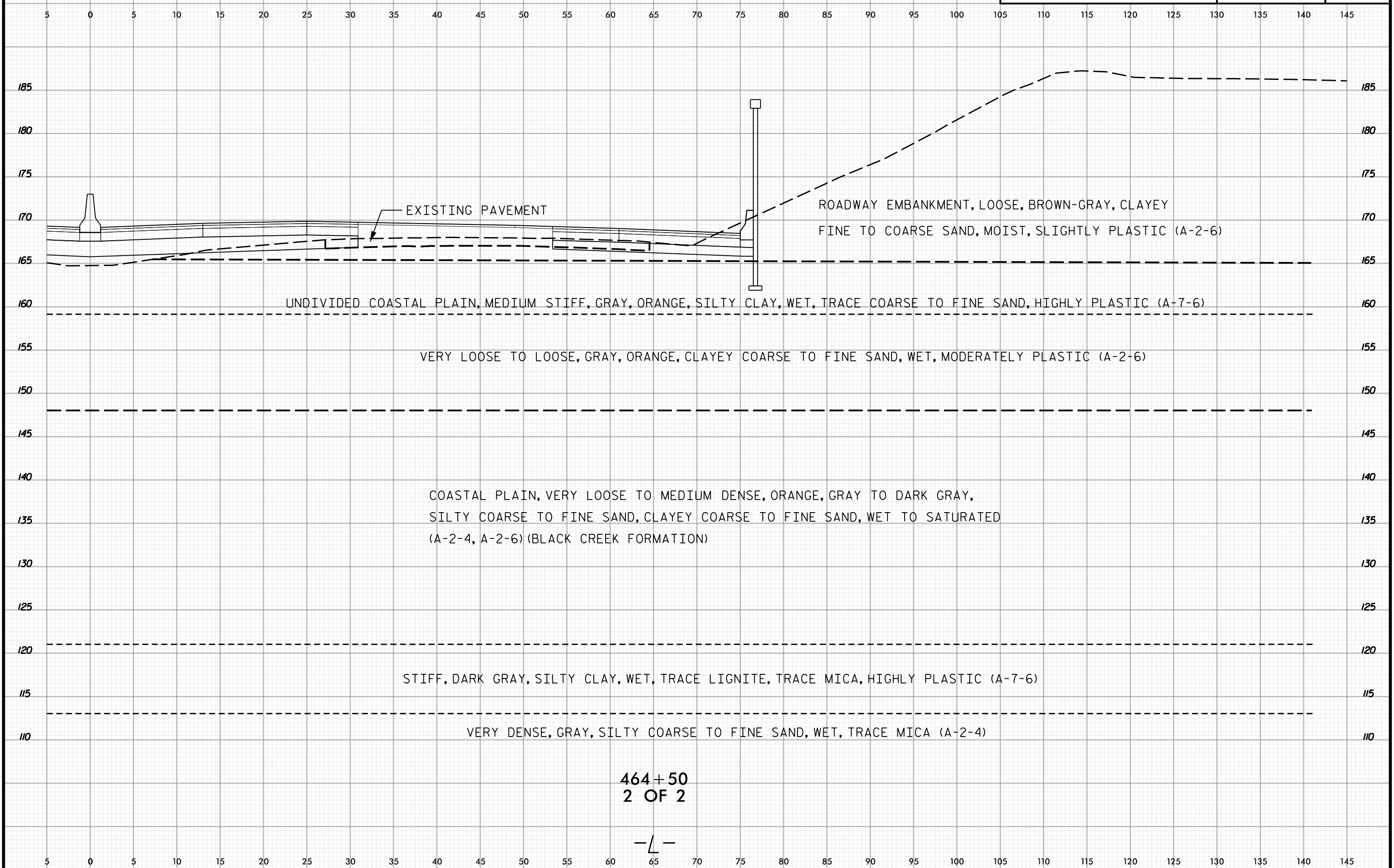

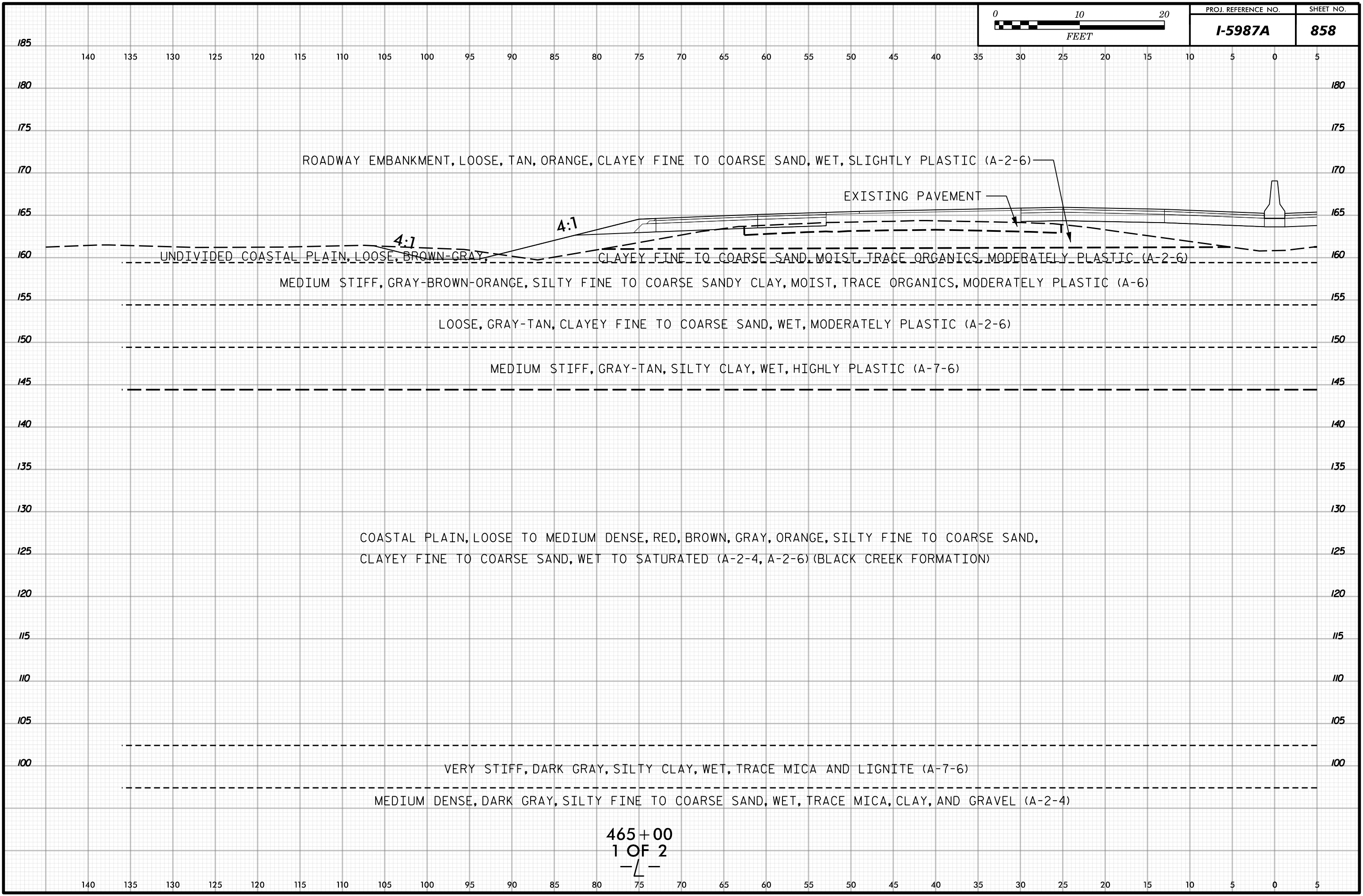

465 + 00  
1 OF 2  
— L —

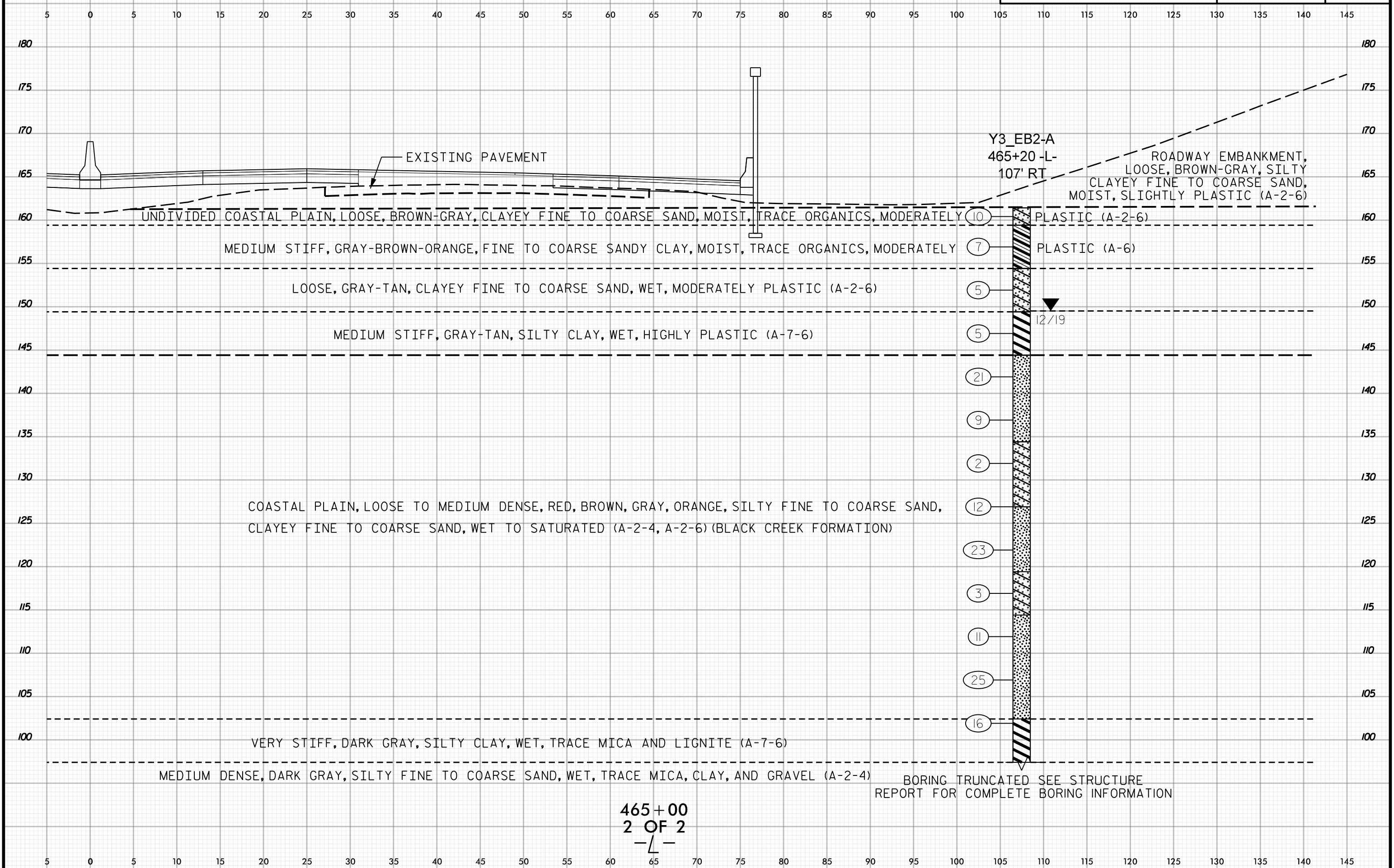
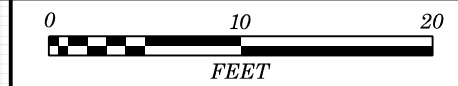

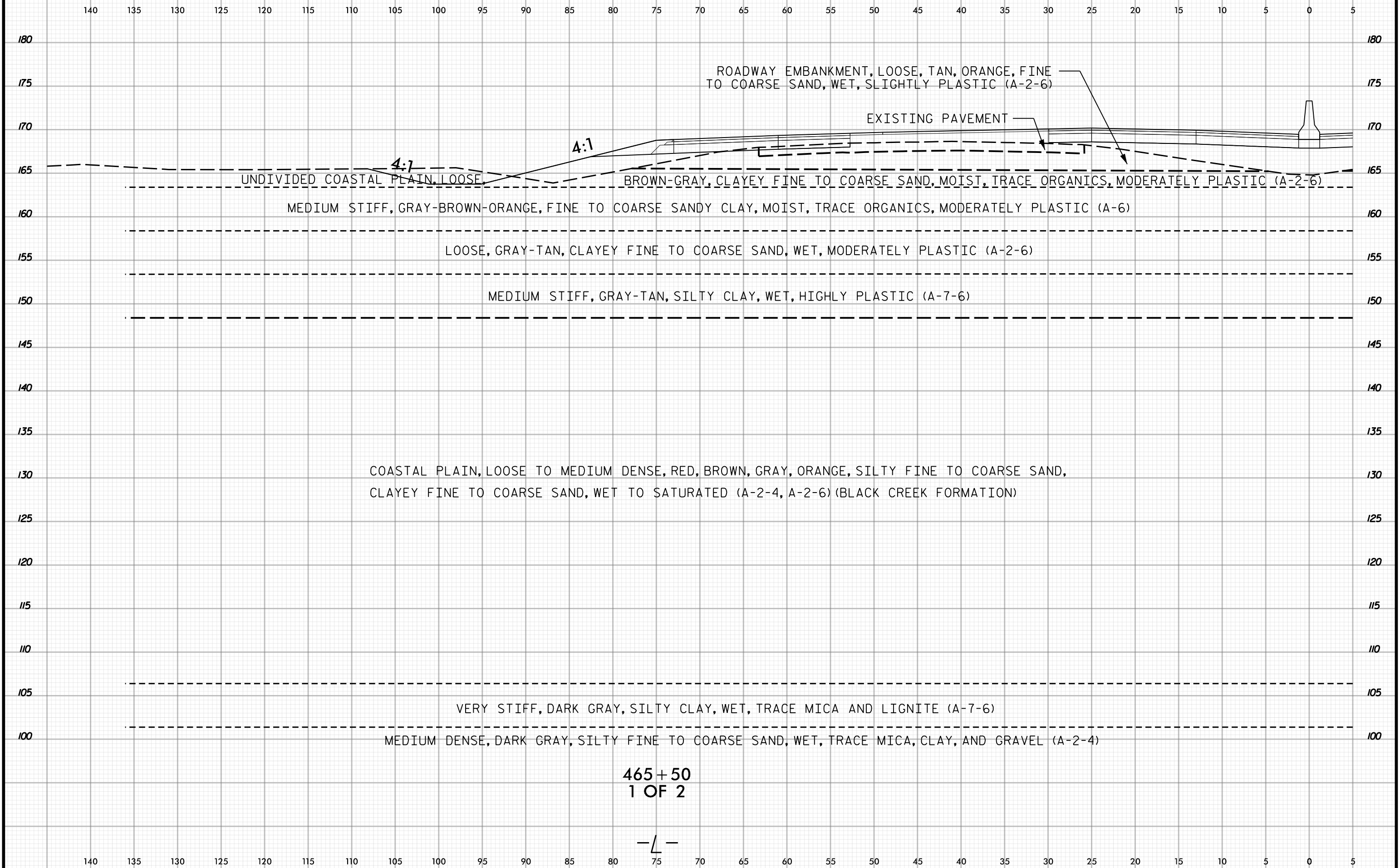

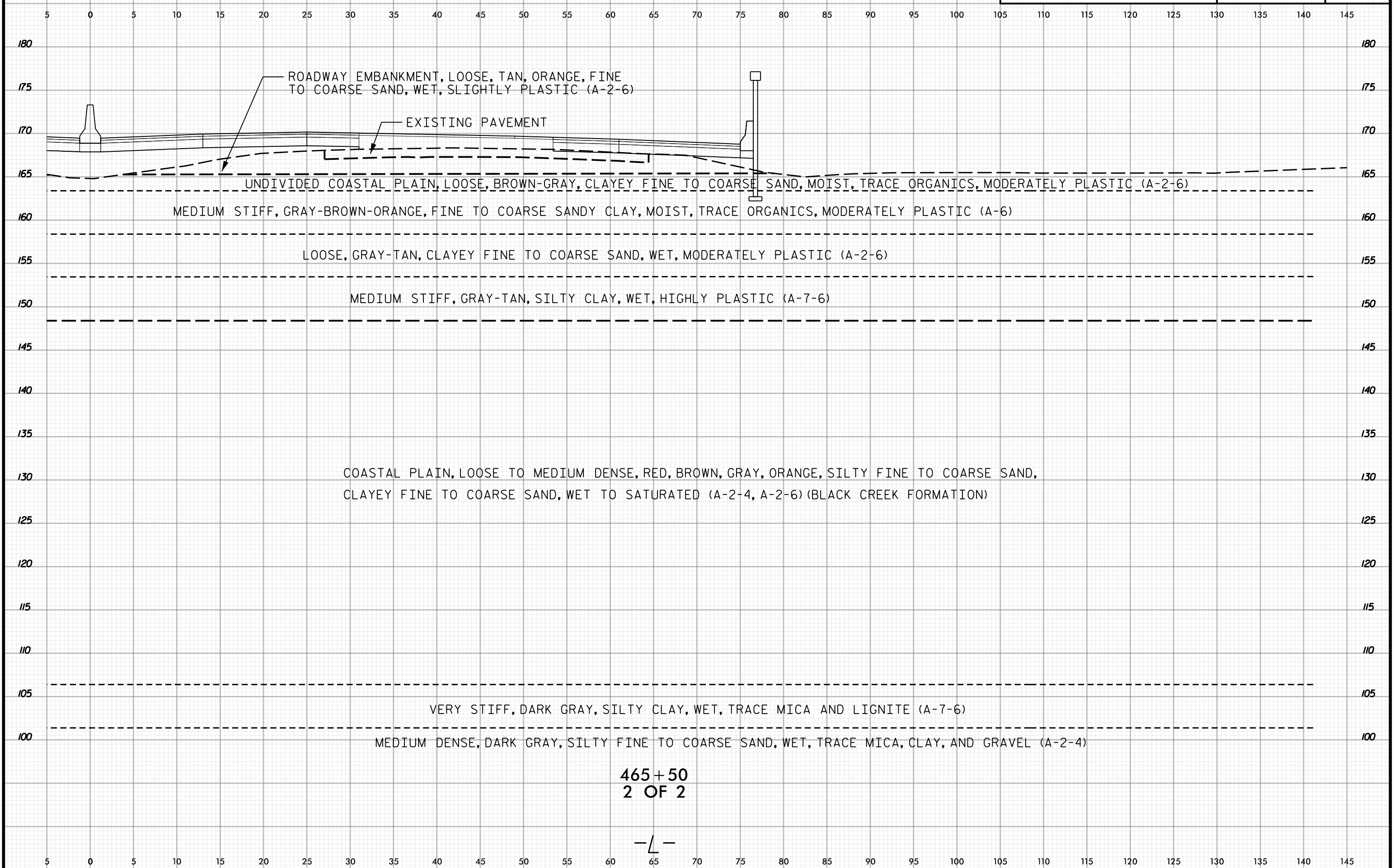

465+50  
2 OF 2

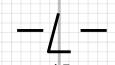



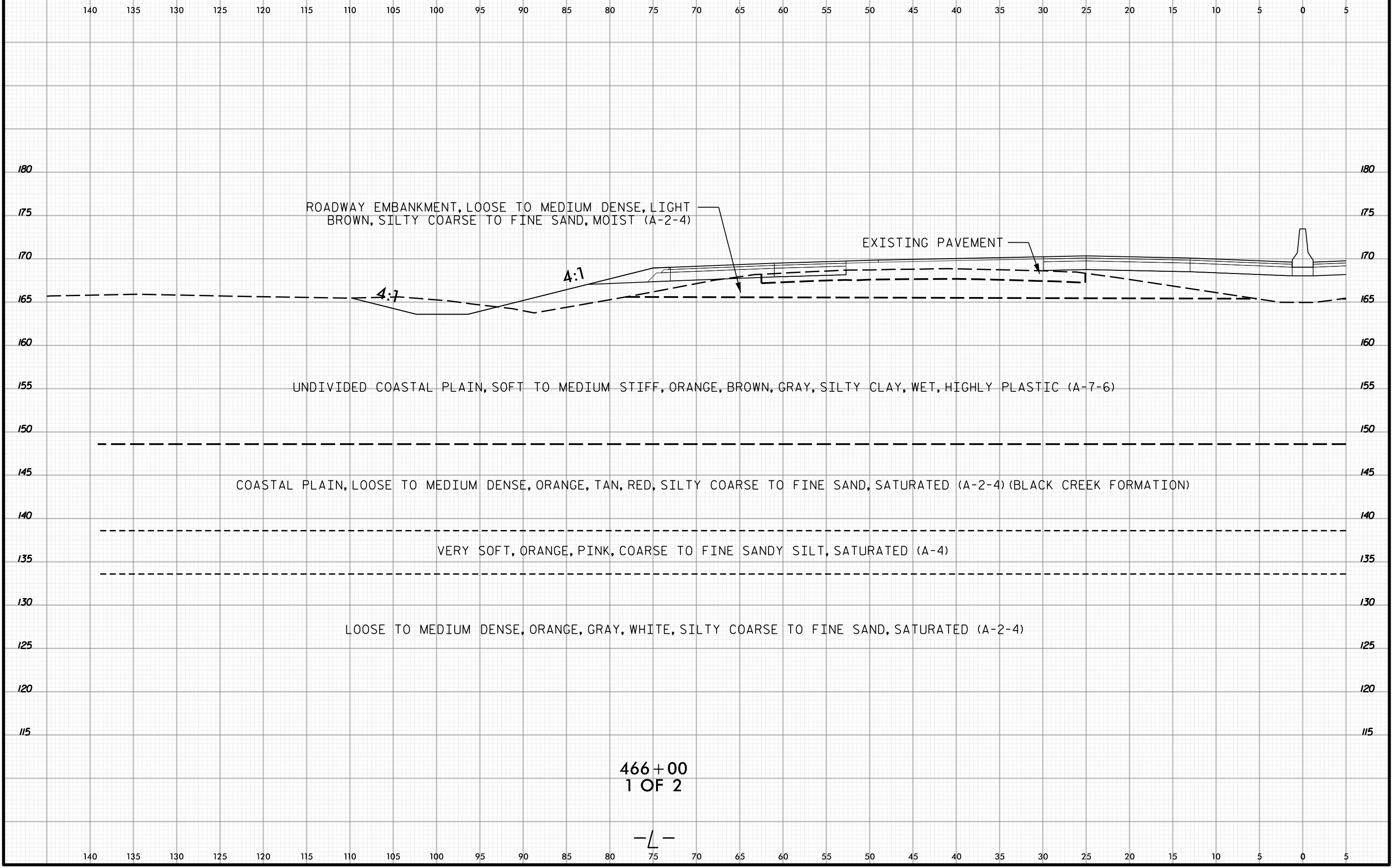

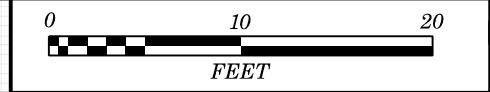

5 0 5 10 15 20 25 30 35 40 45 50 55 60 65 70 75 80 85 90 95 100 105 110 115 120 125 130 135 140 145

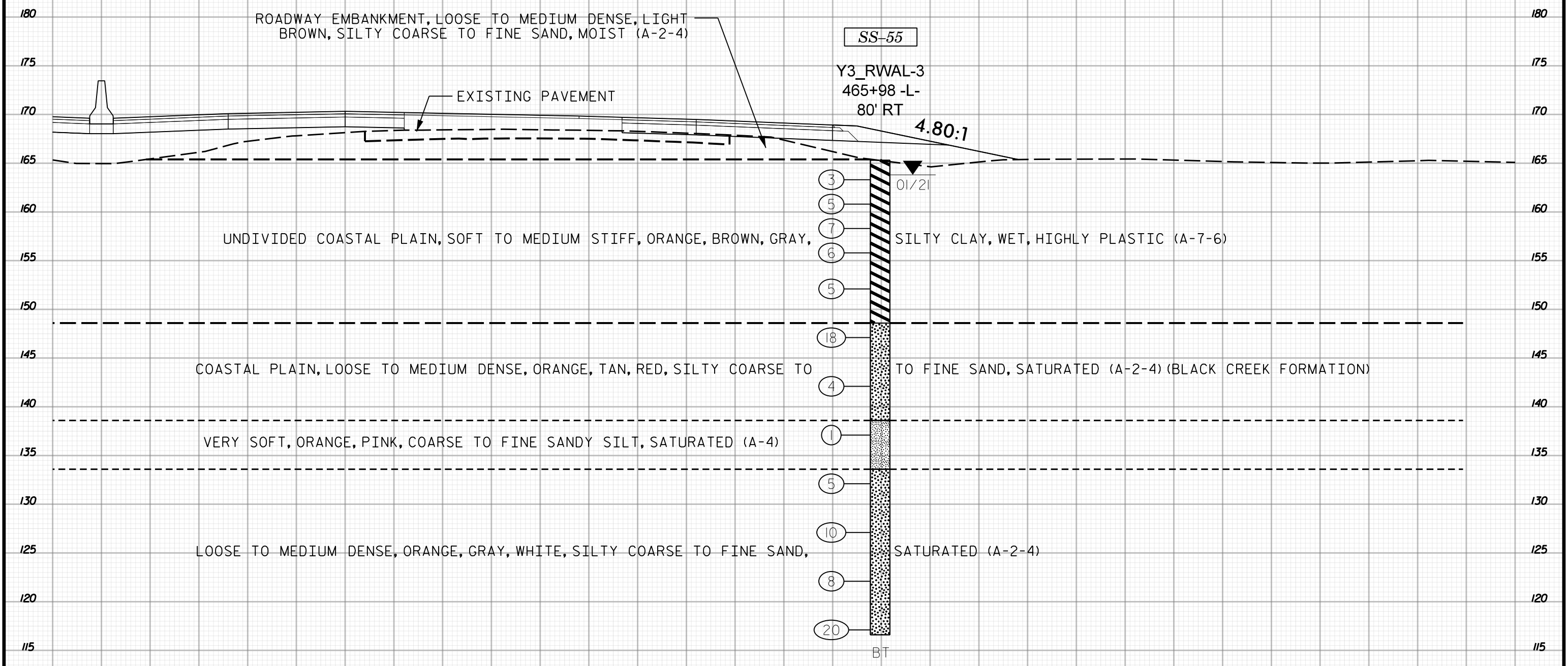

466+00  
2 OF 2

-L-

5 0 5 10 15 20 25 30 35 40 45 50 55 60 65 70 75 80 85 90 95 100 105 110 115 120 125 130 135 140 145

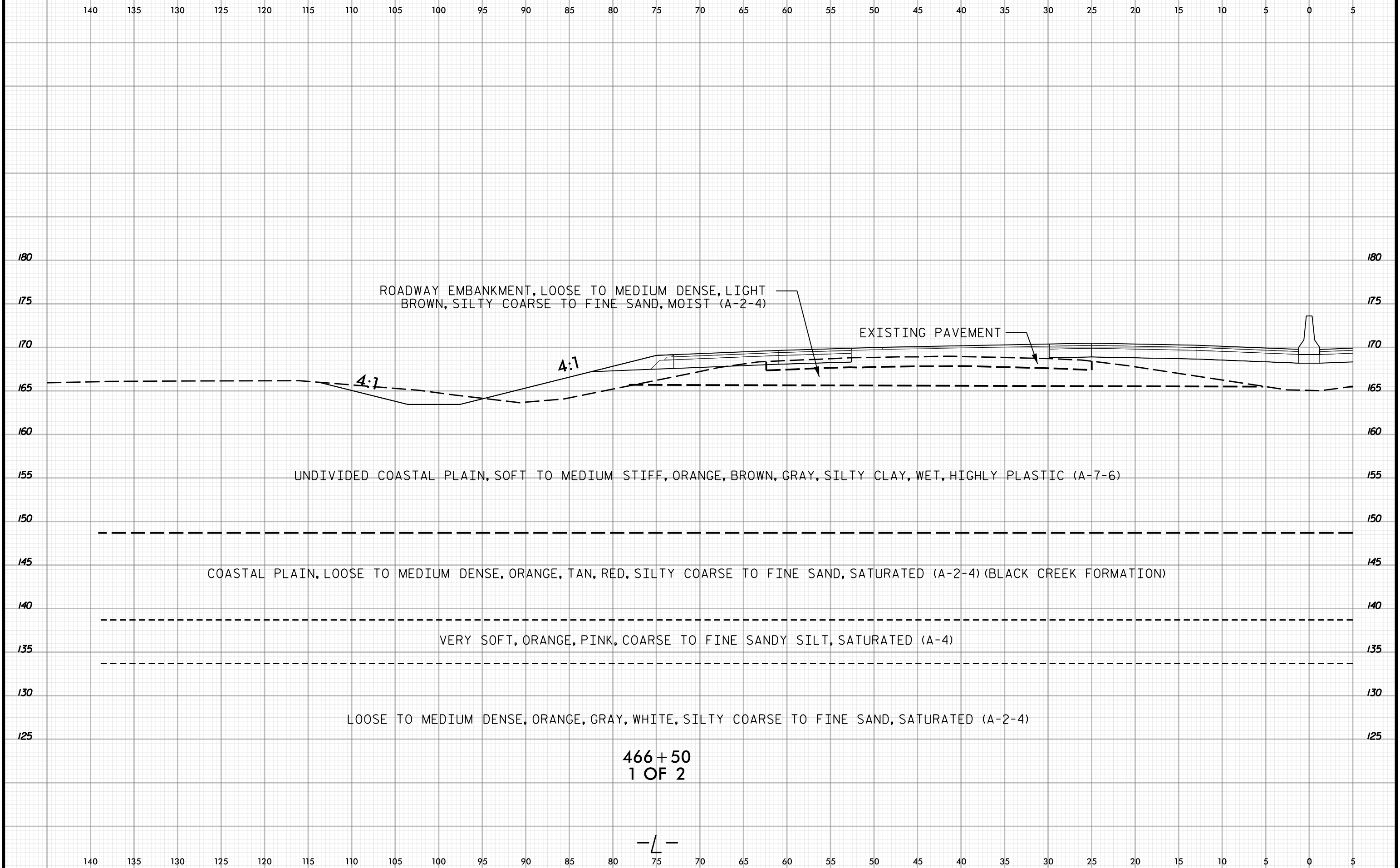



5 0 5 10 15 20 25 30 35 40 45 50 55 60 65 70 75 80 85 90 95 100 105 110 115 120 125 130 135 140 145

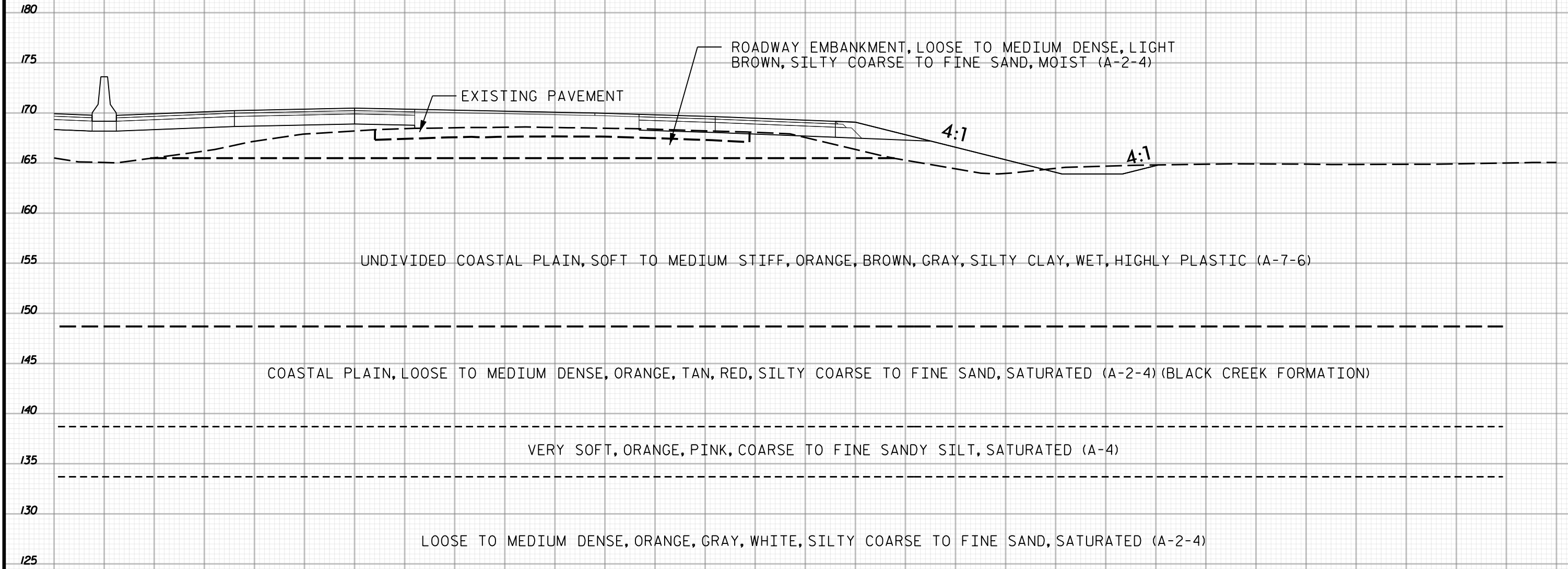

466+50  
2 OF 2

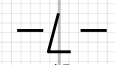

5 0 5 10 15 20 25 30 35 40 45 50 55 60 65 70 75 80 85 90 95 100 105 110 115 120 125 130 135 140 145



140 135 130 125 120 115 110 105 100 95 90 85 80 75 70 65 60 55 50 45 40 35 30 25 20 15 10 5 0 5

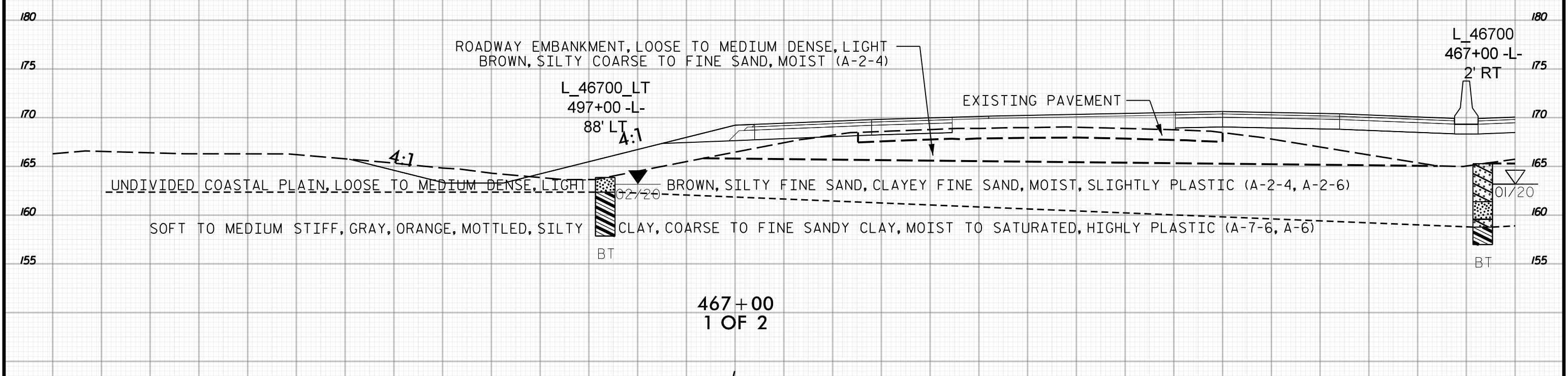
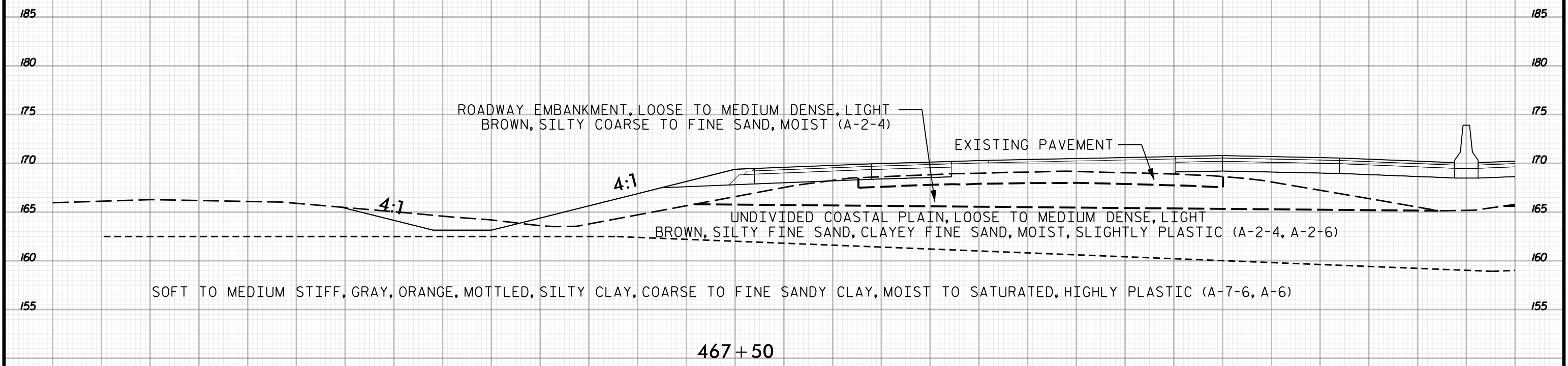

140 135 130 125 120 115 110 105 100 95 90 85 80 75 70 65 60 55 50 45 40 35 30 25 20 15 10 5 0 5

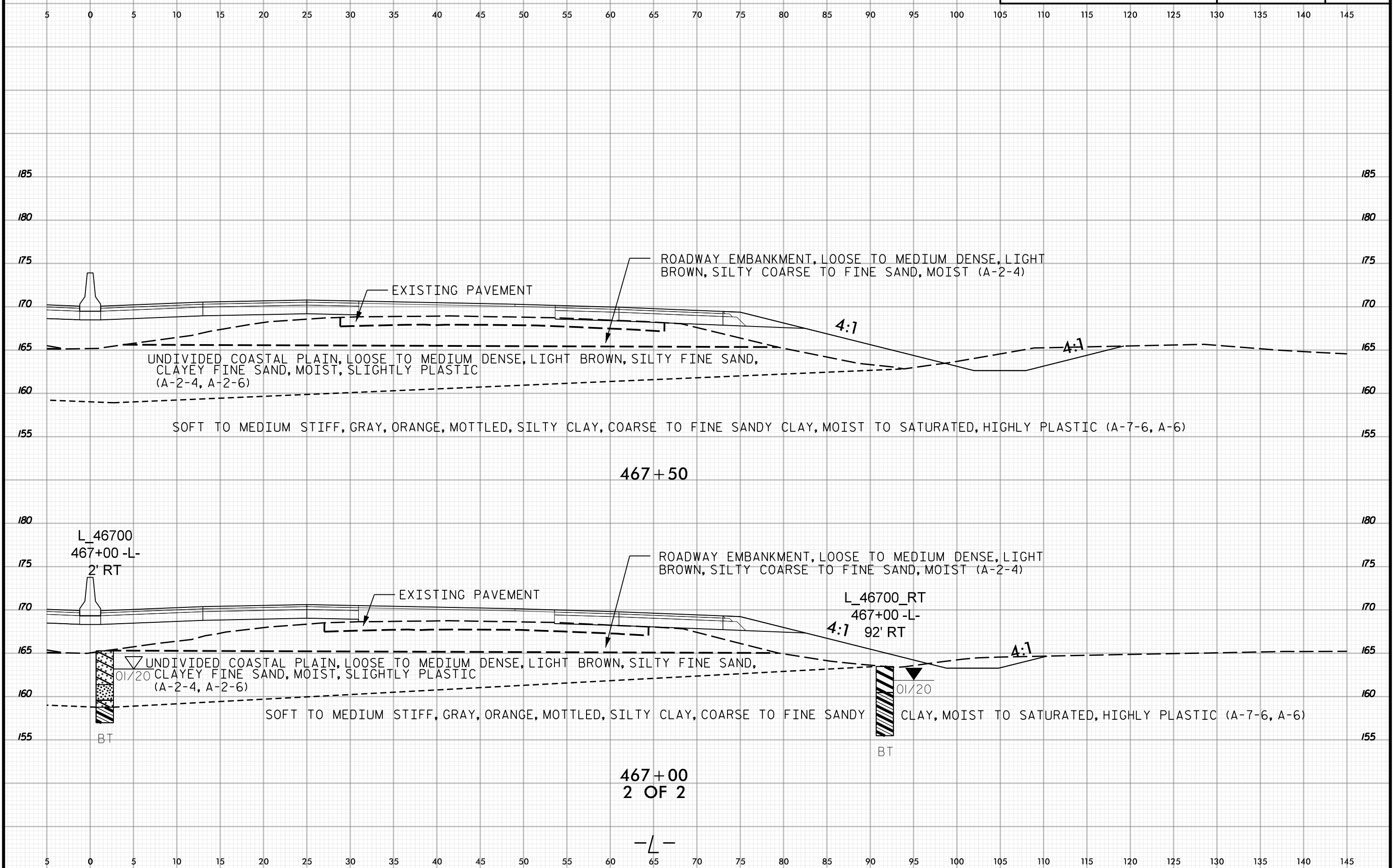

467+50

L\_46700  
467+00 -L-  
2' RT

ROADWAY EMBANKMENT, LOOSE TO MEDIUM DENSE, LIGHT BROWN, SILTY COARSE TO FINE SAND, MOIST (A-2-4)

EXISTING PAVEMENT

L\_46700\_RT  
467+00 -L-  
4:1 92' RT

UNDIVIDED COASTAL PLAIN, LOOSE TO MEDIUM DENSE, LIGHT BROWN, SILTY FINE SAND, CLAYEY FINE SAND, MOIST, SLIGHTLY PLASTIC (A-2-4, A-2-6)

SOFT TO MEDIUM STIFF, GRAY, ORANGE, MOTTLED, SILTY CLAY, COARSE TO FINE SANDY CLAY, MOIST TO SATURATED, HIGHLY PLASTIC (A-7-6, A-6)

BT

BT

467+00  
2 OF 2

-L-



140 135 130 125 120 115 110 105 100 95 90 85 80 75 70 65 60 55 50 45 40 35 30 25 20 15 10 5 0 5

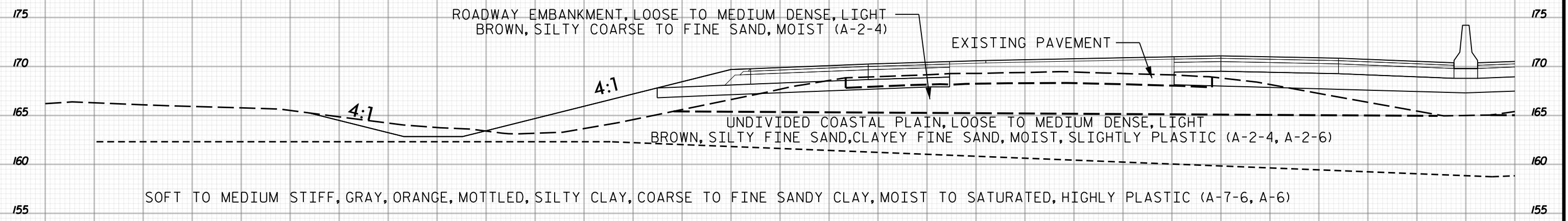

468+50

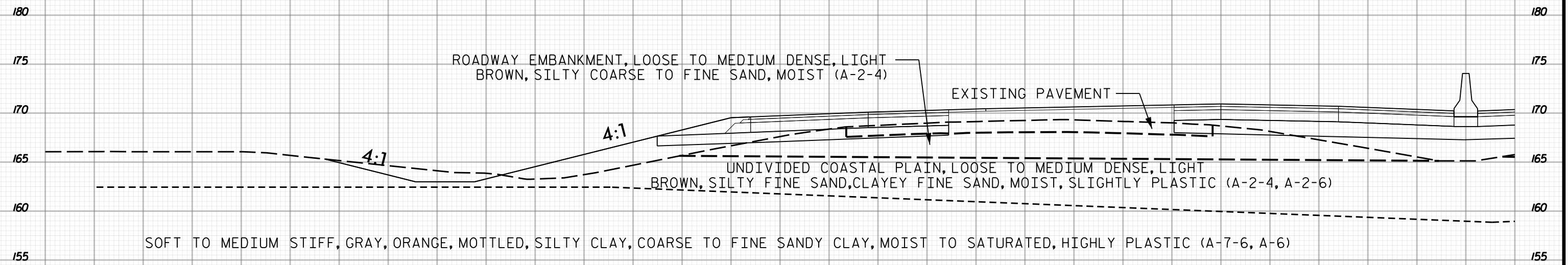

468+00  
1 OF 2

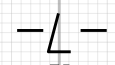

140 135 130 125 120 115 110 105 100 95 90 85 80 75 70 65 60 55 50 45 40 35 30 25 20 15 10 5 0 5

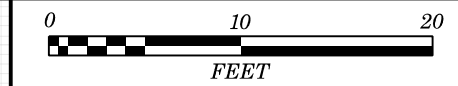

5 0 5 10 15 20 25 30 35 40 45 50 55 60 65 70 75 80 85 90 95 100 105 110 115 120 125 130 135 140 145

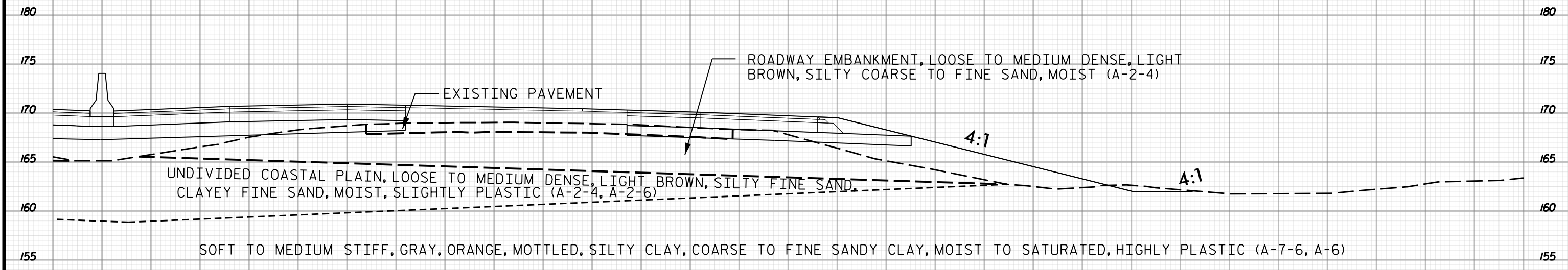
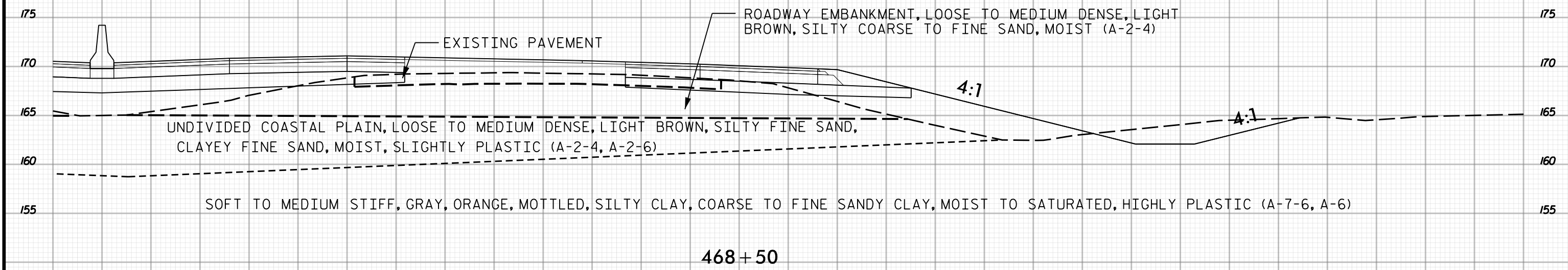

2 OF 2

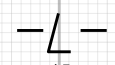

5 0 5 10 15 20 25 30 35 40 45 50 55 60 65 70 75 80 85 90 95 100 105 110 115 120 125 130 135 140 145





140 135 130 125 120 115 110 105 100 95 90 85 80 75 70 65 60 55 50 45 40 35 30 25 20 15 10 5 0 5

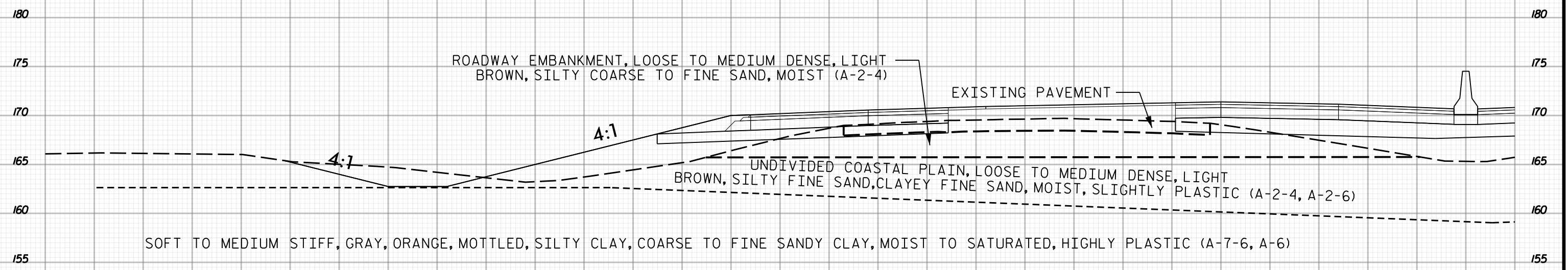

469+50

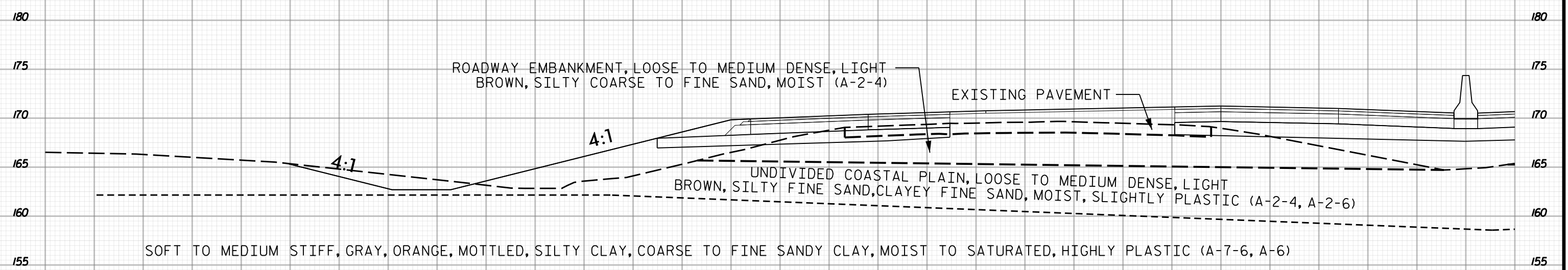

469+00  
1 OF 2

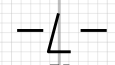

140 135 130 125 120 115 110 105 100 95 90 85 80 75 70 65 60 55 50 45 40 35 30 25 20 15 10 5 0 5

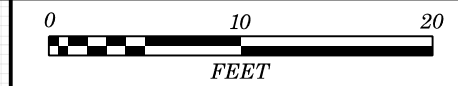

5 0 5 10 15 20 25 30 35 40 45 50 55 60 65 70 75 80 85 90 95 100 105 110 115 120 125 130 135 140 145

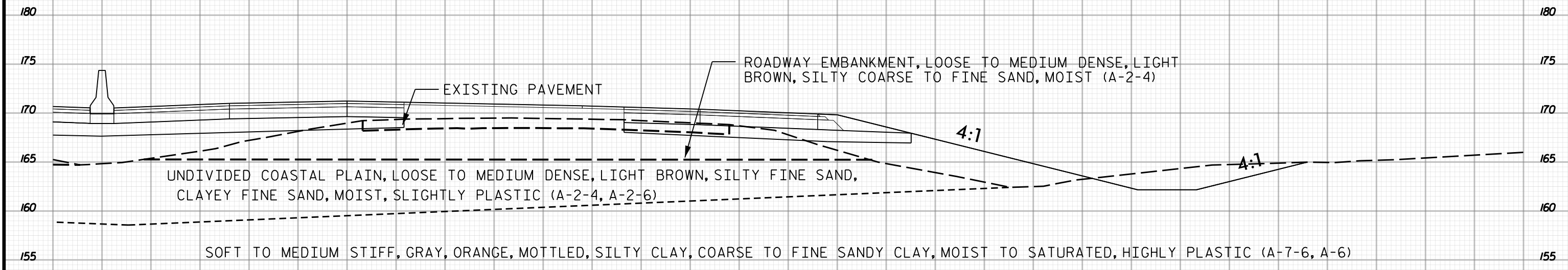
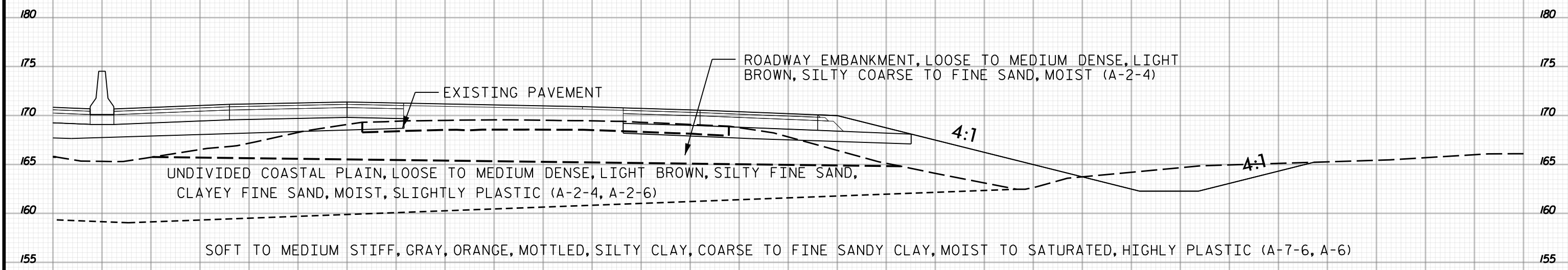

469 + 00  
2 OF 2

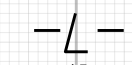

5 0 5 10 15 20 25 30 35 40 45 50 55 60 65 70 75 80 85 90 95 100 105 110 115 120 125 130 135 140 145



140 135 130 125 120 115 110 105 100 95 90 85 80 75 70 65 60 55 50 45 40 35 30 25 20 15 10 5 0 5

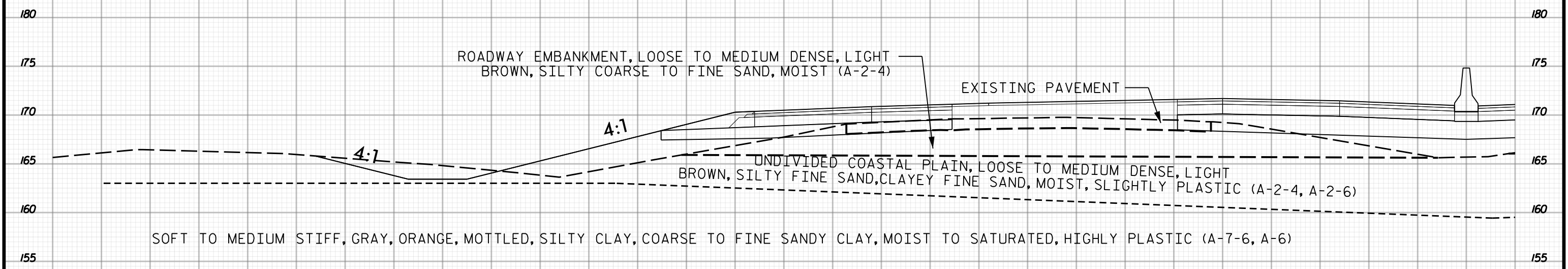

470+50

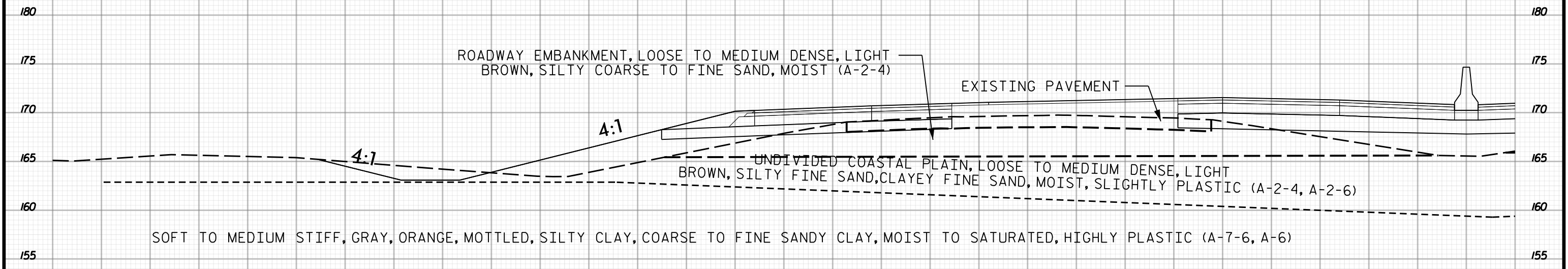

470+00  
1 OF 2

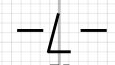

140 135 130 125 120 115 110 105 100 95 90 85 80 75 70 65 60 55 50 45 40 35 30 25 20 15 10 5 0 5

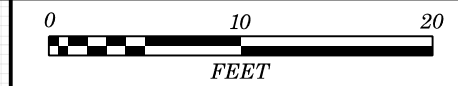

5 0 5 10 15 20 25 30 35 40 45 50 55 60 65 70 75 80 85 90 95 100 105 110 115 120 125 130 135 140 145

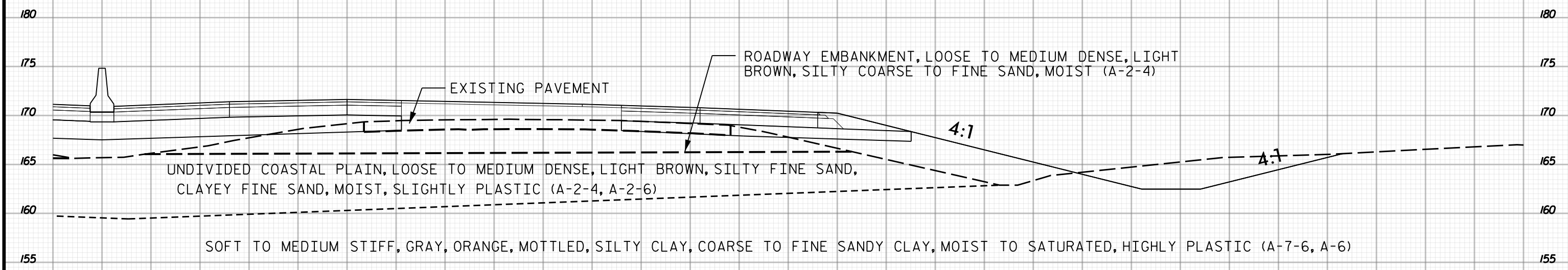

470+50

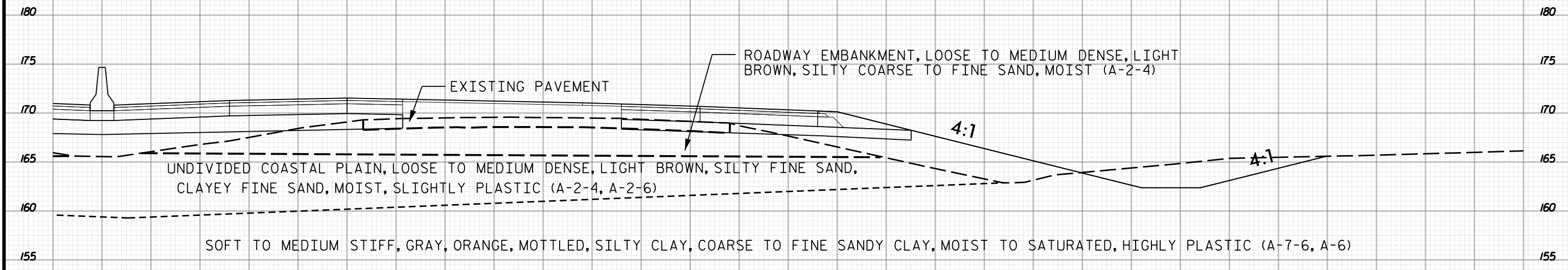

470+00  
2 OF 2

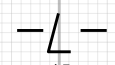

5 0 5 10 15 20 25 30 35 40 45 50 55 60 65 70 75 80 85 90 95 100 105 110 115 120 125 130 135 140 145



140 135 130 125 120 115 110 105 100 95 90 85 80 75 70 65 60 55 50 45 40 35 30 25 20 15 10 5 0 5

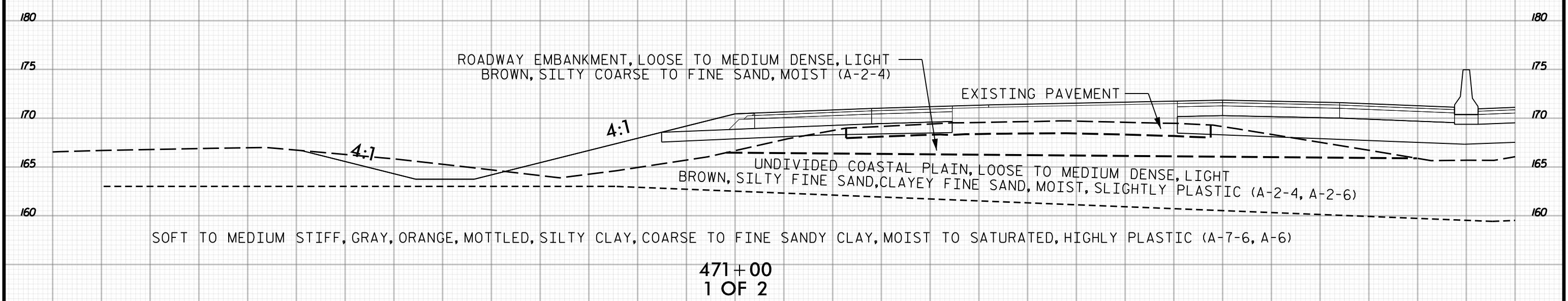
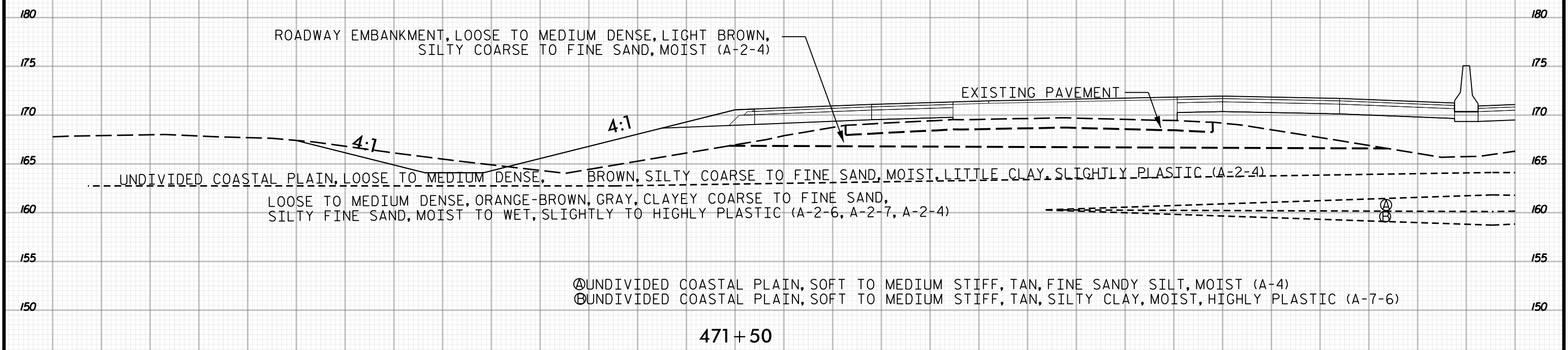

140 135 130 125 120 115 110 105 100 95 90 85 80 75 70 65 60 55 50 45 40 35 30 25 20 15 10 5 0 5



5 0 5 10 15 20 25 30 35 40 45 50 55 60 65 70 75 80 85 90 95 100 105 110 115 120 125 130 135 140 145

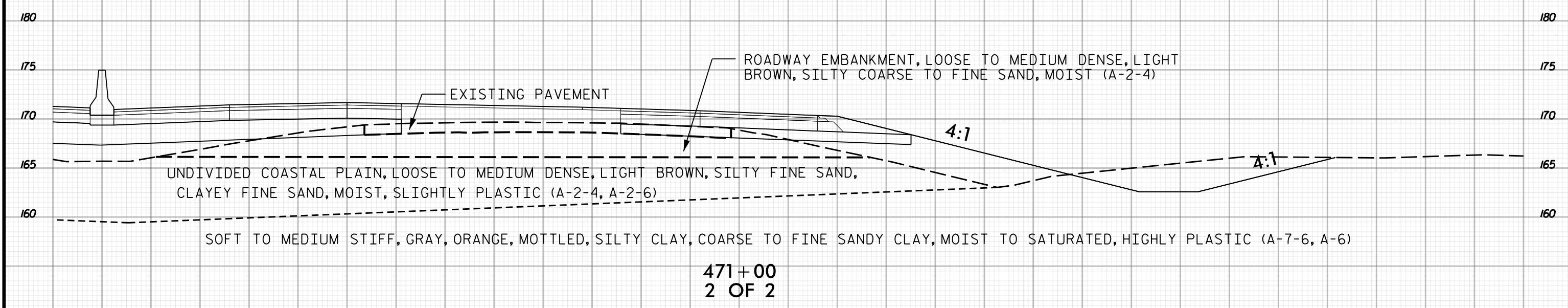
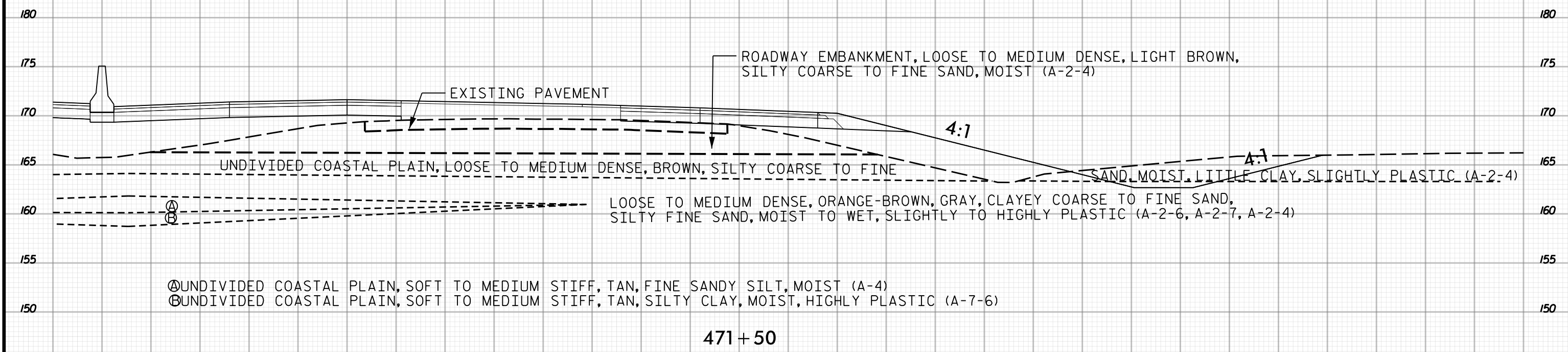

5 0 5 10 15 20 25 30 35 40 45 50 55 60 65 70 75 80 85 90 95 100 105 110 115 120 125 130 135 140 145



140 135 130 125 120 115 110 105 100 95 90 85 80 75 70 65 60 55 50 45 40 35 30 25 20 15 10 5 0 5

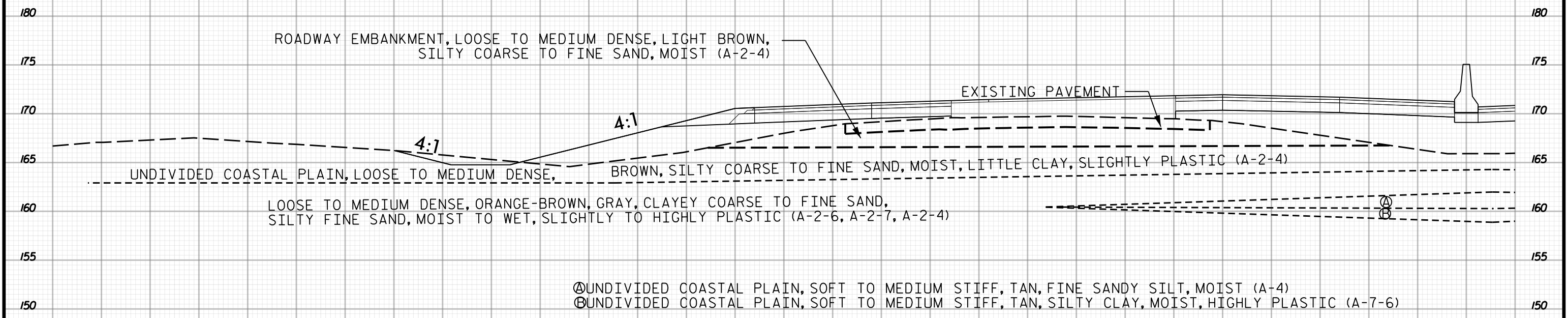

472 + 50

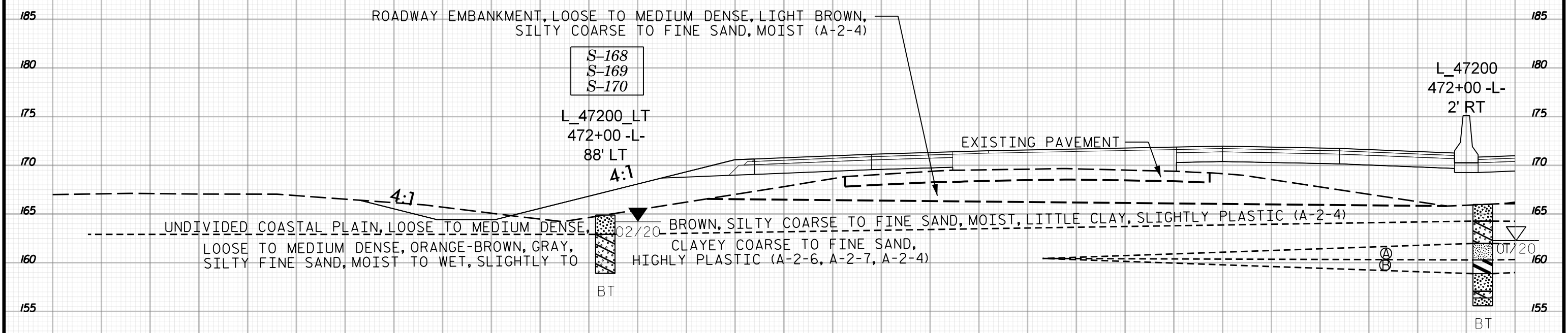

472 + 00  
1 OF 2

140 135 130 125 120 115 110 105 100 95 90 85 80 75 70 65 60 55 50 45 40 35 30 25 20 15 10 5 0 5

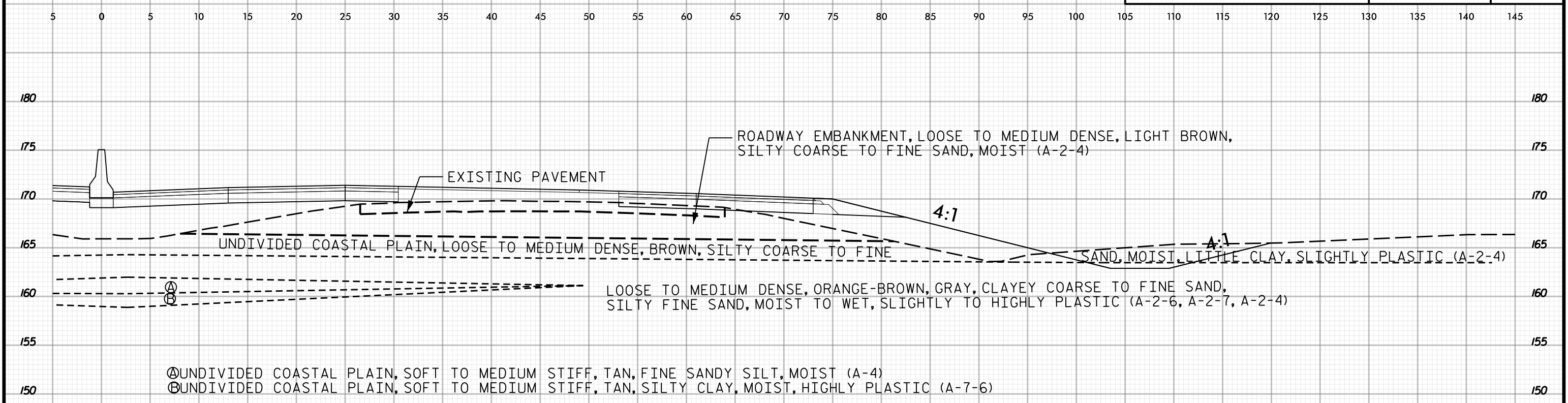
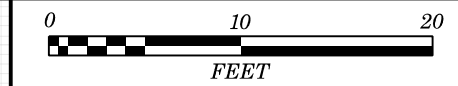

472 + 50

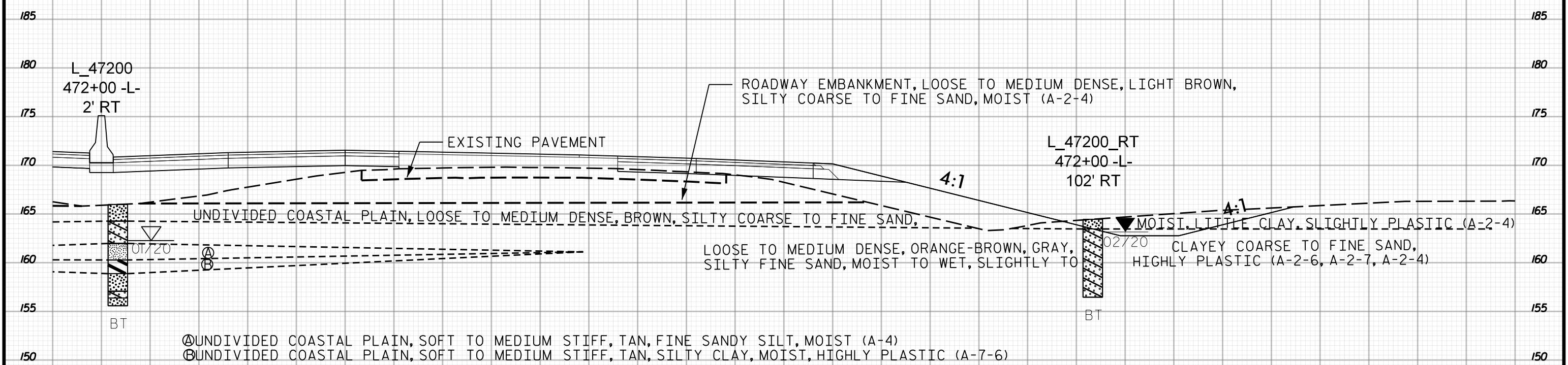

472 + 00  
2 OF 2

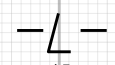





140 135 130 125 120 115 110 105 100 95 90 85 80 75 70 65 60 55 50 45 40 35 30 25 20 15 10 5 0 5

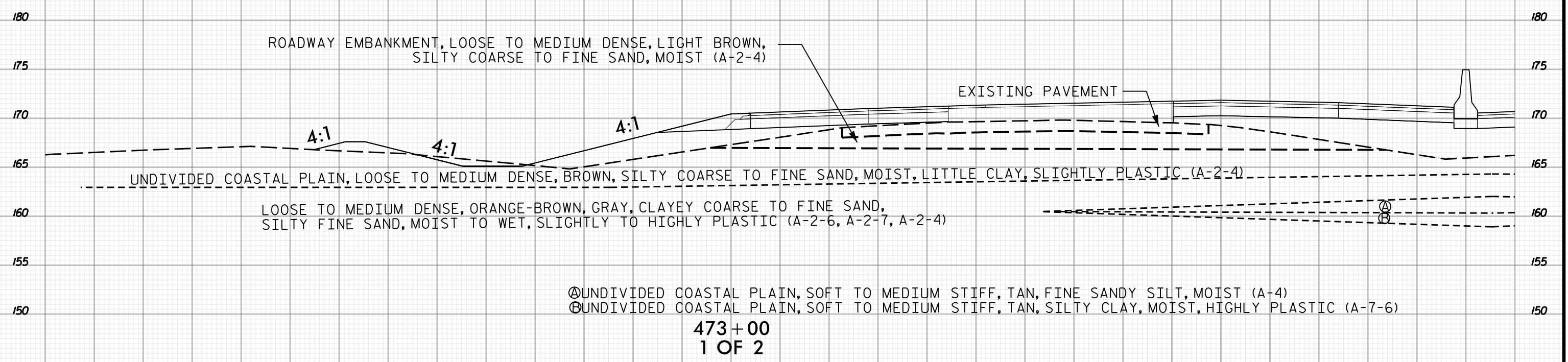
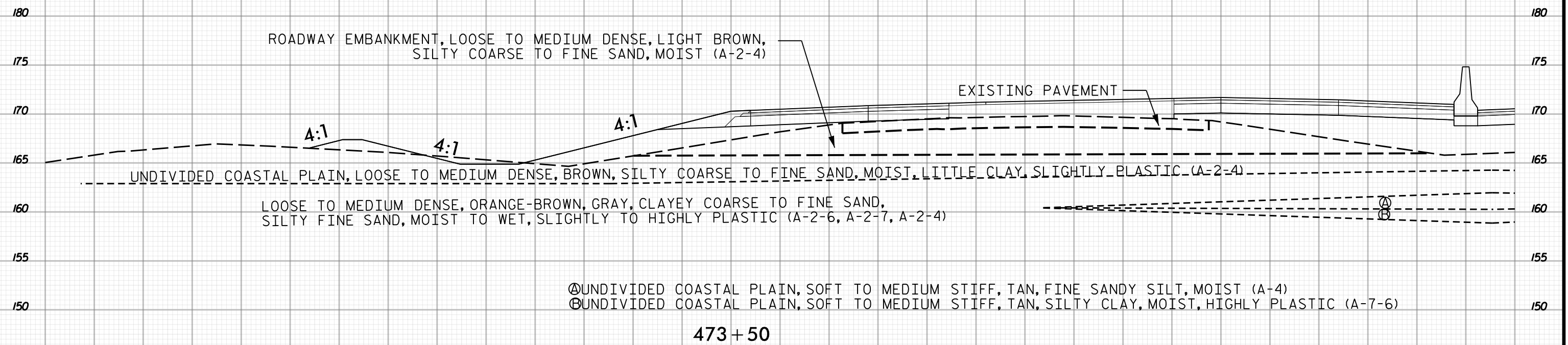

140 135 130 125 120 115 110 105 100 95 90 85 80 75 70 65 60 55 50 45 40 35 30 25 20 15 10 5 0 5



5 0 5 10 15 20 25 30 35 40 45 50 55 60 65 70 75 80 85 90 95 100 105 110 115 120 125 130 135 140 145

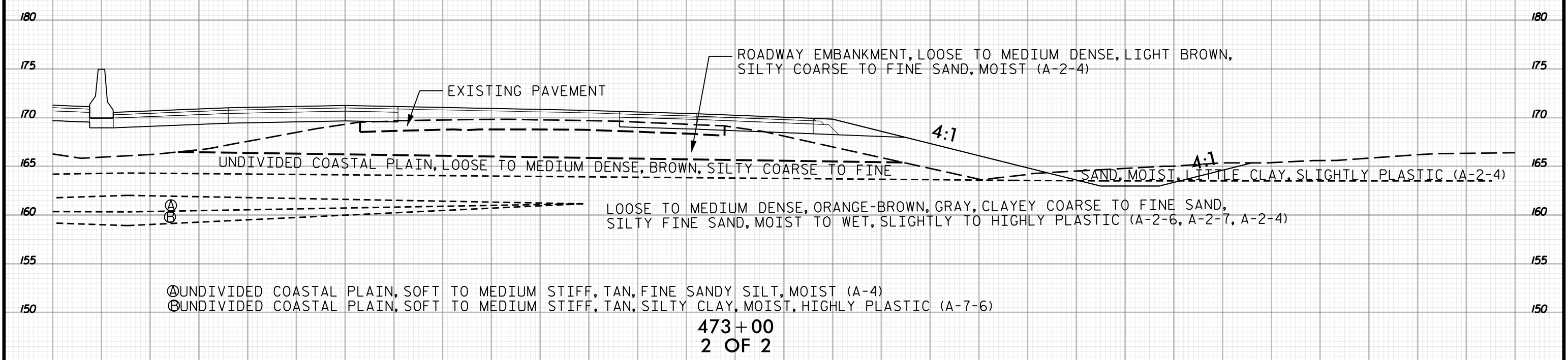
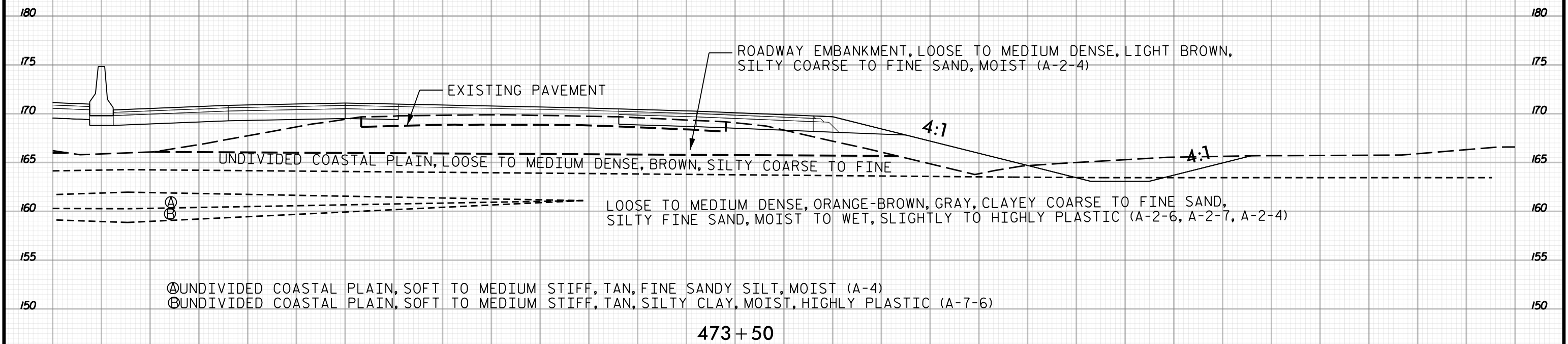

5 0 5 10 15 20 25 30 35 40 45 50 55 60 65 70 75 80 85 90 95 100 105 110 115 120 125 130 135 140 145



140 135 130 125 120 115 110 105 100 95 90 85 80 75 70 65 60 55 50 45 40 35 30 25 20 15 10 5 0 5

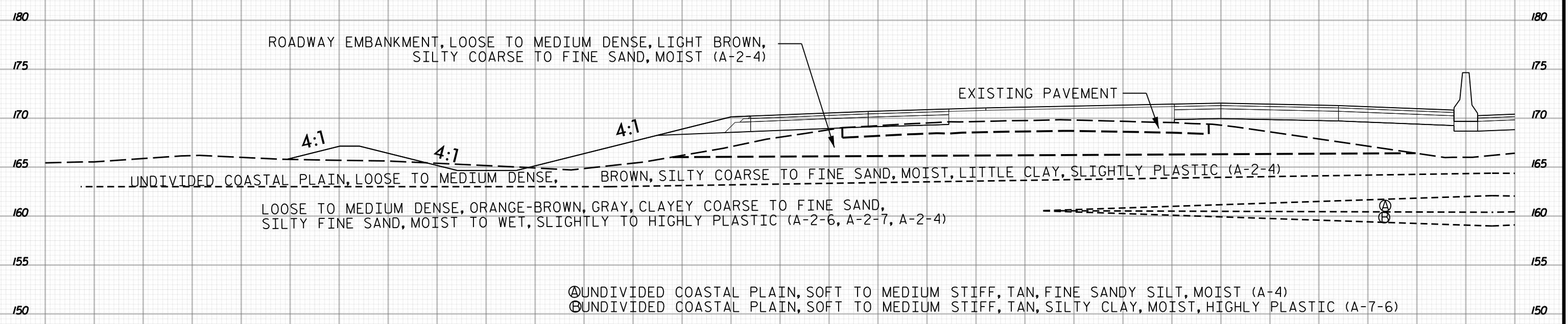
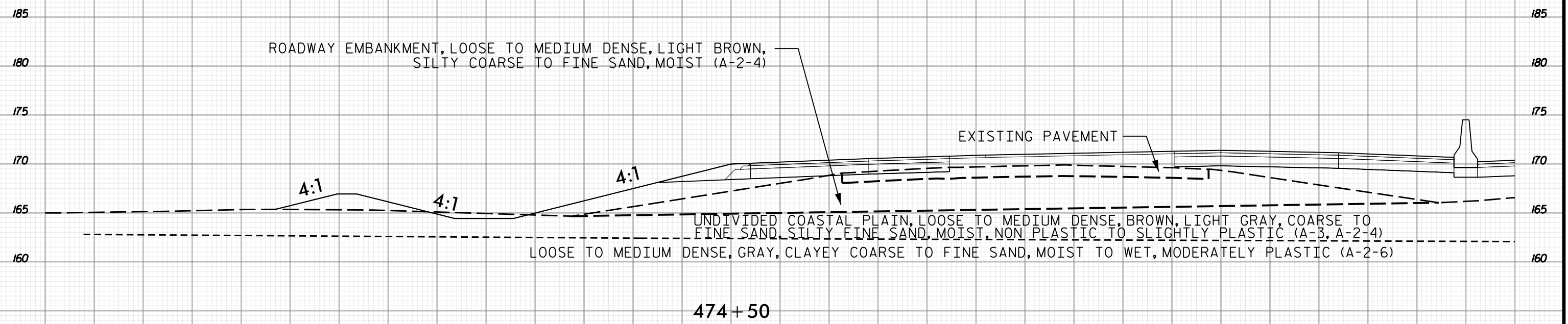

140 135 130 125 120 115 110 105 100 95 90 85 80 75 70 65 60 55 50 45 40 35 30 25 20 15 10 5 0 5



5 0 5 10 15 20 25 30 35 40 45 50 55 60 65 70 75 80 85 90 95 100 105 110 115 120 125 130 135 140 145

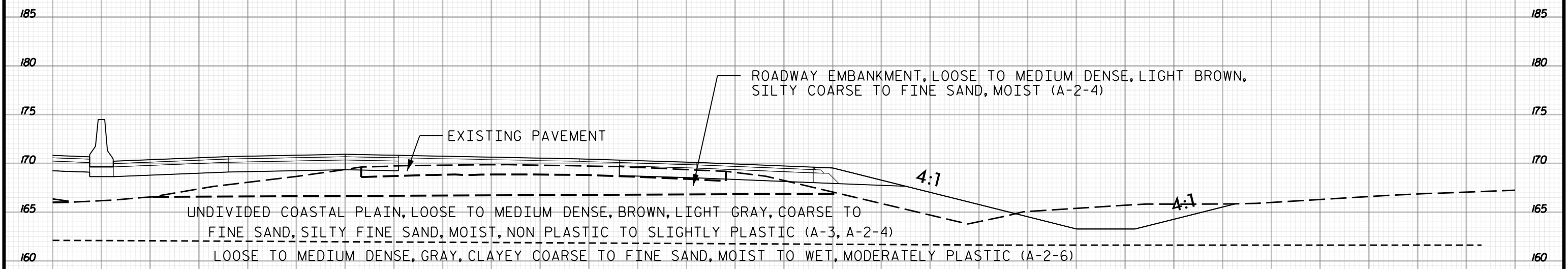

474+50

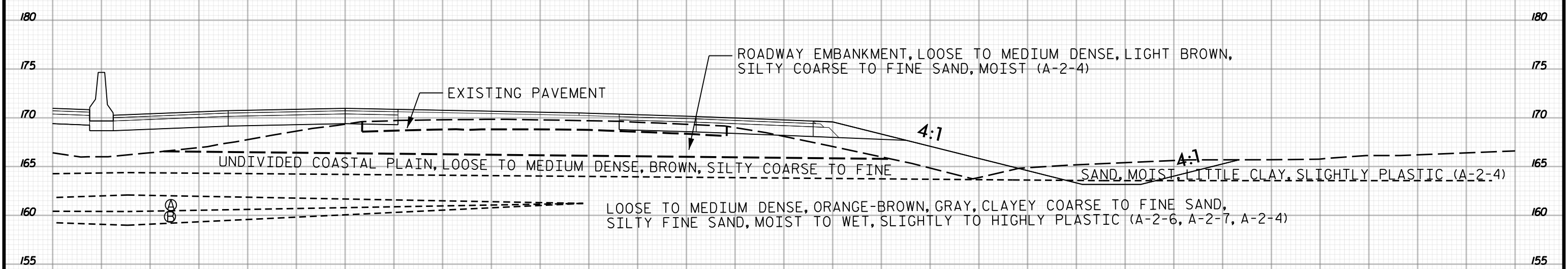

- Ⓐ UNDIVIDED COASTAL PLAIN, SOFT TO MEDIUM STIFF, TAN, FINE SANDY SILT, MOIST (A-4)
- Ⓑ UNDIVIDED COASTAL PLAIN, SOFT TO MEDIUM STIFF, TAN, SILTY CLAY, MOIST, HIGHLY PLASTIC (A-7-6)

474+00  
2 OF 2

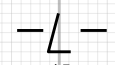

5 0 5 10 15 20 25 30 35 40 45 50 55 60 65 70 75 80 85 90 95 100 105 110 115 120 125 130 135 140 145

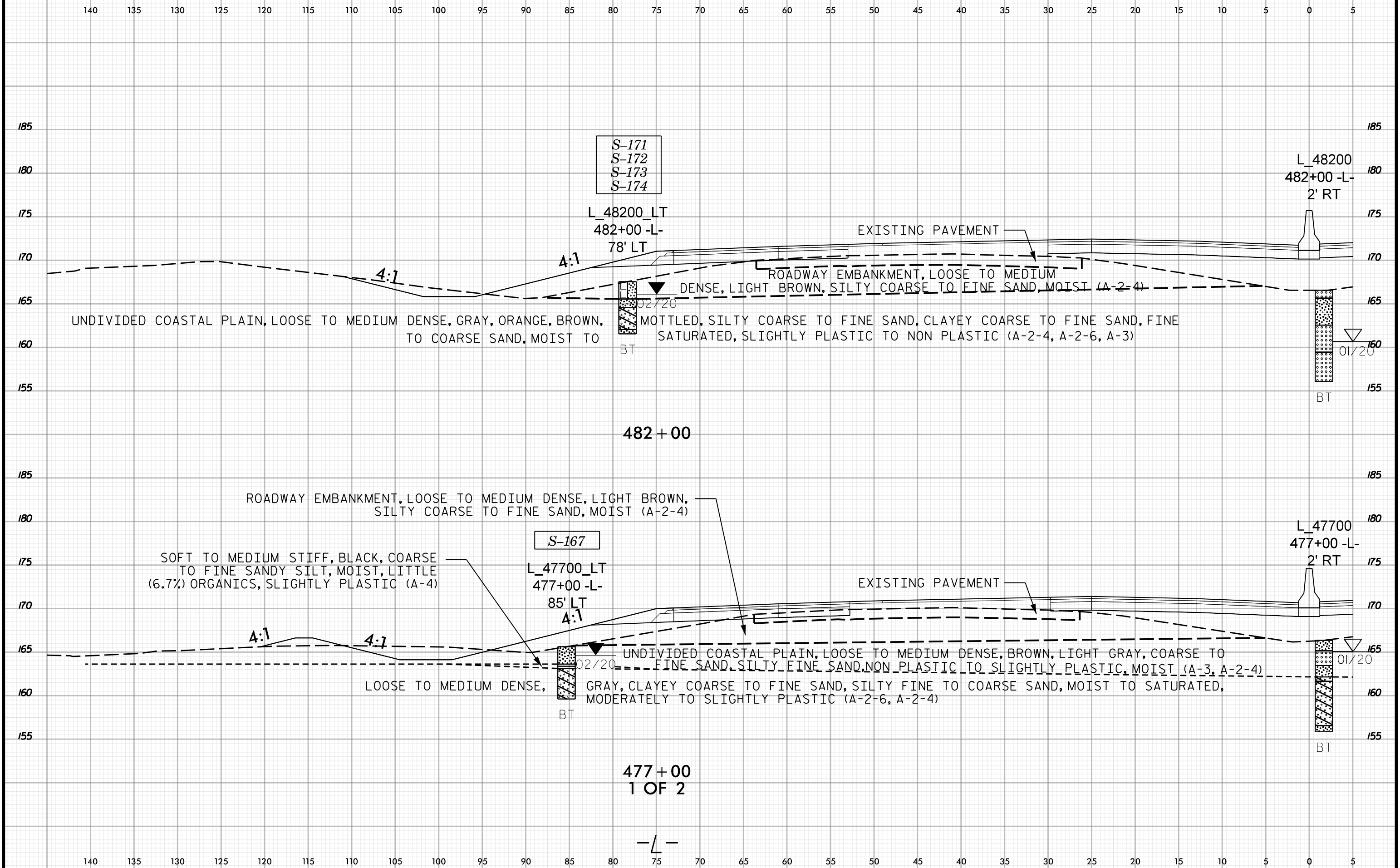

477+00  
1 OF 2

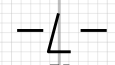

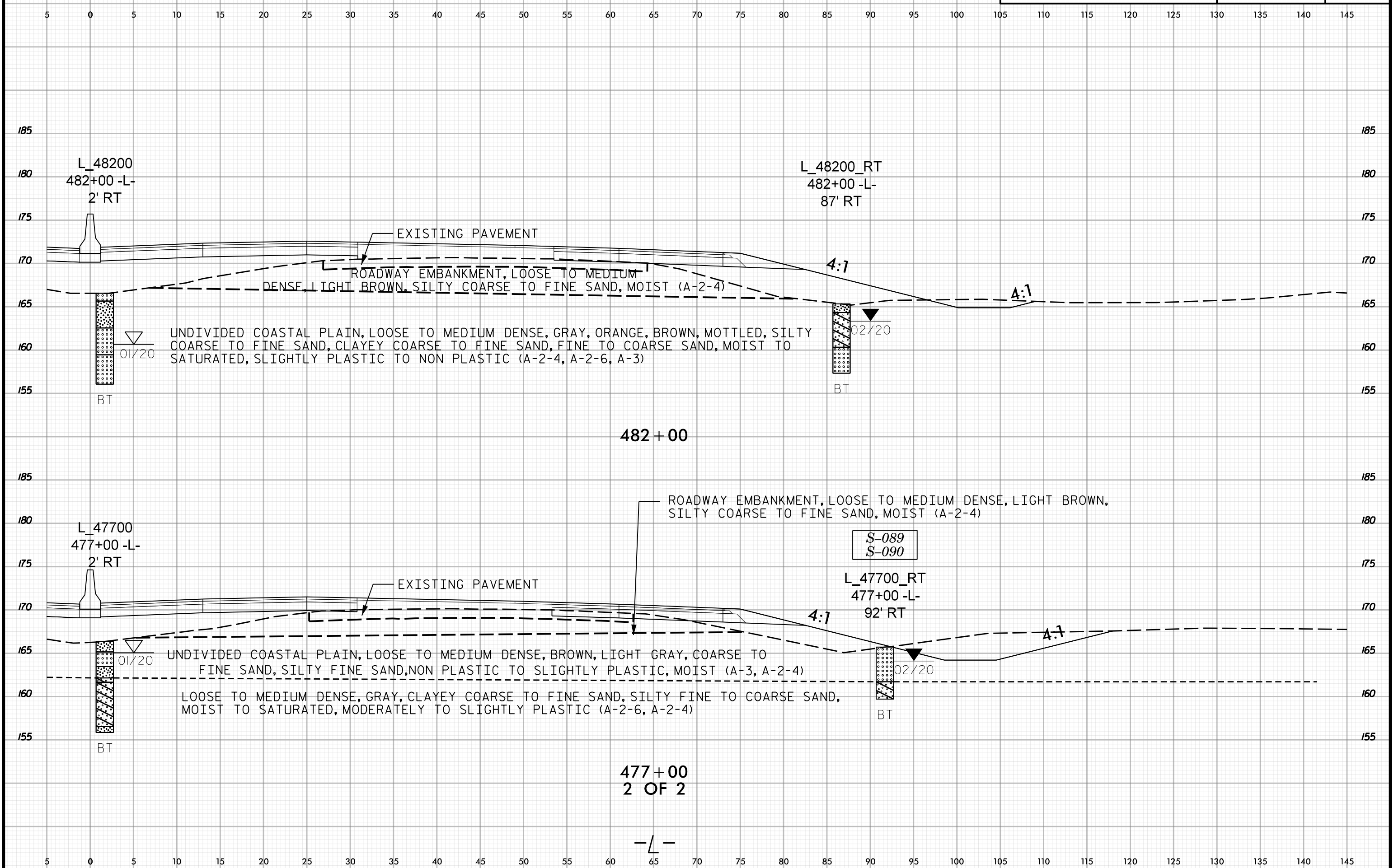
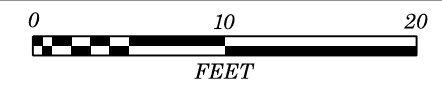



140 135 130 125 120 115 110 105 100 95 90 85 80 75 70 65 60 55 50 45 40 35 30 25 20 15 10 5 0 5

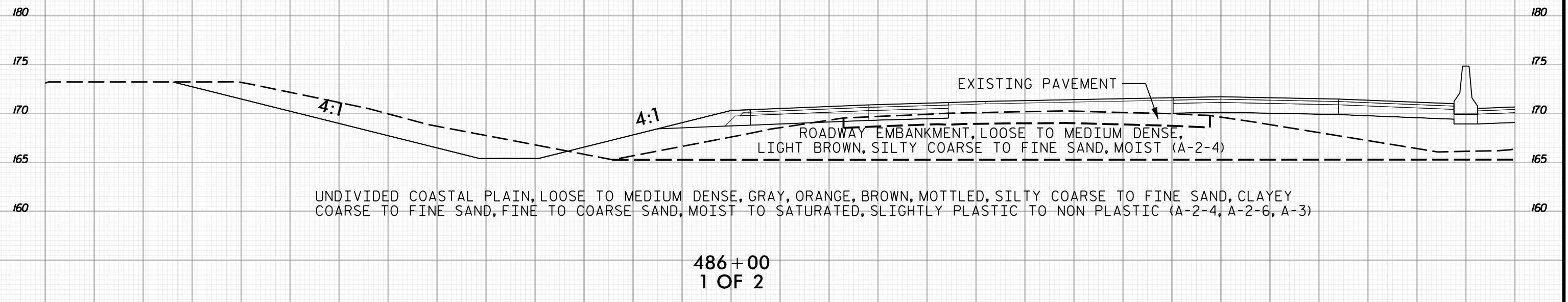
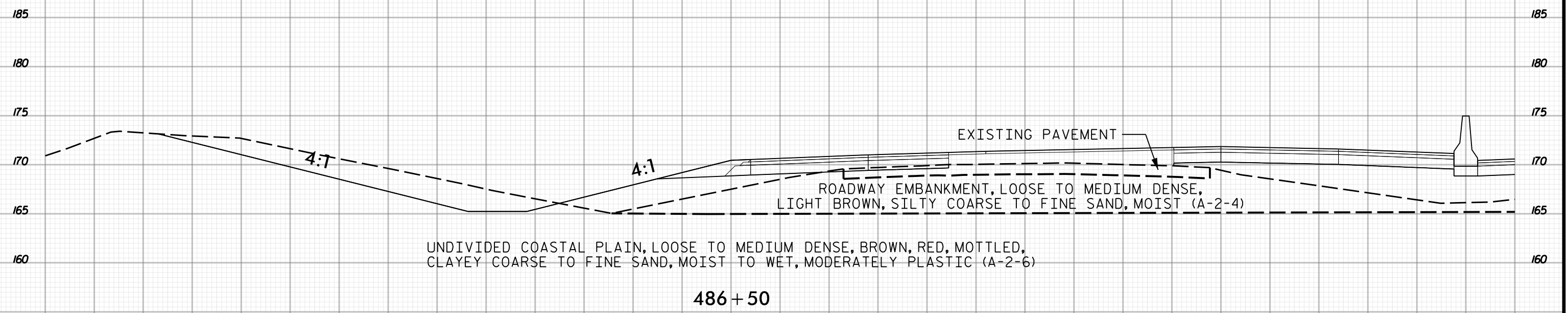

140 135 130 125 120 115 110 105 100 95 90 85 80 75 70 65 60 55 50 45 40 35 30 25 20 15 10 5 0 5

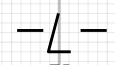



5 0 5 10 15 20 25 30 35 40 45 50 55 60 65 70 75 80 85 90 95 100 105 110 115 120 125 130 135 140 145

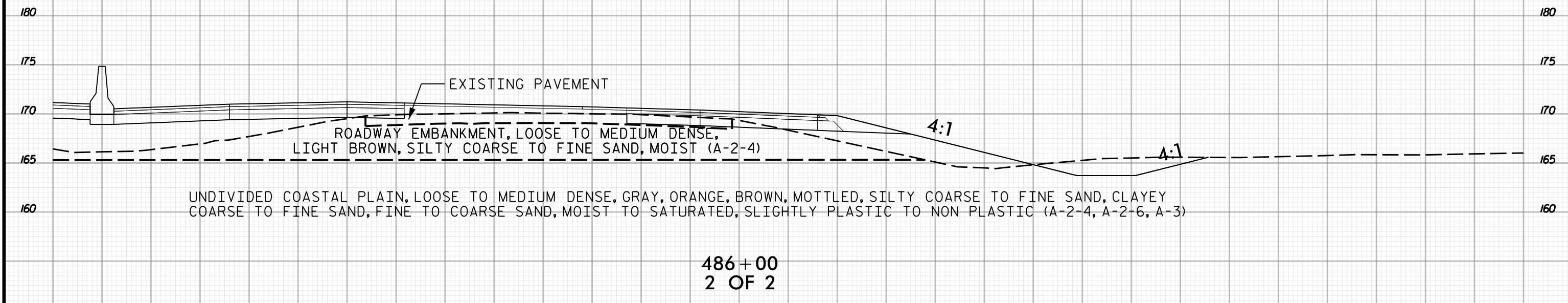
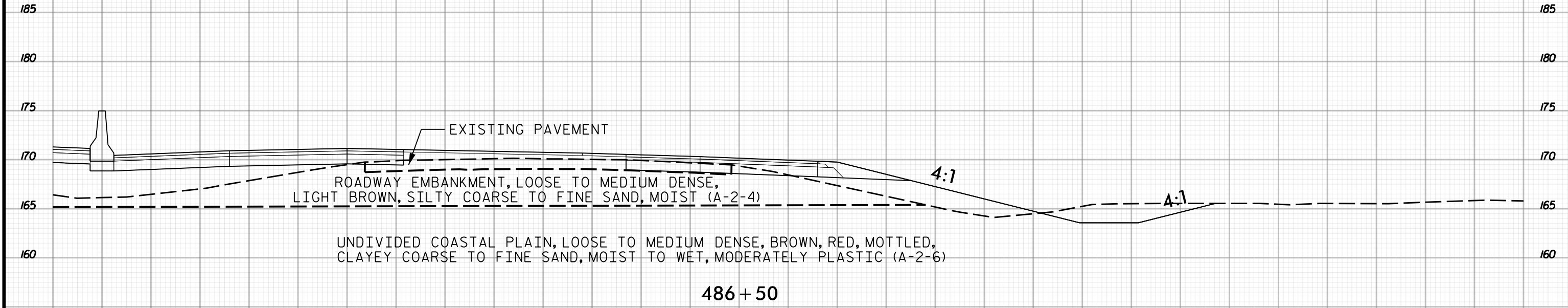

5 0 5 10 15 20 25 30 35 40 45 50 55 60 65 70 75 80 85 90 95 100 105 110 115 120 125 130 135 140 145

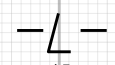





140 135 130 125 120 115 110 105 100 95 90 85 80 75 70 65 60 55 50 45 40 35 30 25 20 15 10 5 0 5

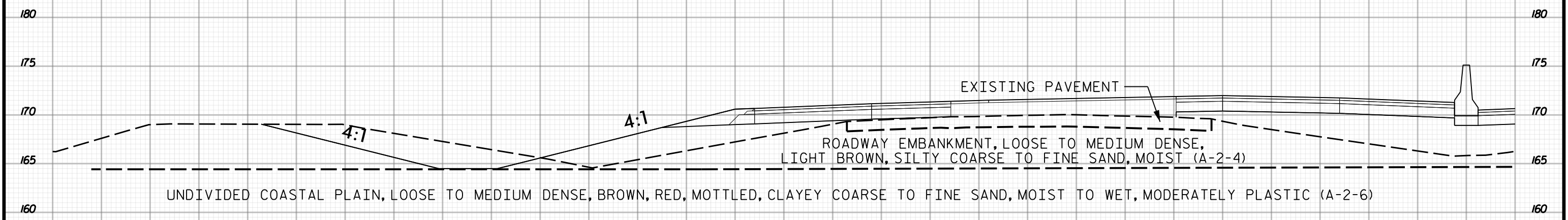

487+50

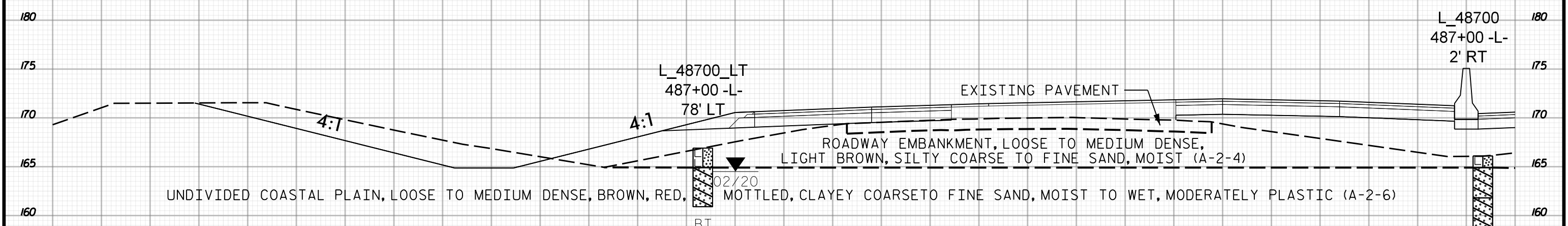

487+00  
1 OF 2

140 135 130 125 120 115 110 105 100 95 90 85 80 75 70 65 60 55 50 45 40 35 30 25 20 15 10 5 0 5



5 0 5 10 15 20 25 30 35 40 45 50 55 60 65 70 75 80 85 90 95 100 105 110 115 120 125 130 135 140 145

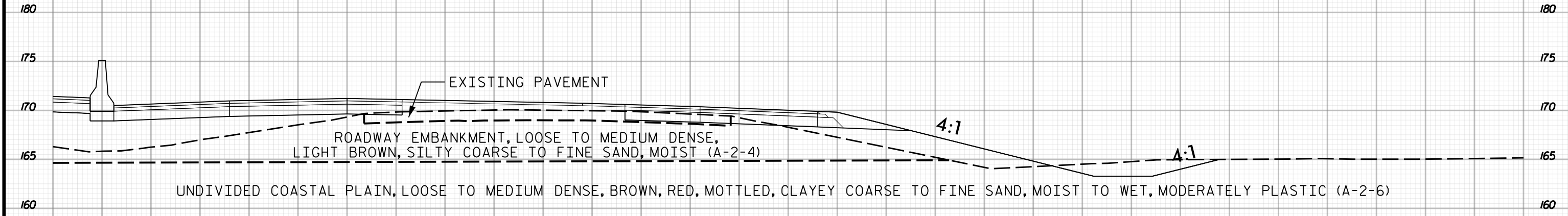

487+50

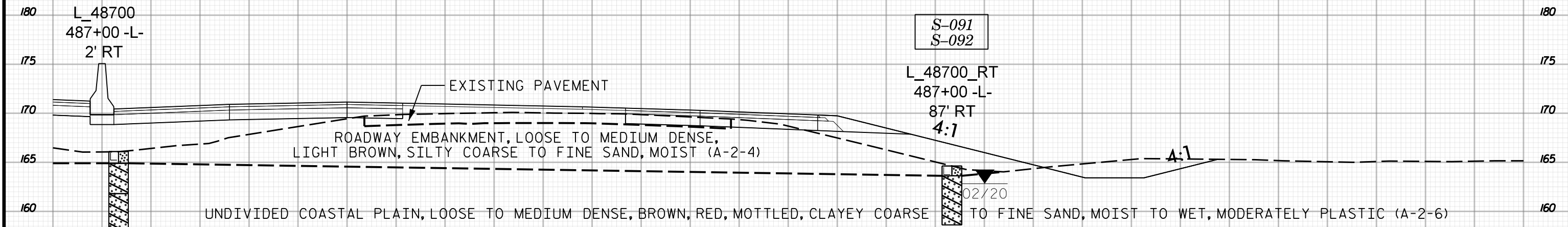

487+00  
2 OF 2

5 0 5 10 15 20 25 30 35 40 45 50 55 60 65 70 75 80 85 90 95 100 105 110 115 120 125 130 135 140 145

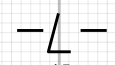

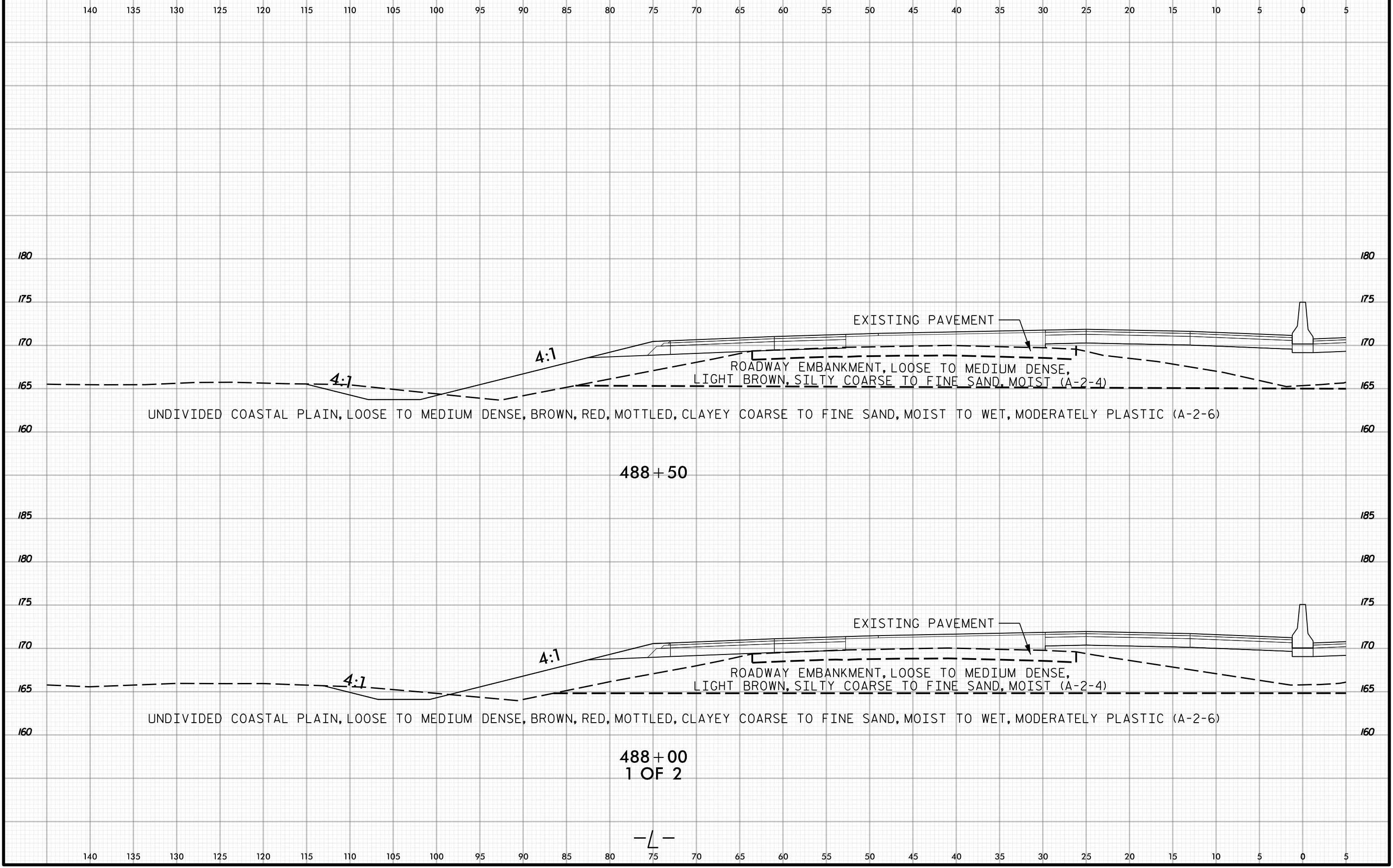
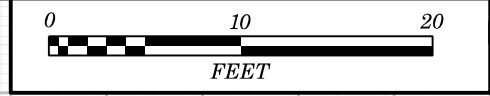

488+50

488+00  
1 OF 2

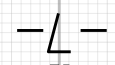



5 0 5 10 15 20 25 30 35 40 45 50 55 60 65 70 75 80 85 90 95 100 105 110 115 120 125 130 135 140 145

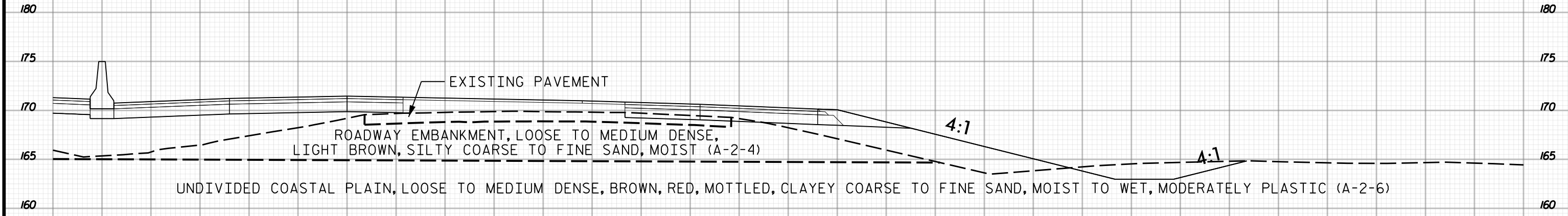

EXISTING PAVEMENT

ROADWAY EMBANKMENT, LOOSE TO MEDIUM DENSE,  
LIGHT BROWN, SILTY COARSE TO FINE SAND, MOIST (A-2-4)

UNDIVIDED COASTAL PLAIN, LOOSE TO MEDIUM DENSE, BROWN, RED, MOTTLED, CLAYEY COARSE TO FINE SAND, MOIST TO WET, MODERATELY PLASTIC (A-2-6)

4:1

1:1

488 + 50

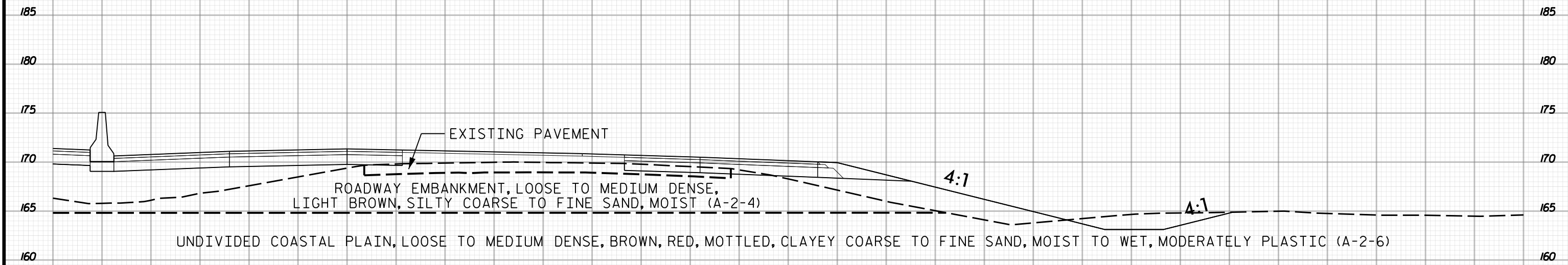

EXISTING PAVEMENT

ROADWAY EMBANKMENT, LOOSE TO MEDIUM DENSE,  
LIGHT BROWN, SILTY COARSE TO FINE SAND, MOIST (A-2-4)

UNDIVIDED COASTAL PLAIN, LOOSE TO MEDIUM DENSE, BROWN, RED, MOTTLED, CLAYEY COARSE TO FINE SAND, MOIST TO WET, MODERATELY PLASTIC (A-2-6)

4:1

1:1

488 + 00  
2 OF 2

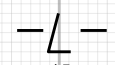

5 0 5 10 15 20 25 30 35 40 45 50 55 60 65 70 75 80 85 90 95 100 105 110 115 120 125 130 135 140 145



PROJ. REFERENCE NO.	SHEET NO.
I-5987A	890

140 135 130 125 120 115 110 105 100 95 90 85 80 75 70 65 60 55 50 45 40 35 30 25 20 15 10 5 0 5

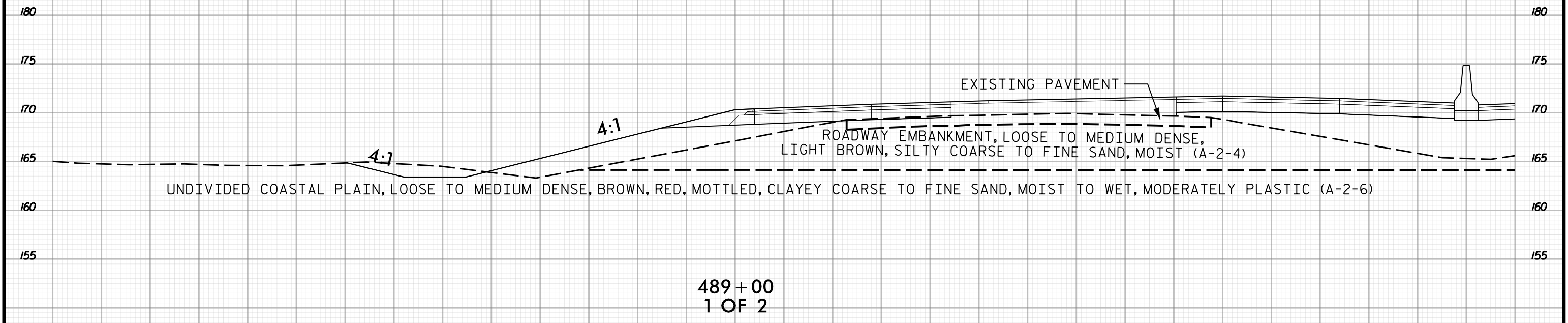
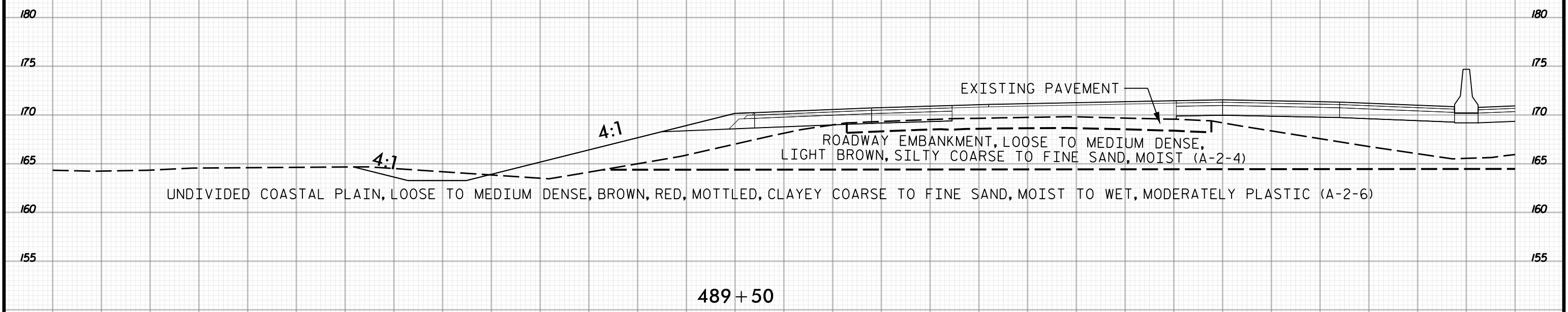

140 135 130 125 120 115 110 105 100 95 90 85 80 75 70 65 60 55 50 45 40 35 30 25 20 15 10 5 0 5



PROJ. REFERENCE NO.	SHEET NO.
I-5987A	891

5 0 5 10 15 20 25 30 35 40 45 50 55 60 65 70 75 80 85 90 95 100 105 110 115 120 125 130 135 140 145

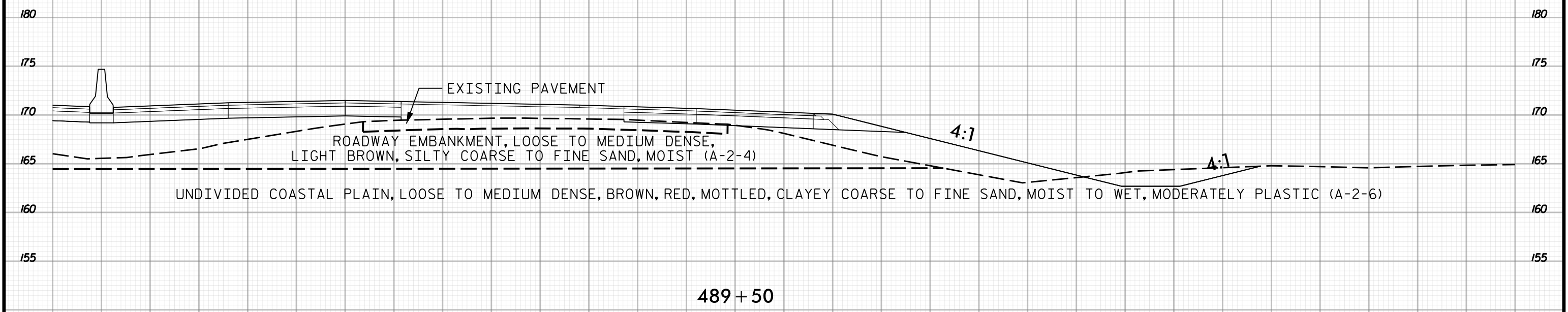

489 + 50

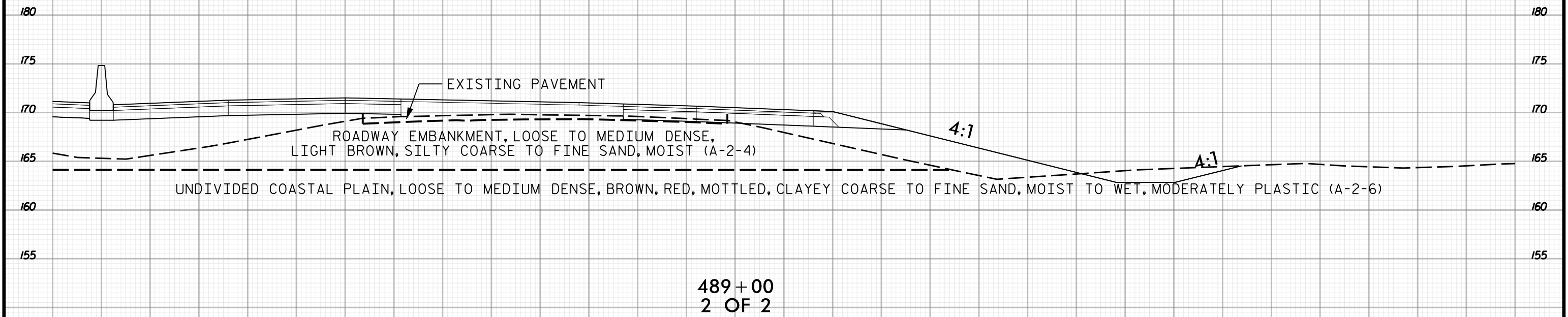

489 + 00  
2 OF 2

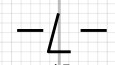

5 0 5 10 15 20 25 30 35 40 45 50 55 60 65 70 75 80 85 90 95 100 105 110 115 120 125 130 135 140 145

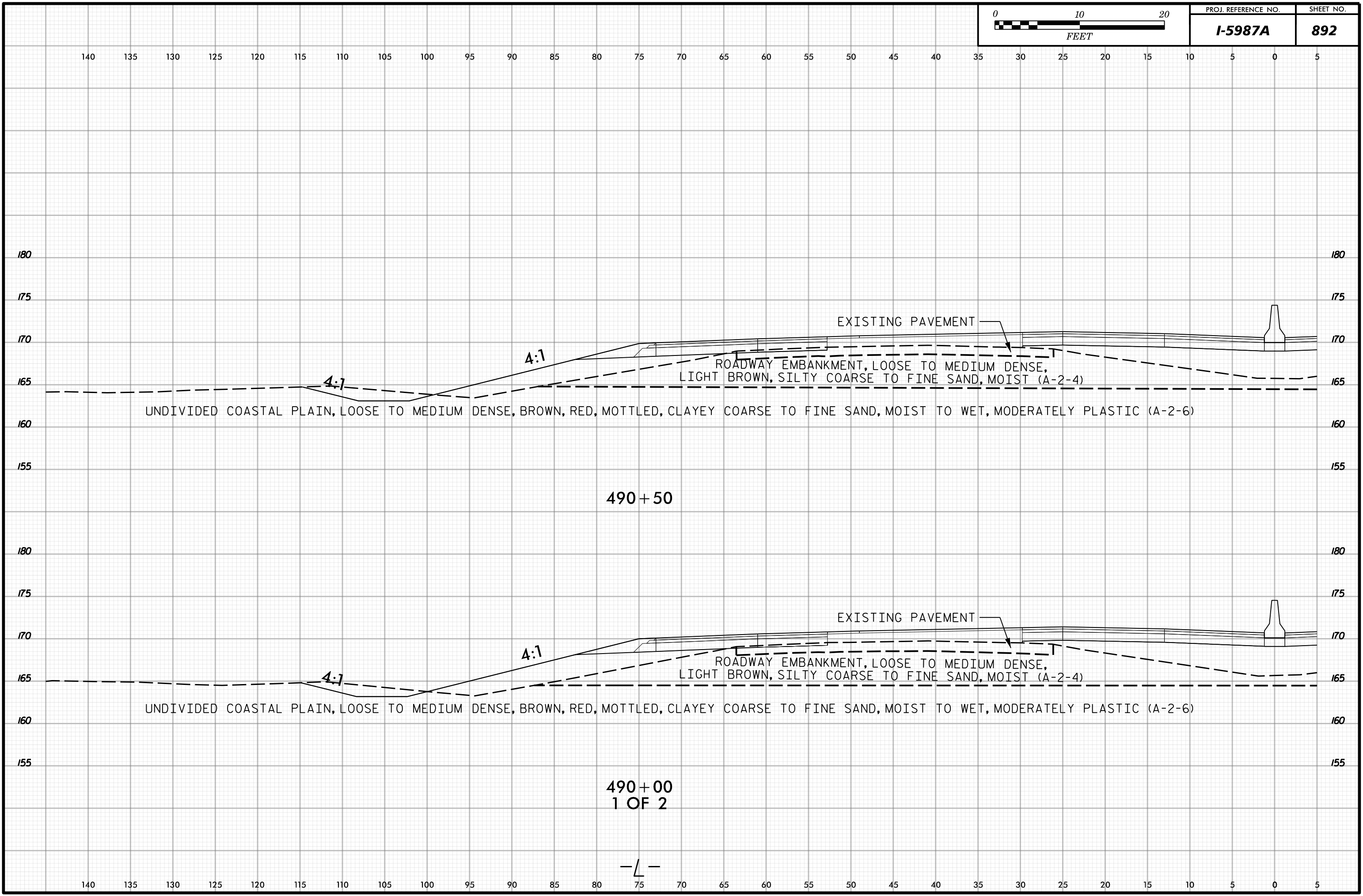

490+50

490+00  
1 OF 2

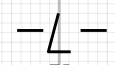



PROJ. REFERENCE NO.	SHEET NO.
I-5987A	893

5 0 5 10 15 20 25 30 35 40 45 50 55 60 65 70 75 80 85 90 95 100 105 110 115 120 125 130 135 140 145

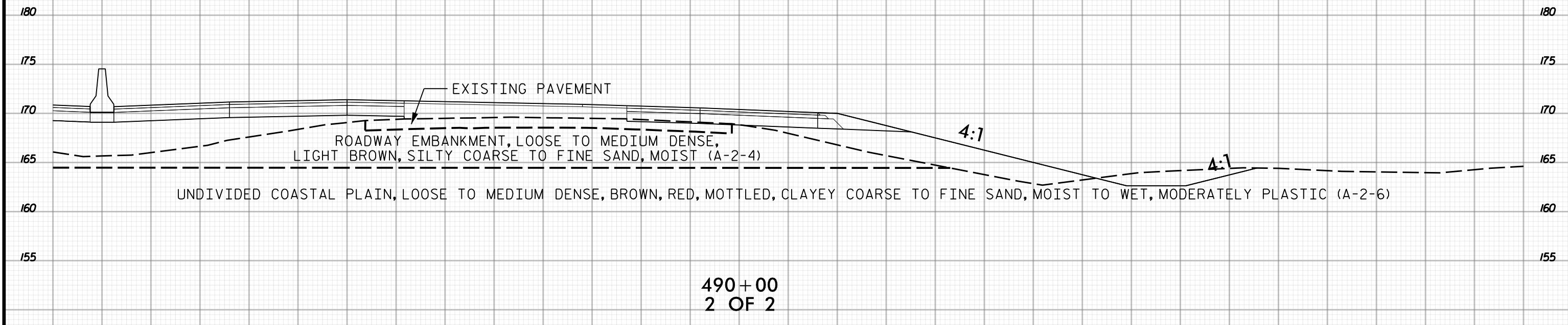
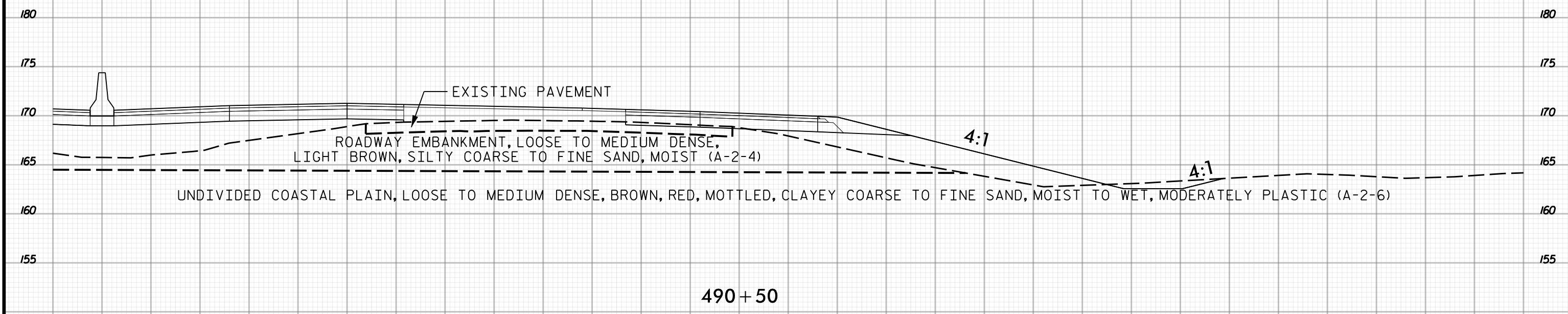

5 0 5 10 15 20 25 30 35 40 45 50 55 60 65 70 75 80 85 90 95 100 105 110 115 120 125 130 135 140 145

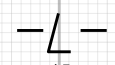





140 135 130 125 120 115 110 105 100 95 90 85 80 75 70 65 60 55 50 45 40 35 30 25 20 15 10 5 0 5

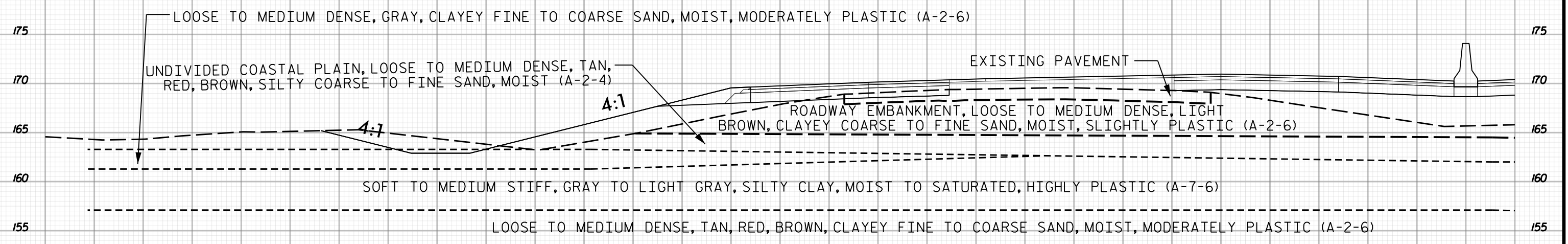

491+50

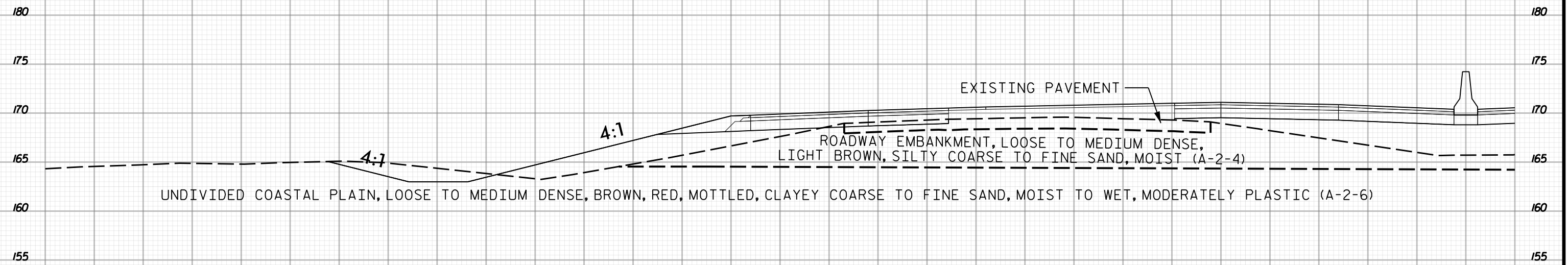

491+00  
1 OF 2

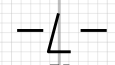

140 135 130 125 120 115 110 105 100 95 90 85 80 75 70 65 60 55 50 45 40 35 30 25 20 15 10 5 0 5



5 0 5 10 15 20 25 30 35 40 45 50 55 60 65 70 75 80 85 90 95 100 105 110 115 120 125 130 135 140 145

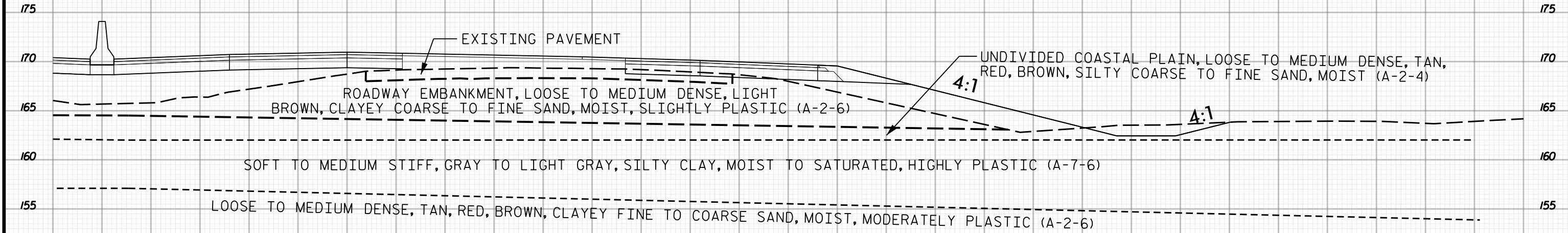

491+50

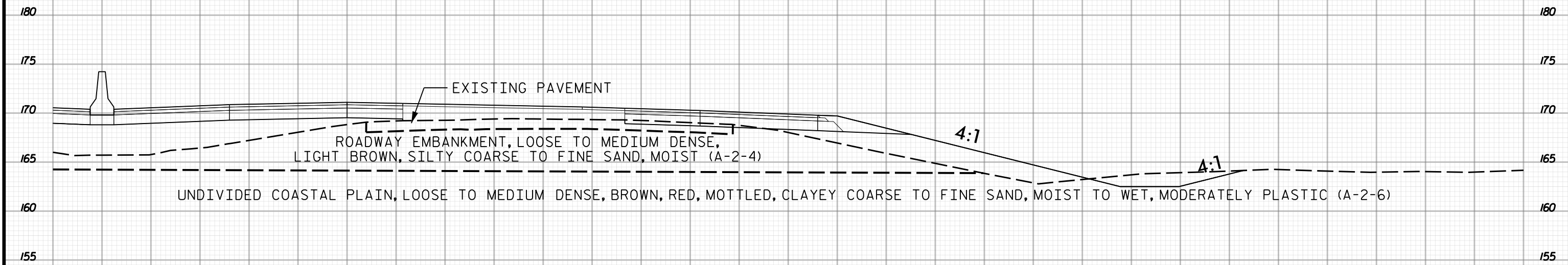

491+00  
2 OF 2



5 0 5 10 15 20 25 30 35 40 45 50 55 60 65 70 75 80 85 90 95 100 105 110 115 120 125 130 135 140 145



140 135 130 125 120 115 110 105 100 95 90 85 80 75 70 65 60 55 50 45 40 35 30 25 20 15 10 5 0 5

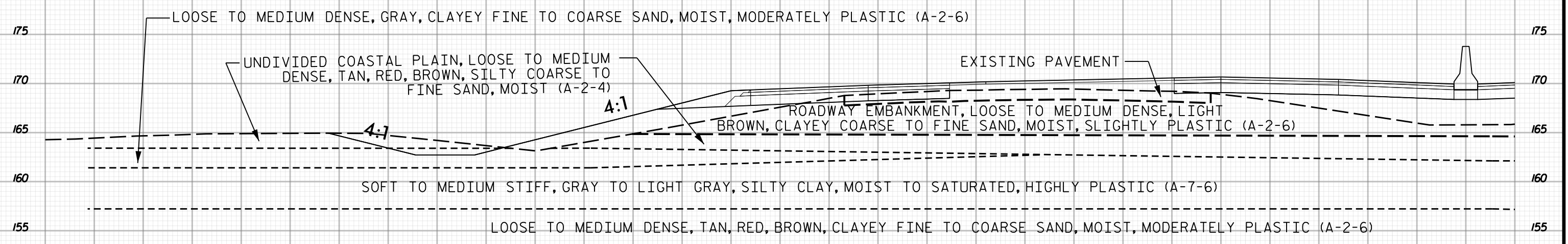

492 + 50

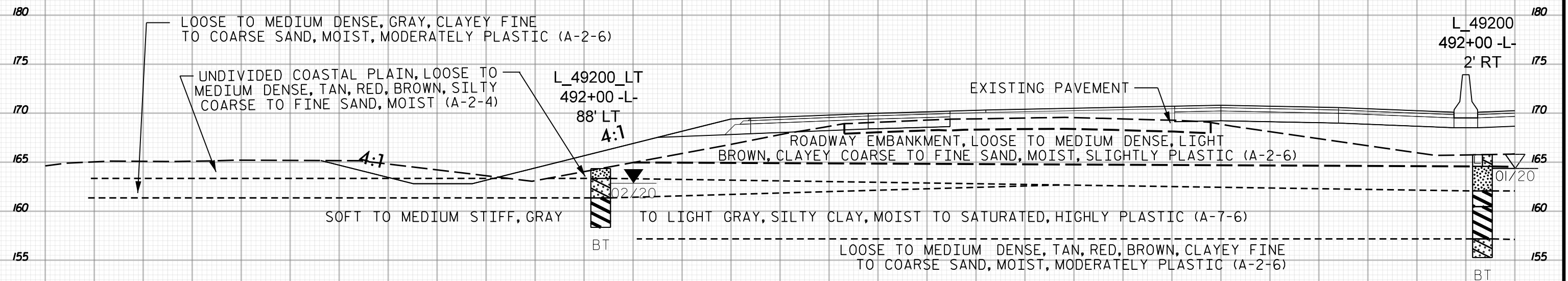

492 + 00  
1 OF 2

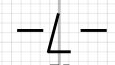

140 135 130 125 120 115 110 105 100 95 90 85 80 75 70 65 60 55 50 45 40 35 30 25 20 15 10 5 0 5

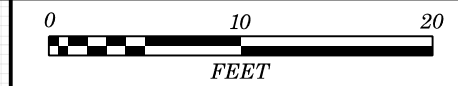

5 0 5 10 15 20 25 30 35 40 45 50 55 60 65 70 75 80 85 90 95 100 105 110 115 120 125 130 135 140 145

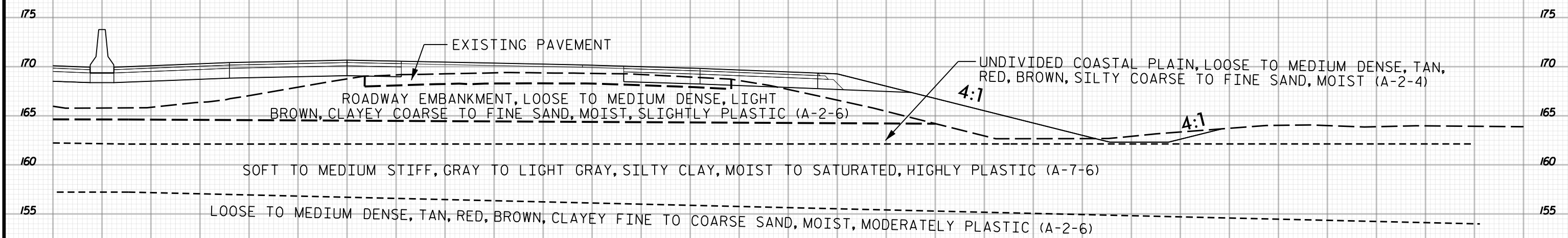

492 + 50

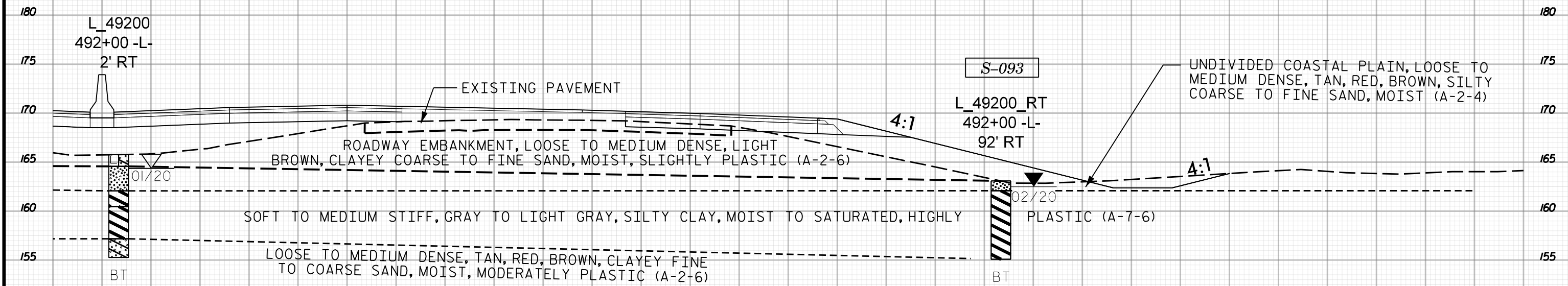

492 + 00  
2 OF 2

5 0 5 10 15 20 25 30 35 40 45 50 55 60 65 70 75 80 85 90 95 100 105 110 115 120 125 130 135 140 145



140 135 130 125 120 115 110 105 100 95 90 85 80 75 70 65 60 55 50 45 40 35 30 25 20 15 10 5 0 5

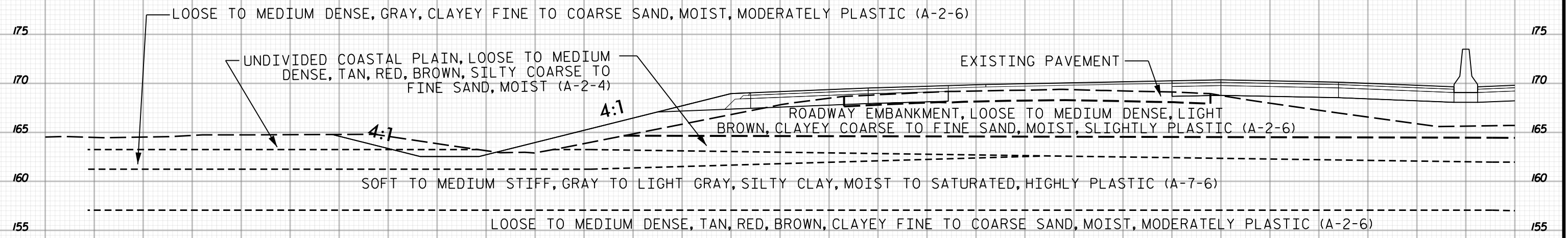

493 + 50

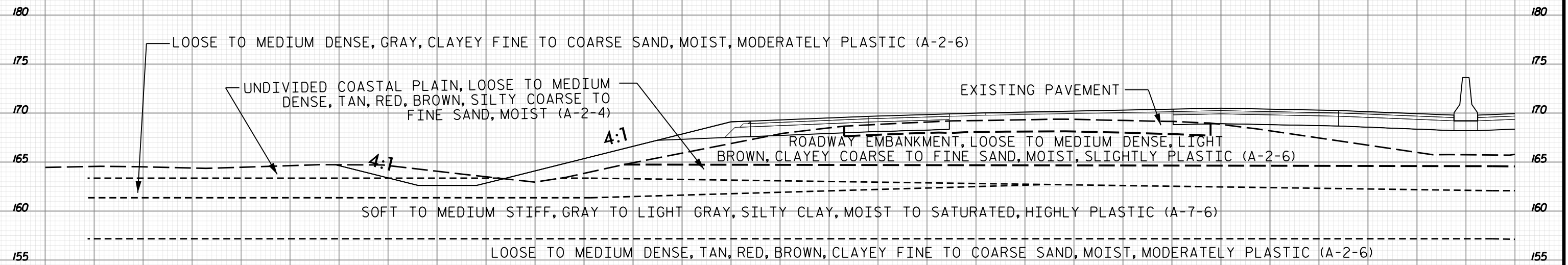

493 + 00  
1 OF 2

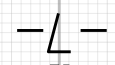

140 135 130 125 120 115 110 105 100 95 90 85 80 75 70 65 60 55 50 45 40 35 30 25 20 15 10 5 0 5



5 0 5 10 15 20 25 30 35 40 45 50 55 60 65 70 75 80 85 90 95 100 105 110 115 120 125 130 135 140 145

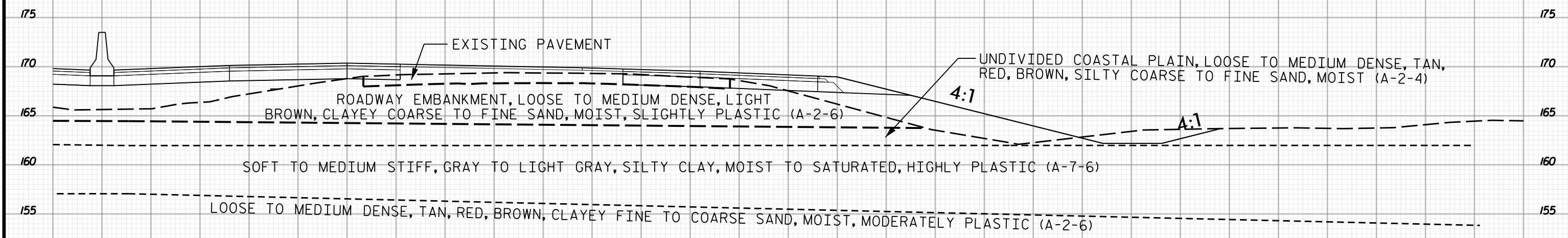

493 + 50

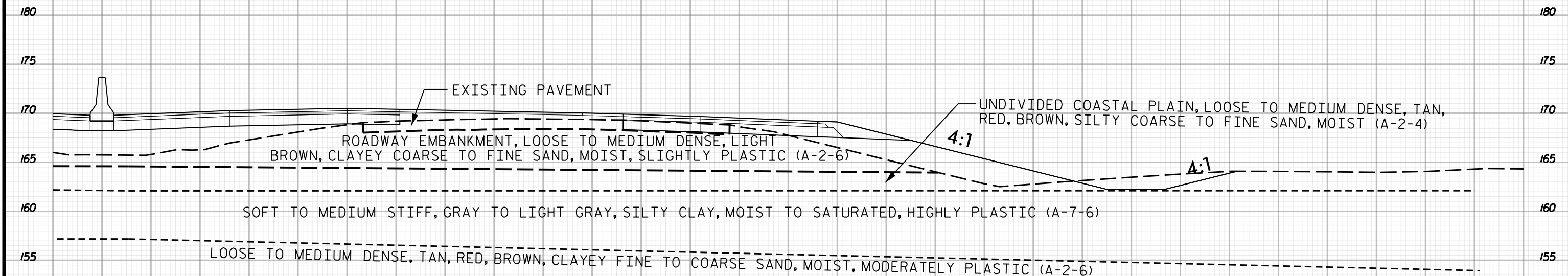

493 + 00  
2 OF 2

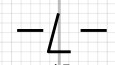

5 0 5 10 15 20 25 30 35 40 45 50 55 60 65 70 75 80 85 90 95 100 105 110 115 120 125 130 135 140 145



140 135 130 125 120 115 110 105 100 95 90 85 80 75 70 65 60 55 50 45 40 35 30 25 20 15 10 5 0 5

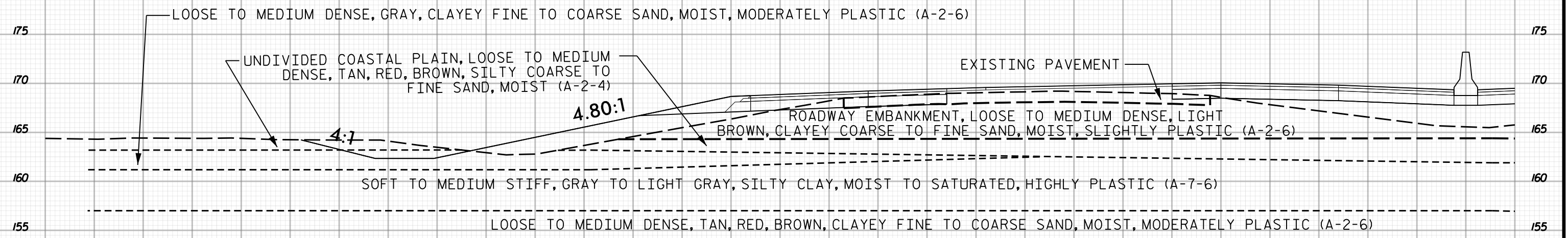

494+50

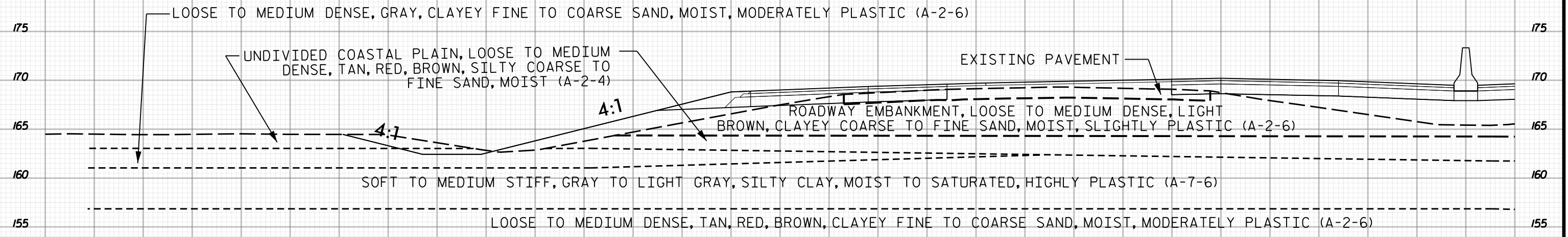

494+00  
1 OF 2

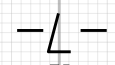

140 135 130 125 120 115 110 105 100 95 90 85 80 75 70 65 60 55 50 45 40 35 30 25 20 15 10 5 0 5



5 0 5 10 15 20 25 30 35 40 45 50 55 60 65 70 75 80 85 90 95 100 105 110 115 120 125 130 135 140 145

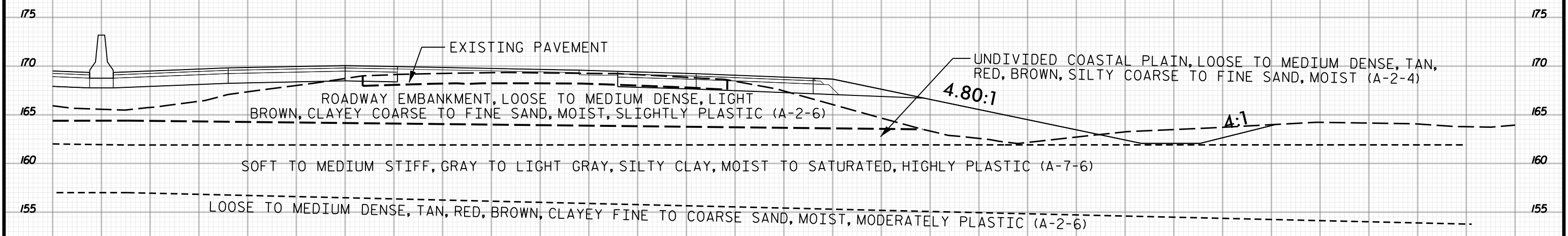

494+50

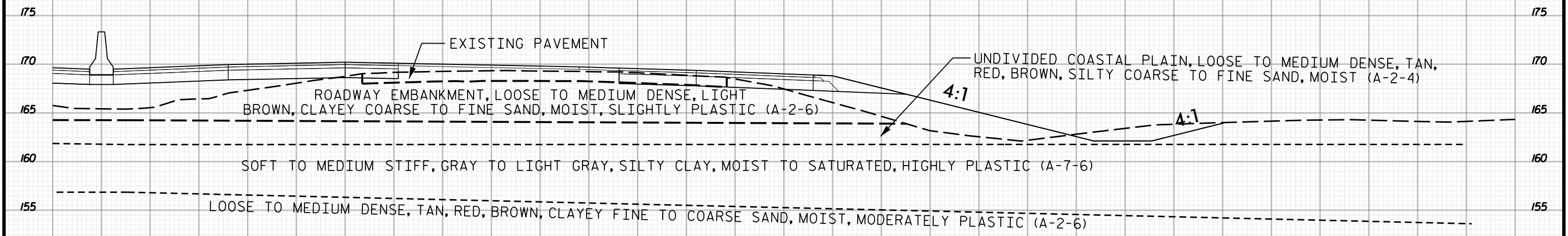

494+00  
2 OF 2

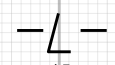

5 0 5 10 15 20 25 30 35 40 45 50 55 60 65 70 75 80 85 90 95 100 105 110 115 120 125 130 135 140 145





140 135 130 125 120 115 110 105 100 95 90 85 80 75 70 65 60 55 50 45 40 35 30 25 20 15 10 5 0 5

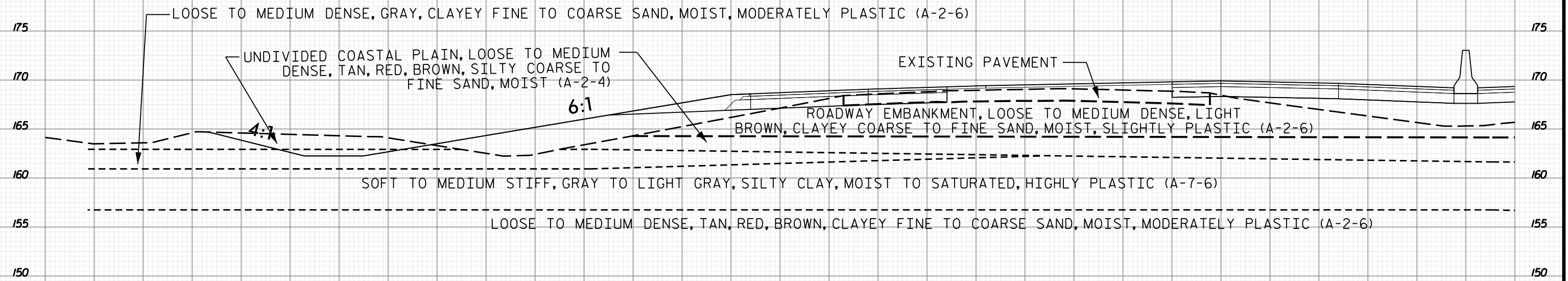

495+00  
1 OF 2

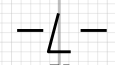

140 135 130 125 120 115 110 105 100 95 90 85 80 75 70 65 60 55 50 45 40 35 30 25 20 15 10 5 0 5



PROJ. REFERENCE NO.	SHEET NO.
I-5987A	903

5 0 5 10 15 20 25 30 35 40 45 50 55 60 65 70 75 80 85 90 95 100 105 110 115 120 125 130 135 140 145

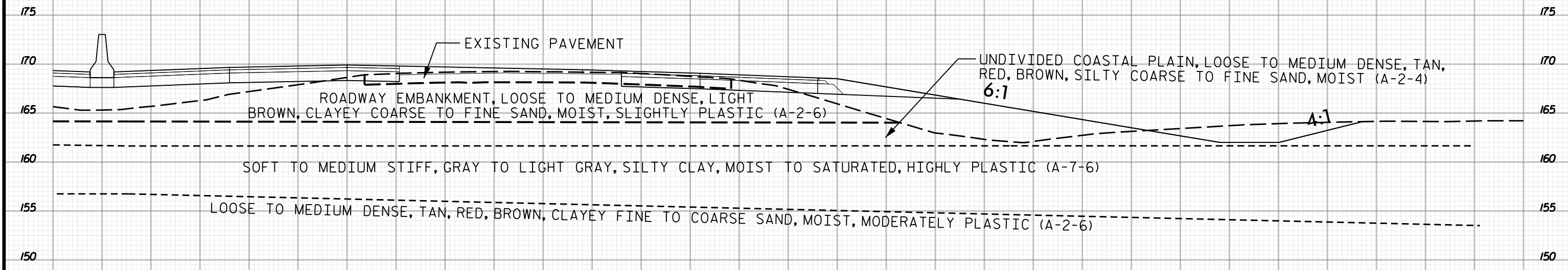

495+00  
2 OF 2

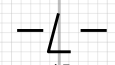

5 0 5 10 15 20 25 30 35 40 45 50 55 60 65 70 75 80 85 90 95 100 105 110 115 120 125 130 135 140 145

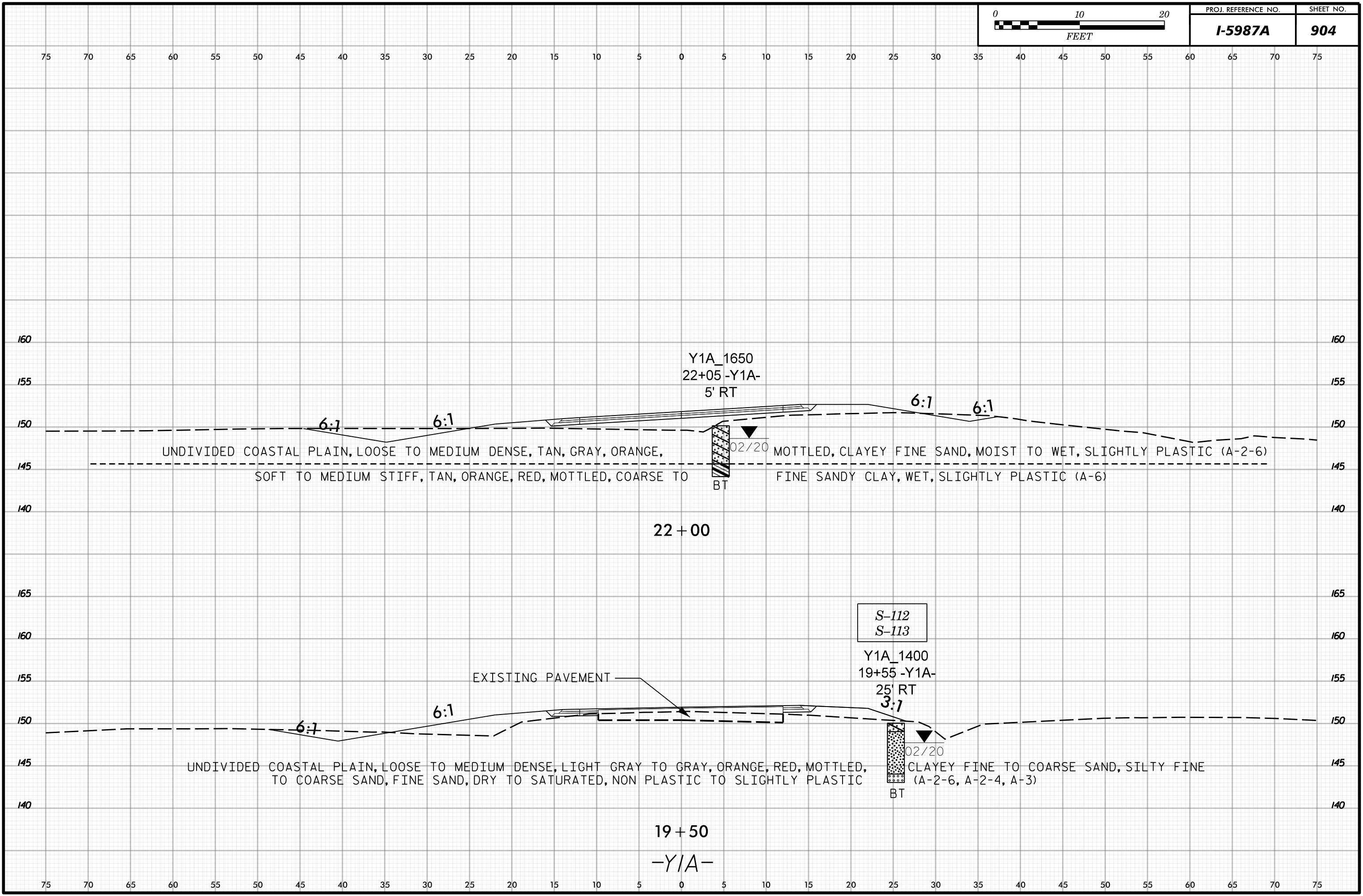

Y1A\_1650  
22+05 -Y1A-  
5' RT

UNDIVIDED COASTAL PLAIN, LOOSE TO MEDIUM DENSE, TAN, GRAY, ORANGE,  
SOFT TO MEDIUM STIFF, TAN, ORANGE, RED, MOTTLED, COARSE TO

MOTTLED, CLAYEY FINE SAND, MOIST TO WET, SLIGHTLY PLASTIC (A-2-6)  
FINE SANDY CLAY, WET, SLIGHTLY PLASTIC (A-6)

22 + 00

S-112  
S-113

Y1A\_1400  
19+55 -Y1A-  
25' RT  
3:7

UNDIVIDED COASTAL PLAIN, LOOSE TO MEDIUM DENSE, LIGHT GRAY TO GRAY, ORANGE, RED, MOTTLED,  
TO COARSE SAND, FINE SAND, DRY TO SATURATED, NON PLASTIC TO SLIGHTLY PLASTIC

CLAYEY FINE TO COARSE SAND, SILTY FINE  
(A-2-6, A-2-4, A-3)

19 + 50  
-Y1A-

EXISTING PAVEMENT

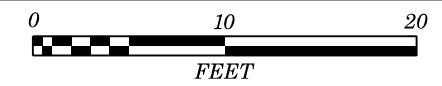

75 70 65 60 55 50 45 40 35 30 25 20 15 10 5 0 5 10 15 20 25 30 35 40 45 50 55 60 65 70 75

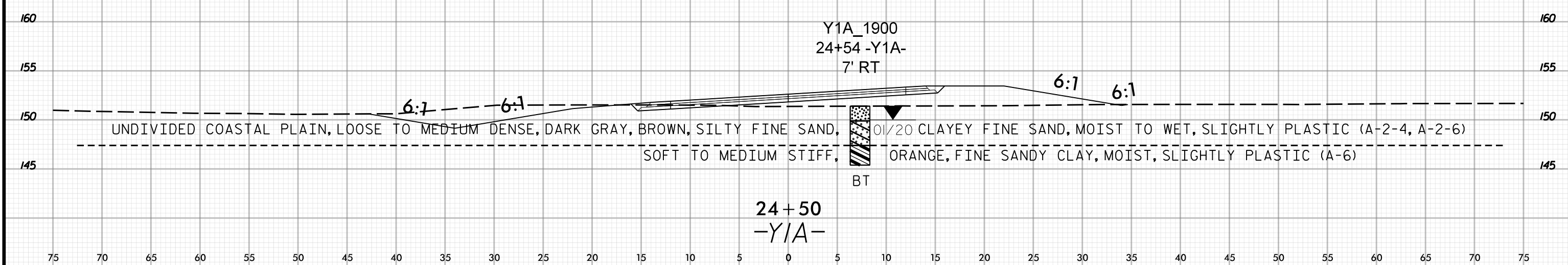
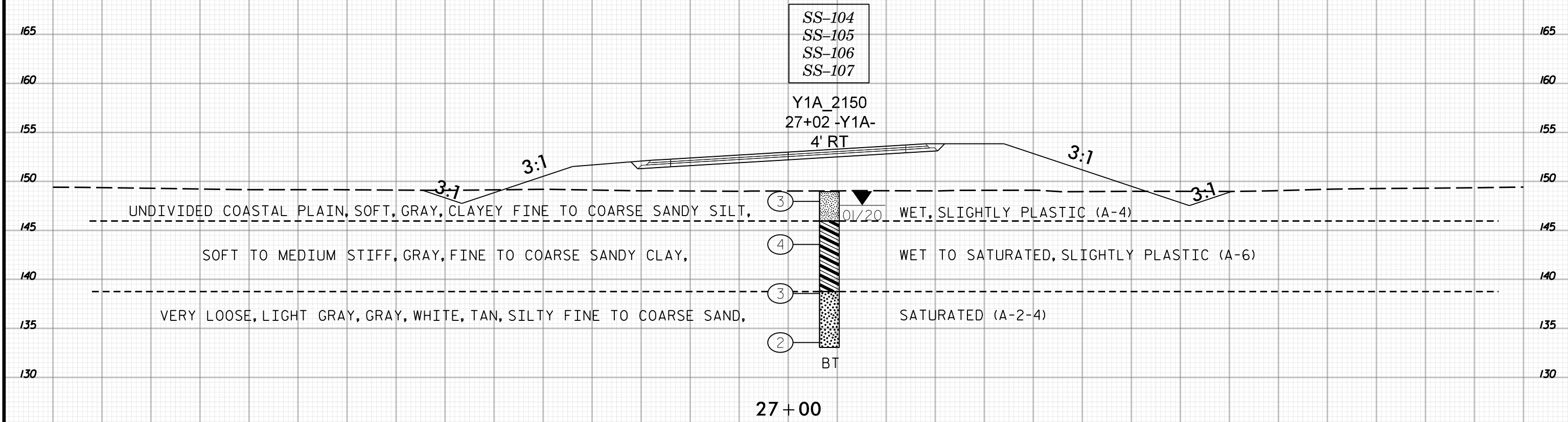

75 70 65 60 55 50 45 40 35 30 25 20 15 10 5 0 5 10 15 20 25 30 35 40 45 50 55 60 65 70 75

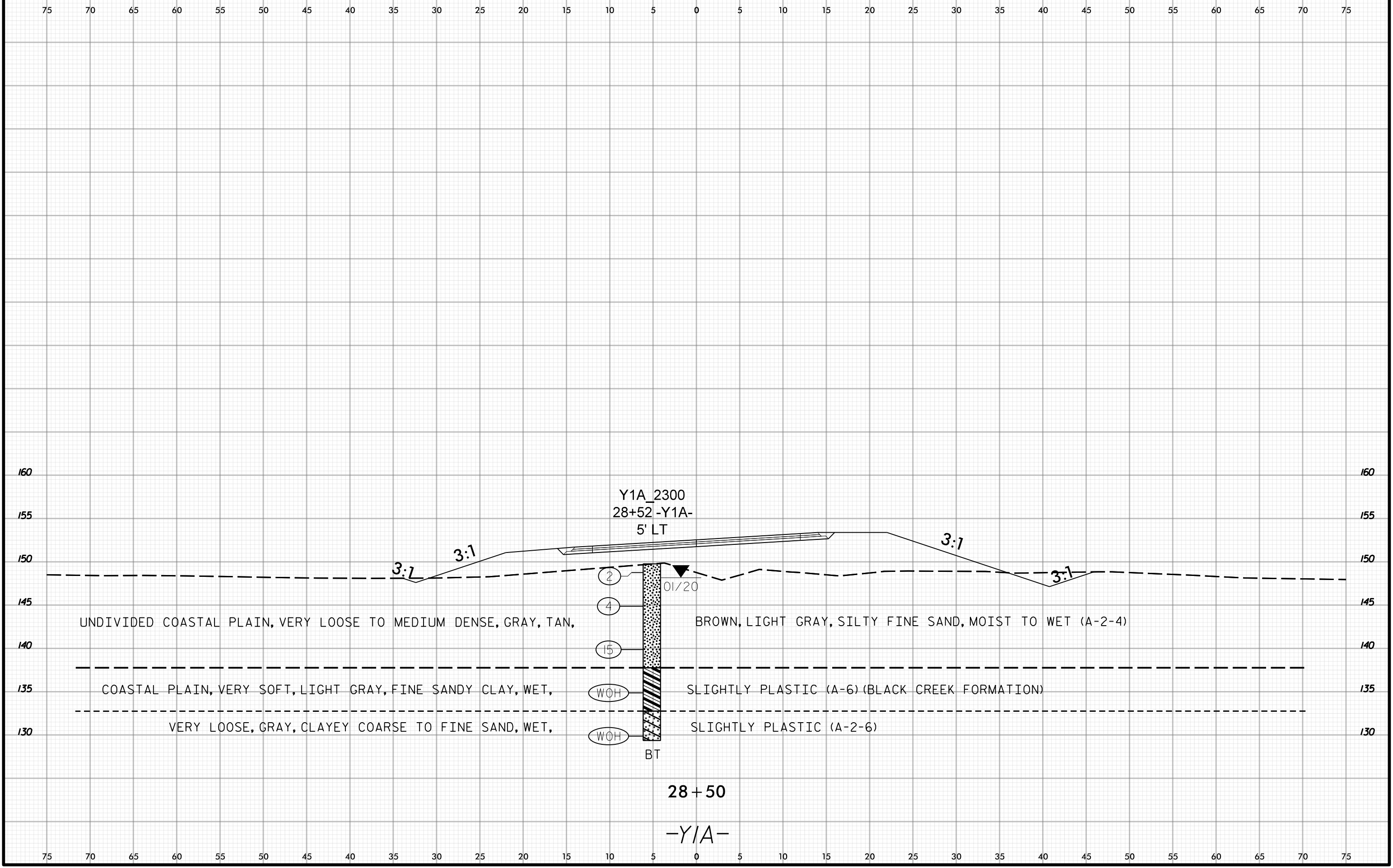
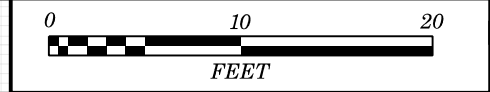

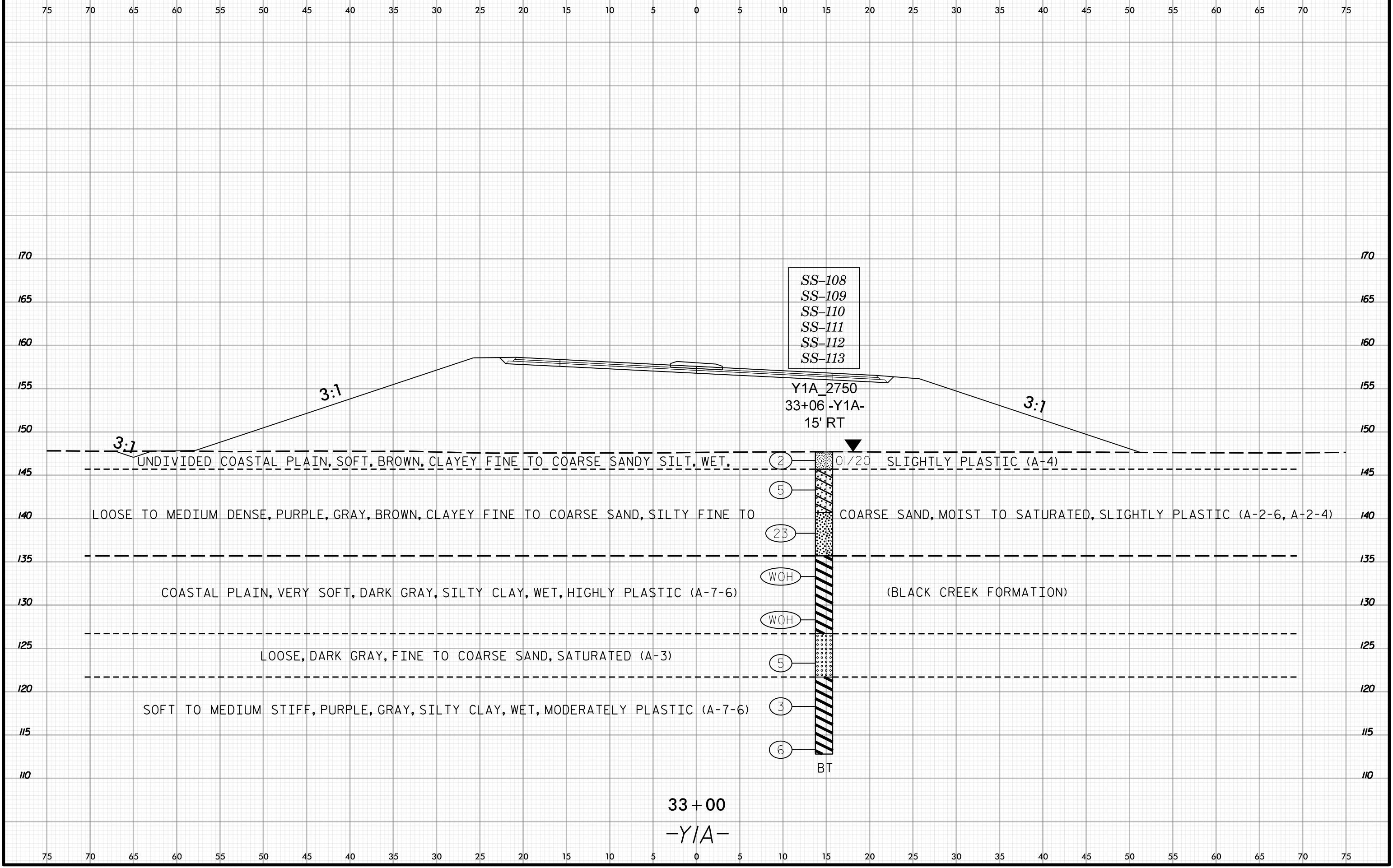

SS-108  
 SS-109  
 SS-110  
 SS-111  
 SS-112  
 SS-113

Y1A 2750  
 33+06 -Y1A-  
 15' RT

3:1

3:1

3:1

UNDIVIDED COASTAL PLAIN, SOFT, BROWN, CLAYEY FINE TO COARSE SANDY SILT, WET,

② 01/20 SLIGHTLY PLASTIC (A-4)

LOOSE TO MEDIUM DENSE, PURPLE, GRAY, BROWN, CLAYEY FINE TO COARSE SAND, SILTY FINE TO

⑤

COARSE SAND, MOIST TO SATURATED, SLIGHTLY PLASTIC (A-2-6, A-2-4)

②3

COASTAL PLAIN, VERY SOFT, DARK GRAY, SILTY CLAY, WET, HIGHLY PLASTIC (A-7-6)

WOH

(BLACK CREEK FORMATION)

WOH

LOOSE, DARK GRAY, FINE TO COARSE SAND, SATURATED (A-3)

⑤

SOFT TO MEDIUM STIFF, PURPLE, GRAY, SILTY CLAY, WET, MODERATELY PLASTIC (A-7-6)

③

⑥

BT

33 + 00  
 -Y1A-

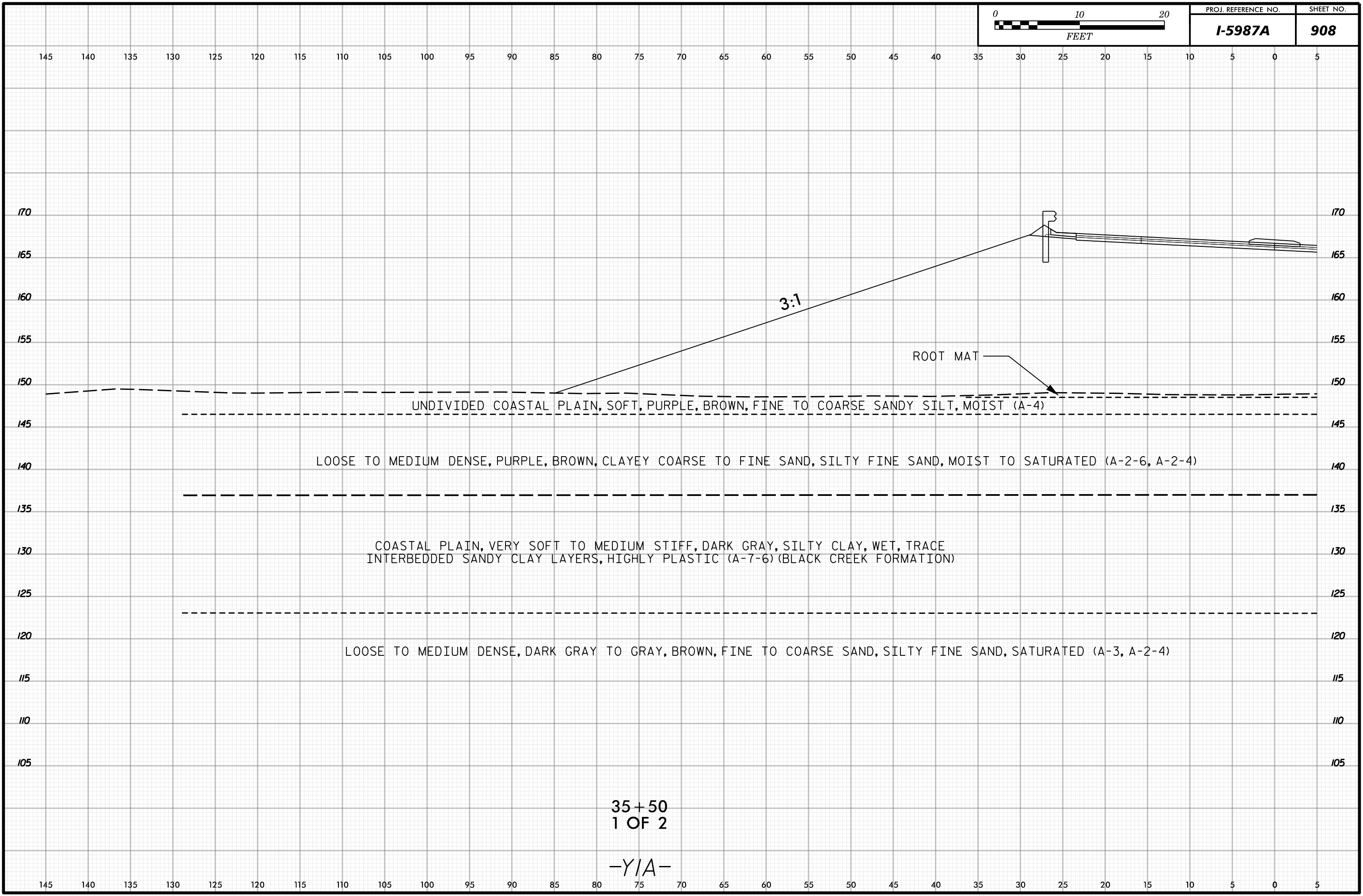

145 140 135 130 125 120 115 110 105 100 95 90 85 80 75 70 65 60 55 50 45 40 35 30 25 20 15 10 5 0 5

170 165 160 155 150 145 140 135 130 125 120 115 110 105 100 95 90 85 80 75 70 65 60 55 50 45 40 35 30 25 20 15 10 5 0 5

3:1

ROOT MAT

UNDIVIDED COASTAL PLAIN, SOFT, PURPLE, BROWN, FINE TO COARSE SANDY SILT, MOIST (A-4)

LOOSE TO MEDIUM DENSE, PURPLE, BROWN, CLAYEY COARSE TO FINE SAND, SILTY FINE SAND, MOIST TO SATURATED (A-2-6, A-2-4)

COASTAL PLAIN, VERY SOFT TO MEDIUM STIFF, DARK GRAY, SILTY CLAY, WET, TRACE INTERBEDDED SANDY CLAY LAYERS, HIGHLY PLASTIC (A-7-6) (BLACK CREEK FORMATION)

LOOSE TO MEDIUM DENSE, DARK GRAY TO GRAY, BROWN, FINE TO COARSE SAND, SILTY FINE SAND, SATURATED (A-3, A-2-4)

35+50  
1 OF 2

-Y/A-

145 140 135 130 125 120 115 110 105 100 95 90 85 80 75 70 65 60 55 50 45 40 35 30 25 20 15 10 5 0 5

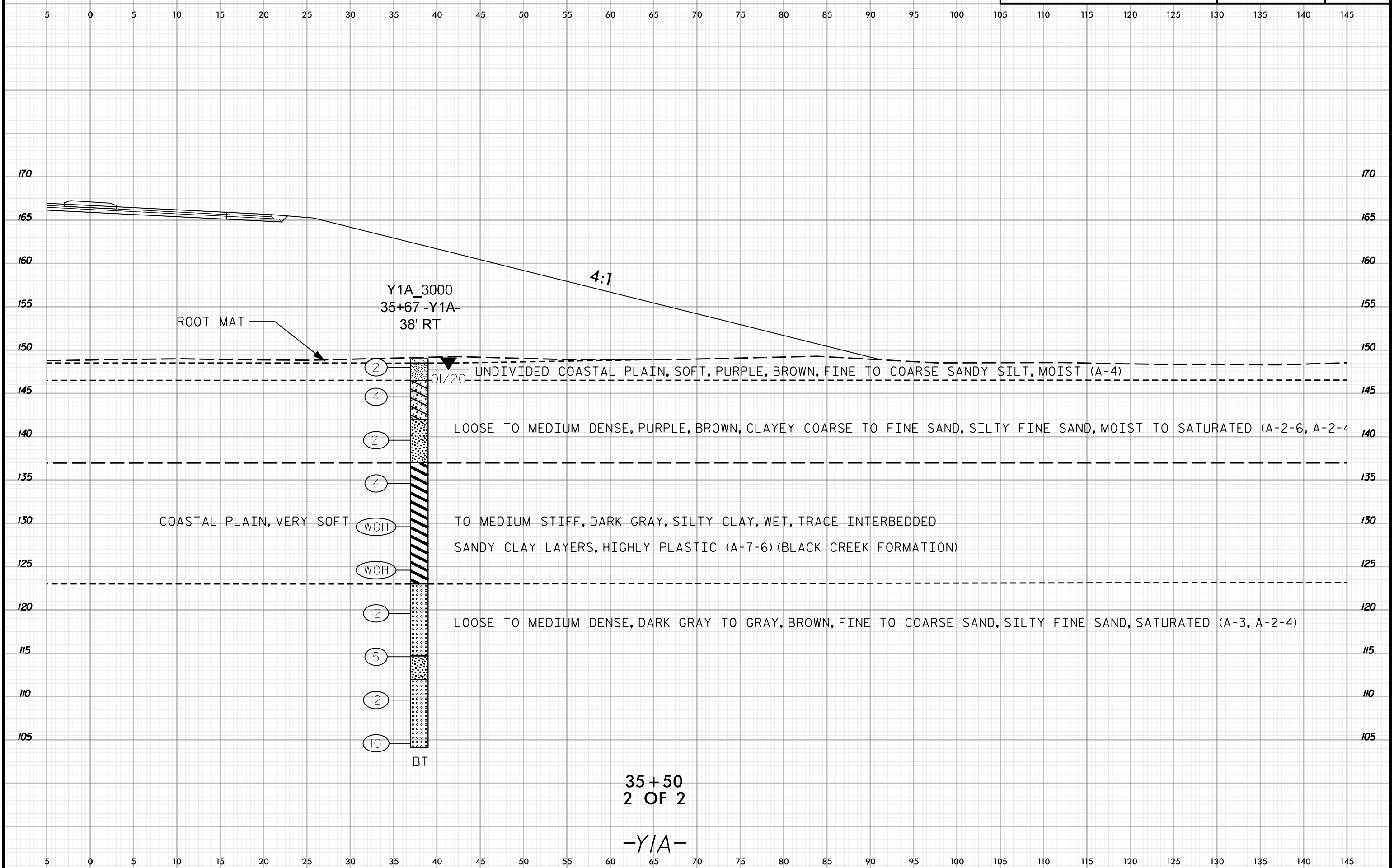

35+50  
2 OF 2

-Y/A-



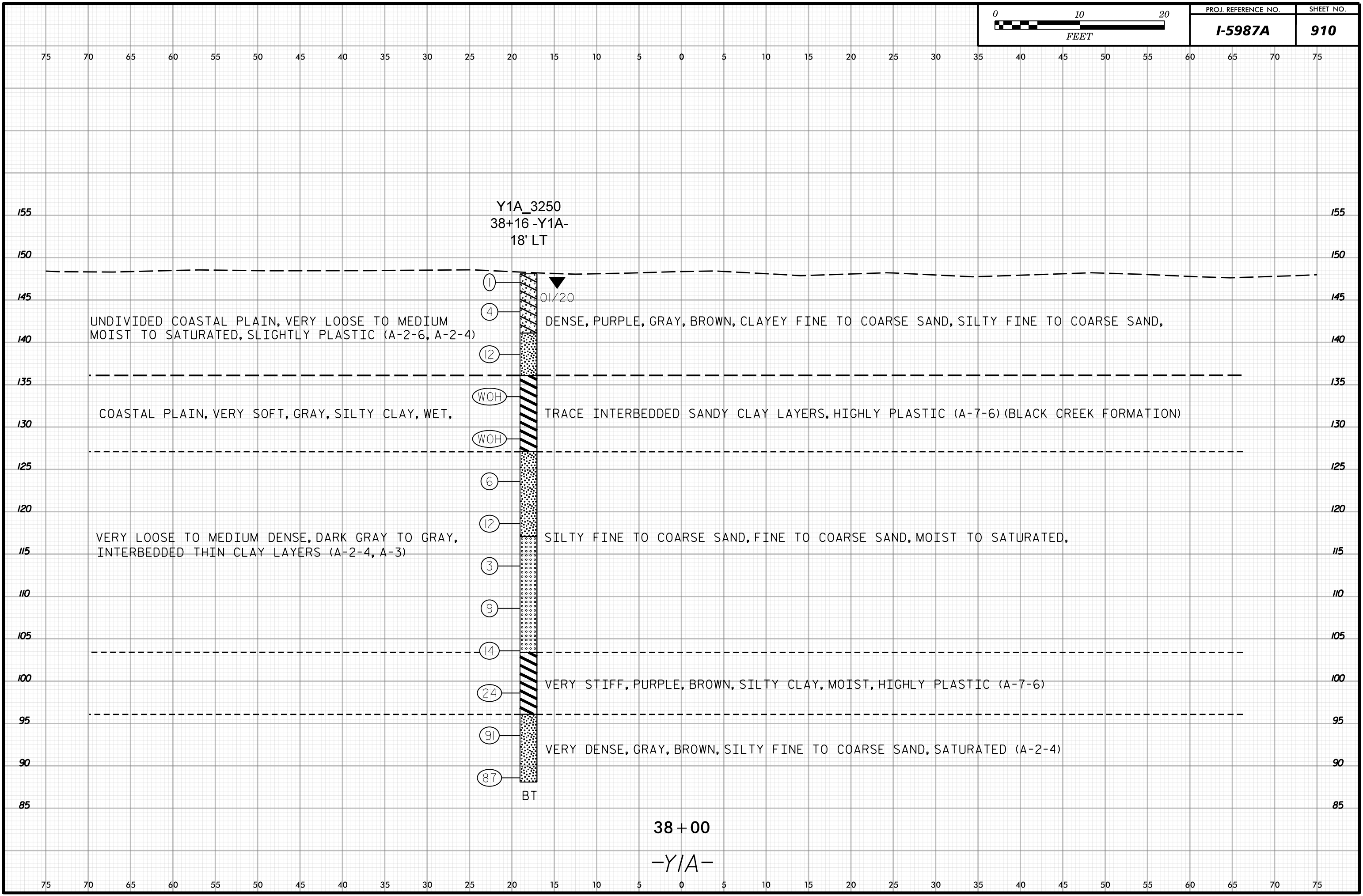
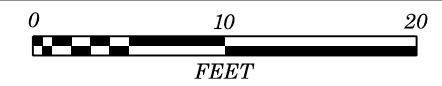

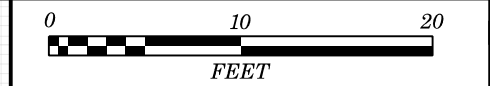

145 140 135 130 125 120 115 110 105 100 95 90 85 80 75 70 65 60 55 50 45 40 35 30 25 20 15 10 5 0 5

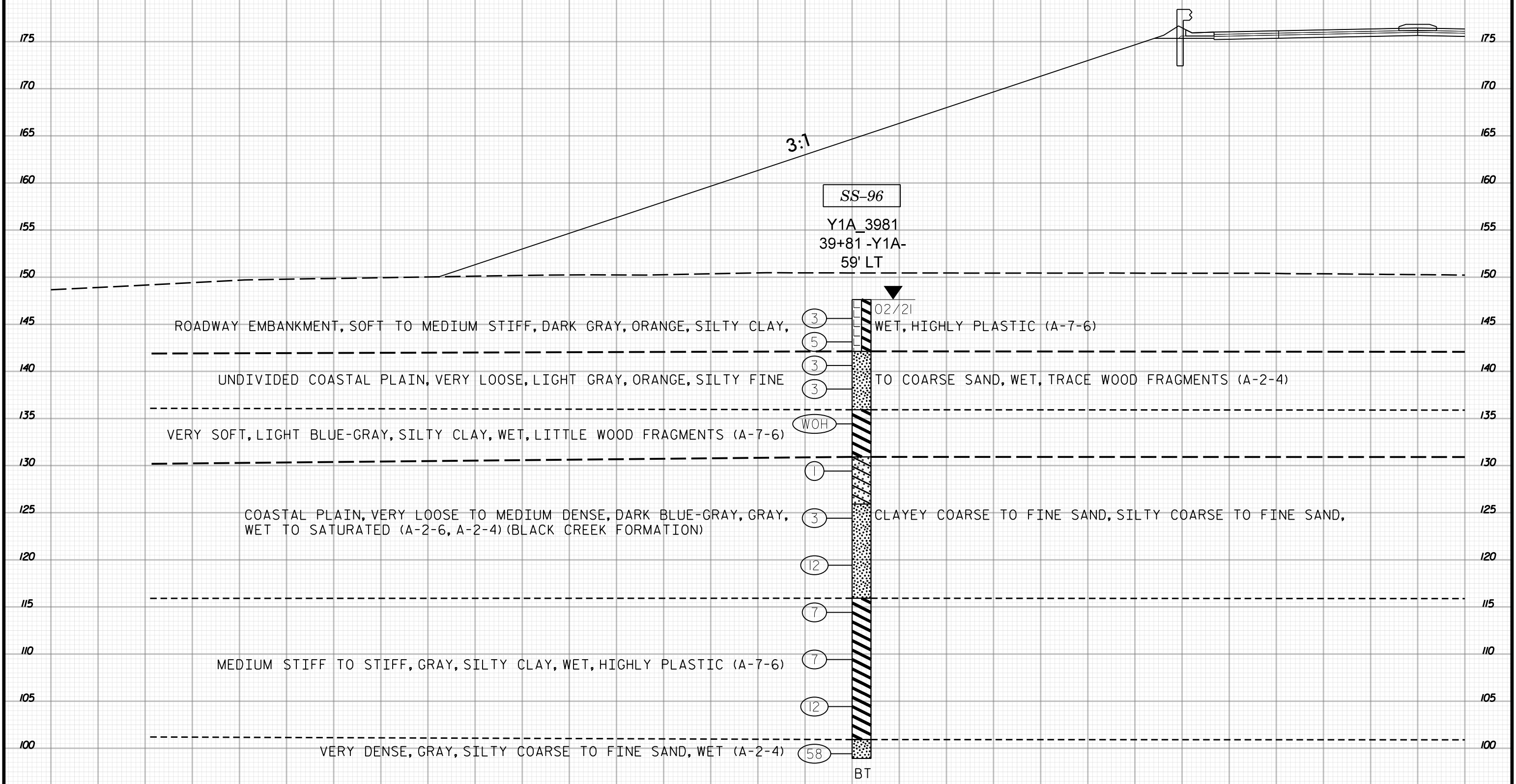

145 140 135 130 125 120 115 110 105 100 95 90 85 80 75 70 65 60 55 50 45 40 35 30 25 20 15 10 5 0 5

40+00  
1 OF 2  
-Y1A-

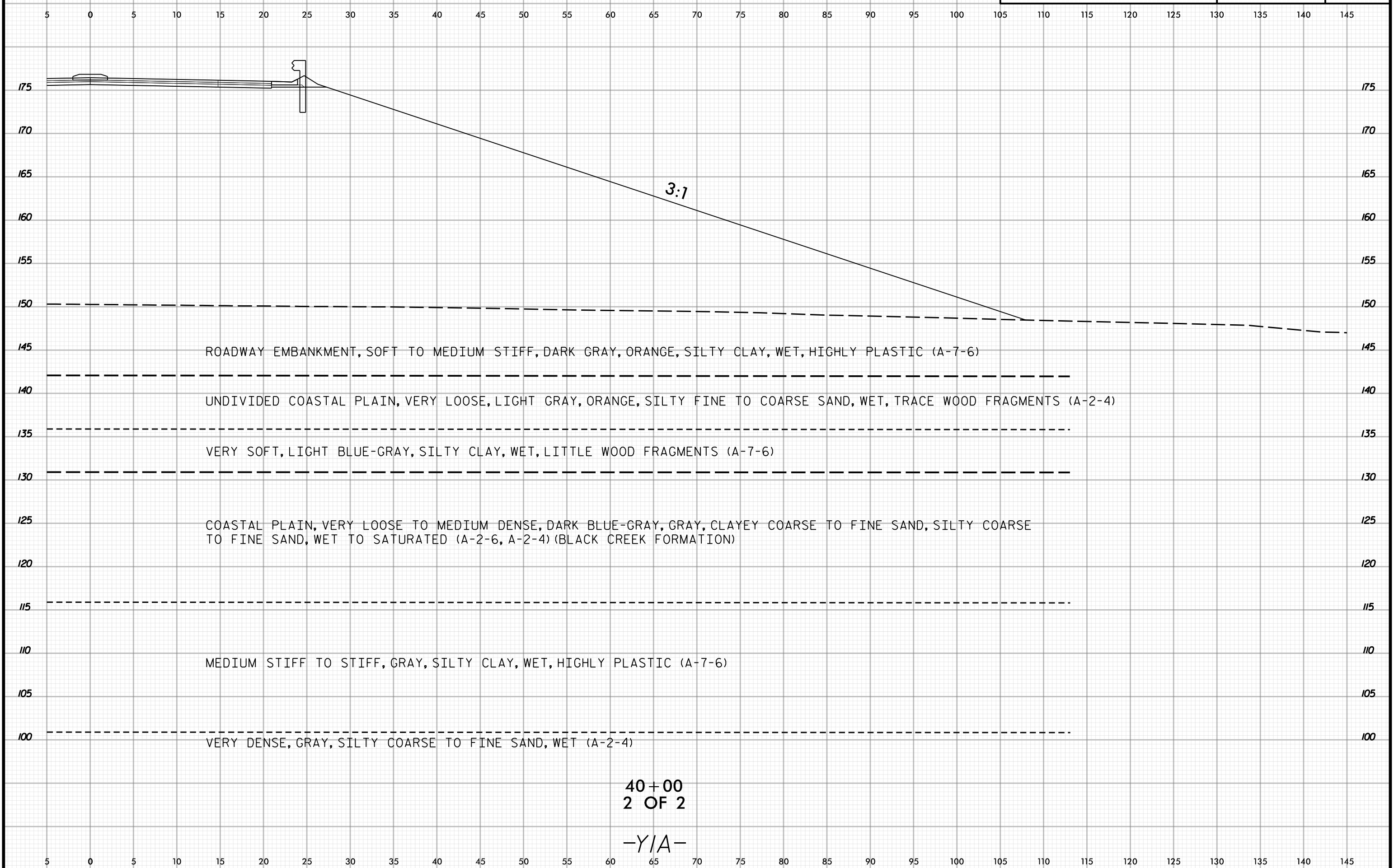

ROADWAY EMBANKMENT, SOFT TO MEDIUM STIFF, DARK GRAY, ORANGE, SILTY CLAY, WET, HIGHLY PLASTIC (A-7-6)

UNDIVIDED COASTAL PLAIN, VERY LOOSE, LIGHT GRAY, ORANGE, SILTY FINE TO COARSE SAND, WET, TRACE WOOD FRAGMENTS (A-2-4)

VERY SOFT, LIGHT BLUE-GRAY, SILTY CLAY, WET, LITTLE WOOD FRAGMENTS (A-7-6)

COASTAL PLAIN, VERY LOOSE TO MEDIUM DENSE, DARK BLUE-GRAY, GRAY, CLAYEY COARSE TO FINE SAND, SILTY COARSE TO FINE SAND, WET TO SATURATED (A-2-6, A-2-4) (BLACK CREEK FORMATION)

MEDIUM STIFF TO STIFF, GRAY, SILTY CLAY, WET, HIGHLY PLASTIC (A-7-6)

VERY DENSE, GRAY, SILTY COARSE TO FINE SAND, WET (A-2-4)

40+00  
2 OF 2

-Y/A-

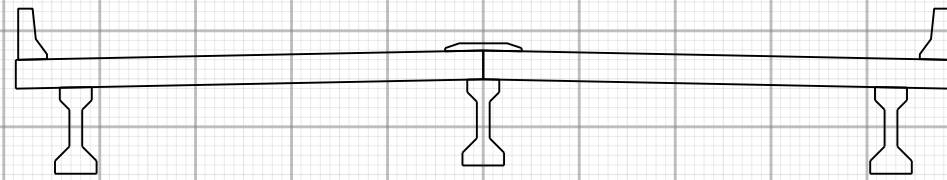
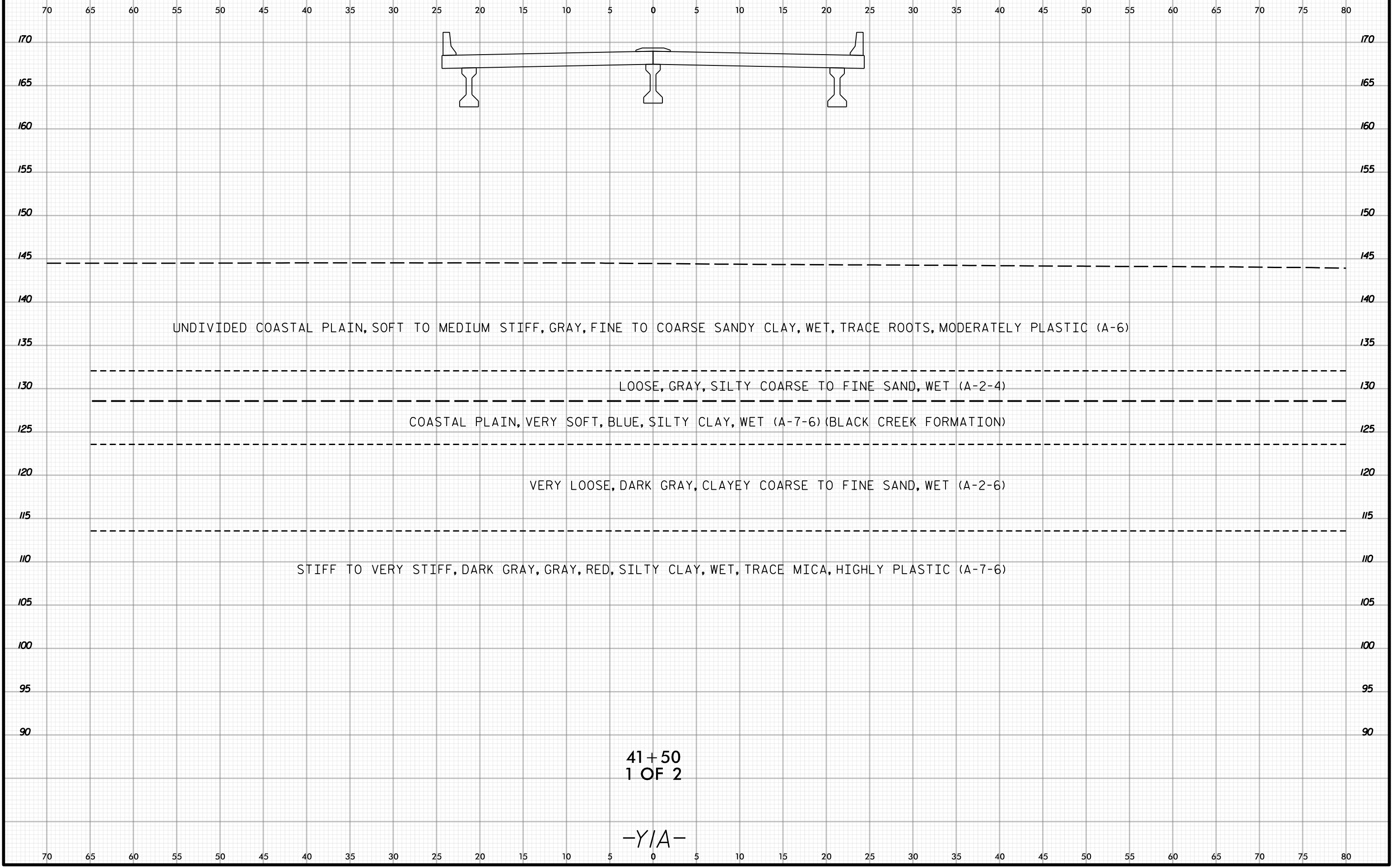

UNDIVIDED COASTAL PLAIN, SOFT TO MEDIUM STIFF, GRAY, FINE TO COARSE SANDY CLAY, WET, TRACE ROOTS, MODERATELY PLASTIC (A-6)

LOOSE, GRAY, SILTY COARSE TO FINE SAND, WET (A-2-4)

COASTAL PLAIN, VERY SOFT, BLUE, SILTY CLAY, WET (A-7-6) (BLACK CREEK FORMATION)

VERY LOOSE, DARK GRAY, CLAYEY COARSE TO FINE SAND, WET (A-2-6)

STIFF TO VERY STIFF, DARK GRAY, GRAY, RED, SILTY CLAY, WET, TRACE MICA, HIGHLY PLASTIC (A-7-6)

41+50  
1 OF 2

-Y/A-

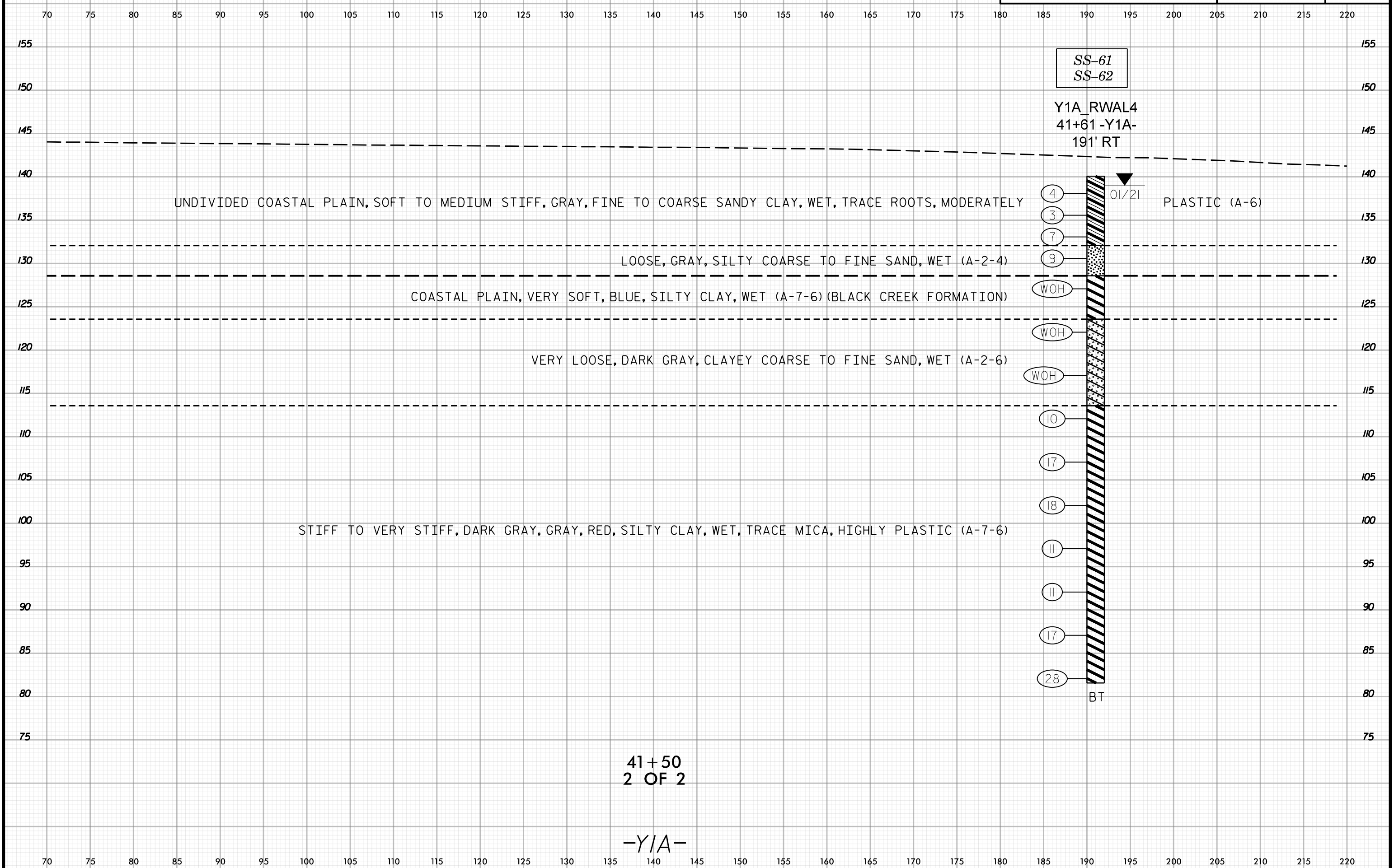
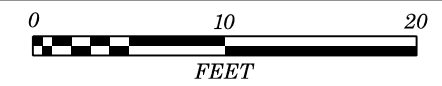

UNDIVIDED COASTAL PLAIN, SOFT TO MEDIUM STIFF, GRAY, FINE TO COARSE SANDY CLAY, WET, TRACE ROOTS, MODERATELY

PLASTIC (A-6)

LOOSE, GRAY, SILTY COARSE TO FINE SAND, WET (A-2-4)

COASTAL PLAIN, VERY SOFT, BLUE, SILTY CLAY, WET (A-7-6) (BLACK CREEK FORMATION)

VERY LOOSE, DARK GRAY, CLAYEY COARSE TO FINE SAND, WET (A-2-6)

STIFF TO VERY STIFF, DARK GRAY, GRAY, RED, SILTY CLAY, WET, TRACE MICA, HIGHLY PLASTIC (A-7-6)

41+50  
2 OF 2

-Y/A-

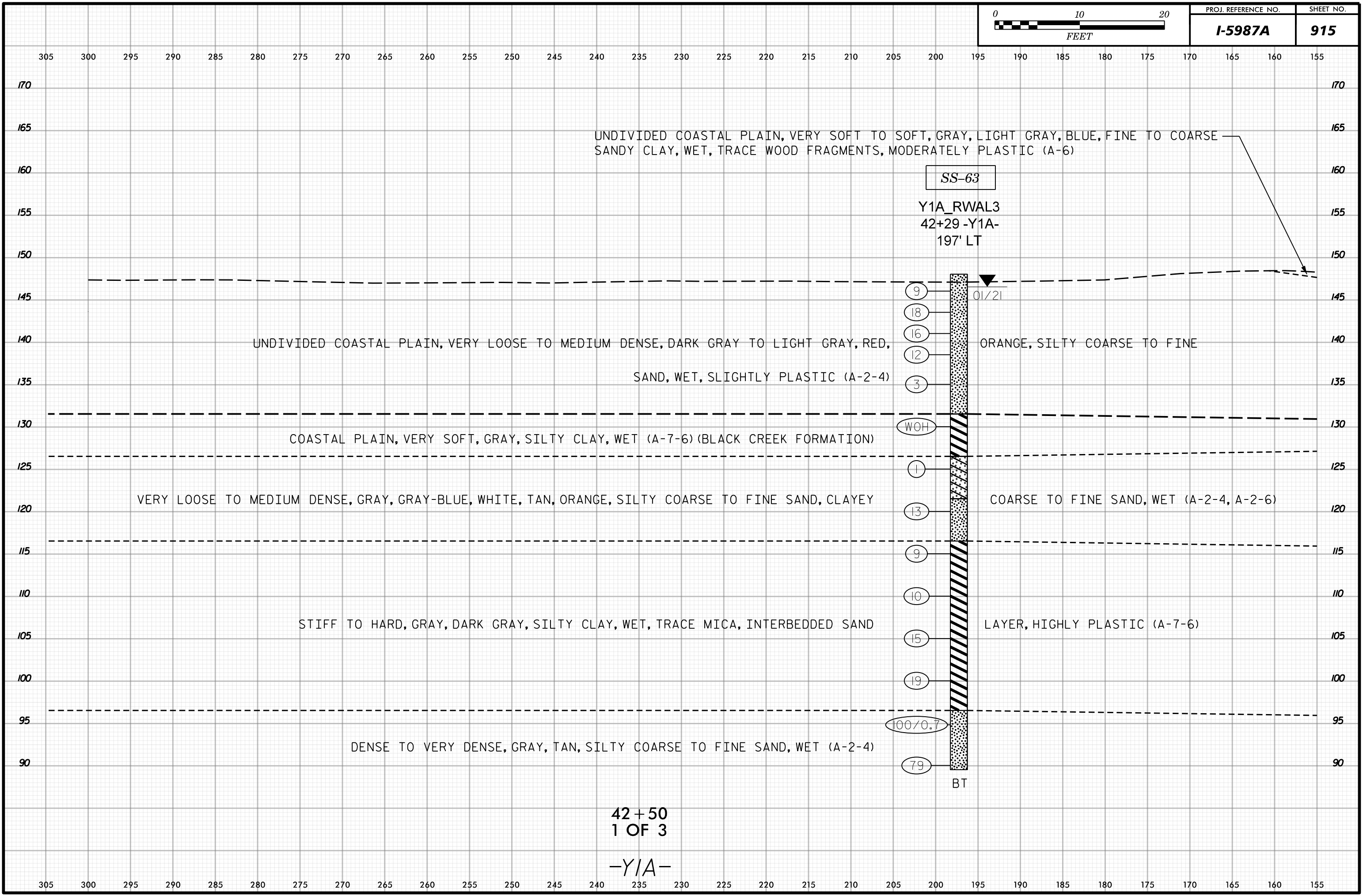

UNDIVIDED COASTAL PLAIN, VERY SOFT TO SOFT, GRAY, LIGHT GRAY, BLUE, FINE TO COARSE SANDY CLAY, WET, TRACE WOOD FRAGMENTS, MODERATELY PLASTIC (A-6)

SS-63

Y1A\_RWAL3  
42+29 -Y1A-  
197' LT

- 9
- 18
- 16
- 12
- 3
- WOH
- 1
- 13
- 9
- 10
- 15
- 19
- 100/0.7
- 79

01/21

UNDIVIDED COASTAL PLAIN, VERY LOOSE TO MEDIUM DENSE, DARK GRAY TO LIGHT GRAY, RED, SAND, WET, SLIGHTLY PLASTIC (A-2-4)

ORANGE, SILTY COARSE TO FINE

COASTAL PLAIN, VERY SOFT, GRAY, SILTY CLAY, WET (A-7-6) (BLACK CREEK FORMATION)

VERY LOOSE TO MEDIUM DENSE, GRAY, GRAY-BLUE, WHITE, TAN, ORANGE, SILTY COARSE TO FINE SAND, CLAYEY

COARSE TO FINE SAND, WET (A-2-4, A-2-6)

STIFF TO HARD, GRAY, DARK GRAY, SILTY CLAY, WET, TRACE MICA, INTERBEDDED SAND

LAYER, HIGHLY PLASTIC (A-7-6)

DENSE TO VERY DENSE, GRAY, TAN, SILTY COARSE TO FINE SAND, WET (A-2-4)

BT

42+50  
1 OF 3

-Y/A-

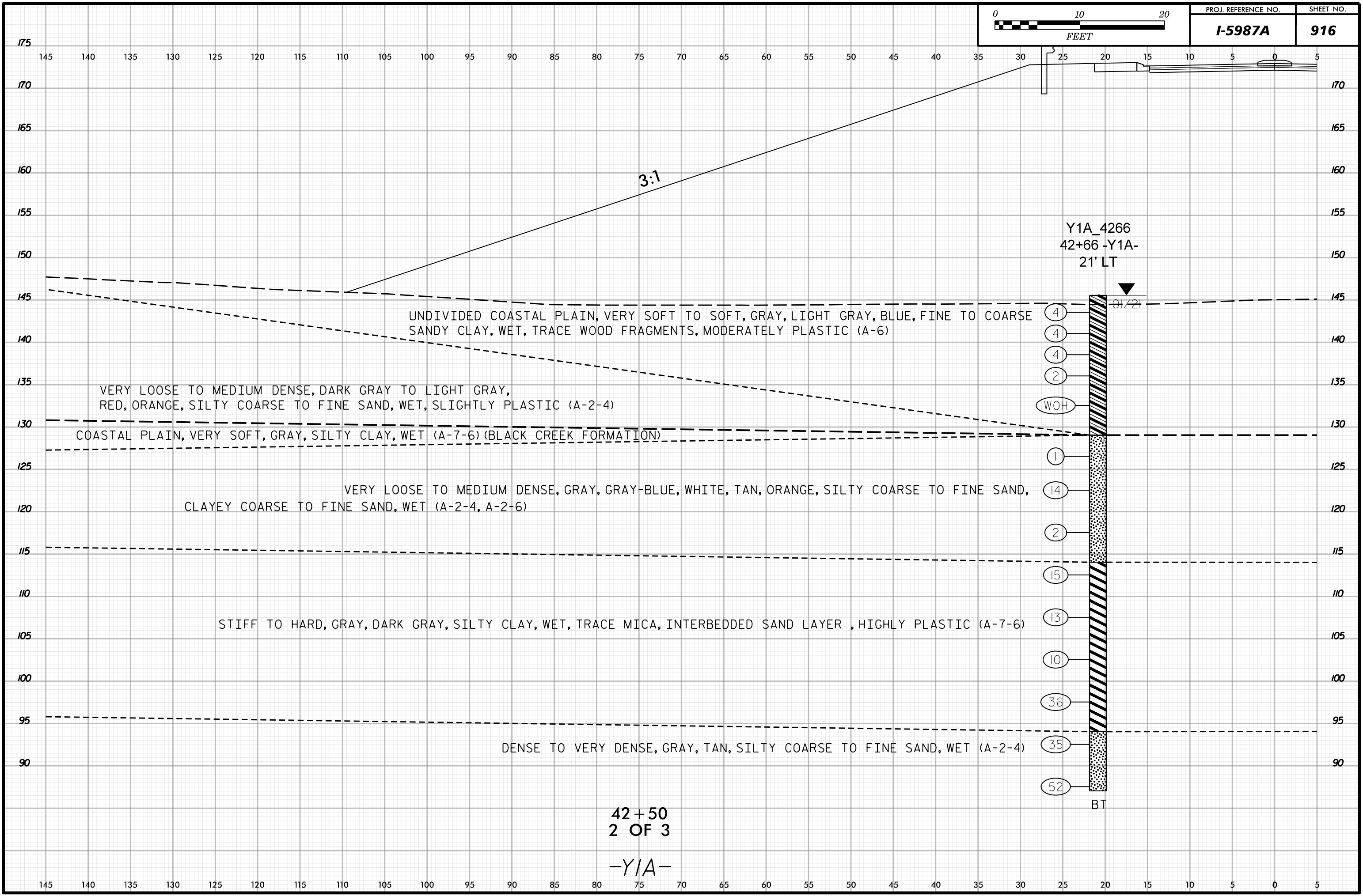
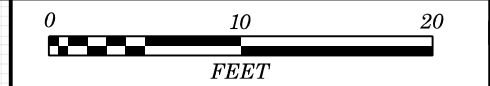

Y1A\_4266  
42+66 -Y1A-  
21' LT

UNDIVIDED COASTAL PLAIN, VERY SOFT TO SOFT, GRAY, LIGHT GRAY, BLUE, FINE TO COARSE SANDY CLAY, WET, TRACE WOOD FRAGMENTS, MODERATELY PLASTIC (A-6)

VERY LOOSE TO MEDIUM DENSE, DARK GRAY TO LIGHT GRAY, RED, ORANGE, SILTY COARSE TO FINE SAND, WET, SLIGHTLY PLASTIC (A-2-4)

COASTAL PLAIN, VERY SOFT, GRAY, SILTY CLAY, WET (A-7-6) (BLACK CREEK FORMATION)

VERY LOOSE TO MEDIUM DENSE, GRAY, GRAY-BLUE, WHITE, TAN, ORANGE, SILTY COARSE TO FINE SAND, CLAYEY COARSE TO FINE SAND, WET (A-2-4, A-2-6)

STIFF TO HARD, GRAY, DARK GRAY, SILTY CLAY, WET, TRACE MICA, INTERBEDDED SAND LAYER, HIGHLY PLASTIC (A-7-6)

DENSE TO VERY DENSE, GRAY, TAN, SILTY COARSE TO FINE SAND, WET (A-2-4)

42+50  
2 OF 3

-Y/A-

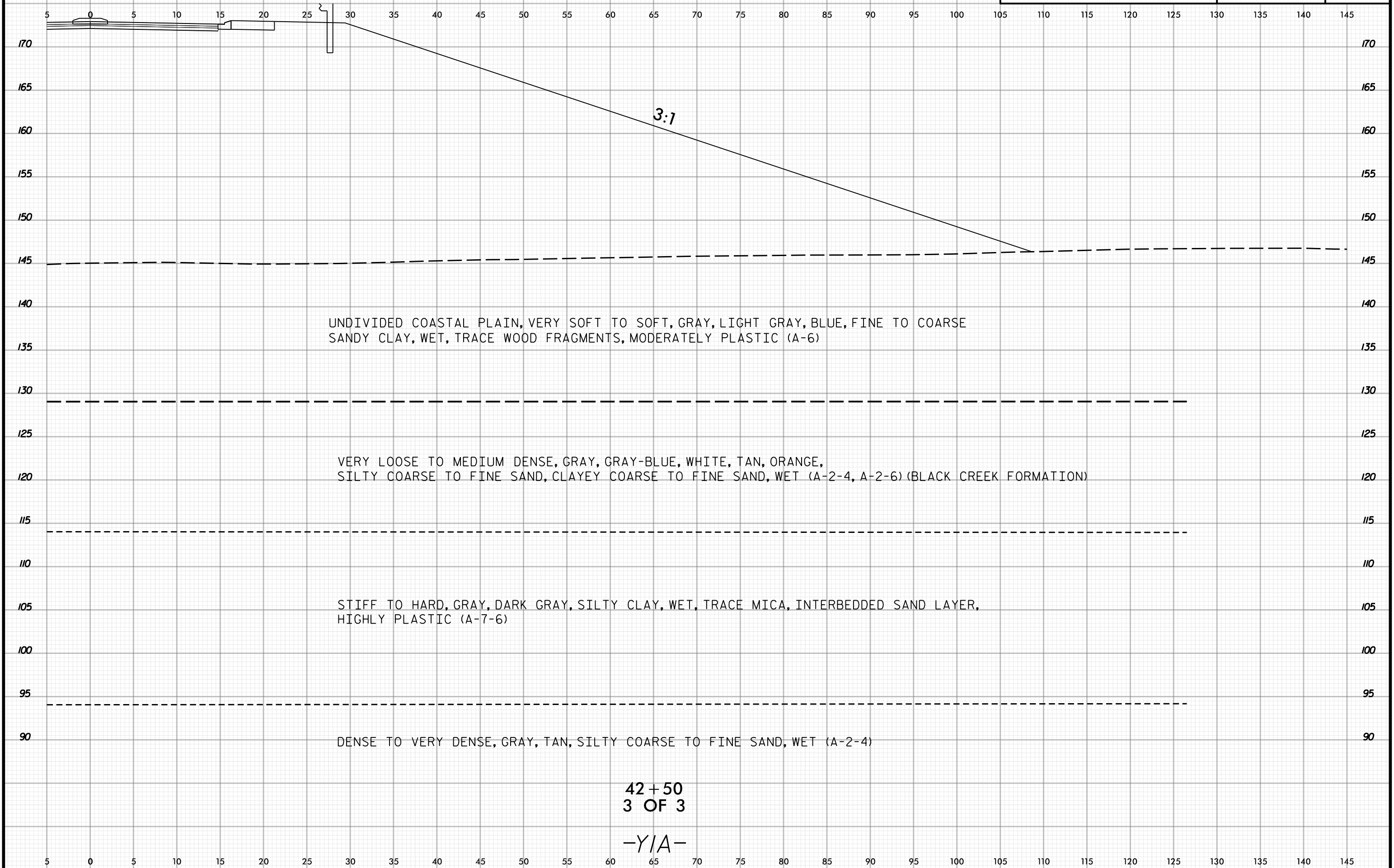



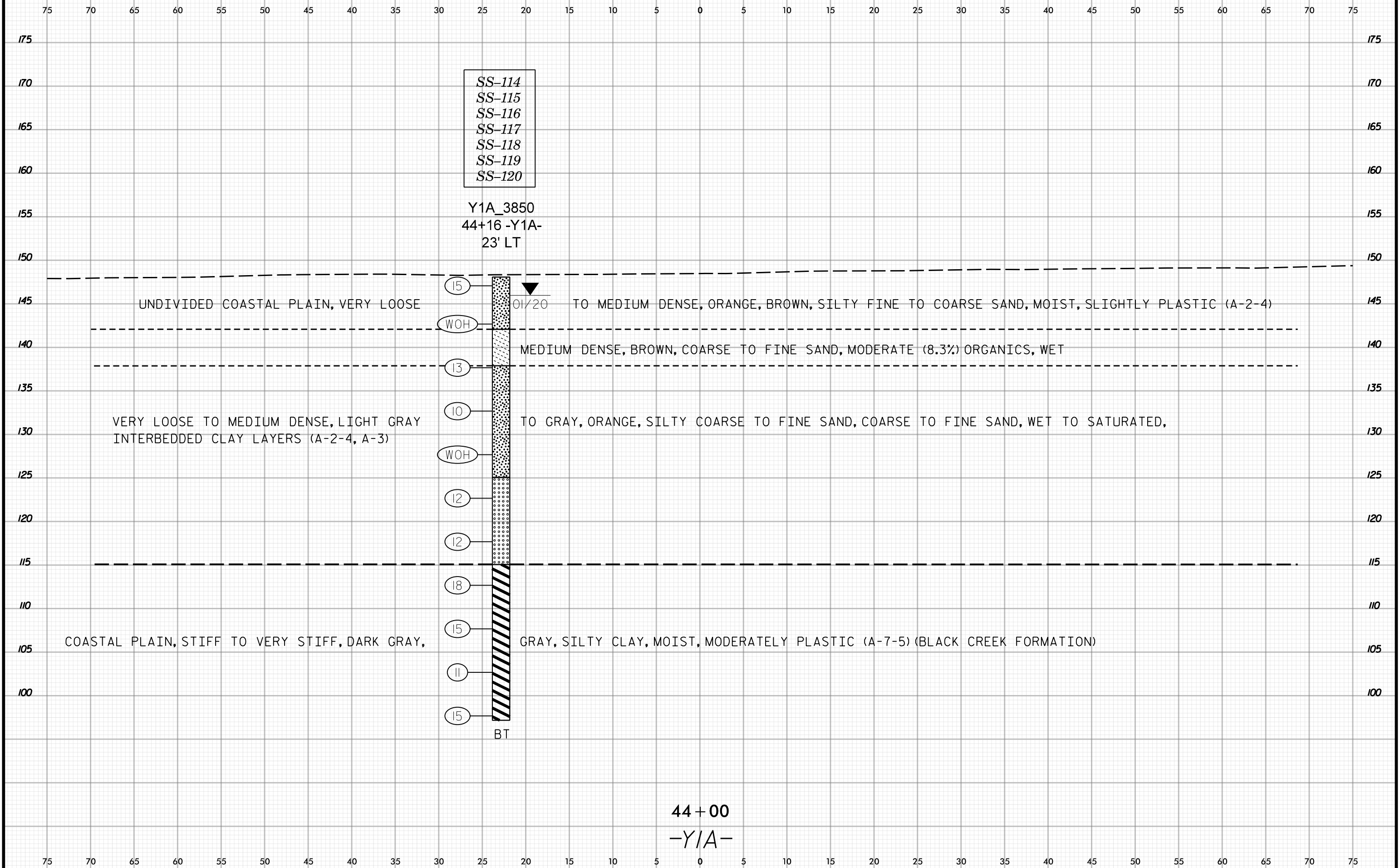

UNDIVIDED COASTAL PLAIN, VERY LOOSE

TO MEDIUM DENSE, ORANGE, BROWN, SILTY FINE TO COARSE SAND, MOIST, SLIGHTLY PLASTIC (A-2-4)

MEDIUM DENSE, BROWN, COARSE TO FINE SAND, MODERATE (8.3%) ORGANICS, WET

VERY LOOSE TO MEDIUM DENSE, LIGHT GRAY INTERBEDDED CLAY LAYERS (A-2-4, A-3)

TO GRAY, ORANGE, SILTY COARSE TO FINE SAND, COARSE TO FINE SAND, WET TO SATURATED,

COASTAL PLAIN, STIFF TO VERY STIFF, DARK GRAY,

GRAY, SILTY CLAY, MOIST, MODERATELY PLASTIC (A-7-5) (BLACK CREEK FORMATION)

BT

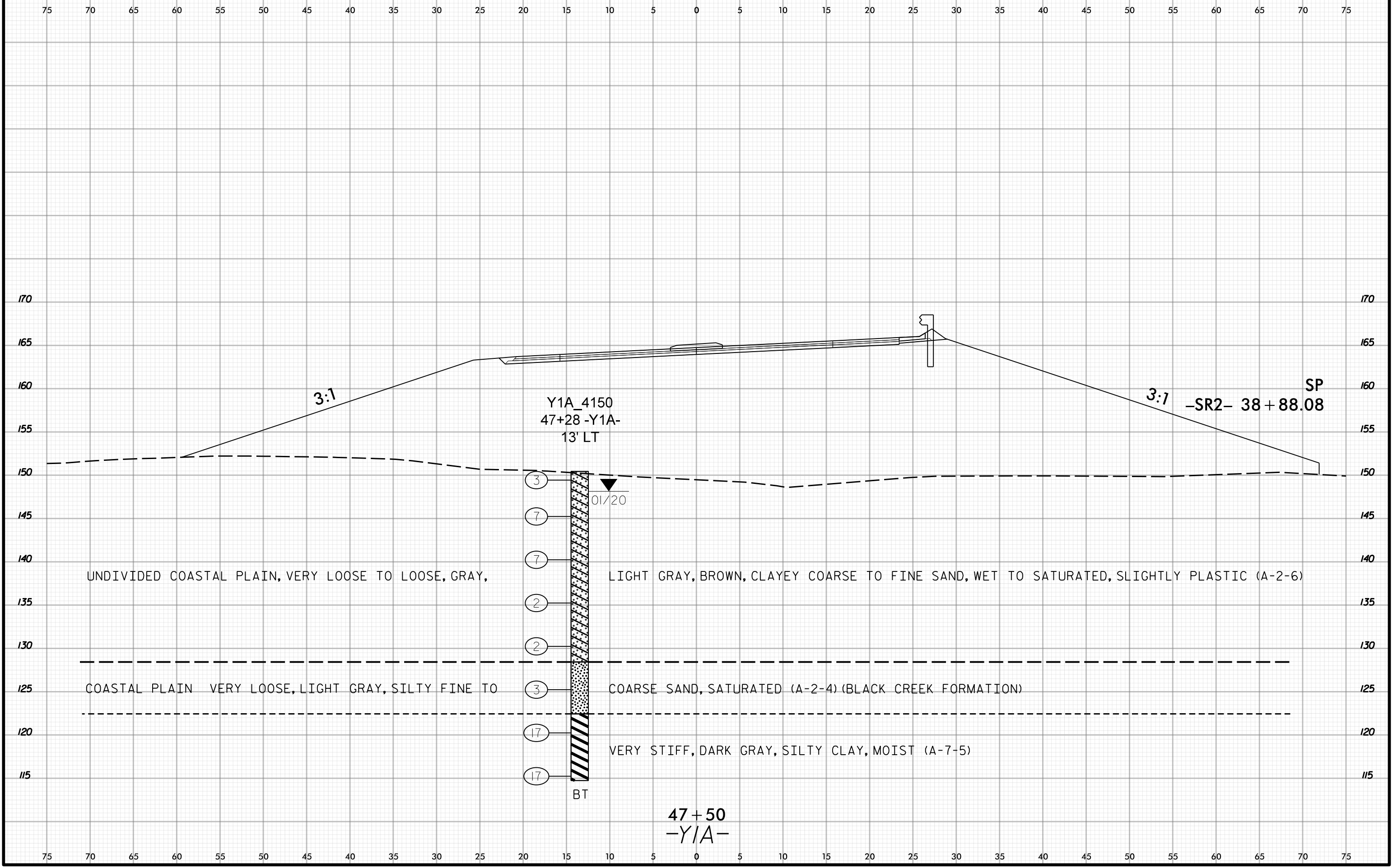
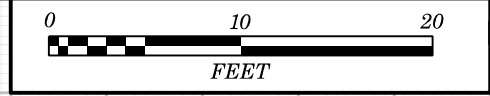

3:1

3:1

Y1A\_4150  
47+28 -Y1A-  
13' LT

SP  
-SR2- 38+88.08

01/20

UNDIVIDED COASTAL PLAIN, VERY LOOSE TO LOOSE, GRAY,

LIGHT GRAY, BROWN, CLAYEY COARSE TO FINE SAND, WET TO SATURATED, SLIGHTLY PLASTIC (A-2-6)

COASTAL PLAIN VERY LOOSE, LIGHT GRAY, SILTY FINE TO

COARSE SAND, SATURATED (A-2-4) (BLACK CREEK FORMATION)

VERY STIFF, DARK GRAY, SILTY CLAY, MOIST (A-7-5)

BT

47+50  
-Y1A-

- 3
- 7
- 7
- 2
- 2
- 3
- 17
- 17

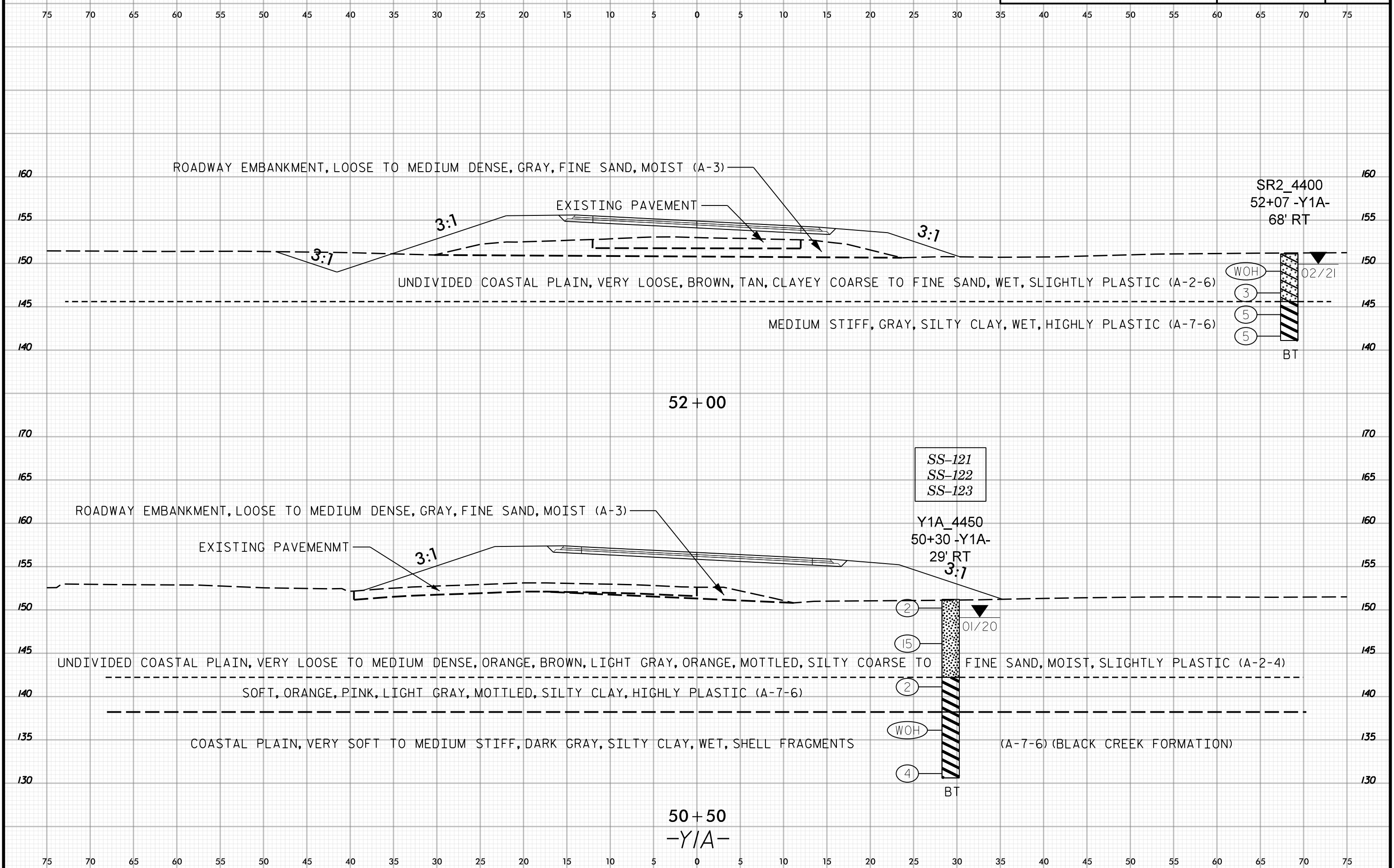
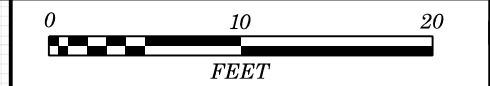



75 70 65 60 55 50 45 40 35 30 25 20 15 10 5 0 5 10 15 20 25 30 35 40 45 50 55 60 65 70 75

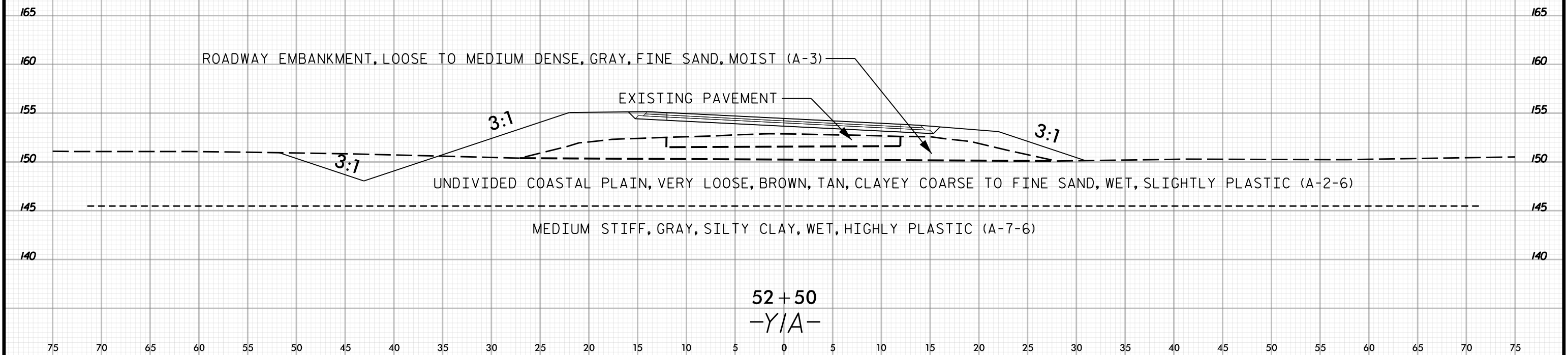
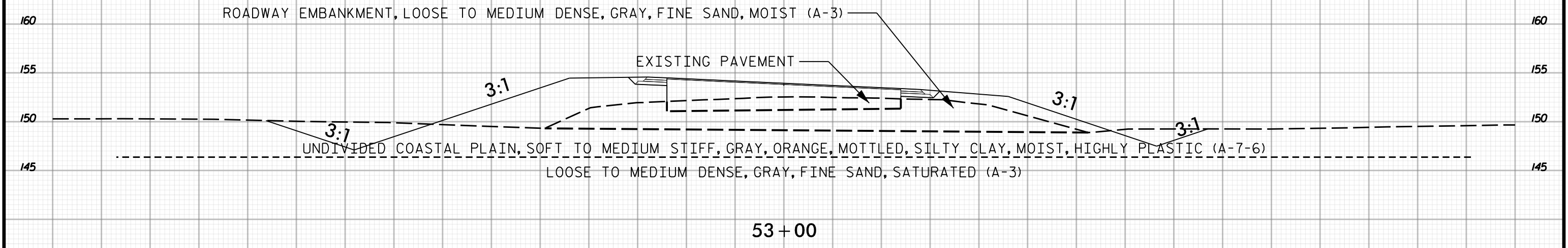



75 70 65 60 55 50 45 40 35 30 25 20 15 10 5 0 5 10 15 20 25 30 35 40 45 50 55 60 65 70 75

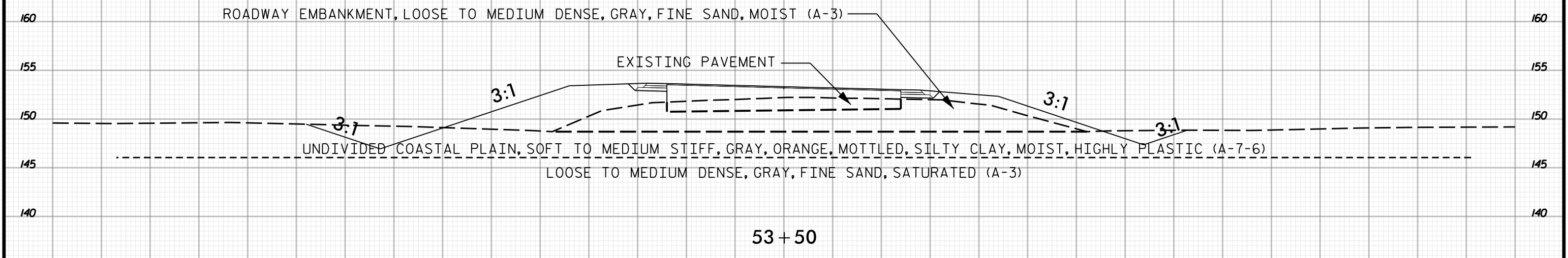
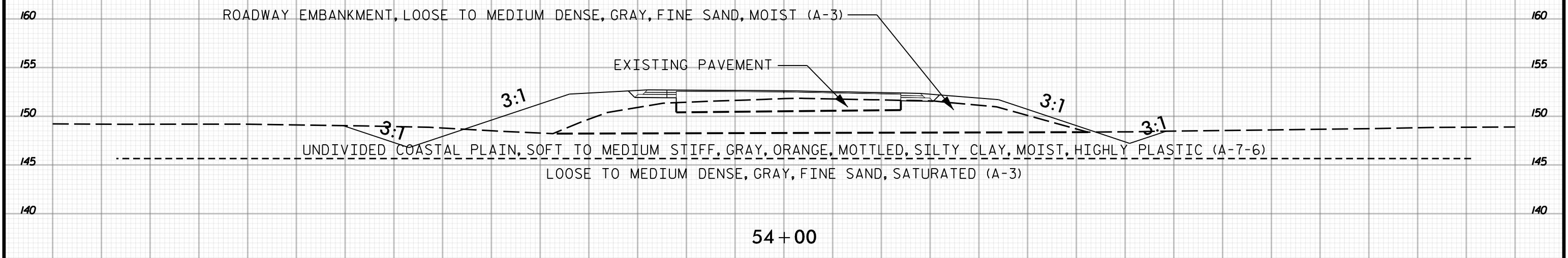

-Y/A-

75 70 65 60 55 50 45 40 35 30 25 20 15 10 5 0 5 10 15 20 25 30 35 40 45 50 55 60 65 70 75

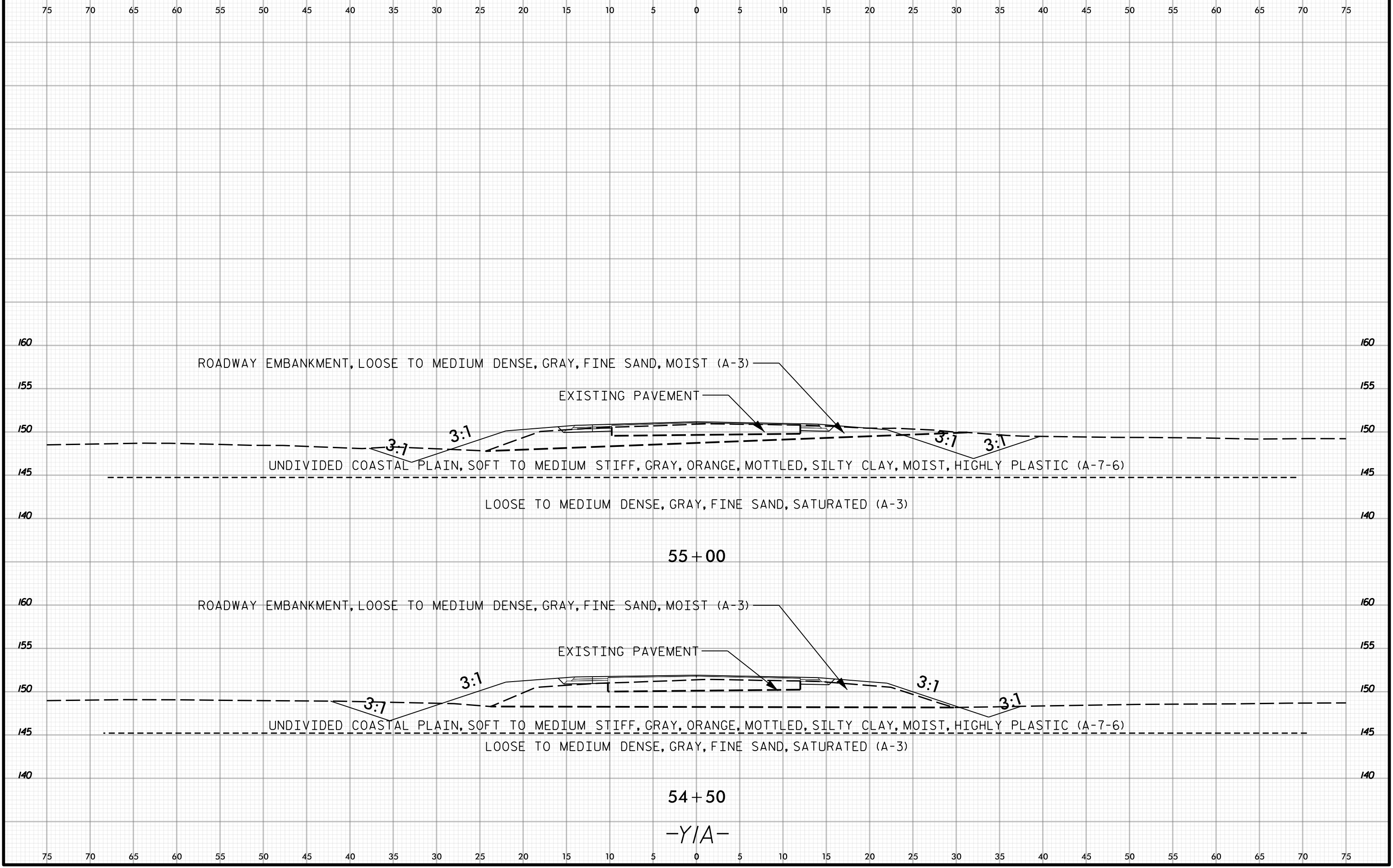

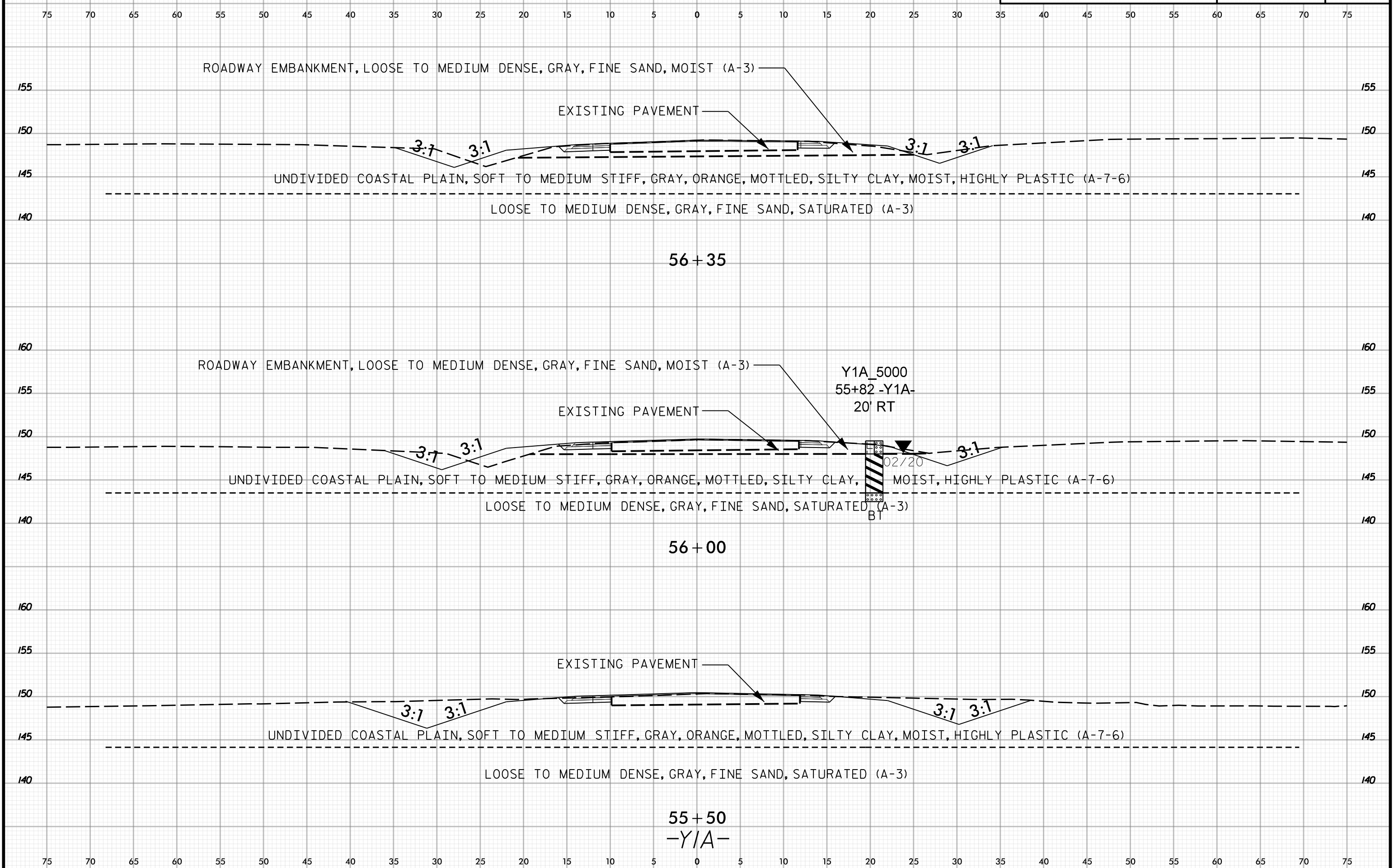

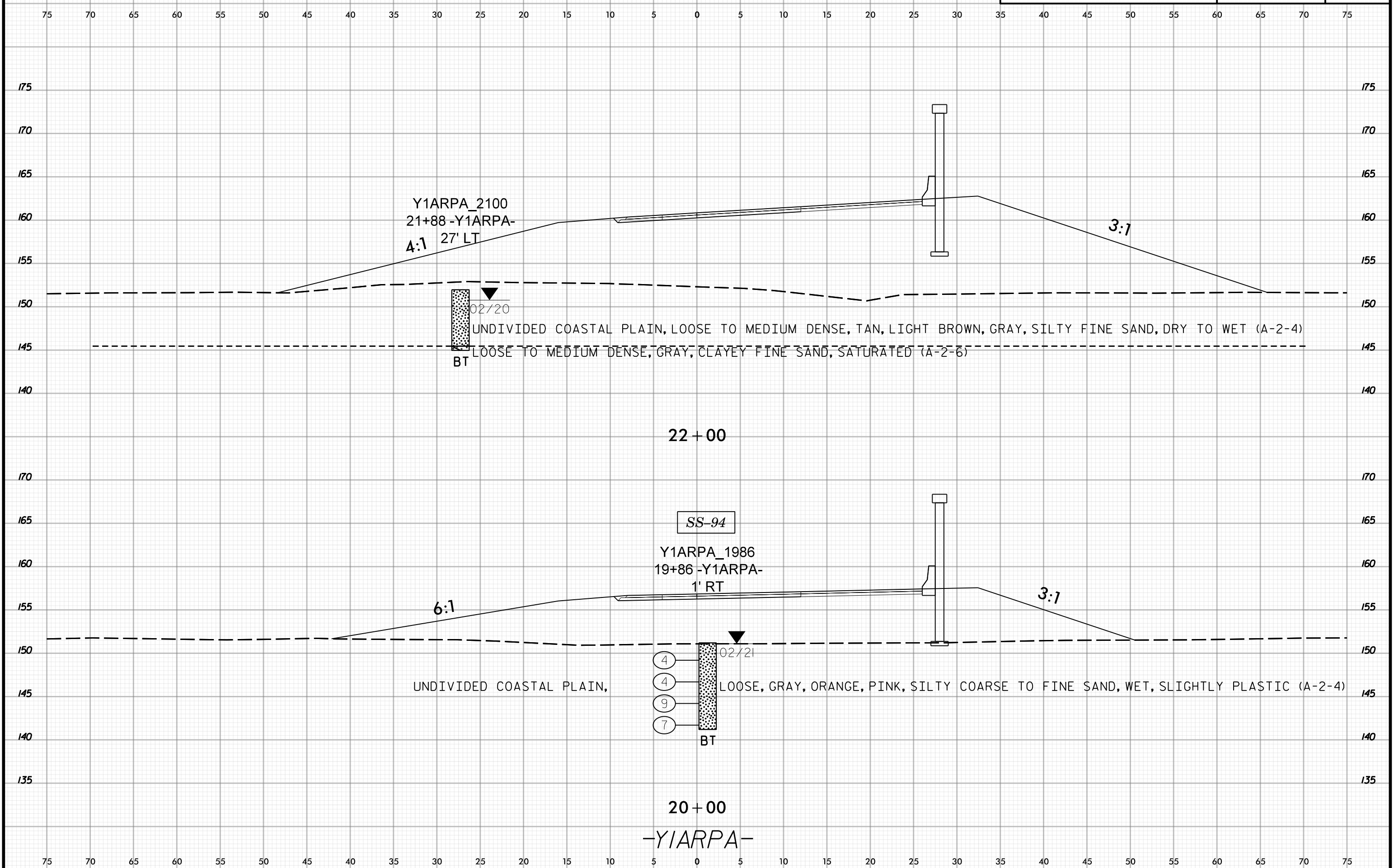
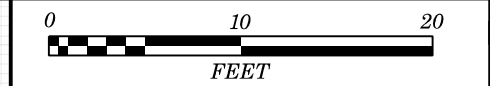



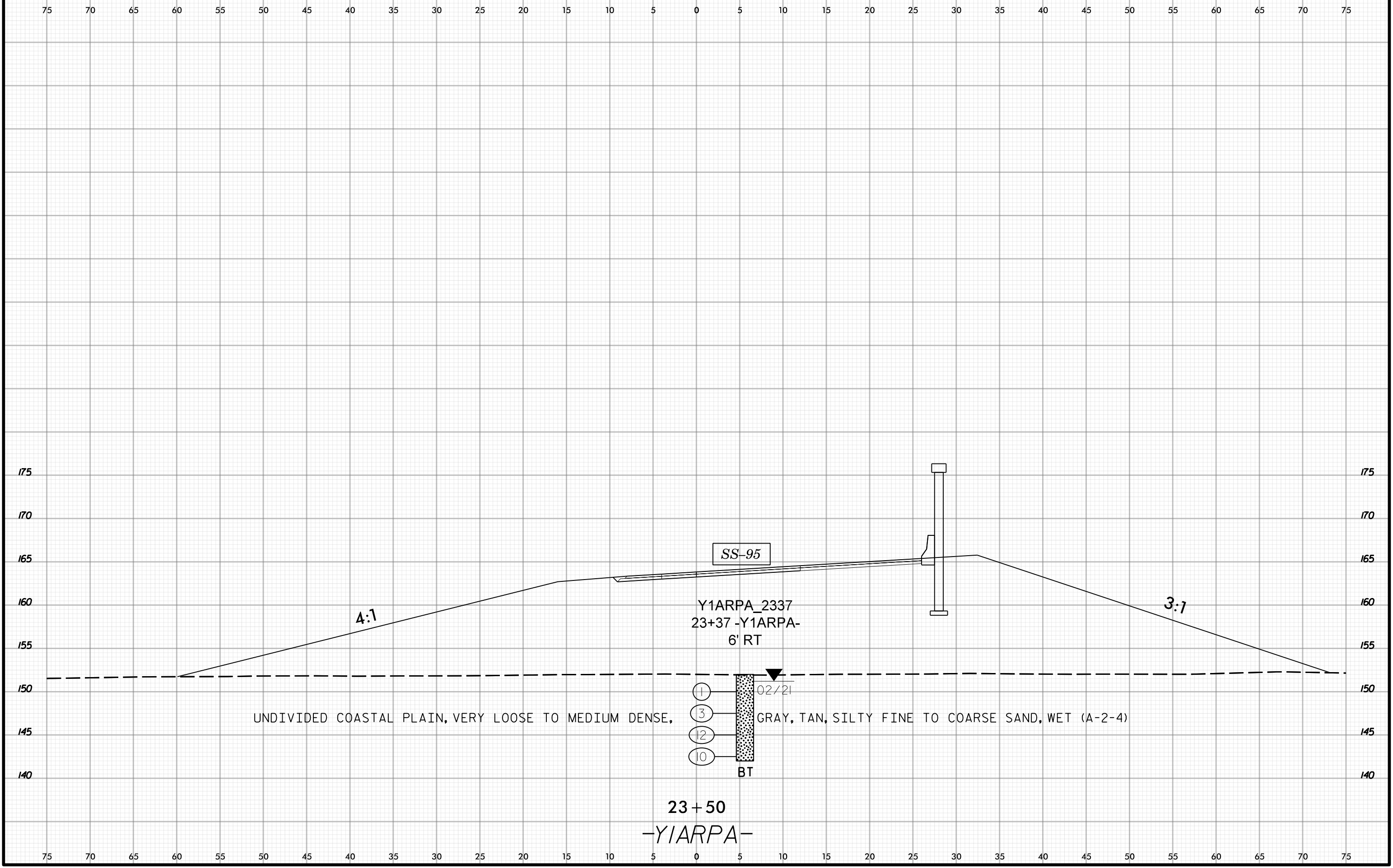

SS-95

Y1ARPA\_2337  
23+37 -Y1ARPA-  
6' RT

4:1

3:1

UNDIVIDED COASTAL PLAIN, VERY LOOSE TO MEDIUM DENSE,

- ①
- ③
- ⑫
- ⑩

02/21  
GRAY, TAN, SILTY FINE TO COARSE SAND, WET (A-2-4)

BT

23 + 50  
-Y1ARPA-

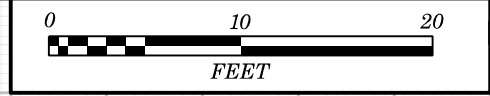

PROJ. REFERENCE NO.	SHEET NO.
I-5987A	927

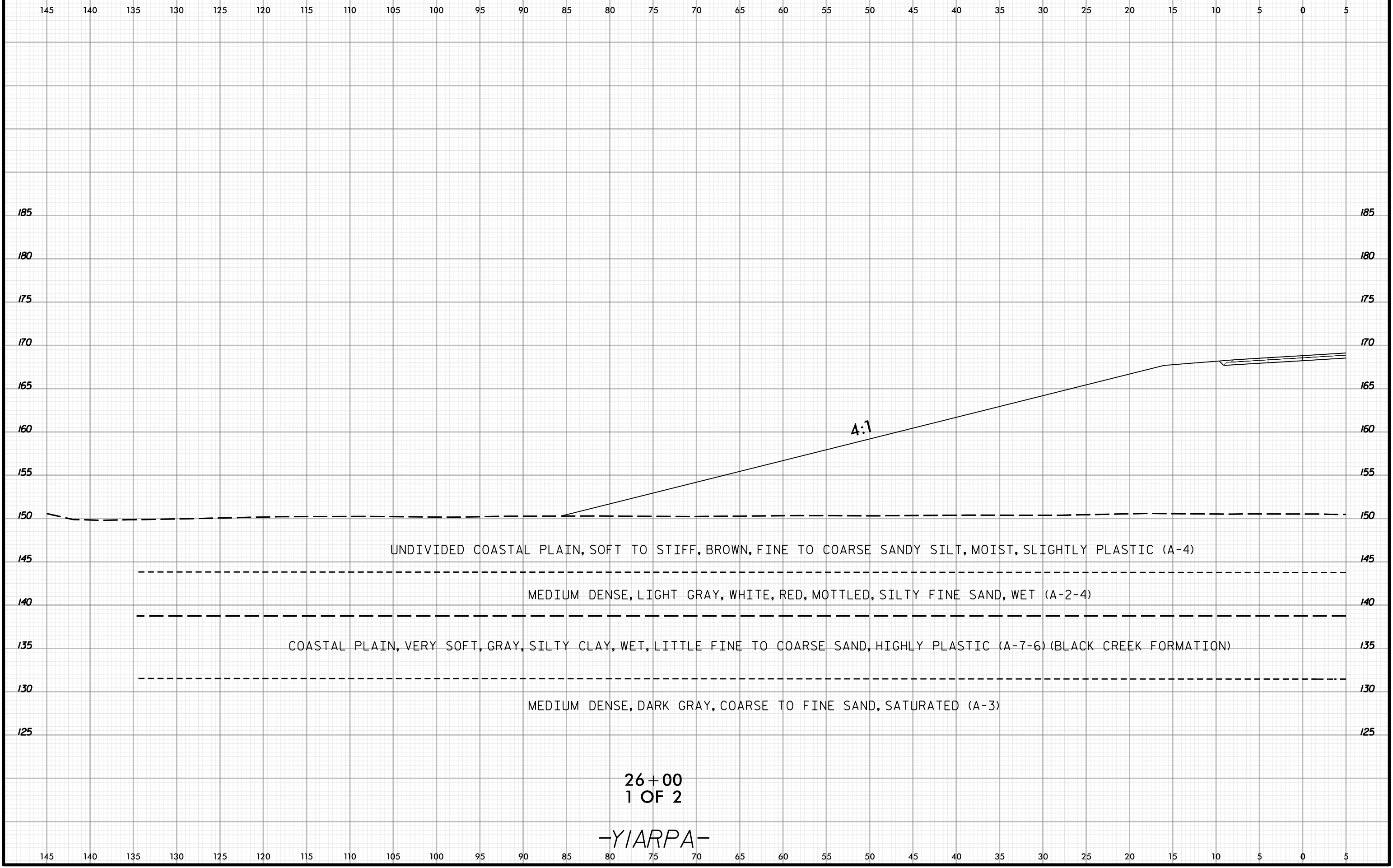

26+00  
1 OF 2  
-YIARPA-

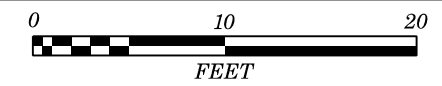

5 0 5 10 15 20 25 30 35 40 45 50 55 60 65 70 75 80 85 90 95 100 105 110 115 120 125 130 135 140 145

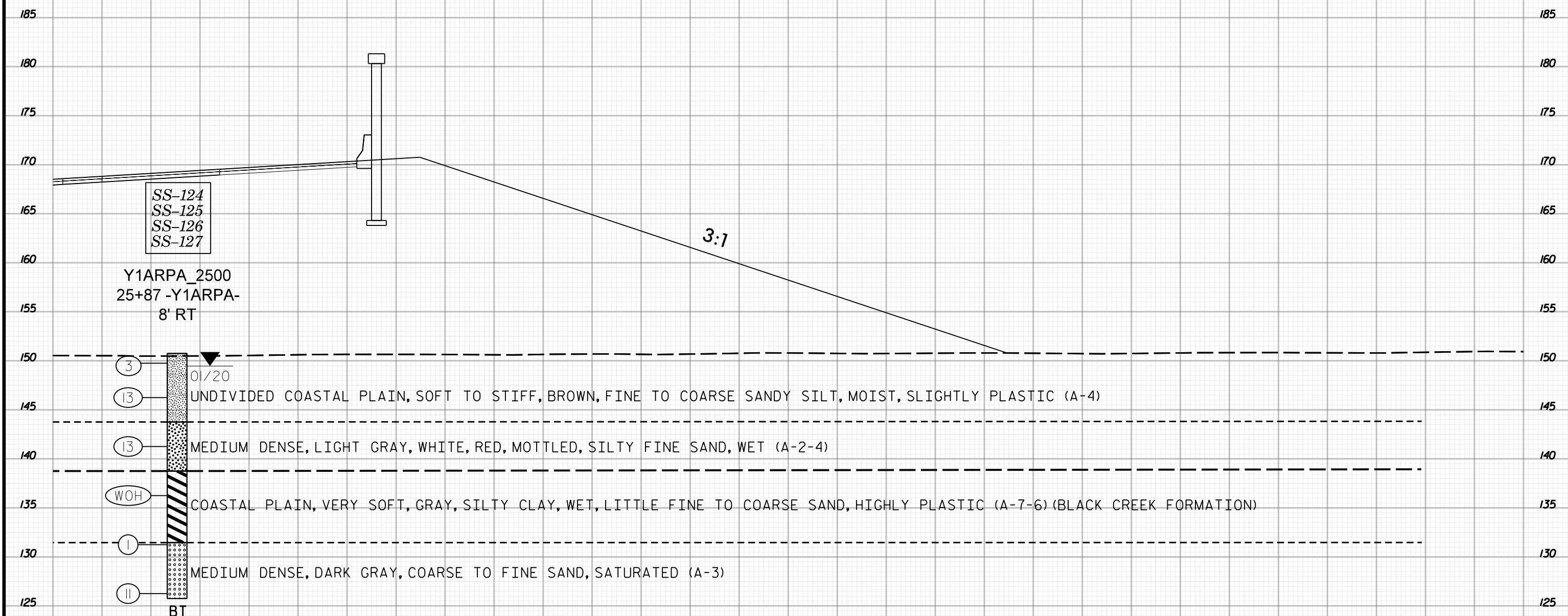

26+00  
2 OF 2  
-Y1ARPA-

5 0 5 10 15 20 25 30 35 40 45 50 55 60 65 70 75 80 85 90 95 100 105 110 115 120 125 130 135 140 145

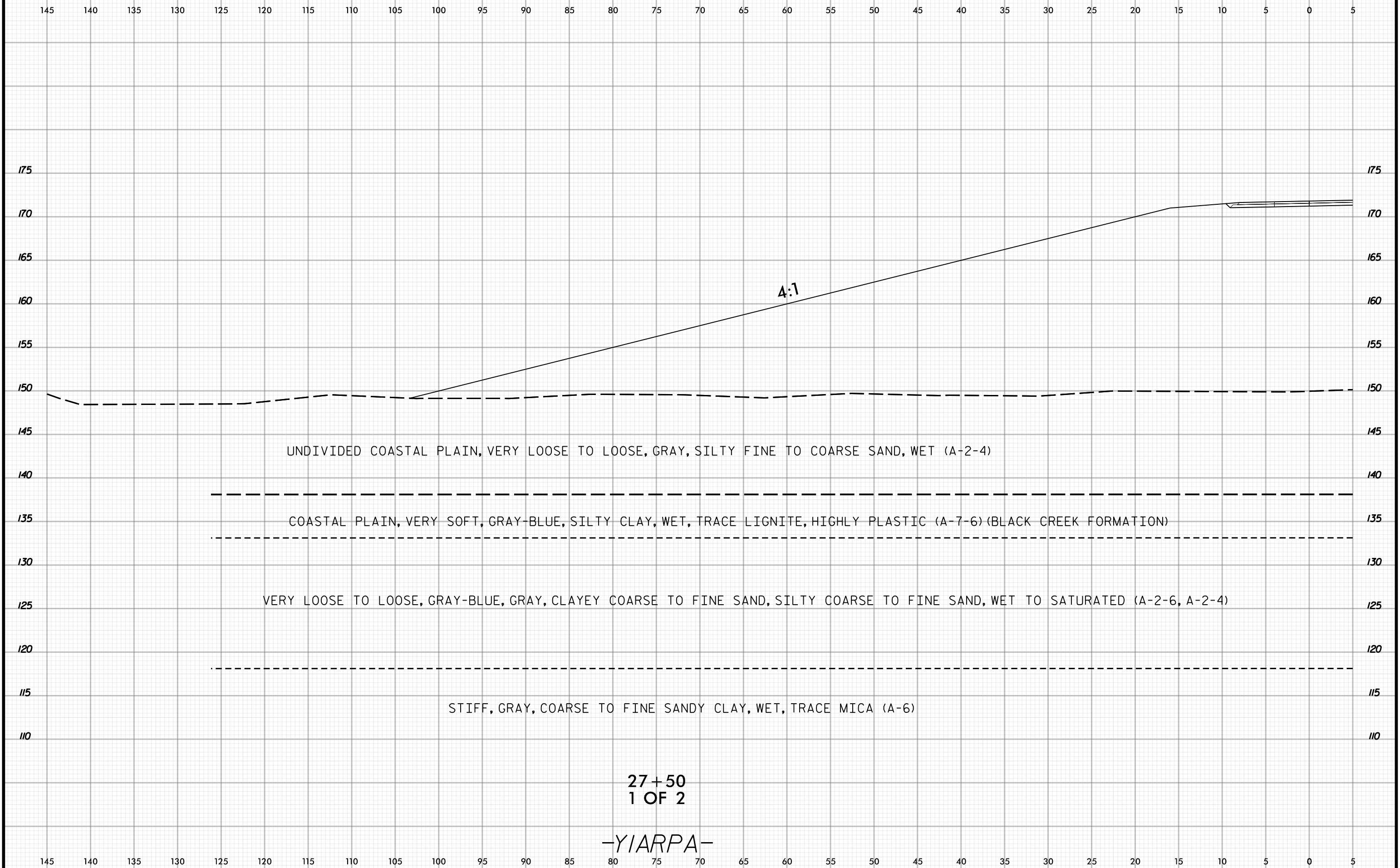

27+50  
1 OF 2

-YIARPA-

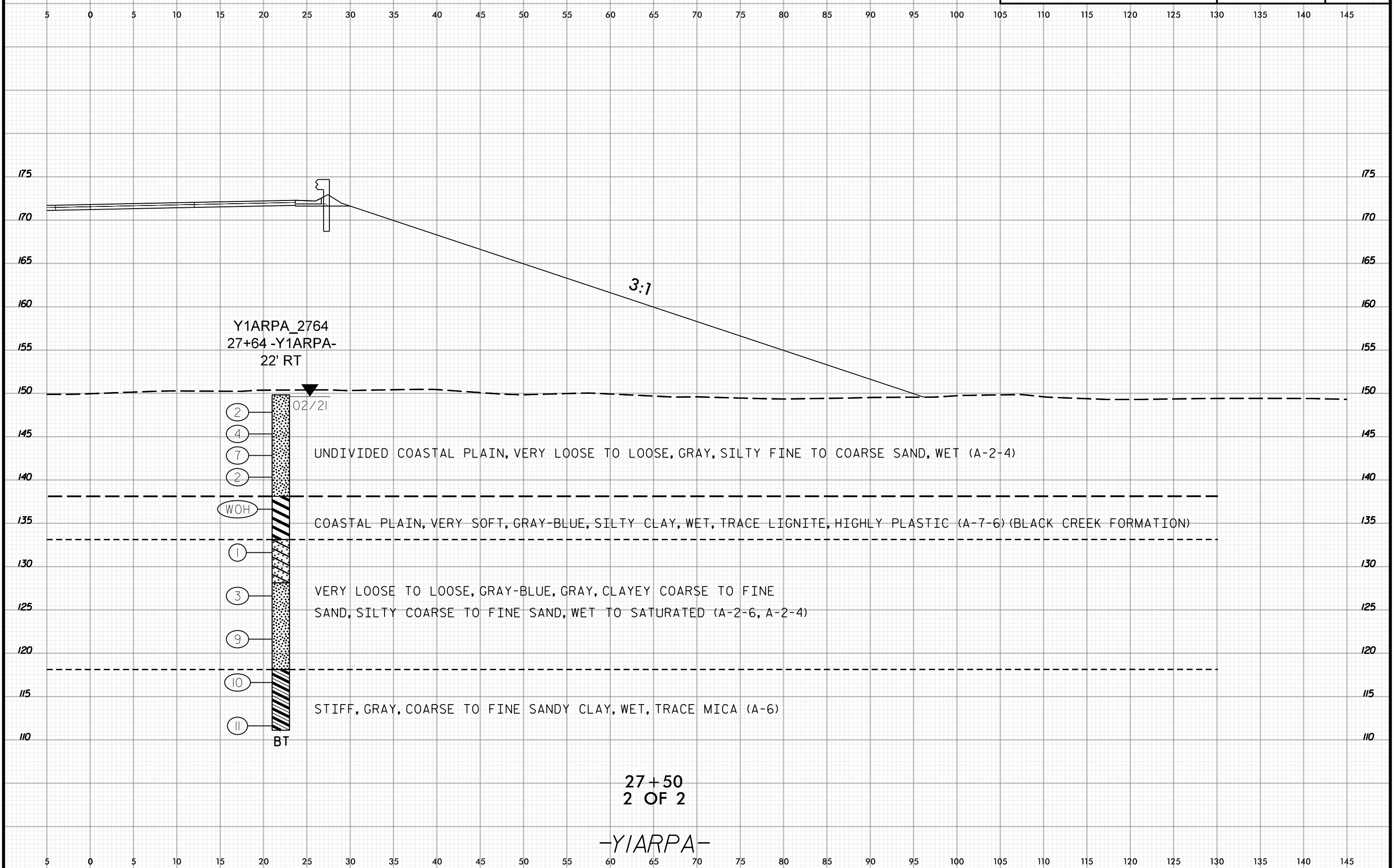

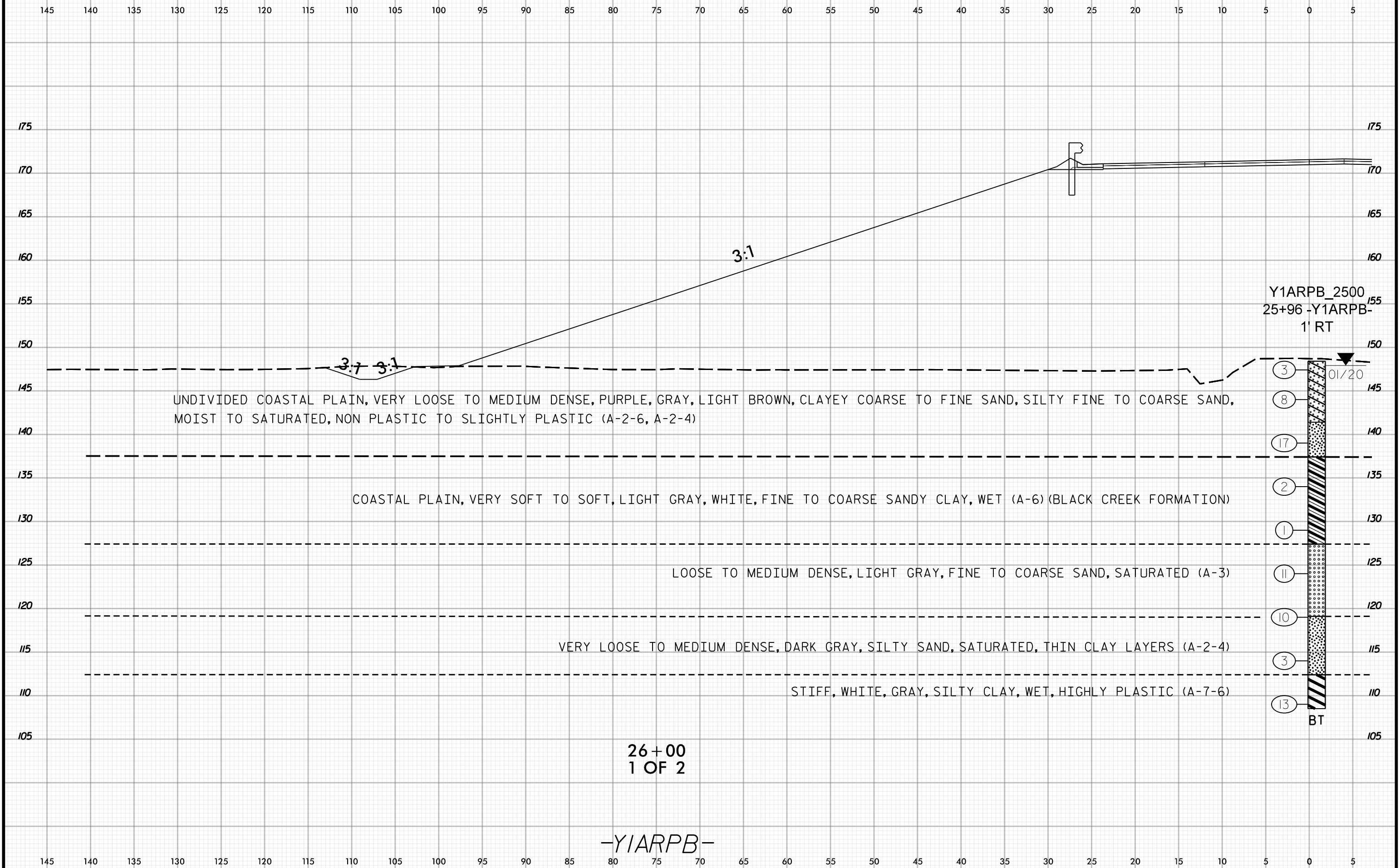

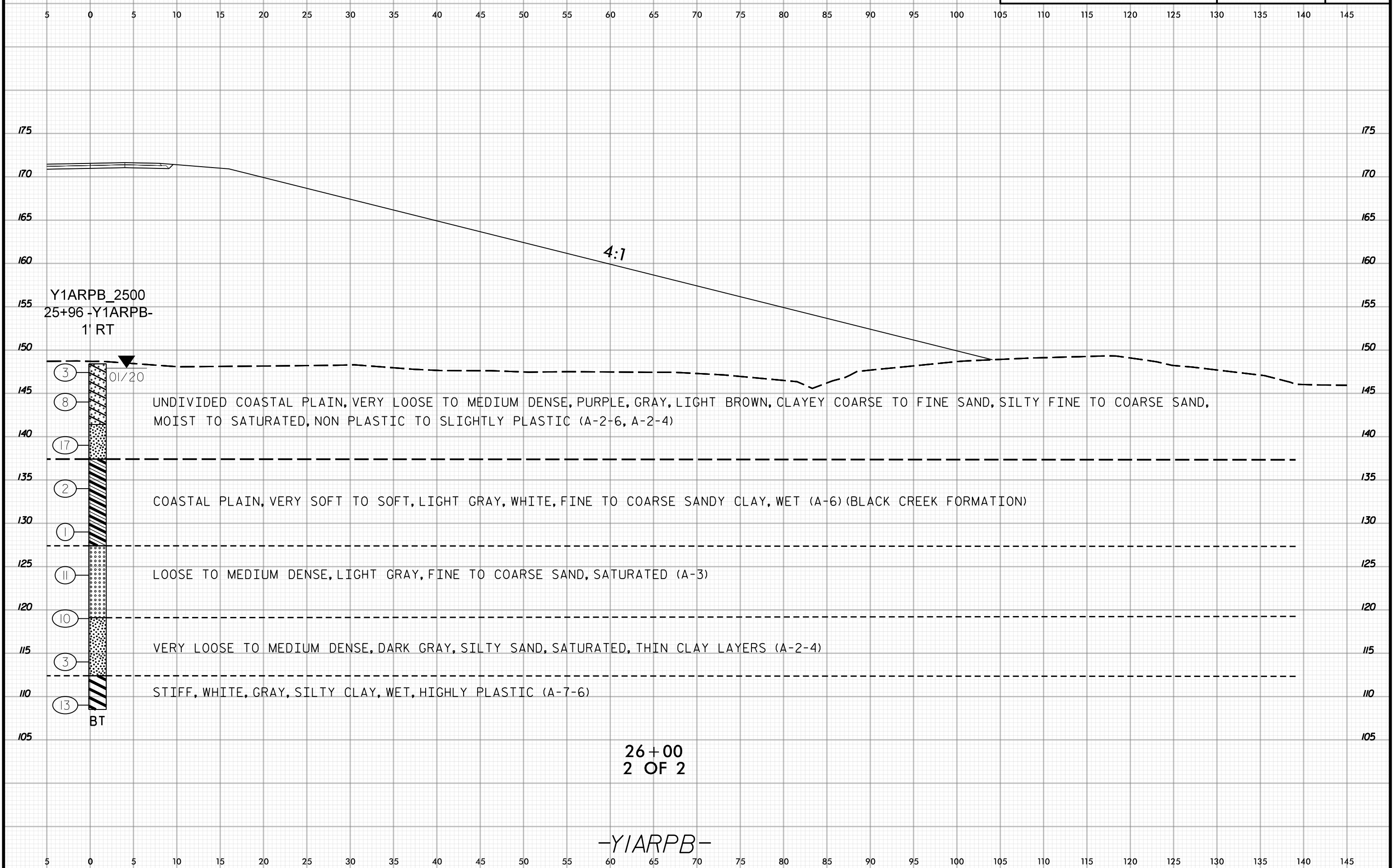

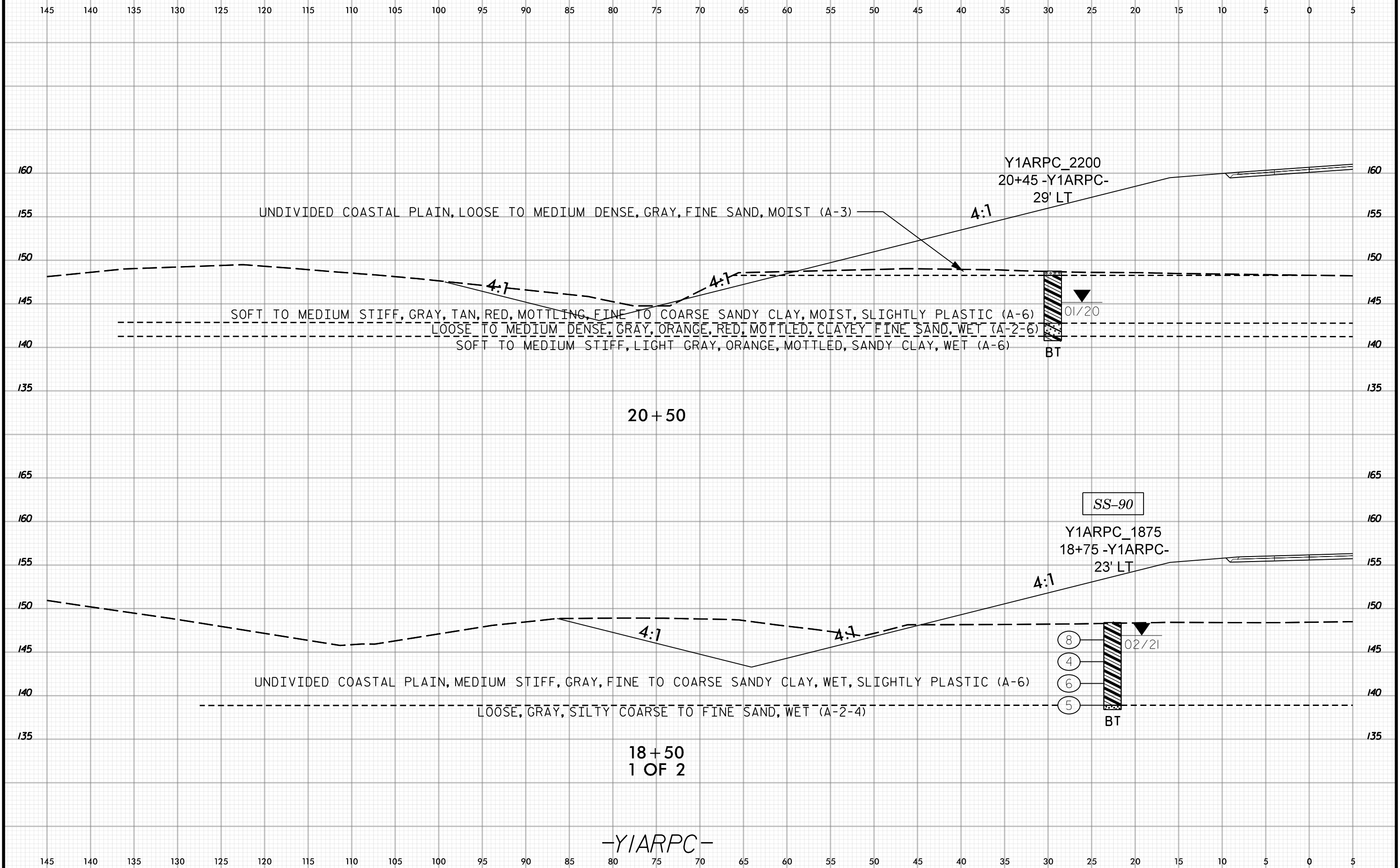

UNDIVIDED COASTAL PLAIN, LOOSE TO MEDIUM DENSE, GRAY, FINE SAND, MOIST (A-3)

SOFT TO MEDIUM STIFF, GRAY, TAN, RED, MOTTLING, FINE TO COARSE SANDY CLAY, MOIST, SLIGHTLY PLASTIC (A-6)

LOOSE TO MEDIUM DENSE, GRAY, ORANGE, RED, MOTTLED, CLAYEY FINE SAND, WET (A-2-6)

SOFT TO MEDIUM STIFF, LIGHT GRAY, ORANGE, MOTTLED, SANDY CLAY, WET (A-6)

UNDIVIDED COASTAL PLAIN, MEDIUM STIFF, GRAY, FINE TO COARSE SANDY CLAY, WET, SLIGHTLY PLASTIC (A-6)

LOOSE, GRAY, SILTY COARSE TO FINE SAND, WET (A-2-4)

20+50

18+50  
1 OF 2

-YIARPC-

Y1ARPC\_2200  
20+45 -Y1ARPC-  
29' LT

Y1ARPC\_1875  
18+75 -Y1ARPC-  
23' LT

SS-90

- 8
- 4
- 6
- 5

4:1

4:1

4:1

4:1

4:1

01/20

02/21

BT

BT



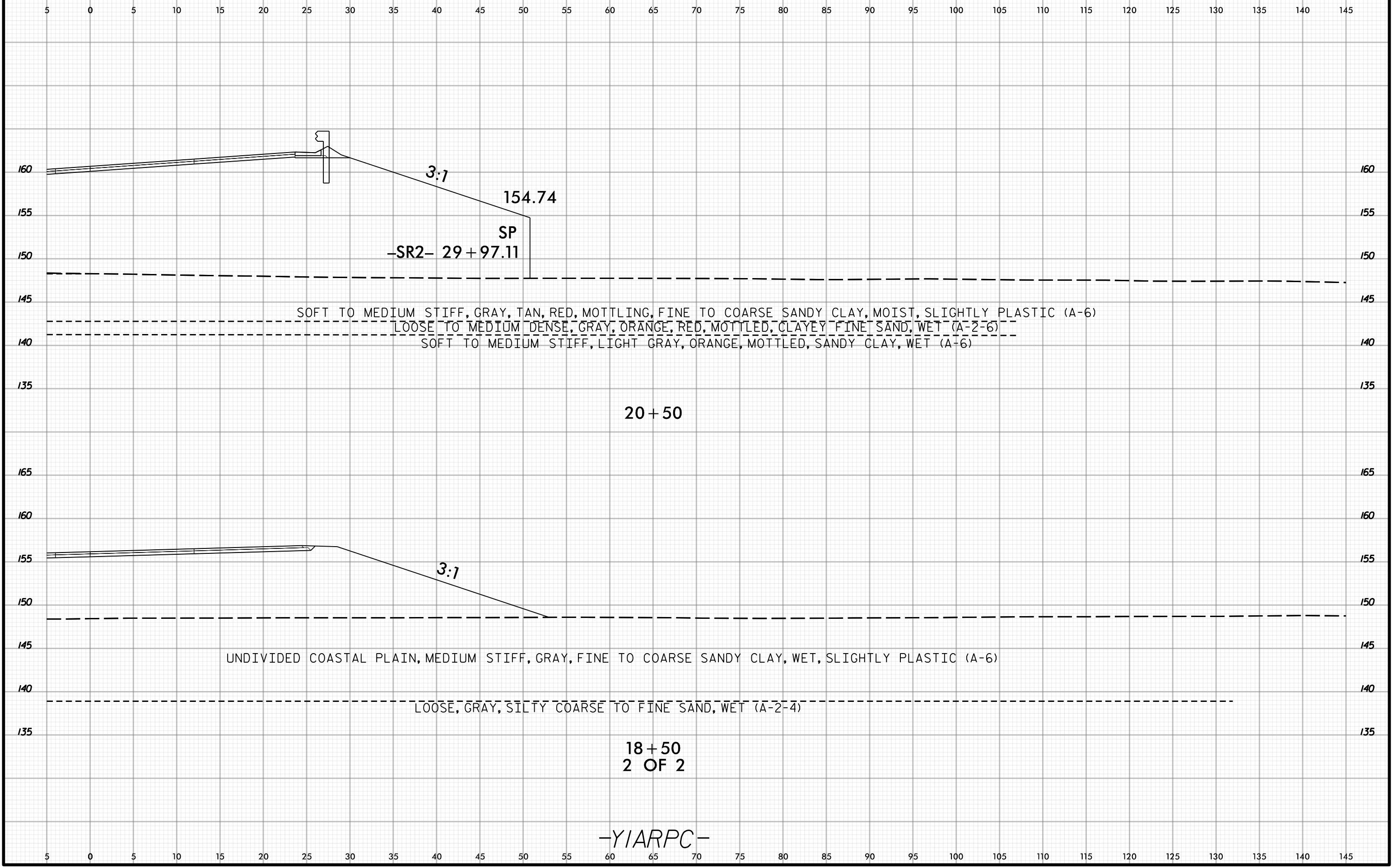

-YIARPC-

18+50  
2 OF 2

20+50

-SR2- 29+97.11

SP

3:1

154.74

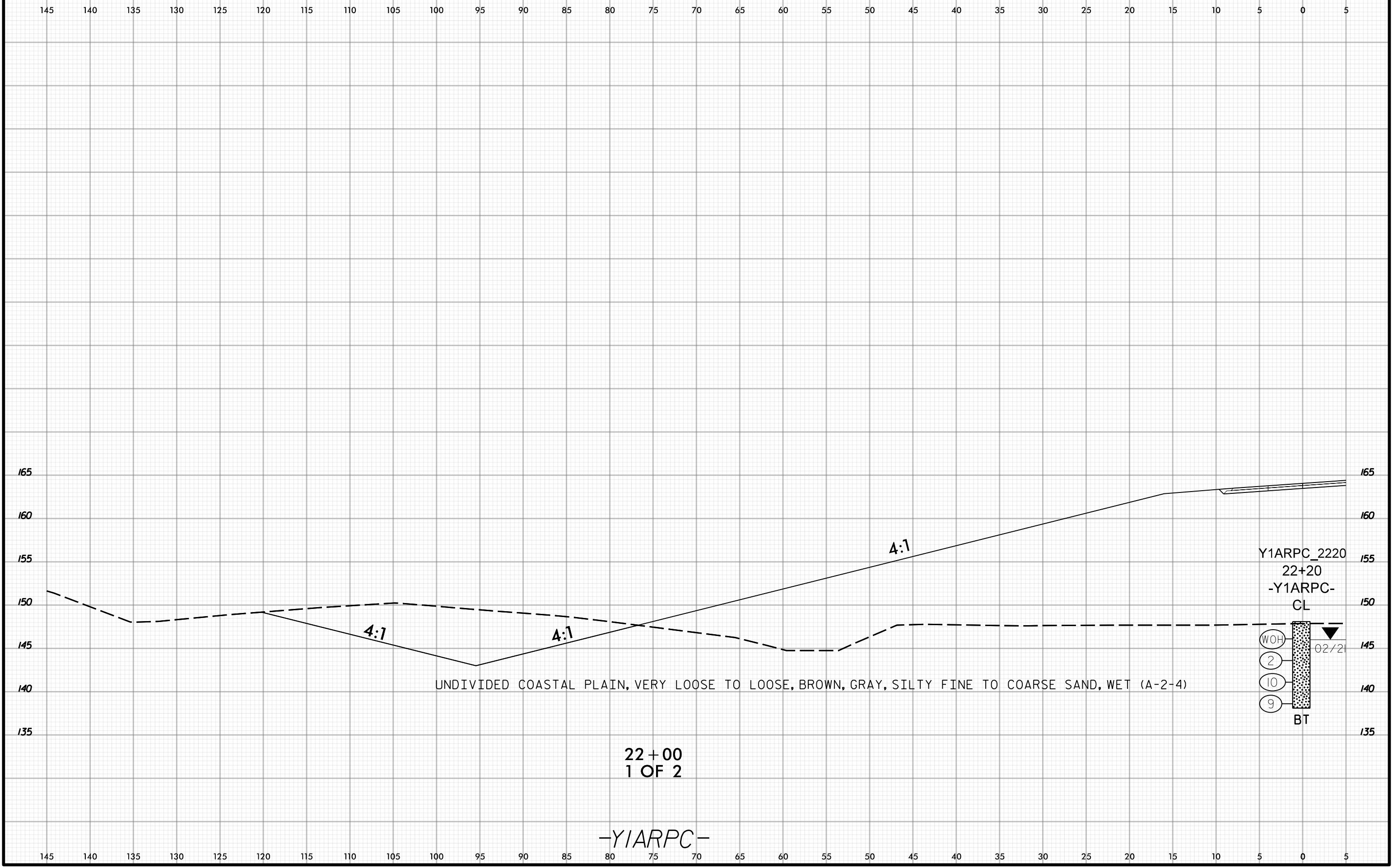
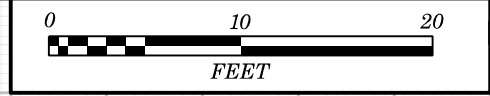

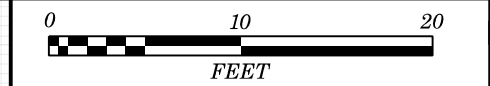

5 0 5 10 15 20 25 30 35 40 45 50 55 60 65 70 75 80 85 90 95 100 105 110 115 120 125 130 135 140 145

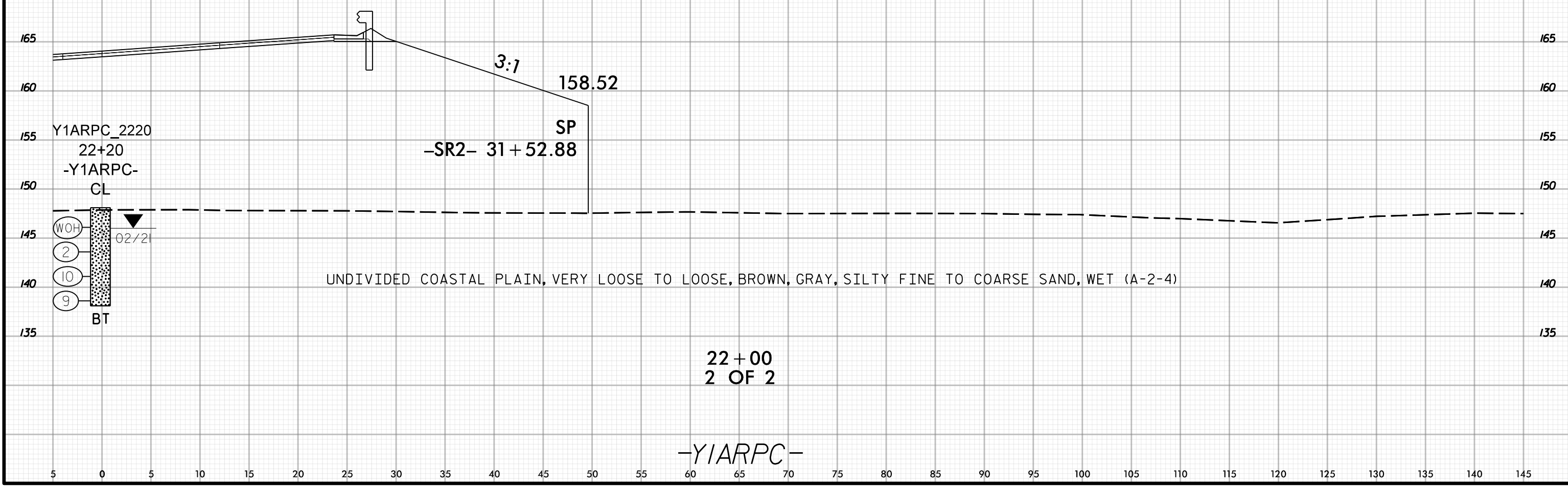

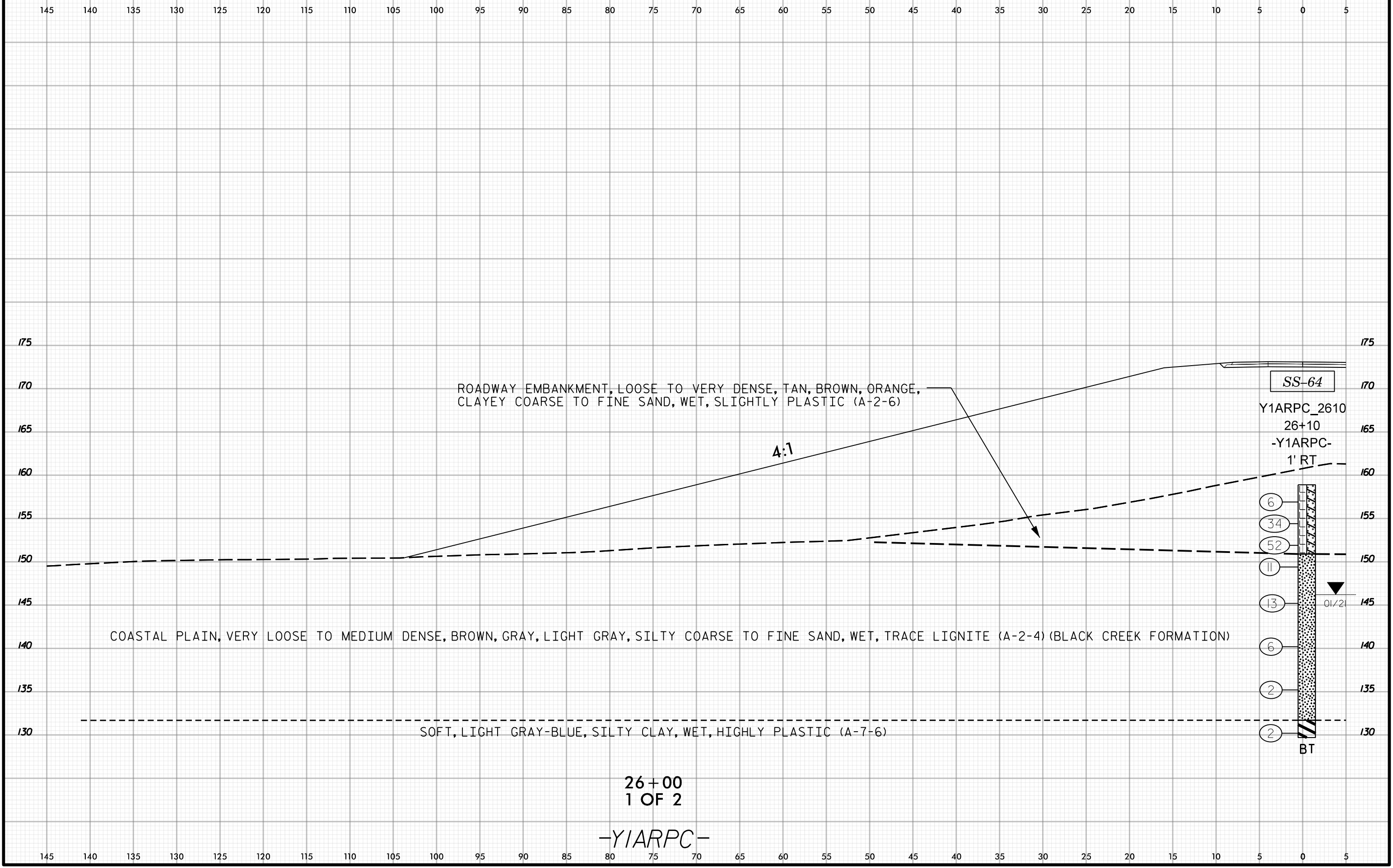
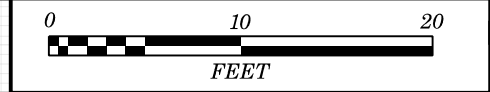



5 0 5 10 15 20 25 30 35 40 45 50 55 60 65 70 75 80 85 90 95 100 105 110 115 120 125 130 135 140 145

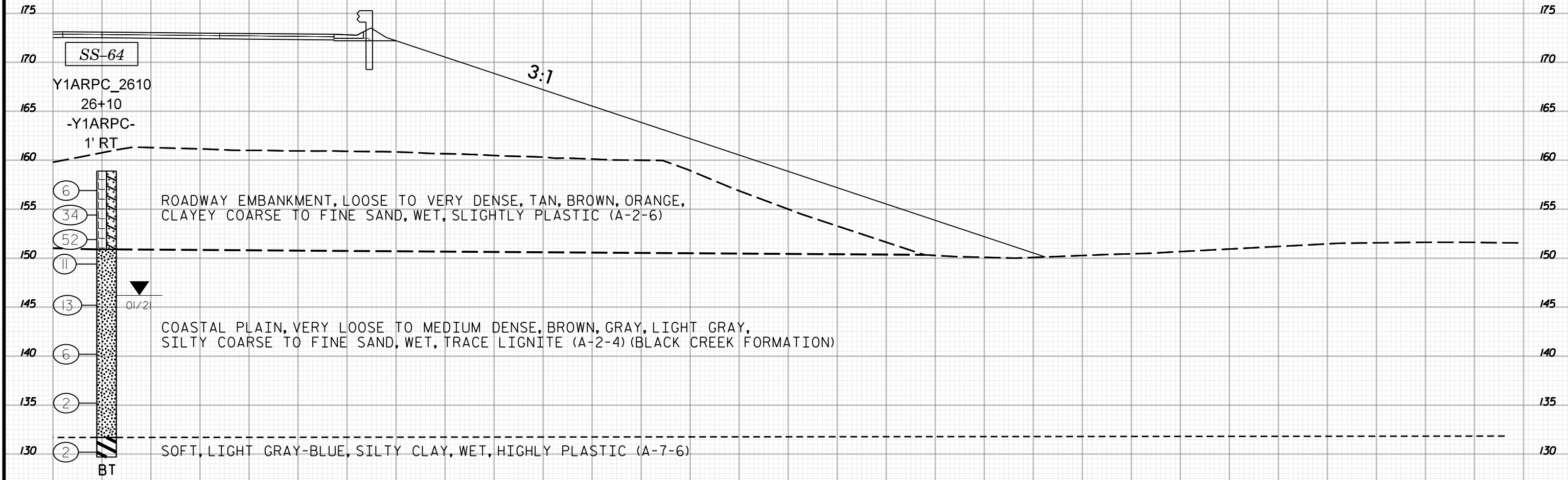

26+00  
2 OF 2  
-Y1ARPC-

5 0 5 10 15 20 25 30 35 40 45 50 55 60 65 70 75 80 85 90 95 100 105 110 115 120 125 130 135 140 145

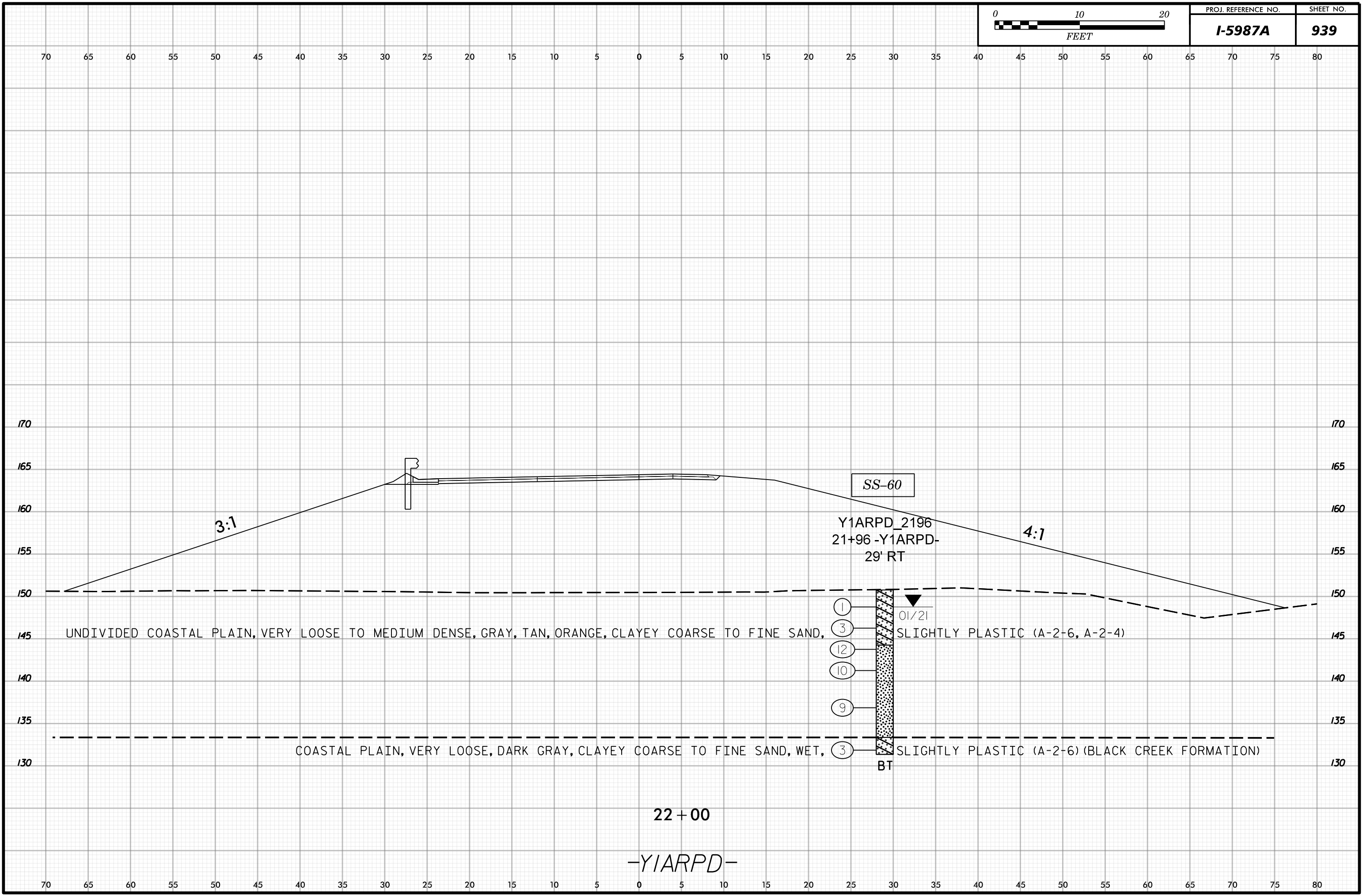

3:1

4:1

SS-60

Y1ARPD\_2196  
21+96 -Y1ARPD-  
29' RT

- ①
- ③
- ⑫
- ⑩
- ⑨
- ③

01/21  
SLIGHTLY PLASTIC (A-2-6, A-2-4)

BT  
SLIGHTLY PLASTIC (A-2-6) (BLACK CREEK FORMATION)

UNDIVIDED COASTAL PLAIN, VERY LOOSE TO MEDIUM DENSE, GRAY, TAN, ORANGE, CLAYEY COARSE TO FINE SAND,

COASTAL PLAIN, VERY LOOSE, DARK GRAY, CLAYEY COARSE TO FINE SAND, WET,

22+00

-Y1ARPD-

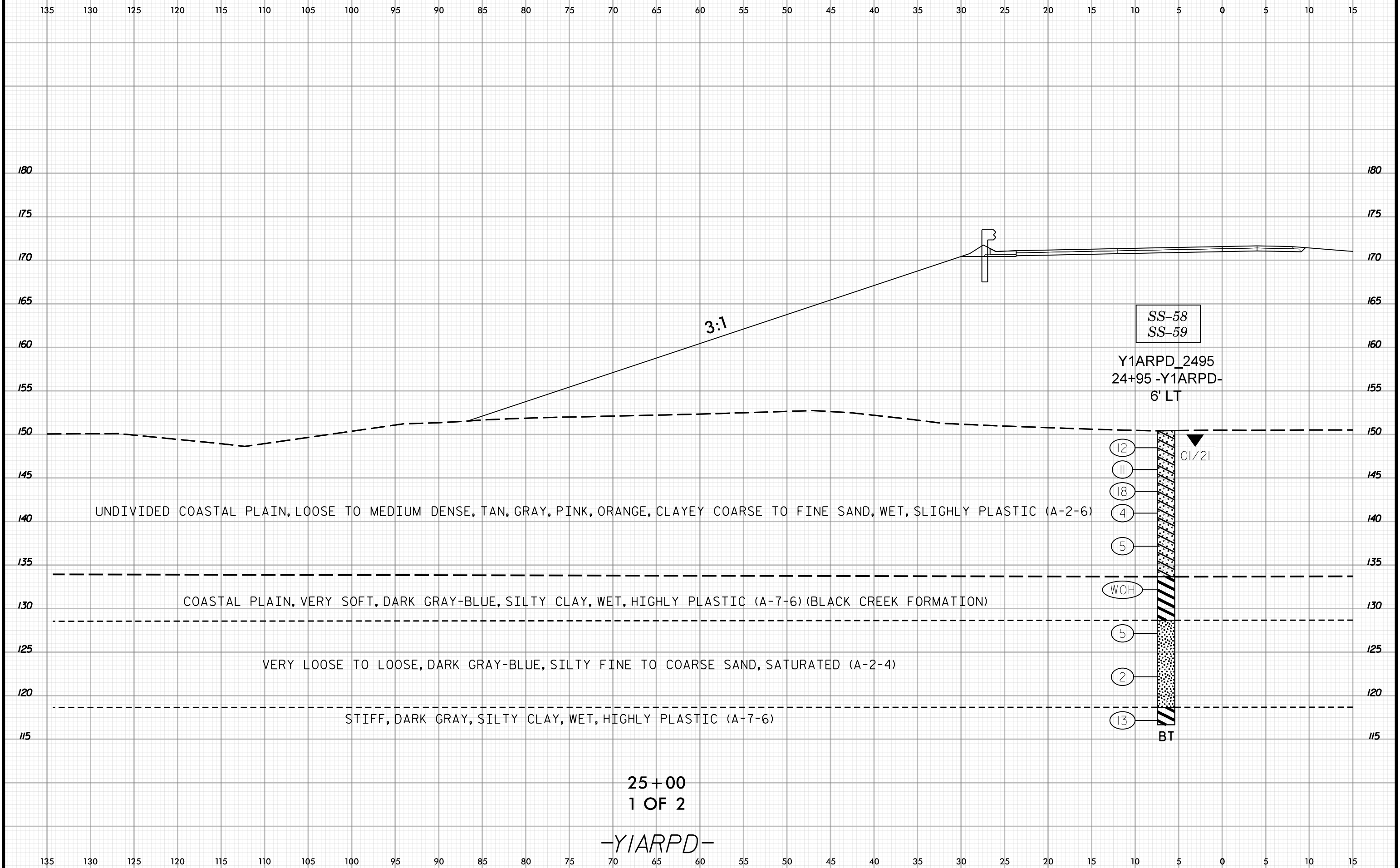

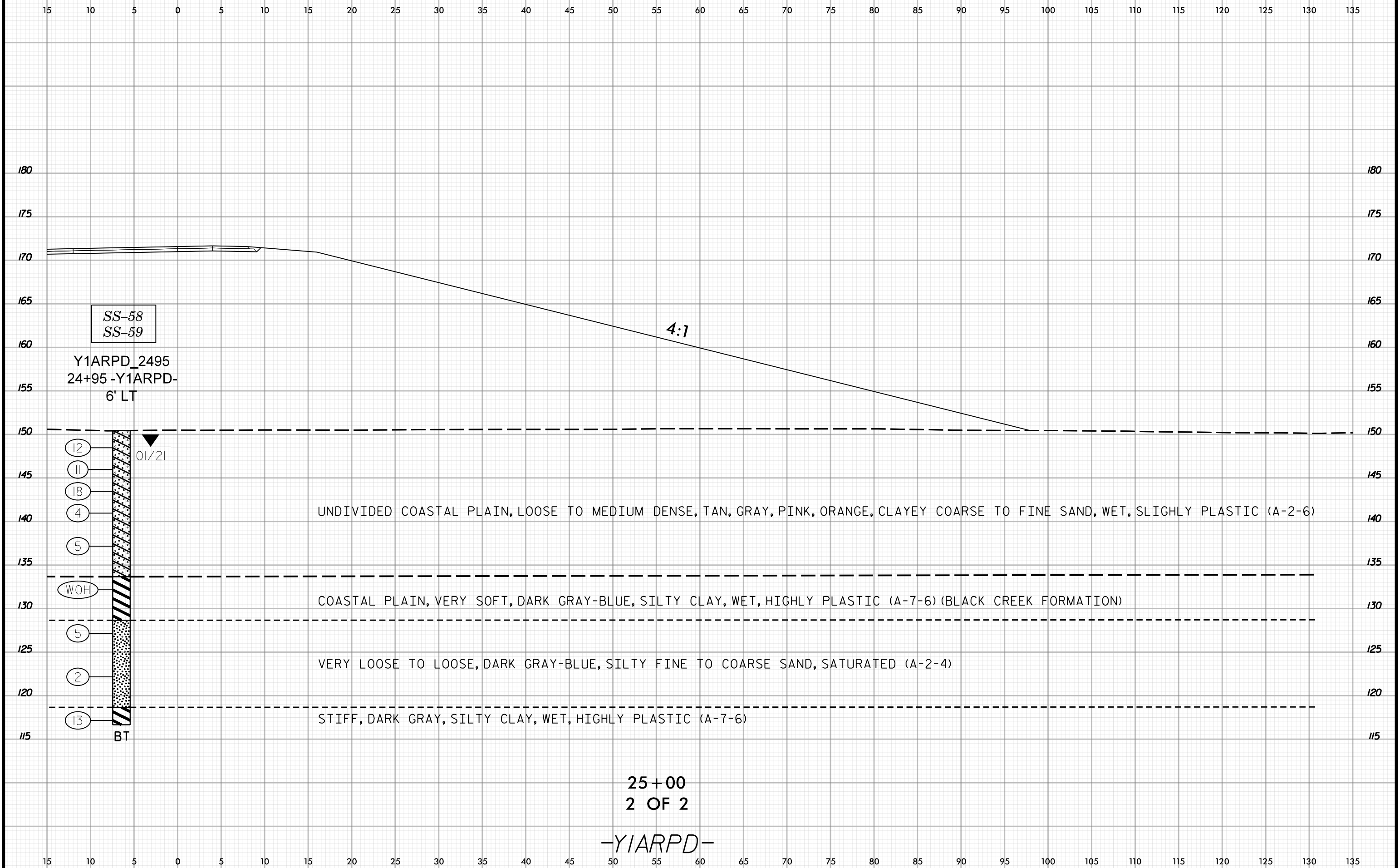
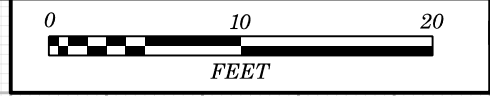

SS-58  
SS-59

Y1ARPD\_2495  
24+95 -Y1ARPD-  
6' LT

01/21

4:1

UNDIVIDED COASTAL PLAIN, LOOSE TO MEDIUM DENSE, TAN, GRAY, PINK, ORANGE, CLAYEY COARSE TO FINE SAND, WET, SLIGHTLY PLASTIC (A-2-6)

COASTAL PLAIN, VERY SOFT, DARK GRAY-BLUE, SILTY CLAY, WET, HIGHLY PLASTIC (A-7-6) (BLACK CREEK FORMATION)

VERY LOOSE TO LOOSE, DARK GRAY-BLUE, SILTY FINE TO COARSE SAND, SATURATED (A-2-4)

STIFF, DARK GRAY, SILTY CLAY, WET, HIGHLY PLASTIC (A-7-6)

25+00  
2 OF 2

-Y1ARPD-



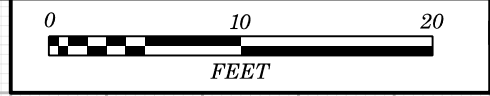

PROJ. REFERENCE NO.	SHEET NO.
I-5987A	942

145 140 135 130 125 120 115 110 105 100 95 90 85 80 75 70 65 60 55 50 45 40 35 30 25 20 15 10 5 0 5

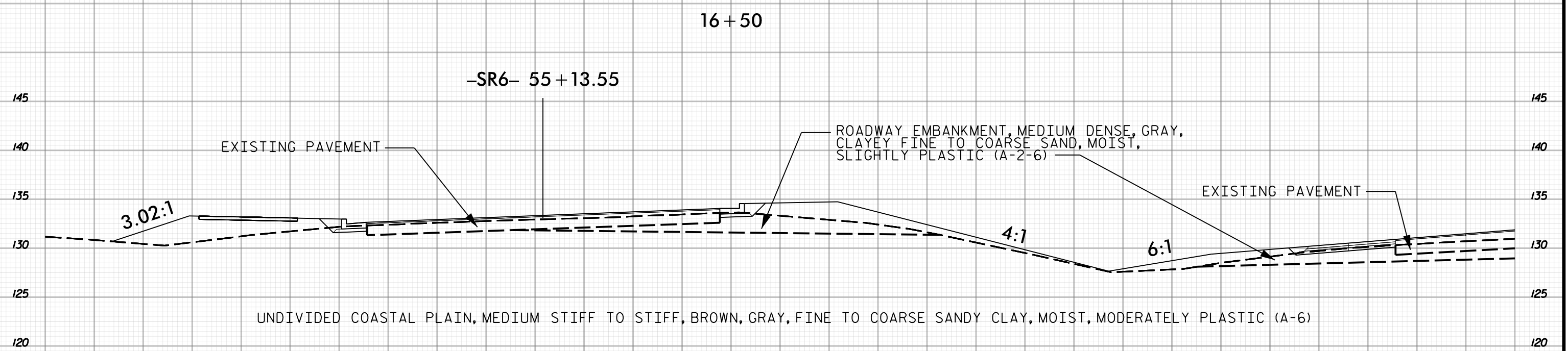
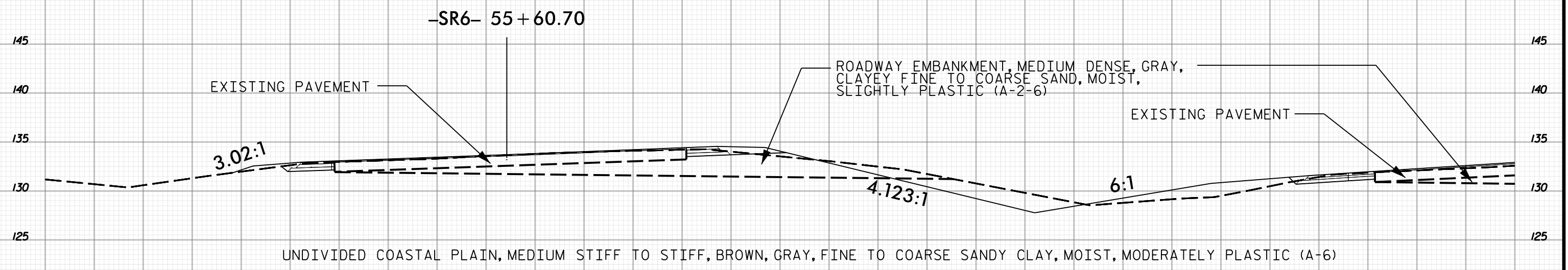

16 + 50

16 + 00  
1 OF 2

-YIRPB-

145 140 135 130 125 120 115 110 105 100 95 90 85 80 75 70 65 60 55 50 45 40 35 30 25 20 15 10 5 0 5



5 0 5 10 15 20 25 30 35 40 45 50 55 60 65 70 75 80 85 90 95 100 105 110 115 120 125 130 135 140 145

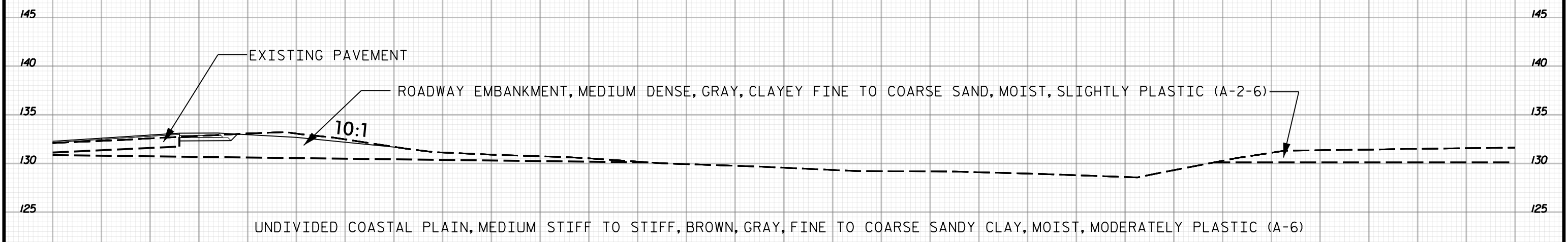

16+50

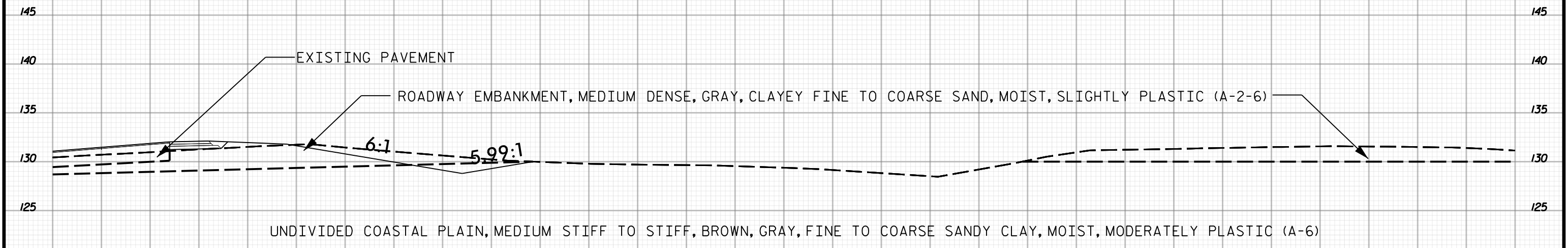

16+00  
2 OF 2

-YIRPB-

5 0 5 10 15 20 25 30 35 40 45 50 55 60 65 70 75 80 85 90 95 100 105 110 115 120 125 130 135 140 145

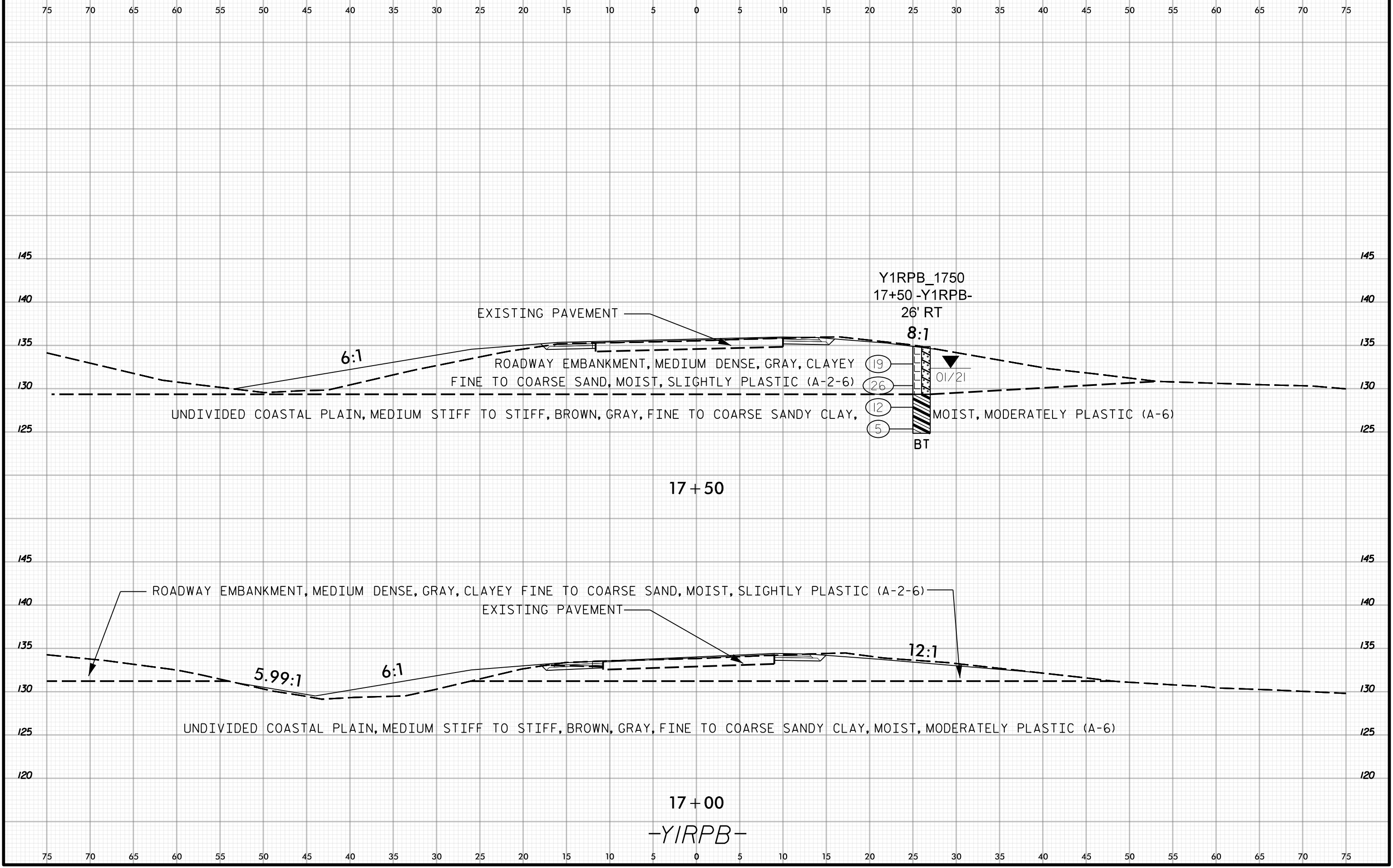

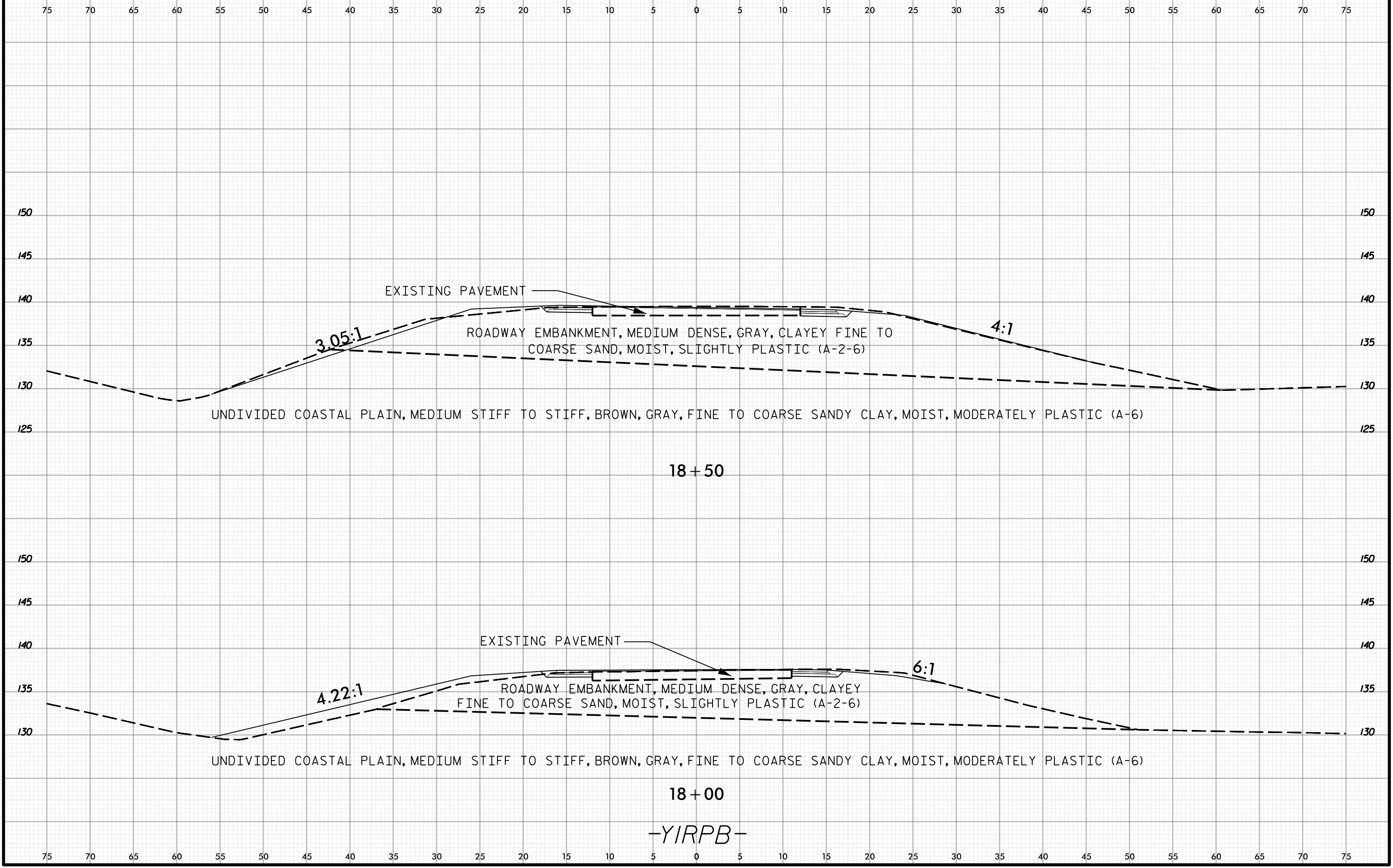

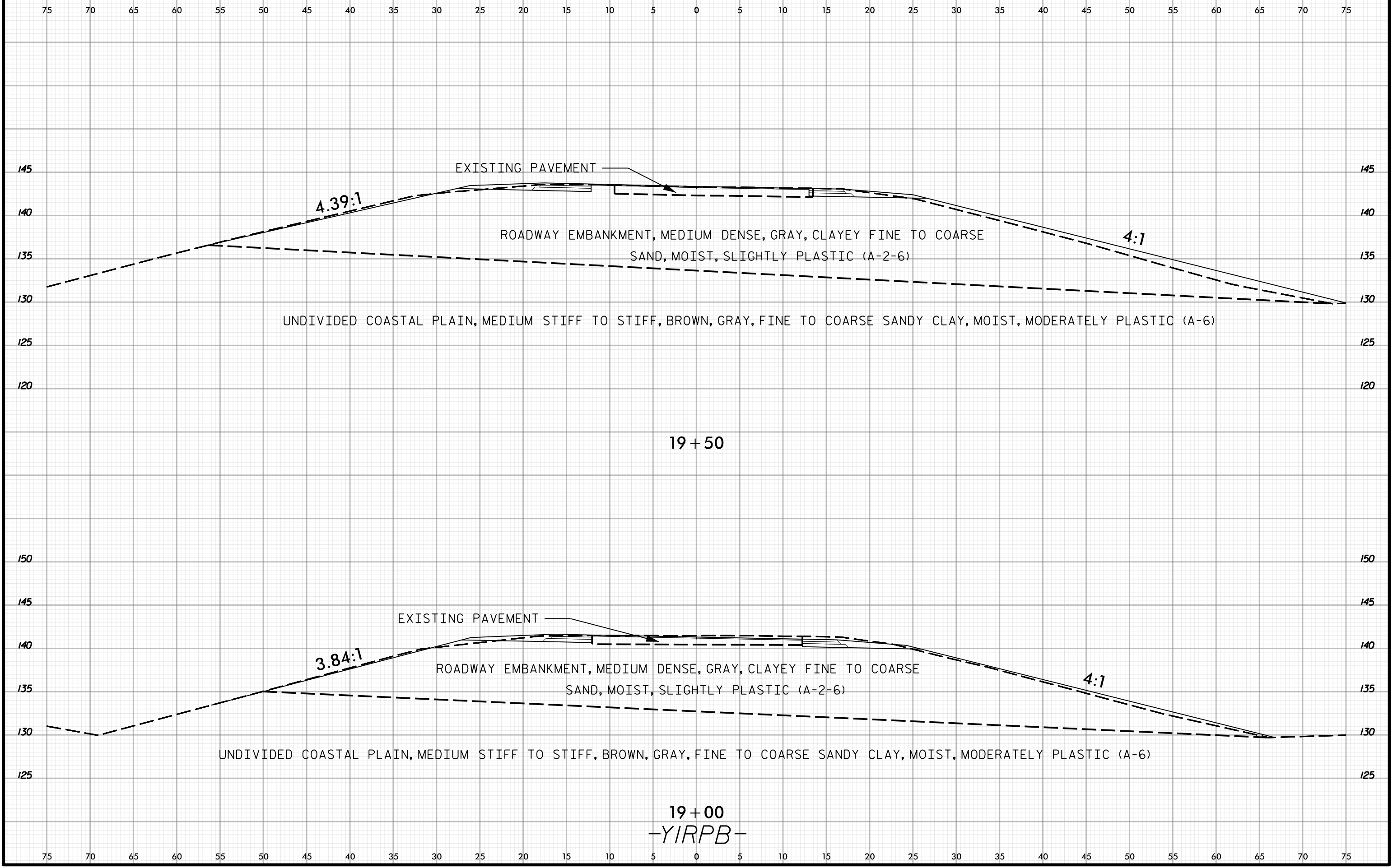

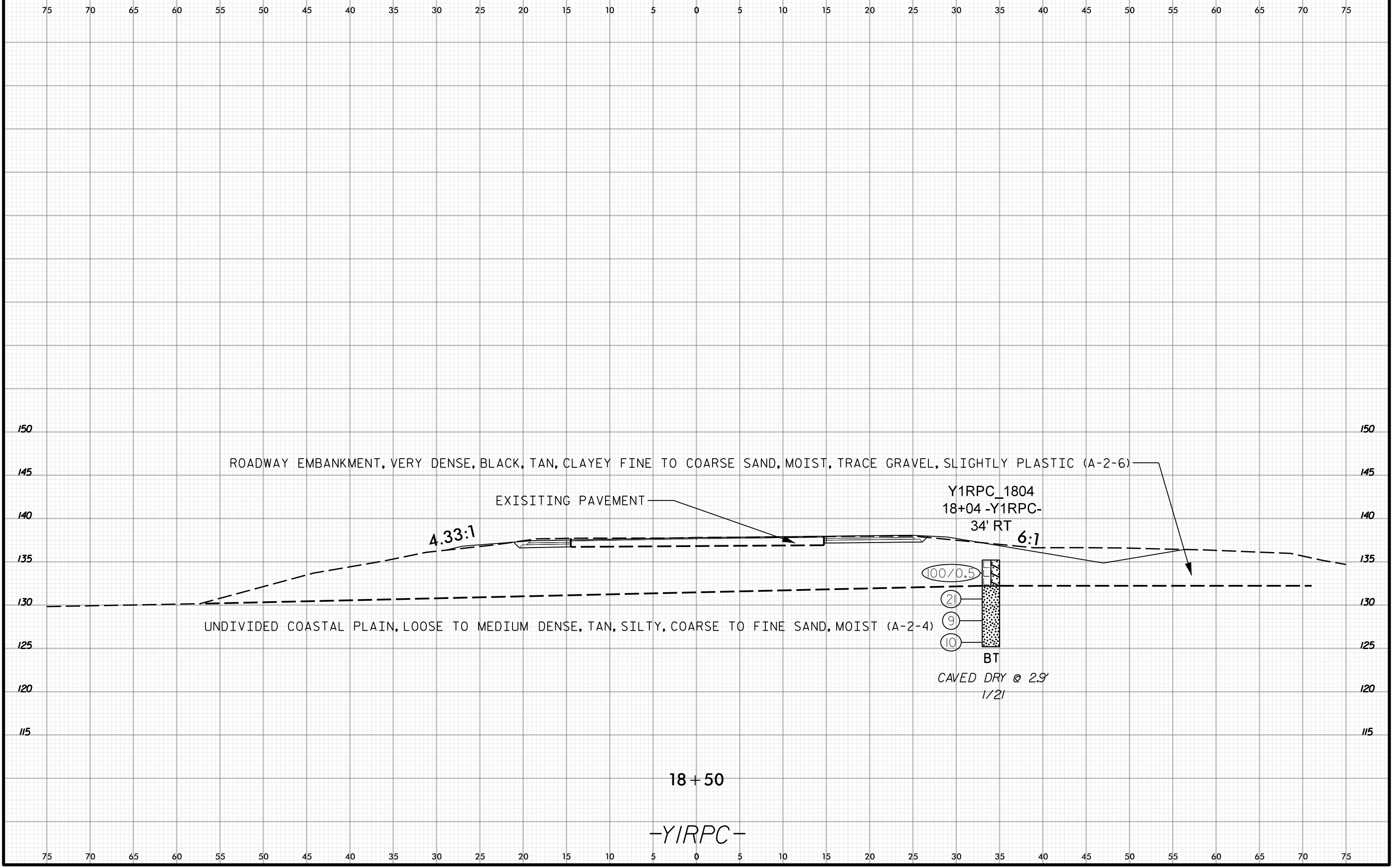



75 70 65 60 55 50 45 40 35 30 25 20 15 10 5 0 5 10 15 20 25 30 35 40 45 50 55 60 65 70 75

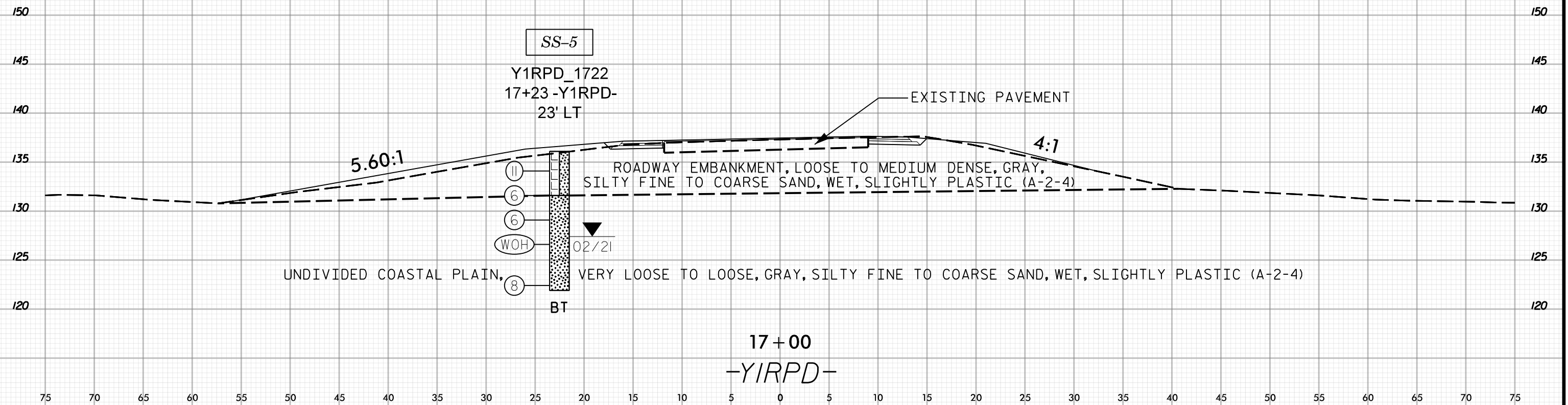



PROJ. REFERENCE NO.	SHEET NO.
I-5987A	949

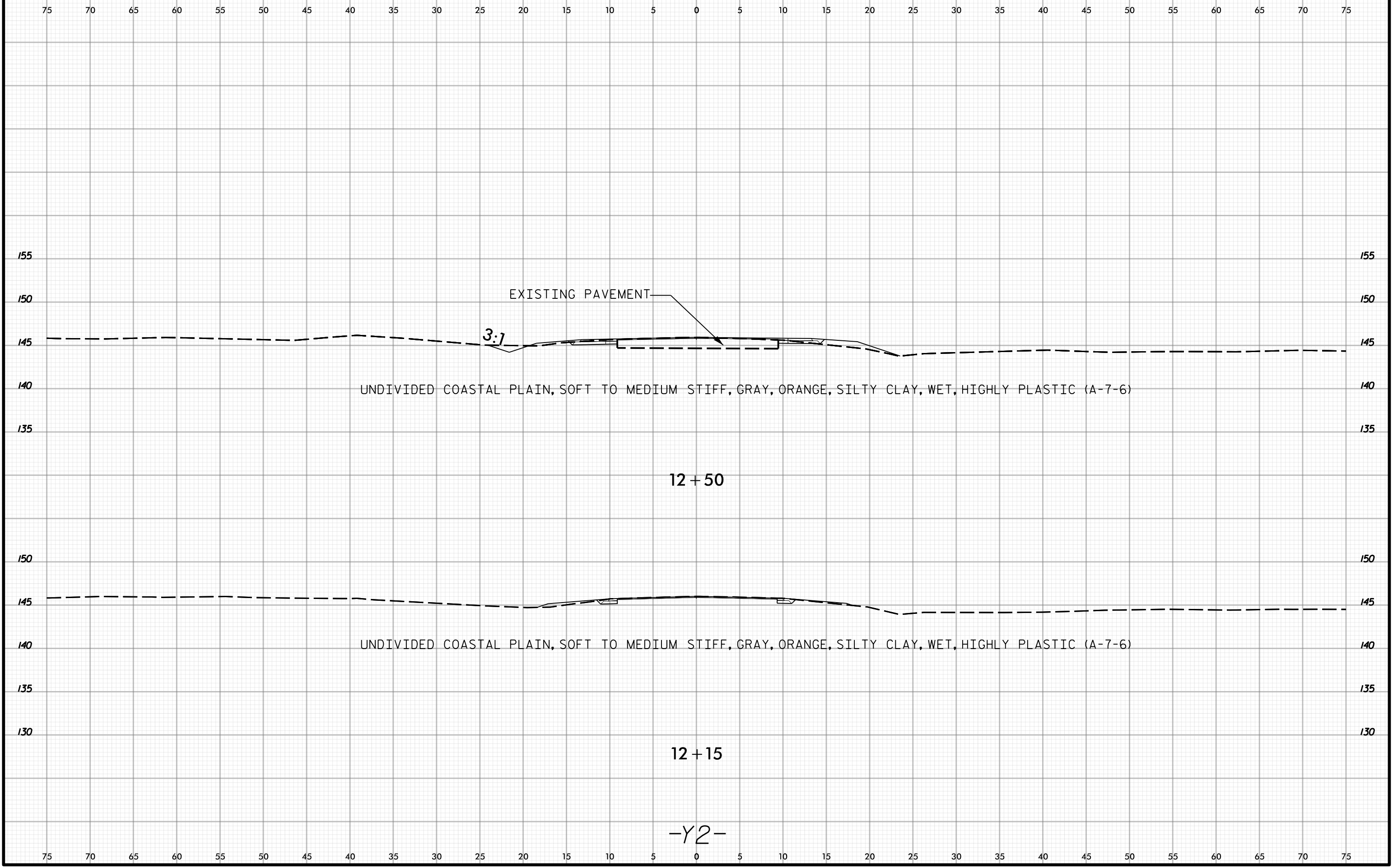

3:1

EXISTING PAVEMENT

UNDIVIDED COASTAL PLAIN, SOFT TO MEDIUM STIFF, GRAY, ORANGE, SILTY CLAY, WET, HIGHLY PLASTIC (A-7-6)

12+50

UNDIVIDED COASTAL PLAIN, SOFT TO MEDIUM STIFF, GRAY, ORANGE, SILTY CLAY, WET, HIGHLY PLASTIC (A-7-6)

12+15

-Y2-





PROJ. REFERENCE NO.	SHEET NO.
I-5987A	950

75 70 65 60 55 50 45 40 35 30 25 20 15 10 5 0 5 10 15 20 25 30 35 40 45 50 55 60 65 70 75

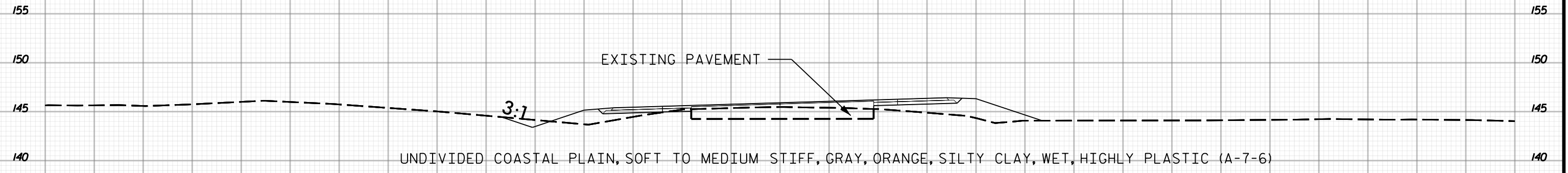

13+50

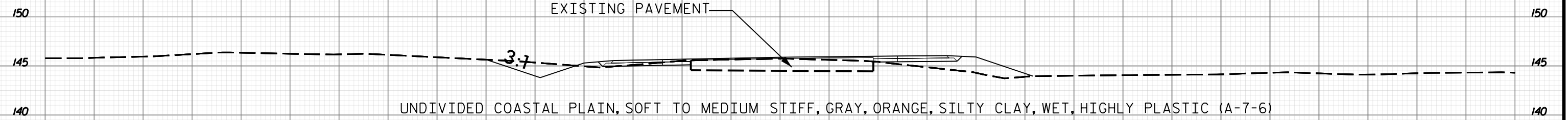

13+00

-Y2-

75 70 65 60 55 50 45 40 35 30 25 20 15 10 5 0 5 10 15 20 25 30 35 40 45 50 55 60 65 70 75



PROJ. REFERENCE NO.	SHEET NO.
I-5987A	951

75 70 65 60 55 50 45 40 35 30 25 20 15 10 5 0 5 10 15 20 25 30 35 40 45 50 55 60 65 70 75



75 70 65 60 55 50 45 40 35 30 25 20 15 10 5 0 5 10 15 20 25 30 35 40 45 50 55 60 65 70 75



75 70 65 60 55 50 45 40 35 30 25 20 15 10 5 0 5 10 15 20 25 30 35 40 45 50 55 60 65 70 75

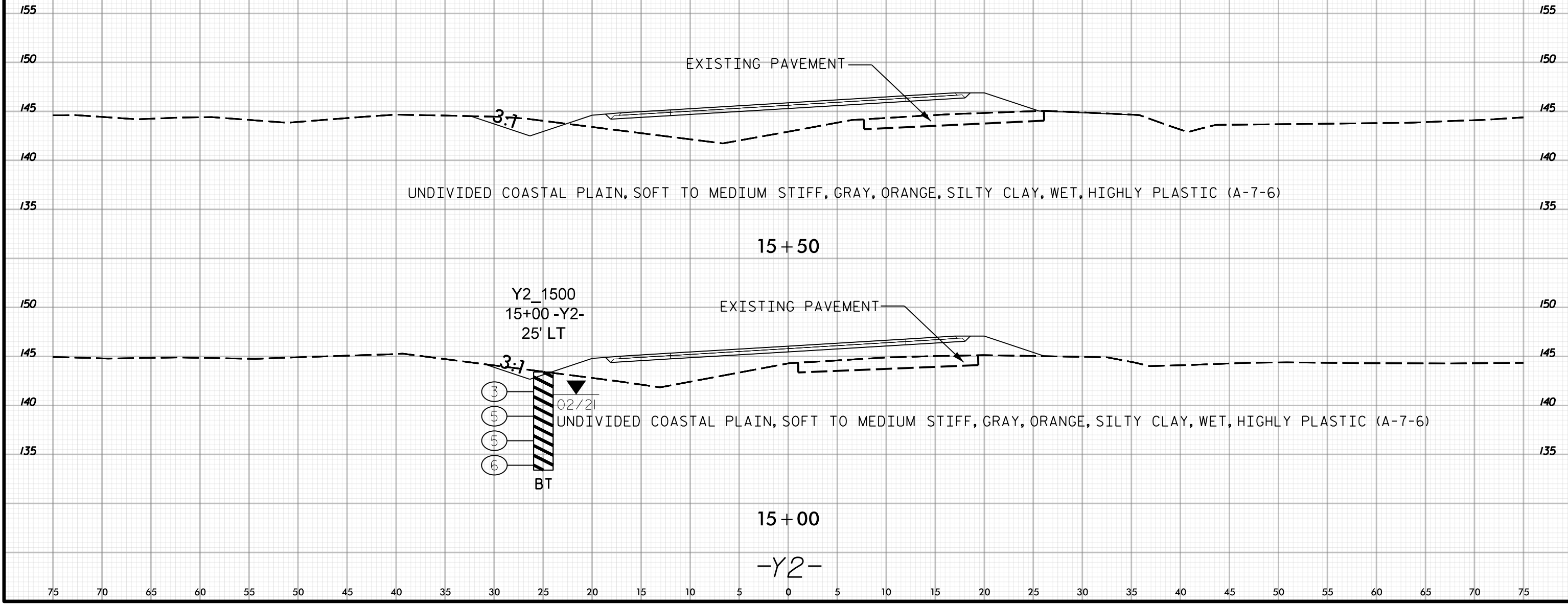

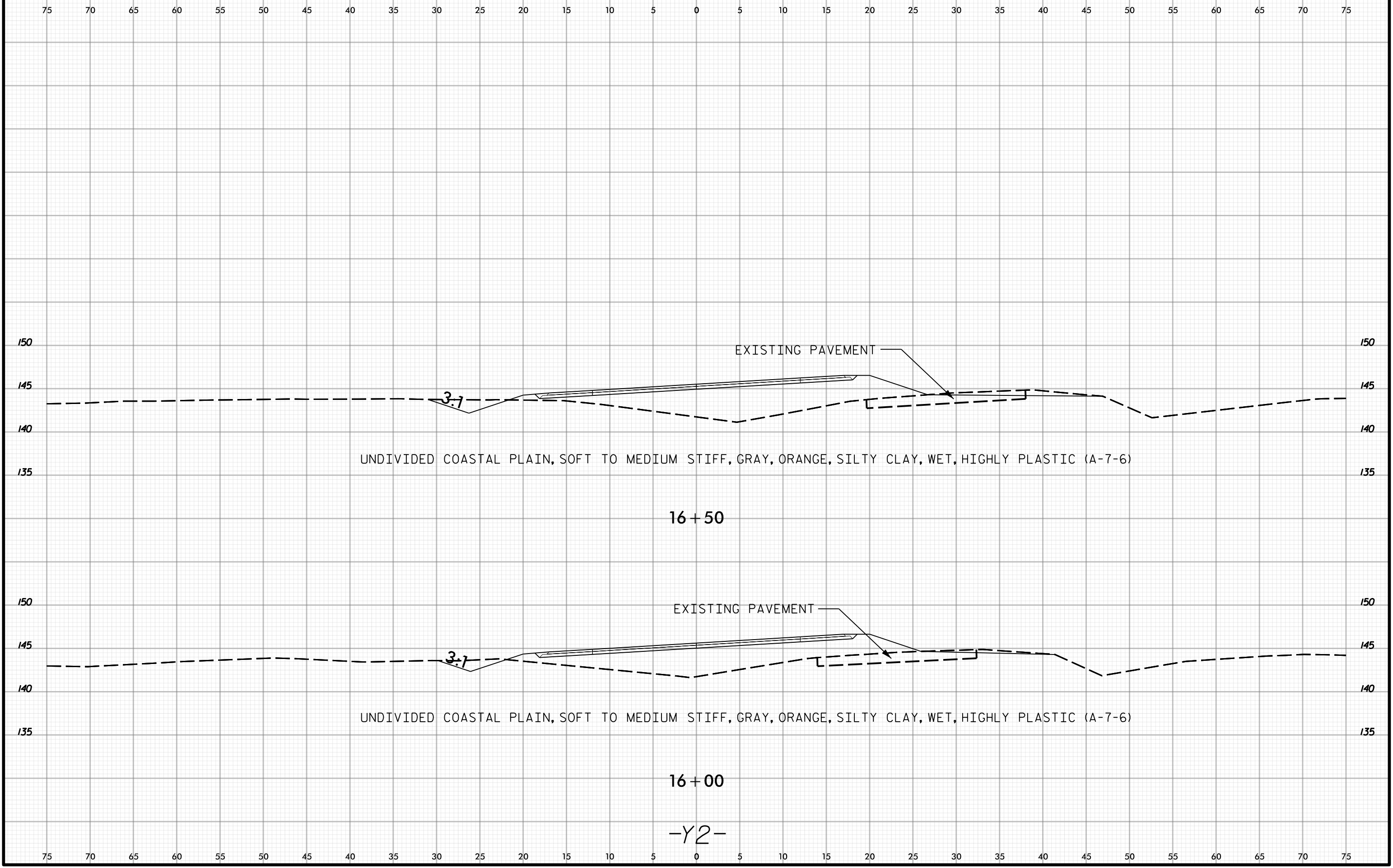



75 70 65 60 55 50 45 40 35 30 25 20 15 10 5 0 5 10 15 20 25 30 35 40 45 50 55 60 65 70 75

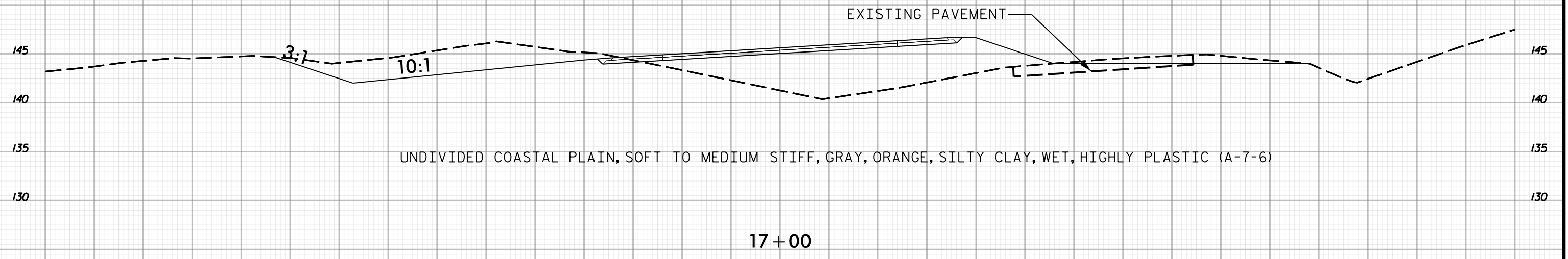
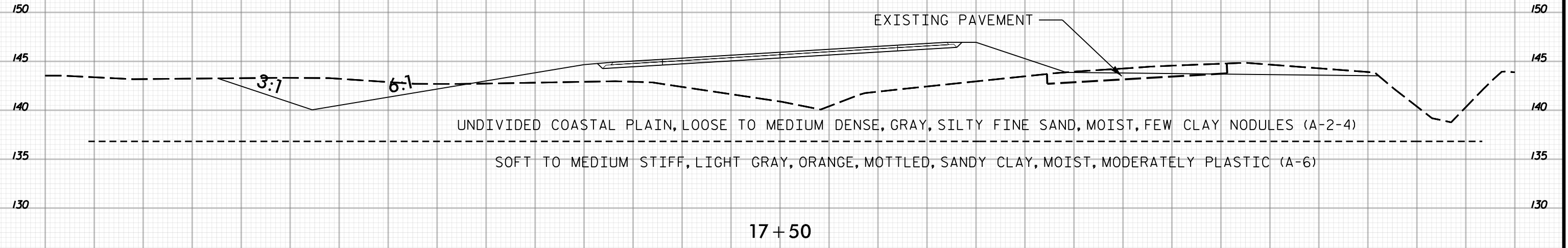

75 70 65 60 55 50 45 40 35 30 25 20 15 10 5 0 5 10 15 20 25 30 35 40 45 50 55 60 65 70 75



75 70 65 60 55 50 45 40 35 30 25 20 15 10 5 0 5 10 15 20 25 30 35 40 45 50 55 60 65 70 75

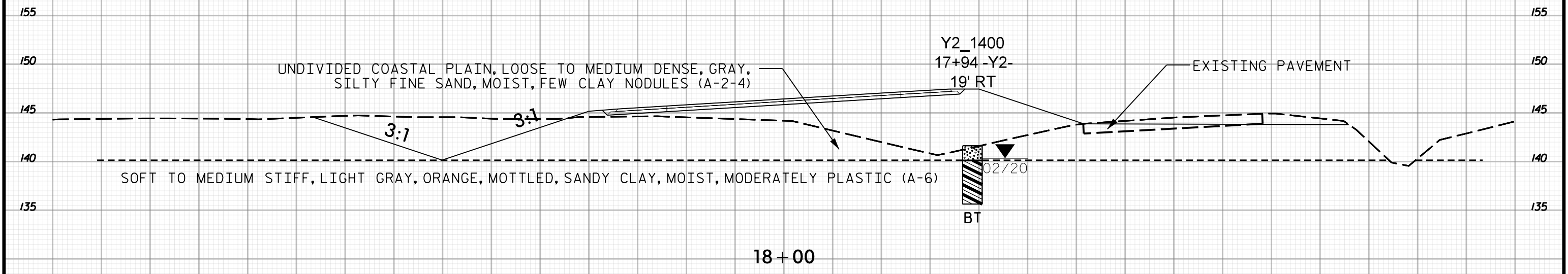
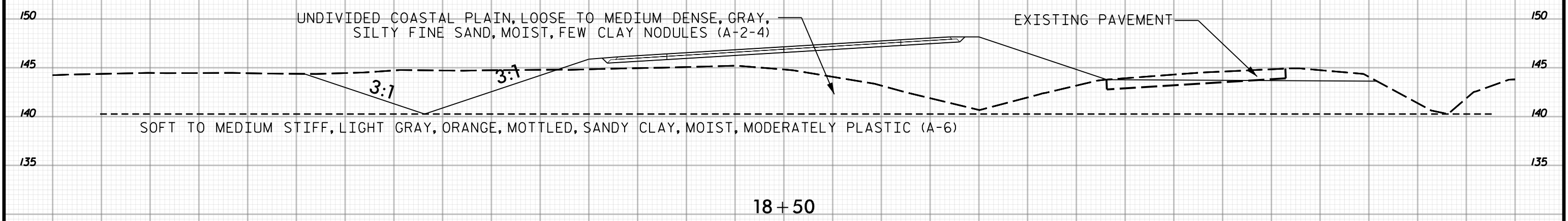

75 70 65 60 55 50 45 40 35 30 25 20 15 10 5 0 5 10 15 20 25 30 35 40 45 50 55 60 65 70 75

-Y2-

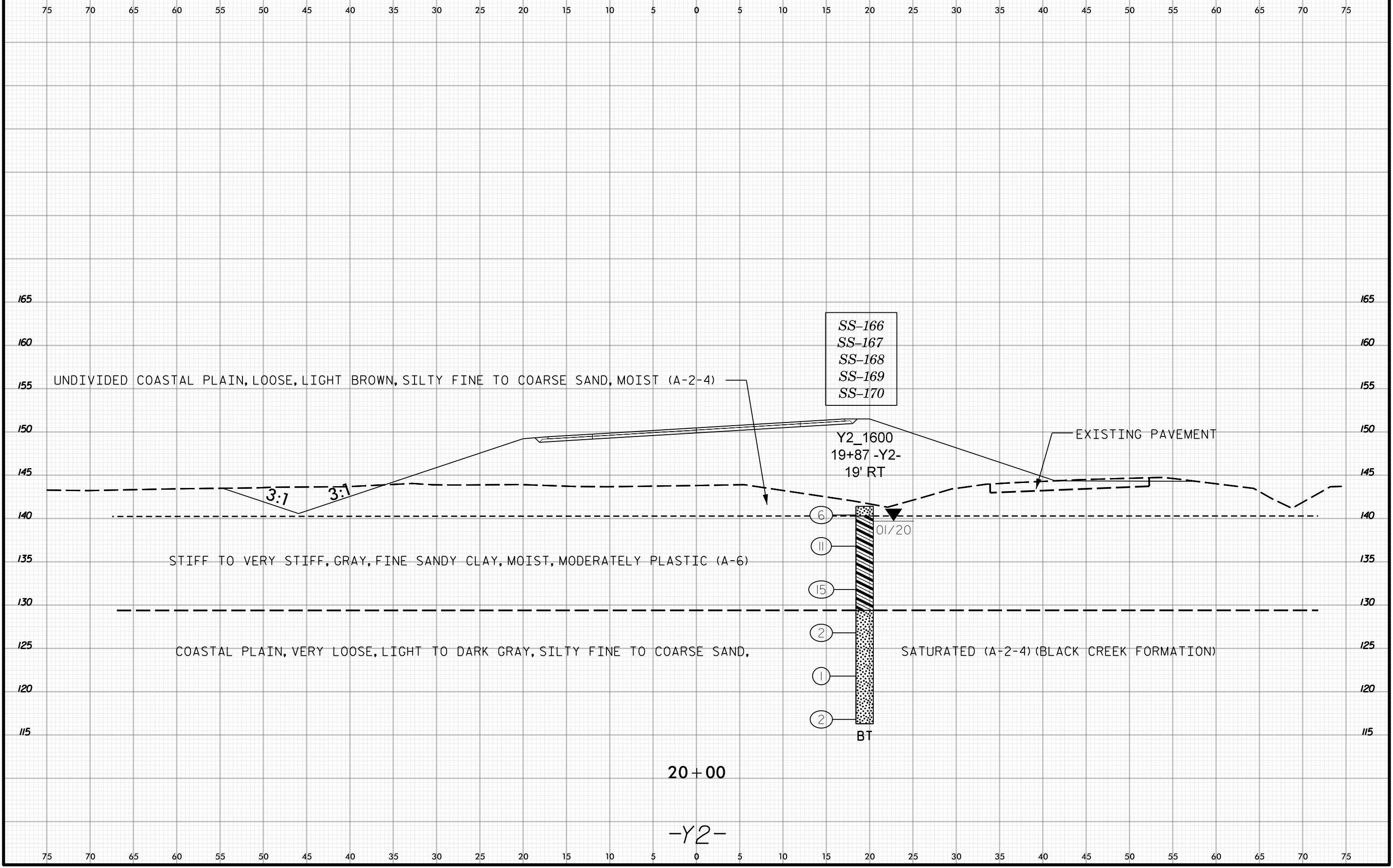
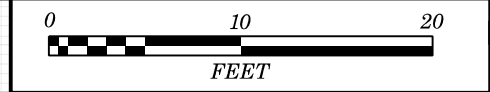

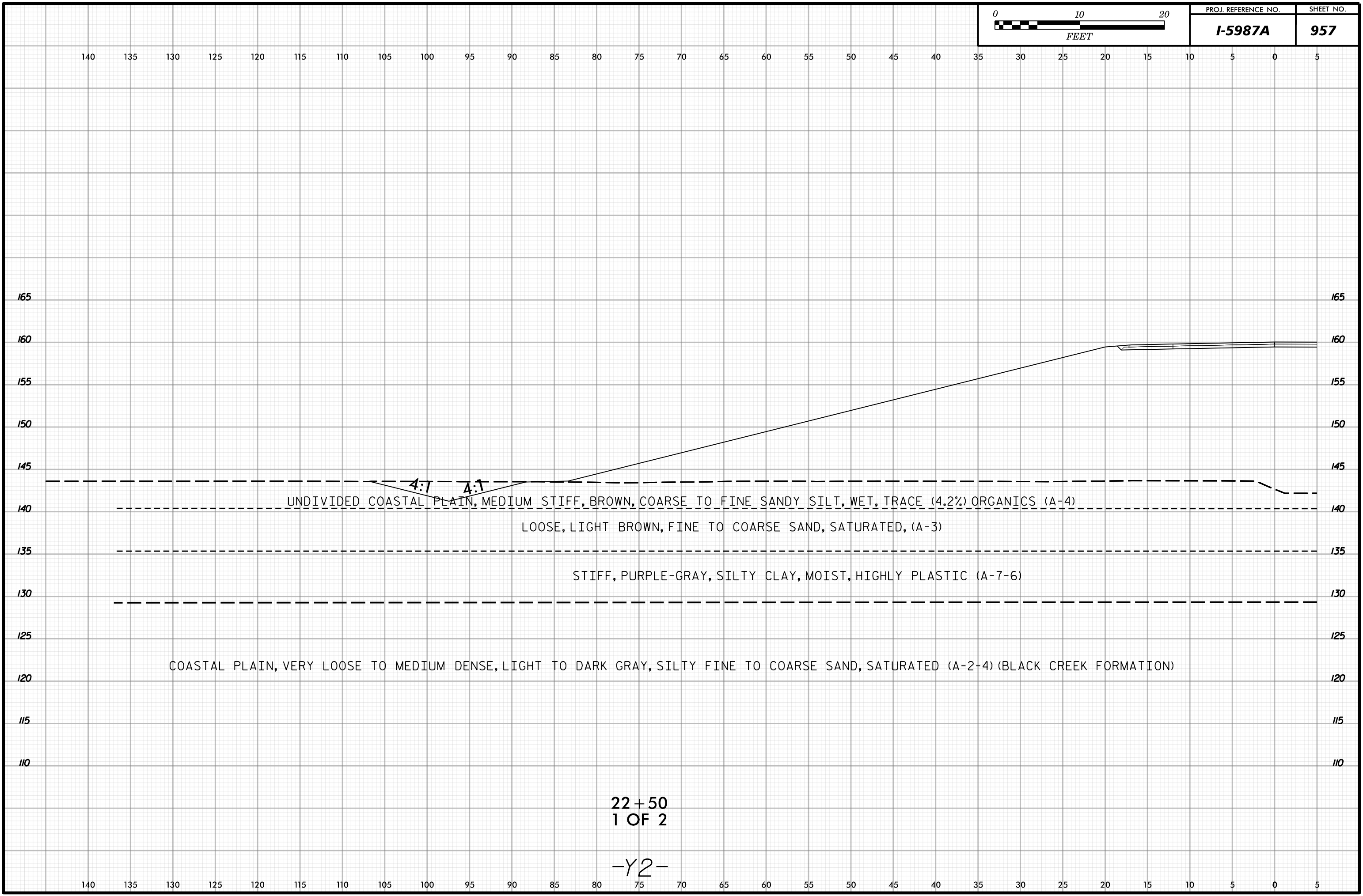

22+50  
1 OF 2

-Y2-



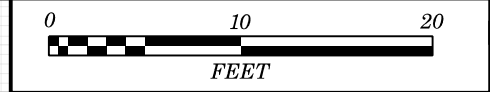

5 0 5 10 15 20 25 30 35 40 45 50 55 60 65 70 75 80 85 90 95 100 105 110 115 120 125 130 135 140 145

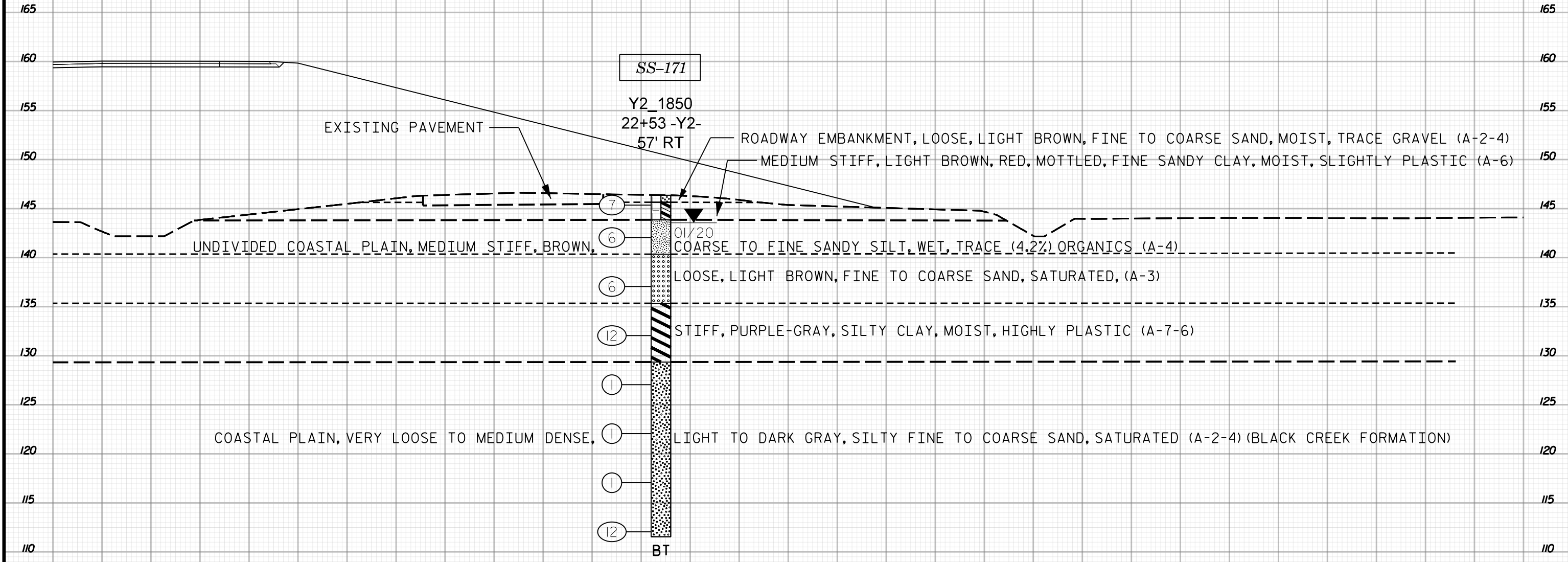

22+50  
2 OF 2

-Y2-

5 0 5 10 15 20 25 30 35 40 45 50 55 60 65 70 75 80 85 90 95 100 105 110 115 120 125 130 135 140 145

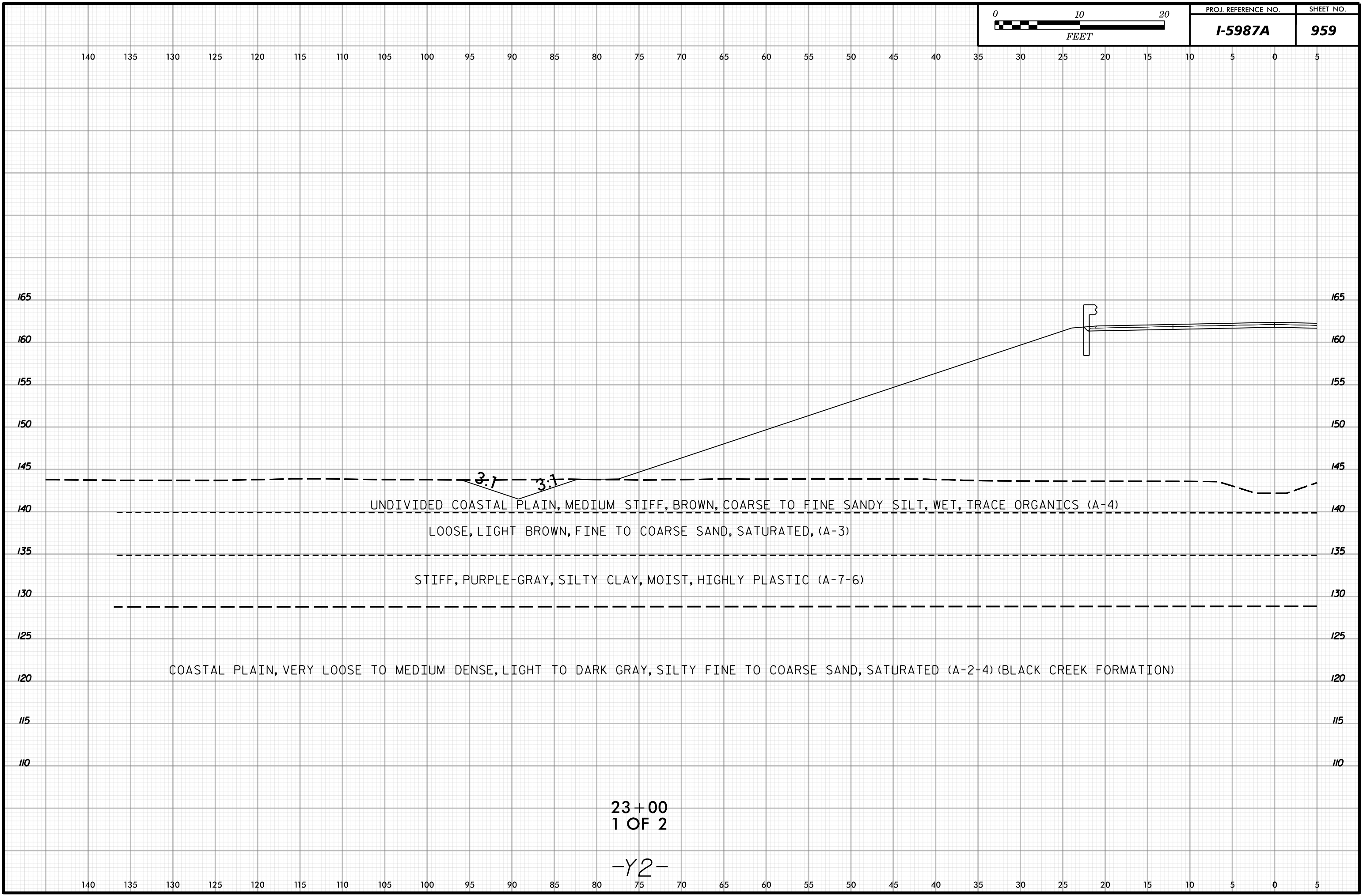

UNDIVIDED COASTAL PLAIN, MEDIUM STIFF, BROWN, COARSE TO FINE SANDY SILT, WET, TRACE ORGANICS (A-4)

LOOSE, LIGHT BROWN, FINE TO COARSE SAND, SATURATED, (A-3)

STIFF, PURPLE-GRAY, SILTY CLAY, MOIST, HIGHLY PLASTIC (A-7-6)

COASTAL PLAIN, VERY LOOSE TO MEDIUM DENSE, LIGHT TO DARK GRAY, SILTY FINE TO COARSE SAND, SATURATED (A-2-4) (BLACK CREEK FORMATION)

23+00  
1 OF 2

-Y2-

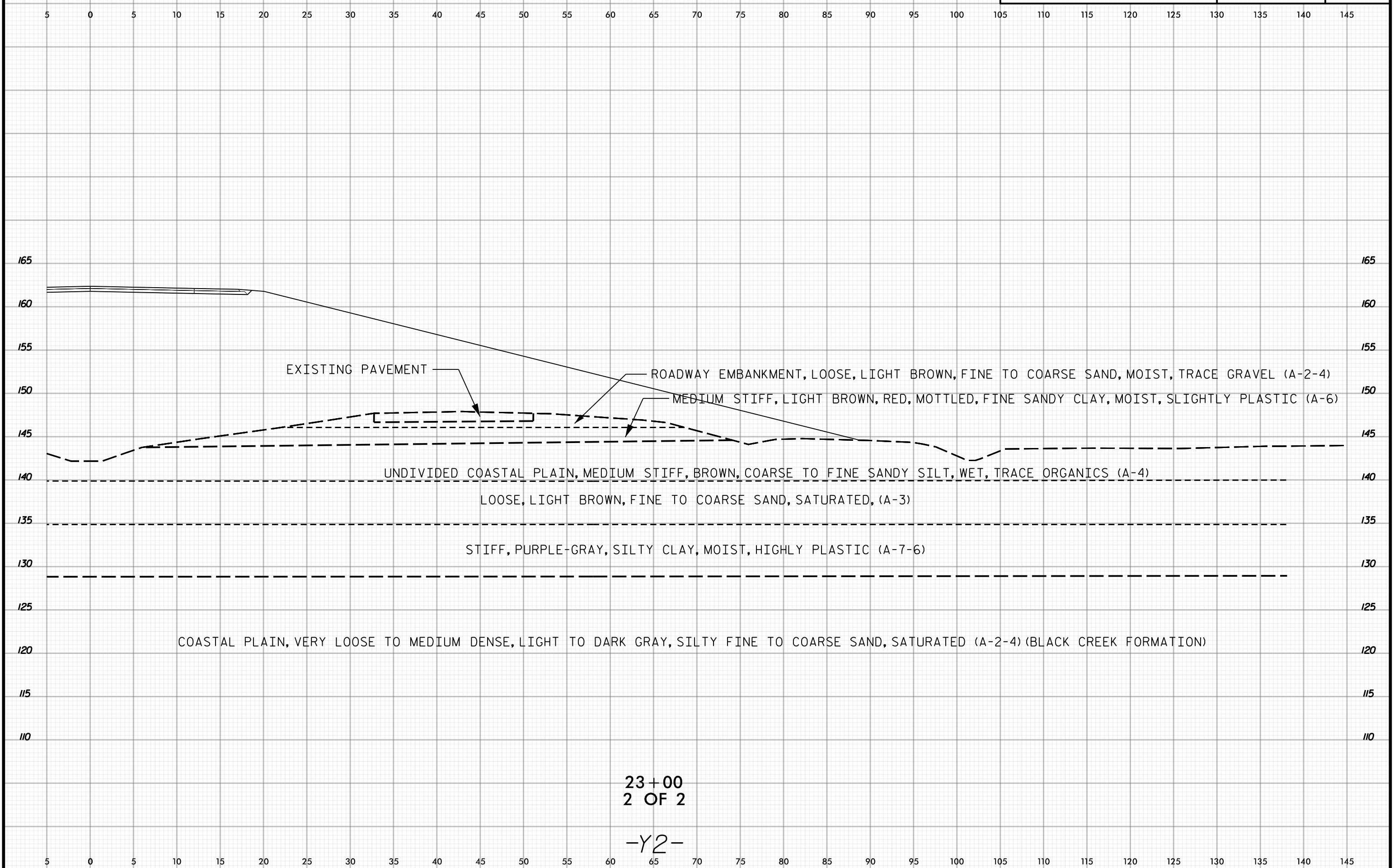

EXISTING PAVEMENT

ROADWAY EMBANKMENT, LOOSE, LIGHT BROWN, FINE TO COARSE SAND, MOIST, TRACE GRAVEL (A-2-4)

MEDIUM STIFF, LIGHT BROWN, RED, MOTTLED, FINE SANDY CLAY, MOIST, SLIGHTLY PLASTIC (A-6)

UNDIVIDED COASTAL PLAIN, MEDIUM STIFF, BROWN, COARSE TO FINE SANDY SILT, WET, TRACE ORGANICS (A-4)

LOOSE, LIGHT BROWN, FINE TO COARSE SAND, SATURATED, (A-3)

STIFF, PURPLE-GRAY, SILTY CLAY, MOIST, HIGHLY PLASTIC (A-7-6)

COASTAL PLAIN, VERY LOOSE TO MEDIUM DENSE, LIGHT TO DARK GRAY, SILTY FINE TO COARSE SAND, SATURATED (A-2-4) (BLACK CREEK FORMATION)

23+00  
2 OF 2

-Y2-

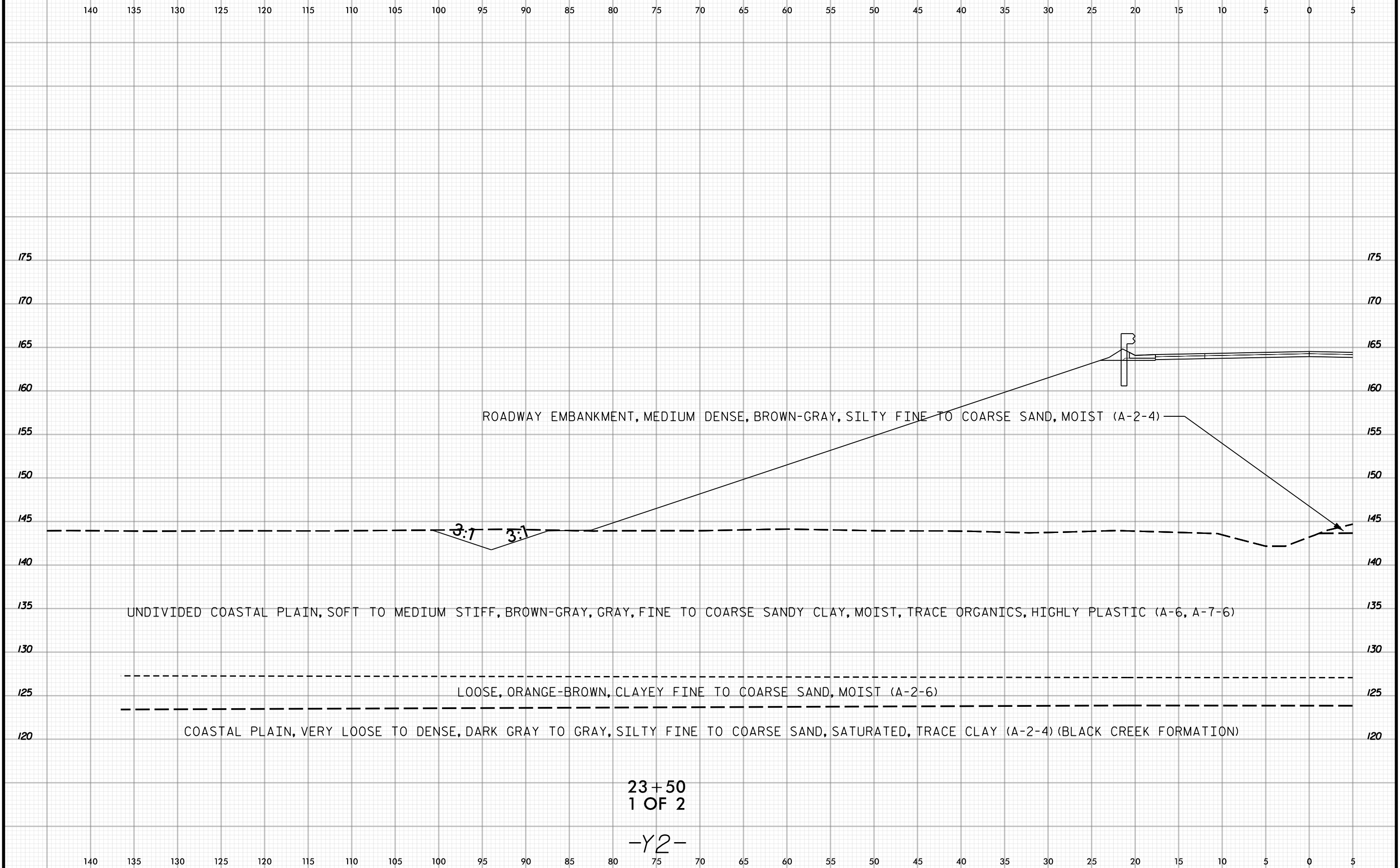

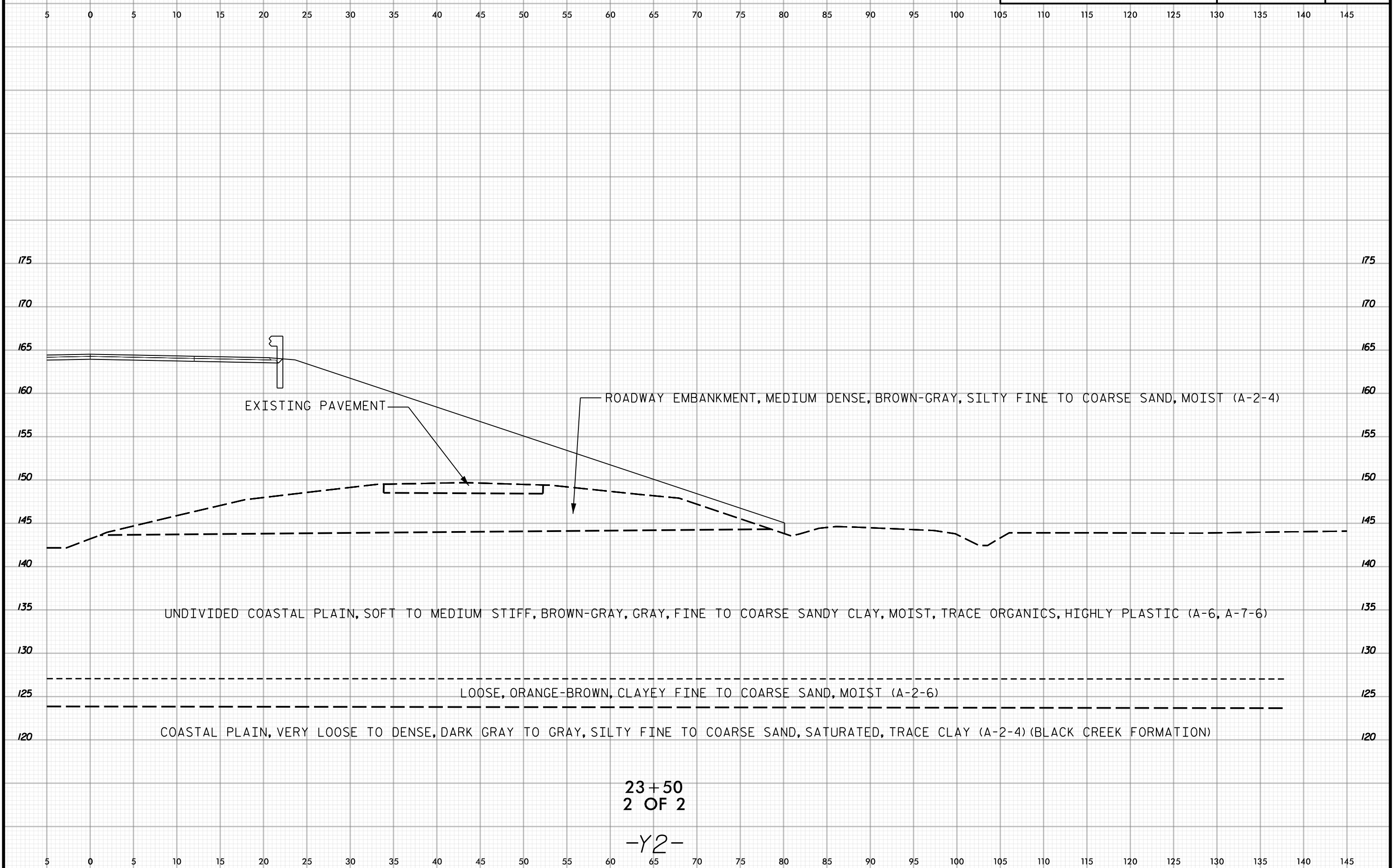

23+50  
2 OF 2

-Y2-

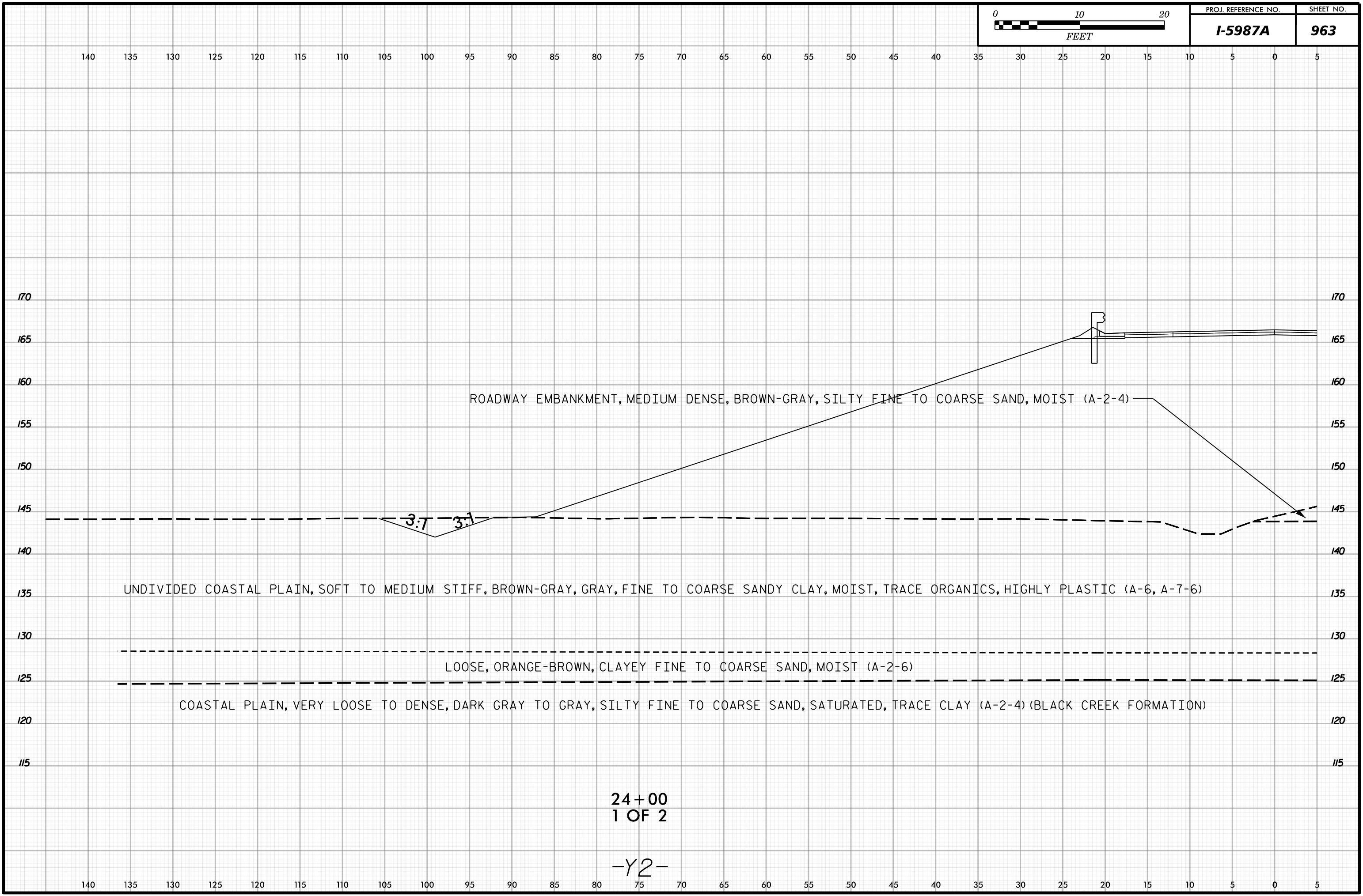

ROADWAY EMBANKMENT, MEDIUM DENSE, BROWN-GRAY, SILTY FINE TO COARSE SAND, MOIST (A-2-4)

UNDIVIDED COASTAL PLAIN, SOFT TO MEDIUM STIFF, BROWN-GRAY, GRAY, FINE TO COARSE SANDY CLAY, MOIST, TRACE ORGANICS, HIGHLY PLASTIC (A-6, A-7-6)

LOOSE, ORANGE-BROWN, CLAYEY FINE TO COARSE SAND, MOIST (A-2-6)

COASTAL PLAIN, VERY LOOSE TO DENSE, DARK GRAY TO GRAY, SILTY FINE TO COARSE SAND, SATURATED, TRACE CLAY (A-2-4) (BLACK CREEK FORMATION)

24+00  
1 OF 2

-Y2-

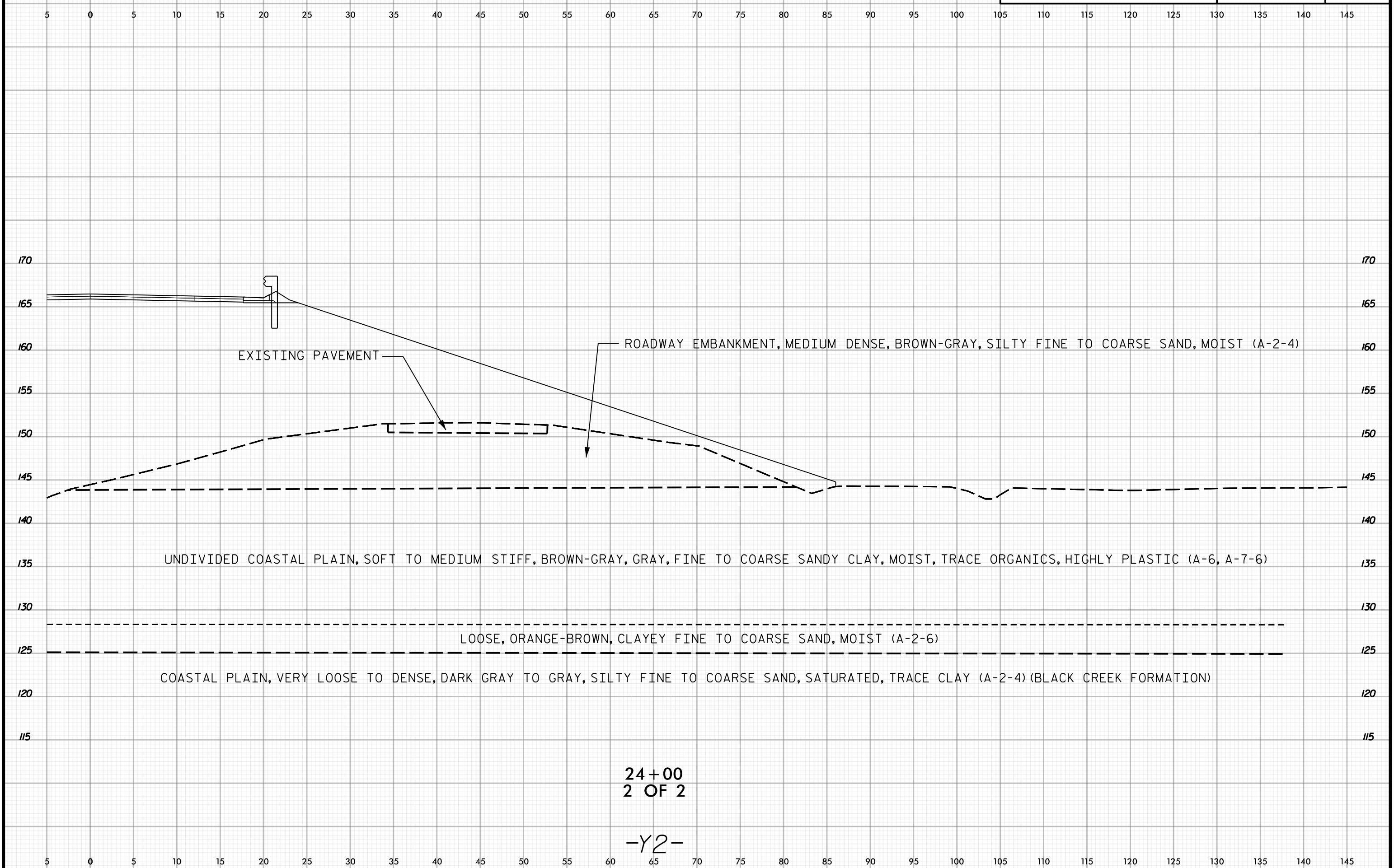

24+00  
2 OF 2

-Y2-

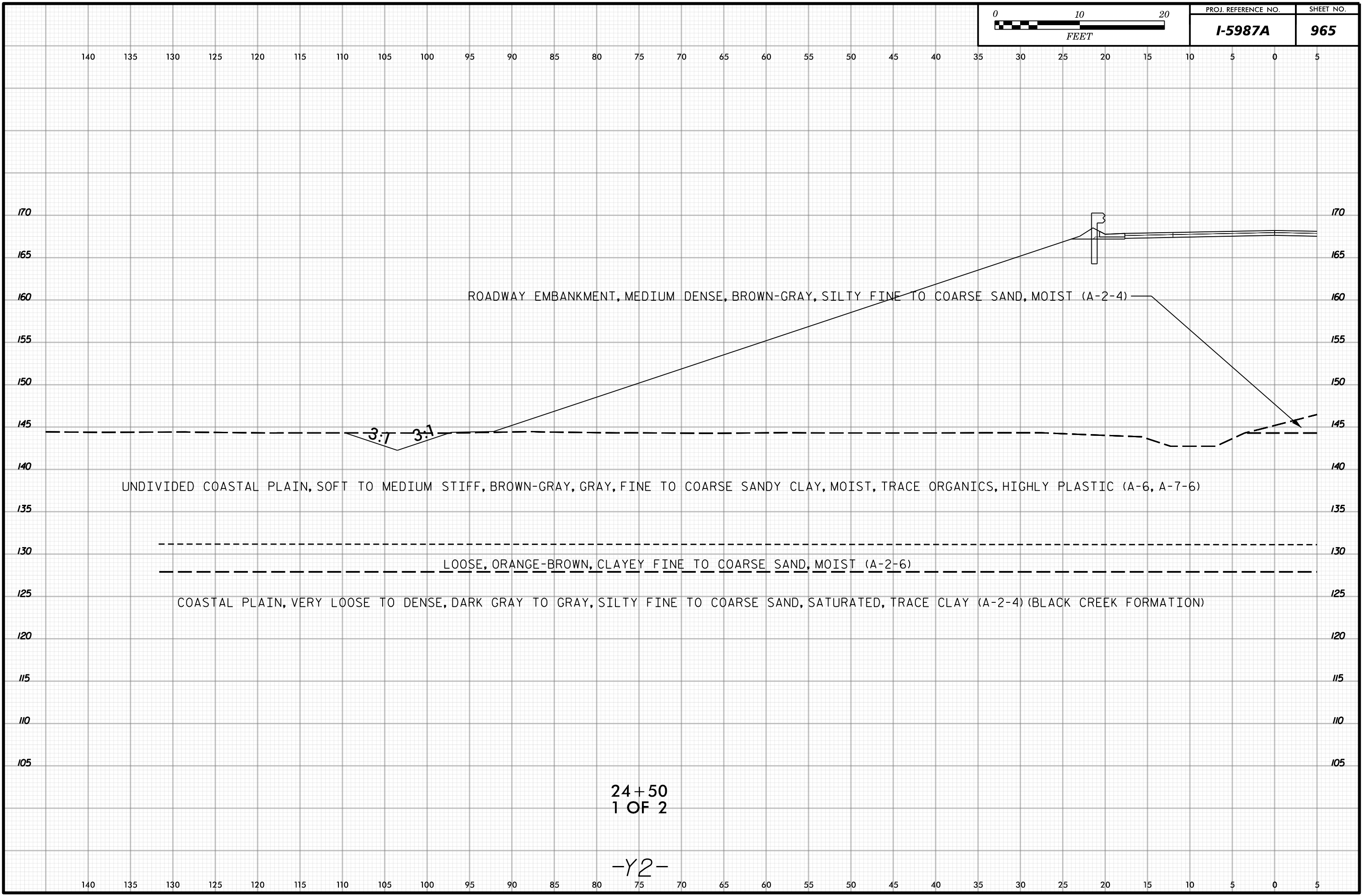

ROADWAY EMBANKMENT, MEDIUM DENSE, BROWN-GRAY, SILTY FINE TO COARSE SAND, MOIST (A-2-4)

UNDIVIDED COASTAL PLAIN, SOFT TO MEDIUM STIFF, BROWN-GRAY, GRAY, FINE TO COARSE SANDY CLAY, MOIST, TRACE ORGANICS, HIGHLY PLASTIC (A-6, A-7-6)

LOOSE, ORANGE-BROWN, CLAYEY FINE TO COARSE SAND, MOIST (A-2-6)

COASTAL PLAIN, VERY LOOSE TO DENSE, DARK GRAY TO GRAY, SILTY FINE TO COARSE SAND, SATURATED, TRACE CLAY (A-2-4) (BLACK CREEK FORMATION)

24+50  
1 OF 2

-Y2-



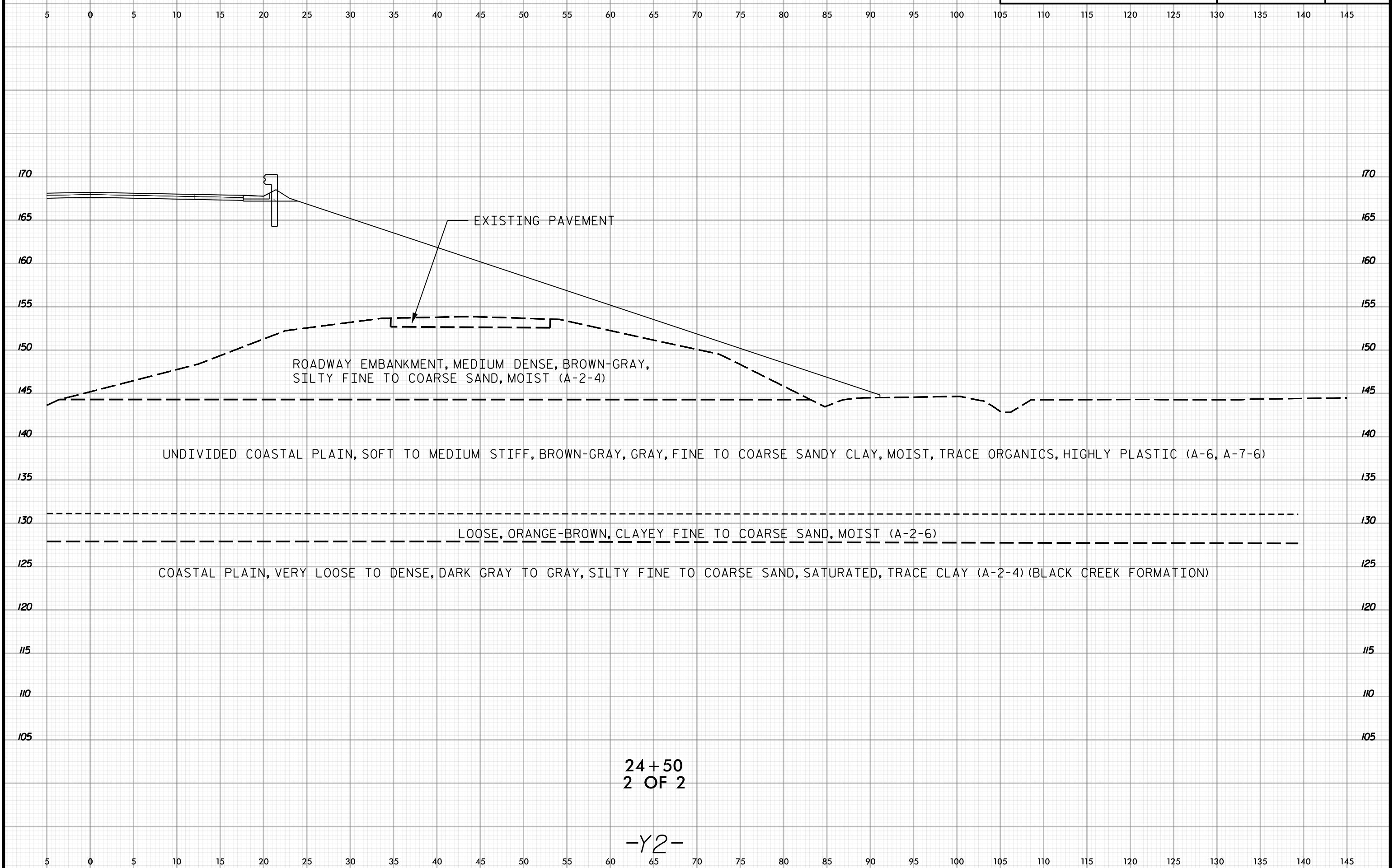

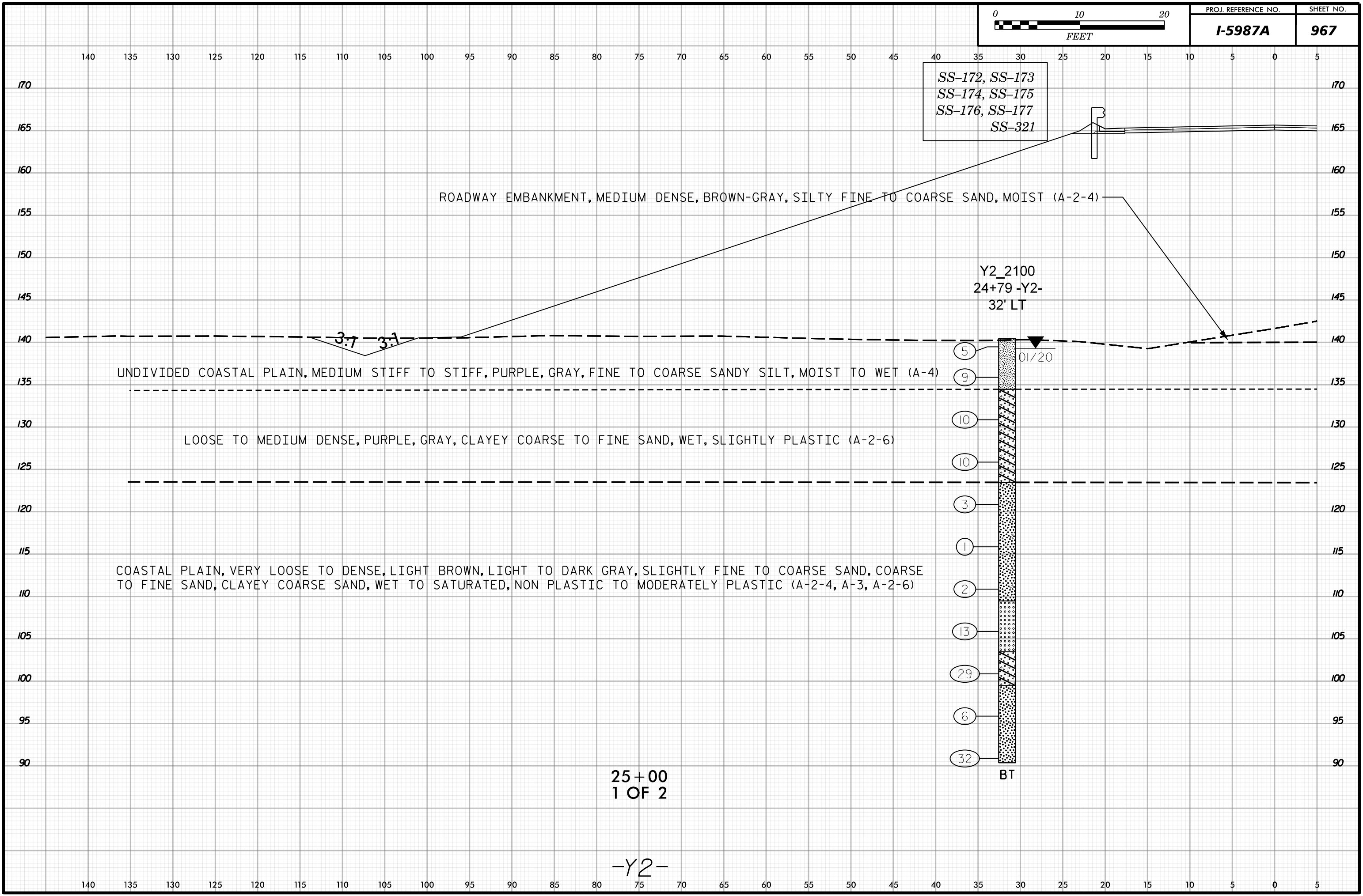
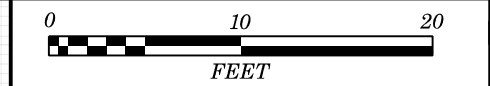

SS-172, SS-173  
 SS-174, SS-175  
 SS-176, SS-177  
 SS-321

ROADWAY EMBANKMENT, MEDIUM DENSE, BROWN-GRAY, SILTY FINE TO COARSE SAND, MOIST (A-2-4)

Y2\_2100  
 24+79 -Y2-  
 32' LT

UNDIVIDED COASTAL PLAIN, MEDIUM STIFF TO STIFF, PURPLE, GRAY, FINE TO COARSE SANDY SILT, MOIST TO WET (A-4)

LOOSE TO MEDIUM DENSE, PURPLE, GRAY, CLAYEY COARSE TO FINE SAND, WET, SLIGHTLY PLASTIC (A-2-6)

COASTAL PLAIN, VERY LOOSE TO DENSE, LIGHT BROWN, LIGHT TO DARK GRAY, SLIGHTLY FINE TO COARSE SAND, COARSE TO FINE SAND, CLAYEY COARSE SAND, WET TO SATURATED, NON PLASTIC TO MODERATELY PLASTIC (A-2-4, A-3, A-2-6)

25+00  
 1 OF 2

-Y2-

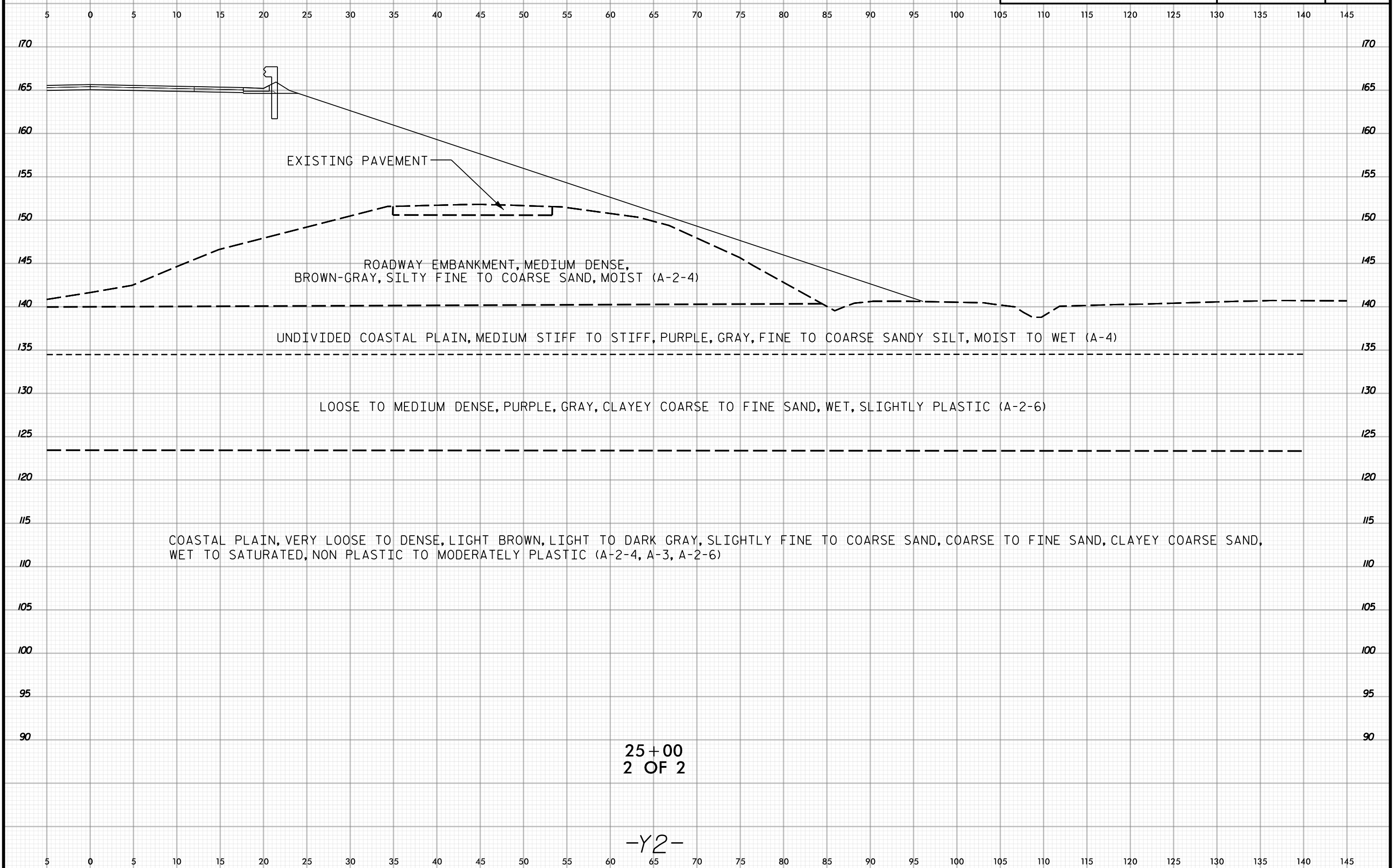

EXISTING PAVEMENT

ROADWAY EMBANKMENT, MEDIUM DENSE,  
BROWN-GRAY, SILTY FINE TO COARSE SAND, MOIST (A-2-4)

UNDIVIDED COASTAL PLAIN, MEDIUM STIFF TO STIFF, PURPLE, GRAY, FINE TO COARSE SANDY SILT, MOIST TO WET (A-4)

LOOSE TO MEDIUM DENSE, PURPLE, GRAY, CLAYEY COARSE TO FINE SAND, WET, SLIGHTLY PLASTIC (A-2-6)

COASTAL PLAIN, VERY LOOSE TO DENSE, LIGHT BROWN, LIGHT TO DARK GRAY, SLIGHTLY FINE TO COARSE SAND, COARSE TO FINE SAND, CLAYEY COARSE SAND,  
WET TO SATURATED, NON PLASTIC TO MODERATELY PLASTIC (A-2-4, A-3, A-2-6)

25+00  
2 OF 2

-Y2-

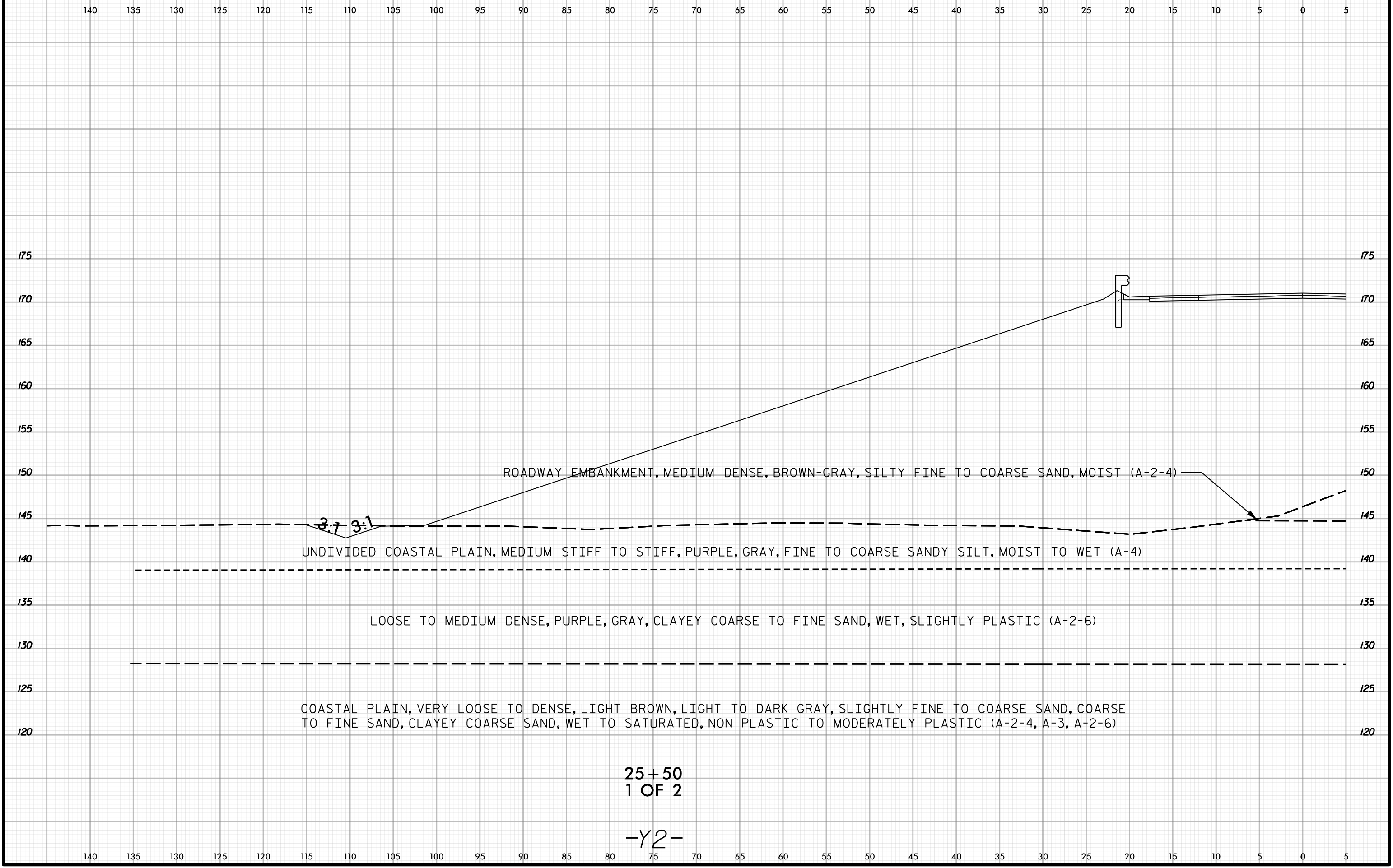



5 0 5 10 15 20 25 30 35 40 45 50 55 60 65 70 75 80 85 90 95 100 105 110 115 120 125 130 135 140 145

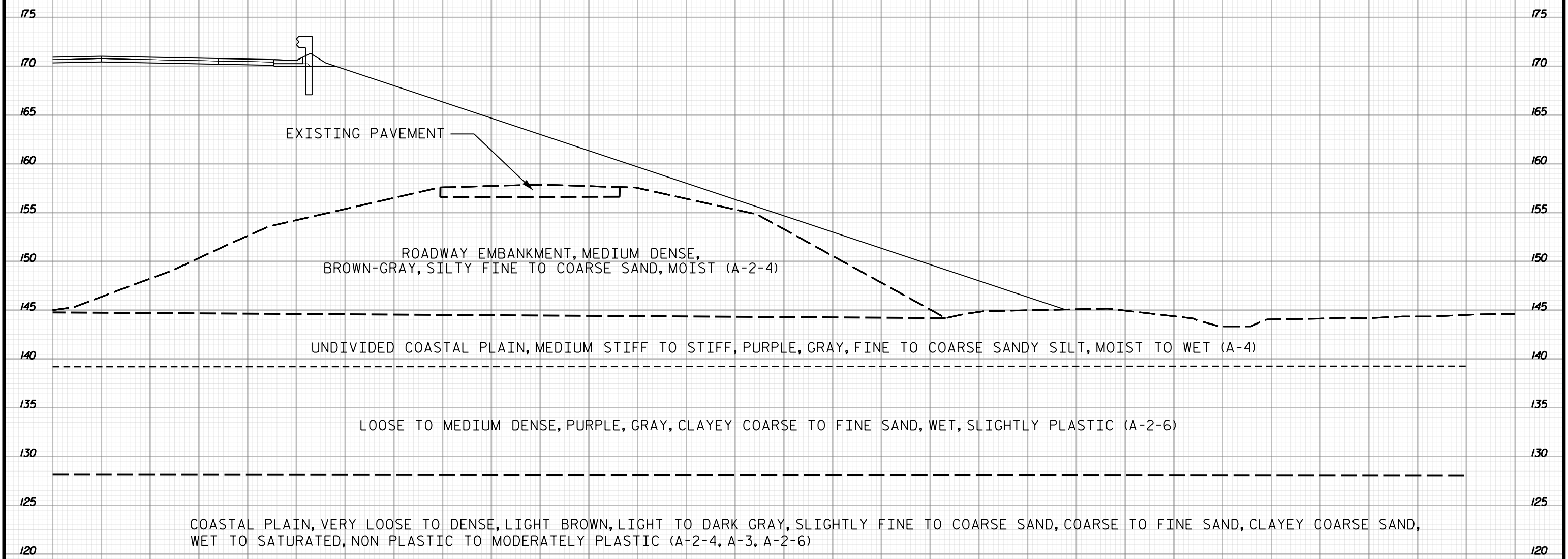

25+50  
2 OF 2

-Y2-

5 0 5 10 15 20 25 30 35 40 45 50 55 60 65 70 75 80 85 90 95 100 105 110 115 120 125 130 135 140 145

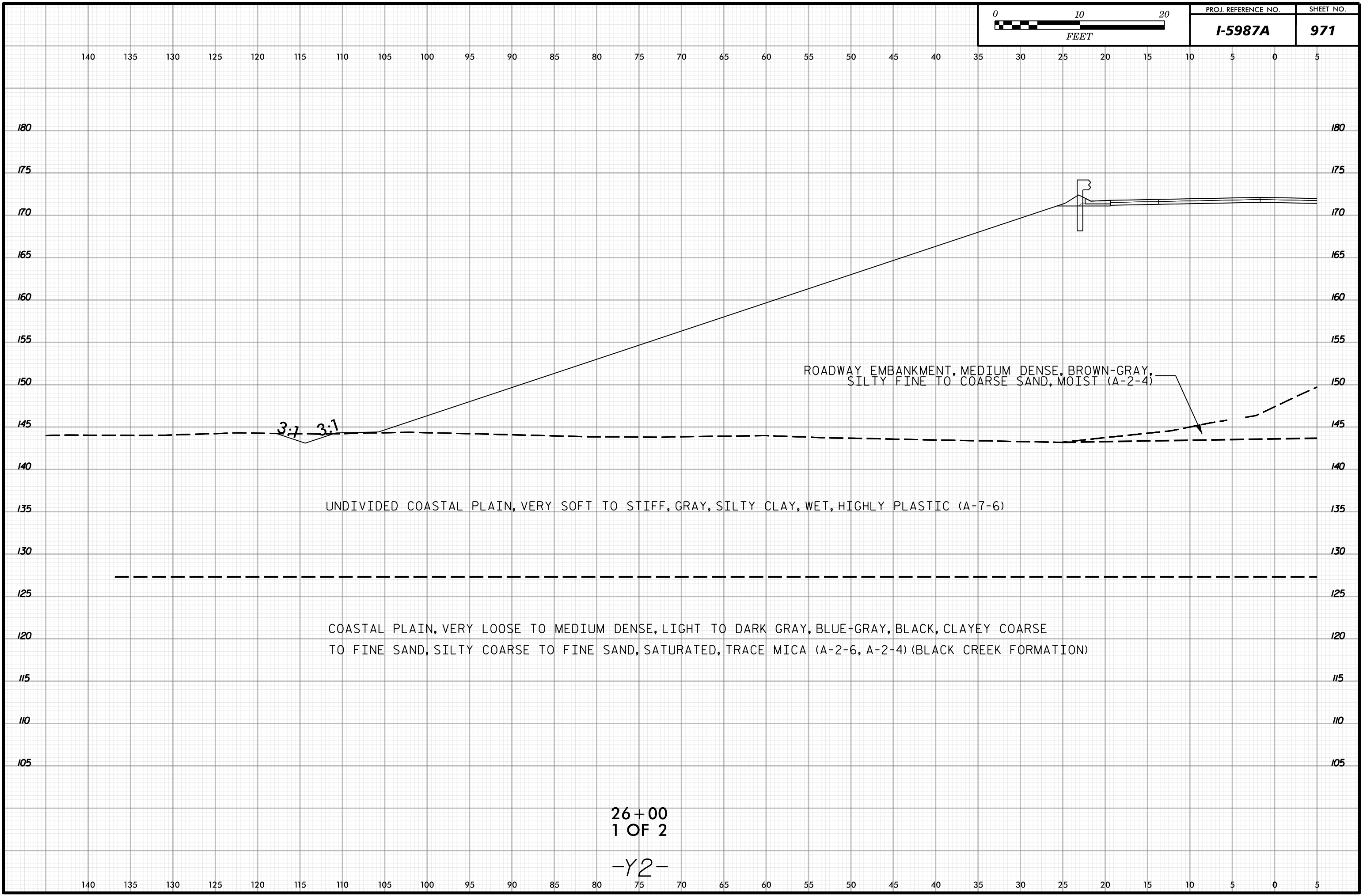

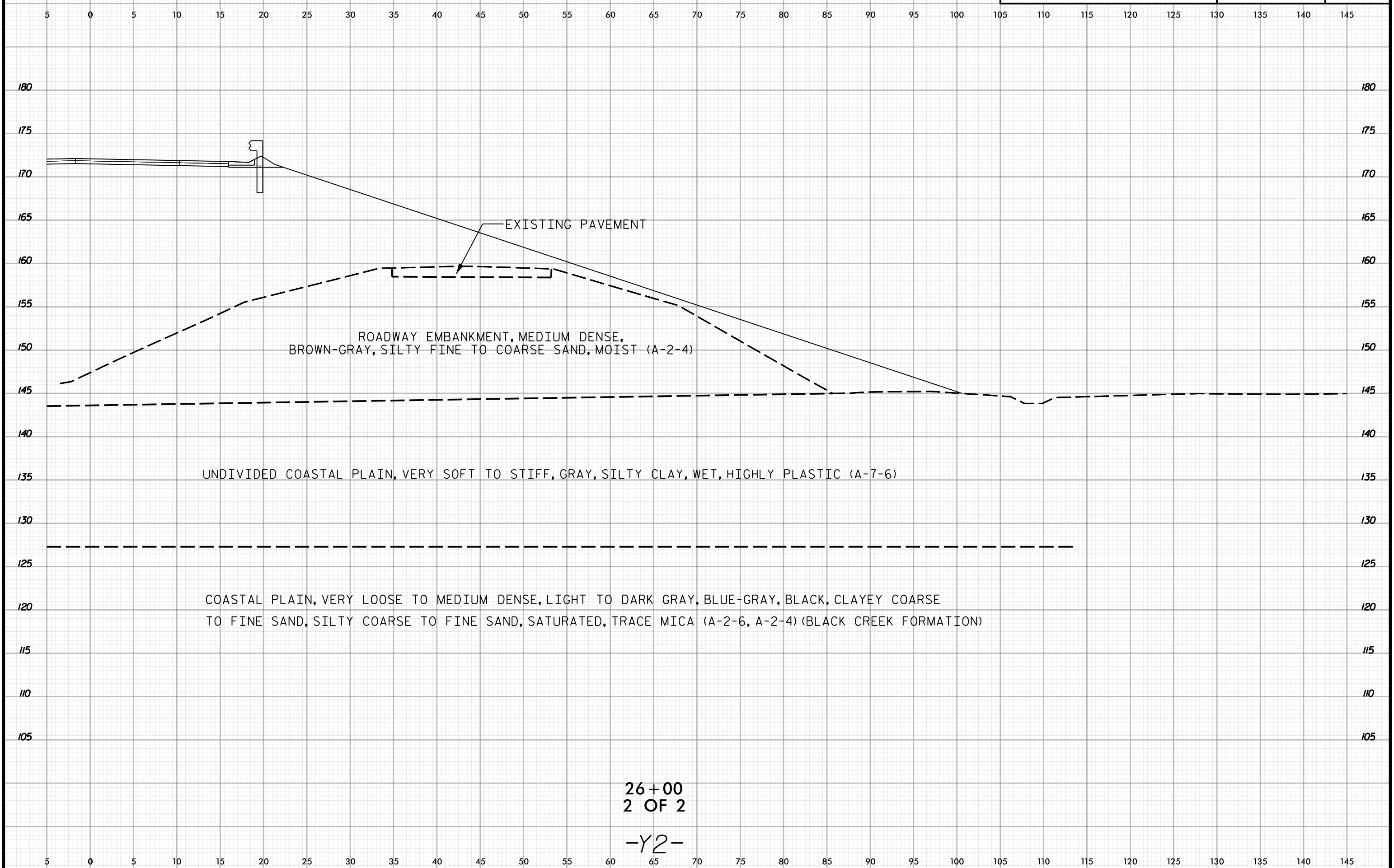

EXISTING PAVEMENT

ROADWAY EMBANKMENT, MEDIUM DENSE,  
BROWN-GRAY, SILTY FINE TO COARSE SAND, MOIST (A-2-4)

UNDIVIDED COASTAL PLAIN, VERY SOFT TO STIFF, GRAY, SILTY CLAY, WET, HIGHLY PLASTIC (A-7-6)

COASTAL PLAIN, VERY LOOSE TO MEDIUM DENSE, LIGHT TO DARK GRAY, BLUE-GRAY, BLACK, CLAYEY COARSE  
TO FINE SAND, SILTY COARSE TO FINE SAND, SATURATED, TRACE MICA (A-2-6, A-2-4) (BLACK CREEK FORMATION)

26+00  
2 OF 2

-Y2-

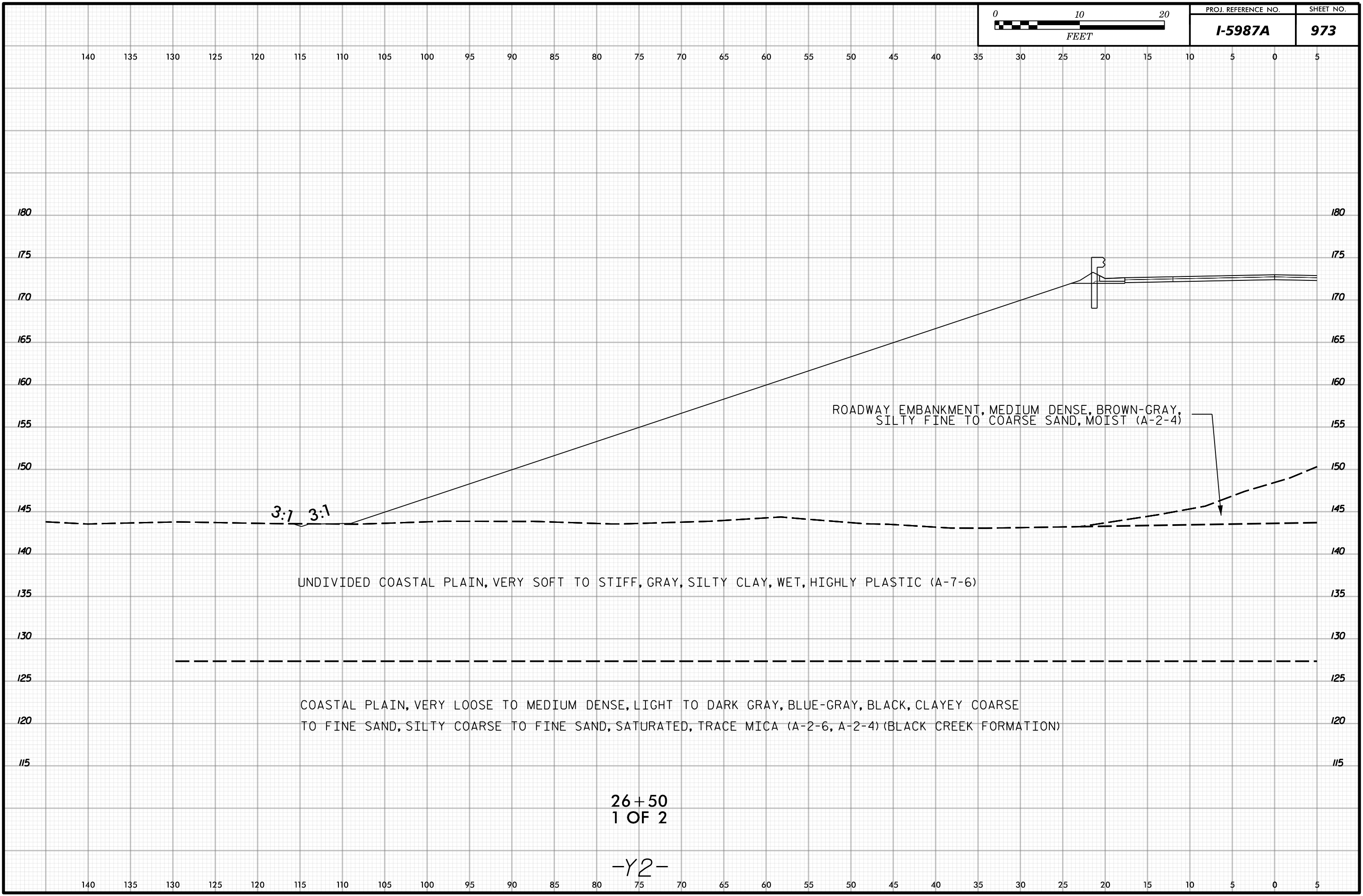
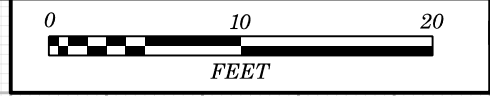

3:1 3:1

ROADWAY EMBANKMENT, MEDIUM DENSE, BROWN-GRAY, SILTY FINE TO COARSE SAND, MOIST (A-2-4)

UNDIVIDED COASTAL PLAIN, VERY SOFT TO STIFF, GRAY, SILTY CLAY, WET, HIGHLY PLASTIC (A-7-6)

COASTAL PLAIN, VERY LOOSE TO MEDIUM DENSE, LIGHT TO DARK GRAY, BLUE-GRAY, BLACK, CLAYEY COARSE TO FINE SAND, SILTY COARSE TO FINE SAND, SATURATED, TRACE MICA (A-2-6, A-2-4) (BLACK CREEK FORMATION)

26+50  
1 OF 2

-Y2-



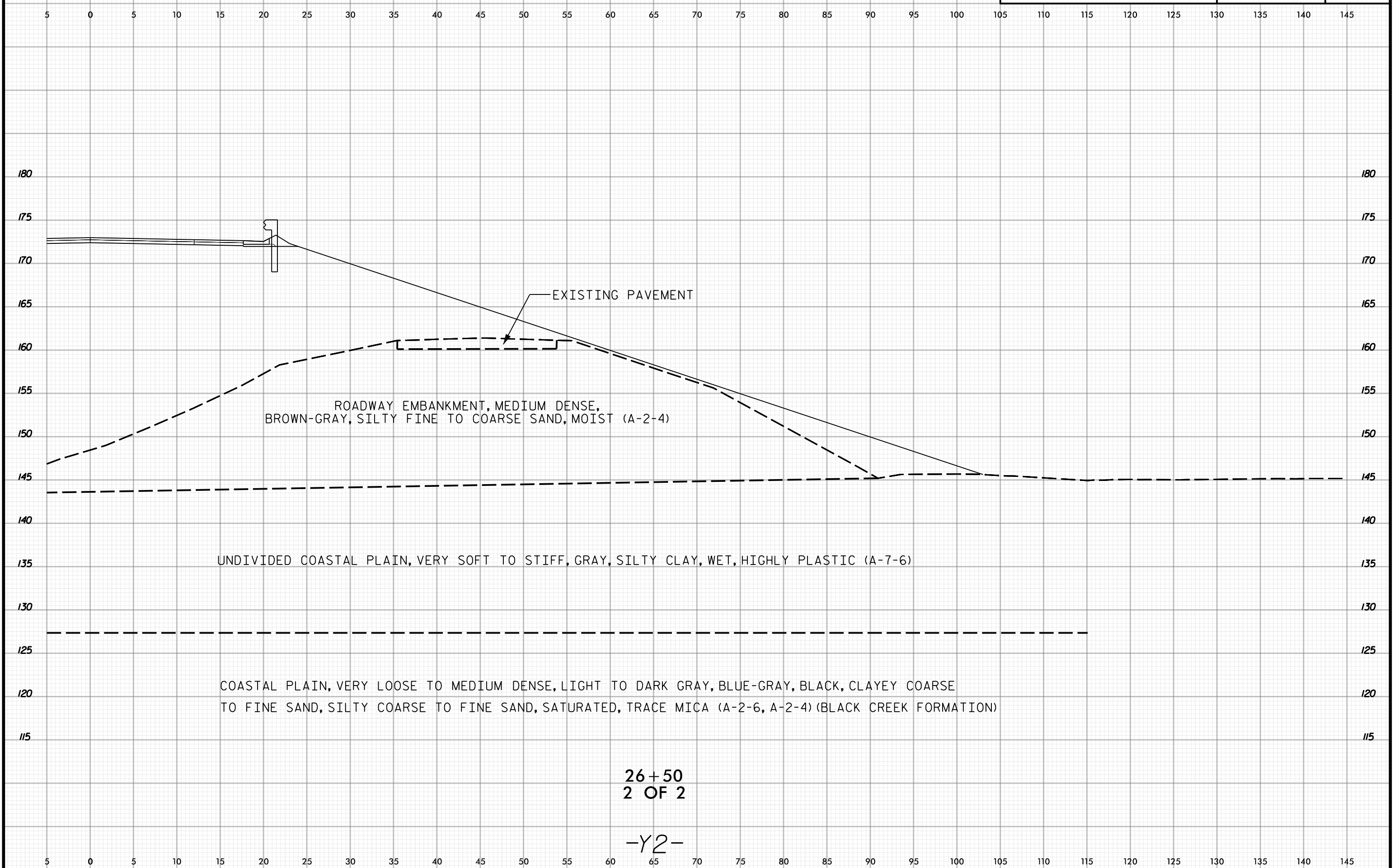

26+50  
2 OF 2

-Y2-

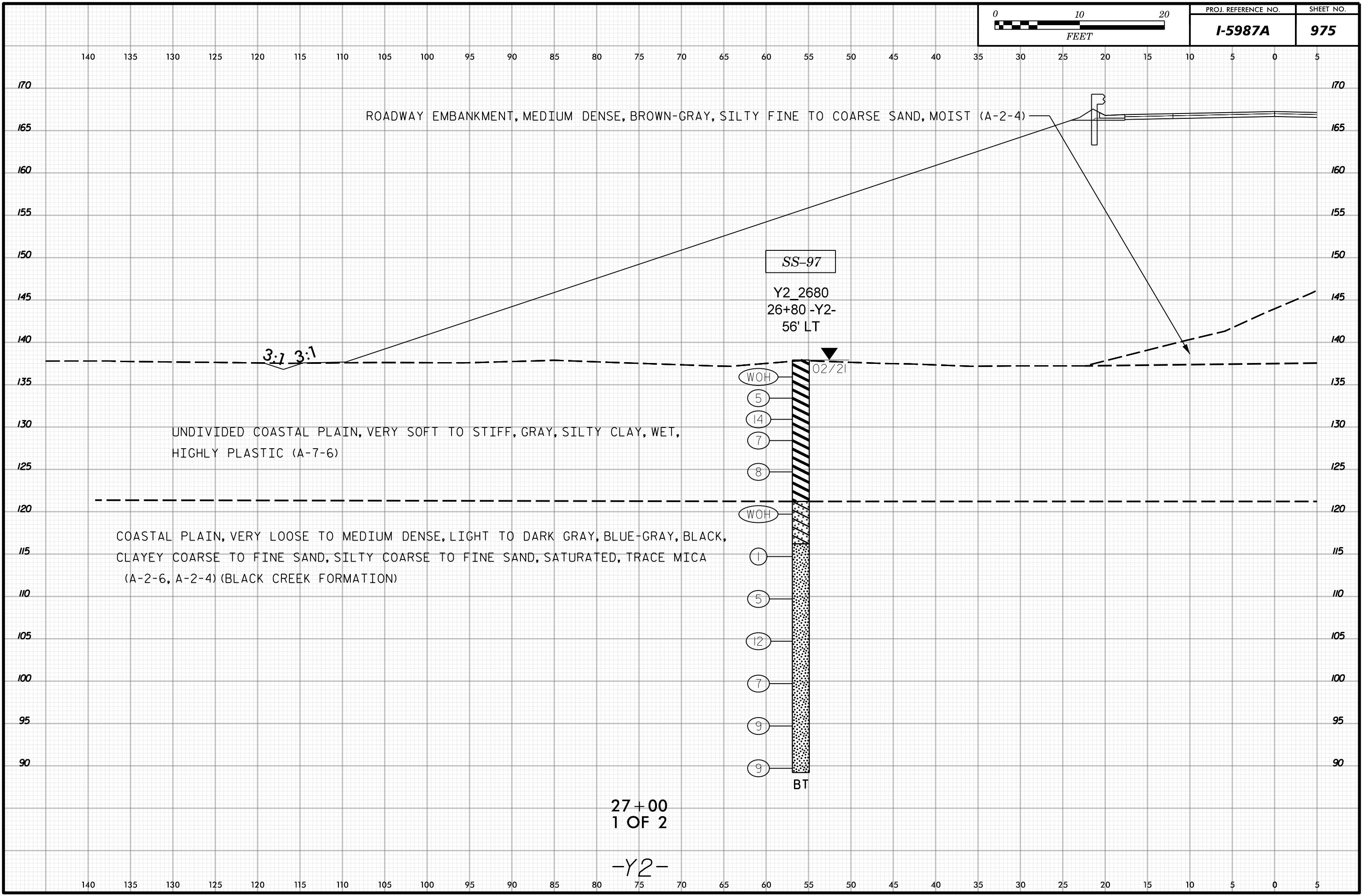
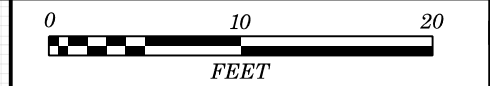

27+00  
1 OF 2

-Y2-

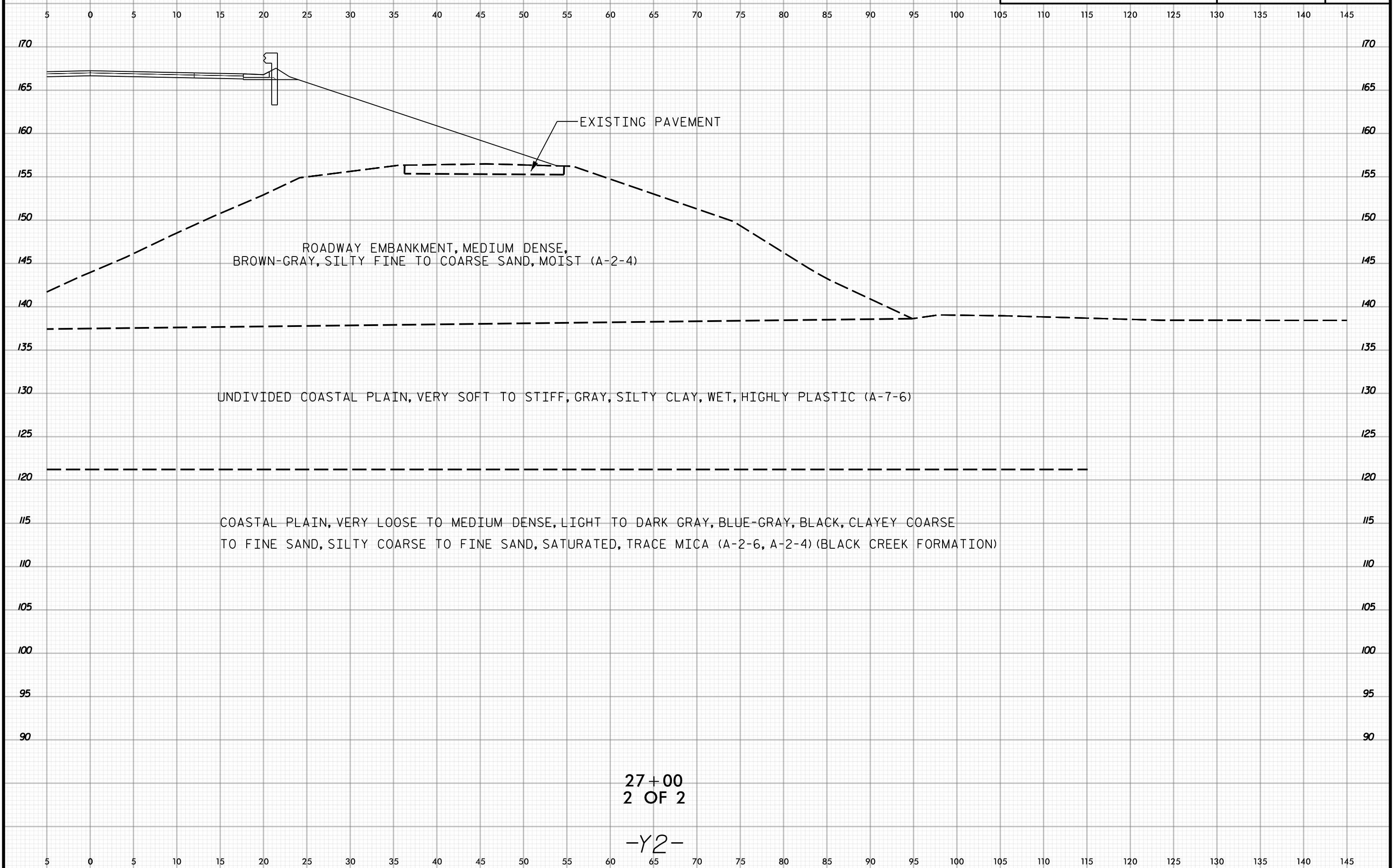

27+00  
2 OF 2

-Y2-

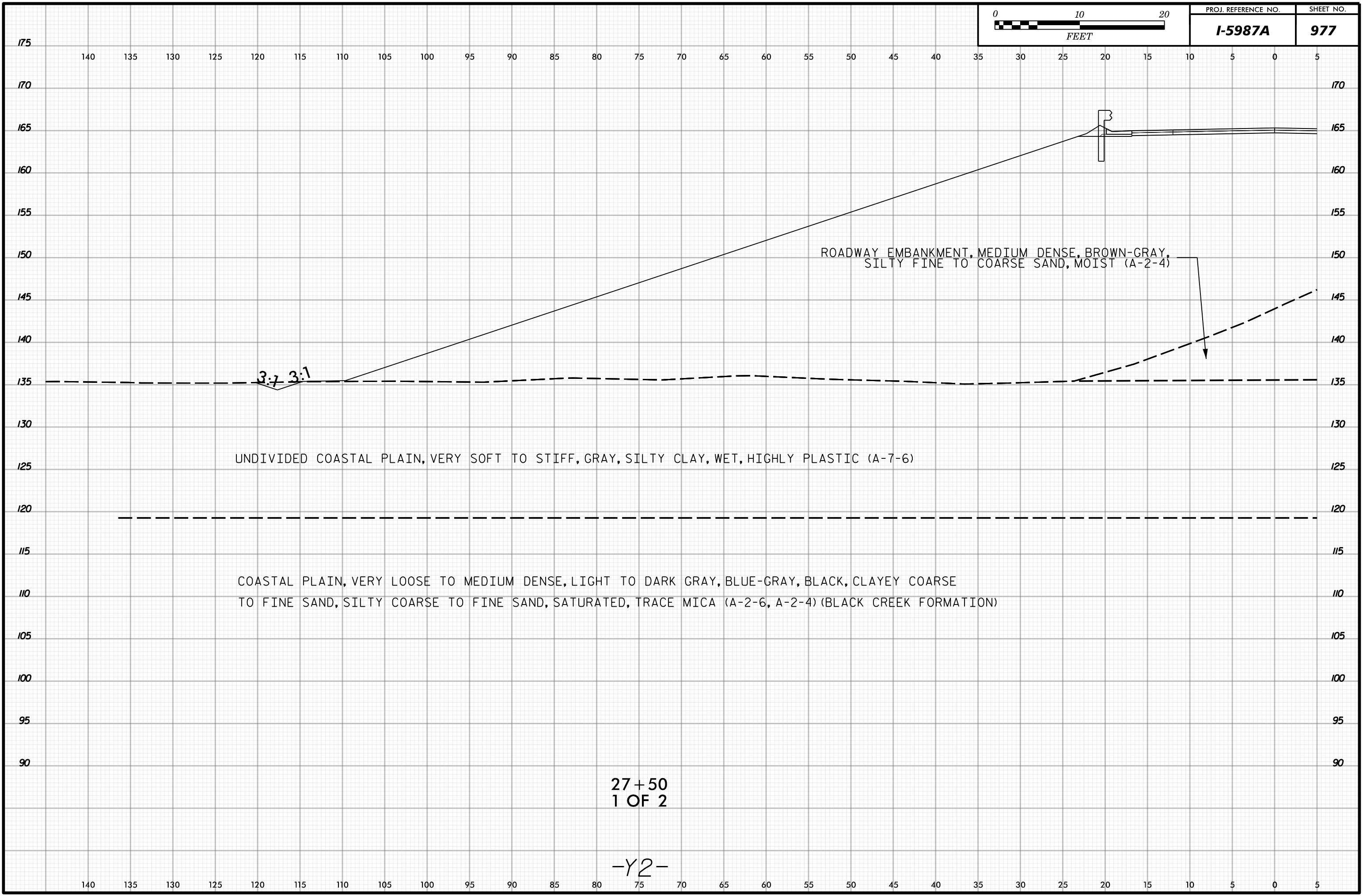

3:7 3:1

ROADWAY EMBANKMENT, MEDIUM DENSE, BROWN-GRAY,  
SILTY FINE TO COARSE SAND, MOIST (A-2-4)

UNDIVIDED COASTAL PLAIN, VERY SOFT TO STIFF, GRAY, SILTY CLAY, WET, HIGHLY PLASTIC (A-7-6)

COASTAL PLAIN, VERY LOOSE TO MEDIUM DENSE, LIGHT TO DARK GRAY, BLUE-GRAY, BLACK, CLAYEY COARSE  
TO FINE SAND, SILTY COARSE TO FINE SAND, SATURATED, TRACE MICA (A-2-6, A-2-4) (BLACK CREEK FORMATION)

27+50  
1 OF 2

-Y2-

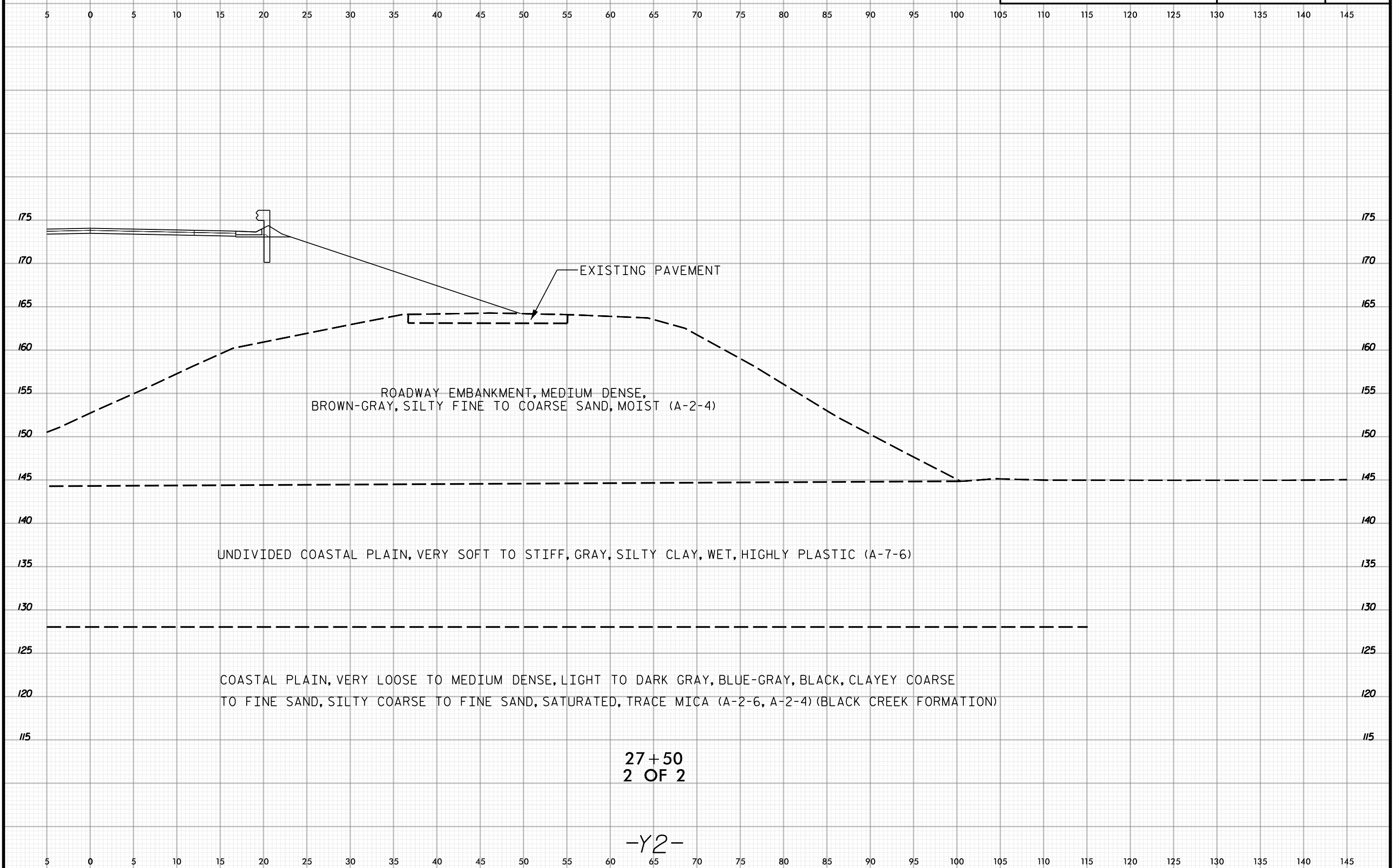

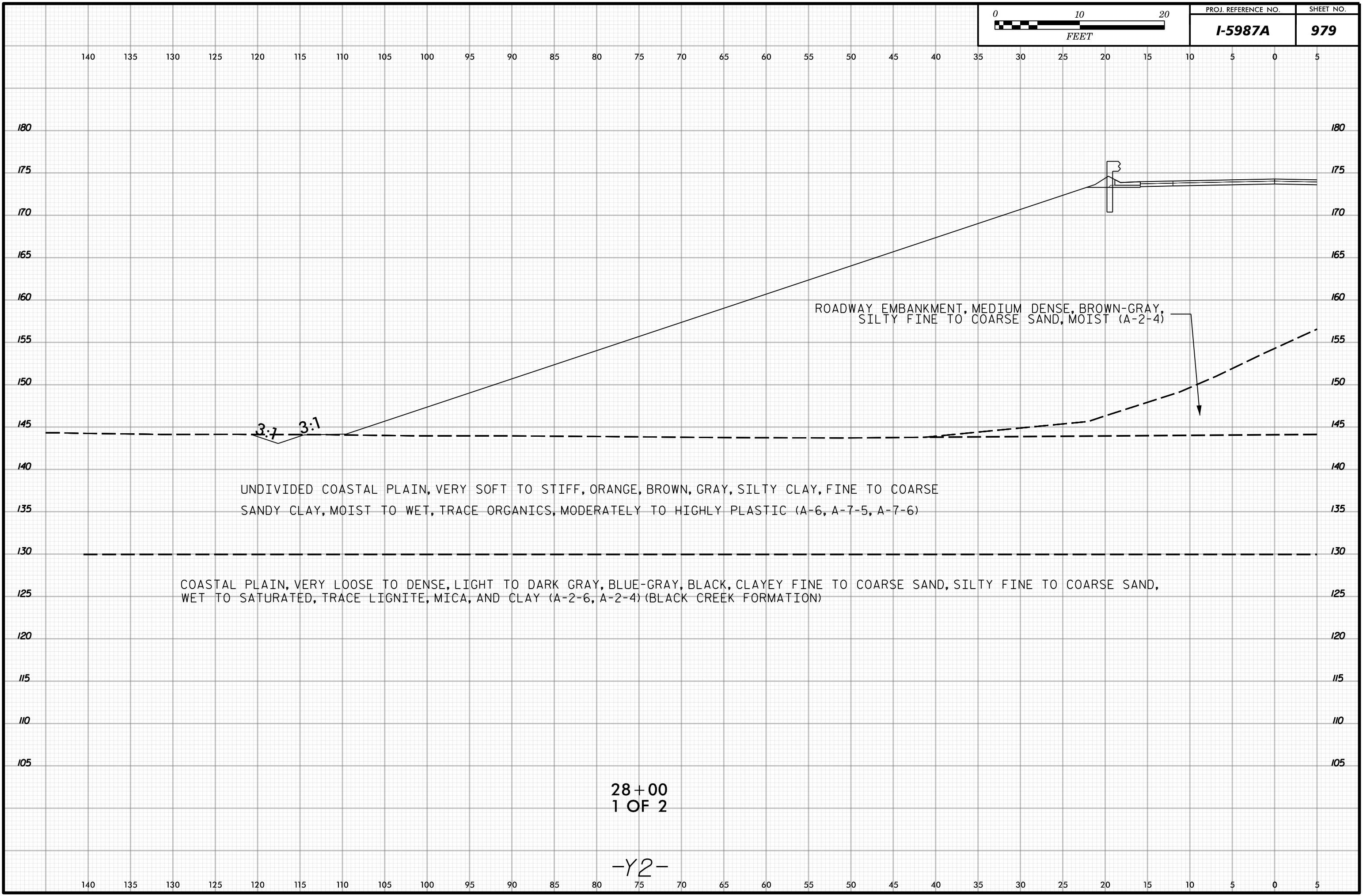
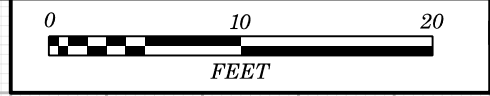

28+00  
1 OF 2

-Y2-

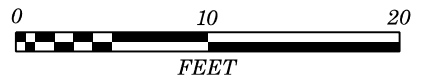

5 0 5 10 15 20 25 30 35 40 45 50 55 60 65 70 75 80 85 90 95 100 105 110 115 120 125 130 135 140 145

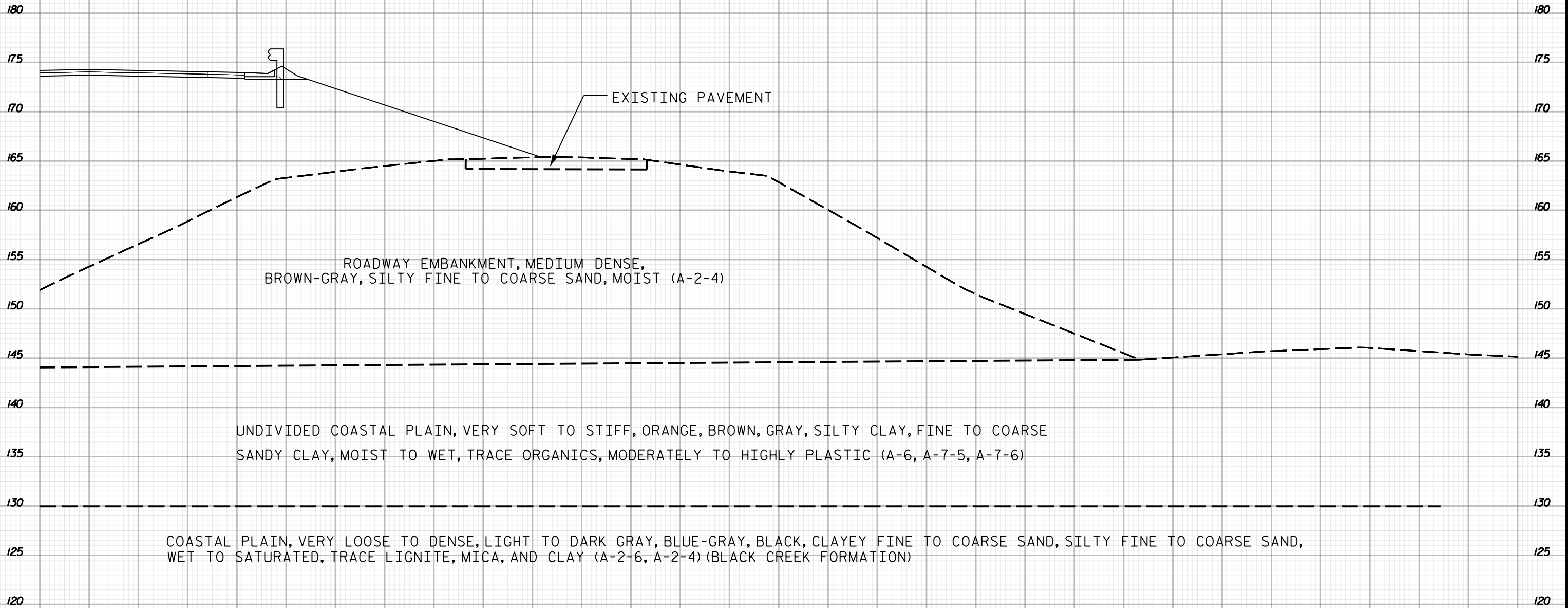

ROADWAY EMBANKMENT, MEDIUM DENSE,  
BROWN-GRAY, SILTY FINE TO COARSE SAND, MOIST (A-2-4)

UNDIVIDED COASTAL PLAIN, VERY SOFT TO STIFF, ORANGE, BROWN, GRAY, SILTY CLAY, FINE TO COARSE  
SANDY CLAY, MOIST TO WET, TRACE ORGANICS, MODERATELY TO HIGHLY PLASTIC (A-6, A-7-5, A-7-6)

COASTAL PLAIN, VERY LOOSE TO DENSE, LIGHT TO DARK GRAY, BLUE-GRAY, BLACK, CLAYEY FINE TO COARSE SAND, SILTY FINE TO COARSE SAND,  
WET TO SATURATED, TRACE LIGNITE, MICA, AND CLAY (A-2-6, A-2-4) (BLACK CREEK FORMATION)

28+00  
2 OF 2

-Y2-

5 0 5 10 15 20 25 30 35 40 45 50 55 60 65 70 75 80 85 90 95 100 105 110 115 120 125 130 135 140 145

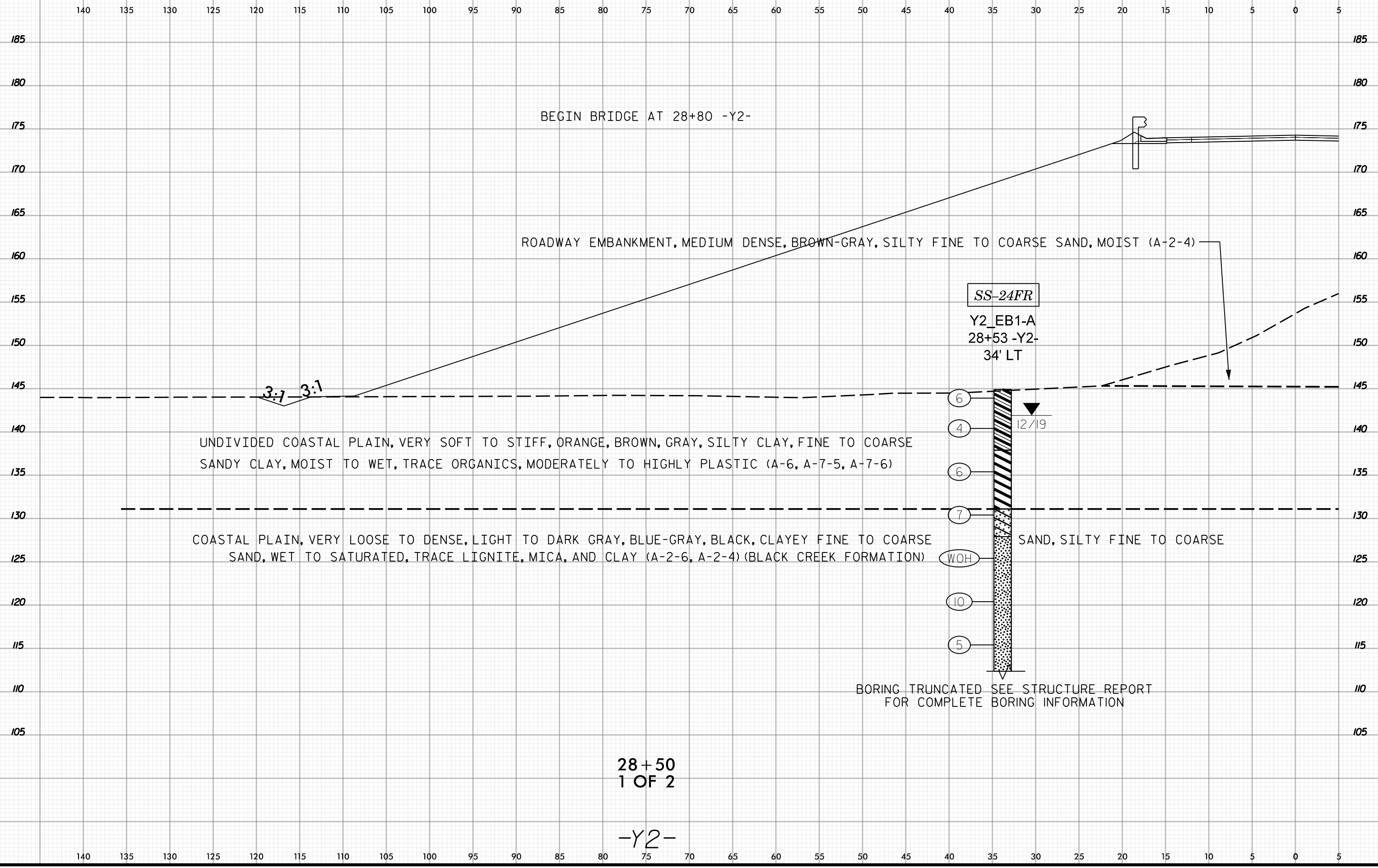
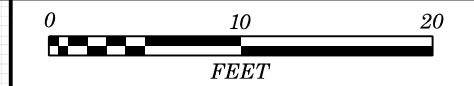

BEGIN BRIDGE AT 28+80 -Y2-

ROADWAY EMBANKMENT, MEDIUM DENSE, BROWN-GRAY, SILTY FINE TO COARSE SAND, MOIST (A-2-4)

3:1 3:1

UNDIVIDED COASTAL PLAIN, VERY SOFT TO STIFF, ORANGE, BROWN, GRAY, SILTY CLAY, FINE TO COARSE SANDY CLAY, MOIST TO WET, TRACE ORGANICS, MODERATELY TO HIGHLY PLASTIC (A-6, A-7-5, A-7-6)

COASTAL PLAIN, VERY LOOSE TO DENSE, LIGHT TO DARK GRAY, BLUE-GRAY, BLACK, CLAYEY FINE TO COARSE SAND, WET TO SATURATED, TRACE LIGNITE, MICA, AND CLAY (A-2-6, A-2-4) (BLACK CREEK FORMATION)

SS-24FR  
Y2\_EB1-A  
28+53 -Y2-  
34' LT

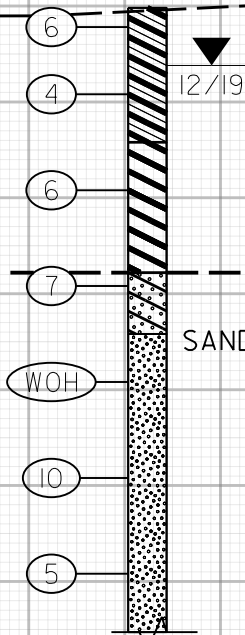

12/19

SAND, SILTY FINE TO COARSE

BORING TRUNCATED SEE STRUCTURE REPORT FOR COMPLETE BORING INFORMATION

28+50  
1 OF 2

-Y2-



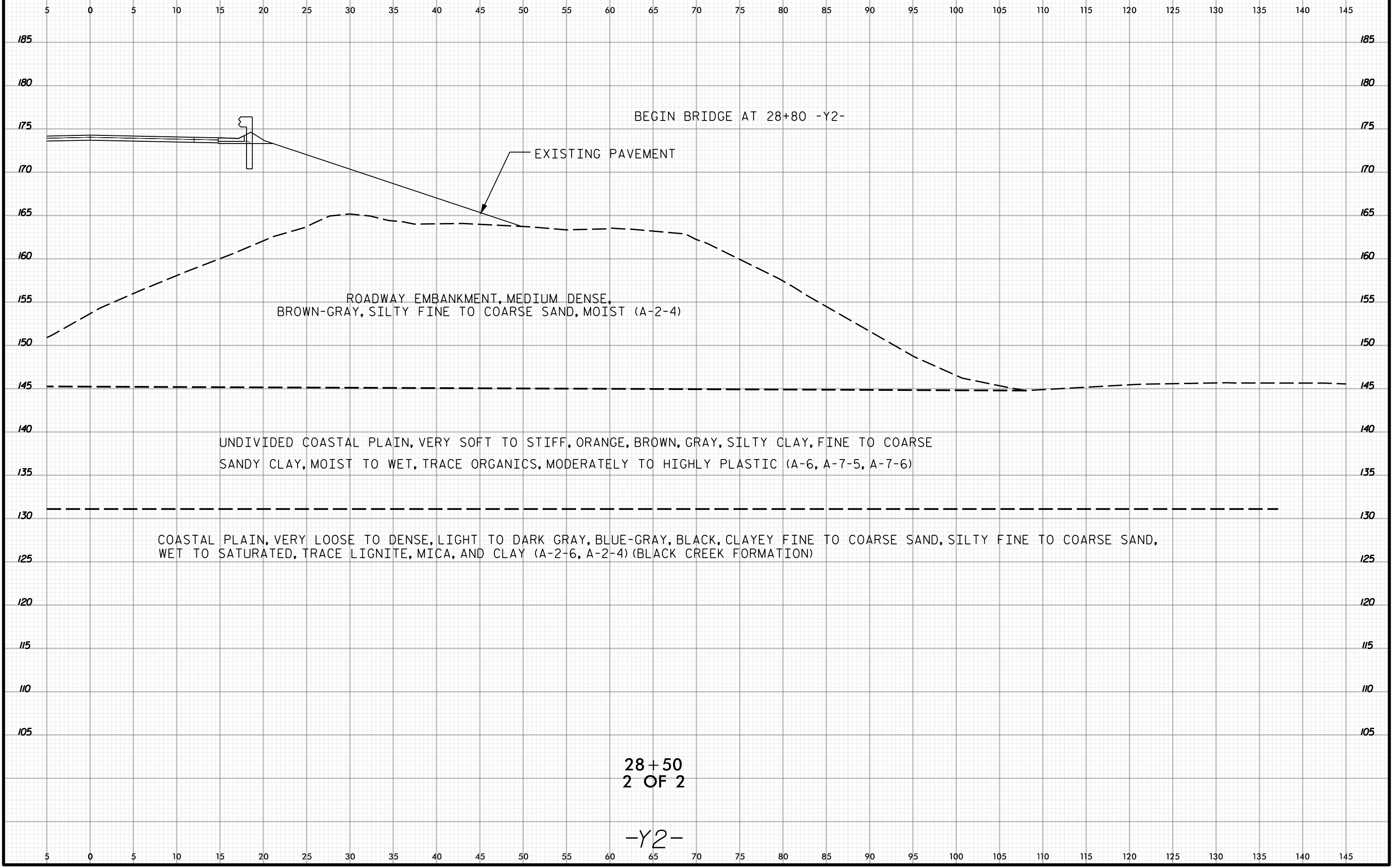

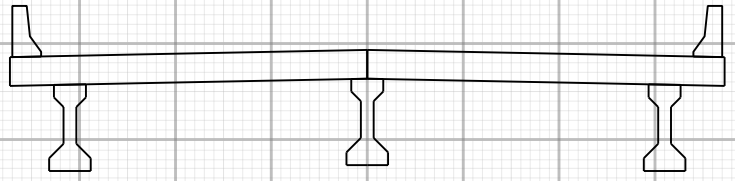
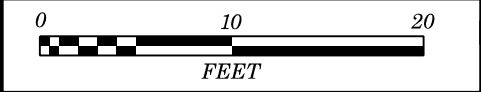

75 70 65 60 55 50 45 40 35 30 25 20 15 10 5 0 5 10 15 20 25 30 35 40 45 50 55 60 65 70 75

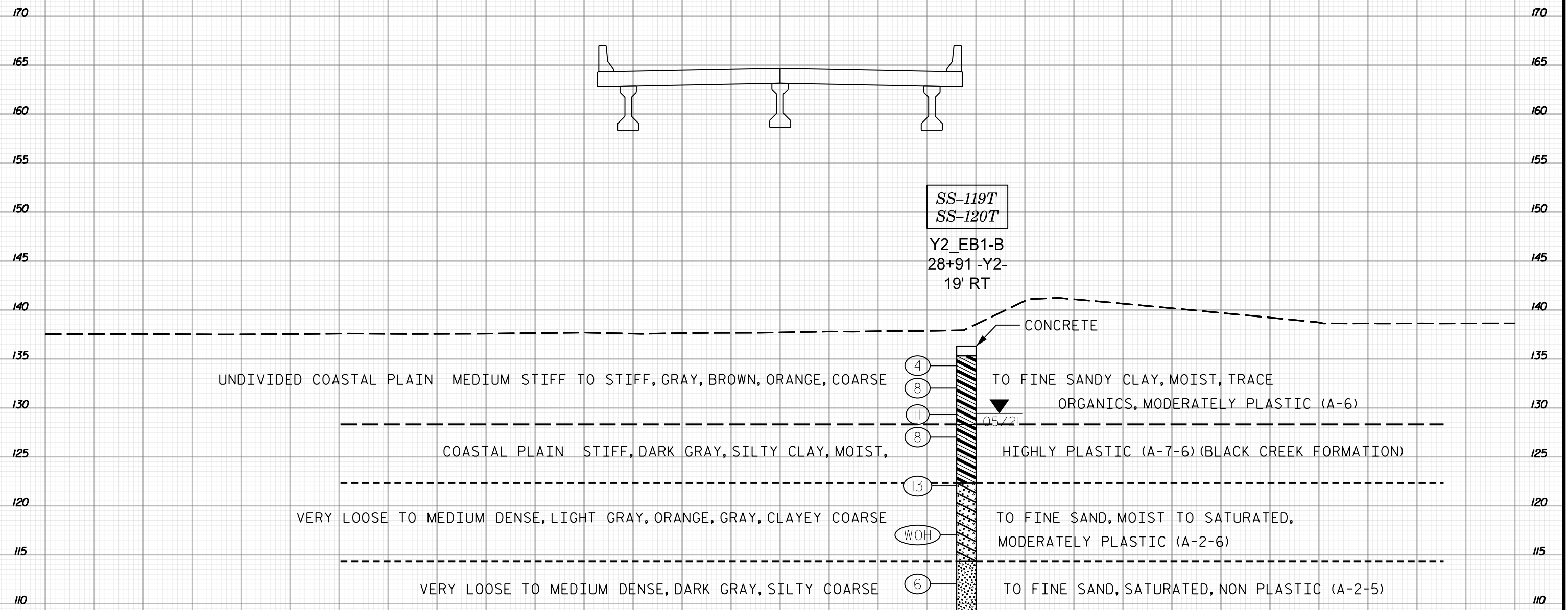

BORING TRUNCATED SEE STRUCTURE REPORT FOR COMPLETE BORING INFORMATION

29+00

-Y2-

75 70 65 60 55 50 45 40 35 30 25 20 15 10 5 0 5 10 15 20 25 30 35 40 45 50 55 60 65 70 75

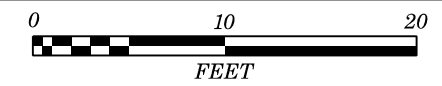

145 140 135 130 125 120 115 110 105 100 95 90 85 80 75 70 65 60 55 50 45 40 35 30 25 20 15 10 5 0 5

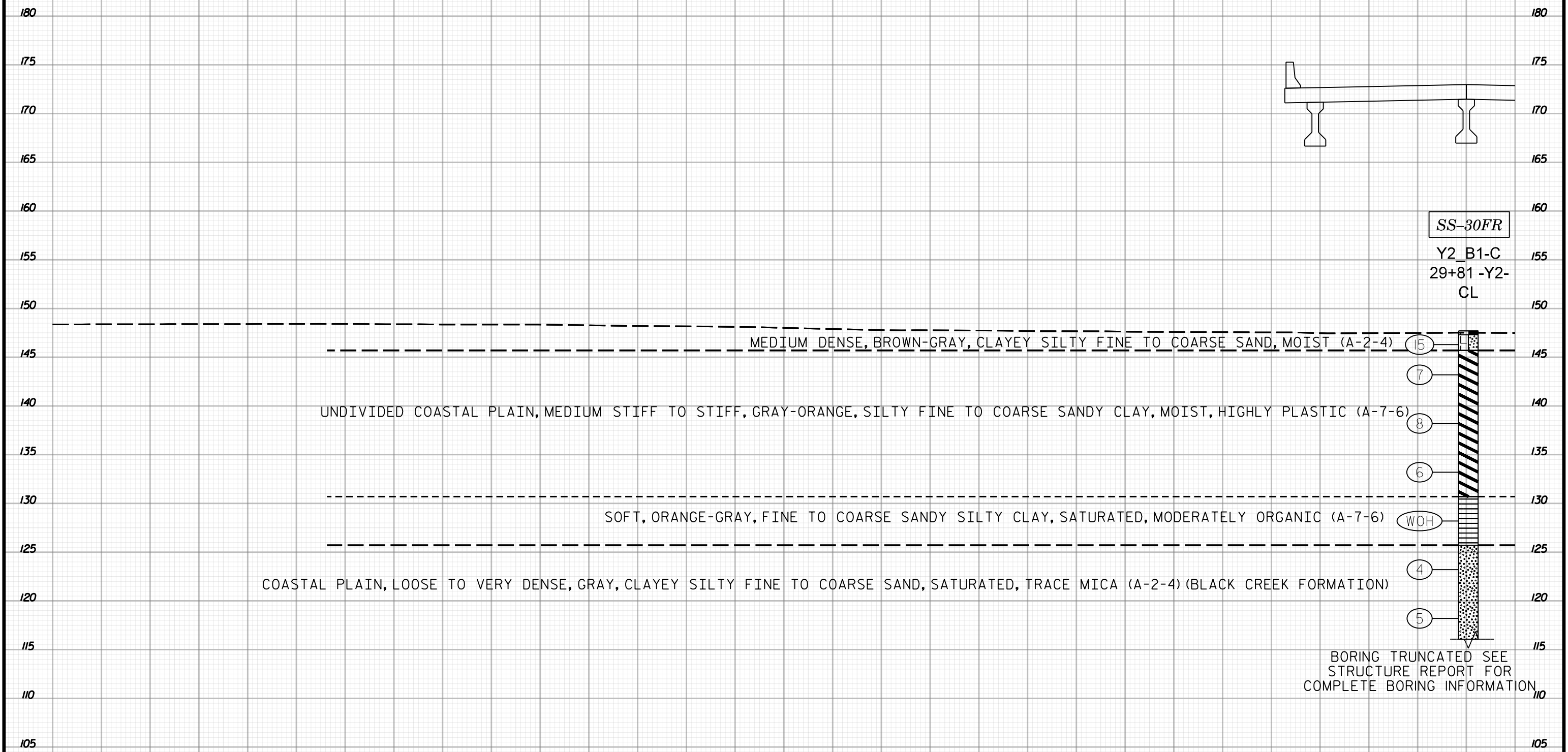

30+00  
1 OF 2

-Y2-

145 140 135 130 125 120 115 110 105 100 95 90 85 80 75 70 65 60 55 50 45 40 35 30 25 20 15 10 5 0 5

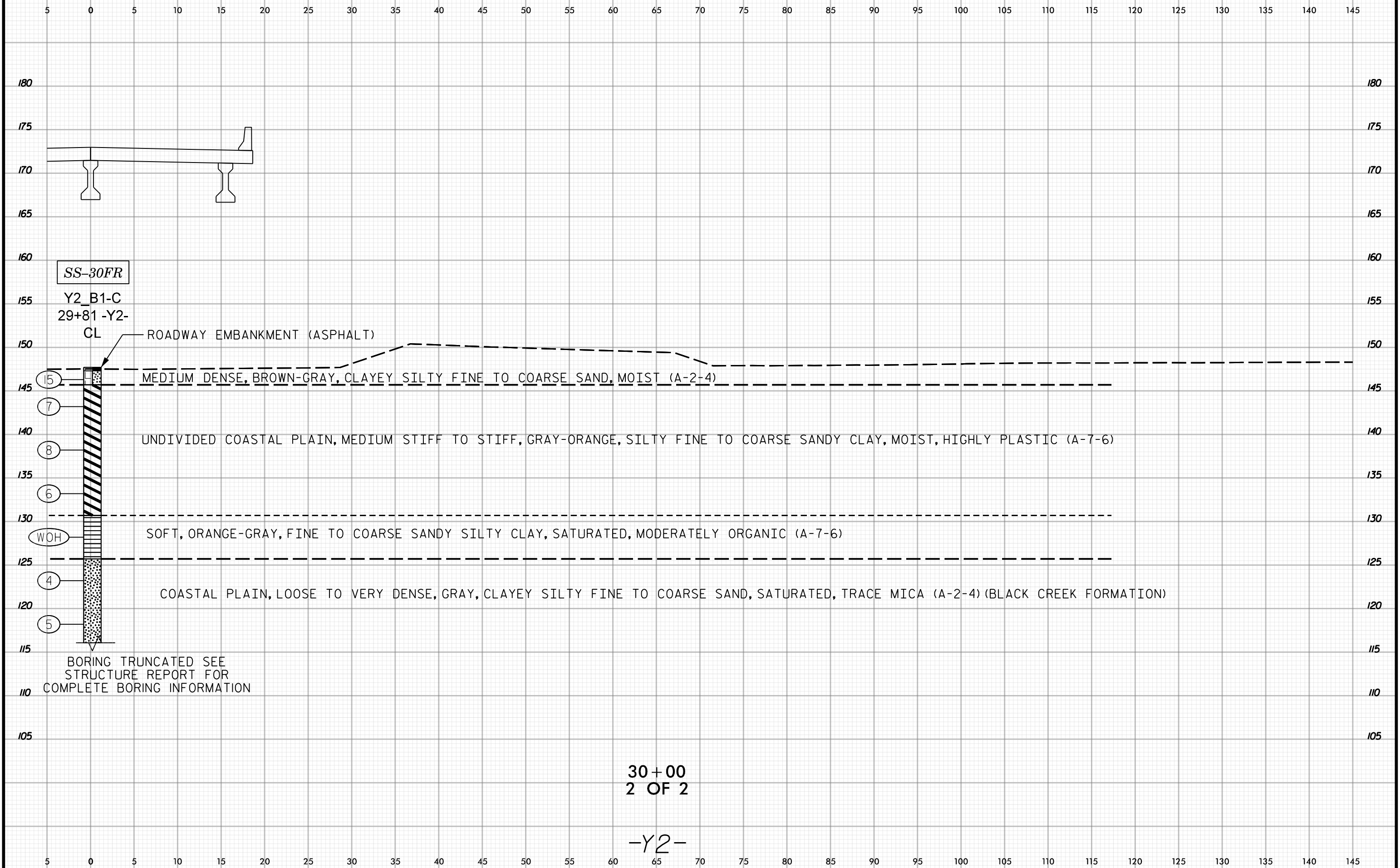
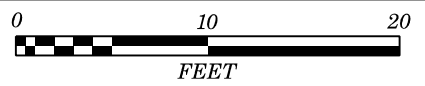

SS-30FR

Y2\_B1-C  
29+81 -Y2-

CL ROADWAY EMBANKMENT (ASPHALT)

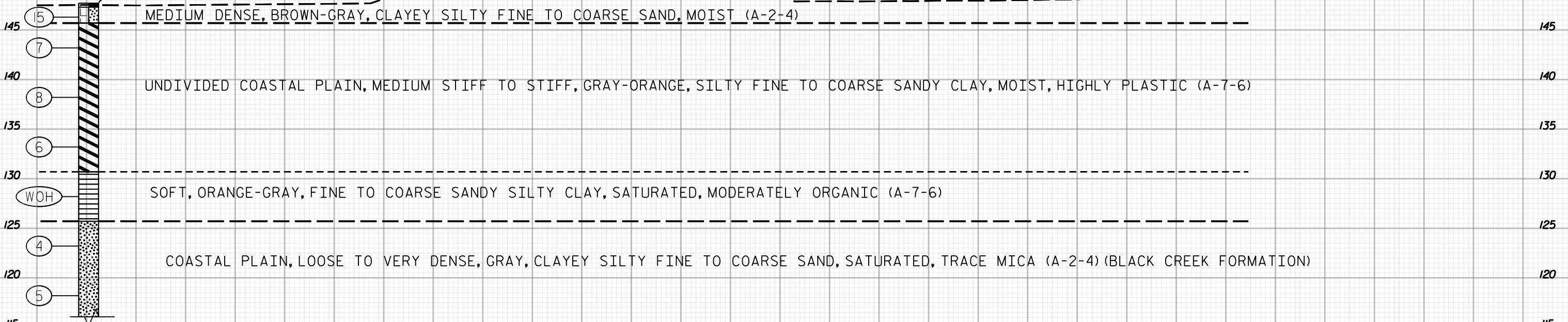

BORING TRUNCATED SEE  
STRUCTURE REPORT FOR  
COMPLETE BORING INFORMATION

30+00  
2 OF 2

-Y2-

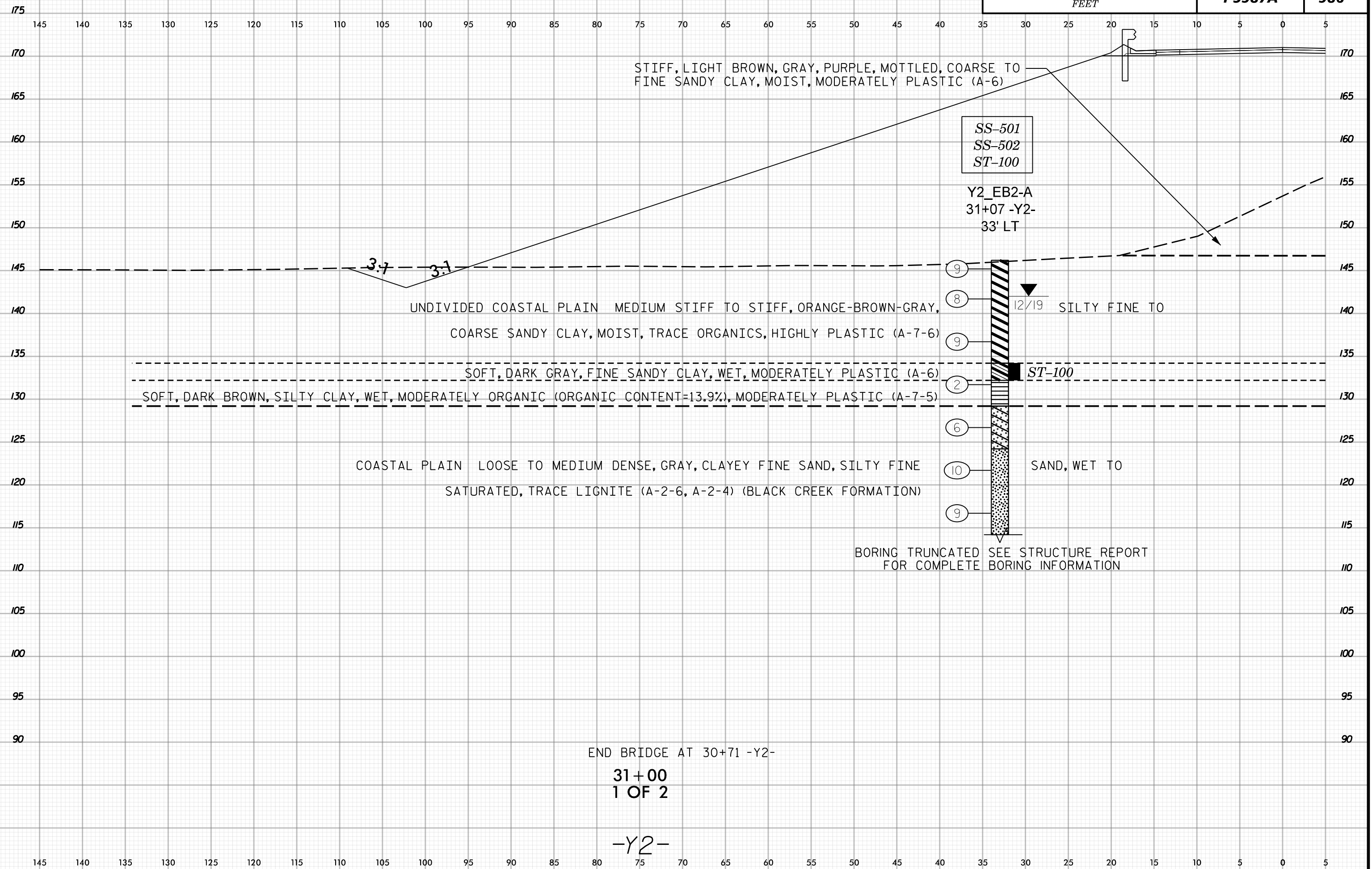
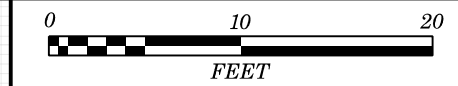

END BRIDGE AT 30+71 -Y2-  
31+00  
1 OF 2

-Y2-

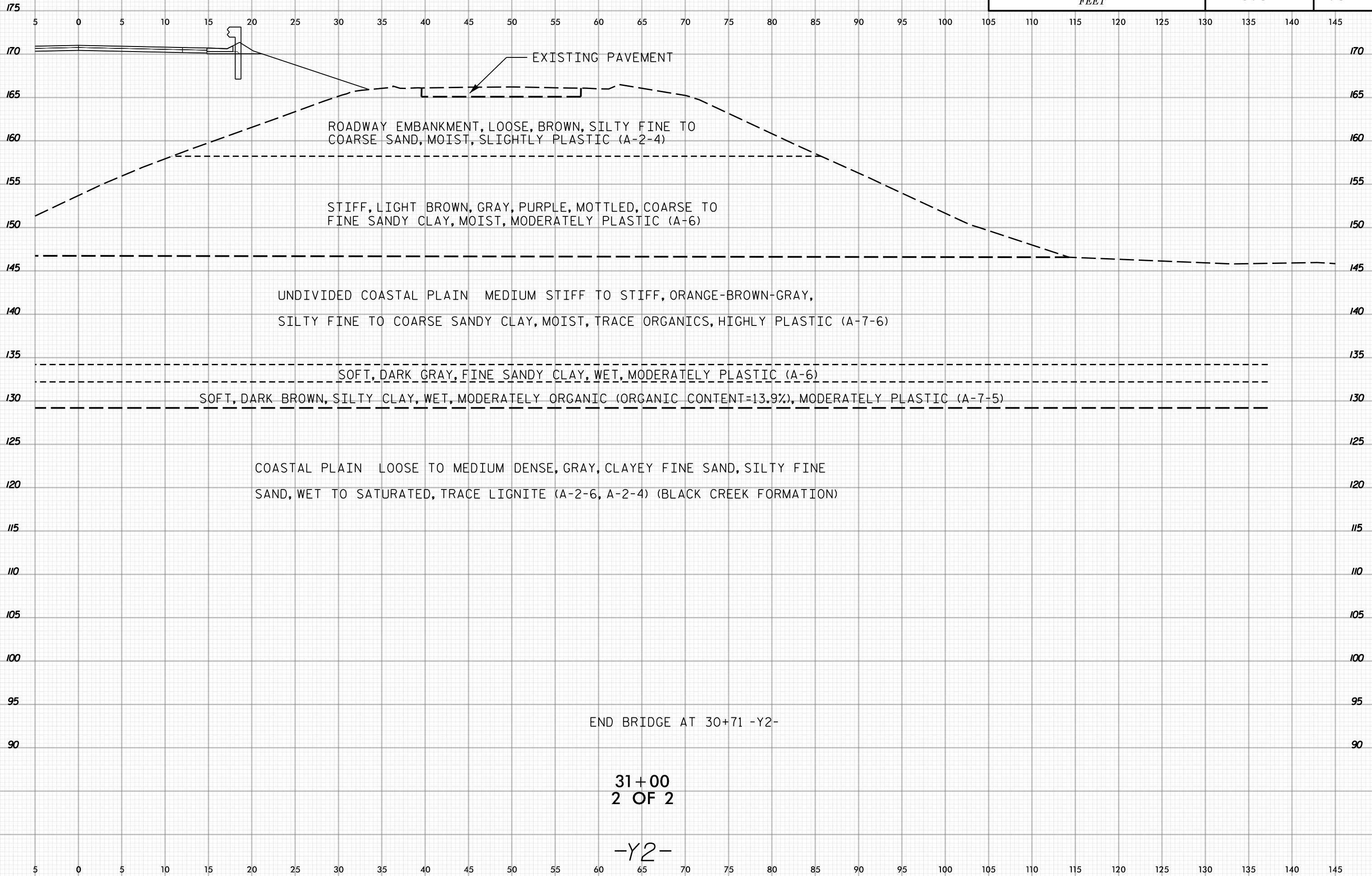
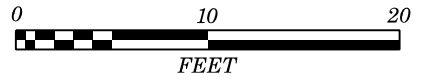

EXISTING PAVEMENT

ROADWAY EMBANKMENT, LOOSE, BROWN, SILTY FINE TO COARSE SAND, MOIST, SLIGHTLY PLASTIC (A-2-4)

STIFF, LIGHT BROWN, GRAY, PURPLE, MOTTLED, COARSE TO FINE SANDY CLAY, MOIST, MODERATELY PLASTIC (A-6)

UNDIVIDED COASTAL PLAIN MEDIUM STIFF TO STIFF, ORANGE-BROWN-GRAY, SILTY FINE TO COARSE SANDY CLAY, MOIST, TRACE ORGANICS, HIGHLY PLASTIC (A-7-6)

SOFT, DARK GRAY, FINE SANDY CLAY, WET, MODERATELY PLASTIC (A-6)

SOFT, DARK BROWN, SILTY CLAY, WET, MODERATELY ORGANIC (ORGANIC CONTENT=13.9%), MODERATELY PLASTIC (A-7-5)

COASTAL PLAIN LOOSE TO MEDIUM DENSE, GRAY, CLAYEY FINE SAND, SILTY FINE SAND, WET TO SATURATED, TRACE LIGNITE (A-2-6, A-2-4) (BLACK CREEK FORMATION)

END BRIDGE AT 30+71 -Y2-

31+00  
2 OF 2

-Y2-

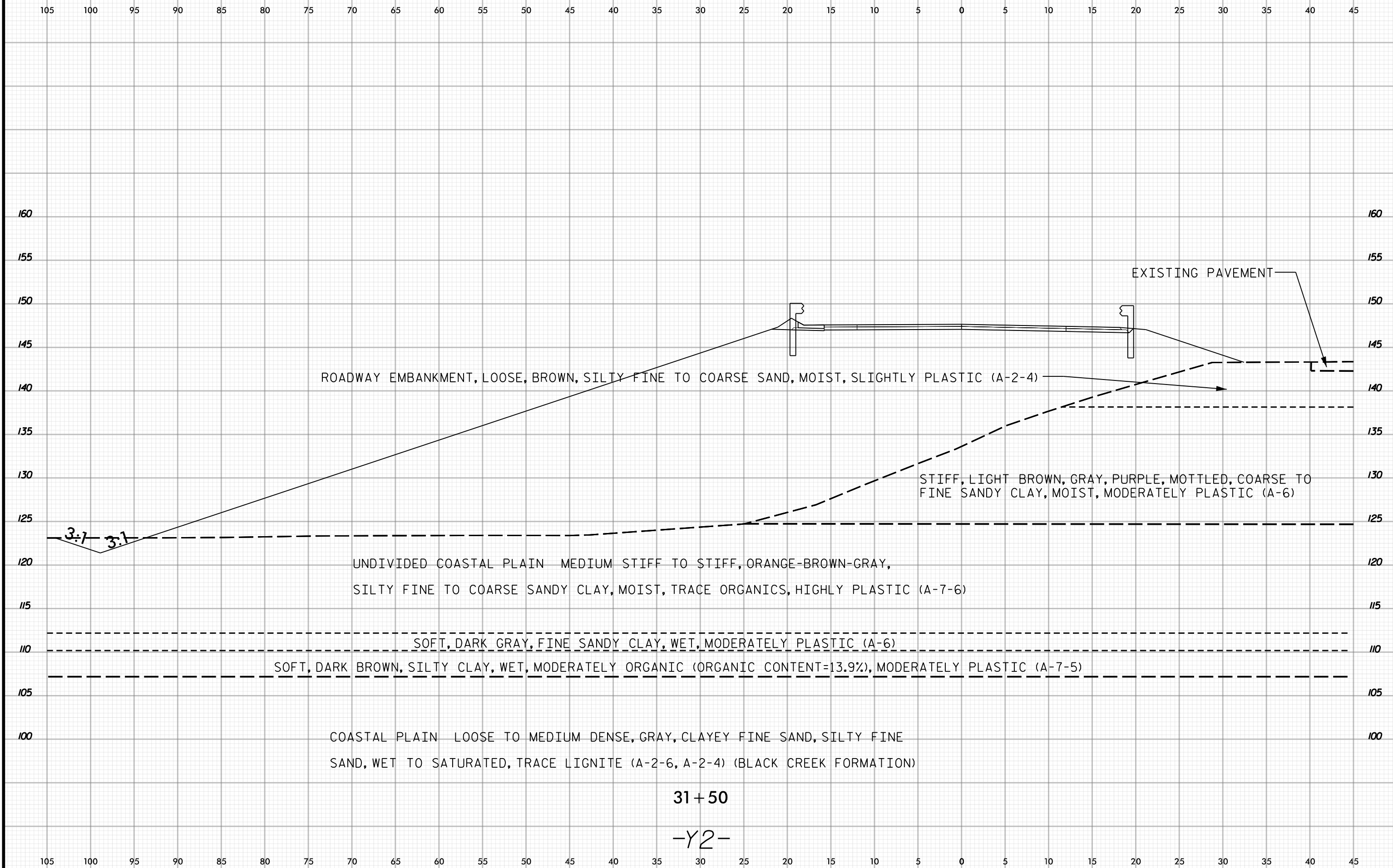
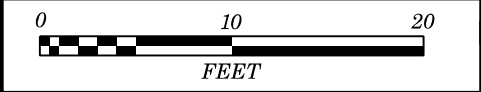

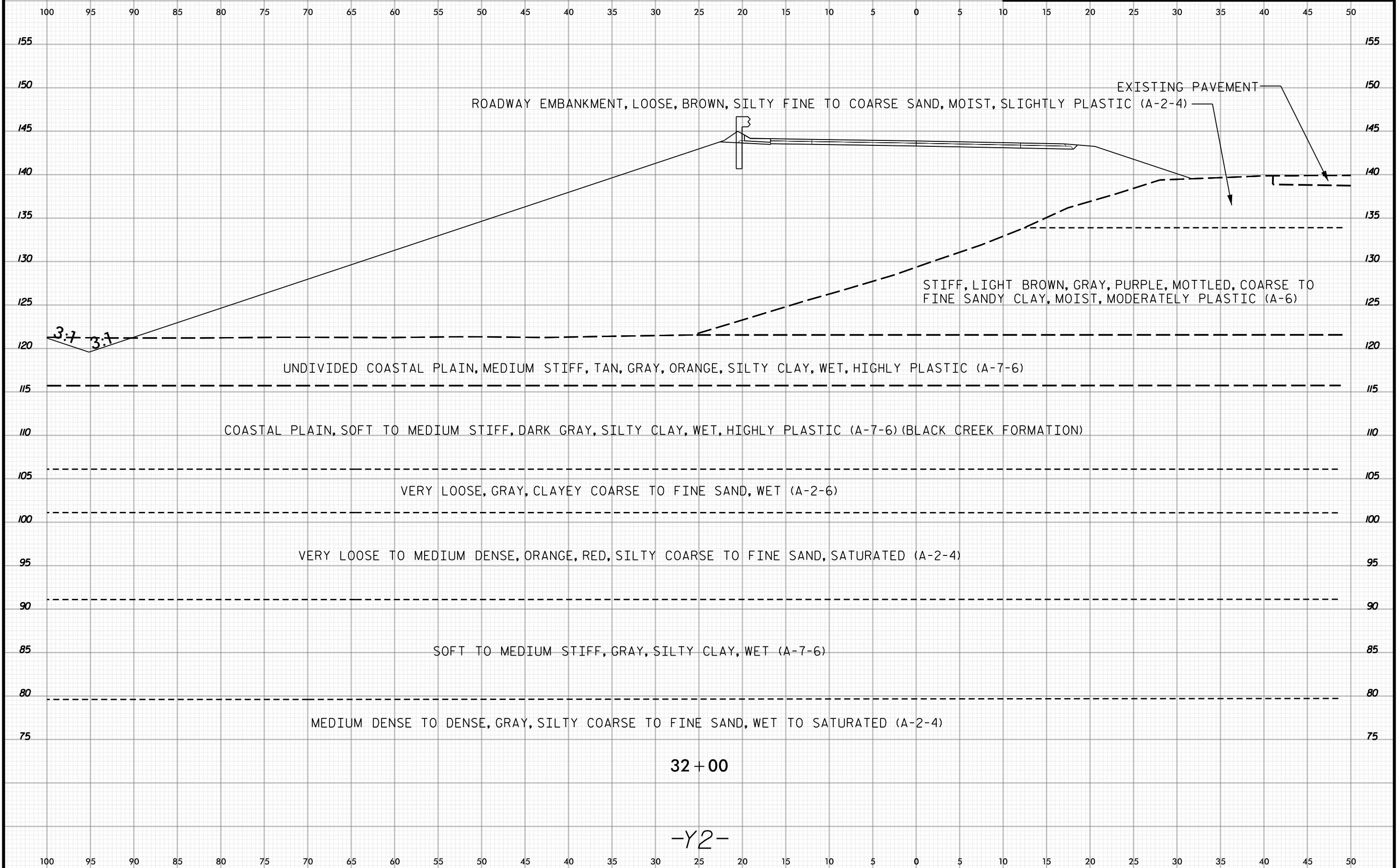
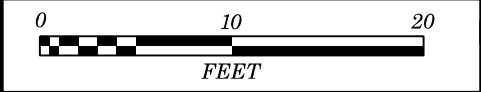



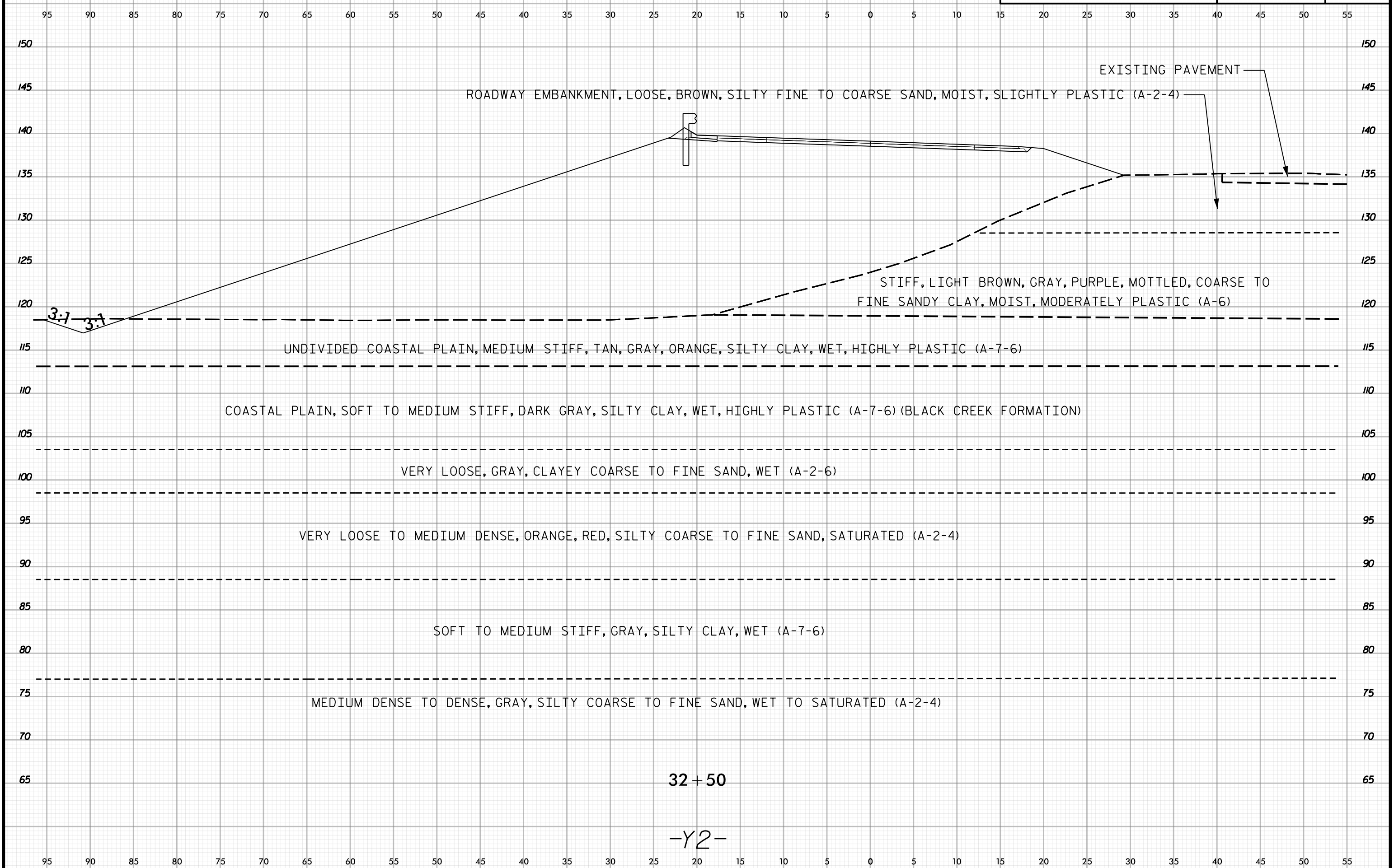

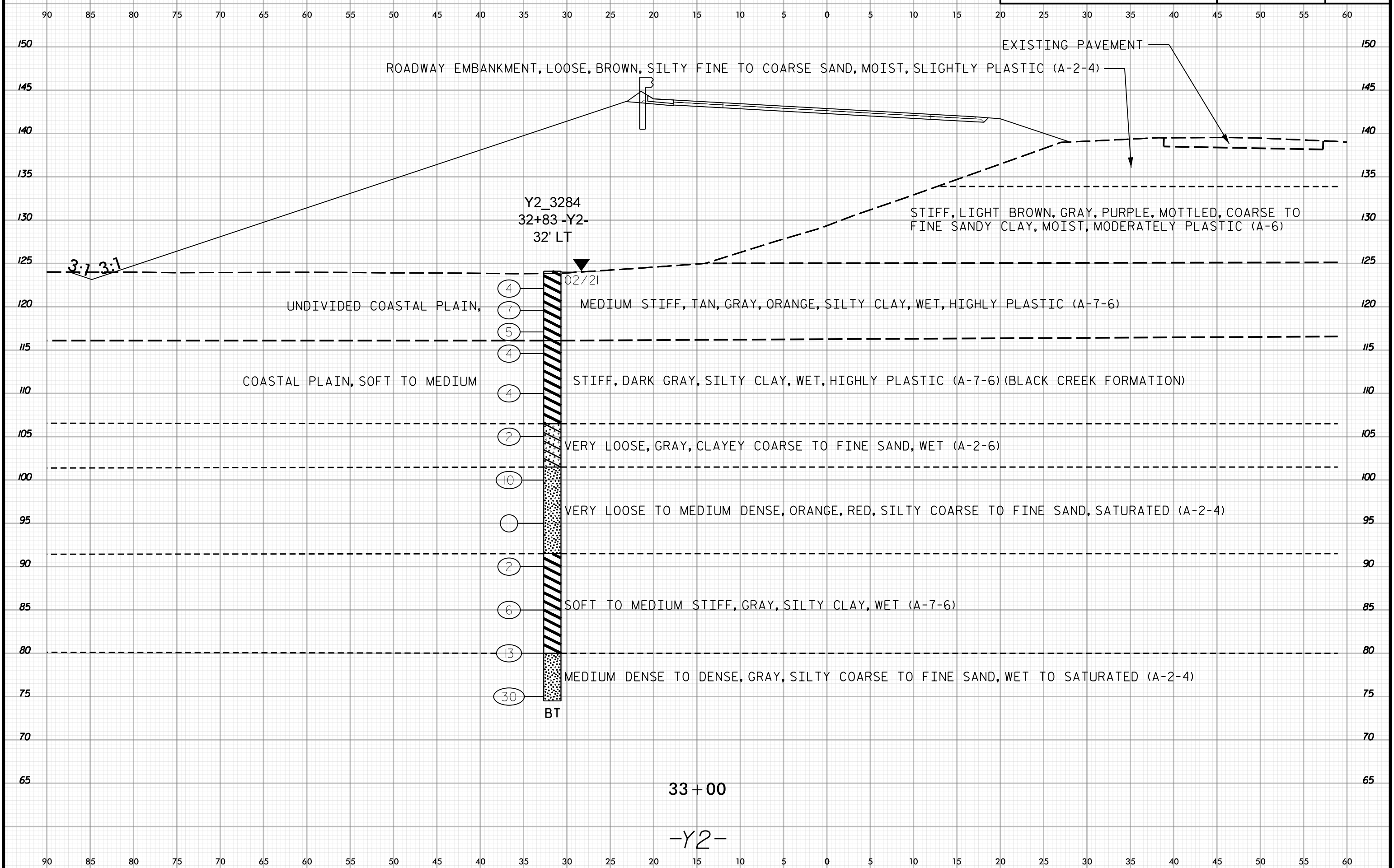
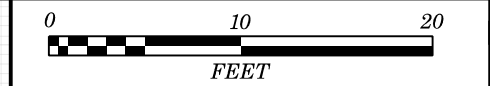

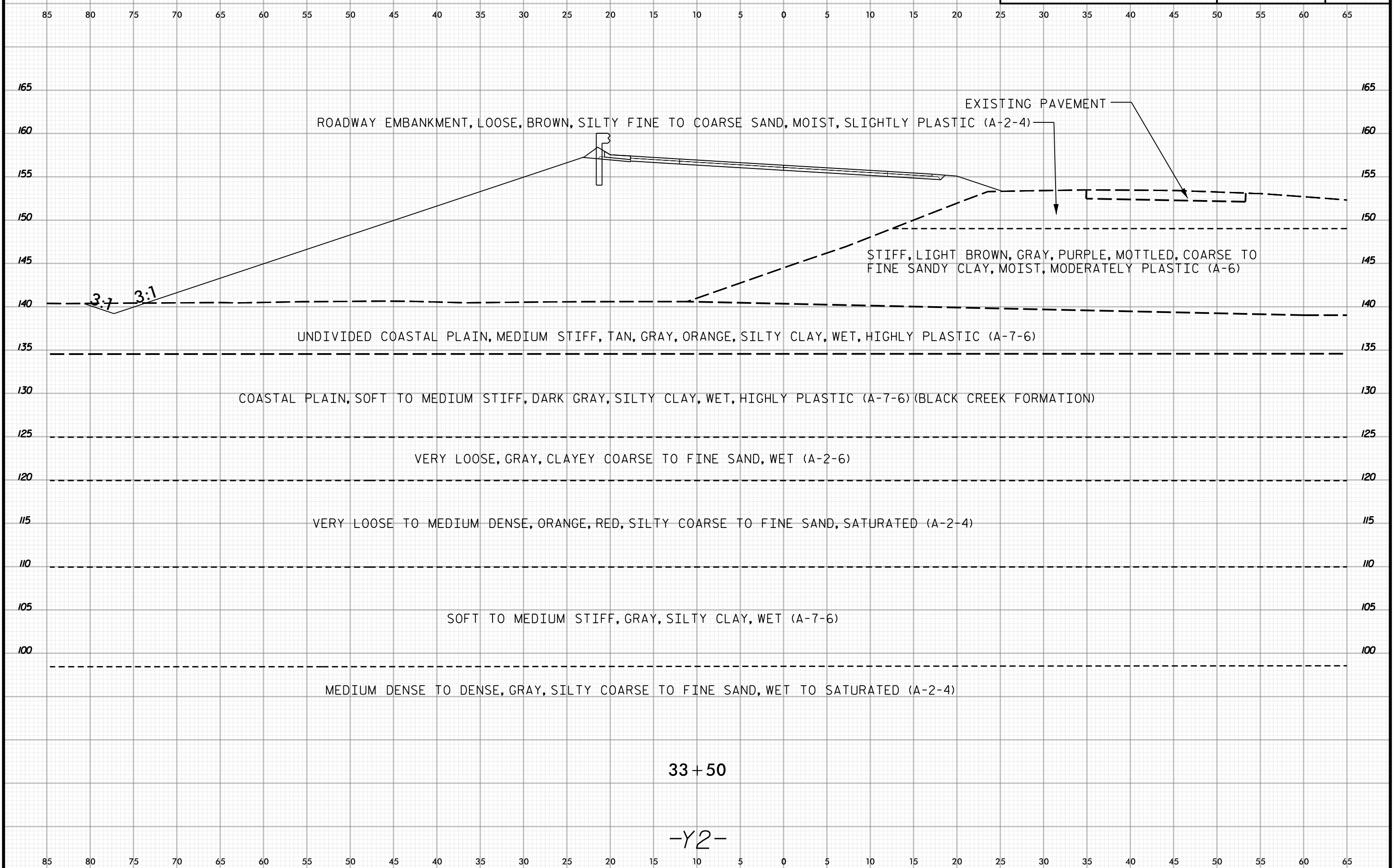

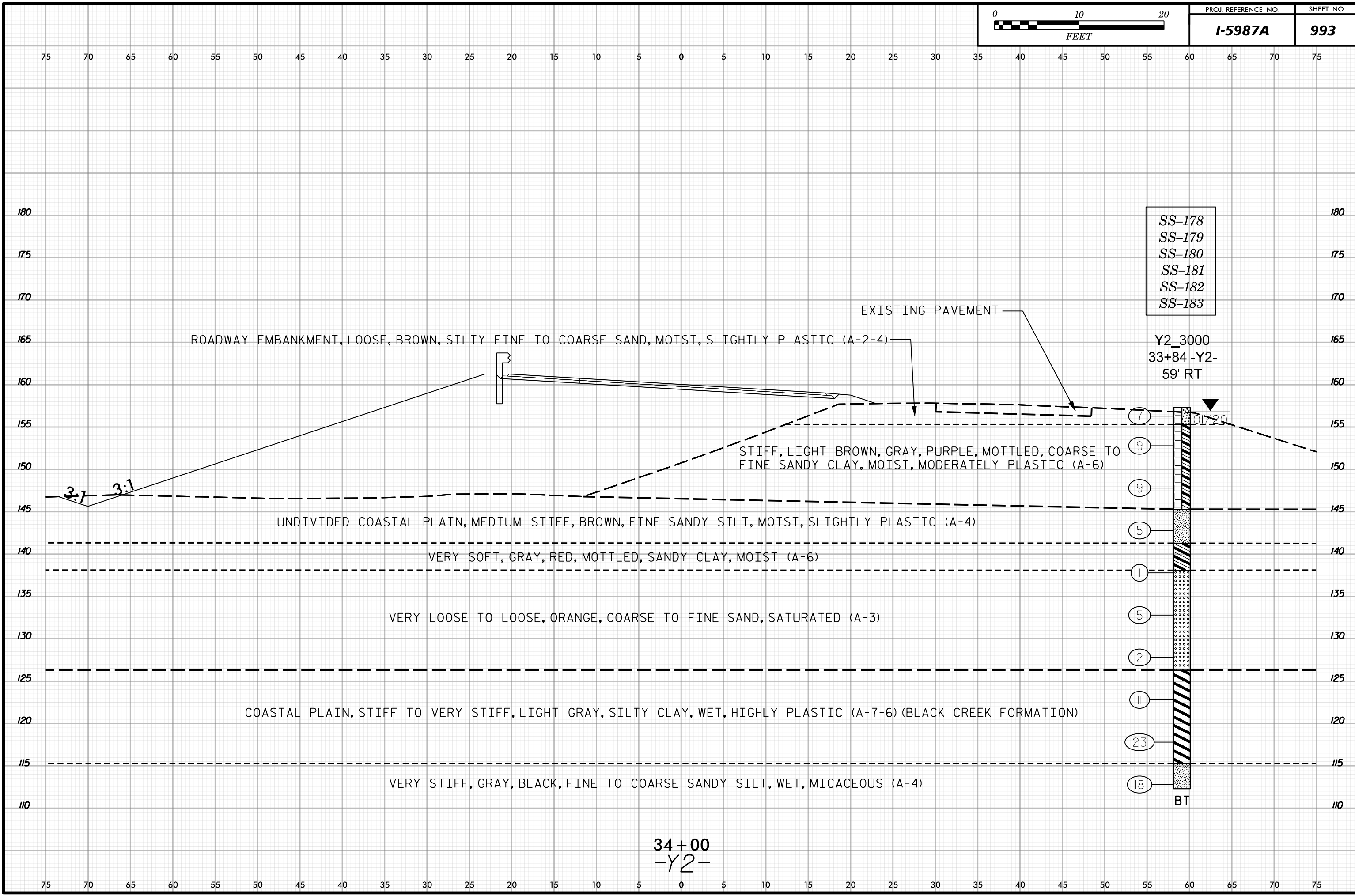
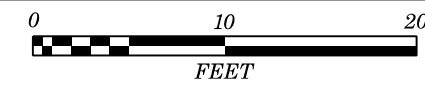

34+00  
-Y2-

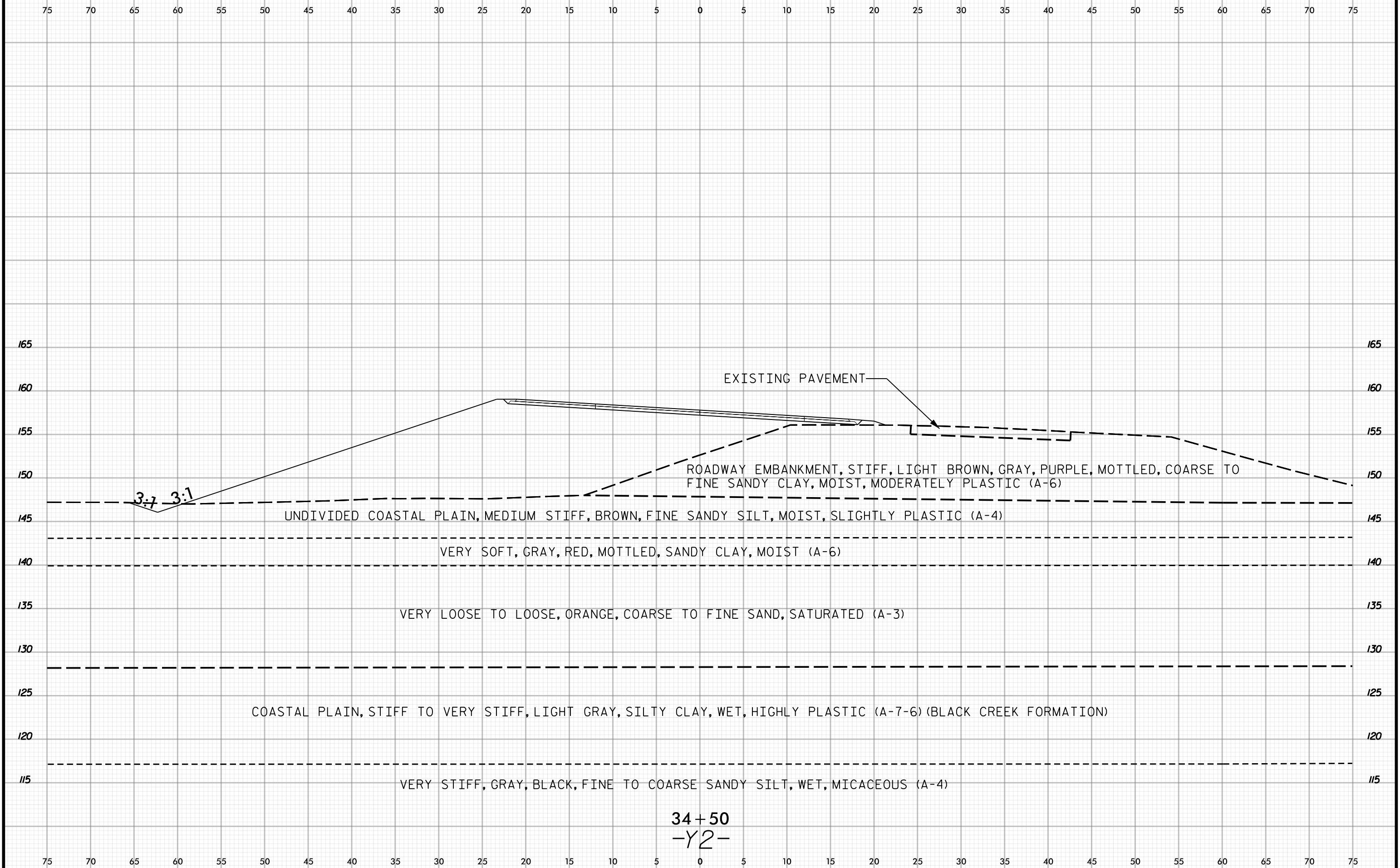

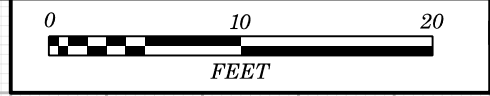

75 70 65 60 55 50 45 40 35 30 25 20 15 10 5 0 5 10 15 20 25 30 35 40 45 50 55 60 65 70 75

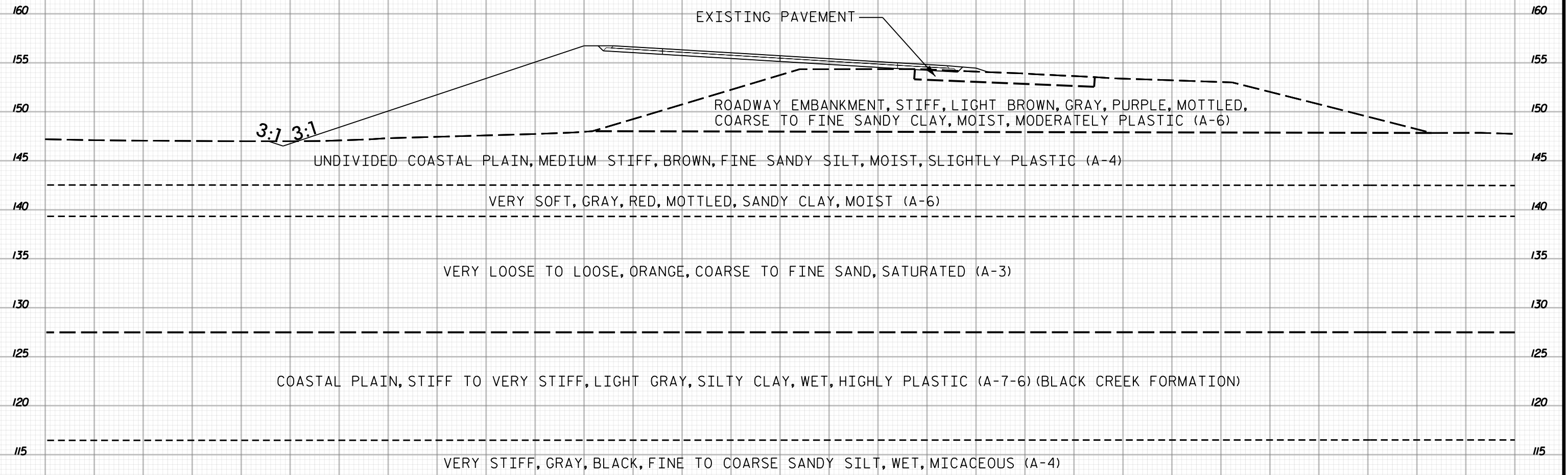

35+00  
-Y2-

75 70 65 60 55 50 45 40 35 30 25 20 15 10 5 0 5 10 15 20 25 30 35 40 45 50 55 60 65 70 75

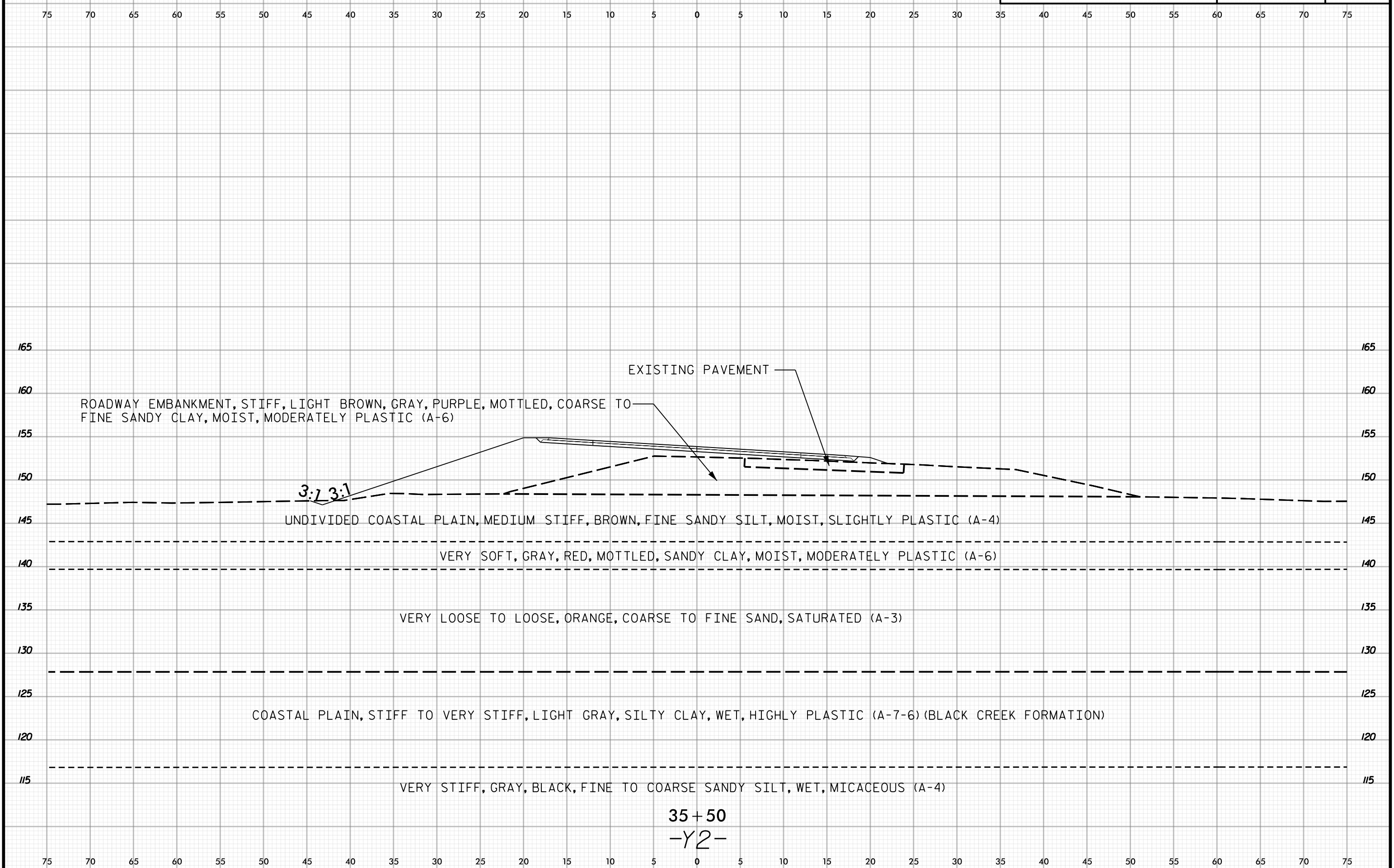
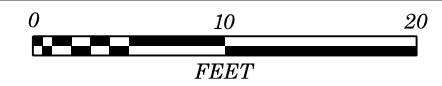

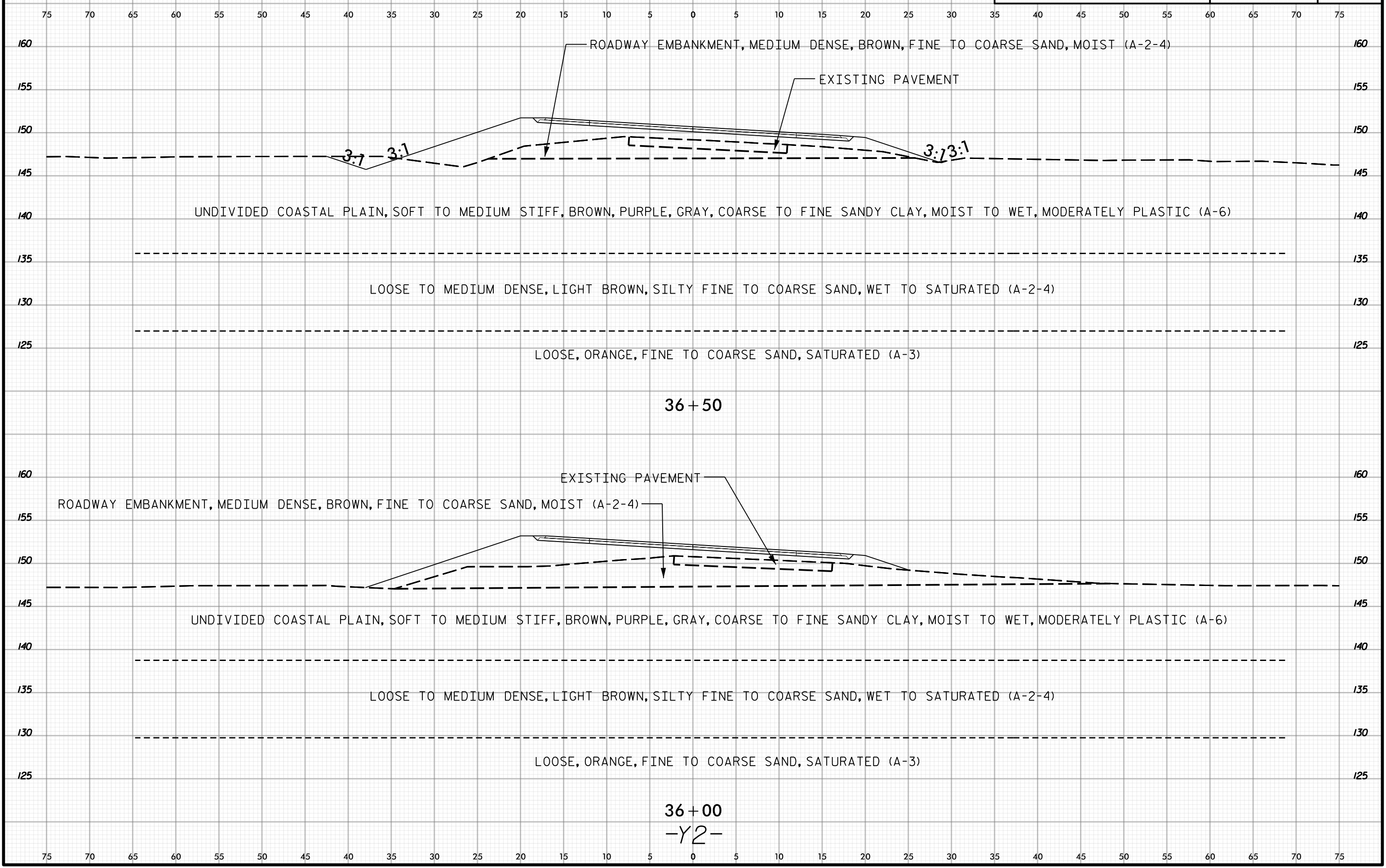



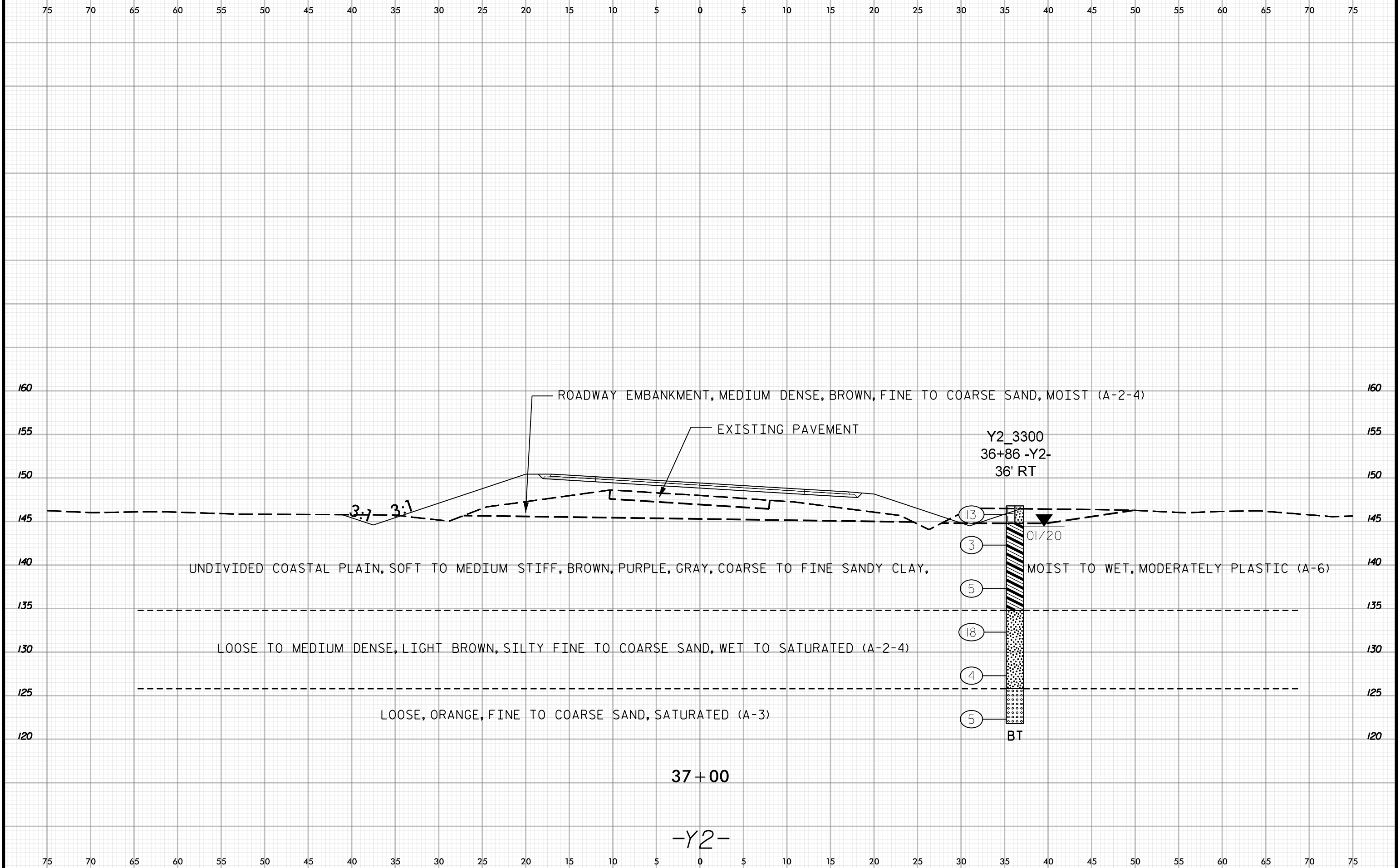
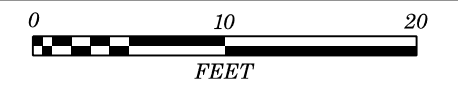

37+00

-Y2-

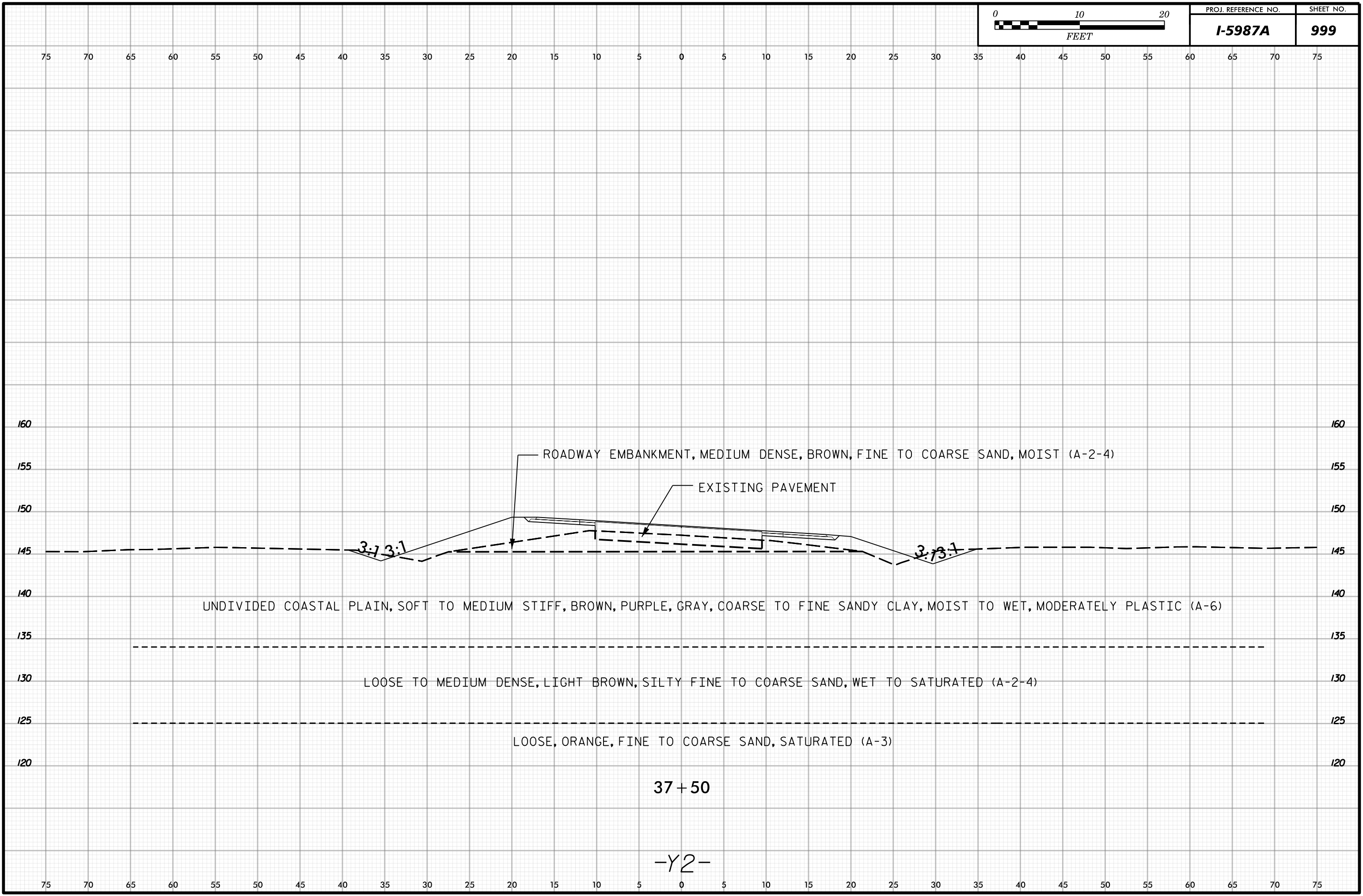

37+50

-Y2-

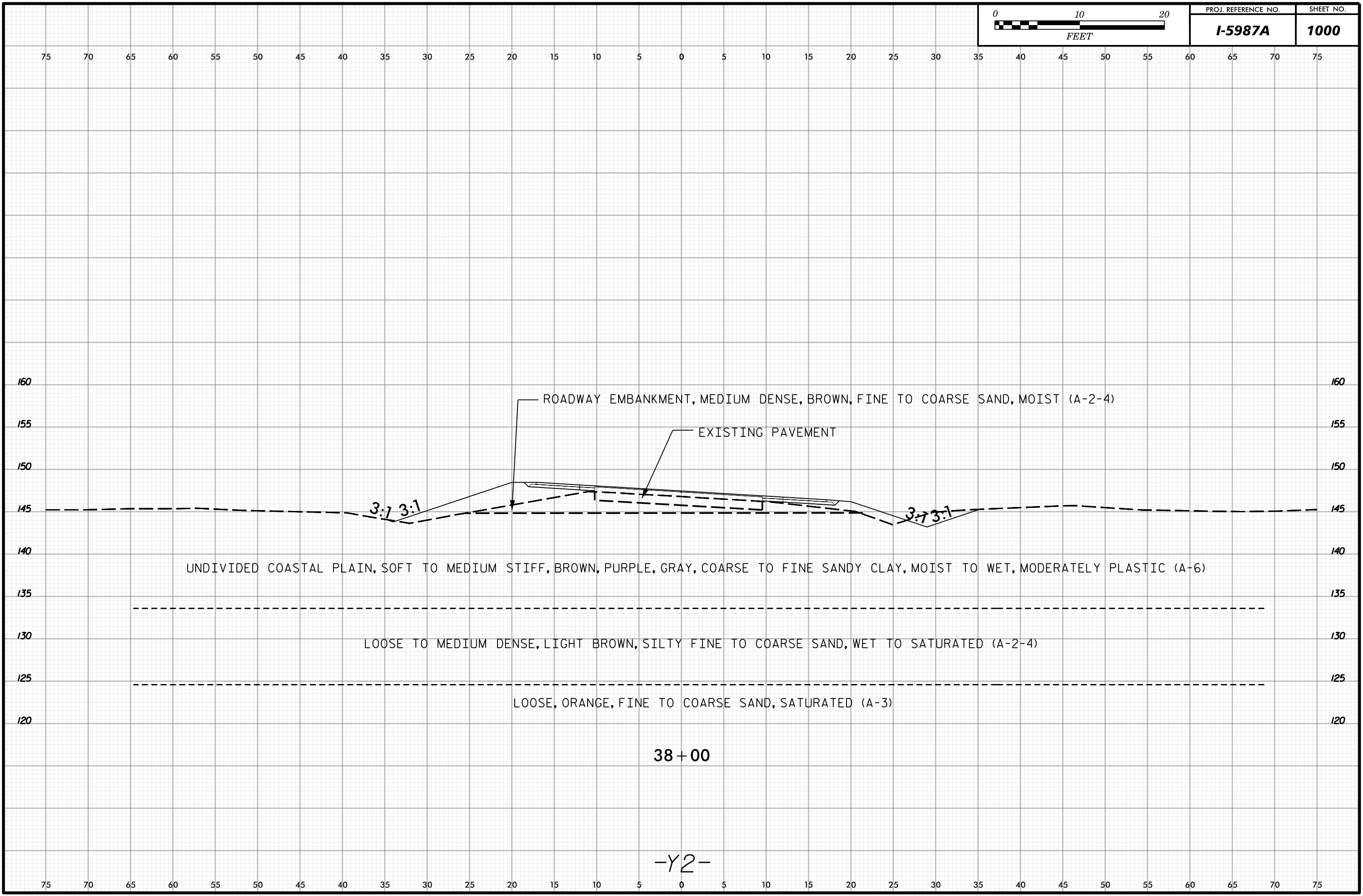

ROADWAY EMBANKMENT, MEDIUM DENSE, BROWN, FINE TO COARSE SAND, MOIST (A-2-4)

EXISTING PAVEMENT

3:1 3:1

3:1 3:1

UNDIVIDED COASTAL PLAIN, SOFT TO MEDIUM STIFF, BROWN, PURPLE, GRAY, COARSE TO FINE SANDY CLAY, MOIST TO WET, MODERATELY PLASTIC (A-6)

LOOSE TO MEDIUM DENSE, LIGHT BROWN, SILTY FINE TO COARSE SAND, WET TO SATURATED (A-2-4)

LOOSE, ORANGE, FINE TO COARSE SAND, SATURATED (A-3)

38+00

-Y2-

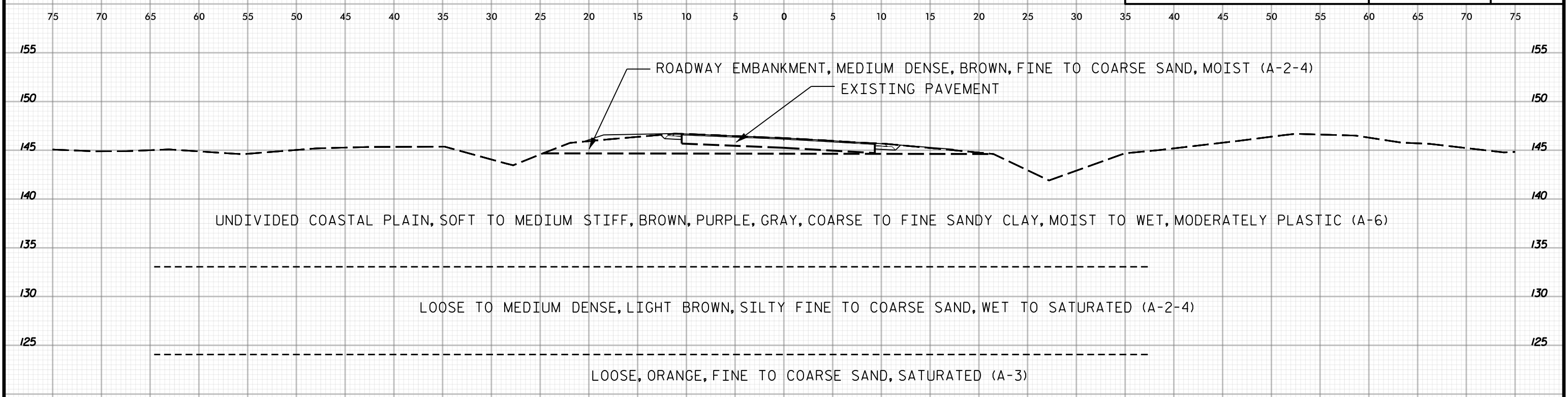

39+00

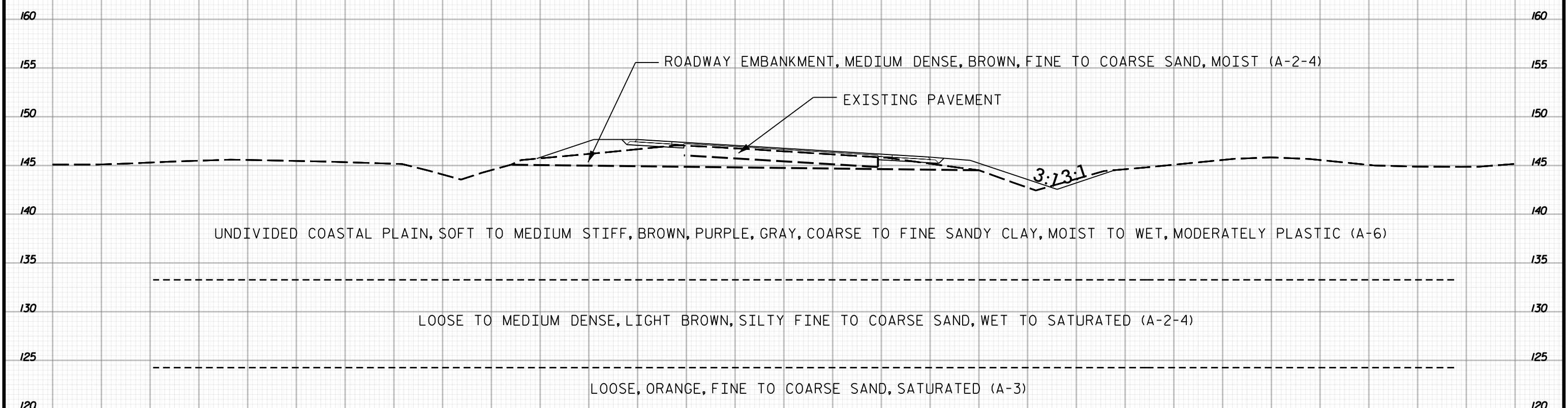

38+50  
-Y2-

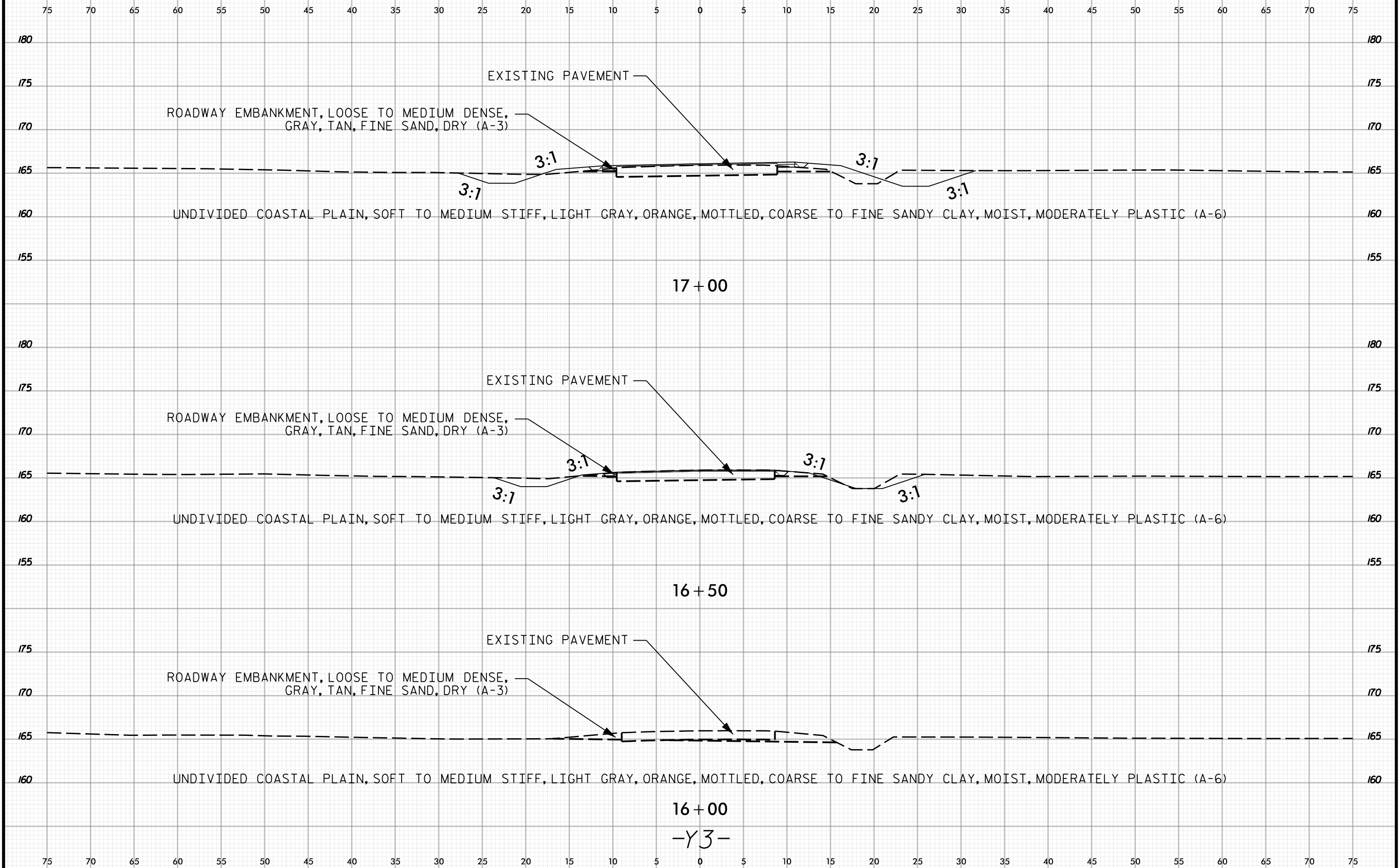
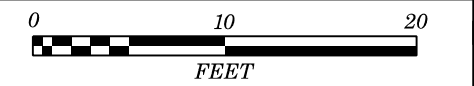

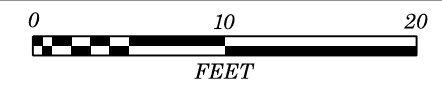

75 70 65 60 55 50 45 40 35 30 25 20 15 10 5 0 5 10 15 20 25 30 35 40 45 50 55 60 65 70 75

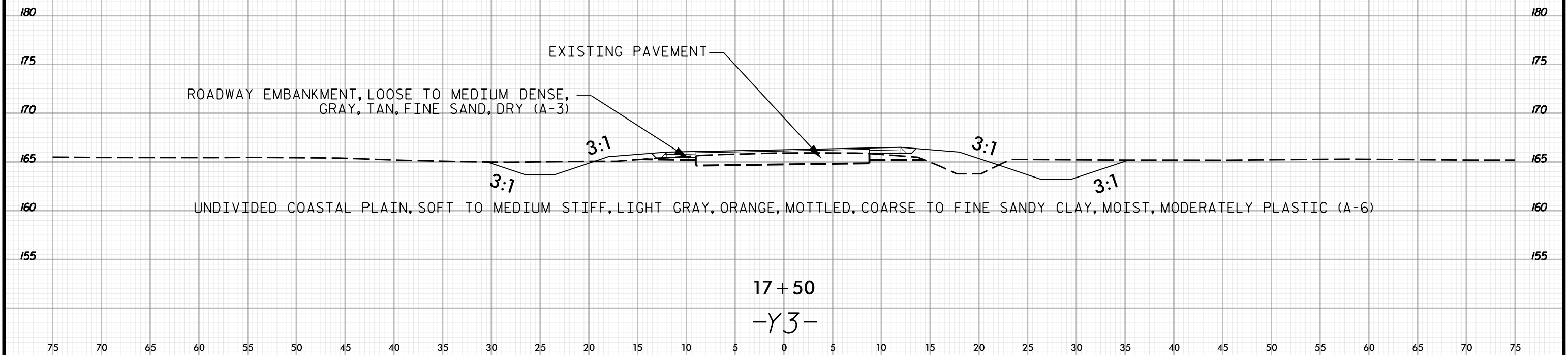
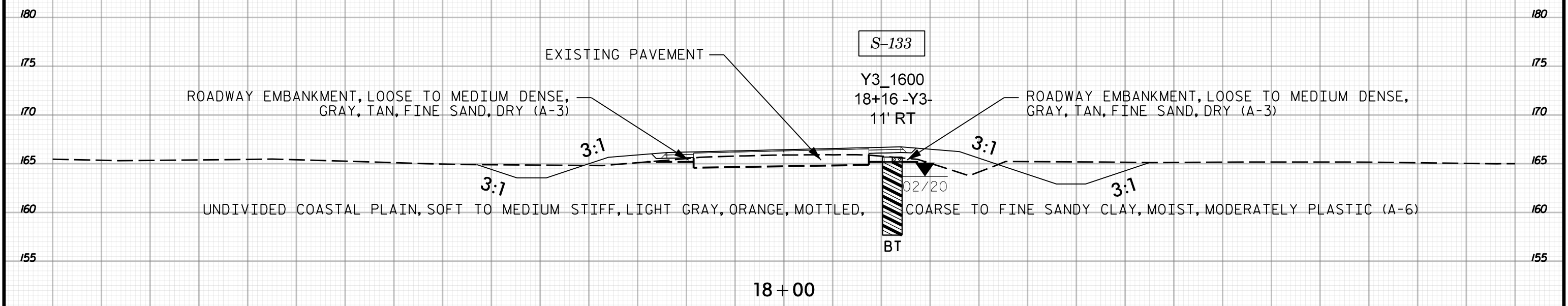

75 70 65 60 55 50 45 40 35 30 25 20 15 10 5 0 5 10 15 20 25 30 35 40 45 50 55 60 65 70 75

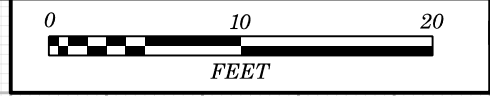

75 70 65 60 55 50 45 40 35 30 25 20 15 10 5 0 5 10 15 20 25 30 35 40 45 50 55 60 65 70 75

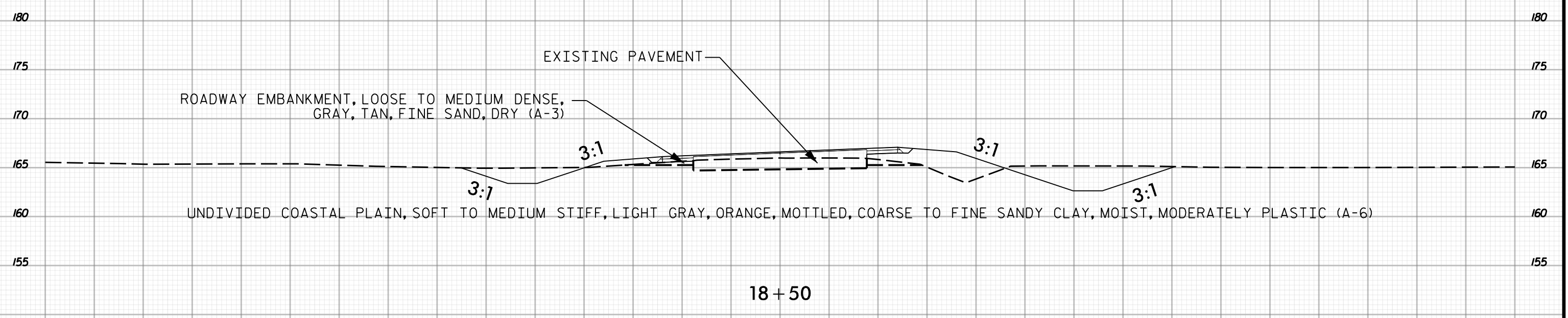
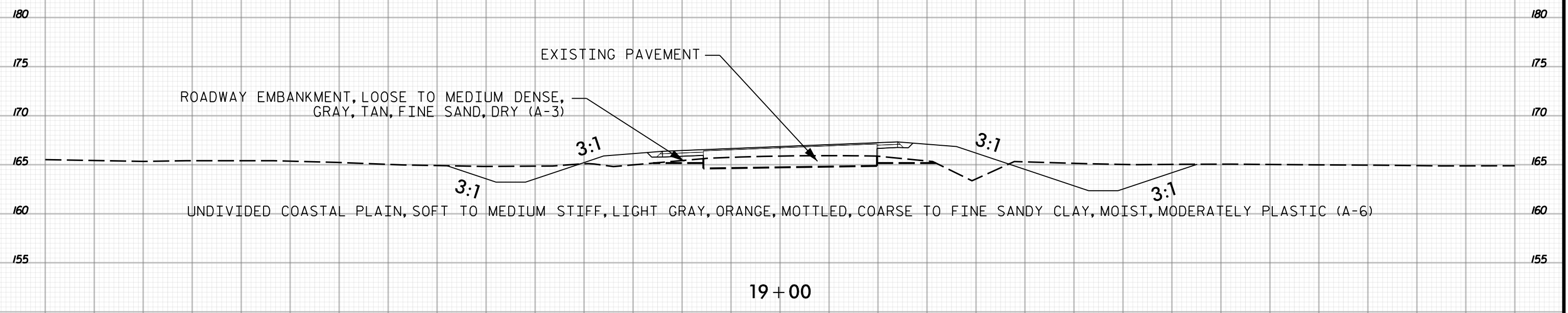

75 70 65 60 55 50 45 40 35 30 25 20 15 10 5 0 5 10 15 20 25 30 35 40 45 50 55 60 65 70 75

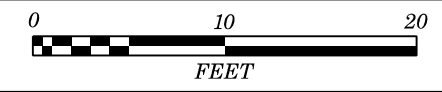

75 70 65 60 55 50 45 40 35 30 25 20 15 10 5 0 5 10 15 20 25 30 35 40 45 50 55 60 65 70 75

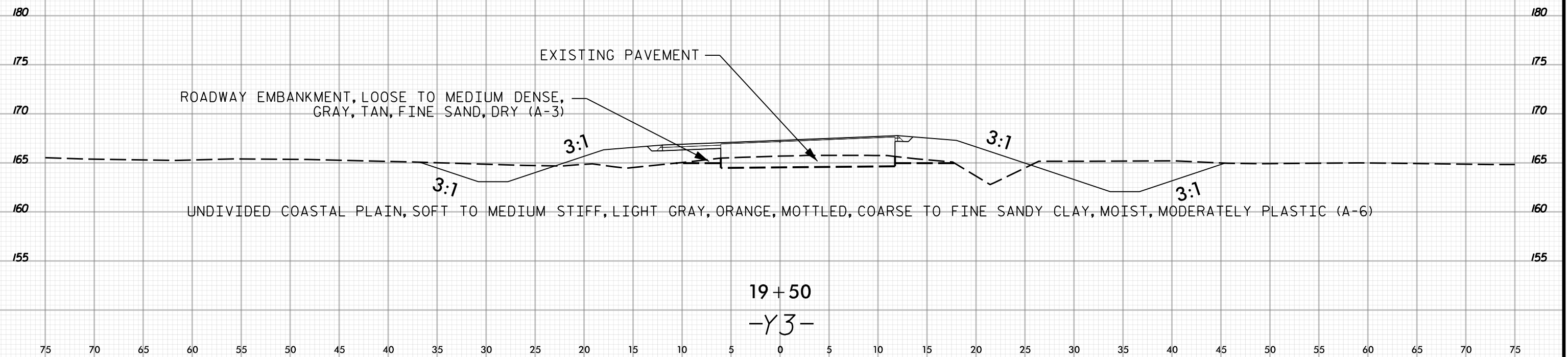
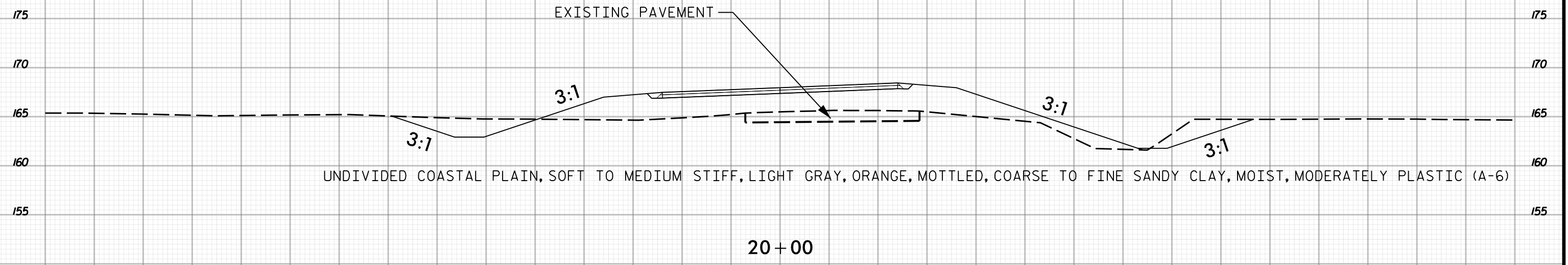

75 70 65 60 55 50 45 40 35 30 25 20 15 10 5 0 5 10 15 20 25 30 35 40 45 50 55 60 65 70 75



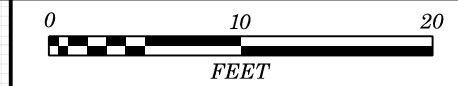

75 70 65 60 55 50 45 40 35 30 25 20 15 10 5 0 5 10 15 20 25 30 35 40 45 50 55 60 65 70 75

EXISTING PAVEMENT

Y3\_2115  
21+16 -Y3-  
16' LT

3:1

3:1

02/21

4

6

6

8

10

11

BT

UNDIVIDED COASTAL PLAIN,

SOFT TO MEDIUM STIFF, ORANGE, GRAY, COARSE TO FINE SANDY CLAY, WET, MODERATELY PLASTIC (A-6)

LOOSE TO MEDIUM DENSE, ORANGE, GRAY, SILTY COARSE TO FINE SAND, WET (A-2-4)

21+00

EXISTING PAVEMENT

3:1

3:1

3:1

3:1

UNDIVIDED COASTAL PLAIN, SOFT TO MEDIUM STIFF, LIGHT GRAY, ORANGE, MOTTLED, COARSE TO FINE SANDY CLAY, MOIST, MODERATELY PLASTIC (A-6)

20+50

-Y3-

75 70 65 60 55 50 45 40 35 30 25 20 15 10 5 0 5 10 15 20 25 30 35 40 45 50 55 60 65 70 75

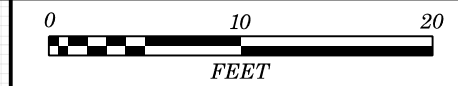

PROJ. REFERENCE NO.	SHEET NO.
I-5987A	1007

75 70 65 60 55 50 45 40 35 30 25 20 15 10 5 0 5 10 15 20 25 30 35 40 45 50 55 60 65 70 75

ROADWAY EMBANKMENT, LOOSE, TAN, ORANGE, GRAY, CLAYEY COARSE TO FINE SAND, SILTY COARSE TO FINE SAND, WET, SLIGHTLY PLASTIC, TRACE WOOD AND ROOT FRAGMENTS (A-2-6, A-2-4)

EXISTING PAVEMENT

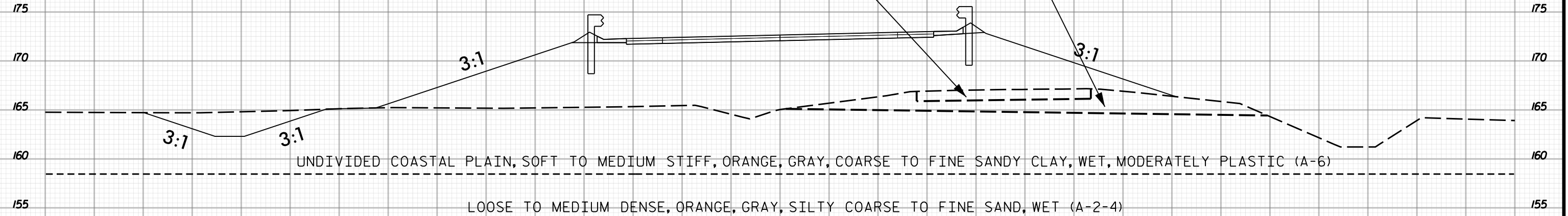

22+00

EXISTING PAVEMENT

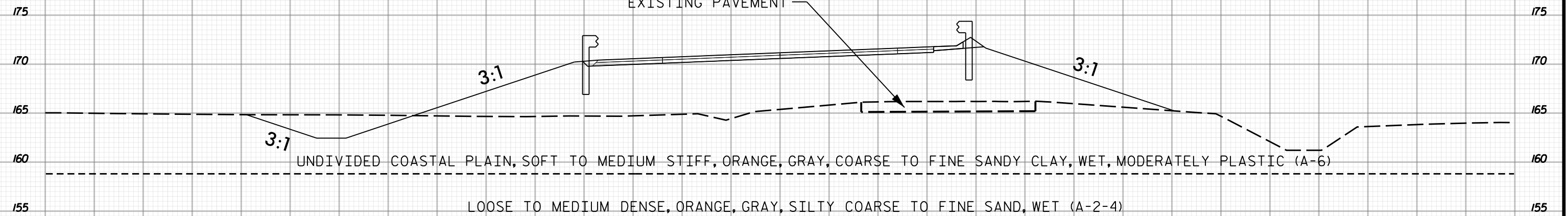

21+50

-Y3-

75 70 65 60 55 50 45 40 35 30 25 20 15 10 5 0 5 10 15 20 25 30 35 40 45 50 55 60 65 70 75

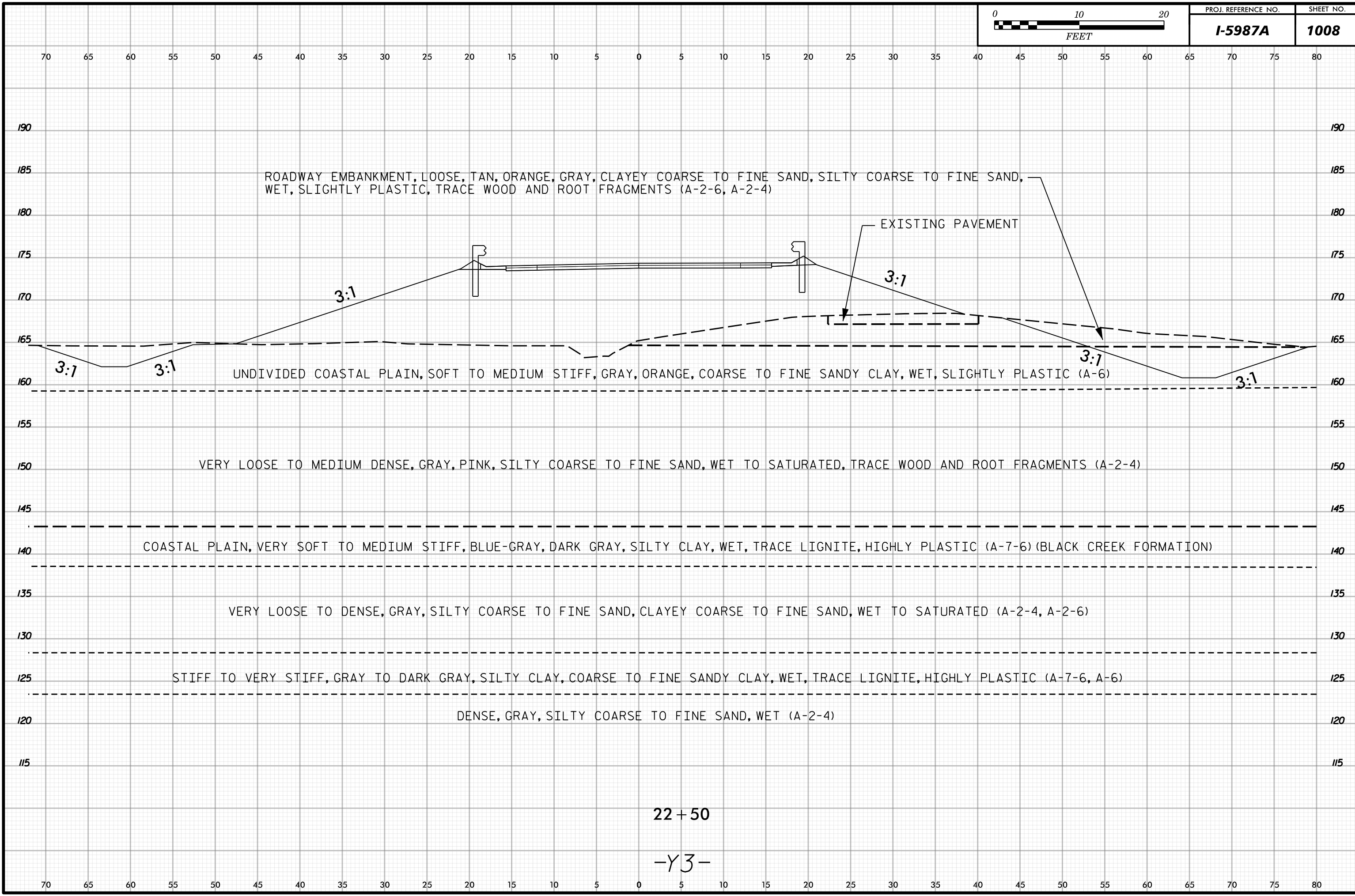

22 + 50

-Y3-

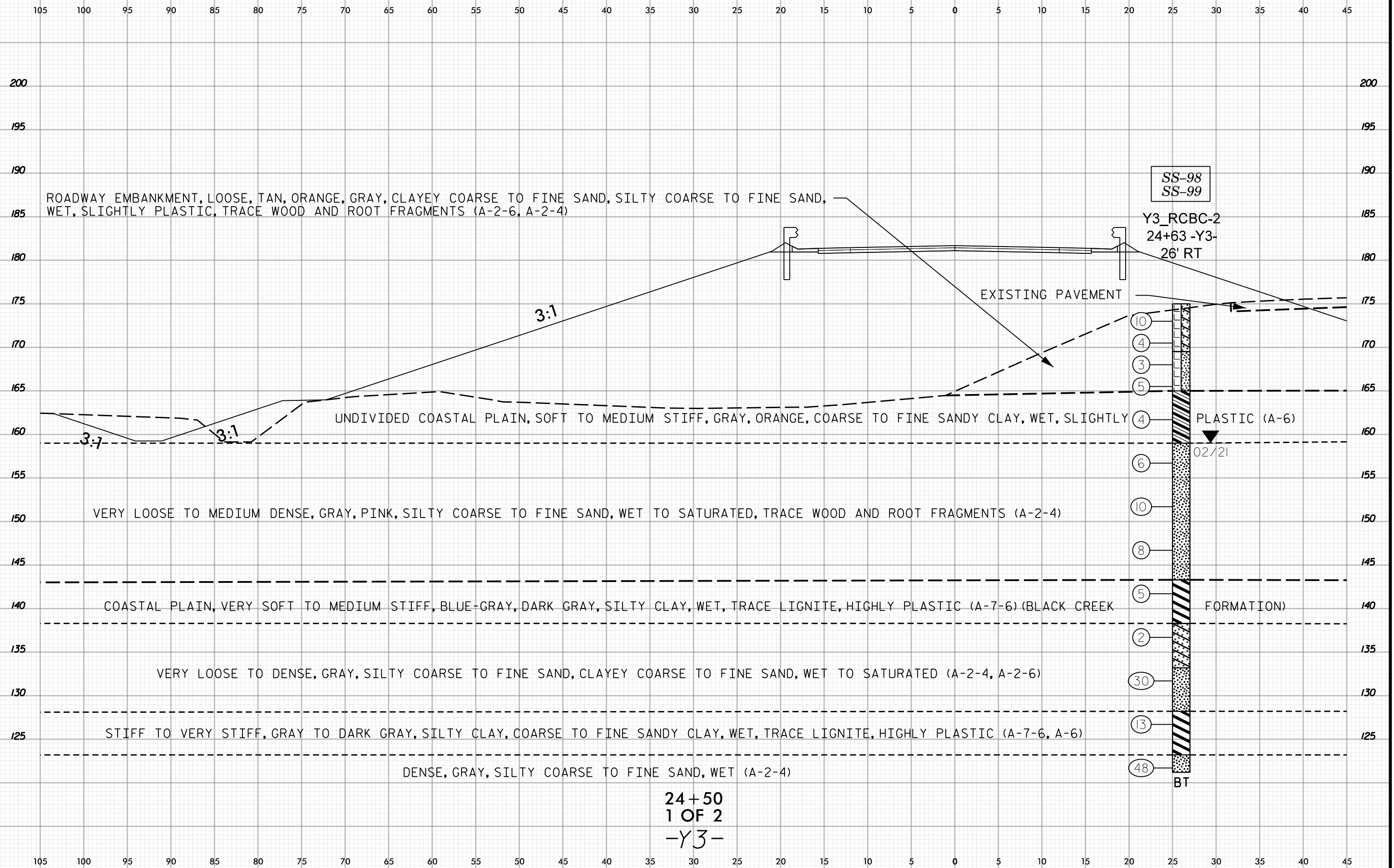
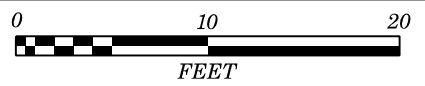

24+50  
 1 OF 2  
 -Y3-

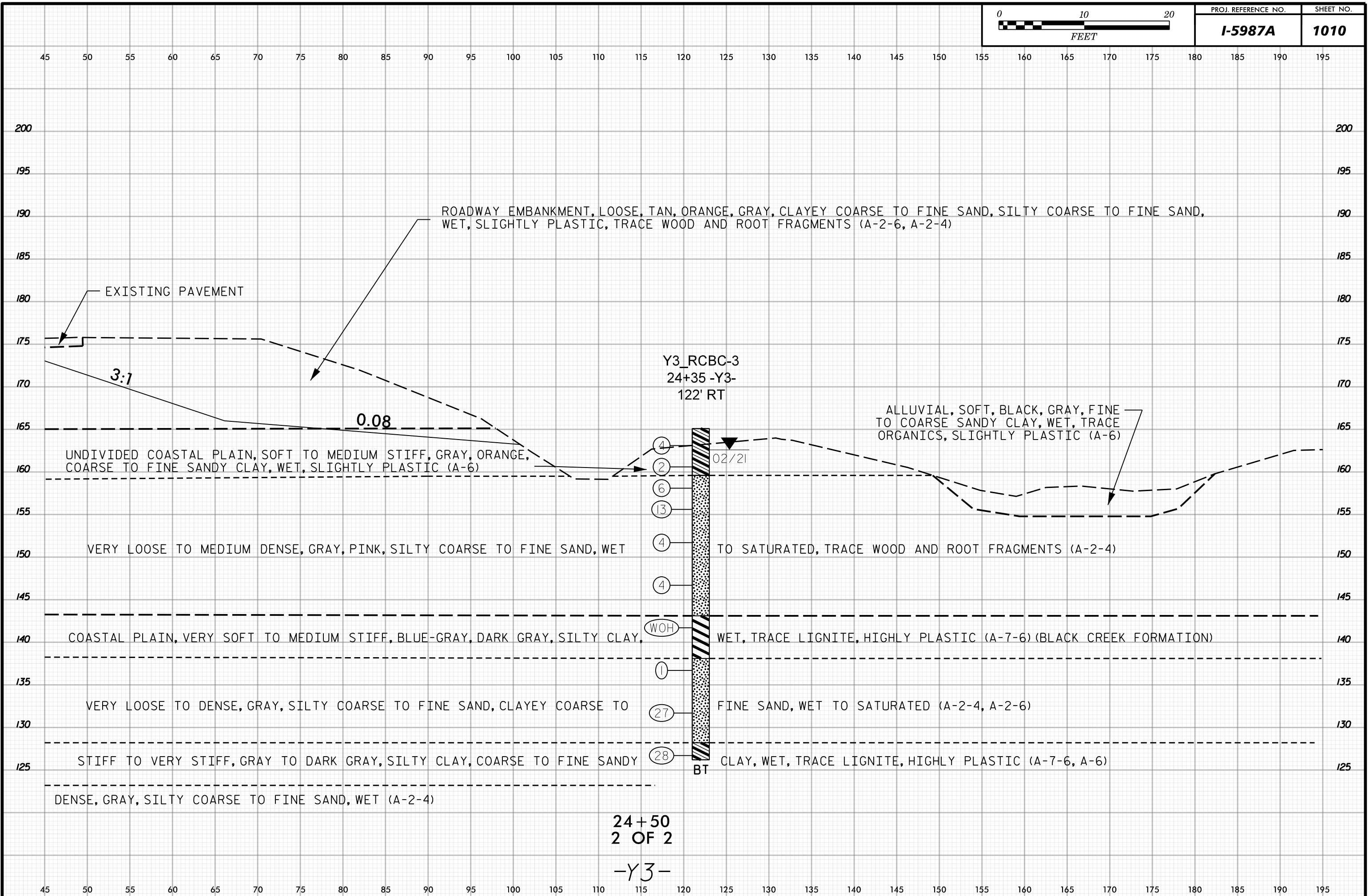
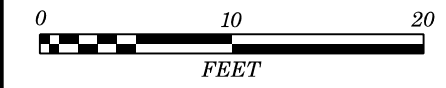

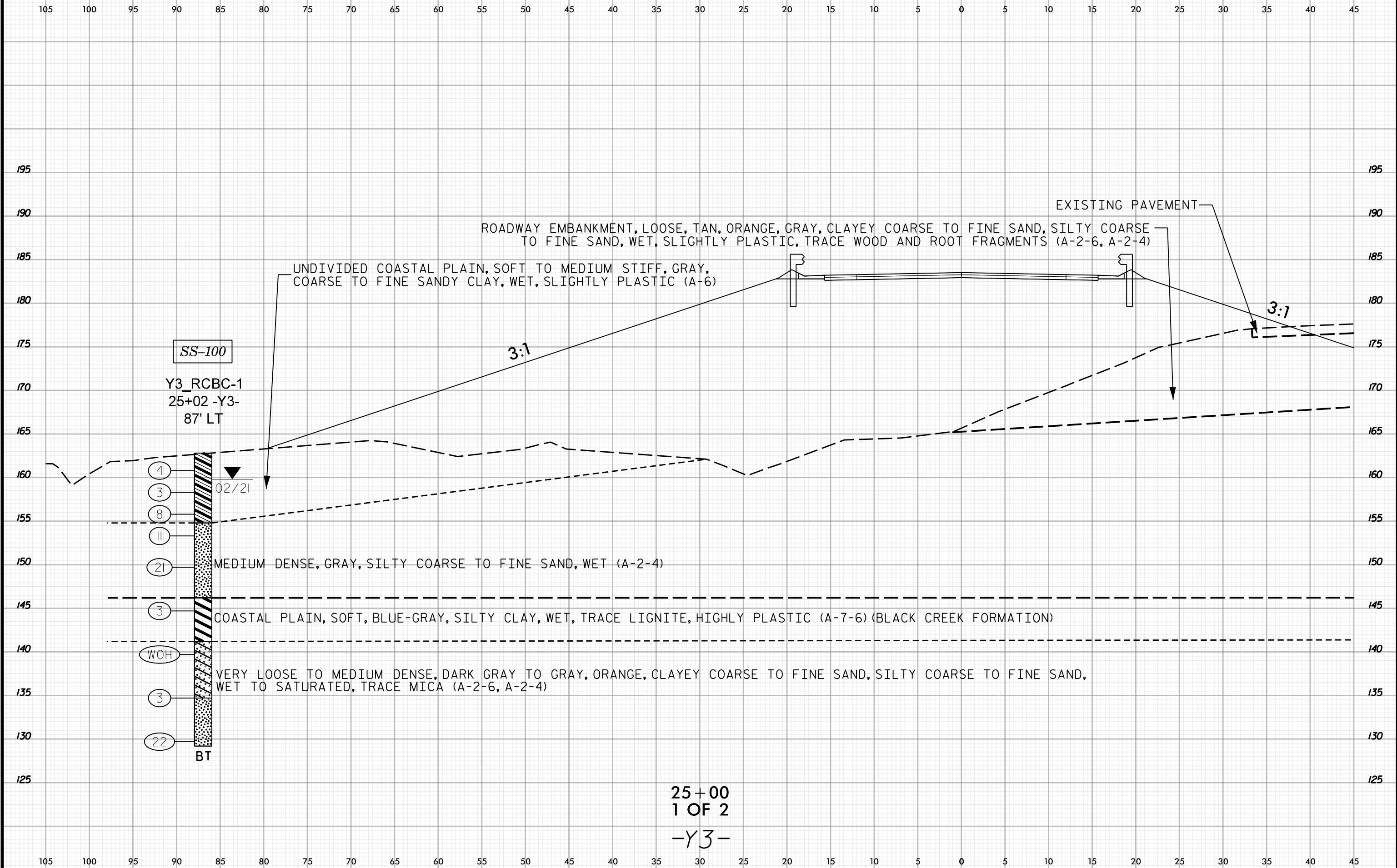
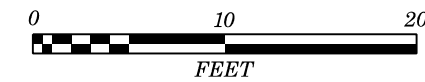



PROJ. REFERENCE NO.	SHEET NO.
I-5987A	1012

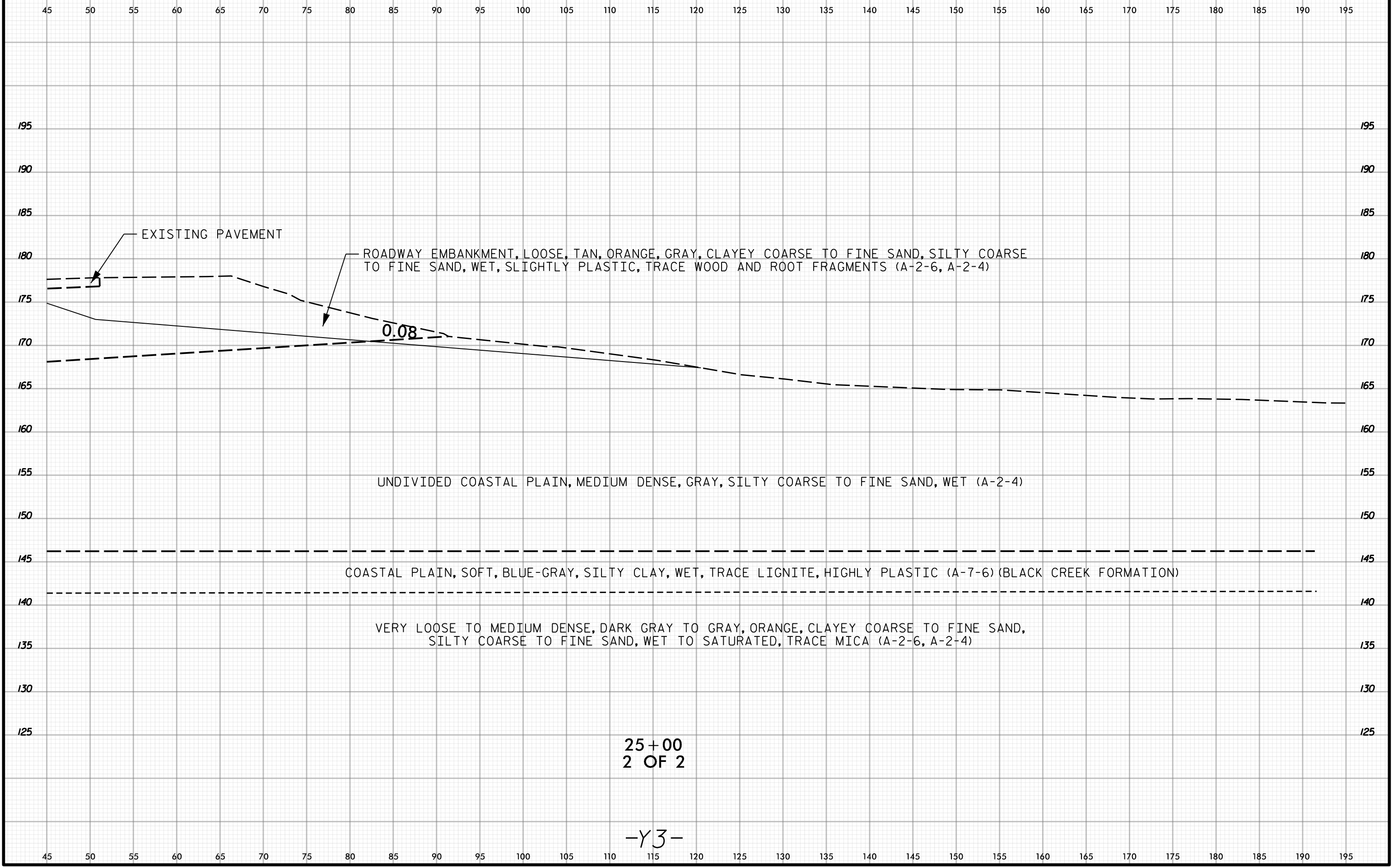

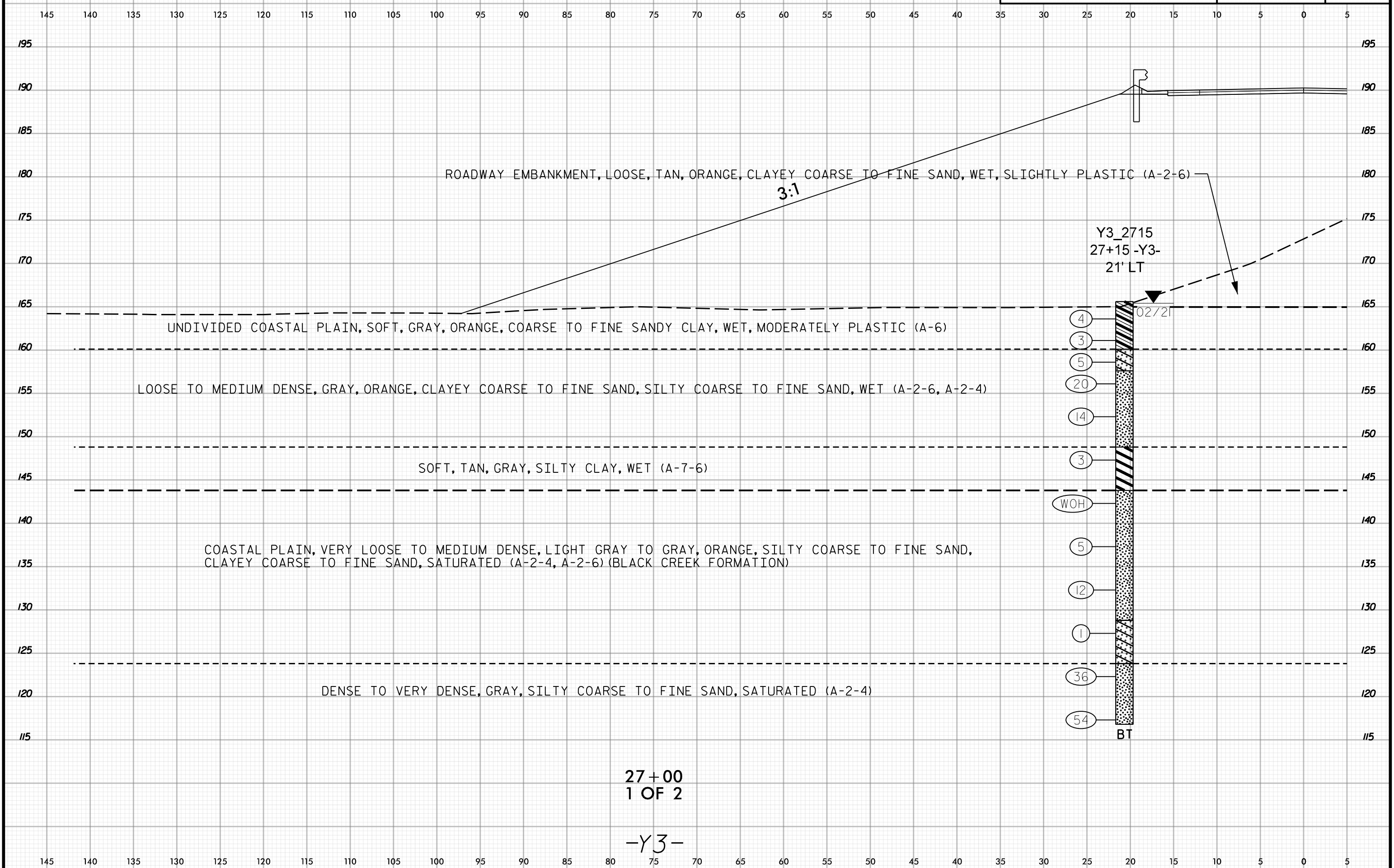
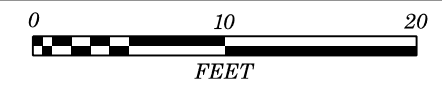



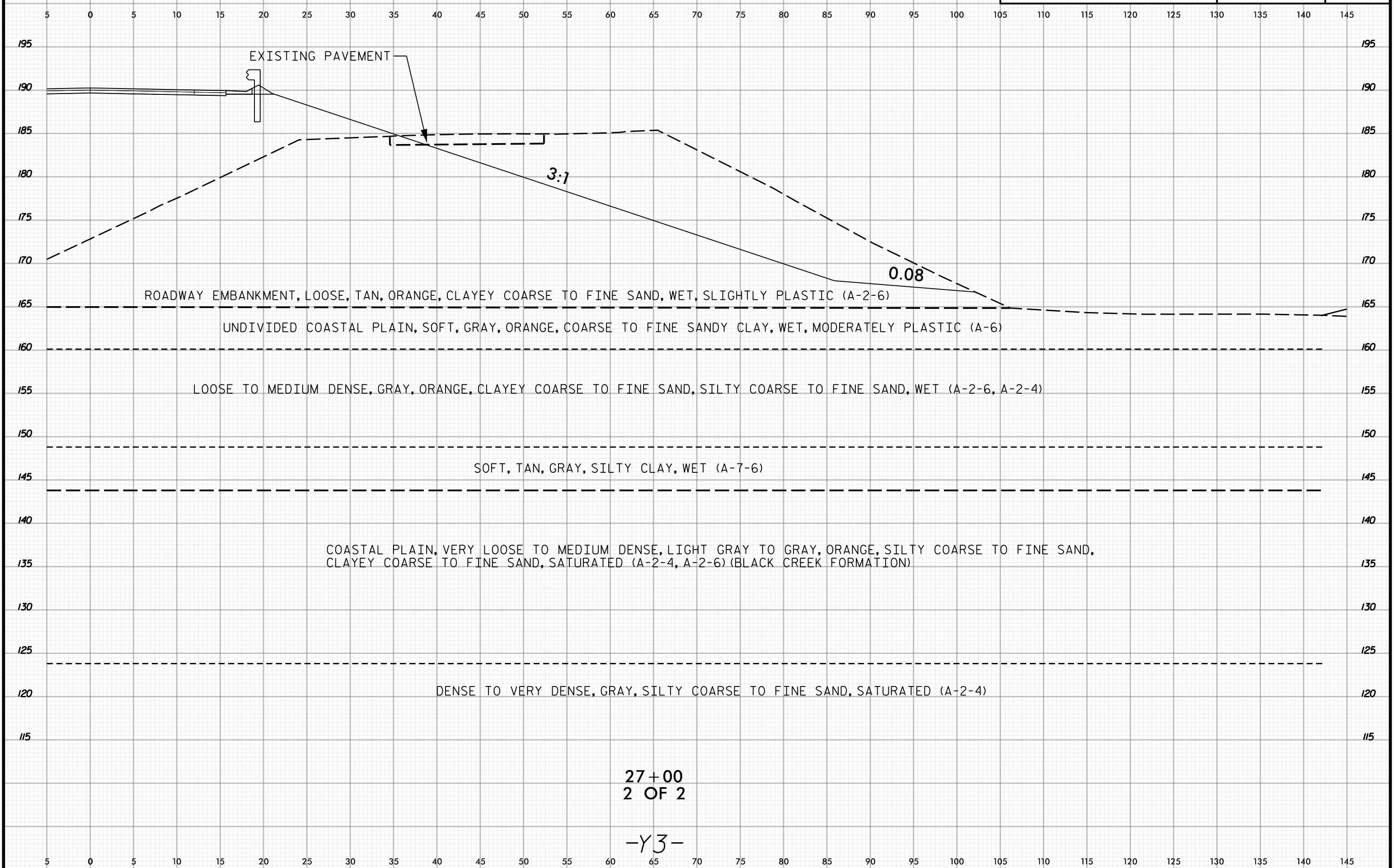

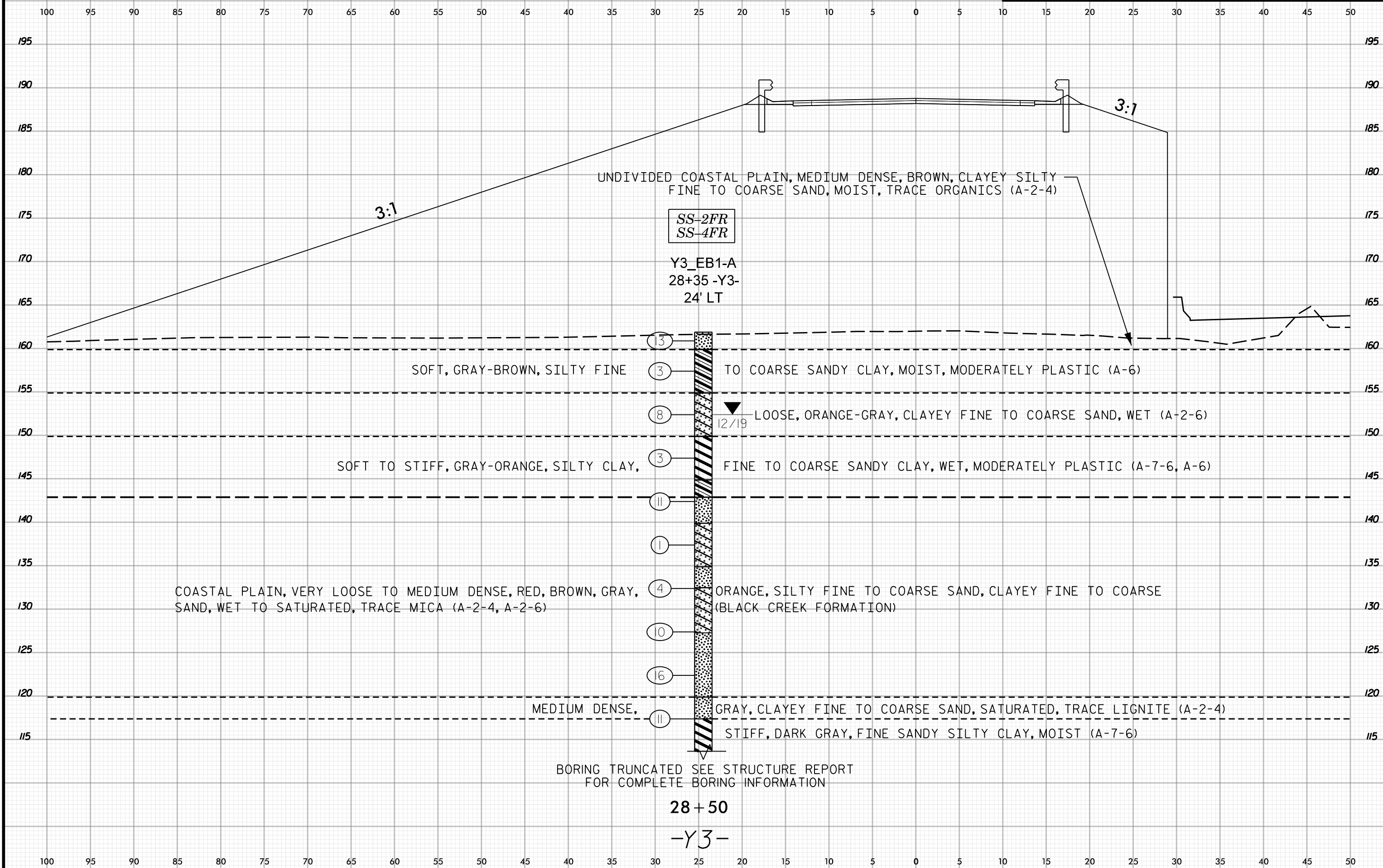
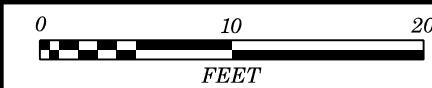

UNDIVIDED COASTAL PLAIN, MEDIUM DENSE, BROWN, CLAYEY SILTY FINE TO COARSE SAND, MOIST, TRACE ORGANICS (A-2-4)

SS-2FR  
SS-4FR

Y3\_EB1-A  
28+35 -Y3-  
24' LT

3:1

3:1

13

SOFT, GRAY-BROWN, SILTY FINE

3

TO COARSE SANDY CLAY, MOIST, MODERATELY PLASTIC (A-6)

8

12/19 LOOSE, ORANGE-GRAY, CLAYEY FINE TO COARSE SAND, WET (A-2-6)

3

SOFT TO STIFF, GRAY-ORANGE, SILTY CLAY,

FINE TO COARSE SANDY CLAY, WET, MODERATELY PLASTIC (A-7-6, A-6)

11

1

4

COASTAL PLAIN, VERY LOOSE TO MEDIUM DENSE, RED, BROWN, GRAY, SAND, WET TO SATURATED, TRACE MICA (A-2-4, A-2-6)

ORANGE, SILTY FINE TO COARSE SAND, CLAYEY FINE TO COARSE (BLACK CREEK FORMATION)

10

16

11

MEDIUM DENSE,

GRAY, CLAYEY FINE TO COARSE SAND, SATURATED, TRACE LIGNITE (A-2-4)

STIFF, DARK GRAY, FINE SANDY SILTY CLAY, MOIST (A-7-6)

BORING TRUNCATED SEE STRUCTURE REPORT FOR COMPLETE BORING INFORMATION

28+50

-Y3-

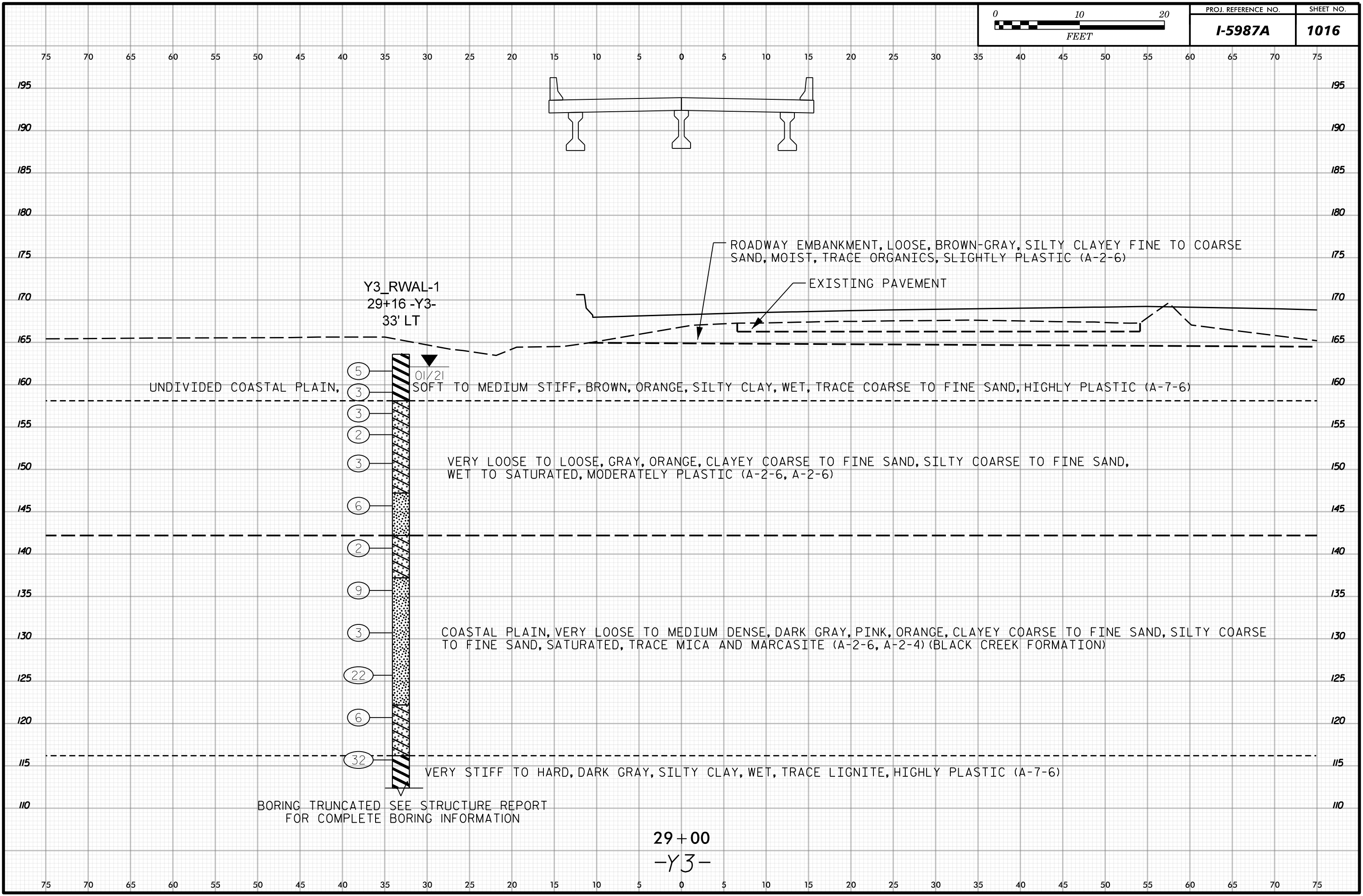

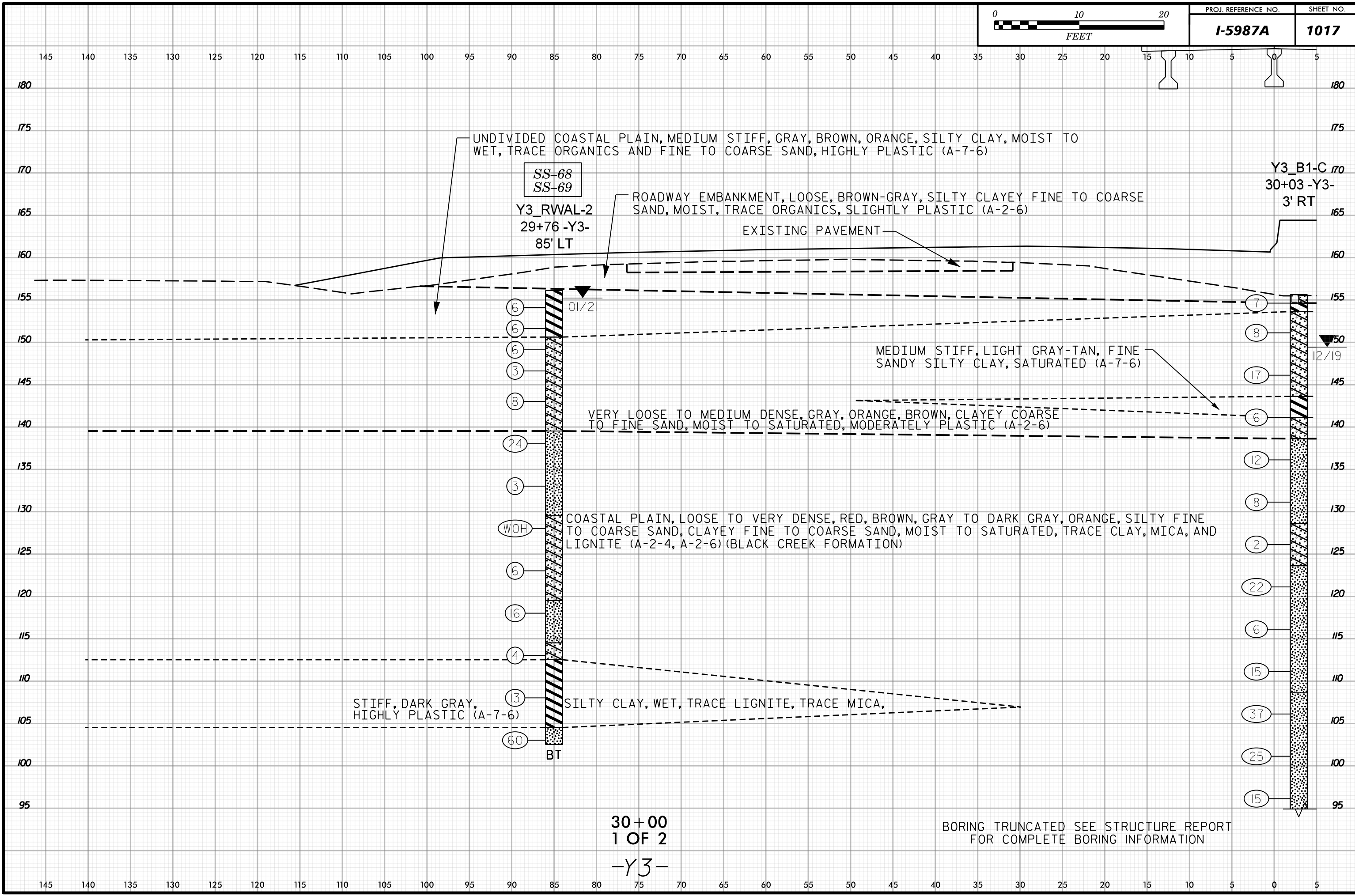
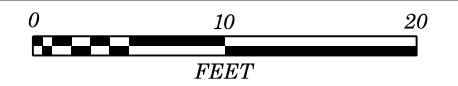

30+00  
1 OF 2  
-Y3-

BORING TRUNCATED SEE STRUCTURE REPORT  
FOR COMPLETE BORING INFORMATION

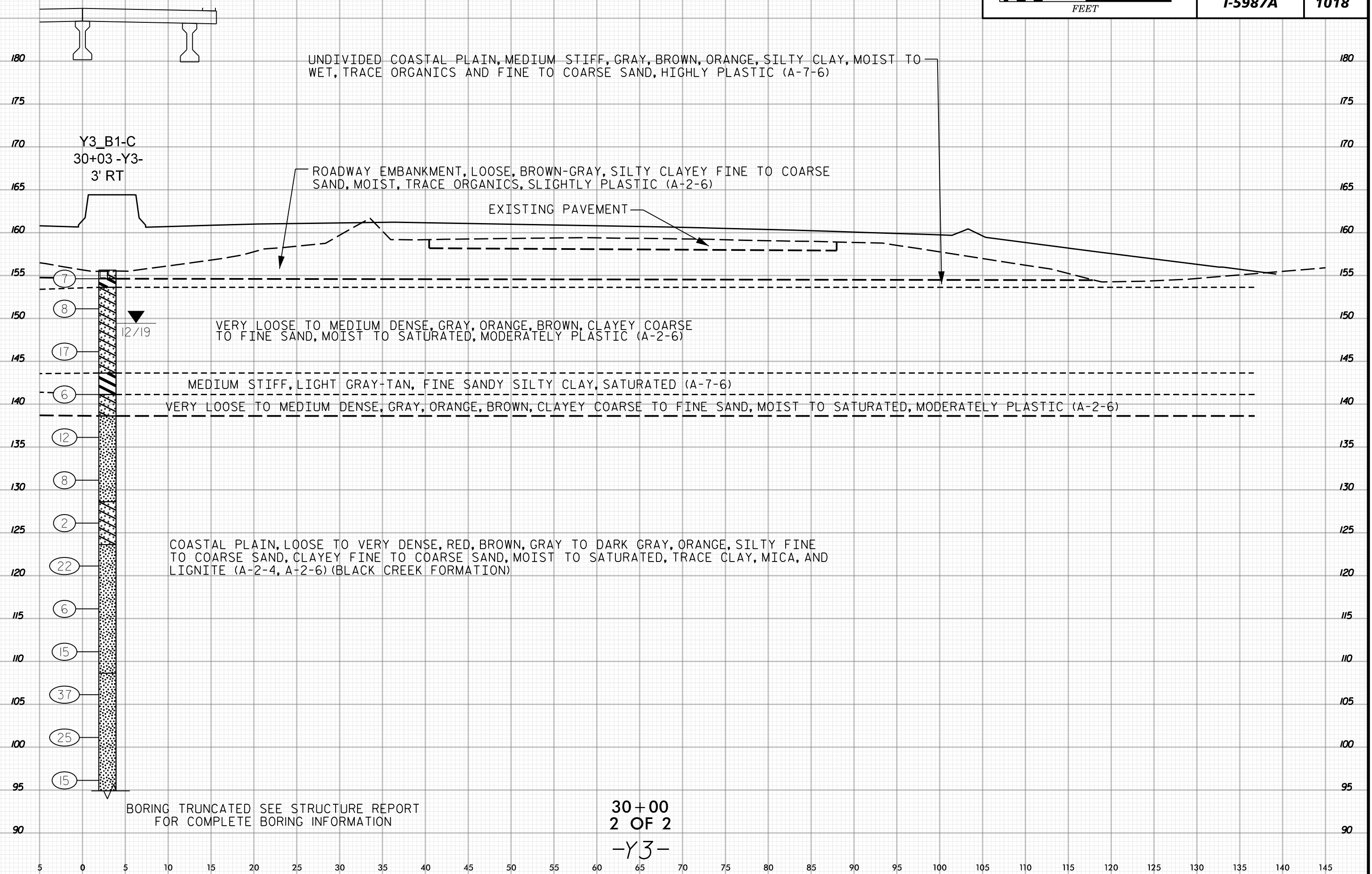

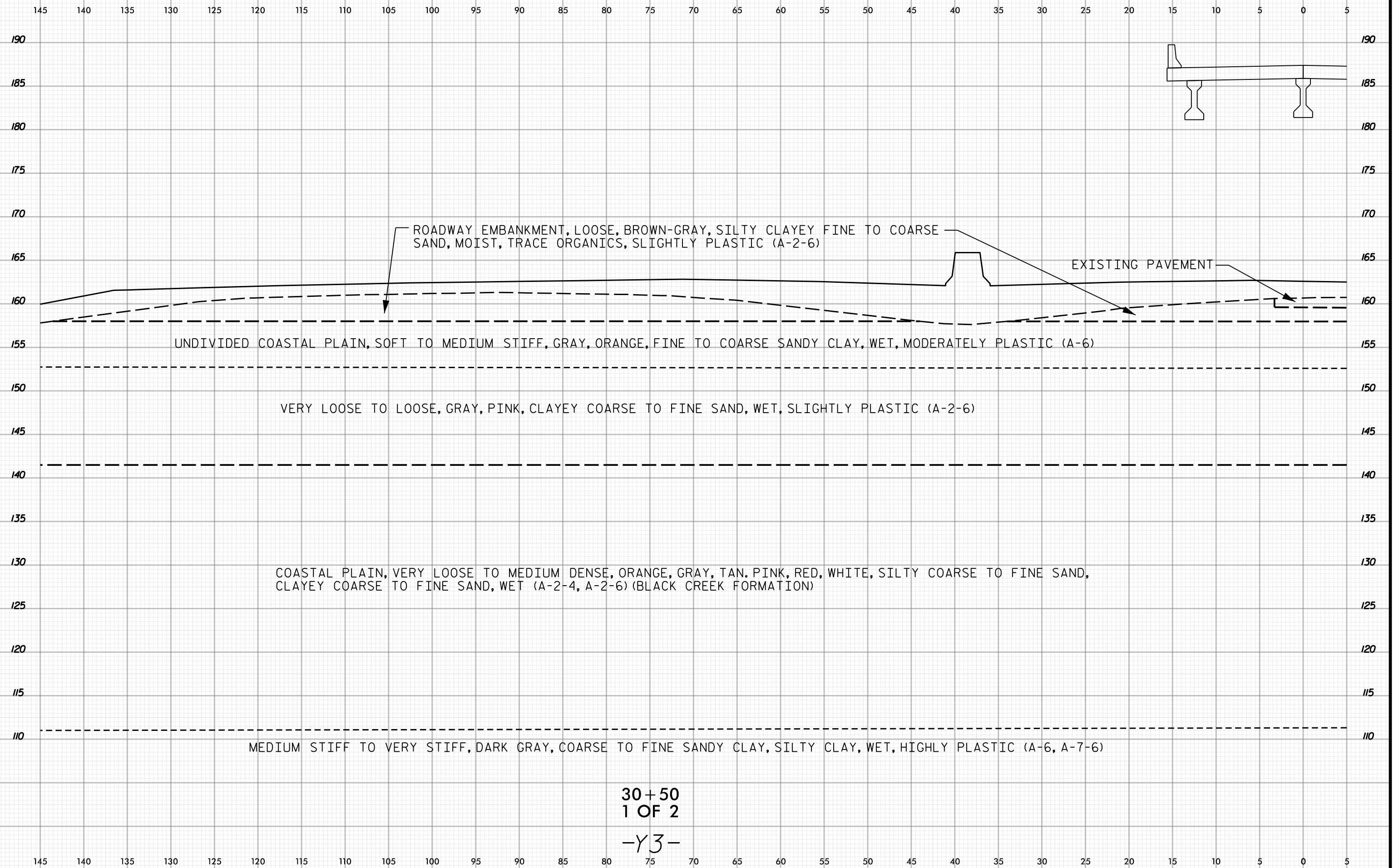

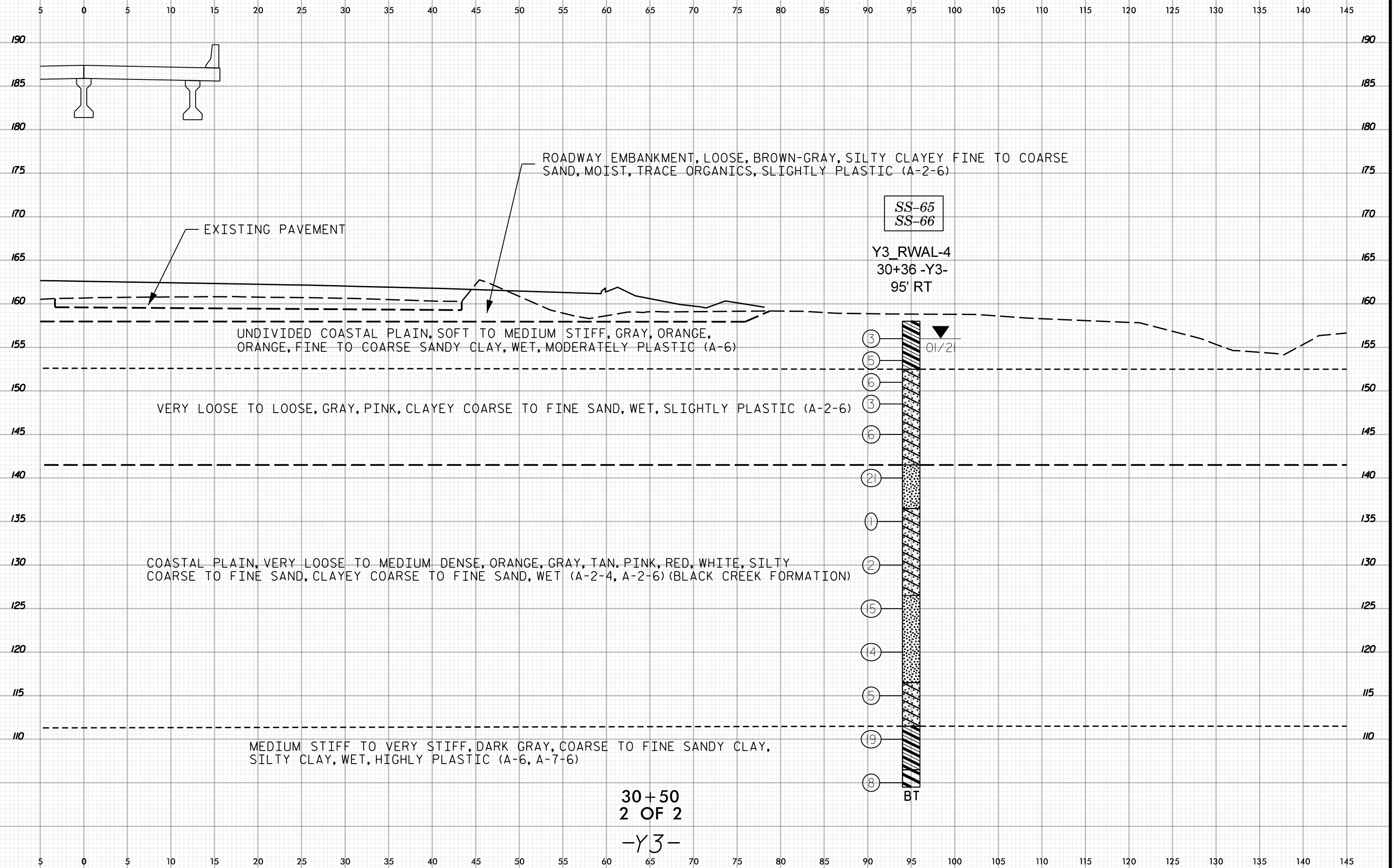
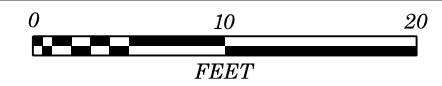

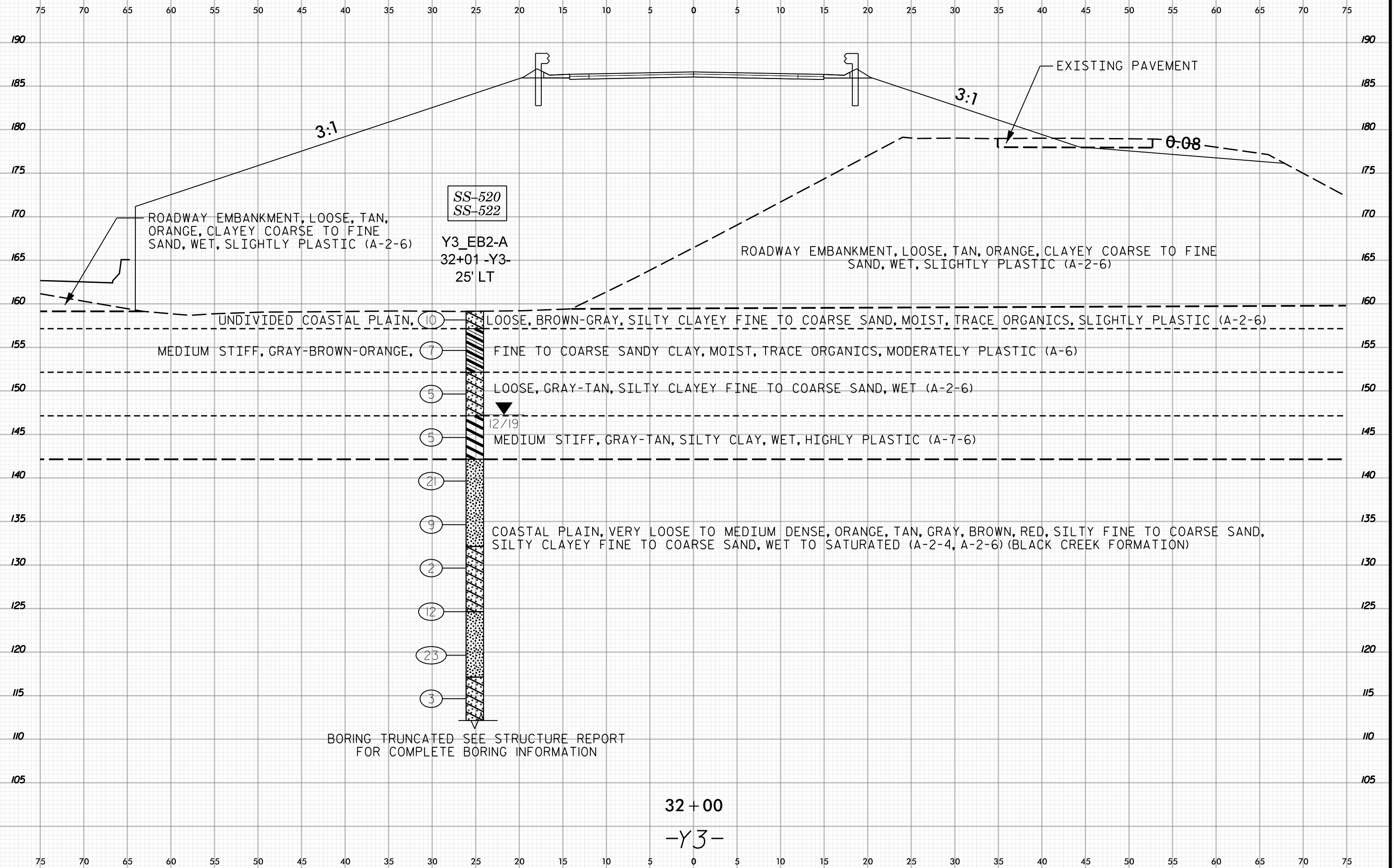
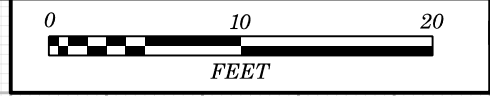

32 + 00  
-Y3-



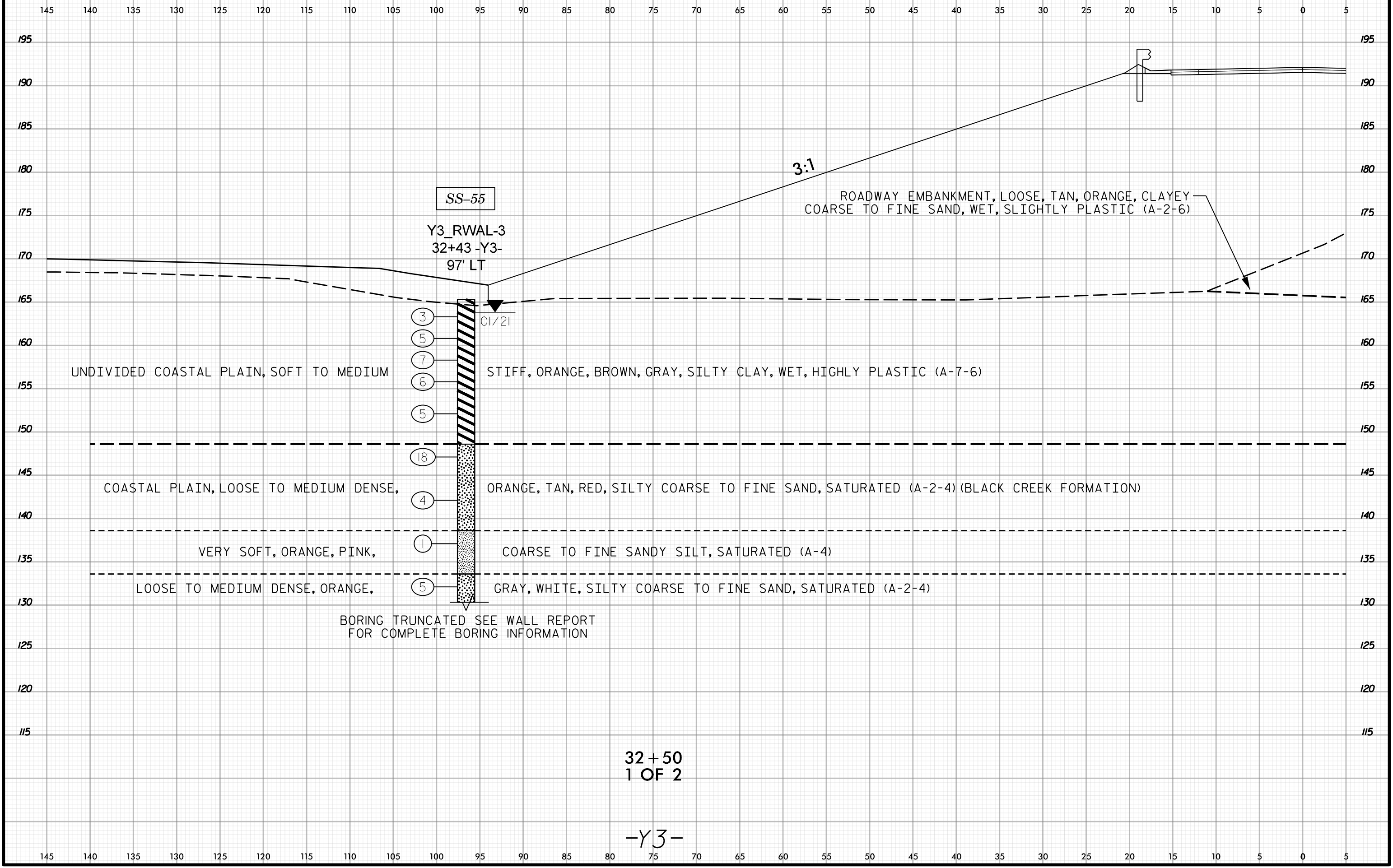
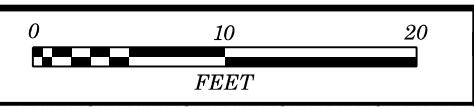

32+50  
1 OF 2

-Y3-

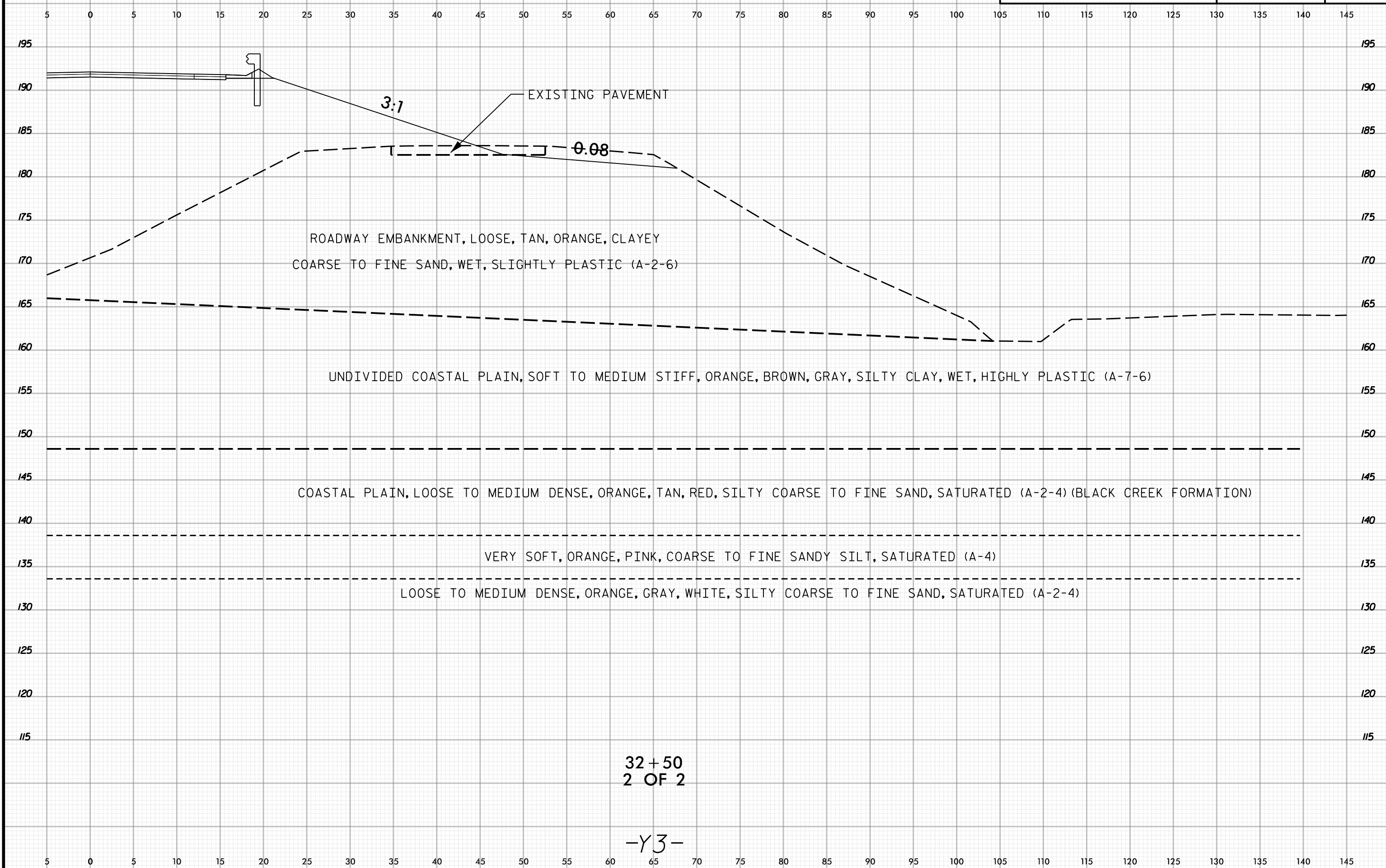

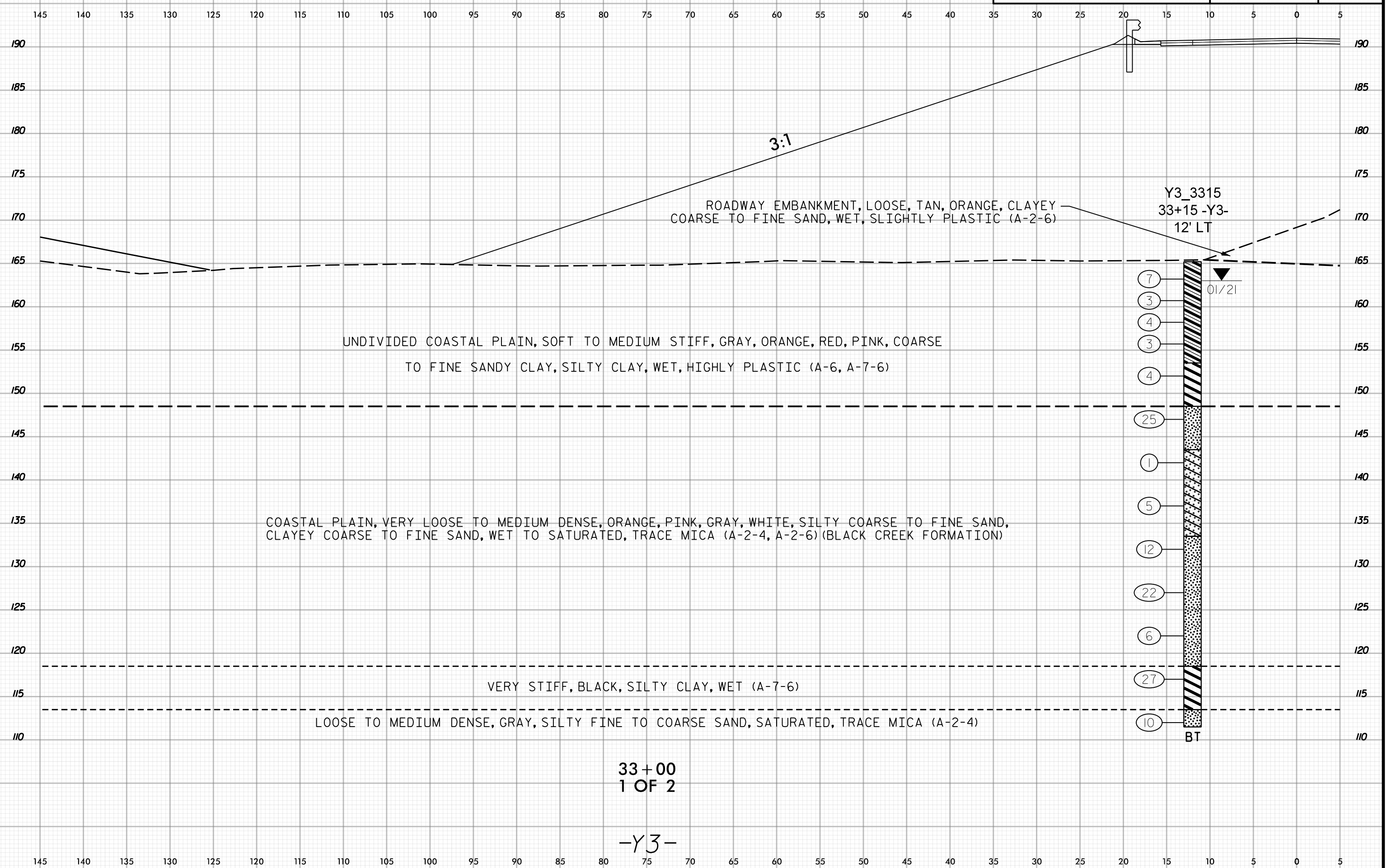
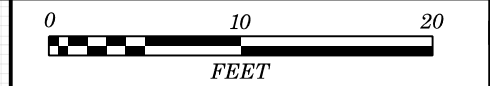

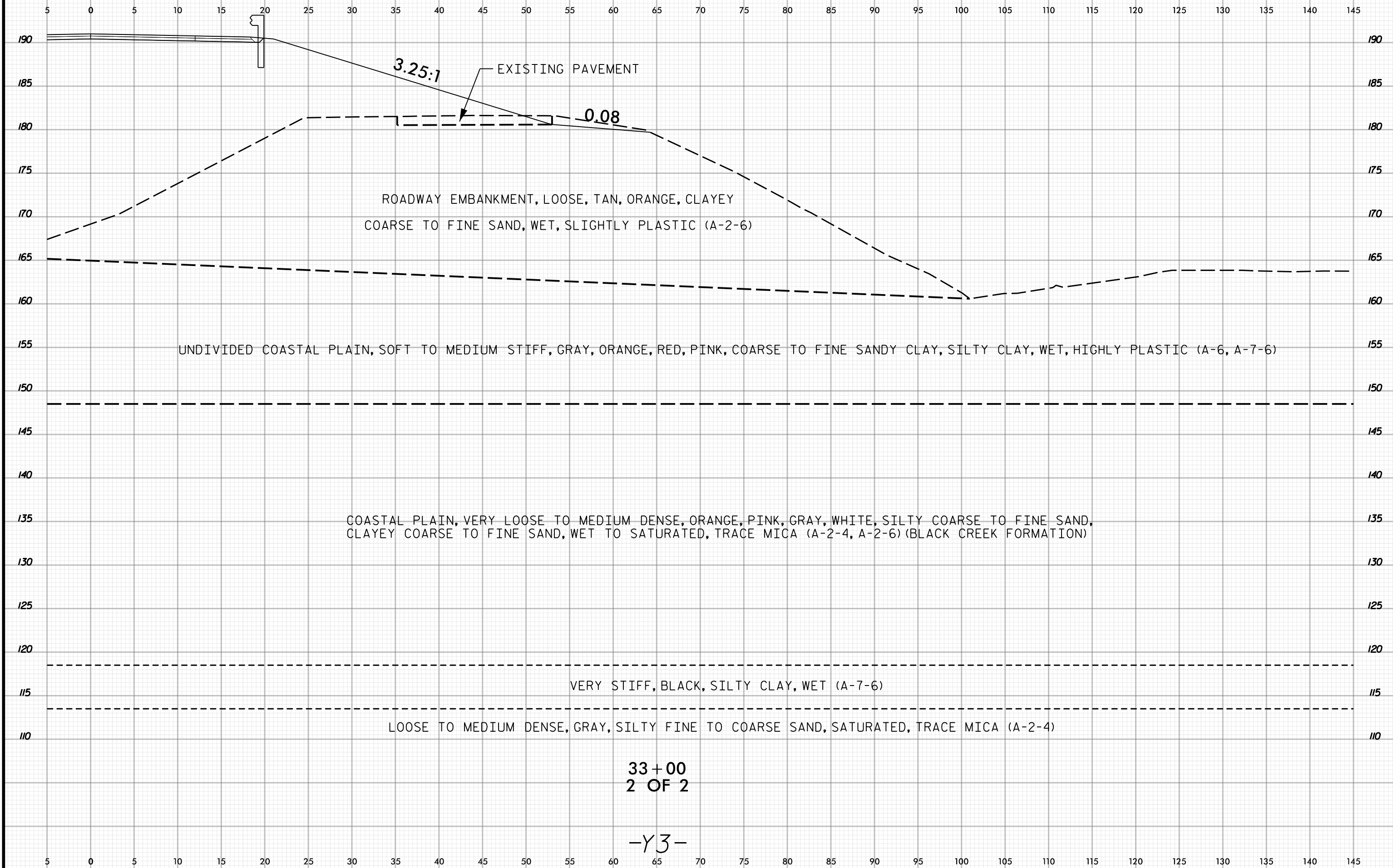
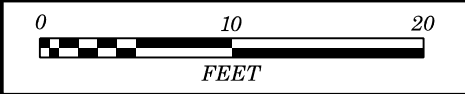

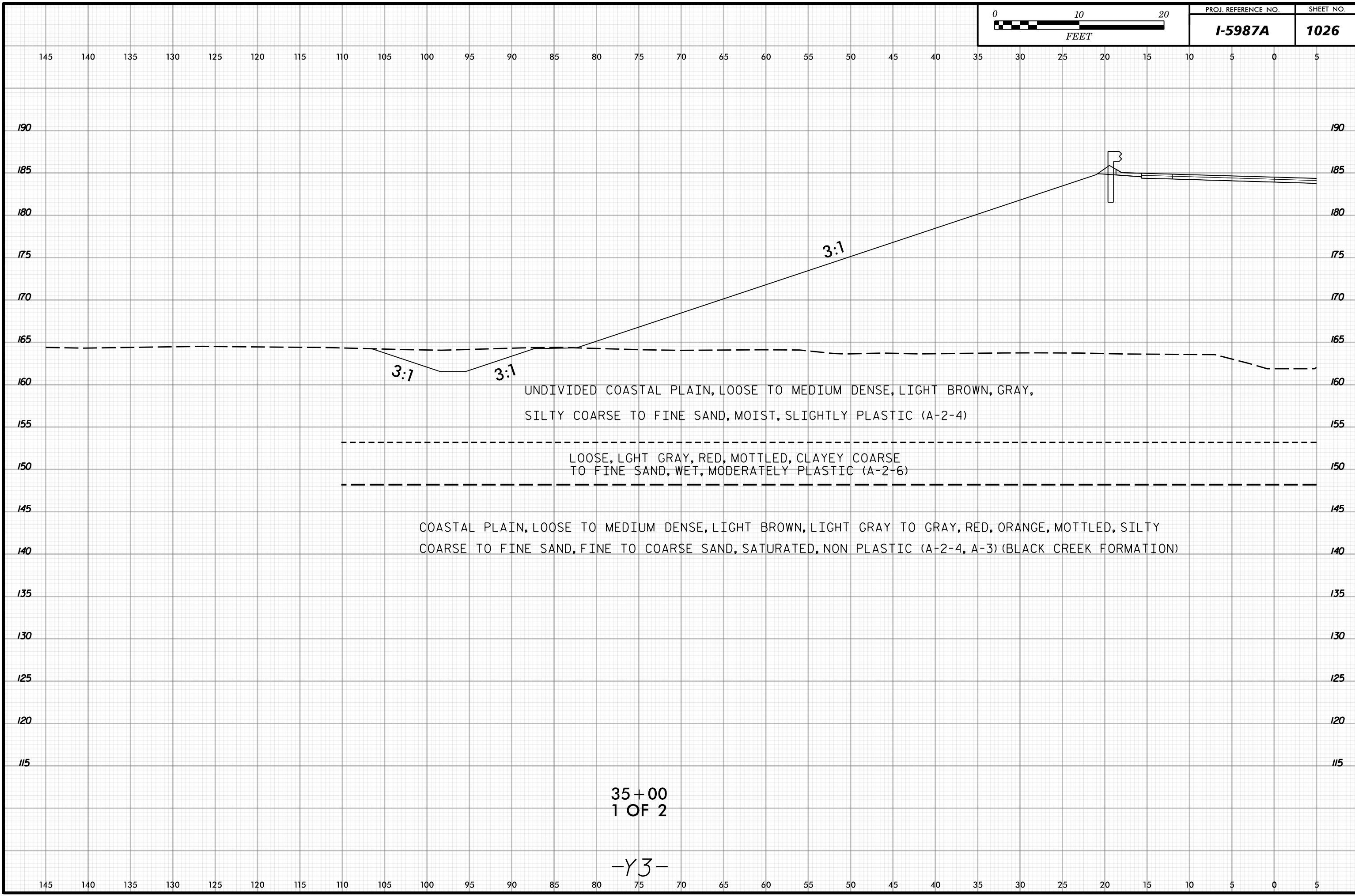
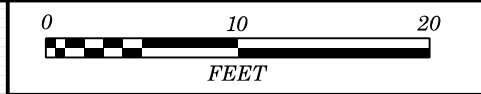

UNDIVIDED COASTAL PLAIN, LOOSE TO MEDIUM DENSE, LIGHT BROWN, GRAY,  
SILTY COARSE TO FINE SAND, MOIST, SLIGHTLY PLASTIC (A-2-4)

LOOSE, LGHT GRAY, RED, MOTTLED, CLAYEY COARSE  
TO FINE SAND, WET, MODERATELY PLASTIC (A-2-6)

COASTAL PLAIN, LOOSE TO MEDIUM DENSE, LIGHT BROWN, LIGHT GRAY TO GRAY, RED, ORANGE, MOTTLED, SILTY  
COARSE TO FINE SAND, FINE TO COARSE SAND, SATURATED, NON PLASTIC (A-2-4, A-3) (BLACK CREEK FORMATION)

35+00  
1 OF 2

-Y3-

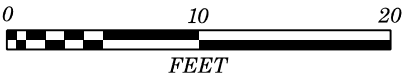

5 0 5 10 15 20 25 30 35 40 45 50 55 60 65 70 75 80 85 90 95 100 105 110 115 120 125 130 135 140 145

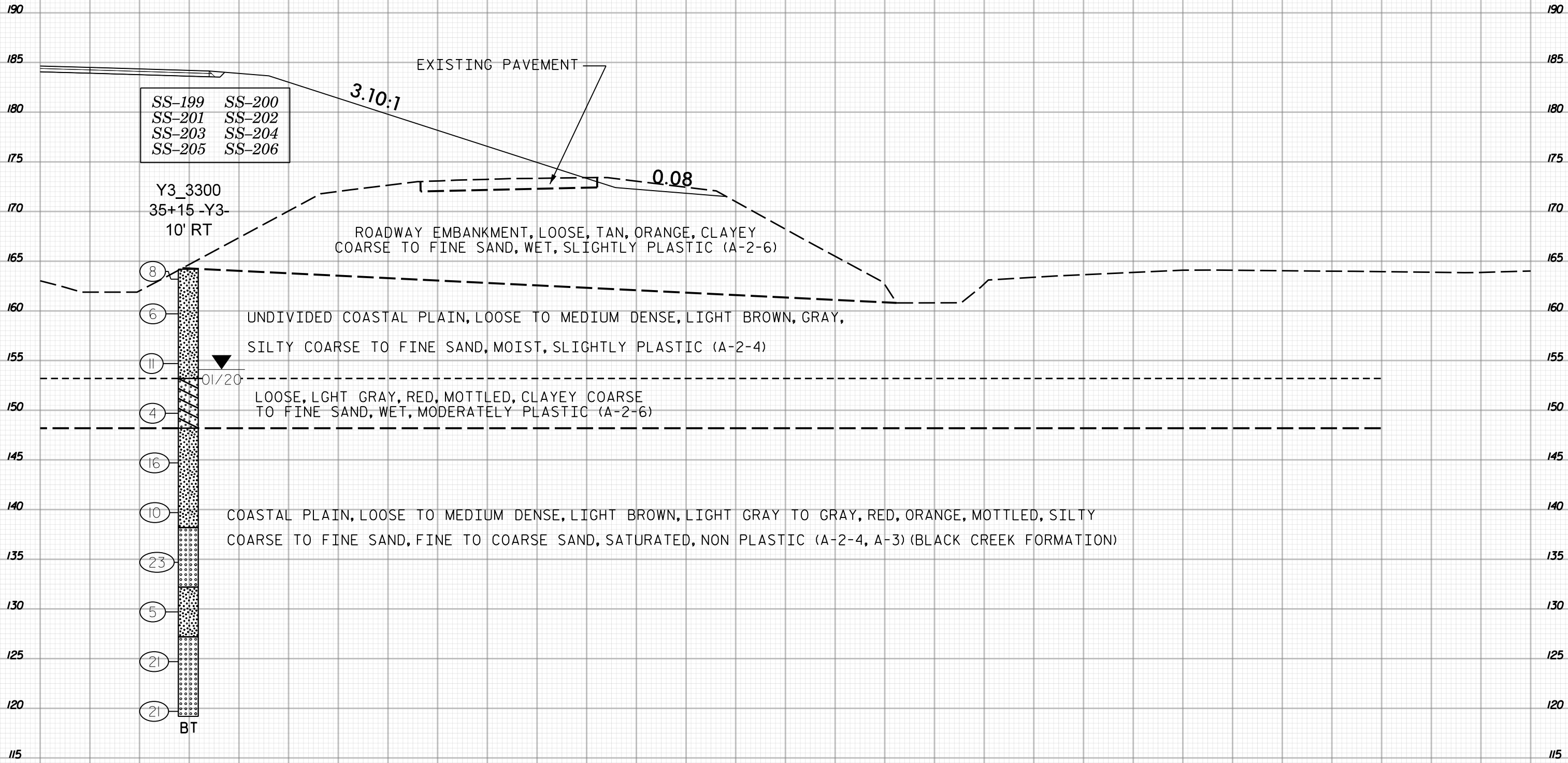

SS-199	SS-200
SS-201	SS-202
SS-203	SS-204
SS-205	SS-206

Y3\_3300  
35+15 -Y3-  
10' RT

35+00  
2 OF 2

-Y3-

5 0 5 10 15 20 25 30 35 40 45 50 55 60 65 70 75 80 85 90 95 100 105 110 115 120 125 130 135 140 145

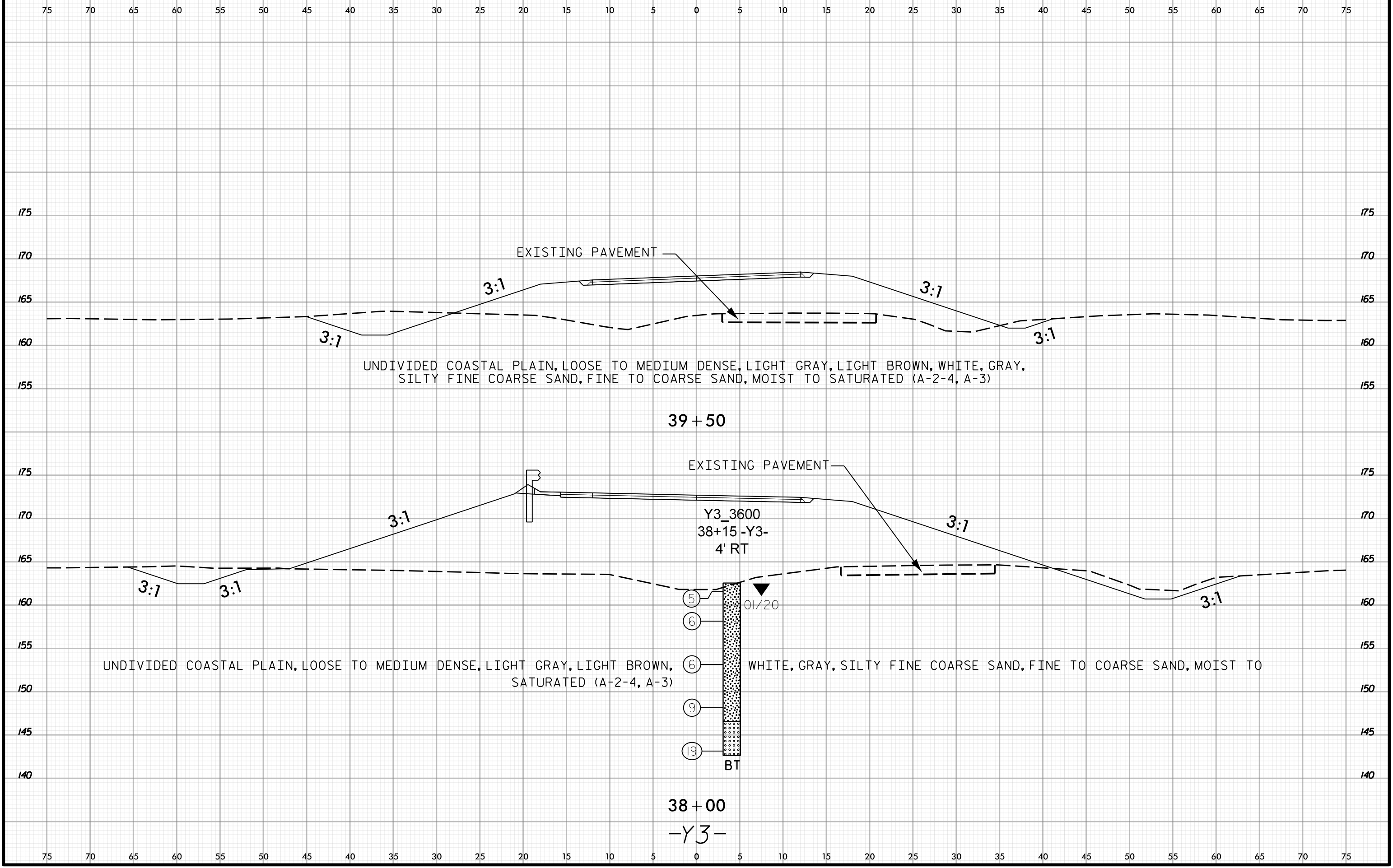
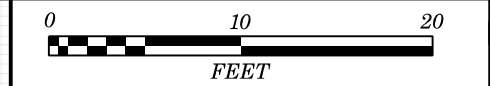

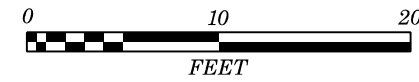

75 70 65 60 55 50 45 40 35 30 25 20 15 10 5 0 5 10 15 20 25 30 35 40 45 50 55 60 65 70 75

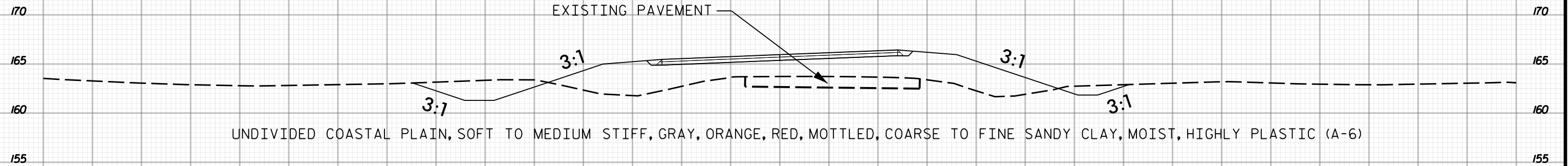

40+50

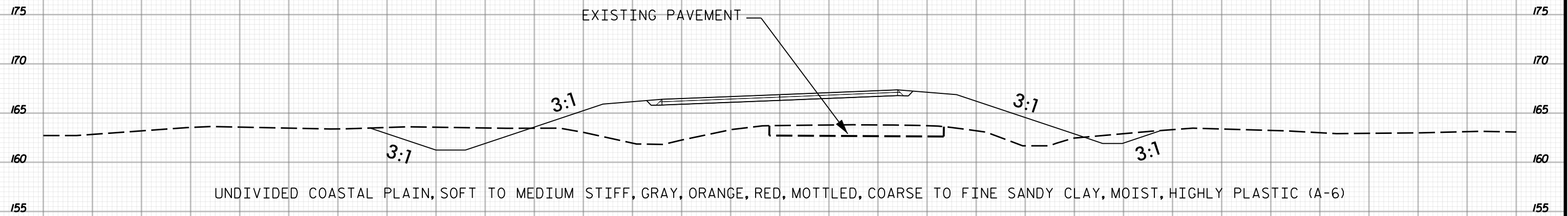

40+00

-Y3-

75 70 65 60 55 50 45 40 35 30 25 20 15 10 5 0 5 10 15 20 25 30 35 40 45 50 55 60 65 70 75



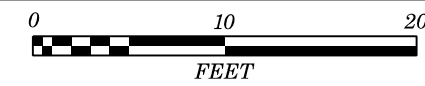

75 70 65 60 55 50 45 40 35 30 25 20 15 10 5 0 5 10 15 20 25 30 35 40 45 50 55 60 65 70 75

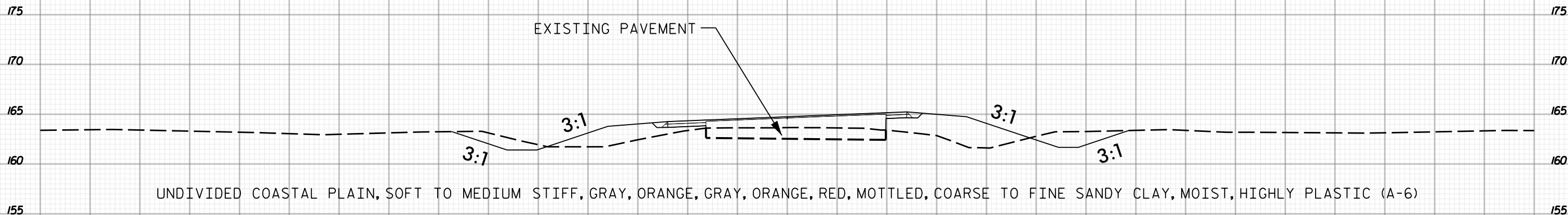

41+50

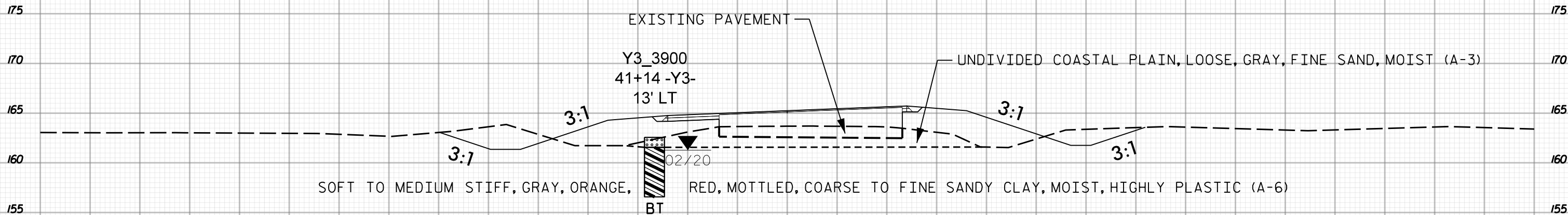

41+00  
-Y3-

75 70 65 60 55 50 45 40 35 30 25 20 15 10 5 0 5 10 15 20 25 30 35 40 45 50 55 60 65 70 75

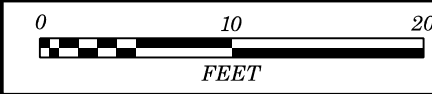

75 70 65 60 55 50 45 40 35 30 25 20 15 10 5 0 5 10 15 20 25 30 35 40 45 50 55 60 65 70 75

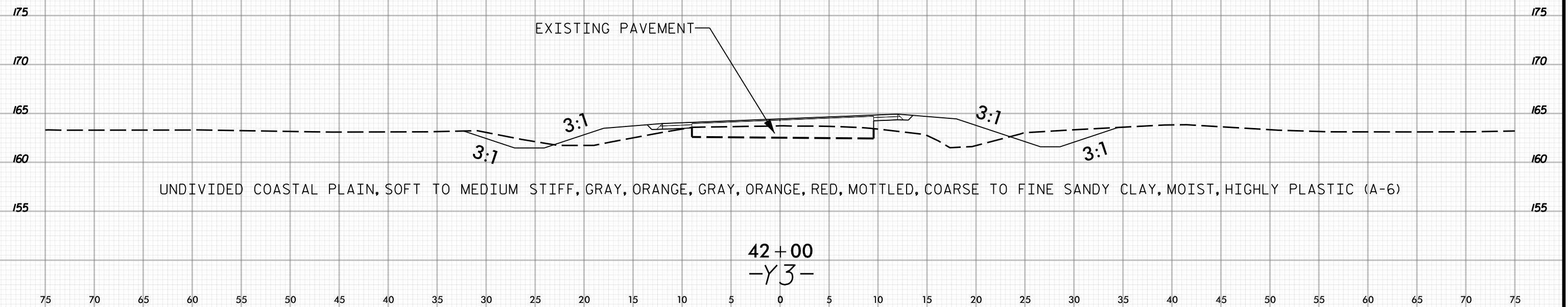
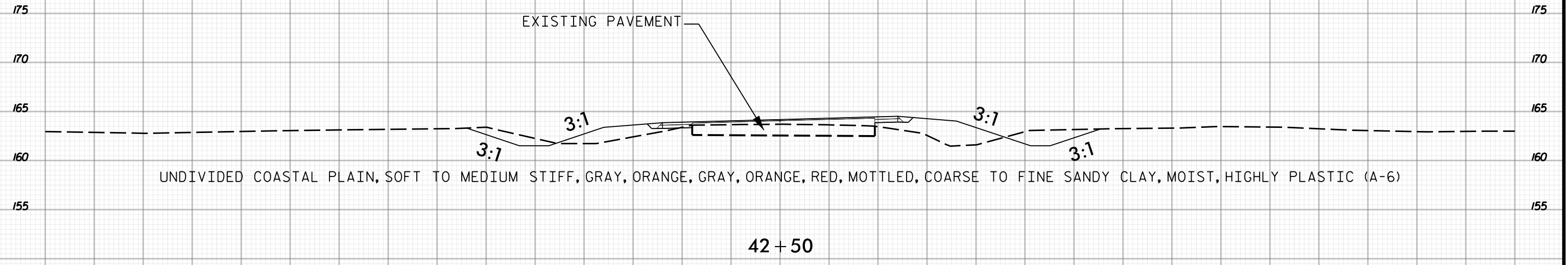

75 70 65 60 55 50 45 40 35 30 25 20 15 10 5 0 5 10 15 20 25 30 35 40 45 50 55 60 65 70 75

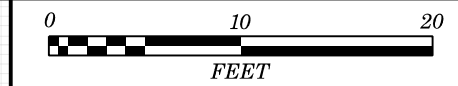

75 70 65 60 55 50 45 40 35 30 25 20 15 10 5 0 5 10 15 20 25 30 35 40 45 50 55 60 65 70 75

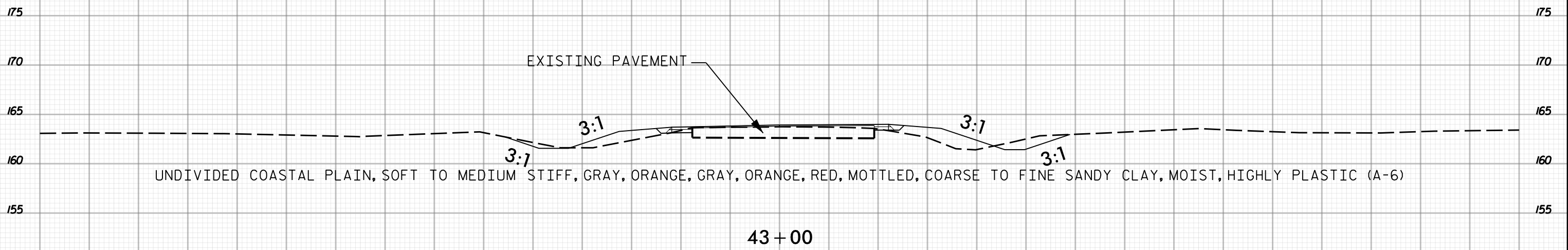
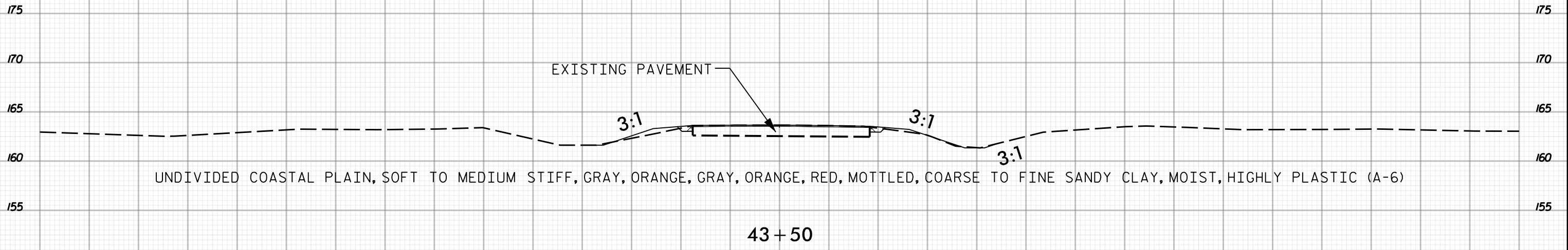

-Y3-

75 70 65 60 55 50 45 40 35 30 25 20 15 10 5 0 5 10 15 20 25 30 35 40 45 50 55 60 65 70 75

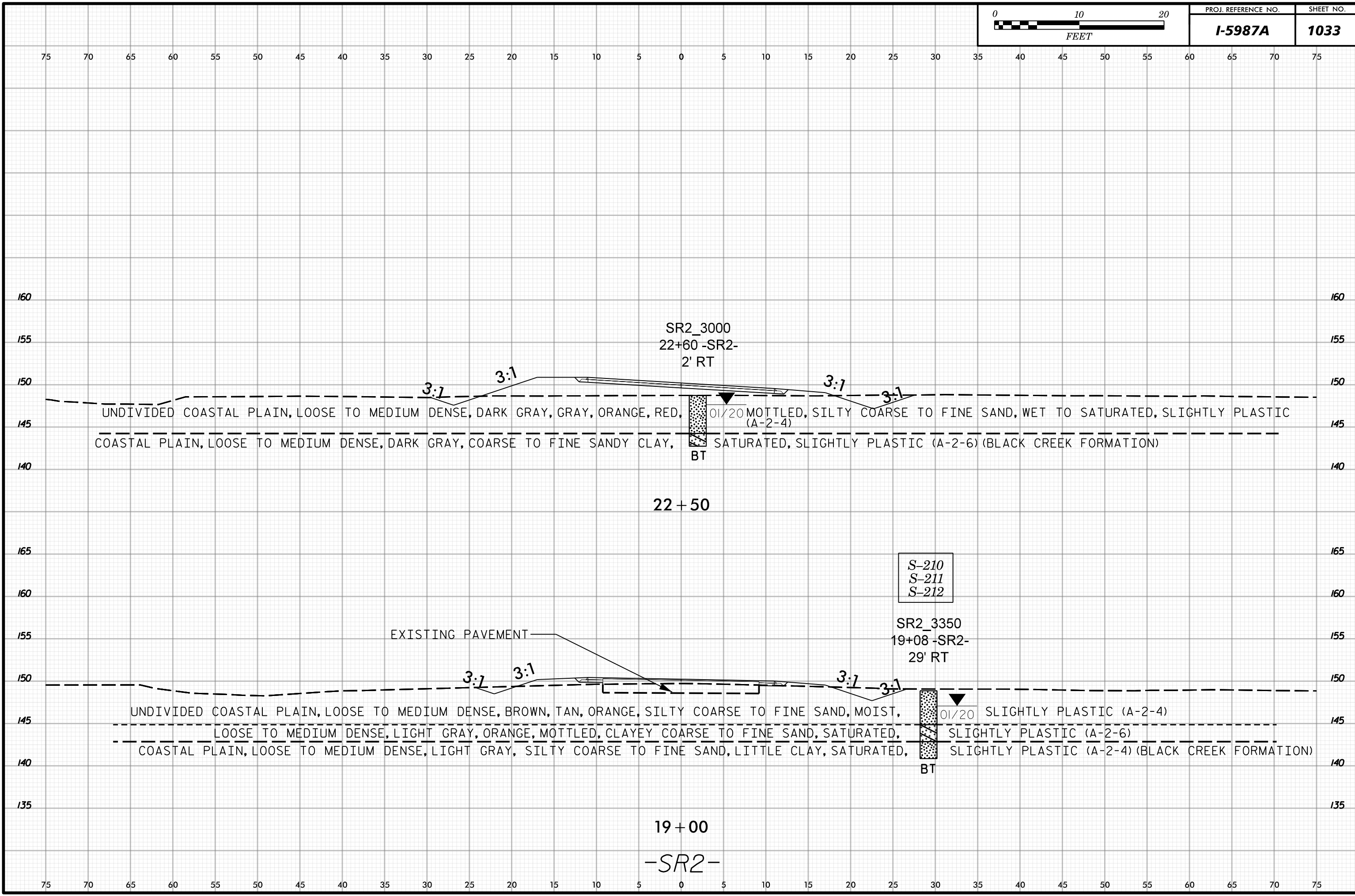
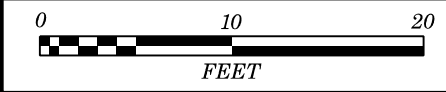

SR2\_3000  
22+60 -SR2-  
2' RT

UNDIVIDED COASTAL PLAIN, LOOSE TO MEDIUM DENSE, DARK GRAY, GRAY, ORANGE, RED, 01/20 MOTTLED, SILTY COARSE TO FINE SAND, WET TO SATURATED, SLIGHTLY PLASTIC (A-2-4)  
COASTAL PLAIN, LOOSE TO MEDIUM DENSE, DARK GRAY, COARSE TO FINE SANDY CLAY, SATURATED, SLIGHTLY PLASTIC (A-2-6) (BLACK CREEK FORMATION)

22 + 50

S-210  
S-211  
S-212

SR2\_3350  
19+08 -SR2-  
29' RT

EXISTING PAVEMENT

UNDIVIDED COASTAL PLAIN, LOOSE TO MEDIUM DENSE, BROWN, TAN, ORANGE, SILTY COARSE TO FINE SAND, MOIST, 01/20 SLIGHTLY PLASTIC (A-2-4)  
LOOSE TO MEDIUM DENSE, LIGHT GRAY, ORANGE, MOTTLED, CLAYEY COARSE TO FINE SAND, SATURATED, SLIGHTLY PLASTIC (A-2-6)  
COASTAL PLAIN, LOOSE TO MEDIUM DENSE, LIGHT GRAY, SILTY COARSE TO FINE SAND, LITTLE CLAY, SATURATED, SLIGHTLY PLASTIC (A-2-4) (BLACK CREEK FORMATION)

19 + 00  
-SR2-

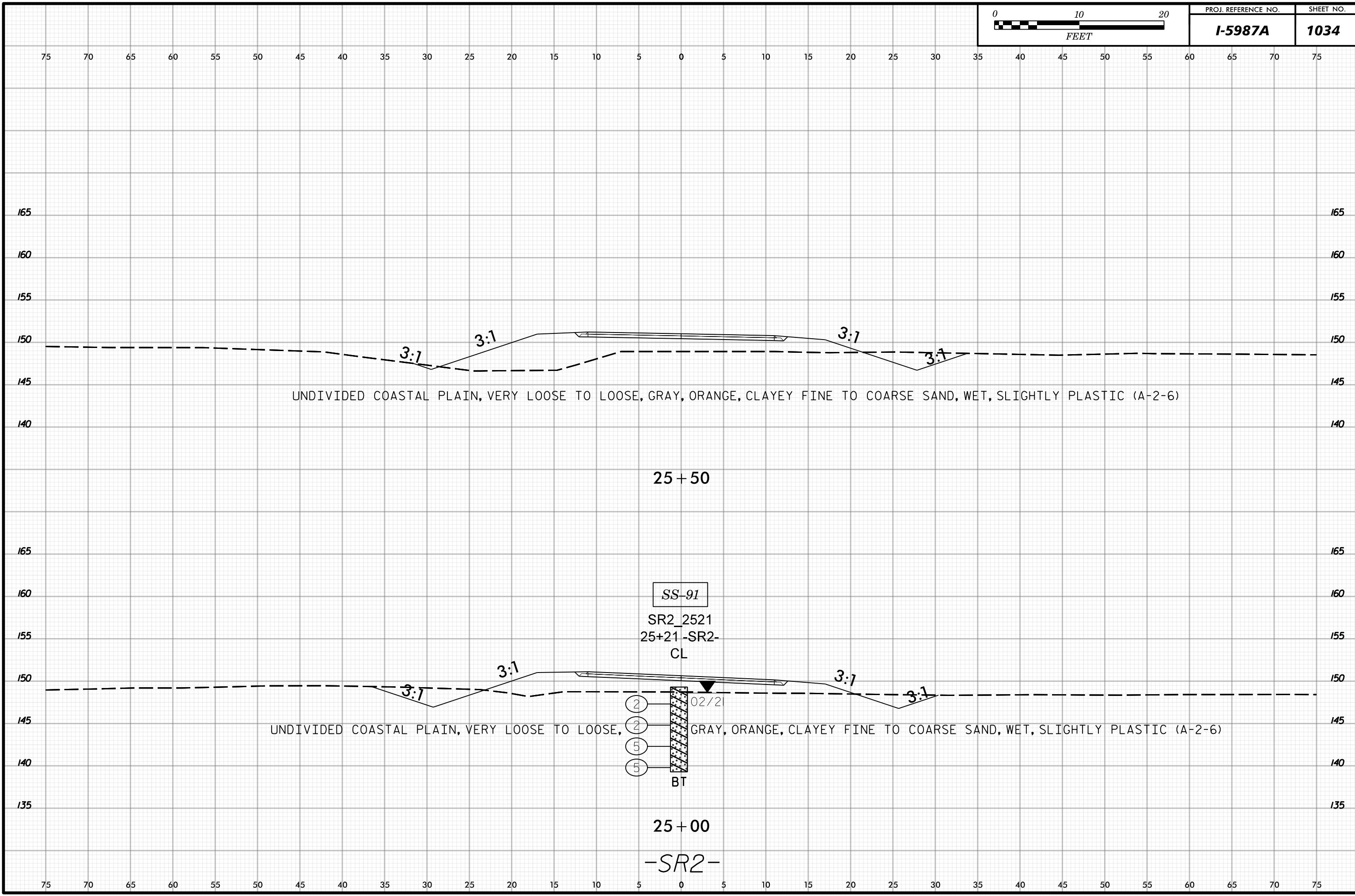
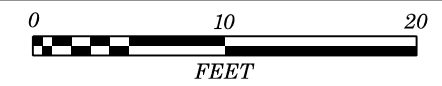

75 70 65 60 55 50 45 40 35 30 25 20 15 10 5 0 5 10 15 20 25 30 35 40 45 50 55 60 65 70 75

165  
160  
155  
150  
145  
140

UNDIVIDED COASTAL PLAIN, VERY LOOSE TO LOOSE, GRAY, ORANGE, CLAYEY FINE TO COARSE SAND, WET, SLIGHTLY PLASTIC (A-2-6)

25 + 50

165  
160  
155  
150  
145  
140

UNDIVIDED COASTAL PLAIN, VERY LOOSE TO LOOSE, GRAY, ORANGE, CLAYEY FINE TO COARSE SAND, WET, SLIGHTLY PLASTIC (A-2-6)

SS-91

SR2\_2521  
25+21-SR2-  
CL

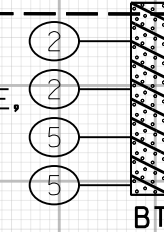

02/21

25 + 00

-SR2-

75 70 65 60 55 50 45 40 35 30 25 20 15 10 5 0 5 10 15 20 25 30 35 40 45 50 55 60 65 70 75

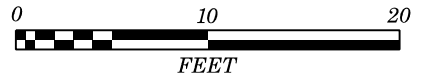

75 70 65 60 55 50 45 40 35 30 25 20 15 10 5 0 5 10 15 20 25 30 35 40 45 50 55 60 65 70 75

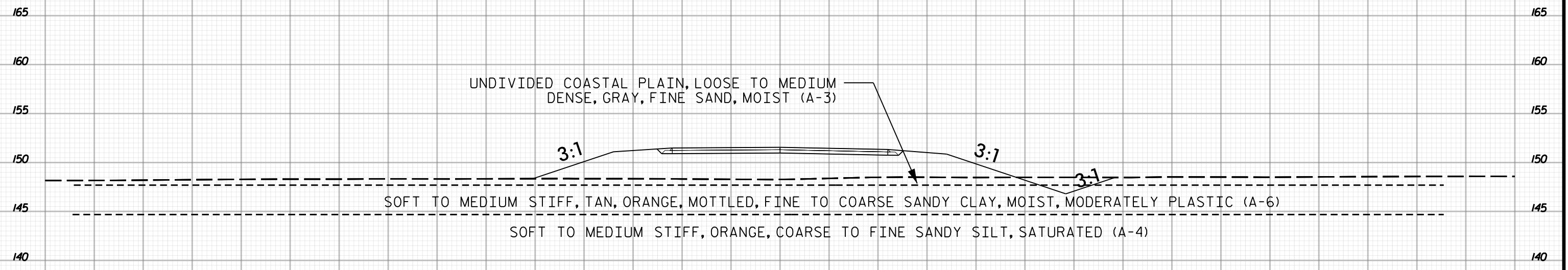
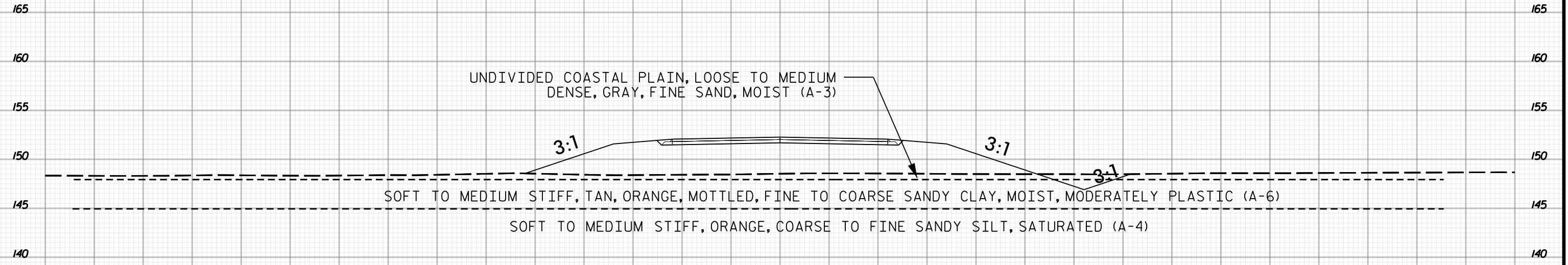

26+00  
-SR2-

75 70 65 60 55 50 45 40 35 30 25 20 15 10 5 0 5 10 15 20 25 30 35 40 45 50 55 60 65 70 75

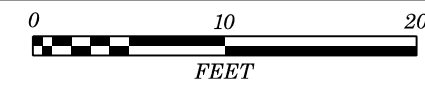

75 70 65 60 55 50 45 40 35 30 25 20 15 10 5 0 5 10 15 20 25 30 35 40 45 50 55 60 65 70 75

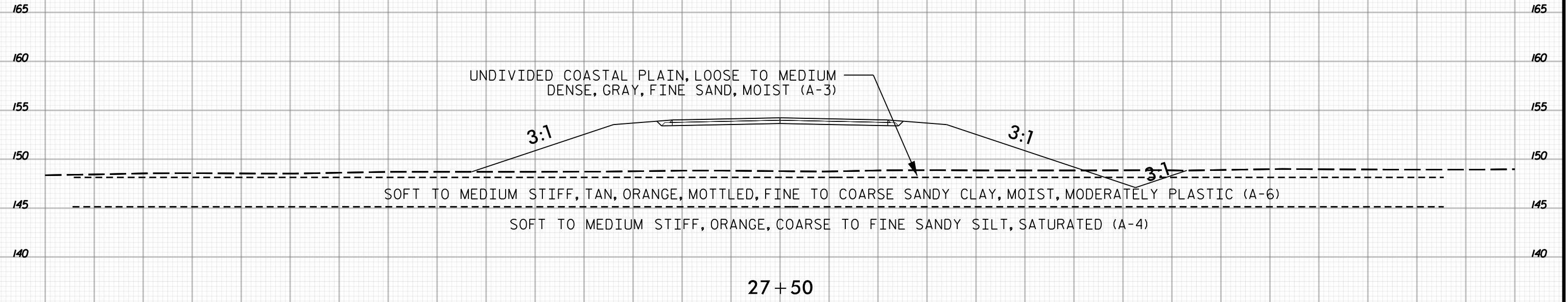

**27+50**

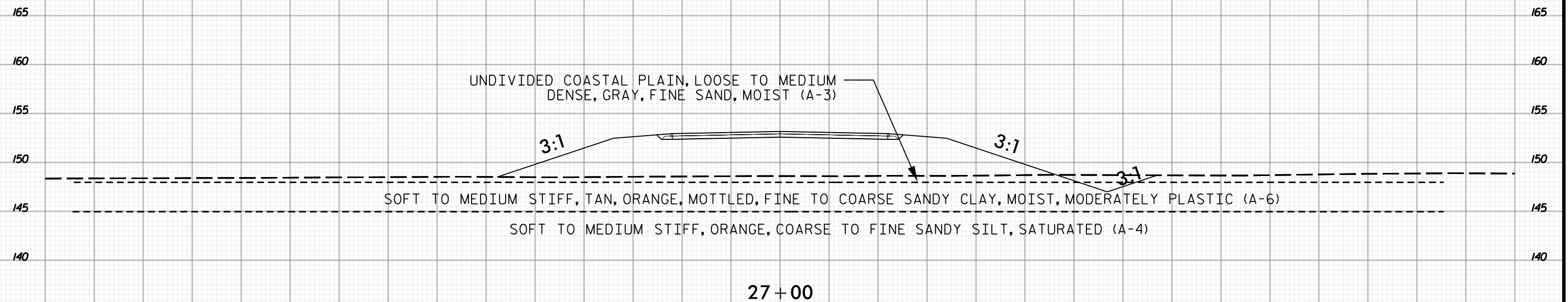

**27+00**

**-SR2-**

75 70 65 60 55 50 45 40 35 30 25 20 15 10 5 0 5 10 15 20 25 30 35 40 45 50 55 60 65 70 75



PROJ. REFERENCE NO.	SHEET NO.
I-5987A	1037

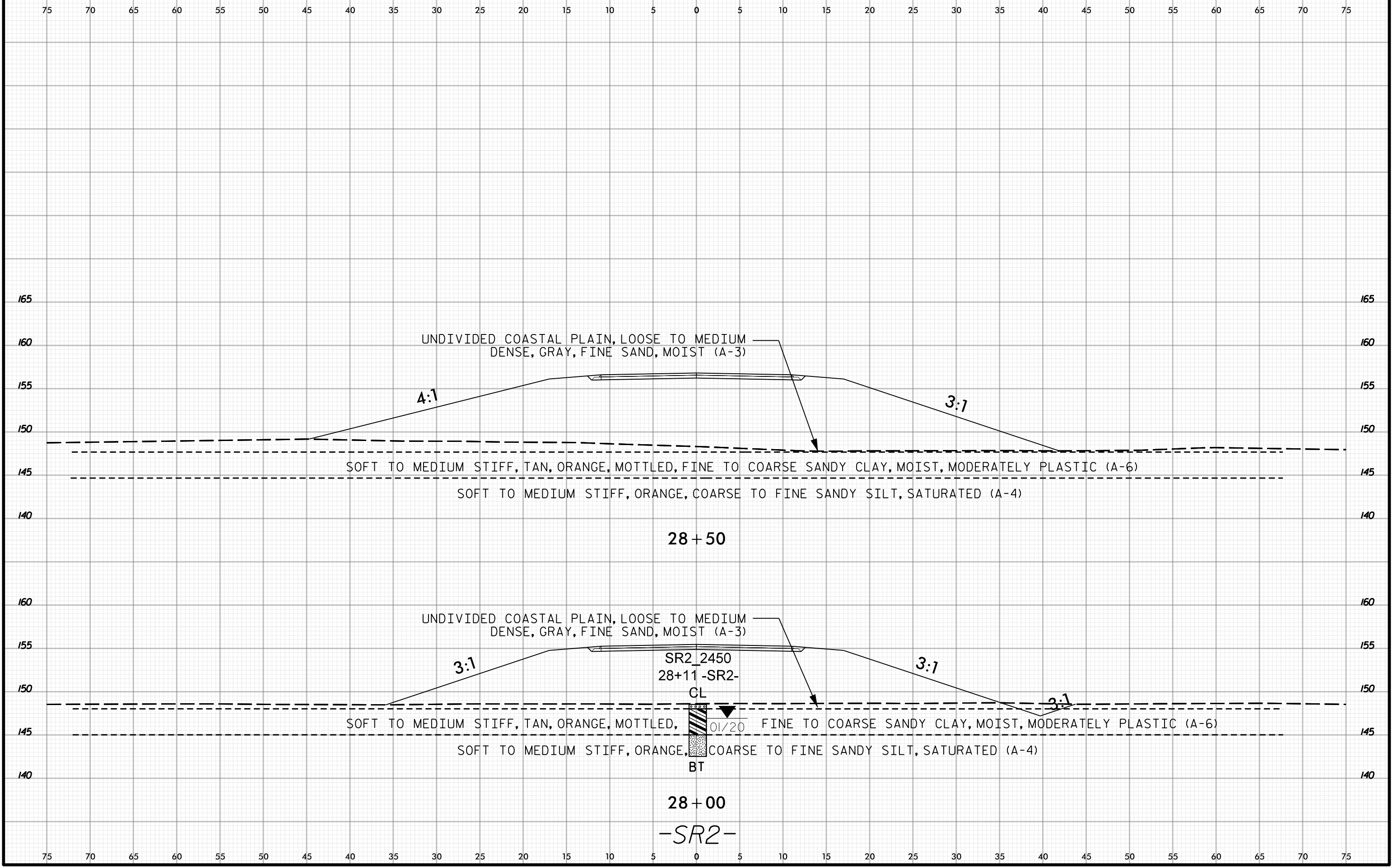



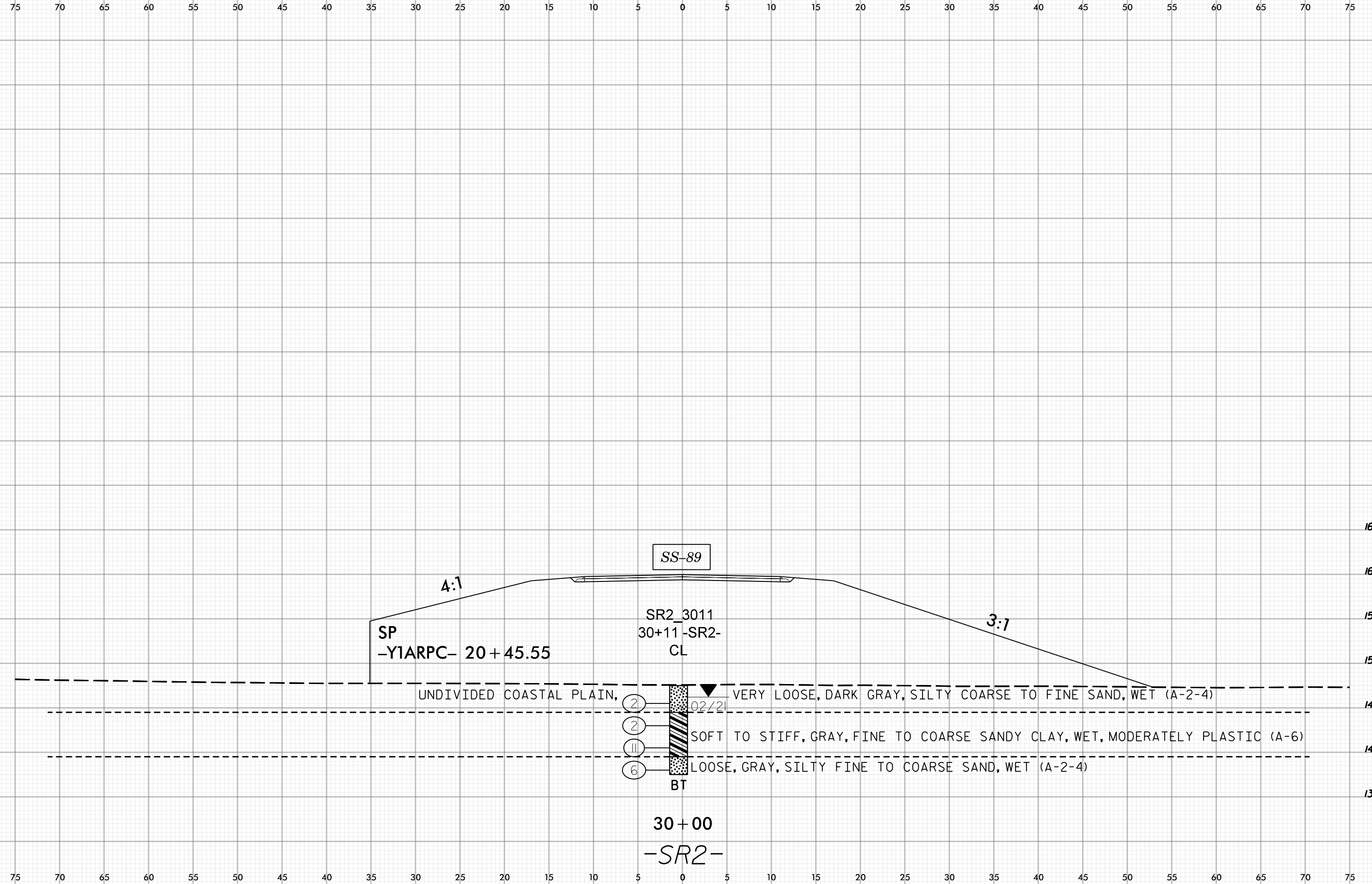
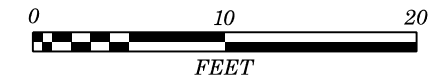

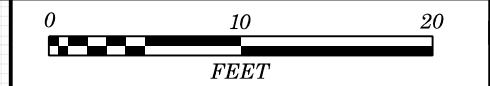

60 55 50 45 40 35 30 25 20 15 10 5 0 5 10 15 20 25 30 35 40 45 50 55 60 65 70 75 80 85 90

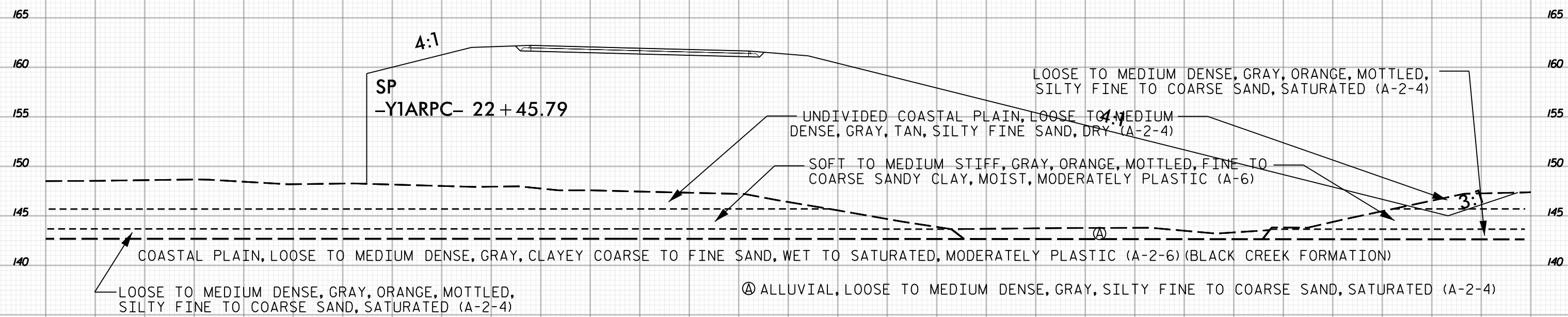

32 + 00

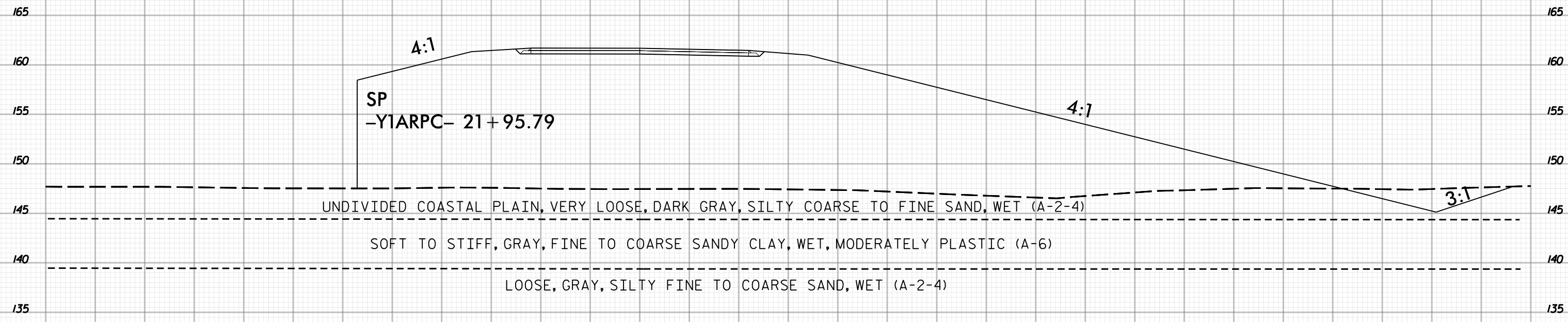

31 + 50

-SR2-

60 55 50 45 40 35 30 25 20 15 10 5 0 5 10 15 20 25 30 35 40 45 50 55 60 65 70 75 80 85 90

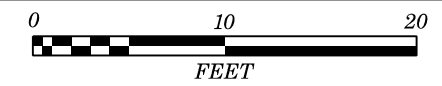

65 60 55 50 45 40 35 30 25 20 15 10 5 0 5 10 15 20 25 30 35 40 45 50 55 60 65 70 75 80 85

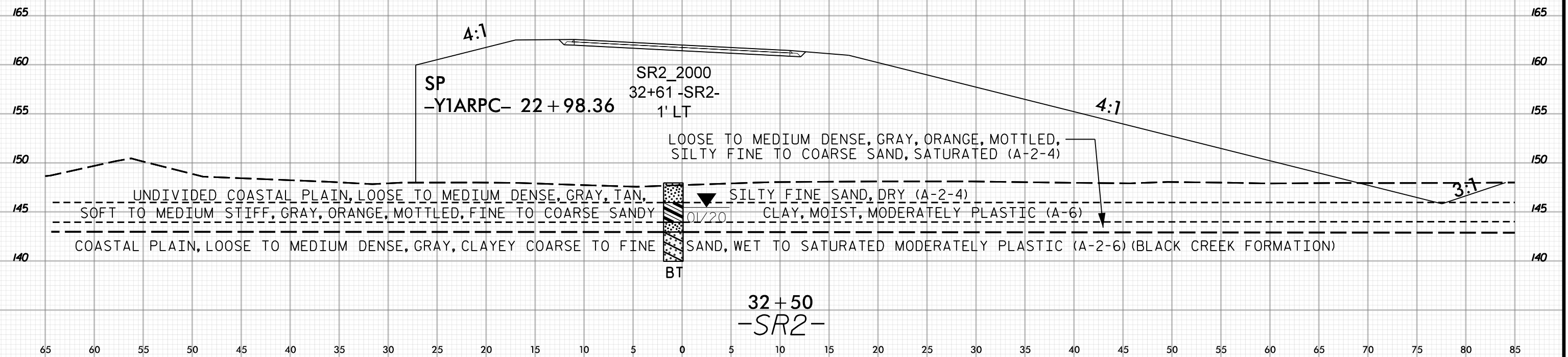

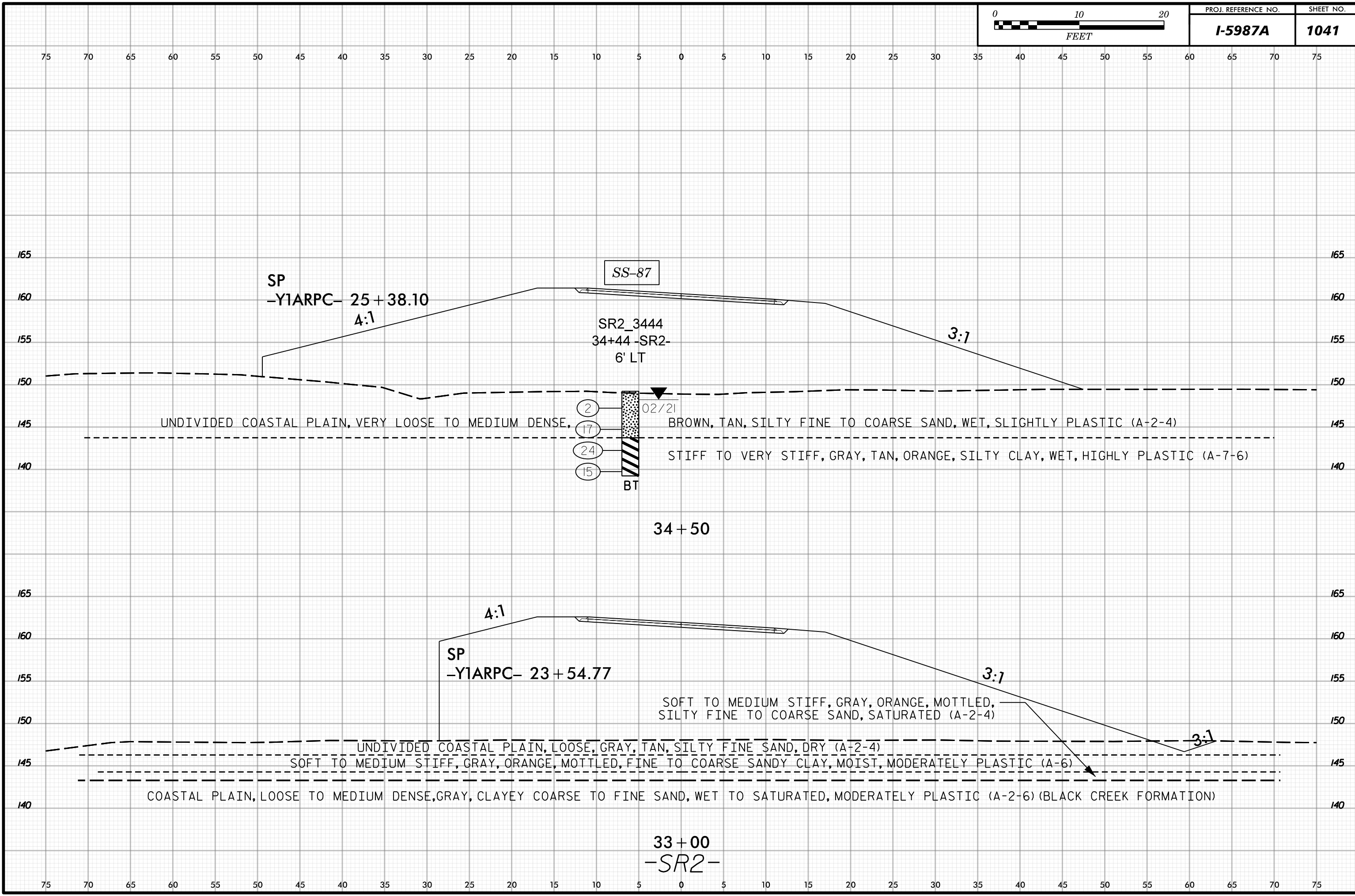
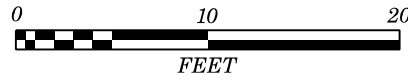

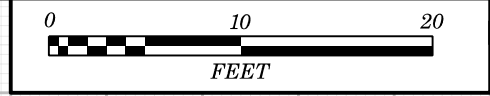

75 70 65 60 55 50 45 40 35 30 25 20 15 10 5 0 5 10 15 20 25 30 35 40 45 50 55 60 65 70 75

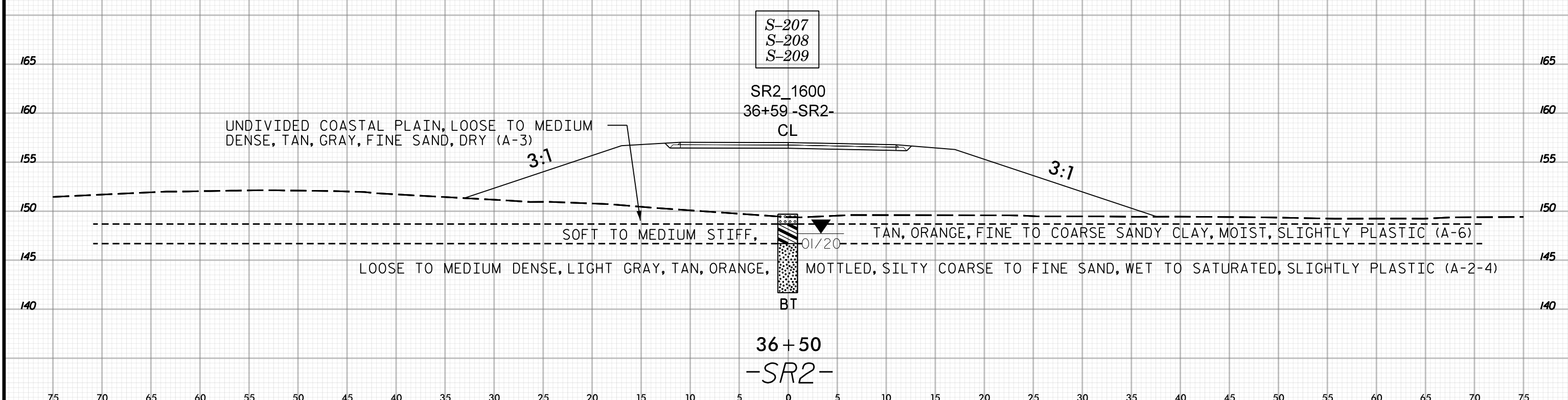
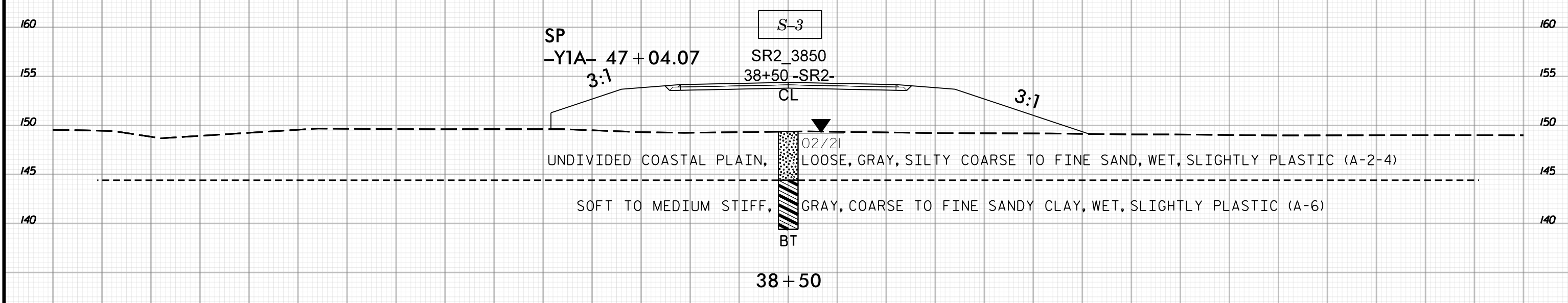

75 70 65 60 55 50 45 40 35 30 25 20 15 10 5 0 5 10 15 20 25 30 35 40 45 50 55 60 65 70 75

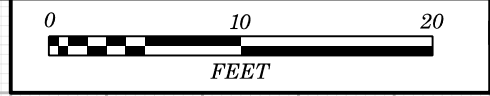

PROJ. REFERENCE NO.	SHEET NO.
I-5987A	1043

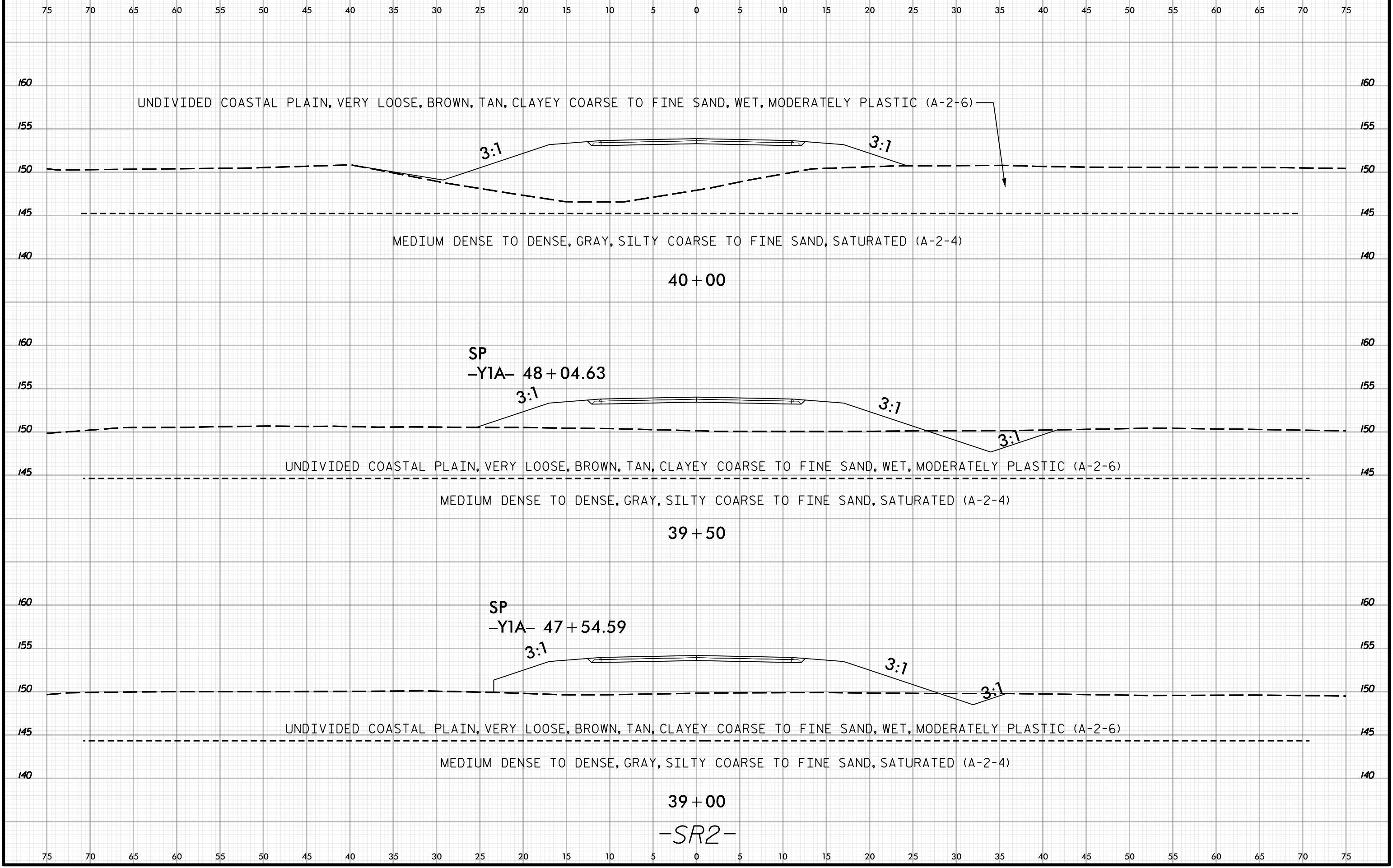



75 70 65 60 55 50 45 40 35 30 25 20 15 10 5 0 5 10 15 20 25 30 35 40 45 50 55 60 65 70 75

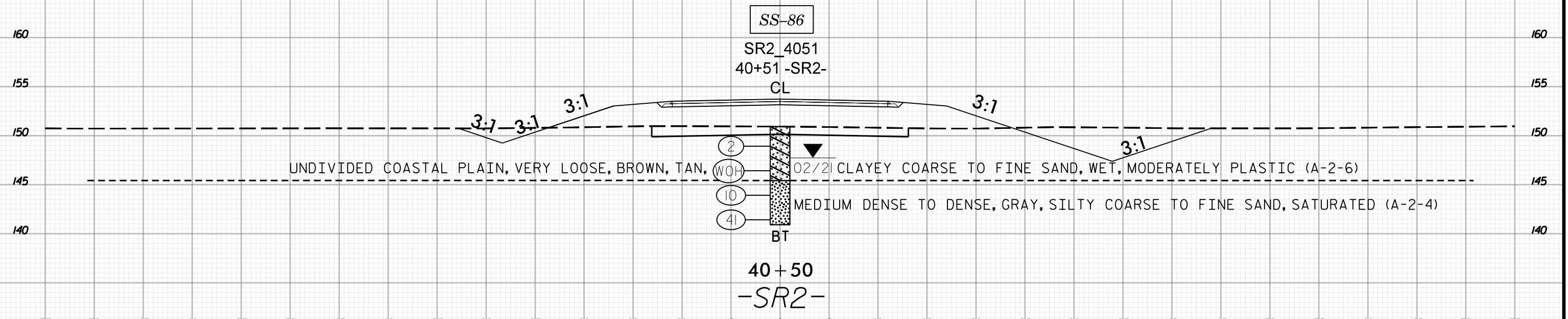
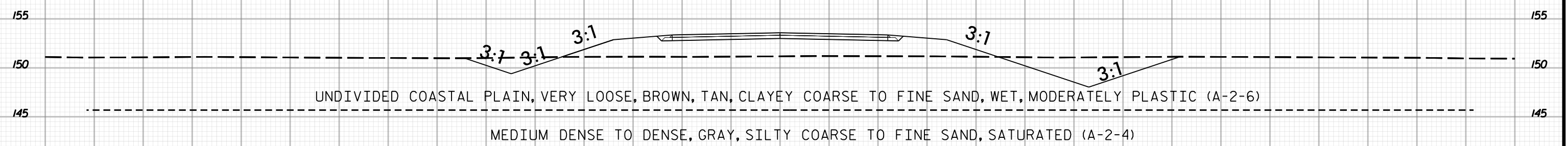
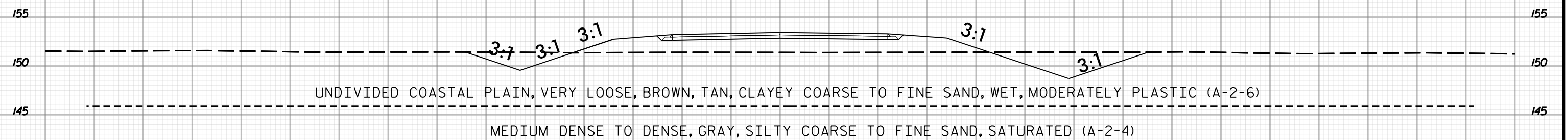

75 70 65 60 55 50 45 40 35 30 25 20 15 10 5 0 5 10 15 20 25 30 35 40 45 50 55 60 65 70 75



PROJ. REFERENCE NO.	SHEET NO.
I-5987A	1045

75 70 65 60 55 50 45 40 35 30 25 20 15 10 5 0 5 10 15 20 25 30 35 40 45 50 55 60 65 70 75

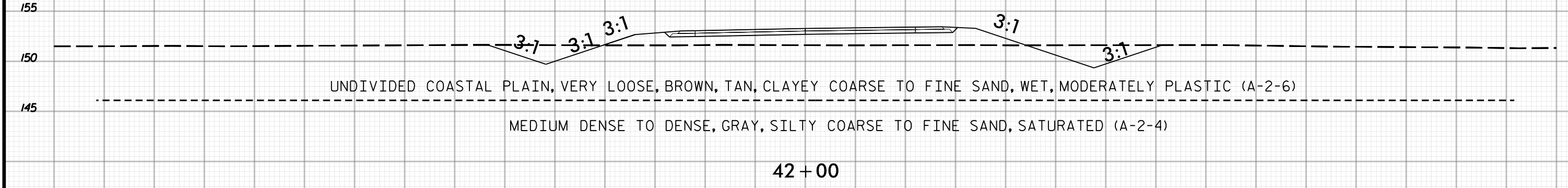
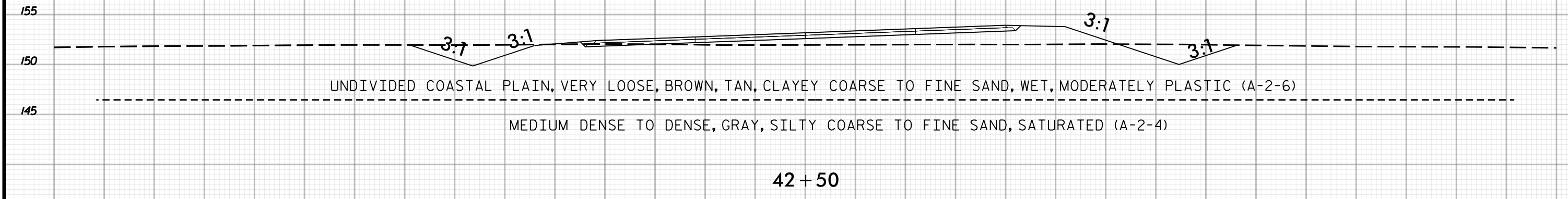
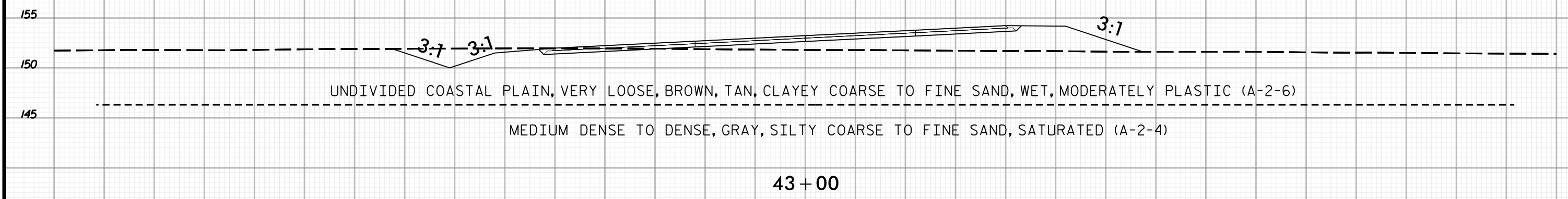

75 70 65 60 55 50 45 40 35 30 25 20 15 10 5 0 5 10 15 20 25 30 35 40 45 50 55 60 65 70 75

-SR2-



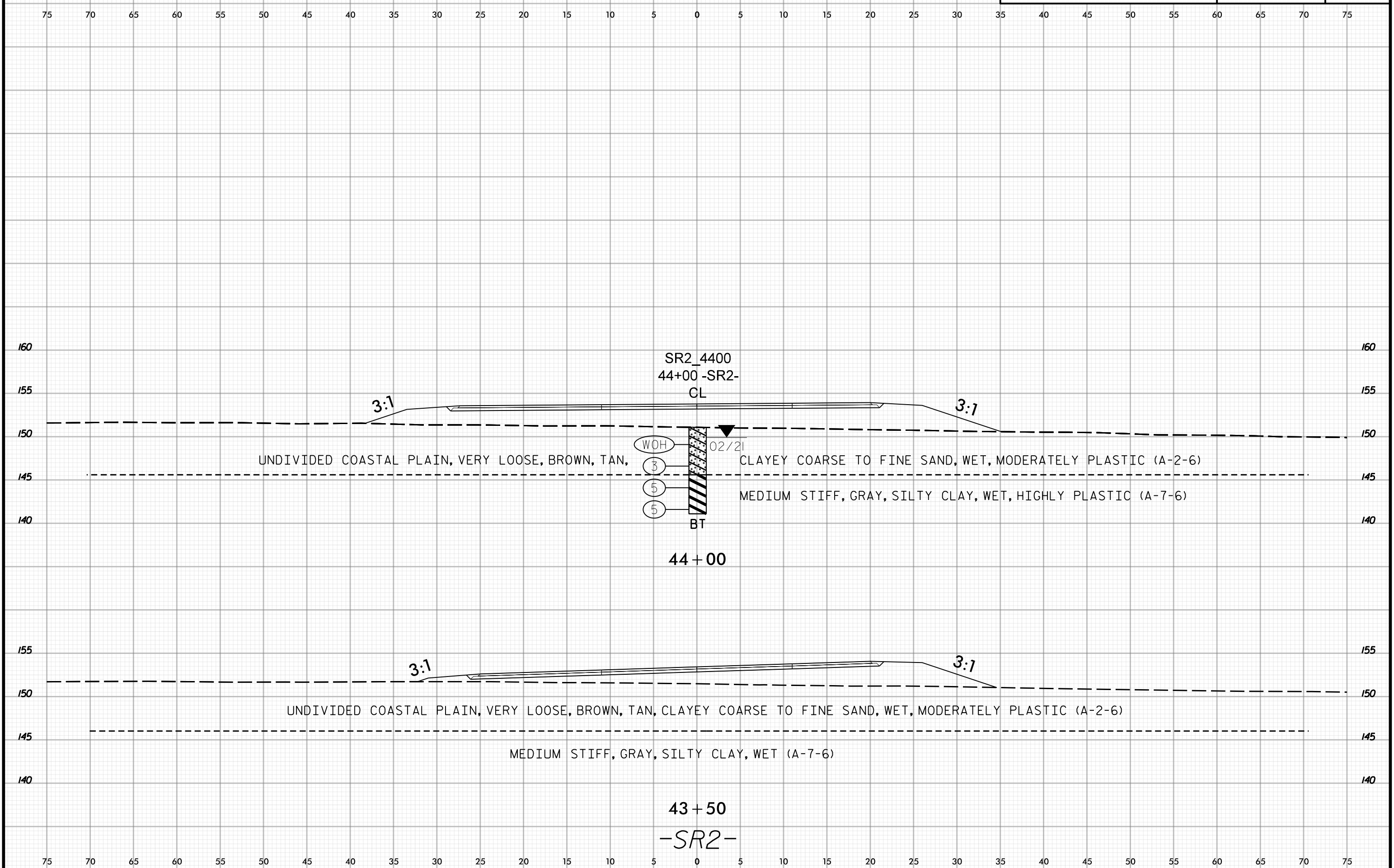

NORTH CAROLINA DEPARTMENT OF TRANSPORTATION  
DIVISION OF HIGHWAYS  
GEOTECHNICAL ENGINEERING UNIT  
SUBSURFACE INVESTIGATION

APPENDIX A

ADDITIONAL BORE LOGS  
(DRILLED OFF LIMITS OF CONSTRUCTION)

LABORATORY TESTING SUMMARY

REFERENCE: I-5987A

PROJECT: 47533.1.1

Prepared in the Office of:

**Terracon**

Consulting Engineers and Scientists  
2401 BRENTWOOD ROAD, SUITE 107  
RALEIGH, NORTH CAROLINA 27604  
NC REGISTERED ENGINEERING FIRM: F-0869  
NC REGISTERED GEOLOGIC FIRM: C-367

# GEOTECHNICAL BORING REPORT

## BORE LOG

WBS 47533.1.1		TIP I-5987		COUNTY ROBESON/CUMBERLAND		GEOLOGIST L. PUGH											
SITE DESCRIPTION I-95 CUMBERLAND/ROBESON COUNTIES FROM US 301 (EXIT 22) TO I-95 BUSINESS/US 301 (EXIT 40)							GROUND WTR (ft)										
BORING NO. Y2_3600		STATION 39+82		OFFSET 25 ft LT		ALIGNMENT -Y2-											
COLLAR ELEV. 143.7 ft		TOTAL DEPTH 10.0 ft		NORTHING 345,799		EASTING 2,001,524											
DRILL RIG/HAMMER EFF./DATE CAT4425 CME-55 87% 01/16/2019			DRILL METHOD MUD ROTARY			HAMMER TYPE AUTOMATIC											
DRILLER J. EDMONDSON		START DATE 01/14/20		COMP. DATE 01/14/20		SURFACE WATER DEPTH N/A											
ELEV (ft)	DRIVE ELEV (ft)	DEPTH (ft)	BLOW COUNT			BLOWS PER FOOT					SAMP. NO.	LOG	SOIL AND ROCK DESCRIPTION	DEPTH (ft)			
			0.5ft	0.5ft	0.5ft	0	25	50	75	100							
145	143.7	0.0	1	2	2									143.7	GROUND SURFACE	0.0	
														142.4	UNDIVIDED COASTAL PLAIN LOOSE, BROWN, SILTY FINE TO COARSE SAND, MOIST (A-2-4)	1.3	
140	139.9	3.8	WOH	2	3									140.7	SOFT TO MEDIUM STIFF, PURPLE GRAY, FINE TO COARSE SANDY CLAY, MOIST, MODERATELY PLASTIC (A-6)	3.0	
															MEDIUM STIFF TO STIFF, GRAY, SILTY CLAY, WET (A-7-6)		
135	135.2	8.5		4	6	7								133.7	Boring Terminated at Elevation 133.7 ft IN UNDIVIDED COASTAL PLAIN SANDY CLAY	10.0	

WBS 47533.1.1		TIP I-5987		COUNTY ROBESON/CUMBERLAND		GEOLOGIST C. FUTRAL												
SITE DESCRIPTION I-95 CUMBERLAND/ROBESON COUNTIES FROM US 301 (EXIT 22) TO I-95 BUSINESS/US 301 (EXIT 40)							GROUND WTR (ft)											
BORING NO. Y2_3900		STATION 42+82		OFFSET 24 ft LT		ALIGNMENT -Y2-												
COLLAR ELEV. 146.1 ft		TOTAL DEPTH 6.0 ft		NORTHING 345,613		EASTING 2,001,767												
DRILL RIG/HAMMER EFF./DATE HAND AUGER			DRILL METHOD HAND AUGER			HAMMER TYPE N/A												
DRILLER C. FUTRAL		START DATE 02/05/20		COMP. DATE 02/05/20		SURFACE WATER DEPTH N/A												
ELEV (ft)	DRIVE ELEV (ft)	DEPTH (ft)	BLOW COUNT			BLOWS PER FOOT					SAMP. NO.	LOG	SOIL AND ROCK DESCRIPTION	DEPTH (ft)				
			0.5ft	0.5ft	0.5ft	0	25	50	75	100								
150																		
145														146.1	GROUND SURFACE	0.0		
														144.6	ROADWAY EMBANKMENT MEDIUM DENSE, TAN, SILTY FINE SAND, MOIST, FEW CLAY NODULES (A-2-4)	1.5		
														142.1	UNDIVIDED COASTAL PLAIN LOOSE TO MEDIUM DENSE, TAN, RED, ORANGE, MOTTLED, CLAYEY FINE SAND, MOIST (A-2-6)	4.0		
														140.1	SOFT TO MEDIUM STIFF, GRAY, TAN, ORANGE, MOTTLED, SANDY FINE TO COARSE CLAY, MOIST TO WET (A-6)	6.0		
															Boring Terminated at Elevation 140.1 ft IN UNDIVIDED COASTAL PLAIN SANDY CLAY			

NCDOT BORE DOUBLE I5987\_GEO\_RDWY\_CATLIN\_GTM-DRILLED\_REVISED.GPJ\_NC\_DOT.GDT 11/8/21

LABORATORY TESTING SUMMARY

PROJECT NUMBER: 47533.1.2

TIP: I-5987A

COUNTY: ROBESON

DESCRIPTION: I-95 IMPROVEMENTS FROM SOUTH OF US 301 (EXIT 22) TO NORTH OF SR 1758 (McDUFFIE CROSSING RD.)

Table with columns: Sample No., Station, Alignment, Offset (feet), Depth Interval (feet), AASHTO Class., L.L., P.I., % by Weight (Coarse Sand, Fine Sand, Silt, Clay), % Retained #4 Sieve, % Passing (sieves) (#10, #40, #200), % Moisture, % Organic. Rows 1-40.

NP - NON-PLASTIC

Stephanie H. Huffman

Certified Lab Technician Signature

114-01-1203

Certification Number



### LABORATORY TESTING SUMMARY

PROJECT NUMBER: 47533.1.2

TIP: I-5987A

COUNTY: ROBESON

DESCRIPTION: I-95 IMPROVEMENTS FROM SOUTH OF US 301 (EXIT 22) TO NORTH OF SR 1758 (McDUFFIE CROSSING RD.)

Sample No.	Station	Alignment	Offset (feet)	Depth Interval (feet)	AASHTO Class.	L.L.	P.I.	% by Weight				% Retained #4 Sieve	% Passing (sieves)			% Moisture	% Organic
								Coarse Sand	Fine Sand	Silt	Clay		#10	#40	#200		
SS-81	185+00	-L-	CL	1.0 - 2.5	A-2-6 (0)	32	17	18.9	53.5	6.0	21.6	0	100	92	30	--	--
SS-82	185+00	-L-	CL	3.5 - 5.0	A-4 (0)	19	6	19.8	39.4	18.4	22.4	0	100	93	44	18.2	--
SS-83	209+00	-L-	5 RT	2.0 - 2.5	A-6 (4)	27	15	23.4	30.3	18.6	27.7	0	100	88	50	14.4	--
SS-84	99+00	-L-	65 LT	2.0 - 2.5	A-2-6 (0)	30	16	31.9	43.3	6.5	18.3	0	99	88	27	--	--
SS-86	40+51	-SR2-	CL	1.0 - 2.5	A-2-6 (0)	36	17	50.2	20.1	6.4	23.3	0	100	66	31	--	--
SS-87	34+44	-SR2-	6 LT	1.0 - 2.5	A-2-4 (0)	22	8	34.8	41.2	8.2	15.8	0	100	79	26	--	--
SS-89	30+11	-SR2-	CL	3.5 - 5.0	A-6 (7)	39	24	20.8	34.0	11.6	33.6	0	100	90	47	21.2	--
SS-90	18+75	-Y1ARPC-	23 LT	1.0 - 2.5	A-6 (2)	26	15	20.9	40.5	12.3	26.3	0	100	90	41	15.3	--
SS-91	25+21	-SR2-	CL	3.5 - 5.0	A-2-6 (0)	24	12	23.5	43.6	11.7	21.2	0	100	90	35	--	--
SS-92	14+97	-Y1ARPC-	48 RT	1.0 - 2.5	A-2-4 (0)	22	10	26.5	43.7	10.6	19.2	0	100	87	32	--	--
SS-93	21+60	-Y1ARPB-	5 RT	3.5 - 5.0	A-2-4 (0)	23	5	25.1	55.3	2.8	16.8	0	100	91	21	--	--
SS-94	19+86	-Y1ARPA-	1 RT	1.0 - 2.5	A-2-4 (0)	23	6	22.5	53.3	5.5	18.7	0	100	92	26	--	--
SS-95	23+37	-Y1ARPA-	6 RT	1.0 - 2.5	A-2-4 (0)	18	2	23.0	53.6	9.1	14.3	0	100	90	25	--	--
SS-96	39+81	-Y1A-	21 LT	1.0 - 2.5	A-7-6 (10)	44	26	21.9	25.2	11.6	41.3	0	100	90	54	26.6	--
SS-97	26+80	-Y2-	56 LT	3.5 - 5.0	A-7-6 (22)	56	38	19.8	18.8	16.8	44.6	0	100	90	64	22.0	--
SS-98	24+36	-Y3-	26 RT	1.0 - 2.5	A-2-6 (0)	29	14	67.2	16.0	4.2	12.6	0	99	55	18	--	--
SS-99	24+36	-Y3-	26 RT	8.5 - 10.0	A-2-4 (0)	21	9	47.6	26.7	16.4	9.3	0	100	72	28	--	--
SS-100	25+02	-Y3-	87 LT	3.5 - 5.0	A-6 (2)	24	13	37.5	22.4	19.8	20.3	0	100	77	43	20.4	--
SS-109	354+60	-L-	80 RT	1.0 - 2.5	A-6 (3)	30	16	32.4	26.2	13.7	27.7	0	100	80	43	20.6	--
SS-119T	28+91	-Y2-	19 RT	8.3 - 9.8	A-7-6 (13)	45	32	11.9	36.5	15.8	35.8	0	100	97	55	19.2	--
SS-120T	28+91	-Y2-	19 RT	18.3 - 19.8	A-2-6 (0)	32	16	8.4	64.5	6	21.1	0	100	98	29	42.3	--
SS-123T	111+29	-L-	10 RT	8.6 - 10.1	A-2-7 (5)	53	40	34.9	33.2	2.4	29.5	0	100	89	33	21.1	--
SS-124T	111+29	-L-	10 RT	18.6 - 20.1	A-2-6 (0)	31	12	65.3	21.3	1.9	11.5	0	99	69	13	31.4	--
SS-125T	366+42	-L-	9 RT	8.3 - 9.8	A-6 (3)	28	16	21.6	37.9	12.9	27.6	0	100	90	44	16.8	--
SS-126T	455+07	-L-	19 RT	18.4 - 19.9	A-2-6 (0)	28	12	26.0	47.8	6.1	20.1	0	99	83	27	35.5	--
S-1	44+00	-SR6-	85 LT	2.0 - 2.5	A-6 (5)	35	22	18.7	42.2	12.5	26.6	0	100	93	44	18.4	--
S-3	38+50	-SR2-	CL	3.0 - 3.5	A-2-4 (0)	17	3	31.7	45.6	7.5	15.2	0	100	86	26	19.6	--

NP - NON-PLASTIC

*Stephanie H. Huffman*

Certified Lab Technician Signature

114-01-1203

Certification Number



**LABORATORY TESTING SUMMARY**

PROJECT NUMBER: 47533.1.2

TIP: I-5987A

COUNTY: ROBESON

DESCRIPTION: I-95 IMPROVEMENTS FROM SOUTH OF US 301 (EXIT 22) TO NORTH OF SR 1758 (McDUFFIE CROSSING RD.)

Sample No.	Station	Alignment	Offset (feet)	Depth Interval (feet)	AASHTO Class.	L.L.	P.I.	% by Weight				% Retained #4 Sieve	% Passing (sieves)			% Moisture	% Organic
								Coarse Sand	Fine Sand	Silt	Clay		#10	#40	#200		
SS-1813	288+05	-L-	74 LT	28.5 - 30.0	A-7-5 (48)	73	43	3.3	4.1	12.4	80.2	0	100	98	94	53.2	--
SS-252	365+74	-L-	73 RT	3.5 - 5.0	A-2-4 (0)	26	8	26.7	41.4	18.2	13.7	0	100	90	35	21.2	--
SS-253	365+74	-L-	73 RT	8.5 - 10.0	A-7-6 (12)	49	30	28.7	20.1	8.1	43.1	0	97	82	52	46.7	--
SS-2309	365+85	-L-	8 LT	13.5 - 15.0	A-7-6 (18)	55	35	24.9	16.8	13.0	45.3	0	100	91	61	79.8	--
SS-247	365+86	-L-	82 LT	3.5 - 5.0	A-2-4 (0)	NP	NP	39.1	33.7	11.8	15.4	0	100	82	29	56.7	6.1
SS-248	365+86	-L-	82 LT	8.5 - 10.0	A-7-5 (30)	68	32	11.7	9.4	20.7	58.2	0	100	93	81	84.1	--
SS-2312	310+96	-L-	51' LT	13.5 - 15.0	A-2-6 (2)	36	18	28.6	37.7	6.4	27.3	0	100	85	35	26.5	--
SS-2301	454+49	-L-	84 RT	0.2 - 1.5	A-6 (3)	31	17	37.1	22.7	8.8	31.4	0	100	77	44	13.8	--
SS-2302	454+49	-L-	84 RT	8.5 - 10.0	A-7-6 (4)	42	25	38.6	28.8	7.7	24.9	0	100	75	37	16.6	--
SS-2303	454+49	-L-	84 RT	13.5 - 15.0	A-6 (2)	36	18	4.7	62.7	7.4	25.2	0	100	100	37	32.9	--
SS-241	455+42	-L-	77 LT	3.5 - 5.0	A-6 (0)	23	11	43.3	23.9	8.4	24.4	0	100	74	36	17.6	--
SS-242	455+42	-L-	77 LT	13.5 - 15.0	A-7-6 (11)	49	34	20.6	36.6	10.8	32.0	0	99	90	48	23.9	--
SS-2278	454+53	-L-	2 RT	4.2 - 5.0	ND	ND	ND	ND	ND	ND	ND	ND	ND	ND	ND	--	2.7
SS-24 FR	28+53	-Y2-	34 LT	18.5 - 20.0	A-2-4 (0)	NP	NP	16.3	62.7	8.5	12.5	0	100	95	23	40.1	--
SS-30 FR	29+81	-Y2-	CL	3.5 - 5.0	A-7-6 (14)	49	28	19.4	23.8	16.1	40.7	0	100	90	60	24.9	--
SS-501	31+07	-Y2-	33 LT	3.5 - 5.0	A-7-6 (14)	50	30	20.0	27.4	10.7	41.9	0	100	91	56	18.3	--
SS-502	31+07	-Y2-	33 LT	14.0 - 15.0	A-7-5 (17)	54	21	9.4	21.4	36.8	32.4	0	100	96	74	40.0	13.9
ST-100	31+07	-Y2-	33 LT	12.0 - 14.0	A-6 (11)	36	16	4.6	25.0	38.5	31.9	0	100	99	76	40.2	--
SS-2 FR	28+35	-Y3-	24 LT	3.5 - 5.0	A-6 (5)	35	21	35.2	21.7	8.6	34.5	0	100	78	47	21.2	--
SS-4 FR	28+35	-Y3-	24 LT	13.5 - 15.0	A-7-6 (9)	47	21	29.7	30.7	8.3	31.3	0	100	84	44	23.9	--
SS-520	32+01	-Y3-	25 LT	3.5 - 5.0	A-6 (2)	31	17	39.1	24.9	9.2	26.8	0	100	78	40	15.7	--
SS-522	32+01	-Y3-	25 LT	13.5 - 15.0	A-7-6 (10)	49	32	28.0	28.5	8.0	35.5	0	100	85	48	24.5	--

NP - NON-PLASTIC

\_\_\_\_\_  
 D. COUNCIL - F&R  
 Certified Lab Technician Signature

\_\_\_\_\_  
 101-02-0603  
 Certification Number



**LABORATORY TESTING SUMMARY**

PROJECT NUMBER: 47533.1.2

TIP: I-5987A

COUNTY: ROBESON

DESCRIPTION: I-95 IMPROVEMENTS FROM SOUTH OF US 301 (EXIT 22) TO NORTH OF SR 1758 (McDUFFIE CROSSING RD.)

Sample No.	Station	Alignment	Offset (feet)	Depth Interval (feet)	AASHTO Class.	L.L.	P.I.	% by Weight				% Retained #4 Sieve	% Passing (sieves)			% Moisture	% Organic
								Coarse Sand	Fine Sand	Silt	Clay		#10	#40	#200		
S-006	92+00	-L-	65 RT	0.0 - 3.0	A-7-6 (7)	51	30	28.6	31.9	6.6	32.9	0	100	98	41	21.0	--
S-007	92+00	-L-	65 RT	3.5 - 6.0	A-2-6 (0)	34	16	39.7	38.8	2.9	18.6	0	100	86	22	--	--
S-008	102+00	-L-	81 LT	0.0 - 1.0	A-6 (3)	34	17	25.3	36.7	9.3	28.7	0	100	90	40	--	--
S-009	102+00	-L-	81 LT	1.0 - 5.0	A-7-6 (10)	52	27	20.9	31.1	9.1	38.9	0	100	93	50	25.0	--
S-010	102+00	-L-	81 LT	5.0 - 6.0	A-2-6 (0)	29	11	37.4	42.8	2.3	17.5	0	100	86	20	--	--
S-011	107+00	-L-	80 RT	0.0 - 1.0	A-4 (0)	24	10	22.8	41.7	12.4	23.1	0	100	92	38	23.0	--
S-012	107+00	-L-	80 RT	1.5 - 2.5	A-6 (3)	29	15	20.6	38.9	11.1	29.4	0	100	92	43	--	--
S-013	112+00	-L-	100 RT	0.0 - 0.5	A-4 (0)	NP	NP	7.4	10.7	78.5	3.4	14	82	95	84	--	27.4
S-014	112+00	-L-	100 RT	0.5 - 1.5	A-6 (3)	27	16	20.8	40.0	12.9	26.3	0	100	94	42	21.0	--
SS-039	111+93	-L-	70 RT	0.0 - 1.5	A-4 (3)	23	9	25.1	13.2	53.8	7.9	0	99	84	63	--	--
SS-040	111+93	-L-	70 RT	14.6 - 15.1	A-6 (8)	30	17	17.2	17.7	53.0	12.1	0	100	93	66	--	--
SS-041	111+93	-L-	70 RT	19.6 - 21.1	A-2-6 (0)	30	14	54.4	23.9	3.5	18.2	0	100	75	22	28.0	--
SS-042	111+93	-L-	70 RT	24.6 - 26.1	A-3 (0)	NP	NP	56.1	39.4	2.5	2.0	0	100	80	5	--	--
SS-043	111+93	-L-	70 RT	34.6 - 36.1	A-3 (0)	NP	NP	52.5	44.4	2.1	1.0	0	100	81	3	--	--
SS-044	111+93	-L-	70 RT	39.6 - 41.1	A-3 (0)	NP	NP	34.5	58.5	4.1	2.9	0	98	88	8	--	--
SS-045	122+00	-L-	103 RT	0.0 - 1.5	A-6 (1)	26	12	24.3	36.9	9.4	29.4	0	100	91	41	21.0	--
SS-046	122+00	-L-	103 RT	5.0 - 5.7	A-2-4 (0)	NP	NP	51.7	33.2	2.1	13.0	0	99	77	15	--	--
SS-047	122+00	-L-	103 RT	10.1 - 10.7	A-4 (0)	NP	NP	28.5	8.9	54.6	8.0	0	99	86	63	45.0	--
SS-048	122+00	-L-	103 RT	14.2 - 15.7	A-2-4 (0)	NP	NP	68.2	18.6	5.9	7.3	0	94	55	14	--	--
SS-049	127+00	-L-	CL	4.4 - 5.9	A-6 (1)	23	11	19.1	40.6	17.2	23.2	0	100	94	44	16.0	--
S-015	127+00	-L-	105 RT	0.0 - 1.0	A-4 (1)	20	8	21.8	30.9	21.2	26.1	0	100	91	50	17.0	--
S-016	127+00	-L-	105 RT	5.5 - 6.5	A-2-4 (0)	NP	NP	26.0	55.5	4.1	14.4	0	100	91	19	--	--
SS-050	132+00	-L-	CL	0.8 - 1.5	A-4 (0)	NP	NP	10.4	21.2	61.3	7.1	0	100	96	71	28.0	--
SS-051	132+00	-L-	CL	9.0 - 10.5	A-2-4 (0)	NP	NP	34.8	44.0	8.5	12.8	0	100	86	24	--	--
SS-052	132+00	-L-	CL	14.0 - 15.5	A-3 (0)	NP	NP	68.6	27.3	1.1	3.0	0	100	67	5	--	--
SS-053	132+00	-L-	CL	19.0 - 20.5	A-2-4 (0)	NP	NP	80.0	10.1	4.0	5.9	1	87	39	11	--	--
SS-054	137+00	-L-	CL	0.0 - 1.5	A-4 (4)	27	10	11.8	30.3	24.7	33.2	0	100	95	62	13.0	--
SS-055	137+00	-L-	CL	13.7 - 14.8	A-2-4 (0)	NP	NP	4.2	78.4	4.3	13.1	0	100	99	22	--	--
S-017	137+00	-L-	103 RT	0.0 - 1.0	A-4 (0)	NP	NP	18.7	45.5	25.4	10.4	0	100	93	41	--	13.2
S-018	137+00	-L-	103 RT	1.0 - 2.0	A-4 (1)	23	10	16.9	42.3	18.3	22.5	0	100	93	46	15.0	--
SS-056	142+00	-L-	CL	0.0 - 1.5	A-2-4 (0)	NP	NP	30.1	42.2	18.6	9.0	0	100	89	31	--	--
SS-057	142+00	-L-	CL	3.9 - 5.4	A-6 (3)	35	16	27.2	33.3	12.2	27.3	0	100	89	42	21.0	--
SS-058	142+00	-L-	CL	8.9 - 10.4	A-2-4 (0)	NP	NP	64.0	24.4	2.6	9.0	0	100	82	12	--	--
SS-059	142+00	-L-	CL	13.9 - 15.2	A-7-5 (18)	49	18	3.7	13.2	51.6	31.5	0	99	99	85	127.0	--
S-019	142+00	-L-	104 RT	2.0 - 3.0	A-7-6 (11)	46	33	18.3	38.0	10.8	32.9	0	100	93	48	24.0	--
SS-060	147+00	-L-	CL	8.6 - 9.4	A-7-6 (10)	48	32	17.9	37.9	8.8	35.5	0	100	94	47	26.0	--
S-020	147+00	-L-	86 RT	0.5 - 1.5	A-2-4 (0)	NP	NP	48.8	38.0	9.0	4.2	18	79	71	16	--	--
S-021	147+00	-L-	86 RT	2.0 - 3.0	A-2-6 (1)	30	15	31.3	43.7	6.6	18.5	0	100	88	27	--	--
S-022	147+00	-L-	86 RT	3.5 - 4.5	A-2-6 (1)	36	18	37.4	33.3	6.8	22.5	0	100	80	31	--	--
SS-128	152+00	-L-	CL	0.0 - 1.5	A-2-4 (0)	NP	NP	33.8	37.4	19.8	9.0	0	100	84	32	29.0	4.7

NP - NON-PLASTIC

*[Signature]*  
 \_\_\_\_\_  
 Certified Lab Technician Signature  
 \_\_\_\_\_  
 Certification Number

**LABORATORY TESTING SUMMARY**

PROJECT NUMBER: 47533.1.2

TIP: I-5987A

COUNTY: ROBESON

DESCRIPTION: I-95 IMPROVEMENTS FROM SOUTH OF US 301 (EXIT 22) TO NORTH OF SR 1758 (McDUFFIE CROSSING RD.)

Sample No.	Station	Alignment	Offset (feet)	Depth Interval (feet)	AASHTO Class.	L.L.	P.I.	% by Weight				% Retained #4 Sieve	% Passing (sieves)			% Moisture	% Organic
								Coarse Sand	Fine Sand	Silt	Clay		#10	#40	#200		
SS-129	152+00	-L-	CL	4.9 - 6.4	A-2-4 (0)	NP	NP	35.2	46.9	5.4	12.5	0	100	81	21	--	--
SS-130	152+00	-L-	CL	9.9 - 11.4	A-7-6 (29)	71	49	20.8	19.0	36.8	23.5	0	99	83	64	--	--
SS-131	152+00	-L-	CL	14.9 - 16.4	A-6 (2)	31	16	25.7	34.6	15.8	23.9	2	92	92	41	32.0	--
SS-132	152+00	-L-	CL	19.9 - 21.4	A-3 (0)	NP	NP	79.3	17.0	1.2	2.5	0	99	37	4	--	--
SS-134	157+00	-L-	12 RT	5.0 - 6.5	A-7-6 (13)	53	32	24.6	24.8	8.6	42.0	0	100	86	53	32.0	--
S-023	157+00	-L-	91 RT	0.0 - 1.0	A-2-4 (0)	NP	NP	53.4	35.9	4.1	6.5	10	89	69	12	--	--
S-024	157+00	-L-	91 RT	1.5 - 2.5	A-2-4 (0)	25	4	37.7	42.7	3.2	16.4	0	100	84	21	--	--
S-025	157+00	-L-	91 RT	4.0 - 5.0	A-6 (5)	31	17	20.3	33.2	12.7	33.8	0	100	93	48	--	--
SS-135	162+00	-L-	CL	0.0 - 1.5	A-2-4 (0)	NP	NP	29.5	43.0	18.6	8.9	0	98	86	31	--	--
SS-136	162+00	-L-	CL	4.8 - 6.3	A-2-4 (0)	22	8	26.1	43.1	8.7	22.1	0	100	89	34	--	--
SS-137	162+00	-L-	CL	9.8 - 11.3	A-3 (0)	NP	NP	70.0	21.1	2.0	6.9	0	99	63	10	--	--
SS-138	162+00	-L-	CL	14.8 - 16.3	A-4 (0)	NP	NP	7.9	52.6	24.1	15.4	3	95	97	50	59.0	--
SS-139	162+00	-L-	CL	19.8 - 21.3	A-3 (0)	NP	NP	78.5	13.8	3.8	3.9	5	78	43	9	--	--
SS-141	167+00	-L-	1 RT	15.0 - 16.5	A-2-4 (0)	NP	NP	43.9	42.0	4.1	10.0	0	99	81	15	29.0	--
S-078	167+00	-L-	104 LT	2.0 - 3.0	A-6 (6)	27	14	19.1	16.5	55.6	8.9	0	100	90	65	--	--
S-079	167+00	-L-	104 LT	3.5 - 4.5	A-6 (10)	33	21	25.8	10.2	55.2	8.9	0	100	82	65	23.0	--
S-080	167+00	-L-	104 LT	5.5 - 6.0	A-6 (5)	37	23	24.6	36.5	15.1	23.8	0	100	87	42	--	--
S-026	167+00	-L-	117 RT	0.0 - 1.0	A-2-4 (0)	NP	NP	43.7	40.7	6.5	9.1	2	98	75	18	--	--
S-027	167+00	-L-	117 RT	2.0 - 3.0	A-6 (4)	34	21	26.3	34.4	14.9	24.4	7	93	89	42	13.0	--
S-028	167+00	-L-	117 RT	8.0 - 9.0	A-2-4 (0)	NP	NP	23.9	58.8	6.3	11.0	0	100	88	20	--	--
SS-143	172+00	-L-	1 RT	5.0 - 6.5	A-7-6 (9)	44	26	23.2	30.3	8.3	38.2	0	100	88	48	24.0	--
SS-144	172+00	-L-	1 RT	10.3 - 11.5	A-3 (0)	NP	NP	28.0	64.7	1.3	6.0	0	100	92	9	--	--
SS-145	172+00	-L-	1 RT	15.0 - 16.0	A-2-6 (1)	30	15	56.4	18.8	4.2	20.6	0	97	69	25	33.0	0.0
SS-146	172+00	-L-	1 RT	20.0 - 21.5	A-3 (0)	NP	NP	71.5	22.5	2.0	4.0	0	99	65	7	--	--
SS-147	177+00	-L-	CL	0.0 - 1.5	A-6 (7)	40	22	31.4	21.2	8.0	39.4	0	100	83	49	30.0	0.0
SS-148	177+00	-L-	CL	5.0 - 6.5	A-7-6 (14)	55	34	19.6	30.2	7.7	42.4	0	100	93	52	20.0	0.0
S-034	177+00	-L-	97 RT	0.0 - 3.0	A-2-4 (0)	25	7	16.9	54.1	7.5	21.5	0	100	94	31	--	--
S-035	177+00	-L-	97 RT	3.0 - 6.5	A-6 (6)	32	18	19.0	31.0	12.7	37.3	0	100	92	54	--	--
S-036	177+00	-L-	97 RT	6.5 - 9.0	A-6 (5)	38	23	28.2	32.9	10.0	28.8	0	100	89	41	--	--
SS-149	182+00	-L-	CL	0.0 - 1.5	A-2-4 (0)	19	4	35.1	41.0	7.1	16.8	0	98	83	26	--	--
SS-150	182+00	-L-	CL	5.2 - 6.7	A-7-6 (8)	52	33	13.4	46.6	2.6	37.4	0	100	96	42	19.0	--
SS-151	182+00	-L-	CL	10.2 - 11.7	A-2-4 (0)	NP	NP	27.1	58.2	1.7	13.0	0	100	92	15	--	--
SS-152	182+00	-L-	CL	15.2 - 16.7	A-2-4 (0)	27	9	45.1	33.2	3.6	18.1	0	100	84	22	--	--
S-030	182+00	-L-	102 RT	0.0 - 3.0	A-6 (4)	33	16	18.6	35.8	10.6	35.0	0	100	94	48	25.0	--
SS-011	197+00	-L-	2 RT	5.0 - 6.2	A-7-6 (5)	41	17	25.9	29.4	13.3	31.4	0	100	88	47	--	--
SS-012	197+00	-L-	2 RT	10.3 - 11.5	A-2-4 (0)	NP	NP	25.3	47.3	10.3	17.1	0	100	91	30	--	--
SS-013	197+00	-L-	2 RT	15.7 - 16.5	A-2-4 (0)	NP	NP	16.8	61.0	4.0	18.2	0	100	97	24	--	--
S-031	202+00	-L-	86 RT	0.0 - 6.0	A-6 (13)	32	19	8.4	15.2	59.9	16.5	0	100	97	78	21.0	--
SS-014	207+00	-L-	4 RT	0.3 - 1.8	A-2-4 (0)	NP	NP	55.6	31.0	4.4	9.0	0	99	67	16	--	--
SS-015	207+00	-L-	4 RT	5.2 - 6.7	A-6 (7)	40	21	25.8	26.7	16.0	21.4	0	100	86	52	--	--

NP - NON-PLASTIC

*Michael P. Keson*  
Certified Lab Technician Signature

Certification Number

### LABORATORY TESTING SUMMARY

PROJECT NUMBER: 47533.1.2

TIP: I-5987A

COUNTY: ROBESON

DESCRIPTION: I-95 IMPROVEMENTS FROM SOUTH OF US 301 (EXIT 22) TO NORTH OF SR 1758 (McDUFFIE CROSSING RD.)

Sample No.	Station	Alignment	Offset (feet)	Depth Interval (feet)	AASHTO Class.	L.L.	P.I.	% by Weight				% Retained #4 Sieve	% Passing (sieves)			% Moisture	% Organic
								Coarse Sand	Fine Sand	Silt	Clay		#10	#40	#200		
SS-016	207+00	-L-	4 RT	10.8 - 11.7	A-7-6 (12)	43	24	7.4	35.2	18.9	38.5	0	100	98	61	18.0	--
S-029	217+00	-L-	116 RT	0.0 - 6.0	A-2-6 (1)	29	14	48.7	17.7	9.3	24.4	0	99	67	35	19.0	--
SS-017	222+00	-L-	8 RT	0.0 - 1.5	A-2-4 (0)	21	5	18.7	53.4	7.7	20.1	0	100	93	30	--	--
SS-018	222+00	-L-	8 RT	4.7 - 6.2	A-6 (7)	39	20	21.8	28.6	11.1	38.5	0	100	89	53	--	--
SS-019	222+00	-L-	8 RT	10.3 - 11.2	A-3 (0)	NP	NP	57.4	36.6	2.1	3.9	0	99	69	7	--	--
SS-020	222+00	-L-	8 RT	14.7 - 15.2	A-2-4 (0)	25	7	10.8	61.0	6.0	22.3	0	100	97	30	--	--
SS-021	227+00	-L-	9 RT	0.0 - 1.5	A-4 (0)	21	6	19.3	31.3	28.3	21.1	0	100	89	53	17.0	3.9
SS-022	227+00	-L-	9 RT	9.6 - 11.1	A-2-4 (0)	23	5	30.3	47.9	3.0	18.9	0	100	91	23	--	--
SS-023	227+00	-L-	9 RT	14.6 - 16.1	A-2-4 (0)	NP	NP	35.3	46.7	12.2	5.8	0	100	96	20	--	1.6
S-037	227+00	-L-	96 LT	0.0 - 4.0	A-2-4 (0)	18	1	52.1	30.3	17.0	0.6	11	87	67	19	--	--
S-038	227+00	-L-	96 LT	4.0 - 7.0	A-4 (1)	19	8	21.8	31.9	23.4	22.9	2	98	89	50	--	--
SS-024	232+00	-L-	10 RT	1.0 - 1.5	A-2-4 (0)	NP	NP	29.5	51.3	13.3	5.9	0	100	85	23	--	--
SS-025	232+00	-L-	10 RT	4.6 - 6.1	A-7-6 (6)	42	28	14.5	46.0	5.2	34.3	0	100	95	41	--	--
SS-026	232+00	-L-	10 RT	9.8 - 11.3	A-2-4 (0)	22	7	30.2	45.8	4.7	19.2	0	99	90	25	--	--
SS-027	232+00	-L-	10 RT	14.8 - 16.3	A-2-4 (0)	NP	NP	38.9	43.6	9.7	7.8	0	96	86	19	--	1.3
SS-028	232+00	-L-	10 RT	19.8 - 21.3	A-2-4 (0)	NP	NP	59.3	28.2	7.1	5.4	4	89	62	14	--	--
SS-029	242+00	-L-	12 RT	0.0 - 1.5	A-6 (2)	31	12	39.4	21.5	19.8	19.3	0	100	76	42	18.0	5.2
SS-030	242+00	-L-	12 RT	4.7 - 6.2	A-7-6 (18)	60	36	29.9	14.2	10.6	45.3	0	100	82	58	--	--
SS-031	242+00	-L-	12 RT	10.0 - 11.5	A-2-4 (0)	NP	NP	74.0	16.2	0.8	9.0	0	99	53	10	--	--
SS-032	242+00	-L-	12 RT	20.0 - 21.5	A-2-4 (0)	NP	NP	68.7	18.4	8.9	4.1	0	99	53	14	--	1.1
S-039	247+00	-L-	92 LT	0.0 - 5.0	A-2-4 (0)	NP	NP	60.1	25.4	5.0	9.5	4	94	61	16	--	--
S-040	247+00	-L-	92 LT	5.0 - 6.0	A-7-6 (6)	46	28	16.9	44.7	3.3	35.0	0	100	94	40	--	--
S-041	247+00	-L-	92 LT	6.0 - 8.0	A-2-4 (0)	NP	NP	41.5	35.8	8.1	14.6	0	100	76	26	--	--
SS-033	252+00	-L-	12 RT	0.0 - 1.5	A-4 (0)	NP	NP	13.1	14.3	64.3	8.2	0	100	82	74	29.0	6.7
SS-034	252+00	-L-	12 RT	4.7 - 6.2	A-2-4 (0)	21	4	36.5	43.7	6.7	13.1	0	100	80	22	--	--
SS-035	252+00	-L-	12 RT	14.8 - 16.3	A-2-4 (0)	NP	NP	26.0	54.2	3.8	16.0	0	100	93	21	--	--
S-042	251+99	-L-	88 LT	4.0 - 5.0	A-4 (0)	NP	NP	16.9	28.0	44.2	10.8	1	98	92	58	--	16.0
S-088	252+01	-L-	117 RT	3.5 - 4.0	A-2-4 (0)	NP	NP	29.0	38.7	14.7	17.6	0	100	88	35	--	7.3
S-206	252+01	-L-	117 RT	4.5 - 5.5	A-2-4 (0)	18	5	40.4	33.6	9.9	16.1	0	100	79	28	--	--
S-032	256+99	-L-	88 LT	0.0 - 6.0	A-2-6 (0)	26	11	23.7	46.9	9.7	19.8	0	100	91	32	15.0	--
SS-036	262+00	-L-	CL	0.0 - 1.5	A-4 (0)	23	6	16.5	49.1	15.2	19.2	0	100	94	37	22.0	--
SS-037	262+00	-L-	CL	5.1 - 6.6	A-2-4 (0)	NP	NP	17.9	63.6	7.3	11.1	0	100	94	20	--	--
SS-038	262+00	-L-	CL	10.1 - 11.6	A-2-4 (0)	NP	NP	16.8	64.5	4.6	14.1	0	100	95	20	--	--
S-043	267+00	-L-	87 LT	0.0 - 2.0	A-4 (0)	14	3	20.9	43.5	18.7	16.9	0	100	92	38	--	--
S-044	267+00	-L-	87 LT	2.0 - 6.0	A-6 (2)	25	12	22.2	37.6	13.5	26.8	0	100	90	44	--	--
S-203	277+00	-L-	81 RT	0.5 - 1.5	A-6 (2)	25	13	22.7	31.8	18.0	27.5	0	100	88	47	12.0	--
S-204	277+00	-L-	81 RT	3.0 - 4.0	A-6 (1)	24	13	28.2	36.6	11.9	23.4	0	100	86	36	--	--
S-205	277+00	-L-	81 RT	4.5 - 5.5	A-2-4 (0)	20	8	33.3	37.3	11.4	18.0	0	100	84	31	--	--
SS-061	297+00	-L-	91 RT	0.0 - 1.5	A-2-4 (0)	NP	NP	30.5	45.4	9.0	15.1	0	100	84	26	--	--
SS-062	297+00	-L-	91 RT	4.5 - 5.5	A-6 (2)	26	14	28.2	33.8	13.8	24.1	0	100	84	40	14.0	--

NP - NON-PLASTIC

  
 Certified Lab Technician Signature

Certification Number

**LABORATORY TESTING SUMMARY**

PROJECT NUMBER: 47533.1.2

TIP: I-5987A

COUNTY: ROBESON

DESCRIPTION: I-95 IMPROVEMENTS FROM SOUTH OF US 301 (EXIT 22) TO NORTH OF SR 1758 (McDUFFIE CROSSING RD.)

Sample No.	Station	Alignment	Offset (feet)	Depth Interval (feet)	AASHTO Class.	L.L.	P.I.	% by Weight				% Retained #4 Sieve	% Passing (sieves)			% Moisture	% Organic
								Coarse Sand	Fine Sand	Silt	Clay		#10	#40	#200		
SS-063	297+00	-L-	91 RT	9.5 - 11.0	A-4 (0)	23	5	1.5	65.7	3.6	29.2	0	100	99	35	--	--
SS-064	297+00	-L-	91 RT	14.5 - 15.6	A-7-6 (32)	55	33	2.6	12.1	23.5	61.9	0	100	99	89	65.0	--
SS-065	297+00	-L-	91 RT	19.5 - 21.0	A-2-4 (0)	NP	NP	55.9	20.8	9.6	13.7	0	97	69	24	28.0	--
SS-066	302+00	-L-	81 RT	4.7 - 6.2	A-2-6 (0)	29	15	79.0	8.9	3.1	8.9	0	99	33	12	--	--
SS-067	302+00	-L-	81 RT	24.7 - 26.2	A-7-6 (43)	66	41	4.0	5.8	34.5	55.7	0	100	98	93	32.0	--
SS-068	307+00	-L-	111 RT	0.0 - 1.5	A-4 (0)	24	7	21.6	42.9	19.1	16.4	0	100	89	37	41.0	4.4
SS-069	307+00	-L-	111 RT	4.0 - 5.2	A-7-6 (39)	68	41	1.6	16.9	26.5	55.0	0	100	99	85	39.0	--
SS-070	307+00	-L-	111 RT	10.2 - 11.2	A-2-4 (0)	NP	NP	60.6	35.4	2.6	0.0	0	98	64	20	--	--
SS-071	307+00	-L-	111 RT	13.7 - 15.2	A-3 (0)	NP	NP	62.0	35.4	2.6	0.0	0	100	78	3	--	--
SS-072	307+00	-L-	111 RT	18.7 - 20.2	A-2-6 (0)	31	17	65.3	14.4	8.5	11.8	1	90	53	21	--	--
SS-073	307+00	-L-	111 RT	23.7 - 25.2	A-6 (16)	38	21	2.2	20.1	23.3	54.4	0	100	99	82	21.0	--
SS-087	317+00	-L-	79 LT	4.8 - 6.3	--	--	--	--	--	--	--	--	--	--	--	--	7.1
SS-084	322+00	-L-	77 LT	4.7 - 6.2	A-6 (1)	28	11	8.7	57.3	8.8	25.2	0	100	98	37	39.0	--
SS-085	322+00	-L-	77 LT	9.7 - 11.2	A-6 (4)	33	13	15.8	33.0	19.7	31.5	0	100	96	54	--	--
SS-086	322+00	-L-	77 LT	14.7 - 16.2	A-3 (0)	NP	NP	63.5	27.0	4.5	5.0	0	99	73	10	--	--
SS-081	332+00	-L-	89 LT	5.0 - 6.5	A-7-5 (45)	75	39	1.8	3.7	38.8	55.8	0	100	99	96	55.0	--
SS-082	332+00	-L-	89 LT	10.0 - 11.5	A-2-6 (0)	34	13	61.3	10.6	14.4	13.7	16	71	54	29	--	--
SS-083	332+00	-L-	89 LT	20.0 - 21.5	A-6 (5)	38	19	36.5	20.6	16.0	26.9	0	88	78	45	--	--
SS-079	342+00	-L-	79 LT	4.9 - 6.4	A-6 (16)	40	21	6.7	16.6	30.3	46.4	0	100	94	79	18.0	--
SS-080	342+00	-L-	79 LT	14.9 - 16.4	A-2-4 (0)	NP	NP	48.6	36.6	3.9	10.9	0	98	75	15	--	--
SS-077	353+00	-L-	96 LT	5.0 - 6.5	A-6 (9)	37	23	21.1	26.0	14.4	38.5	0	100	91	55	32.0	--
SS-078	353+00	-L-	96 LT	10.0 - 11.5	A-2-4 (0)	22	8	64.6	13.8	5.9	15.7	1	99	65	23	--	--
SS-252C	363+00	-L-	81 RT	3.7 - 5.2	A-2-4 (0)	NP	NP	45.6	40.6	2.6	11.2	0	100	83	15	--	--
SS-253C	363+00	-L-	81 RT	8.7 - 10.2	A-2-4 (0)	NP	NP	36.5	32.4	8.6	22.5	0	96	86	32	--	--
SS-254	363+00	-L-	81 RT	18.7 - 20.2	A-2-4 (0)	NP	NP	56.4	32.5	2.9	8.2	0	100	56	12	--	--
S-099	368+00	-L-	91 RT	0.0 - 0.5	A-4 (0)	23	5	17.0	41.6	12.2	29.2	0	100	94	48	--	4.5
SS-074	373+00	-L-	83 LT	5.0 - 6.5	A-7-6 (17)	53	40	14.8	38.8	14.9	31.6	0	100	91	55	29.0	--
SS-075	373+00	-L-	83 LT	14.6 - 16.1	A-7-5 (14)	51	20	12.5	21.7	35.1	30.7	0	100	95	68	--	--
SS-076	373+00	-L-	83 LT	19.6 - 20.1	A-3 (0)	NP	NP	85.1	11.8	2.5	0.6	0	91	39	3	--	--
SS-010	378+00	-L-	79 LT	19.9 - 21.4	A-6 (13)	37	18	9.5	19.4	24.5	46.6	0	100	95	76	--	--
SS-008C	383+00	-L-	89 LT	0.0 - 1.5	A-6 (6)	39	20	34.8	19.7	18.4	27.0	0	99	76	50	--	--
SS-009C	383+00	-L-	89 LT	10.0 - 11.5	A-3 (0)	NP	NP	87.4	9.0	2.7	1.0	0	98	47	4	--	--
SS-005C	393+00	-L-	78 LT	0.5 - 1.5	A-6 (3)	31	14	40.5	16.9	13.4	29.1	0	99	74	45	--	--
SS-006C	393+00	-L-	78 LT	9.9 - 11.4	A-3 (0)	NP	NP	77.8	16.5	4.0	1.0	0	95	44	6	--	--
SS-007C	393+00	-L-	78 LT	14.9 - 16.4	A-2-4 (0)	NP	NP	41.0	48.2	3.2	7.6	0	99	84	12	--	--
SS-001C	402+00	-L-	93 LT	0.0 - 1.5	A-2-4 (0)	NP	NP	45.1	24.3	15.4	15.2	0	99	70	33	--	--
SS-002C	402+00	-L-	93 LT	4.9 - 6.4	A-2-7 (2)	43	25	57.0	17.3	4.5	21.2	0	99	64	26	--	--
SS-003C	402+00	-L-	93 LT	9.9 - 11.4	A-2-4 (0)	NP	NP	12.2	79.1	2.5	6.2	0	100	96	10	--	--
SS-004C	402+00	-L-	93 LT	14.9 - 16.4	A-2-4 (0)	NP	NP	33.5	48.7	6.9	10.8	0	98	89	19	--	--
S-160	407+00	-L-	2 RT	4.5 - 5.0	A-2-6 (1)	38	21	53.9	21.6	6.1	18.4	0	99	62	26	--	--

NP - NON-PLASTIC

*Michael D. Mason*  
 Certified Lab Technician Signature

\_\_\_\_\_  
 Certification Number

### LABORATORY TESTING SUMMARY

PROJECT NUMBER: 47533.1.2

TIP: I-5987A

COUNTY: ROBESON

DESCRIPTION: I-95 IMPROVEMENTS FROM SOUTH OF US 301 (EXIT 22) TO NORTH OF SR 1758 (McDUFFIE CROSSING RD.)

Sample No.	Station	Alignment	Offset (feet)	Depth Interval (feet)	AASHTO Class.	L.L.	P.I.	% by Weight				% Retained #4 Sieve	% Passing (sieves)			% Moisture	% Organic
								Coarse Sand	Fine Sand	Silt	Clay		#10	#40	#200		
SS-088	407+00	-L-	77 RT	4.8 - 6.3	A-2-7 (3)	48	30	56.6	13.0	4.8	25.6	1	99	63	31	--	--
SS-089	407+00	-L-	77 RT	9.8 - 11.3	A-3 (0)	NP	NP	45.6	47.8	2.6	4.0	0	99	79	7	--	--
S-161	412+00	-L-	2 RT	1.0 - 1.5	A-2-4 (0)	NP	NP	54.4	27.8	4.5	13.3	2	98	69	20	--	--
S-162	412+00	-L-	2 RT	2.5 - 3.5	A-7-6 (9)	46	25	30.8	19.6	10.6	39.0	1	99	80	52	--	--
SS-090	417+00	-L-	92 RT	4.9 - 6.4	A-7-6 (6)	43	25	37.1	22.9	11.0	29.0	0	100	78	43	--	--
SS-091	417+00	-L-	92 RT	9.9 - 11.4	A-2-6 (1)	30	16	44.6	24.6	8.1	22.7	0	98	71	33	17.0	--
SS-095	427+00	-L-	76 RT	4.9 - 6.4	A-6 (4)	38	20	39.6	22.6	10.2	27.6	0	99	74	42	18.0	--
SS-096	427+00	-L-	76 RT	9.9 - 11.4	A-7-6 (15)	51	33	21.3	28.5	13.9	36.3	0	100	86	56	--	--
SS-097	427+00	-L-	76 RT	14.9 - 16.4	A-2-4 (0)	NP	NP	1.1	78.9	5.0	15.1	0	100	100	23	--	--
SS-098	427+00	-L-	76 RT	19.9 - 21.4	A-3 (0)	NP	NP	21.8	70.0	3.2	5.0	0	99	99	9	--	--
SS-092	437+00	-L-	105 RT	4.9 - 6.4	A-2-4 (0)	23	6	61.7	19.4	4.0	15.0	0	99	82	64	--	--
SS-093	437+00	-L-	105 RT	9.9 - 11.4	A-7-6 (18)	54	31	24.6	15.4	11.5	48.5	0	100	82	64	--	--
SS-094	437+00	-L-	105 RT	19.9 - 21.4	A-2-4 (0)	NP	NP	1.1	85.8	2.1	11.0	0	100	100	14	--	--
S-163	442+00	-L-	2 RT	0.5 - 1.0	A-2-4 (0)	NP	NP	50.0	35.8	5.8	8.3	0	100	76	17	--	--
S-164	442+00	-L-	2 RT	3.0 - 3.5	A-6 (5)	38	22	37.8	23.5	12.2	26.5	0	99	74	42	--	--
S-165	442+00	-L-	2 RT	5.0 - 5.5	A-2-6 (1)	33	19	51.7	24.6	6.2	17.4	0	99	64	26	--	--
S-166	442+00	-L-	2 RT	9.5 - 10.0	A-2-4 (0)	NP	NP	74.1	14.1	0.6	11.2	0	97	40	13	--	--
SS-300	447+00	-L-	78 LT	3.3 - 4.8	A-2-6 (2)	34	17	47.5	19.2	8.1	25.2	0	98	68	36	--	--
S-168	472+00	-L-	88 LT	0.5 - 1.0	A-2-4 (0)	23	8	64.0	18.3	2.8	14.9	0	96	54	20	--	--
S-169	472+00	-L-	88 LT	2.0 - 2.5	A-2-6 (2)	36	14	56.3	15.4	7.0	21.3	0	98	62	30	--	--
S-170	472+00	-L-	88 LT	3.5 - 4.0	A-2-7 (0)	42	26	77.8	18.7	26.2	29.7	0	99	36	6	--	--
S-167	477+00	-L-	87 LT	2.0 - 2.5	A-4 (1)	29	10	32.7	29.0	17.8	20.5	0	99	81	44	--	6.7
S-089	477+00	-L-	92 RT	0.0 - 4.0	A-3 (0)	NP	NP	55.9	35.7	3.3	5.1	0	99	60	10	--	--
S-090	477+00	-L-	92 RT	4.0 - 6.0	A-2-6 (1)	31	16	40.1	29.8	9.9	20.2	0	100	74	33	--	--
S-171	482+00	-L-	78 LT	1.0 - 1.5	A-2-4 (0)	NP	NP	55.2	29.2	3.7	11.9	0	99	69	18	--	--
S-172	482+00	-L-	78 LT	2.0 - 2.5	A-2-4 (0)	NP	NP	55.2	30.2	5.7	9.0	0	99	68	17	--	--
S-173	482+00	-L-	78 LT	3.0 - 3.5	A-2-6 (1)	33	14	50.9	19.1	8.2	21.8	0	98	67	32	--	--
S-174	482+00	-L-	78 LT	5.5 - 6.0	A-2-4 (0)	30	9	71.1	14.1	2.0	12.8	0	97	48	15	--	--
S-091	487+00	-L-	87 RT	0.0 - 1.0	A-2-4 (0)	NP	NP	45.5	31.4	10.9	12.2	0	99	73	26	--	--
S-092	487+00	-L-	87 RT	1.0 - 6.0	A-2-6 (2)	34	19	40.8	27.0	8.0	24.2	0	100	76	35	--	--
S-093	492+00	-L-	92 RT	1.0 - 8.0	A-7-6 (8)	43	28	33.7	22.4	13.7	30.2	0	100	79	47	--	--
S-207	36+59	-SR2-	CL	1.0 - 2.0	A-6 (2)	32	14	29.6	30.2	10.8	29.4	0	100	83	42	--	--
S-208	36+59	-SR2-	CL	3.0 - 4.0	A-2-4 (0)	23	10	34.9	32.3	12.8	20.0	1	99	79	35	--	--
S-209	36+59	-SR2-	CL	6.5 - 7.5	A-2-4 (0)	21	8	37.2	32.0	11.1	19.8	1	99	78	33	--	--
S-210	19+08	-SR2-	29 RT	1.5 - 2.5	A-2-4 (0)	22	8	44.9	29.8	7.3	18.0	0	100	68	28	--	--
S-211	19+08	-SR2-	29 RT	4.5 - 5.5	A-2-6 (1)	30	15	50.5	25.6	4.9	19.0	0	100	65	25	--	--
S-212	19+08	-SR2-	29 RT	6.0 - 7.0	A-2-4 (0)	21	6	76.1	10.5	2.5	10.9	0	99	46	14	--	--
S-112	19+55	-Y1A-	25 RT	1.5 - 3.5	A-2-4 (0)	NP	NP	22.3	46.4	15.2	16.1	0	100	89	34	--	--
S-113	19+55	-Y1A-	25 RT	3.5 - 6.0	A-2-4 (0)	23	9	29.5	38.5	11.5	20.5	0	100	84	34	--	--
SS-104	27+02	-Y1A-	4 RT	0.0 - 1.5	A-4 (1)	21	7	7.2	45.4	24.7	22.7	0	100	99	50	18.0	--

NP - NON-PLASTIC

*Michael D. Kason*  
 \_\_\_\_\_  
 Certified Lab Technician Signature

\_\_\_\_\_  
 Certification Number

**LABORATORY TESTING SUMMARY**

PROJECT NUMBER: 47533.1.2

TIP: I-5987A

COUNTY: ROBESON

DESCRIPTION: I-95 IMPROVEMENTS FROM SOUTH OF US 301 (EXIT 22) TO NORTH OF SR 1758 (McDUFFIE CROSSING RD.)

Sample No.	Station	Alignment	Offset (feet)	Depth Interval (feet)	AASHTO Class.	L.L.	P.I.	% by Weight				% Retained #4 Sieve	% Passing (sieves)			% Moisture	% Organic
								Coarse Sand	Fine Sand	Silt	Clay		#10	#40	#200		
SS-105	27+02	-Y1A-	4 RT	4.4 - 5.9	A-6 (1)	24	11	15.3	46.0	13.7	25.1	0	100	96	40	--	--
SS-106	27+02	-Y1A-	4 RT	10.2 - 10.9	A-2-4 (0)	NP	NP	4.3	83.1	4.2	8.4	0	100	99	14	--	--
SS-107	27+02	-Y1A-	4 RT	14.4 - 15.9	A-2-4 (0)	NP	NP	44.5	32.1	7.1	16.4	0	100	81	25	--	--
SS-108	33+06	-Y1A-	15 RT	0.0 - 1.5	A-4 (0)	21	7	23.9	38.9	20.1	17.1	0	100	89	39	--	--
SS-109	33+06	-Y1A-	15 RT	3.4 - 4.9	A-2-6 (1)	29	13	33.8	33.7	5.7	26.8	0	100	85	33	--	--
SS-110	33+06	-Y1A-	15 RT	8.4 - 9.9	A-2-4 (0)	NP	NP	19.1	63.6	4.8	12.6	0	100	91	19	--	--
SS-111	33+06	-Y1A-	15 RT	13.4 - 14.9	A-7-6 (18)	48	27	10.4	21.9	14.8	52.9	0	100	96	70	--	--
SS-112	33+06	-Y1A-	15 RT	23.4 - 24.9	A-3 (0)	NP	NP	32.9	60.1	1.4	5.6	0	100	86	9	--	--
SS-113	33+06	-Y1A-	15 RT	28.4 - 29.9	A-7-6 (23)	48	25	3.1	16.0	30.4	50.5	0	100	98	87	--	--
SS-114	44+16	-Y1A-	23 LT	0.0 - 1.5	A-2-4 (0)	19	6	34.3	36.4	9.6	19.7	0	100	81	31	--	--
SS-116	44+16	-Y1A-	23 LT	10.2 - 10.9	A-2-4 (0)	NP	NP	64.9	24.2	1.4	9.5	1	99	71	11	--	--
SS-117	44+16	-Y1A-	23 LT	19.4 - 20.9	A-2-4 (0)	20	5	52.4	25.4	3.7	18.5	0	99	75	23	--	--
SS-118	44+16	-Y1A-	23 LT	24.4 - 25.9	A-3 (0)	NP	NP	81.7	13.5	2.4	2.5	0	98	45	5	--	--
SS-119	44+16	-Y1A-	23 LT	34.4 - 35.9	A-7-5 (17)	56	24	8.3	30.9	37.7	23.2	0	100	95	68	--	--
SS-120	44+16	-Y1A-	23 LT	44.4 - 45.9	A-2-7 (28)	56	25	2.8	7.0	36.0	54.2	0	100	98	93	--	--
SS-121	50+30	-Y1A-	29 RT	0.0 - 1.5	A-2-4 (0)	22	9	31.1	36.0	12.2	20.6	0	100	84	34	--	--
SS-122	50+30	-Y1A-	29 RT	4.1 - 5.6	A-2-4 (0)	24	7	57.1	22.9	2.4	17.6	0	100	79	20	--	--
SS-123	50+30	-Y1A-	29 RT	9.1 - 10.6	A-7-6 (47)	70	49	2.5	11.3	23.9	62.3	0	100	99	88	--	--
SS-124	25+87	-Y1RPA-	8 RT	0.0 - 1.5	A-4 (0)	25	10	21.7	43.6	11.1	23.6	0	100	92	36	--	--
SS-125	25+87	-Y1RPA-	8 RT	8.5 - 10.0	A-2-4 (0)	NP	NP	6.6	73.9	3.9	15.6	0	100	97	21	--	--
SS-126	25+87	-Y1RPA-	8 RT	13.5 - 15.0	A-7-6 (26)	56	31	10.5	11.0	24.3	54.2	0	100	95	80	--	--
SS-127	25+87	-Y1RPA-	8 RT	23.5 - 25.0	A-3 (0)	NP	NP	55.0	38.4	5.1	1.5	0	98	73	7	--	--
S-114	16+50	-Y1ARPB-	CL	1.5 - 2.5	A-2-6 (1)	28	15	28.1	41.7	7.7	22.5	0	100	88	32	--	--
SS-166	19+87	-Y2-	19 RT	1.1 - 1.5	A-6 (8)	31	17	16.6	22.0	23.6	37.8	0	100	90	65	--	--
SS-167	19+87	-Y2-	19 RT	8.6 - 10.1	A-6 (2)	36	21	16.4	49.5	8.6	25.3	0	100	96	36	--	--
SS-168	19+87	-Y2-	19 RT	13.6 - 15.1	A-2-4 (0)	NP	NP	7.9	77.4	3.1	11.6	0	100	99	15	--	--
SS-169	19+87	-Y2-	19 RT	18.6 - 20.1	A-2-4 (0)	NP	NP	53.8	27.9	9.3	9.0	0	97	66	20	--	--
SS-170	19+87	-Y2-	19 RT	23.6 - 25.1	A-2-4 (0)	NP	NP	47.4	38.2	8.8	5.5	0	100	85	16	--	--
SS-171	22+53	-Y2-	57 RT	3.3 - 4.8	A-4 (0)	19	4	30.0	29.4	22.2	18.4	0	100	82	45	--	4.2
SS-172	24+79	-Y2-	32 LT	0.0 - 1.5	A-4 (0)	17	5	21.1	30.9	27.7	20.3	0	100	89	53	--	--
SS-173	24+79	-Y2-	32 LT	8.6 - 10.1	A-2-6 (0)	24	11	50.9	26.3	6.7	16.2	0	99	66	25	--	--
SS-174	24+79	-Y2-	32 LT	18.6 - 20.1	A-2-4 (0)	NP	NP	37.9	43.2	5.7	13.3	0	100	81	20	--	--
SS-175	24+79	-Y2-	32 LT	23.6 - 25.1	A-2-4 (0)	NP	NP	63.6	26.9	5.3	4.1	0	98	61	10	--	--
SS-176	24+79	-Y2-	32 LT	33.6 - 35.1	A-3 (0)	NP	NP	62.0	9.7	2.8	25.5	1	98	84	5	--	--
SS-321	24+79	-Y2-	32 LT	38.6 - 40.1	A-2-6 (1)	30	16	62.0	9.7	2.8	25.5	0	100	63	30	--	--
SS-177	24+79	-Y2-	32 LT	43.6 - 45.1	A-2-4 (0)	NP	NP	52.0	31.9	3.1	12.9	0	99	76	17	--	--
SS-178	33+84	-Y2-	59 RT	0.0 - 1.5	A-2-4 (0)	19	6	30.1	39.7	12.1	18.1	0	100	85	34	--	--
SS-179	33+84	-Y2-	59 RT	3.5 - 5.0	A-6 (2)	35	17	35.0	31.0	8.8	25.3	0	100	82	38	--	--
SS-180	33+84	-Y2-	59 RT	13.5 - 15.0	A-4 (1)	25	9	14.5	43.6	23.7	18.3	0	100	95	47	--	--
SS-181	33+84	-Y2-	59 RT	23.5 - 25.0	A-3 (0)	NP	NP	84.9	8.0	2.2	4.9	0	97	31	8	--	--

NP - NON-PLASTIC

  
Certified Lab Technician Signature

Certification Number

### LABORATORY TESTING SUMMARY

PROJECT NUMBER: 47533.1.2

TIP: I-5987A

COUNTY: ROBESON

DESCRIPTION: I-95 IMPROVEMENTS FROM SOUTH OF US 301 (EXIT 22) TO NORTH OF SR 1758 (McDUFFIE CROSSING RD.)

Sample No.	Station	Alignment	Offset (feet)	Depth Interval (feet)	AASHTO Class.	L.L.	P.I.	% by Weight				% Retained #4 Sieve	% Passing (sieves)			% Moisture	% Organic
								Coarse Sand	Fine Sand	Silt	Clay		#10	#40	#200		
SS-182	33+84	-Y2-	59 RT	33.5 - 35.0	A-7-6 (33)	55	31	2.0	3.8	58.3	35.9	0	100	99	95	--	--
SS-183	33+84	-Y2-	59 RT	43.5 - 45.0	A-4 (0)	NP	NP	2.4	64.5	11.9	21.2	0	100	99	41	--	--
SS-184	39+83	-Y2-	25 LT	1.3 - 1.5	A-6 (5)	33	18	27.7	28.9	12.7	30.7	0	100	82	47	--	--
SS-185	39+83	-Y2-	25 LT	8.5 - 10	A-7-6 (4)	42	27	24.3	42.2	6.1	27.4	0	100	92	35	--	--
SS-133	18+16	-Y3-	11 RT	1.0 - 4.0	A-6 (5)	37	18	36.1	19.8	13.4	30.7	0	100	77	47	--	--
SS-199	35+15	-Y3-	11 RT	0.0 - 1.5	A-2-4 (0)	25	10	68.0	15.0	4.9	12.1	0	96	53	18	--	--
SS-200	35+15	-Y3-	10 RT	3.5 - 5.0	A-2-4 (0)	21	7	54.4	23.8	8.4	13.3	1	98	65	24	--	--
SS-201	35+15	-Y3-	10 RT	13.5 - 15.0	A-2-6 (2)	37	22	46.1	25.0	6.8	22.1	0	98	72	32	--	--
SS-202	35+15	-Y3-	10 RT	18.5 - 20.0	A-2-4 (0)	NP	NP	75.5	12.1	3.3	9.1	0	98	43	13	--	--
SS-203	35+15	-Y3-	10 RT	28.5 - 30	A-3 (0)	NP	NP	44.0	49.6	2.0	4.3	0	100	86	7	--	--
SS-204	35+15	-Y3-	10 RT	33.5 - 35.0	A-2-4 (0)	NP	NP	20.8	60.1	3.5	15.6	0	100	96	20	--	--
SS-205	35+15	-Y3-	10 RT	38.5 - 40.0	A-3 (0)	NP	NP	66.6	28.6	1.0	3.8	0	100	61	6	--	--
SS-206	35+15	-Y3-	10 RT	43.5 - 45.0	A-3 (0)	NP	NP	10.9	84.3	2.0	2.8	0	100	100	6	--	--

NP - NON-PLASTIC

  
 Certified Lab Technician Signature

\_\_\_\_\_

Certification Number

NORTH CAROLINA DEPARTMENT OF TRANSPORTATION  
DIVISION OF HIGHWAYS  
GEOTECHNICAL ENGINEERING UNIT  
SUBSURFACE INVESTIGATION

APPENDIX B

TERRACON CPT LOGS

CATLIN CPT LOGS

REFERENCE: I-5987A

PROJECT: 47533.1.1

Prepared in the Office of:

**Terracon**

Consulting Engineers and Scientists  
2401 BRENTWOOD ROAD, SUITE 107  
RALEIGH, NORTH CAROLINA 27604  
NC REGISTERED ENGINEERING FIRM: F-0869  
NC REGISTERED GEOLOGIC FIRM: C-367



# CPT GENERAL NOTES

## DESCRIPTION OF MEASUREMENTS AND CALIBRATIONS

### To be reported per ASTM D5778:

Uncorrected Tip Resistance,  $q_c$   
Measured force acting on the cone divided by the cone's projected area

Corrected Tip Resistance,  $q_t$   
Cone resistance corrected for porewater and net area ratio effects  
 $q_t = q_c + u_2(1 - a)$

Where  $a$  is the net area ratio, a lab calibration of the cone typically between 0.70 and 0.85

Pore Pressure,  $u$   
Pore pressure measured during penetration  
 $u_1$  - sensor on the face of the cone  
 $u_2$  - sensor on the shoulder (more common)

Sleeve Friction,  $f_s$   
Frictional force acting on the sleeve divided by its surface area

Normalized Friction Ratio,  $F_r$   
The ratio as a percentage of  $f_s$  to  $q_t$ , accounting for overburden pressure

### To be reported per ASTM D7400, if collected:

Shear Wave Velocity,  $V_s$   
Measured in a Seismic CPT and provides direct measure of soil stiffness

## DESCRIPTION OF GEOTECHNICAL CORRELATIONS

Normalized Tip Resistance,  $Q_{tn}$   
 $Q_{tn} = ((q_t - \sigma_{vo})/P_a)(P_a/\sigma_{vo})^n$   
 $n = 0.381(l_c) + 0.05(\sigma_{vo}/P_a) - 0.15$

Over Consolidation Ratio, OCR  
OCR (1) =  $0.25(Q_{tn})^{1.25}$   
OCR (2) =  $0.33(Q_{tn})$

Undrained Shear Strength,  $S_u$   
 $S_u = Q_{tn} \times \sigma_{vo}^{1/N_{st}}$   
 $N_{st}$  is a soil-specific factor (shown on  $S_u$  plot)

Sensitivity,  $S_t$   
 $S_t = (q_t - \sigma_{vo}/N_{st}) \times (1/f_s)$

Effective Friction Angle,  $\phi'$   
 $\phi' (1) = \tan^{-1}(0.373[\log(q_t/\sigma_{vo}) + 0.29])$   
 $\phi' (2) = 17.6 + 11[\log(Q_{tn})]$

Unit Weight,  $\gamma$   
 $\gamma = (0.27[\log(F_r)] + 0.36[\log(q_t/\text{atm})] + 1.236) \times \gamma_{water}$   
 $\sigma_{vo}$  is taken as the incremental sum of the unit weights

Small Strain Shear Modulus,  $G_o$   
 $G_o (1) = \rho V_s^2$   
 $G_o (2) = 0.015 \times 10^{(0.55k_c + 1.68)}(q_t - \sigma_{vo})$

Soil Behavior Type Index,  $I_c$   
 $I_c = [(3.47 - \log(Q_{tn}))^2 + (\log(F_r) + 1.22)^2]^{0.5}$

SPT  $N_{60}$   
 $N_{60} = (q_t/\text{atm}) / 10^{(1.1268 - 0.2817I_c)}$

Elastic Modulus,  $E_s$  (assumes  $q_t/q_{t(\text{lim})} \sim 0.3$ , i.e. FS = 3)  
 $E_s (1) = 2.6\psi G_o$  where  $\psi = 0.56 - 0.33\log(Q_{tn}/q_{t(\text{clean sand})})$   
 $E_s (2) = G_o$   
 $E_s (3) = 0.015 \times 10^{(0.55k_c + 1.68)}(q_t - \sigma_{vo})$   
 $E_s (4) = 2.5q_t$

Constrained Modulus,  $M$   
 $M = \alpha_M(q_t - \sigma_{vo})$   
For  $I_c > 2.2$  (fine-grained soils)  
 $\alpha_M = Q_{tn}$  with maximum of 14  
For  $I_c < 2.2$  (coarse-grained soils)  
 $\alpha_M = 0.0188 \times 10^{(0.55k_c + 1.68)}$

Hydraulic Conductivity,  $k$   
For  $1.0 < I_c < 3.27$   $k = 10^{(0.952 - 3.04I_c)}$   
For  $3.27 < I_c < 4.0$   $k = 10^{(-4.52 - 1.37I_c)}$

Relative Density,  $D_r$   
 $D_r = (Q_{tn} / 350)^{0.5} \times 100$

## REPORTED PARAMETERS

CPT logs as provided, at a minimum, report the data as required by ASTM D5778 and ASTM D7400 (if applicable). This minimum data include  $q_t$ ,  $f_s$ , and  $u$ . Other correlated parameters may also be provided. These other correlated parameters are interpretations of the measured data based upon published and reliable references, but they do not necessarily represent the actual values that would be derived from direct testing to determine the various parameters. To this end, more than one correlation to a given parameter may be provided. The following chart illustrates estimates of reliability associated with correlated parameters based upon the literature referenced below.

## RELATIVE RELIABILITY OF CPT CORRELATIONS

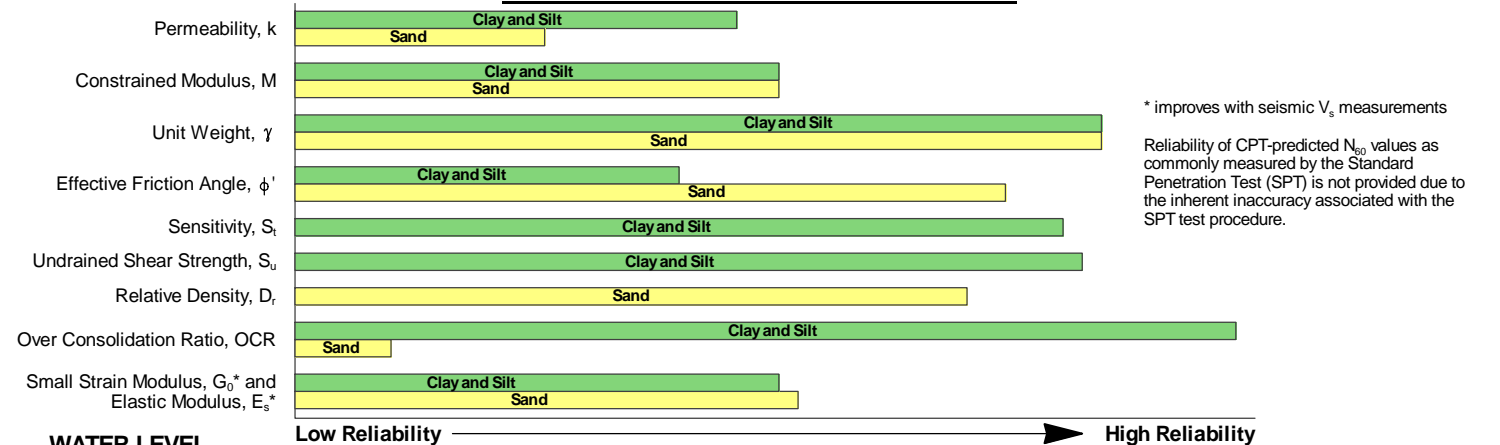

\* improves with seismic  $V_s$  measurements  
Reliability of CPT-predicted  $N_{60}$  values as commonly measured by the Standard Penetration Test (SPT) is not provided due to the inherent inaccuracy associated with the SPT test procedure.

## WATER LEVEL

The groundwater level at the CPT location is used to normalize the measurements for vertical overburden pressures and as a result influences the normalized soil behavior type classification and correlated soil parameters. The water level may either be "measured" or "estimated."

Measured - Depth to water directly measured in the field

Estimated - Depth to water interpolated by the practitioner using pore pressure measurements in coarse grained soils and known site conditions

While groundwater levels displayed as "measured" more accurately represent site conditions at the time of testing than those "estimated," in either case the groundwater should be further defined prior to construction as groundwater level variations will occur over time.

## CONE PENETRATION SOIL BEHAVIOR TYPE

The estimated stratigraphic profiles included in the CPT logs are based on relationships between corrected tip resistance ( $q_t$ ), friction resistance ( $f_s$ ), and porewater pressure ( $u_2$ ). The normalized friction ratio ( $F_r$ ) is used to classify the soil behavior type.

Typically, silts and clays have high  $F_r$  values and generate large excess penetration porewater pressures; sands have lower  $F_r$ 's and do not generate excess penetration porewater pressures. The adjacent graph (Robertson *et al.*) presents the soil behavior type correlation used for the logs. This normalized SBT chart, generally considered the most reliable, does not use pore pressure to determine SBT due to its lack of repeatability in onshore CPTs.

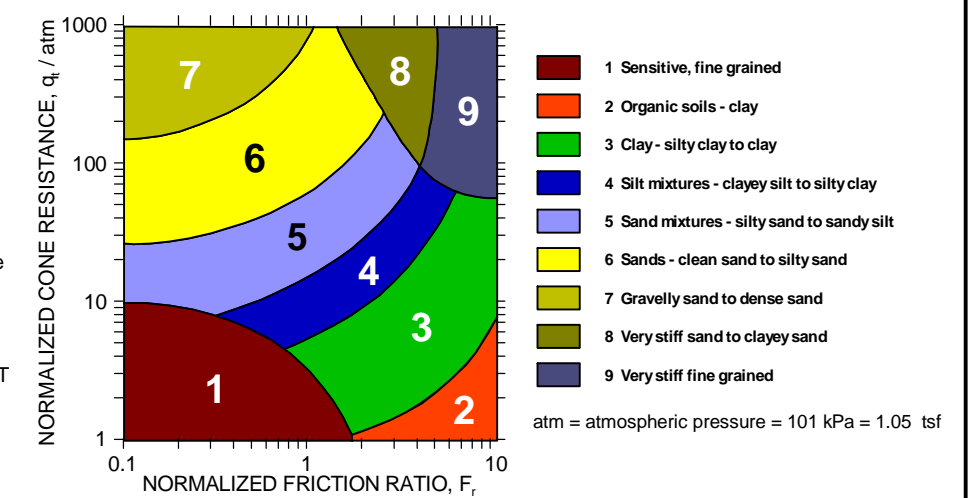

## REFERENCES

- Kulhawy, F.H., Mayne, P.W., (1997). "Manual on Estimating Soil Properties for Foundation Design," Electric Power Research Institute, Palo Alto, CA.
- Mayne, P.W., (2013). "Geotechnical Site Exploration in the Year 2013," Georgia Institute of Technology, Atlanta, GA.
- Robertson, P.K., Cabal, K.L. (2012). "Guide for Cone Penetration Testing for Geotechnical Engineering," Signal Hill, CA.
- Schmertmann, J.H., (1970). "Static Cone to Compute Static Settlement over Sand," *Journal of the Soil Mechanics and Foundations Division*, 96(SM3), 1011-1043.

### CPT LOG NO. Y2-EB2-CPT-1

**PROJECT:** I-5987A - I-95 Mile 21 to 29  
**CLIENT:** NCDOT Geotechnical Engineering Unit  
 Raleigh, NC

**SITE:** I-95  
 Robeson County, NC

**TEST LOCATION:**

Northing: 345984  
 Easting: 2000659

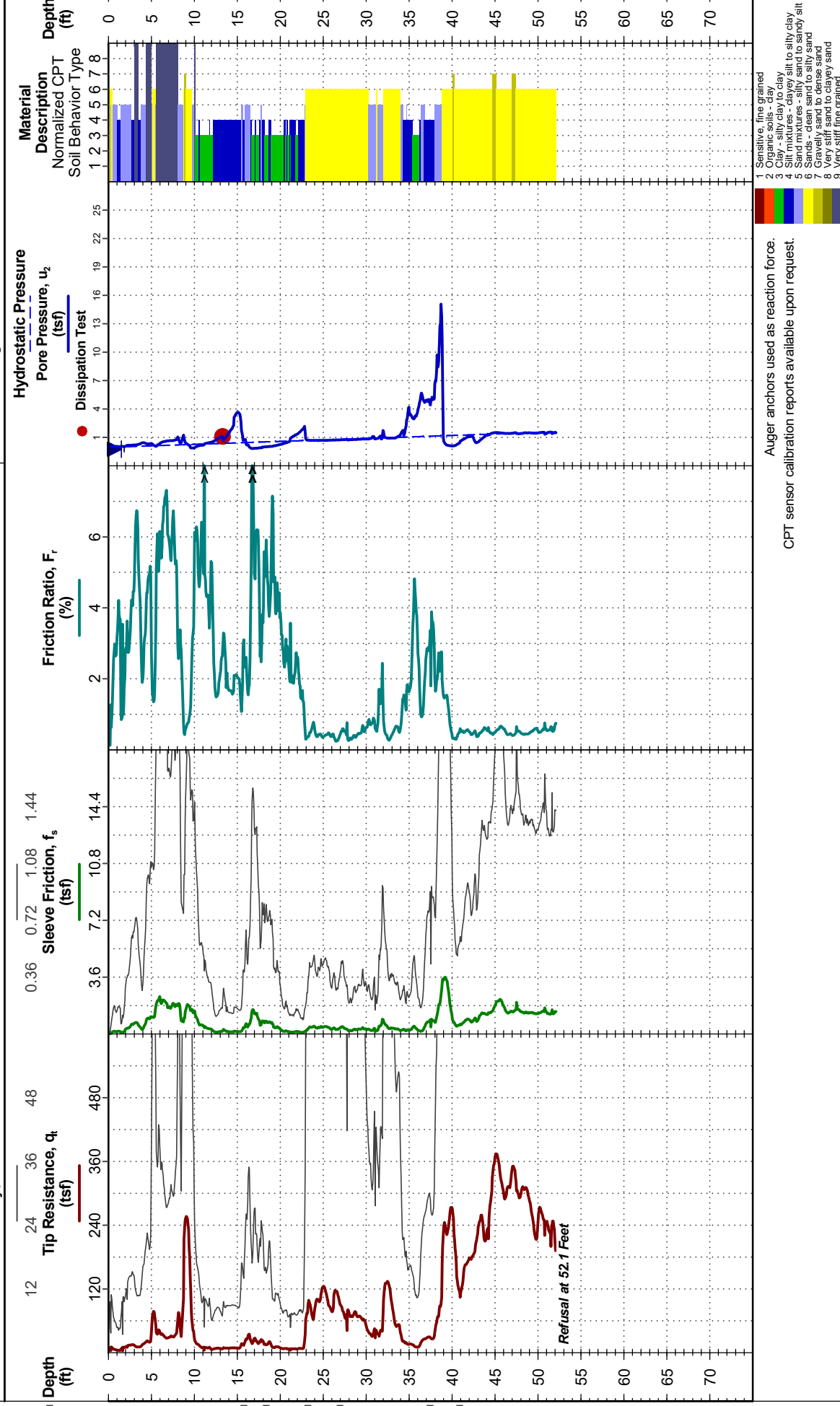

**WATER LEVEL OBSERVATION**  
 1.5 ft measured water depth (used in normalizations and correlations)

Probe no. 5311 with net area ratio of .874  
 U2 pore pressure transducer location  
 Manufactured by Geotech A.B.; calibrated 1/7/2020  
 Tip and sleeve areas of 10 cm<sup>2</sup> and 150 cm<sup>2</sup>  
 Ring friction reducer with O.D. of 1.875 in

**Terracon**  
 1450 Fifth St W  
 North Charleston, SC

CPT Started: 2/23/2021  
 Rig: Geoprobe 477  
 Project No.: 47533.1.1

CPT Completed: 2/23/2021

Operator: BR

THIS BORING LOG IS NOT VALID IF SEPARATED FROM ORIGINAL REPORT. NCDOT\_CPT\_REPORT\_15987\_GEO\_RDWY\_BH\_TERRACON\_CPT.GPJ TERRACON DATE\TEMPLATE.GDT 6/30/21

### CPT LOG NO. Y2-EB1-CPT-2

**PROJECT:** I-5987A - I-95 Mile 21 to 29  
**CLIENT:** NCDOT Geotechnical Engineering Unit  
 Raleigh, NC

**SITE:** I-95  
 Robeson County, NC

**TEST LOCATION:**

Northing: 345962  
 Easting: 2000405

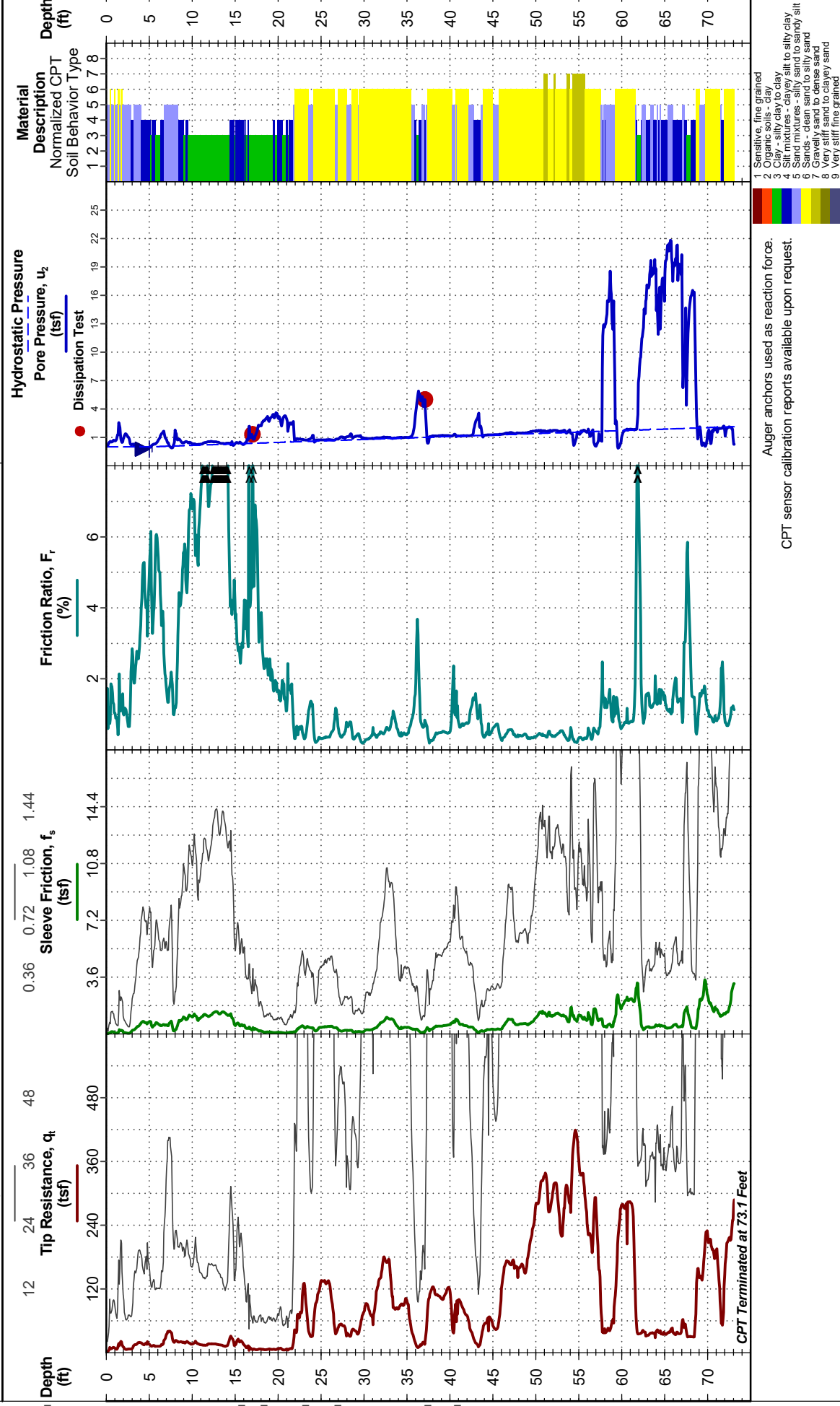

**WATER LEVEL OBSERVATION**  
 5 ft measured water depth (used in normalizations and correlations)

Probe no. 5311 with net area ratio of .874  
 U2 pore pressure transducer location  
 Manufactured by Geotech A.B.; calibrated 1/7/2020  
 Tip and sleeve areas of 10 cm<sup>2</sup> and 150 cm<sup>2</sup>  
 Ring friction reducer with O.D. of 1.875 in

**Terracon**  
 1450 Fifth St W  
 North Charleston, SC

CPT Started: 2/26/2021  
 Rig: Geoprobe 477  
 Project No.: 47533.1.1

CPT Completed: 2/26/2021

Operator: BR

THIS BORING LOG IS NOT VALID IF SEPARATED FROM ORIGINAL REPORT. NCDOT\_CPT\_REPORT\_15987\_GEO\_RDWY\_BH\_TERRACON\_CPT.GPJ TERRACON DATE\TEMPLATE.GDT 6/30/21

### CPT LOG NO. Y1A-RPBCPT3

**PROJECT:** I-5987A - I-95 Mile 21 to 29

**CLIENT:** NCDOT Geotechnical Engineering Unit  
Raleigh, NC

**TEST LOCATION:**

**SITE:** I-95  
Robeson County, NC

Northing: 352971  
Easting: 2000577

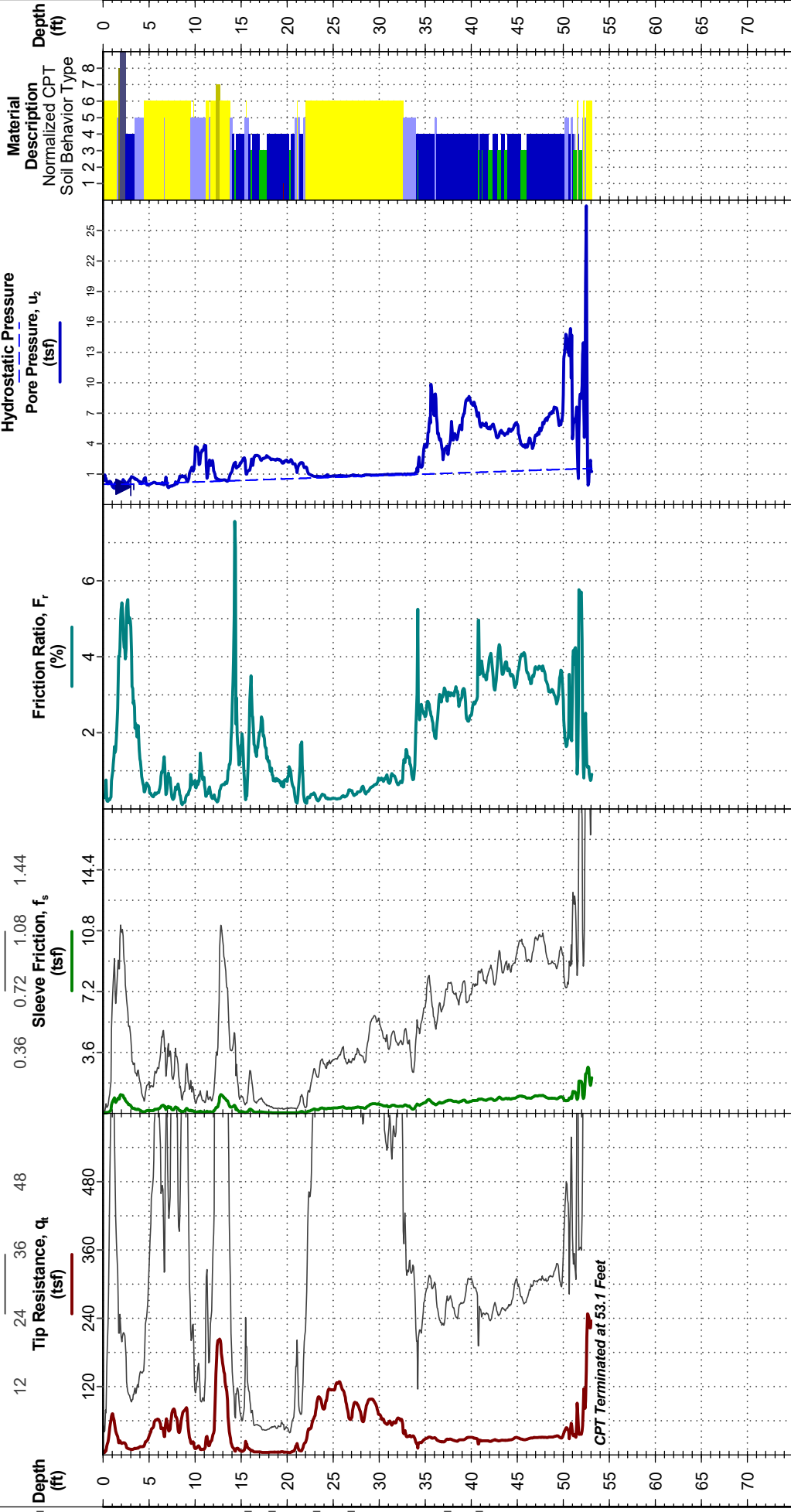

Auger anchors used as reaction force.  
CPT sensor calibration reports available upon request.



Probe no. 5311 with net area ratio of .874  
U2 pore pressure transducer location  
Manufactured by Geotech A.B.; calibrated 1/7/2020  
Tip and sleeve areas of 10 cm<sup>2</sup> and 150 cm<sup>2</sup>  
Ring friction reducer with O.D. of 1.875 in

**WATER LEVEL OBSERVATION**  
3 ft measured water depth  
(used in normalizations and correlations)

CPT Started: 2/25/2021  
CPT Completed: 2/25/2021  
Rig: Geoprobe 477  
Operator: BR  
Project No.: 47533.1.1

### CPT LOG NO. Y1A-CPT-4

**PROJECT:** I-5987A - I-95 Mile 21 to 29

**CLIENT:** NCDOT Geotechnical Engineering Unit  
Raleigh, NC

**TEST LOCATION:**

**SITE:** I-95  
Robeson County, NC

Northing: 353320  
Easting: 2000251

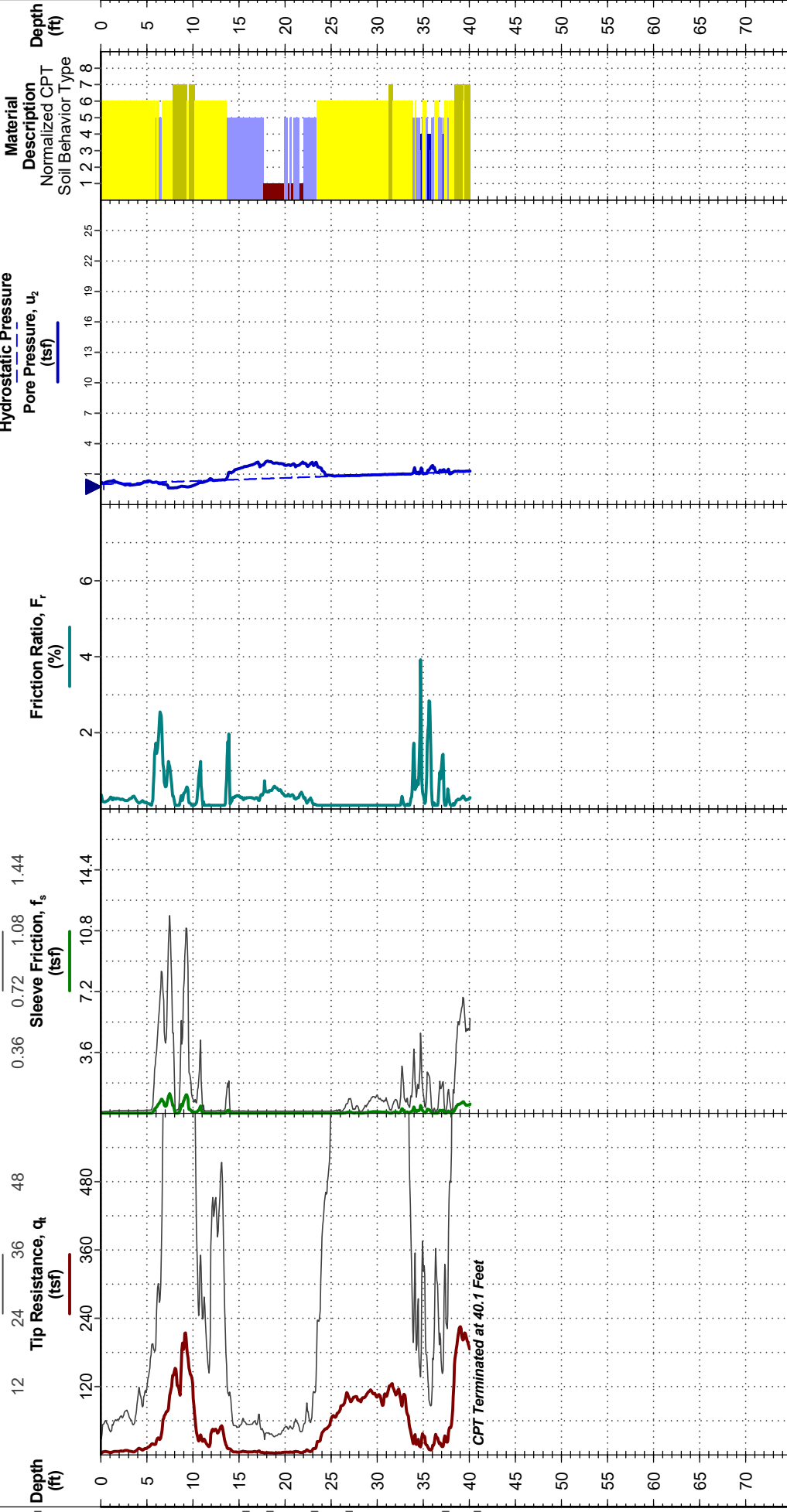

Auger anchors used as reaction force.  
CPT sensor calibration reports available upon request.



Probe no. 5311 with net area ratio of .874  
U2 pore pressure transducer location  
Manufactured by Geotech A.B.; calibrated 1/7/2020  
Tip and sleeve areas of 10 cm<sup>2</sup> and 150 cm<sup>2</sup>  
Ring friction reducer with O.D. of 1.875 in

**WATER LEVEL OBSERVATION**  
0 ft measured water depth  
(used in normalizations and correlations)

CPT Started: 2/25/2021  
CPT Completed: 2/25/2021  
Rig: Geoprobe 477  
Operator: BR  
Project No.: 47533.1.1

CPT LOG NO. Y1A-EB1-CPT5

PROJECT: I-5987A - I-95 Mile 21 to 29  
 CLIENT: NCDOT Geotechnical Engineering Unit  
 Raleigh, NC

SITE: I-95  
 Robeson County, NC

TEST LOCATION:

Northing: 353320  
 Easting: 2000251

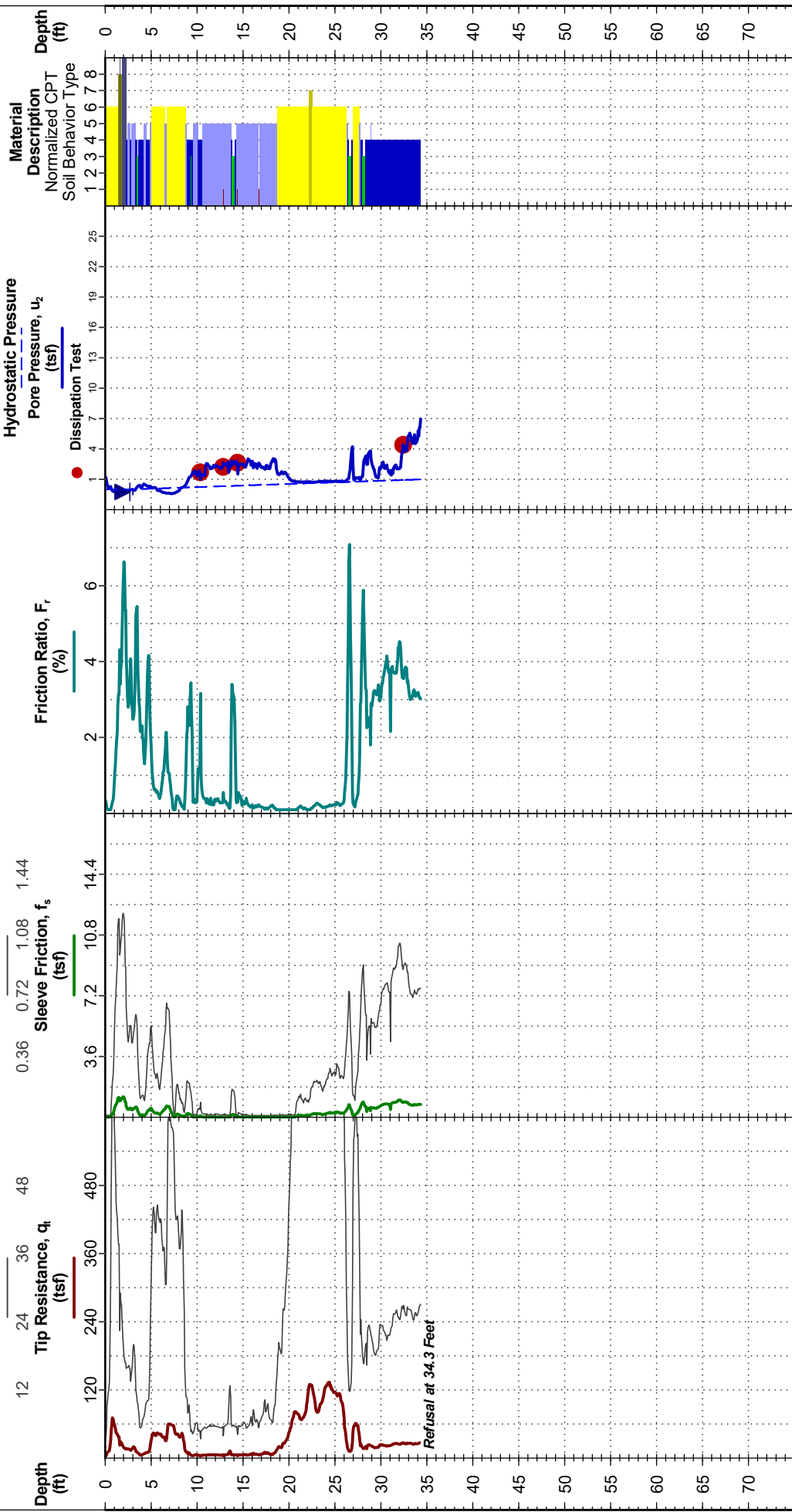

Auger anchors used as reaction force.  
 CPT sensor calibration reports available upon request.



Probe no. 5311 with net area ratio of .874  
 U2 pore pressure transducer location  
 Manufactured by Geotech A.B.; calibrated 1/7/2020  
 Tip and sleeve areas of 10 cm<sup>2</sup> and 150 cm<sup>2</sup>  
 Ring friction reducer with O.D. of 1.875 in

WATER LEVEL OBSERVATION  
 2.7 ft measured water depth  
 (used in normalizations and correlations)

CPT Started: 2/24/2021  
 Rig: Geoprobe 477  
 Project No.: 47533.1.1

CPT Completed: 2/24/2021

Operator: BR

THIS BORING LOG IS NOT VALID IF SEPARATED FROM ORIGINAL REPORT. NCDOT\_CPT\_REPORT\_15987\_GEO\_RDWY\_BH\_TERRACON\_CPT.GPJ TERRACON.CPT.GPJ TERRACON.DATATEMPLATE.GDT 6/30/21

CPT LOG NO. Y1A-EB1CPT5A

PROJECT: I-5987A - I-95 Mile 21 to 29  
 CLIENT: NCDOT Geotechnical Engineering Unit  
 Raleigh, NC

SITE: I-95  
 Robeson County, NC

TEST LOCATION:

Northing: 353620  
 Easting: 2000691

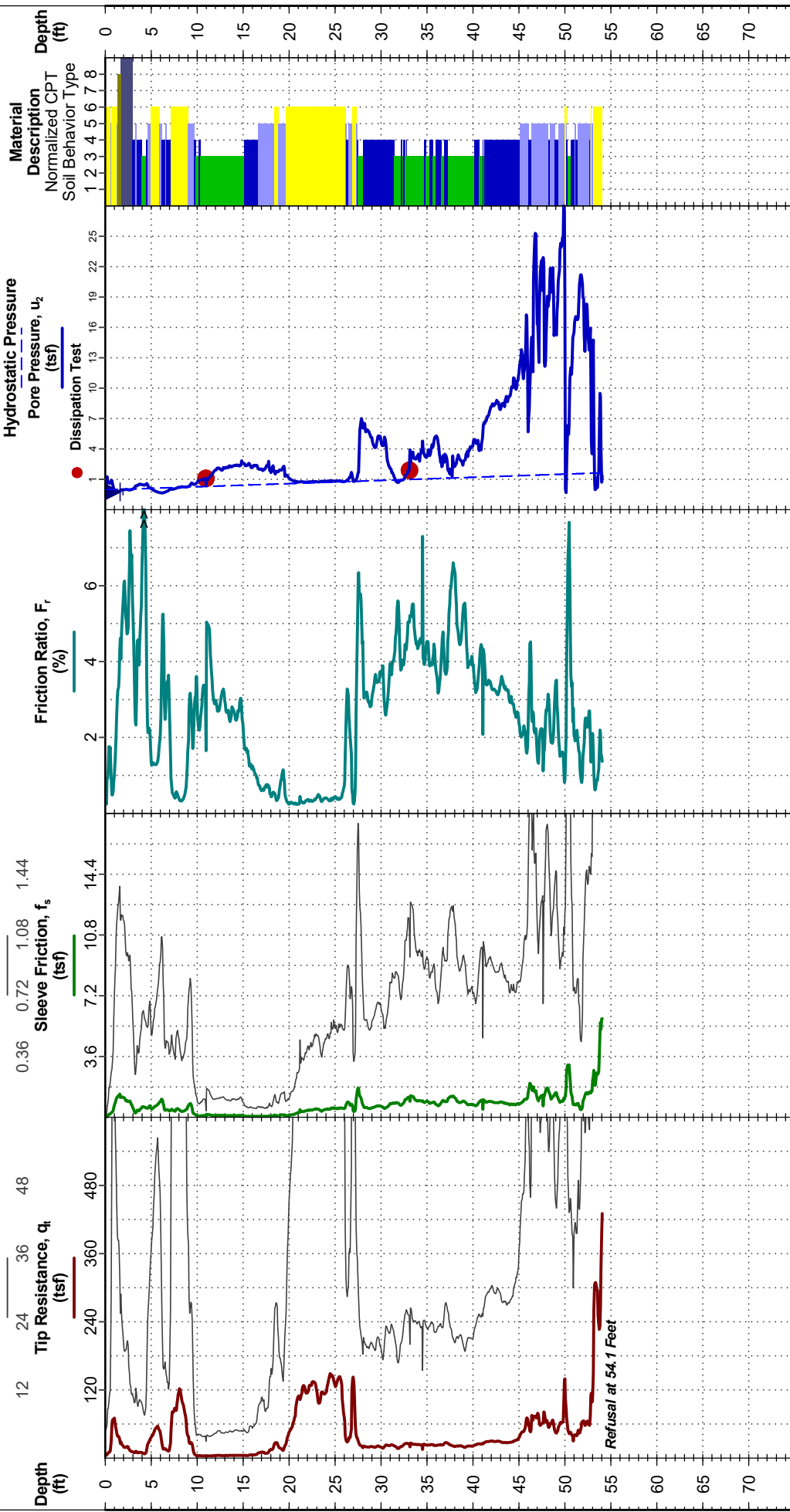

Auger anchors used as reaction force.  
 CPT sensor calibration reports available upon request.



Probe no. 5311 with net area ratio of .874  
 U2 pore pressure transducer location  
 Manufactured by Geotech A.B.; calibrated 1/7/2020  
 Tip and sleeve areas of 10 cm<sup>2</sup> and 150 cm<sup>2</sup>  
 Ring friction reducer with O.D. of 1.875 in

WATER LEVEL OBSERVATION  
 1.6 ft measured water depth  
 (used in normalizations and correlations)

CPT Started: 2/25/2021  
 Rig: Geoprobe 477  
 Project No.: 47533.1.1

CPT Completed: 2/25/2021

Operator: BR

THIS BORING LOG IS NOT VALID IF SEPARATED FROM ORIGINAL REPORT. NCDOT\_CPT\_REPORT\_15987\_GEO\_RDWY\_BH\_TERRACON\_CPT.GPJ TERRACON.CPT.GPJ TERRACON.DATATEMPLATE.GDT 6/30/21

CPT LOG NO. Y1A-EB2-CPT6

PROJECT: I-5987A - I-95 Mile 21 to 29  
CLIENT: NCDOT Geotechnical Engineering Unit  
Raleigh, NC

TEST LOCATION:

Northing: 353599  
Easting: 2000887

SITE: I-95  
Robeson County, NC

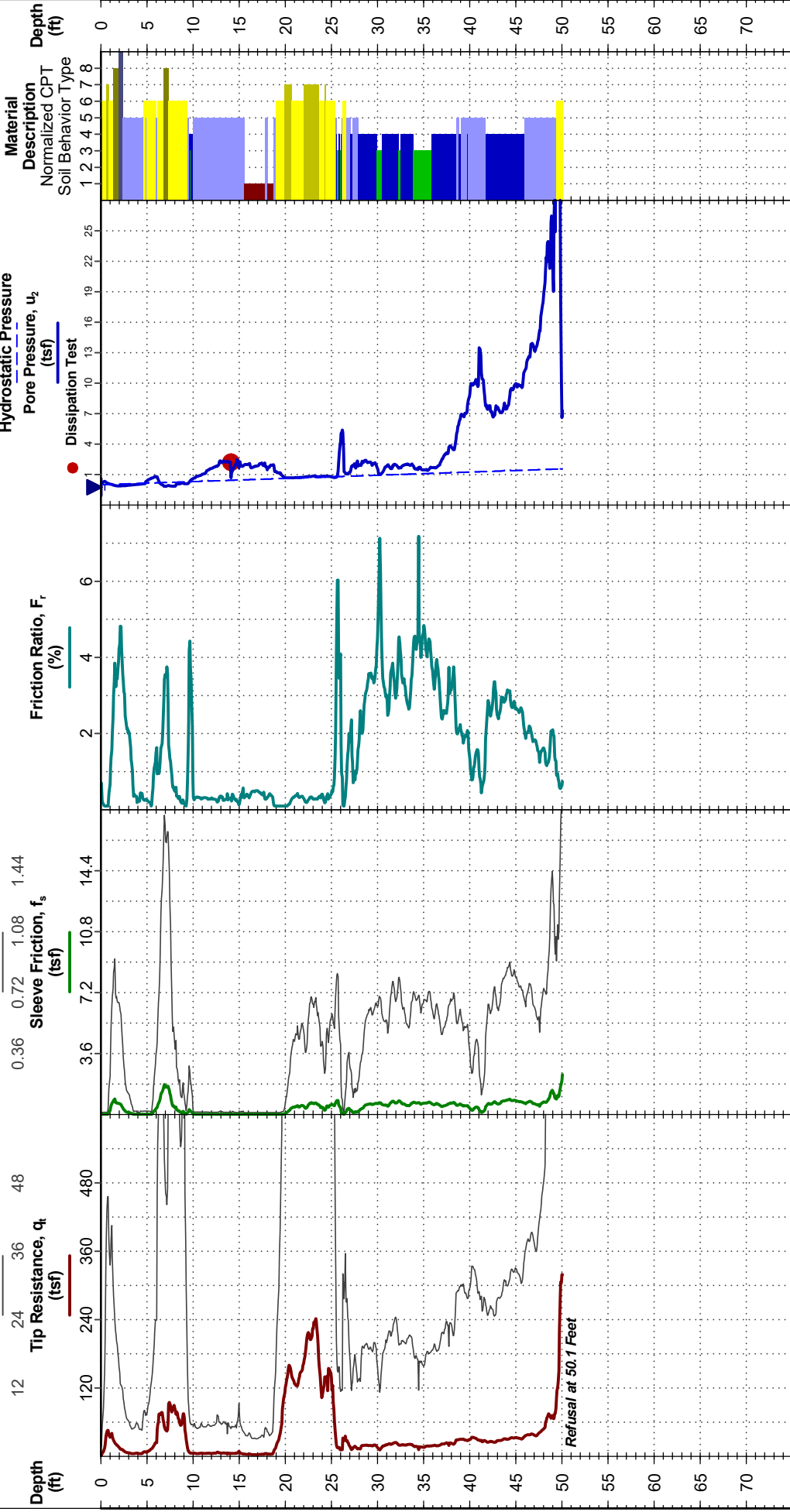

Auger anchors used as reaction force.  
CPT sensor calibration reports available upon request.



Probe no. 5311 with net area ratio of .874  
U2 pore pressure transducer location  
Manufactured by Geotech A.B.; calibrated 1/7/2020  
Tip and sleeve areas of 10 cm<sup>2</sup> and 150 cm<sup>2</sup>  
Ring friction reducer with O.D. of 1.875 in

**WATER LEVEL OBSERVATION**  
0.1 ft measured water depth  
(used in normalizations and correlations)

CPT Started: 2/23/2021  
Rig: Geoprobe 477  
Project No.: 47533.1.1  
CPT Completed: 2/23/2021  
Operator: BR

CPT LOG NO. C3-CPT-7

PROJECT: I-5987A - I-95 Mile 21 to 29  
CLIENT: NCDOT Geotechnical Engineering Unit  
Raleigh, NC

TEST LOCATION:

Northing: 356105  
Easting: 2000724

SITE: I-95  
Robeson County, NC

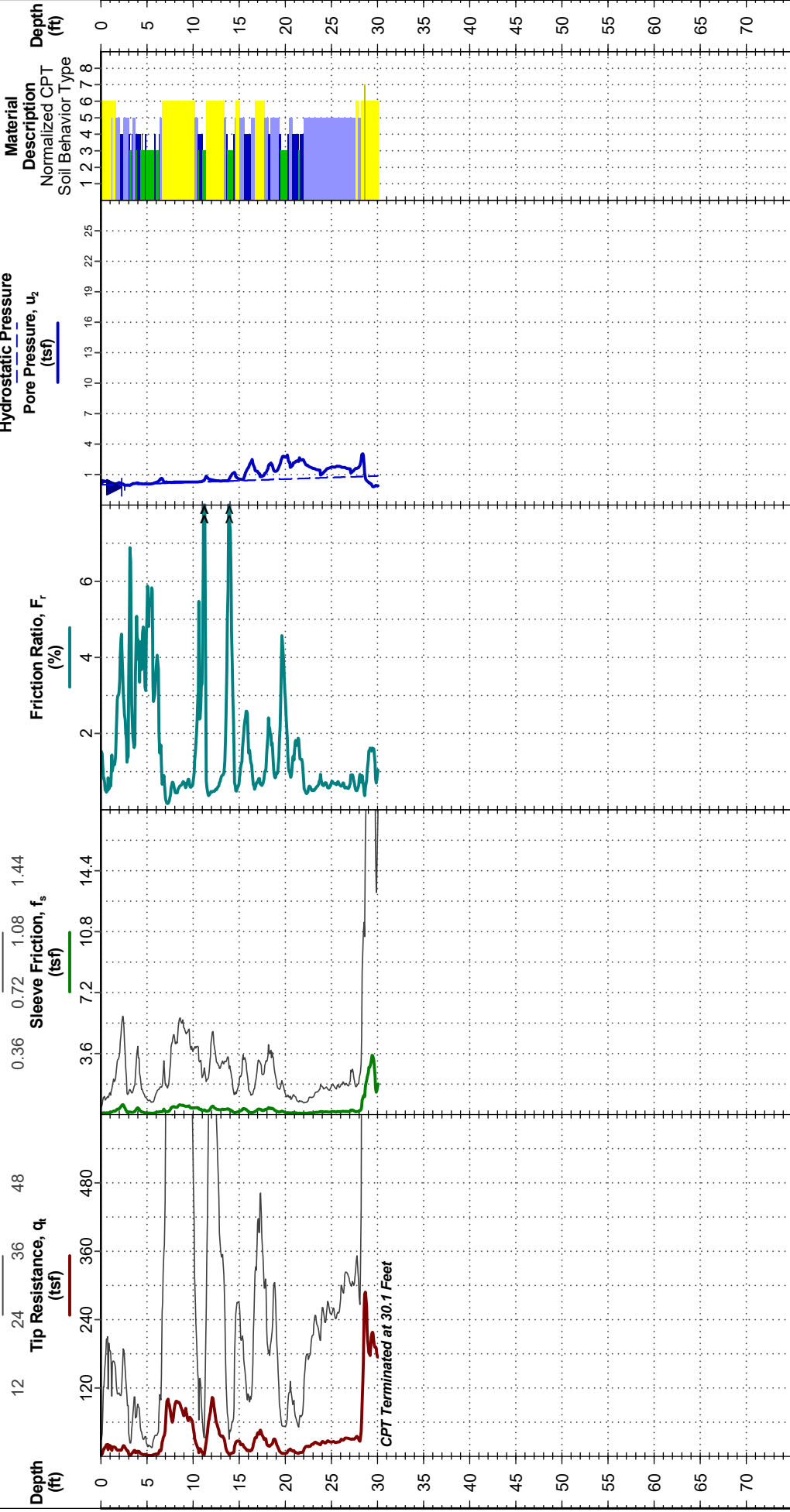

Auger anchors used as reaction force.  
CPT sensor calibration reports available upon request.



Probe no. 5311 with net area ratio of .874  
U2 pore pressure transducer location  
Manufactured by Geotech A.B.; calibrated 1/7/2020  
Tip and sleeve areas of 10 cm<sup>2</sup> and 150 cm<sup>2</sup>  
Ring friction reducer with O.D. of 1.875 in

**WATER LEVEL OBSERVATION**  
2.25 ft measured water depth  
(used in normalizations and correlations)

CPT Started: 2/24/2021  
Rig: Geoprobe 477  
Project No.: 47533.1.1  
CPT Completed: 2/24/2021  
Operator: BR

### CPT LOG NO. C3-CPT8

**PROJECT:** I-5987A - I-95 Mile 21 to 29  
**SITE:** I-95  
 Robeson County, NC

**CLIENT:** NCDOT Geotechnical Engineering Unit  
 Raleigh, NC

**TEST LOCATION:**  
 Northing: 356045  
 Easting: 2000901

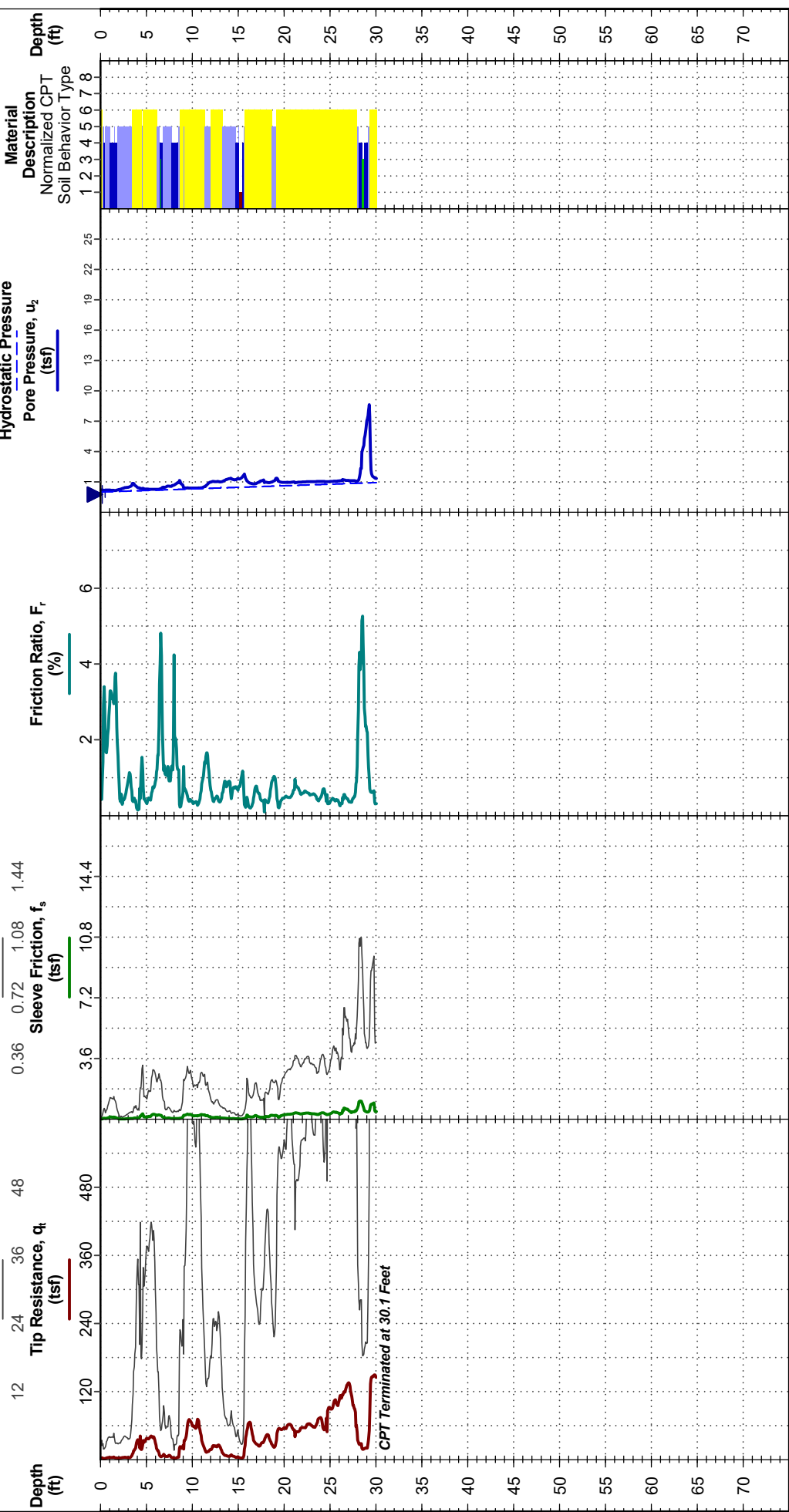

Auger anchors used as reaction force.  
 CPT sensor calibration reports available upon request.

CPT Started: 2/24/2021  
 Rig: Geoprobe 477  
 Project No.: 47533.1.1  
 CPT Completed: 2/24/2021  
 Operator: BR

<b>WATER LEVEL OBSERVATION</b> 0.2 ft measured water depth (used in normalizations and correlations)	
Probe no. 5311 with net area ratio of .874 U2 pore pressure transducer location Manufactured by Geotech A.B.; calibrated 1/7/2020 Tip and sleeve areas of 10 cm <sup>2</sup> and 150 cm <sup>2</sup> Ring friction reducer with O.D. of 1.875 in	<b>Terracon</b> 1450 Fifth St W North Charleston, SC

1 Sensitive, fine grained  
 2 Organic soils - clay  
 3 Silty clay  
 4 Silt mixtures - clayey silt to silty clay  
 5 Sand mixtures - silty sand to sandy silt  
 6 Sands - clean sand to silty sand  
 7 Gravely sand to dense sand  
 8 Silty sand to clayey sand  
 9 Very stiff, fine grained

### CPT LOG NO. C4-CPT-9

**PROJECT:** I-5987A - I-95 Mile 21 to 29  
**SITE:** I-95  
 Robeson County, NC

**CLIENT:** NCDOT Geotechnical Engineering Unit  
 Raleigh, NC

**TEST LOCATION:**  
 Northing: 361483  
 Easting: 2000765

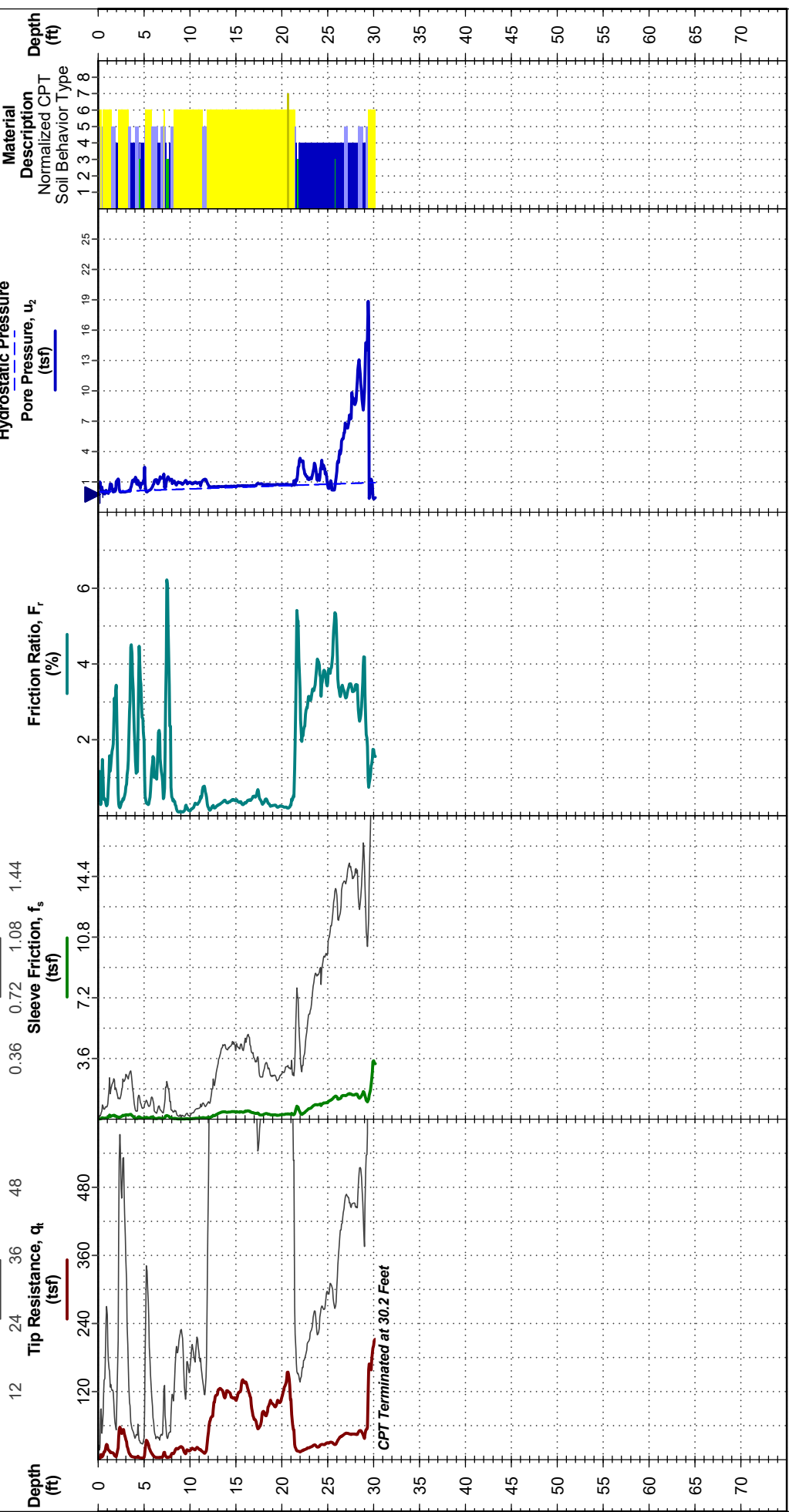

Auger anchors used as reaction force.  
 CPT sensor calibration reports available upon request.

CPT Started: 2/24/2021  
 Rig: Geoprobe 477  
 Project No.: 47533.1.1  
 CPT Completed: 2/24/2021  
 Operator: BR

<b>WATER LEVEL OBSERVATION</b> 0.2 ft measured water depth (used in normalizations and correlations)	
Probe no. 5311 with net area ratio of .874 U2 pore pressure transducer location Manufactured by Geotech A.B.; calibrated 1/7/2020 Tip and sleeve areas of 10 cm <sup>2</sup> and 150 cm <sup>2</sup> Ring friction reducer with O.D. of 1.875 in	<b>Terracon</b> 1450 Fifth St W North Charleston, SC

1 Sensitive, fine grained  
 2 Organic soils - clay  
 3 Silty clay  
 4 Silt mixtures - clayey silt to silty clay  
 5 Sand mixtures - silty sand to sandy silt  
 6 Sands - clean sand to silty sand  
 7 Gravely sand to dense sand  
 8 Silty sand to clayey sand  
 9 Very stiff, fine grained

**CPT LOG NO. Y3-EB1-CPT10**

PROJECT: I-5987A - I-95 Mile 21 to 29

TEST LOCATION:

SITE: I-95  
Robeson County, NC

Northing: 371162  
Easting: 2001014

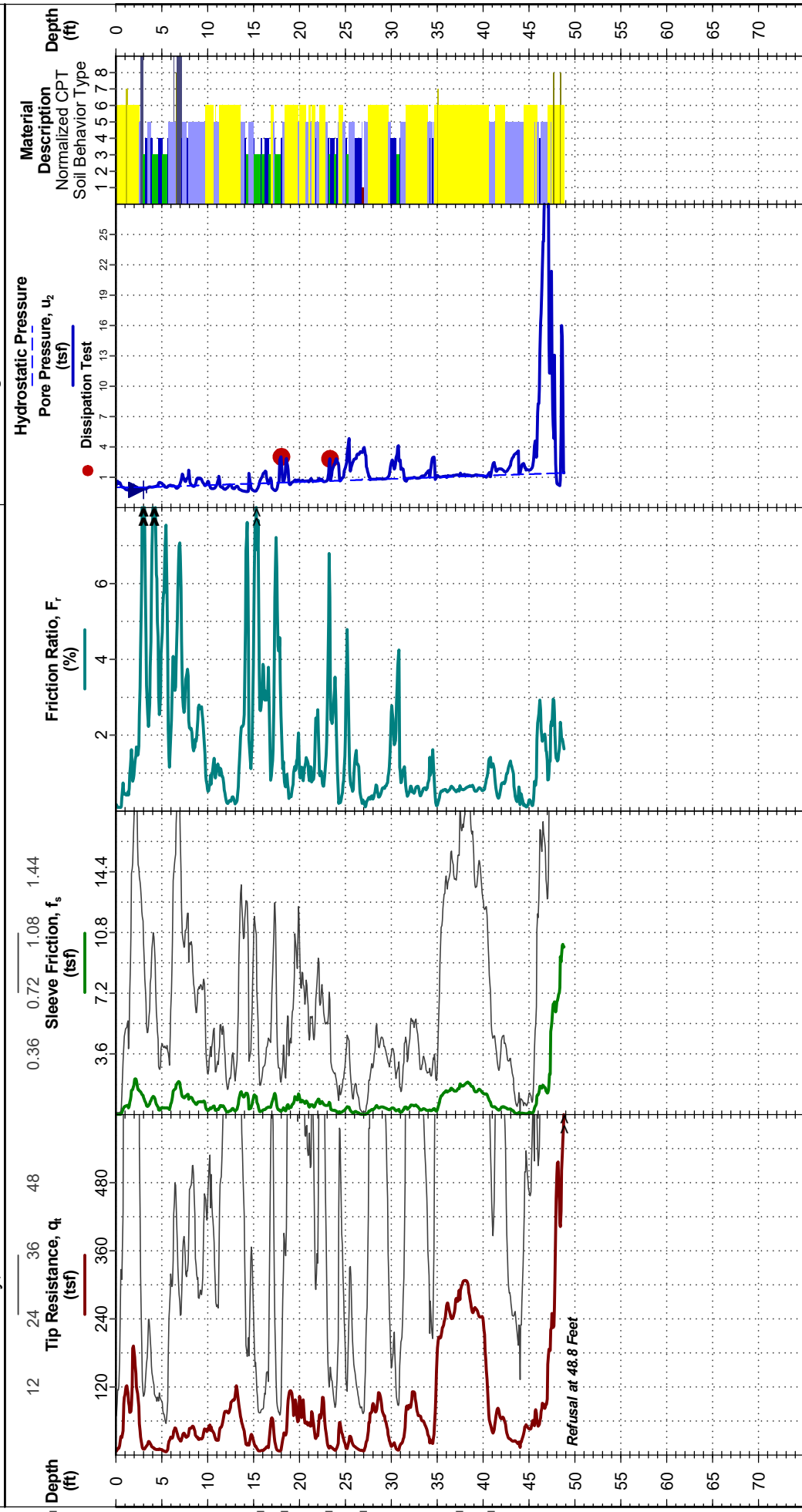

Auger anchors used as reaction force.  
CPT sensor calibration reports available upon request.



Probe no. 5311 with net area ratio of .874  
U2 pore pressure transducer location  
Manufactured by Geotech A.B.; calibrated 1/7/2020  
Tip and sleeve areas of 10 cm<sup>2</sup> and 150 cm<sup>2</sup>  
Ring friction reducer with O.D. of 1.875 in

**WATER LEVEL OBSERVATION**  
3 ft measured water depth  
(used in normalizations and correlations)

CPT Started: 2/24/2021  
Rig: Geoprobe 477  
Project No.: 47533.1.1  
CPT Completed: 2/24/2021  
Operator: BR

**CPT LOG NO. Y3-EB2-CPT11**

PROJECT: I-5987A - I-95 Mile 21 to 29

TEST LOCATION:

SITE: I-95  
Robeson County, NC

Northing: 371427  
Easting: 2001255

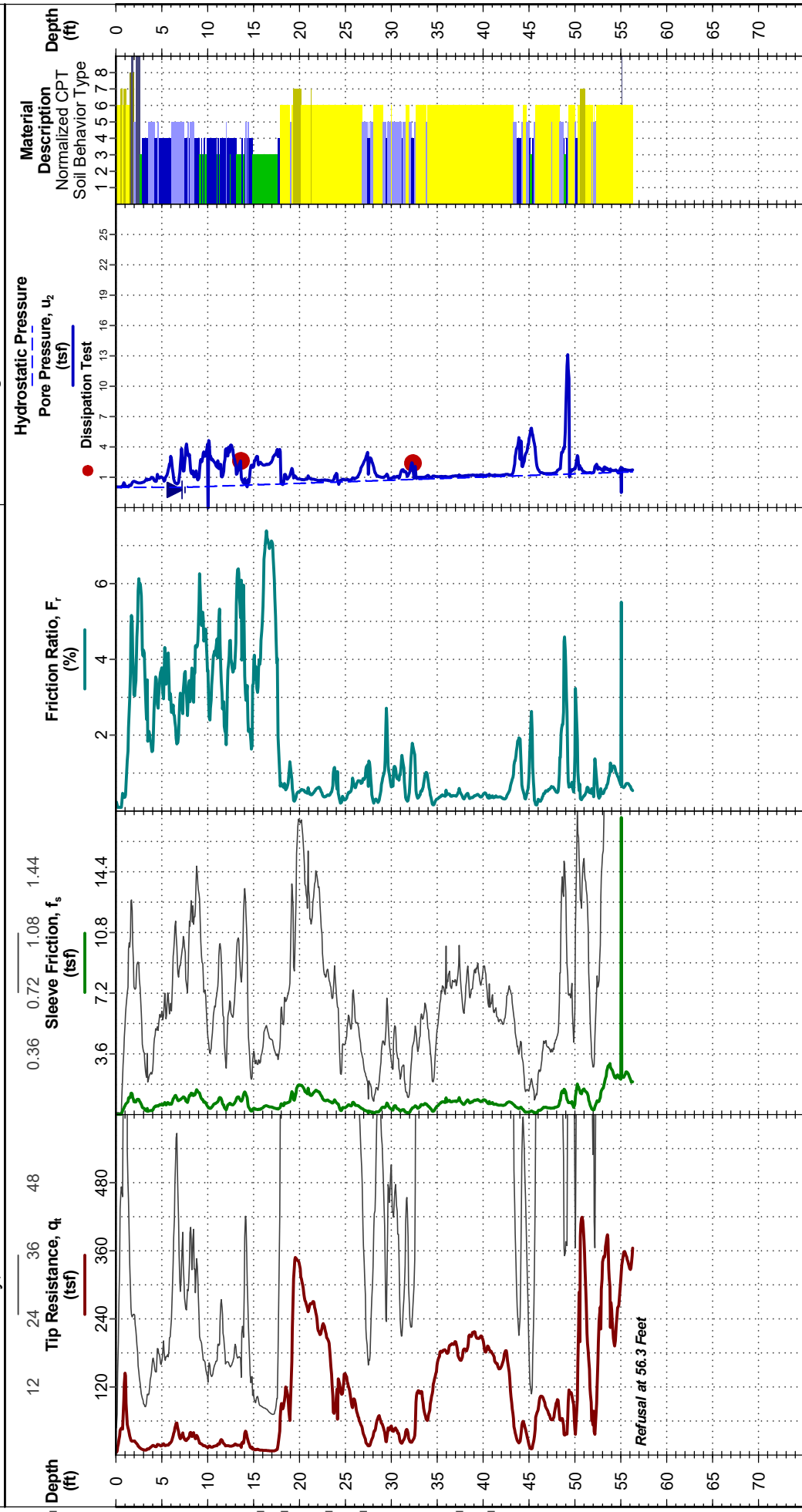

Auger anchors used as reaction force.  
CPT sensor calibration reports available upon request.



Probe no. 5311 with net area ratio of .874  
U2 pore pressure transducer location  
Manufactured by Geotech A.B.; calibrated 1/7/2020  
Tip and sleeve areas of 10 cm<sup>2</sup> and 150 cm<sup>2</sup>  
Ring friction reducer with O.D. of 1.875 in

**WATER LEVEL OBSERVATION**  
7.2 ft measured water depth  
(used in normalizations and correlations)

CPT Started: 2/24/2021  
Rig: Geoprobe 477  
Project No.: 47533.1.1  
CPT Completed: 2/24/2021  
Operator: BR

# CONE PENETROMETER TEST BORING REPORT

WBS: 47533.1.1	TIP: I-5987A	COUNTY: ROBESON/CUMBERLAND	GEOLOGIST: S. HUDSON
SITE DESCRIPTION: I-95 CUMBERLAND/ROBESON COUNTIES FROM US 301 (EXIT 22) TO I-95 BUSINESS/US 301 (EXIT 40)			GROUND WTR (ft)
BORING NO.: L_11200_LT	STATION: 112+00	OFFSET: 90 ft LT	ALIGNMENT: -L-
COLLAR ELEV.: 126.8 ft		TOTAL DEPTH: 9.4 ft	EASTING: 1,998,515

WBS: 47533.1.1	TIP: I-5987A	COUNTY: ROBESON/CUMBERLAND	GEOLOGIST: S. HUDSON
SITE DESCRIPTION: I-95 CUMBERLAND/ROBESON COUNTIES FROM US 301 (EXIT 22) TO I-95 BUSINESS/US 301 (EXIT 40)			GROUND WTR (ft)
BORING NO.: L_11700_LT	STATION: 117+00	OFFSET: 100 ft LT	ALIGNMENT: -L-
COLLAR ELEV.: 128.2 ft		TOTAL DEPTH: 9.4 ft	EASTING: 1,998,636

CPT RIG/MAX. DOWN PRESSURE: CATLIN CPT/DPT-01 / 9 TONS (NO ANCHORS)	CONE TYPE: TYPE 2 PIEZOcone	CONE ID: DSG0867
---	-----------------------------	------------------

CPT RIG/MAX. DOWN PRESSURE: CATLIN CPT/DPT-01 / 9 TONS (NO ANCHORS)	CONE TYPE: TYPE 2 PIEZOcone	CONE ID: DSG0867
---	-----------------------------	------------------

DRILLER: EDDIE SWAIN	OPERATOR: CATLIN	START DATE: 02/04/20	COMP. DATE: 02/04/20	SURF. WATER DEPTH: N/A
----------------------	------------------	----------------------	----------------------	------------------------

DRILLER: EDDIE SWAIN	OPERATOR: CATLIN	START DATE: 02/04/20	COMP. DATE: 02/04/20	SURF. WATER DEPTH: N/A
----------------------	------------------	----------------------	----------------------	------------------------

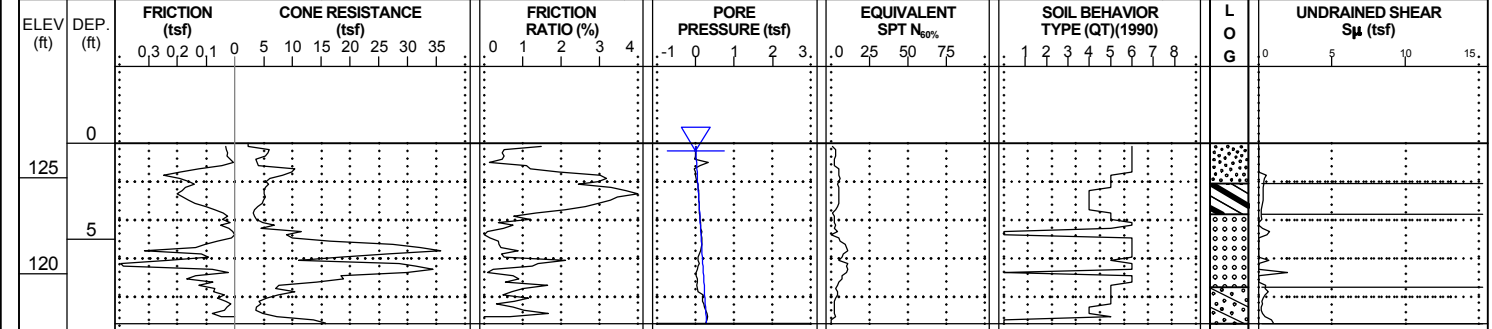

(0 HR. GROUNDWATER ESTIMATED FROM PORE PRESSURE)  
Boring Terminated at Elevation 117.4 ft

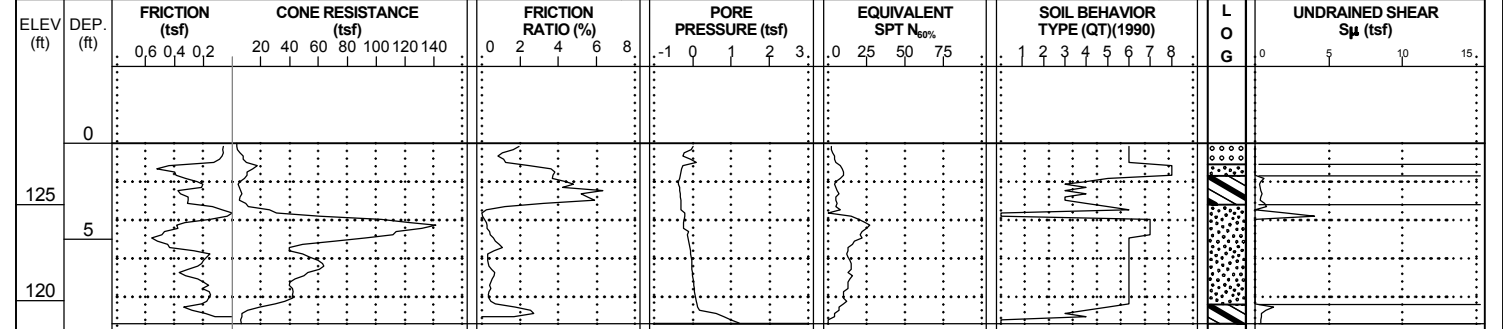

(0 HR. GROUNDWATER ESTIMATED FROM PORE PRESSURE)  
Boring Terminated at Elevation 118.8 ft  
PORE PRESSURE NOT CONDUSIVE TO ESTIMATING GROUND WATER - EST. GROUNDWATER SUSPECT



# CONE PENETROMETER TEST BORING REPORT



<b>WBS:</b> 47533.1.1	<b>TIP:</b> I-5987A	<b>COUNTY:</b> ROBESON/CUMBERLAND	<b>GEOLOGIST:</b> S. HUDSON
<b>SITE DESCRIPTION:</b> I-95 CUMBERLAND/ROBESON COUNTIES FROM US 301 (EXIT 22) TO I-95 BUSINESS/US 301 (EXIT 40)			<b>GROUND WTR (ft)</b>
<b>BORING NO.:</b> L_12200_LT	<b>STATION:</b> 122+00	<b>OFFSET:</b> 105 ft LT	<b>ALIGNMENT:</b> -L-
<b>COLLAR ELEV.:</b> 131.4 ft	<b>TOTAL DEPTH:</b> 9.5 ft	<b>NORTHING:</b> 337,341	<b>EASTING:</b> 1,998,763
<b>CPT RIG/MAX. DOWN PRESSURE:</b> CATLIN CPT/DPT-01 / 9 TONS (NO ANCHORS)		<b>CONE TYPE:</b> TYPE 2 PIEZOCONE	<b>CONE ID:</b> DSG0867
<b>DRILLER:</b> EDDIE SWAIN	<b>OPERATOR:</b> CATLIN	<b>START DATE:</b> 02/04/20	<b>COMP. DATE:</b> 02/04/20
		<b>SURF. WATER DEPTH:</b> N/A	

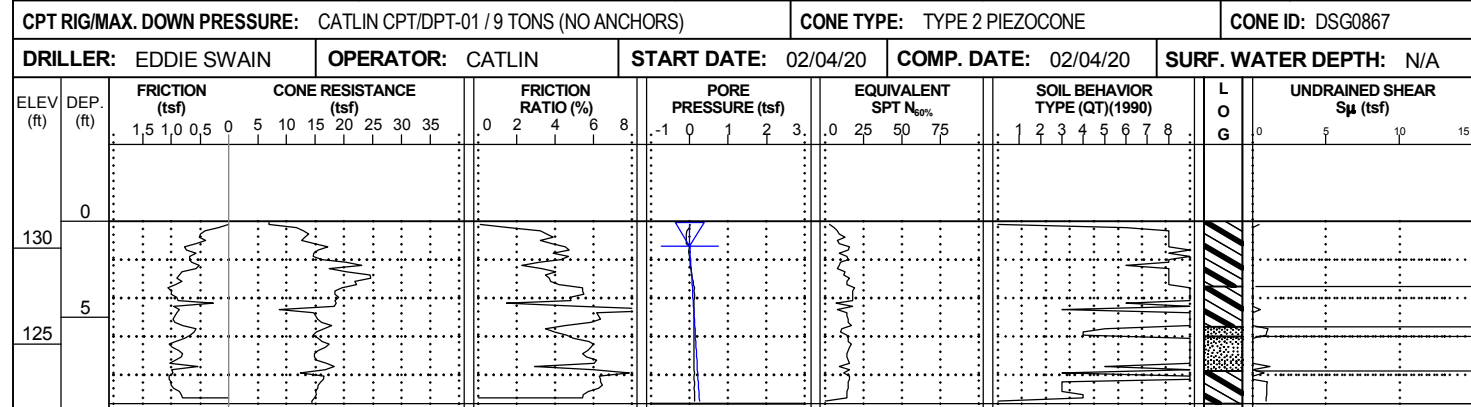

(0 HR. GROUNDWATER ESTIMATED FROM PORE PRESSURE)  
Boring Terminated at Elevation 121.9 ft

<b>WBS:</b> 47533.1.1	<b>TIP:</b> I-5987A	<b>COUNTY:</b> ROBESON/CUMBERLAND	<b>GEOLOGIST:</b> S. HUDSON
<b>SITE DESCRIPTION:</b> I-95 CUMBERLAND/ROBESON COUNTIES FROM US 301 (EXIT 22) TO I-95 BUSINESS/US 301 (EXIT 40)			<b>GROUND WTR (ft)</b>
<b>BORING NO.:</b> L_12700_LT	<b>STATION:</b> 127+00	<b>OFFSET:</b> 103 ft LT	<b>ALIGNMENT:</b> -L-
<b>COLLAR ELEV.:</b> 133.6 ft	<b>TOTAL DEPTH:</b> 12.5 ft	<b>NORTHING:</b> 337,823	<b>EASTING:</b> 1,998,896
<b>CPT RIG/MAX. DOWN PRESSURE:</b> CATLIN CPT/DPT-01 / 9 TONS (NO ANCHORS)		<b>CONE TYPE:</b> TYPE 2 PIEZOCONE	<b>CONE ID:</b> DSG0867
<b>DRILLER:</b> EDDIE SWAIN	<b>OPERATOR:</b> CATLIN	<b>START DATE:</b> 02/04/20	<b>COMP. DATE:</b> 02/04/20
		<b>SURF. WATER DEPTH:</b> N/A	

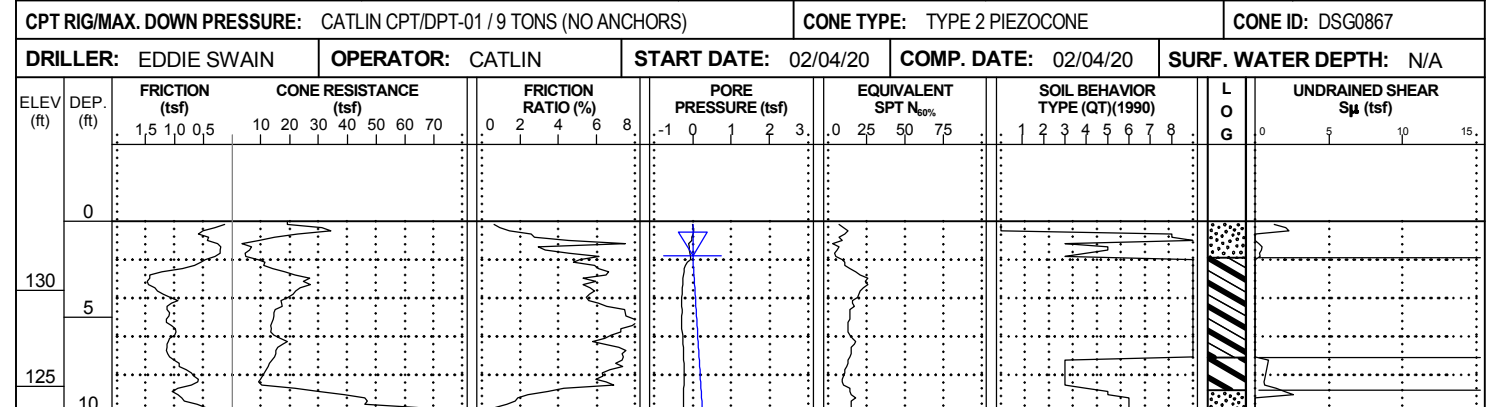

(0 HR. GROUNDWATER ESTIMATED FROM PORE PRESSURE)  
Boring Terminated at Elevation 121.1 ft

NCDOT CPT DOUBLE (PORTRAIT) NO-LITH 15987\_GEO\_RDWY\_CATLIN\_GTM-DRILLED\_REVISED.GPJ NCDOT\_CATLIN.GDT 07/30/20

# CONE PENETROMETER TEST BORING REPORT



<b>WBS:</b> 47533.1.1	<b>TIP:</b> I-5987A	<b>COUNTY:</b> ROBESON/CUMBERLAND	<b>GEOLOGIST:</b> S. HUDSON
<b>SITE DESCRIPTION:</b> I-95 CUMBERLAND/ROBESON COUNTIES FROM US 301 (EXIT 22) TO I-95 BUSINESS/US 301 (EXIT 40)			<b>GROUND WTR (ft)</b>
<b>BORING NO.:</b> L_13200_LT	<b>STATION:</b> 132+00	<b>OFFSET:</b> 105 ft LT	<b>ALIGNMENT:</b> -L-
<b>COLLAR ELEV.:</b> 134.1 ft	<b>TOTAL DEPTH:</b> 12.5 ft	<b>NORTHING:</b> 338,306	<b>EASTING:</b> 1,999,025
<b>CPT RIG/MAX. DOWN PRESSURE:</b> CATLIN CPT/DPT-01 / 9 TONS (NO ANCHORS)		<b>CONE TYPE:</b> TYPE 2 PIEZOCONE	<b>CONE ID:</b> DSG0867
<b>DRILLER:</b> EDDIE SWAIN	<b>OPERATOR:</b> CATLIN	<b>START DATE:</b> 02/04/20	<b>COMP. DATE:</b> 02/04/20
<b>EST. 0 HR.</b> 2.8		<b>24 HR.</b> N/A	

<b>WBS:</b> 47533.1.1	<b>TIP:</b> I-5987A	<b>COUNTY:</b> ROBESON/CUMBERLAND	<b>GEOLOGIST:</b> S. HUDSON
<b>SITE DESCRIPTION:</b> I-95 CUMBERLAND/ROBESON COUNTIES FROM US 301 (EXIT 22) TO I-95 BUSINESS/US 301 (EXIT 40)			<b>GROUND WTR (ft)</b>
<b>BORING NO.:</b> L_13700_LT	<b>STATION:</b> 137+00	<b>OFFSET:</b> 105 ft LT	<b>ALIGNMENT:</b> -L-
<b>COLLAR ELEV.:</b> 135.3 ft	<b>TOTAL DEPTH:</b> 12.5 ft	<b>NORTHING:</b> 338,788	<b>EASTING:</b> 1,999,156
<b>CPT RIG/MAX. DOWN PRESSURE:</b> CATLIN CPT/DPT-01 / 9 TONS (NO ANCHORS)		<b>CONE TYPE:</b> TYPE 2 PIEZOCONE	<b>CONE ID:</b> DSG0867
<b>DRILLER:</b> EDDIE SWAIN	<b>OPERATOR:</b> CATLIN	<b>START DATE:</b> 02/03/20	<b>COMP. DATE:</b> 02/03/20
<b>EST. 0 HR.</b> 1.2		<b>24 HR.</b> N/A	

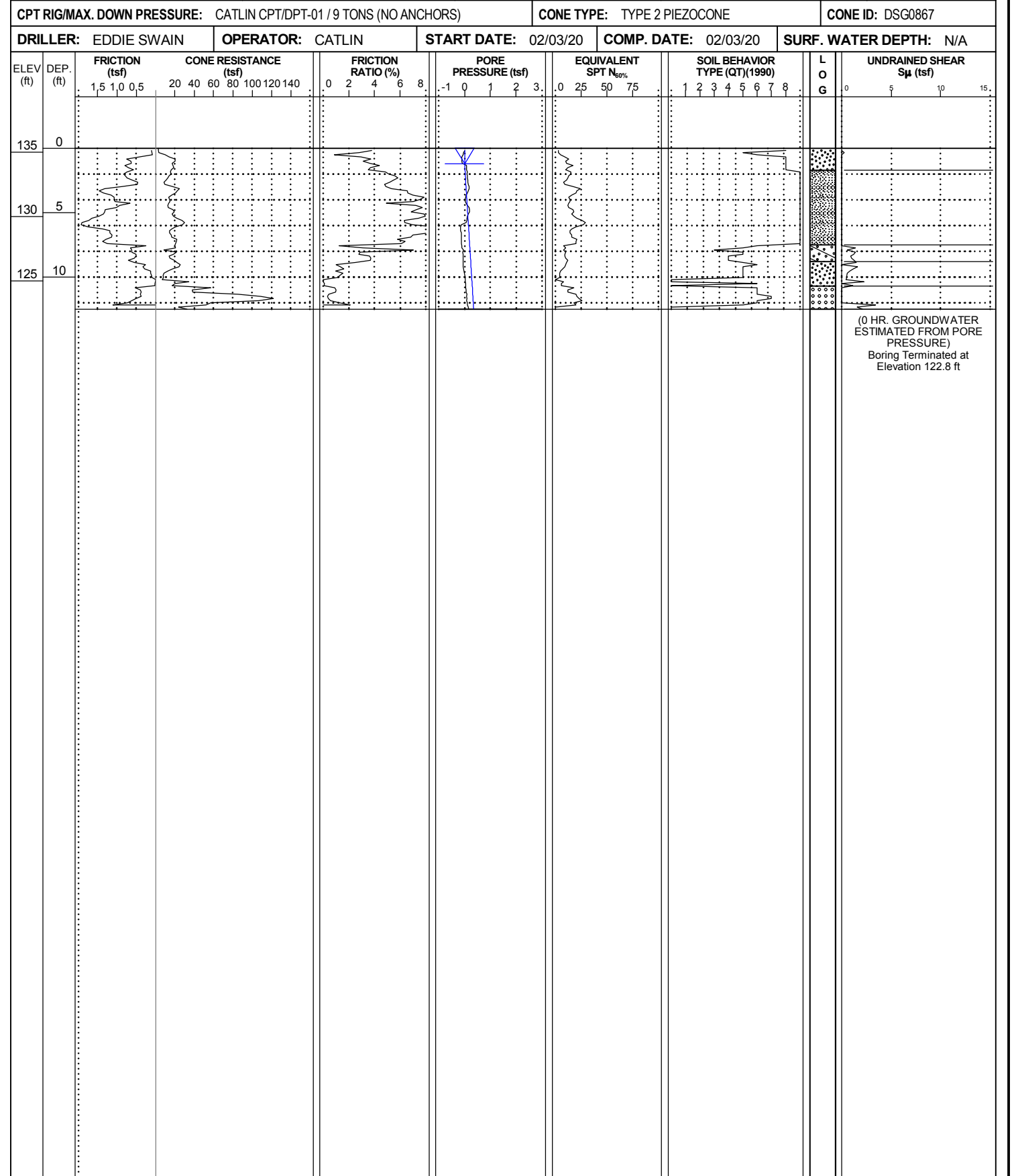
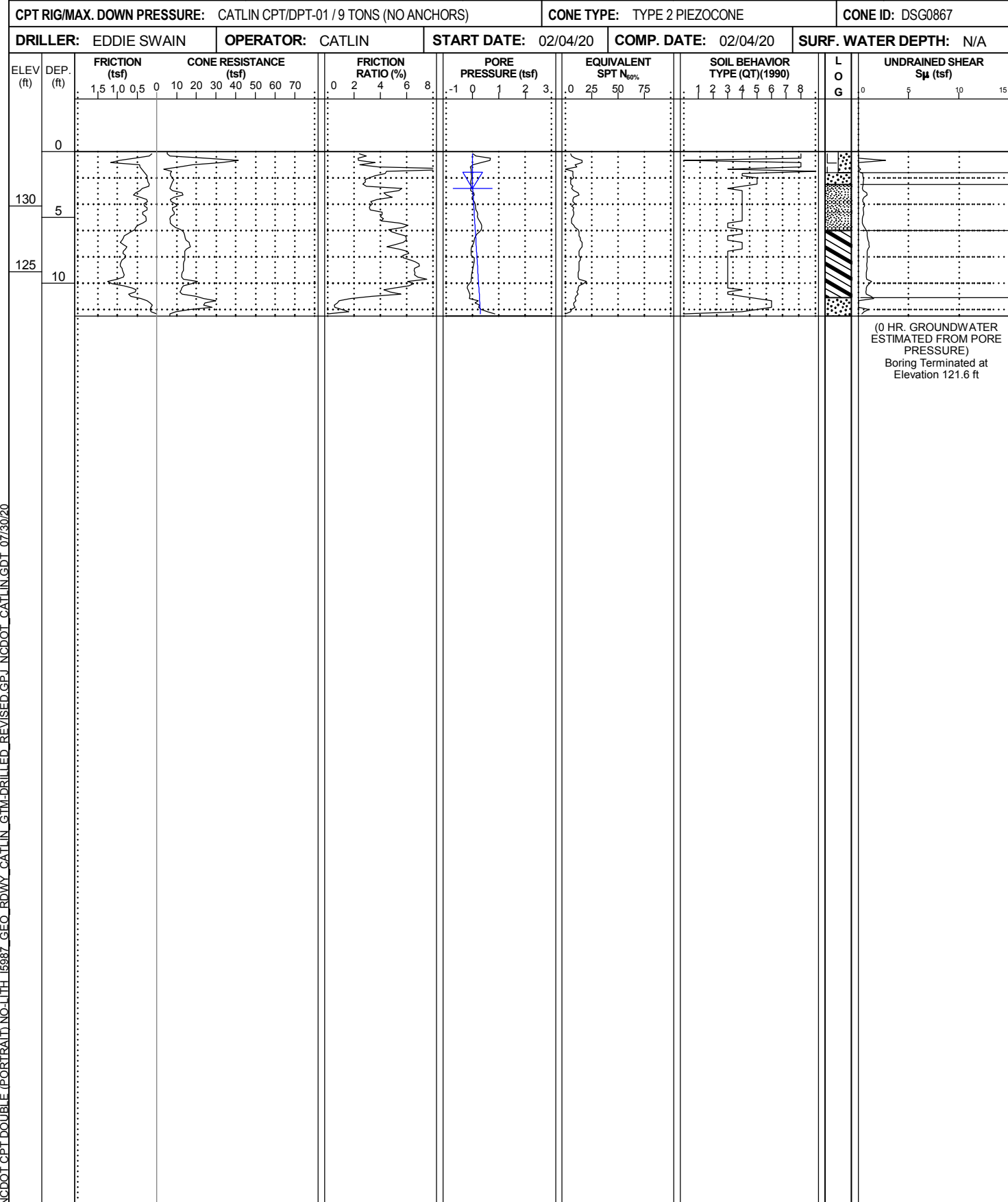

NCDOT CPT DOUBLE (PORTRAIT) NO-LITH 15987\_GEO\_RDWY\_CATLIN\_GTM-DRILLED\_REVISED.GPJ\_NCDOT\_CATLIN.GDT\_07/30/20

# CONE PENETROMETER TEST BORING REPORT



<b>WBS:</b> 47533.1.1	<b>TIP:</b> I-5987A	<b>COUNTY:</b> ROBESON/CUMBERLAND	<b>GEOLOGIST:</b> S. HUDSON
<b>SITE DESCRIPTION:</b> I-95 CUMBERLAND/ROBESON COUNTIES FROM US 301 (EXIT 22) TO I-95 BUSINESS/US 301 (EXIT 40)			<b>GROUND WTR (ft)</b>
<b>BORING NO.:</b> L_18700_RT	<b>STATION:</b> 187+00	<b>OFFSET:</b> 80 ft RT	<b>ALIGNMENT:</b> -L-
<b>COLLAR ELEV.:</b> 141.0 ft	<b>TOTAL DEPTH:</b> 14.5 ft	<b>NORTHING:</b> 343,608	<b>EASTING:</b> 2,000,511
<b>CPT RIG/MAX. DOWN PRESSURE:</b> CATLIN CPT/DPT-01 / 9 TONS (NO ANCHORS)		<b>CONE TYPE:</b> TYPE 2 PIEZOCONE	<b>CONE ID:</b> DSG0867
<b>DRILLER:</b> EDDIE SWAIN	<b>OPERATOR:</b> CATLIN	<b>START DATE:</b> 02/04/20	<b>COMP. DATE:</b> 02/04/20
<b>EST. 0 HR.</b> 1.6		<b>24 HR.</b> N/A	

<b>WBS:</b> 47533.1.1	<b>TIP:</b> I-5987A	<b>COUNTY:</b> ROBESON/CUMBERLAND	<b>GEOLOGIST:</b> S. HUDSON
<b>SITE DESCRIPTION:</b> I-95 CUMBERLAND/ROBESON COUNTIES FROM US 301 (EXIT 22) TO I-95 BUSINESS/US 301 (EXIT 40)			<b>GROUND WTR (ft)</b>
<b>BORING NO.:</b> L_19200_RT	<b>STATION:</b> 192+00	<b>OFFSET:</b> 86 ft RT	<b>ALIGNMENT:</b> -L-
<b>COLLAR ELEV.:</b> 142.1 ft	<b>TOTAL DEPTH:</b> 12.5 ft	<b>NORTHING:</b> 344,110	<b>EASTING:</b> 2,000,542
<b>CPT RIG/MAX. DOWN PRESSURE:</b> CATLIN CPT/DPT-01 / 9 TONS (NO ANCHORS)		<b>CONE TYPE:</b> TYPE 2 PIEZOCONE	<b>CONE ID:</b> DSG0867
<b>DRILLER:</b> EDDIE SWAIN	<b>OPERATOR:</b> CATLIN	<b>START DATE:</b> 02/04/20	<b>COMP. DATE:</b> 02/04/20
<b>EST. 0 HR.</b> 1.6		<b>24 HR.</b> N/A	

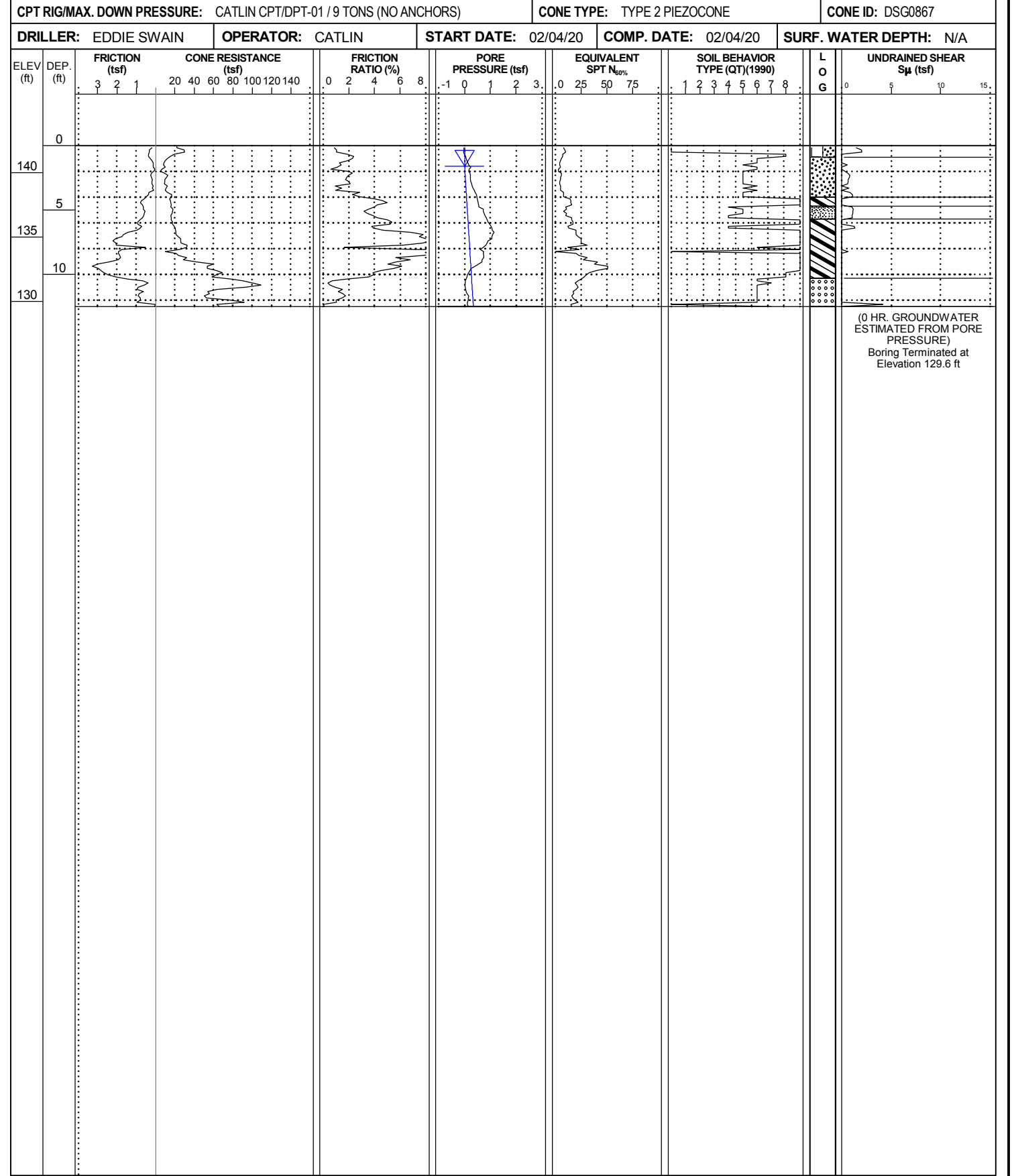
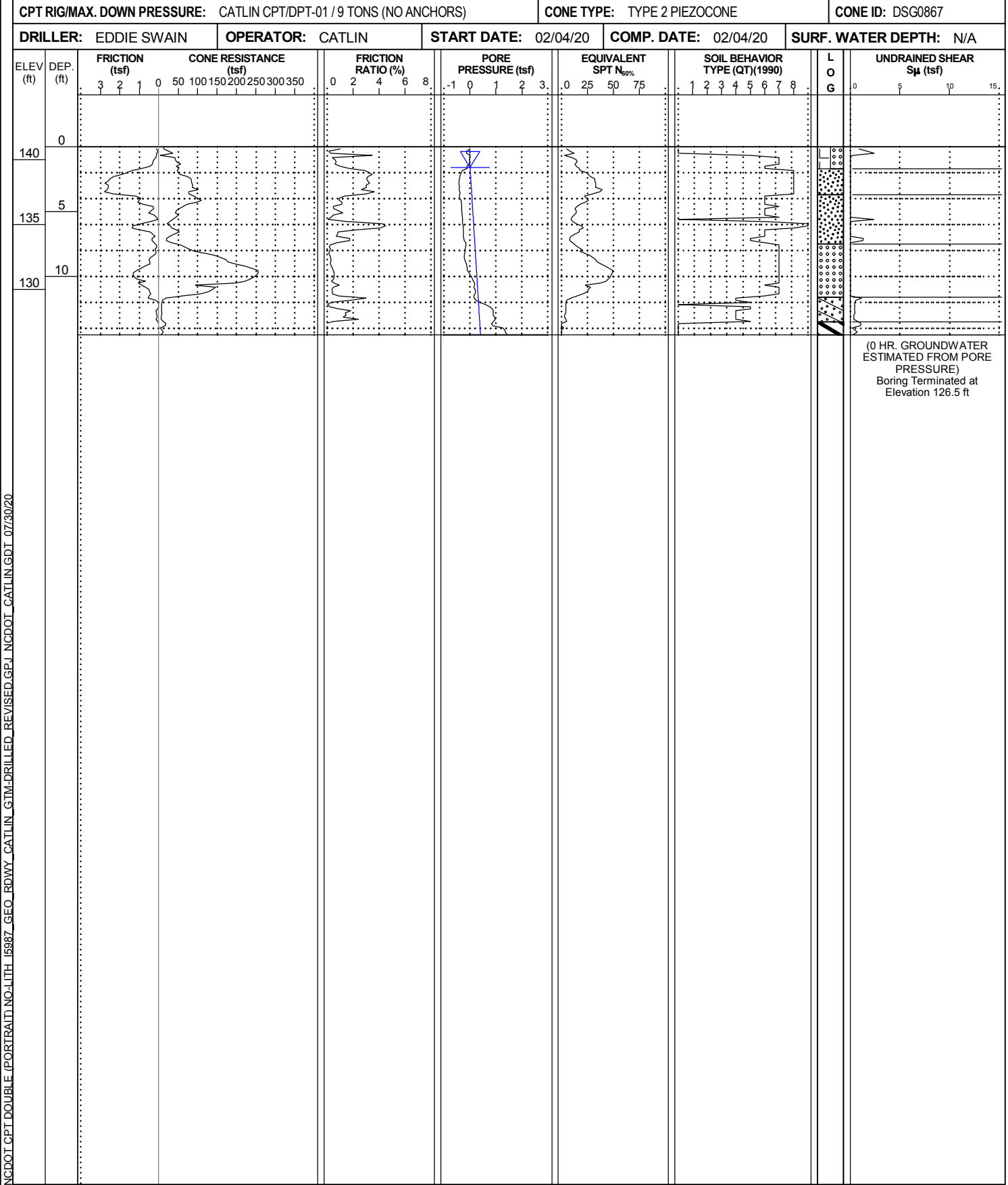

NCDOT CPT DOUBLE (PORTRAIT) NO-LITH 15987\_GEO\_RDWY\_CATLIN\_GTM-DRILLED\_REVISED.GPJ\_NCDOT\_CATLIN.GDT\_07/30/20

# CONE PENETROMETER TEST BORING REPORT



<b>WBS:</b> 47533.1.1	<b>TIP:</b> I-5987A	<b>COUNTY:</b> ROBESON/CUMBERLAND	<b>GEOLOGIST:</b> S. HUDSON
<b>SITE DESCRIPTION:</b> I-95 CUMBERLAND/ROBESON COUNTIES FROM US 301 (EXIT 22) TO I-95 BUSINESS/US 301 (EXIT 40)			<b>GROUND WTR (ft)</b>
<b>BORING NO.:</b> L_20200_LT	<b>STATION:</b> 202+01	<b>OFFSET:</b> 92 ft LT	<b>ALIGNMENT:</b> -L-
<b>COLLAR ELEV.:</b> 143.3 ft	<b>TOTAL DEPTH:</b> 9.1 ft	<b>NORTHING:</b> 345,117	<b>EASTING:</b> 2,000,405
<b>CPT RIG/MAX. DOWN PRESSURE:</b> CATLIN CPT/DPT-01 / 9 TONS (NO ANCHORS)		<b>CONE TYPE:</b> TYPE 2 PIEZOCONE	<b>CONE ID:</b> DSG0867
<b>DRILLER:</b> EDDIE SWAIN	<b>OPERATOR:</b> CATLIN	<b>START DATE:</b> 02/03/20	<b>COMP. DATE:</b> 02/03/20
		<b>SURF. WATER DEPTH:</b> N/A	

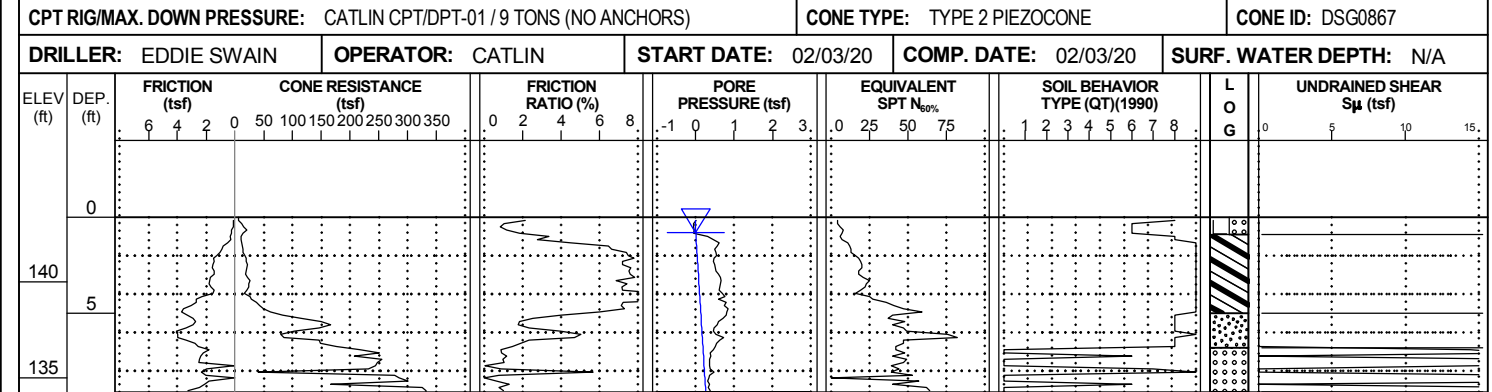

(0 HR. GROUNDWATER ESTIMATED FROM PORE PRESSURE)  
Boring Terminated at Elevation 134.2 ft IN SANDY CLAY

<b>WBS:</b> 47533.1.1	<b>TIP:</b> I-5987A	<b>COUNTY:</b> ROBESON/CUMBERLAND	<b>GEOLOGIST:</b> S. HUDSON
<b>SITE DESCRIPTION:</b> I-95 CUMBERLAND/ROBESON COUNTIES FROM US 301 (EXIT 22) TO I-95 BUSINESS/US 301 (EXIT 40)			<b>GROUND WTR (ft)</b>
<b>BORING NO.:</b> L_20700_LT	<b>STATION:</b> 207+00	<b>OFFSET:</b> 86 ft LT	<b>ALIGNMENT:</b> -L-
<b>COLLAR ELEV.:</b> 144.8 ft	<b>TOTAL DEPTH:</b> 9.4 ft	<b>NORTHING:</b> 345,616	<b>EASTING:</b> 2,000,431
<b>CPT RIG/MAX. DOWN PRESSURE:</b> CATLIN CPT/DPT-01 / 9 TONS (NO ANCHORS)		<b>CONE TYPE:</b> TYPE 2 PIEZOCONE	<b>CONE ID:</b> DSG0867
<b>DRILLER:</b> EDDIE SWAIN	<b>OPERATOR:</b> CATLIN	<b>START DATE:</b> 02/03/20	<b>COMP. DATE:</b> 02/03/20
		<b>SURF. WATER DEPTH:</b> N/A	

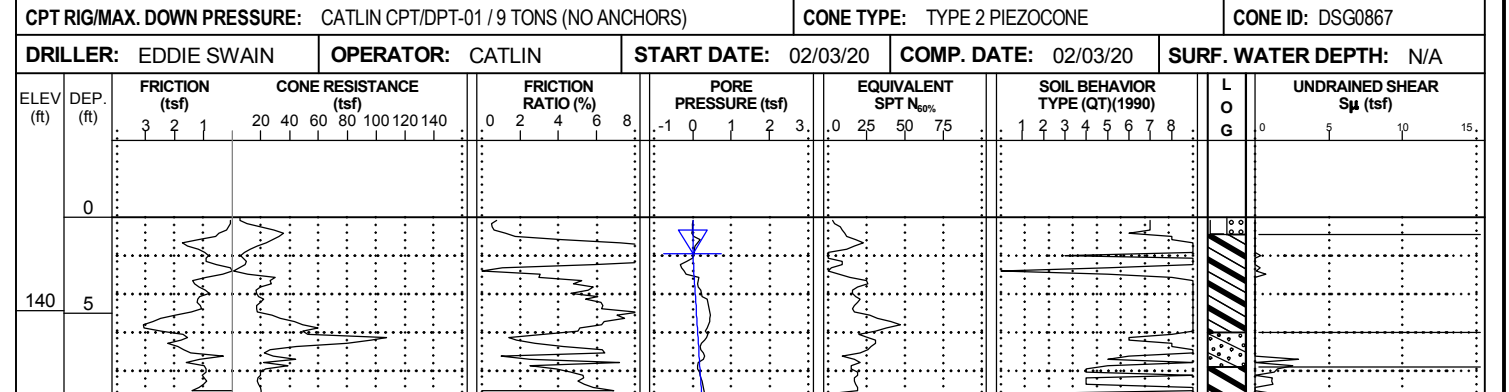

(0 HR. GROUNDWATER ESTIMATED FROM PORE PRESSURE)  
Boring Terminated at Elevation 135.4 ft

NCDOT CPT DOUBLE (PORTRAIT) NO-LITH 15987\_GEO\_ROWY\_CATLIN\_GTM-DRILLED\_REVISED.GPJ\_NCDOT\_CATLIN.GDT\_07/30/20

# CONE PENETROMETER TEST BORING REPORT



<b>WBS:</b> 47533.1.1	<b>TIP:</b> I-5987A	<b>COUNTY:</b> ROBESON/CUMBERLAND	<b>GEOLOGIST:</b> S. HUDSON
<b>SITE DESCRIPTION:</b> I-95 CUMBERLAND/ROBESON COUNTIES FROM US 301 (EXIT 22) TO I-95 BUSINESS/US 301 (EXIT 40)			<b>GROUND WTR (ft)</b>
<b>BORING NO.:</b> L_29200_LT	<b>STATION:</b> 292+00	<b>OFFSET:</b> 74 ft LT	<b>ALIGNMENT:</b> -L-
<b>COLLAR ELEV.:</b> 150.0 ft	<b>TOTAL DEPTH:</b> 9.5 ft	<b>NORTHING:</b> 354,108	<b>EASTING:</b> 2,000,710
<b>CPT RIG/MAX. DOWN PRESSURE:</b> CATLIN CPT/DPT-01 / 9 TONS (NO ANCHORS)		<b>CONE TYPE:</b> TYPE 2 PIEZOcone	<b>CONE ID:</b> DSG0867
<b>DRILLER:</b> EDDIE SWAIN	<b>OPERATOR:</b> CATLIN	<b>START DATE:</b> 02/03/20	<b>COMP. DATE:</b> 02/03/20
		<b>SURF. WATER DEPTH:</b> N/A	

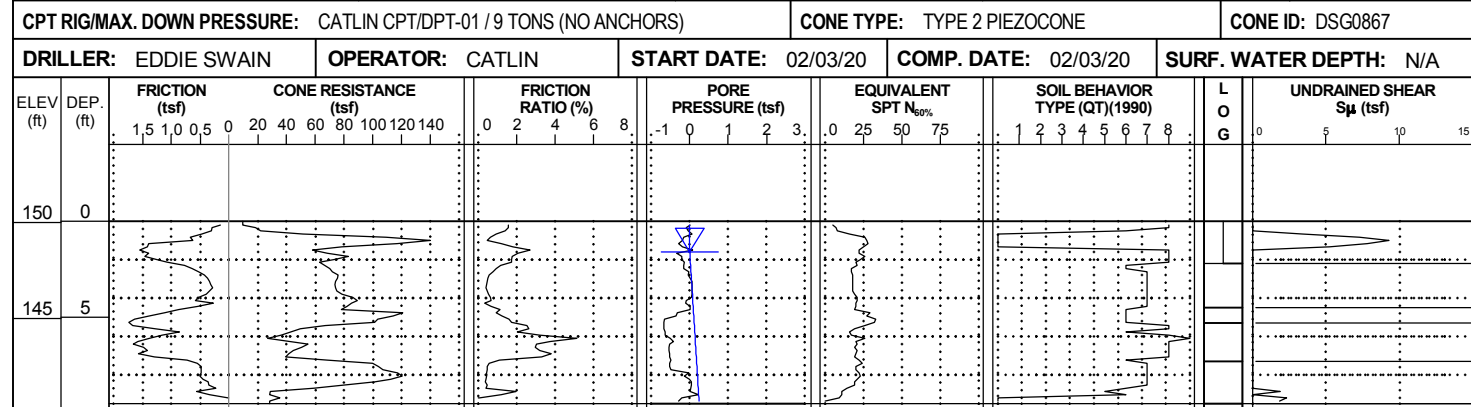

(0 HR. GROUNDWATER ESTIMATED FROM PORE PRESSURE)  
Boring Terminated at Elevation 140.5 ft

<b>WBS:</b> 47533.1.1	<b>TIP:</b> I-5987A	<b>COUNTY:</b> ROBESON/CUMBERLAND	<b>GEOLOGIST:</b> S. HUDSON
<b>SITE DESCRIPTION:</b> I-95 CUMBERLAND/ROBESON COUNTIES FROM US 301 (EXIT 22) TO I-95 BUSINESS/US 301 (EXIT 40)			<b>GROUND WTR (ft)</b>
<b>BORING NO.:</b> L_29700_LT	<b>STATION:</b> 297+00	<b>OFFSET:</b> 77 ft LT	<b>ALIGNMENT:</b> -L-
<b>COLLAR ELEV.:</b> 148.6 ft	<b>TOTAL DEPTH:</b> 12.4 ft	<b>NORTHING:</b> 354,608	<b>EASTING:</b> 2,000,712
<b>CPT RIG/MAX. DOWN PRESSURE:</b> CATLIN CPT/DPT-01 / 9 TONS (NO ANCHORS)		<b>CONE TYPE:</b> TYPE 2 PIEZOcone	<b>CONE ID:</b> DSG0867
<b>DRILLER:</b> EDDIE SWAIN	<b>OPERATOR:</b> CATLIN	<b>START DATE:</b> 01/30/20	<b>COMP. DATE:</b> 01/31/20
		<b>SURF. WATER DEPTH:</b> N/A	

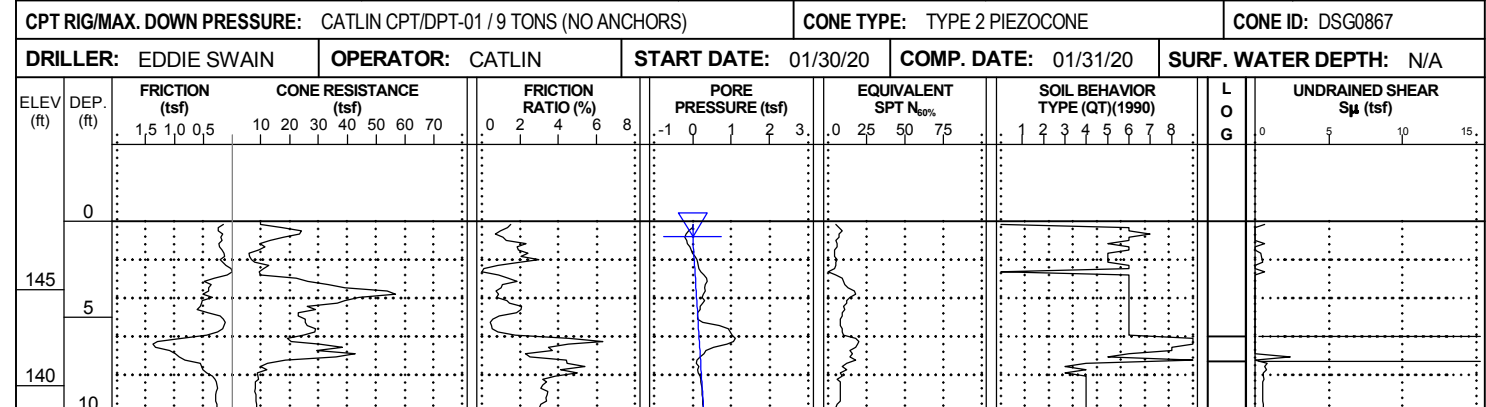

(0 HR. GROUNDWATER ESTIMATED FROM PORE PRESSURE)  
Boring Terminated at Elevation 136.2 ft

NCDOI CPT DOUBLE (PORTRAIT) NO-LITH I5987\_GEO\_ROWY\_CATLIN\_GTM-DRILLED\_REVISED.GPJ\_NCDOT\_CATLIN.GDT\_07/30/20

# CONE PENETROMETER TEST BORING REPORT



<b>WBS:</b> 47533.1.1	<b>TIP:</b> I-5987A	<b>COUNTY:</b> ROBESON/CUMBERLAND	<b>GEOLOGIST:</b> S. HUDSON
<b>SITE DESCRIPTION:</b> I-95 CUMBERLAND/ROBESON COUNTIES FROM US 301 (EXIT 22) TO I-95 BUSINESS/US 301 (EXIT 40)			<b>GROUND WTR (ft)</b>
<b>BORING NO.:</b> L_30200_LT	<b>STATION:</b> 302+00	<b>OFFSET:</b> 82 ft LT	<b>ALIGNMENT:</b> -L-
<b>COLLAR ELEV.:</b> 147.6 ft	<b>TOTAL DEPTH:</b> 14.4 ft	<b>NORTHING:</b> 355,108	<b>EASTING:</b> 2,000,711
<b>CPT RIG/MAX. DOWN PRESSURE:</b> CATLIN CPT/DPT-01 / 9 TONS (NO ANCHORS)		<b>CONE TYPE:</b> TYPE 2 PIEZOCONE	<b>CONE ID:</b> DSG0867
<b>DRILLER:</b> EDDIE SWAIN	<b>OPERATOR:</b> CATLIN	<b>START DATE:</b> 01/30/20	<b>COMP. DATE:</b> 01/31/20
		<b>SURF. WATER DEPTH:</b> N/A	

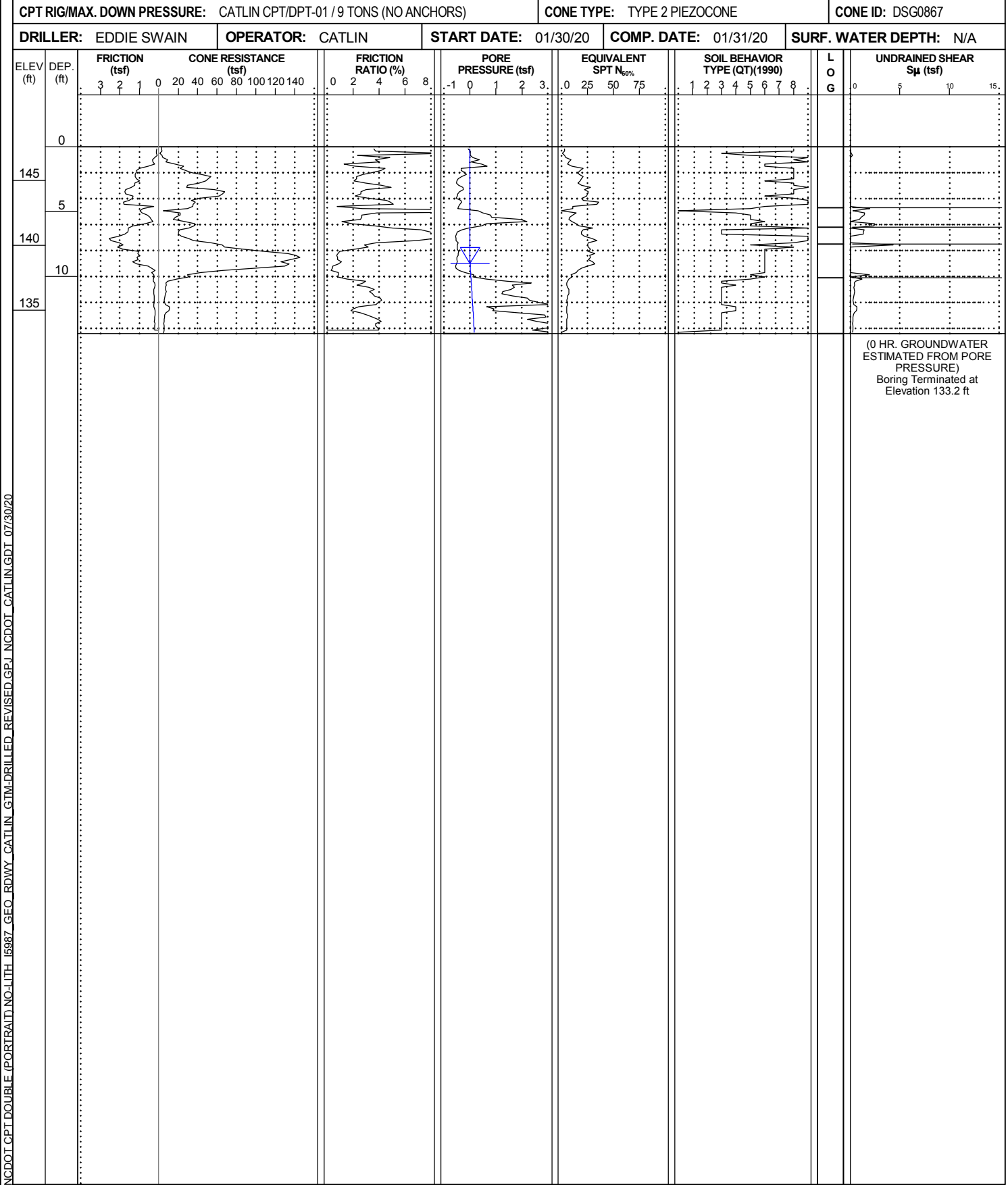

<b>WBS:</b> 47533.1.1	<b>TIP:</b> I-5987A	<b>COUNTY:</b> ROBESON/CUMBERLAND	<b>GEOLOGIST:</b> S. HUDSON
<b>SITE DESCRIPTION:</b> I-95 CUMBERLAND/ROBESON COUNTIES FROM US 301 (EXIT 22) TO I-95 BUSINESS/US 301 (EXIT 40)			<b>GROUND WTR (ft)</b>
<b>BORING NO.:</b> L_30700_LT	<b>STATION:</b> 307+00	<b>OFFSET:</b> 92 ft LT	<b>ALIGNMENT:</b> -L-
<b>COLLAR ELEV.:</b> 147.6 ft	<b>TOTAL DEPTH:</b> 9.6 ft	<b>NORTHING:</b> 355,608	<b>EASTING:</b> 2,000,705
<b>CPT RIG/MAX. DOWN PRESSURE:</b> CATLIN CPT/DPT-01 / 9 TONS (NO ANCHORS)		<b>CONE TYPE:</b> TYPE 2 PIEZOCONE	<b>CONE ID:</b> DSG0867
<b>DRILLER:</b> EDDIE SWAIN	<b>OPERATOR:</b> CATLIN	<b>START DATE:</b> 01/30/20	<b>COMP. DATE:</b> 01/31/20
		<b>SURF. WATER DEPTH:</b> N/A	

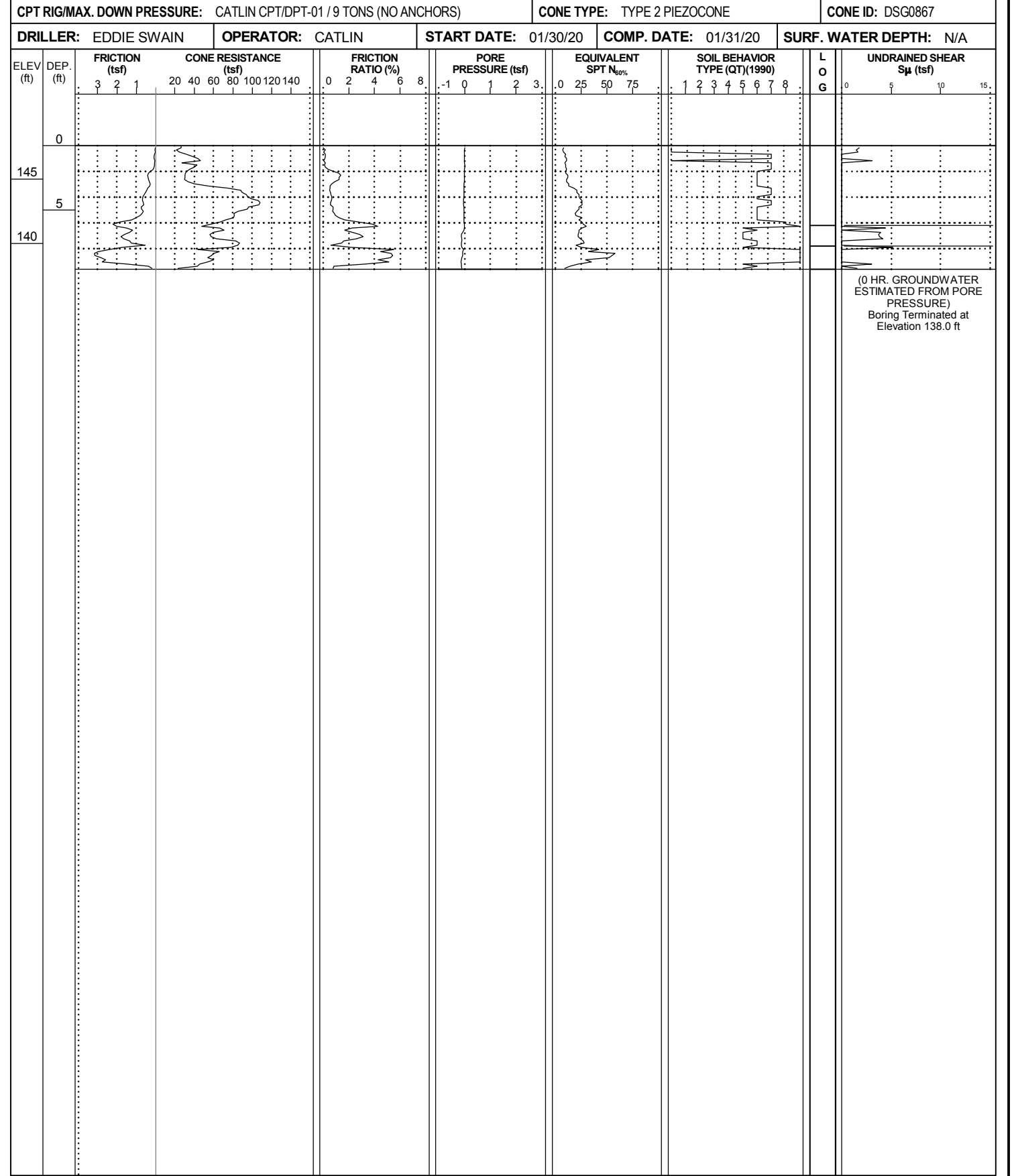

NCDOT CPT DOUBLE (PORTRAIT) NO-LITH 15987\_GEO\_ROWY\_CATLIN\_GTM-DRILLED\_REVISED.GPJ\_NCDOT\_CATLIN.GDT\_07/30/20

# CONE PENETROMETER TEST BORING REPORT



<b>WBS:</b> 47533.1.1	<b>TIP:</b> I-5987A	<b>COUNTY:</b> ROBESON/CUMBERLAND	<b>GEOLOGIST:</b> S. HUDSON
<b>SITE DESCRIPTION:</b> I-95 CUMBERLAND/ROBESON COUNTIES FROM US 301 (EXIT 22) TO I-95 BUSINESS/US 301 (EXIT 40)			<b>GROUND WTR (ft)</b>
<b>BORING NO.:</b> L_31700_RT	<b>STATION:</b> 317+00	<b>OFFSET:</b> 86 ft RT	<b>ALIGNMENT:</b> -L-
<b>COLLAR ELEV.:</b> 140.1 ft	<b>TOTAL DEPTH:</b> 16.1 ft	<b>NORTHING:</b> 356,606	<b>EASTING:</b> 2,000,892
<b>CPT RIG/MAX. DOWN PRESSURE:</b> CATLIN CPT/DPT-01 / 9 TONS (NO ANCHORS)		<b>CONE TYPE:</b> TYPE 2 PIEZOCONE	<b>CONE ID:</b> DSA1123
<b>DRILLER:</b> EDDIE SWAIN	<b>OPERATOR:</b> CATLIN	<b>START DATE:</b> 12/16/19	<b>COMP. DATE:</b> 12/16/19
<b>EST. 0 HR.</b> 2.5		<b>24 HR.</b> N/A	

<b>WBS:</b> 47533.1.1	<b>TIP:</b> I-5987A	<b>COUNTY:</b> ROBESON/CUMBERLAND	<b>GEOLOGIST:</b> S. HUDSON
<b>SITE DESCRIPTION:</b> I-95 CUMBERLAND/ROBESON COUNTIES FROM US 301 (EXIT 22) TO I-95 BUSINESS/US 301 (EXIT 40)			<b>GROUND WTR (ft)</b>
<b>BORING NO.:</b> L_32200_RT	<b>STATION:</b> 322+00	<b>OFFSET:</b> 91 ft RT	<b>ALIGNMENT:</b> -L-
<b>COLLAR ELEV.:</b> 146.3 ft	<b>TOTAL DEPTH:</b> 10.6 ft	<b>NORTHING:</b> 357,106	<b>EASTING:</b> 2,000,901
<b>CPT RIG/MAX. DOWN PRESSURE:</b> CATLIN CPT/DPT-01 / 9 TONS (NO ANCHORS)		<b>CONE TYPE:</b> TYPE 2 PIEZOCONE	<b>CONE ID:</b> DSA1123
<b>DRILLER:</b> EDDIE SWAIN	<b>OPERATOR:</b> CATLIN	<b>START DATE:</b> 12/16/19	<b>COMP. DATE:</b> 12/16/19
<b>EST. 0 HR.</b> 4.8		<b>24 HR.</b> N/A	

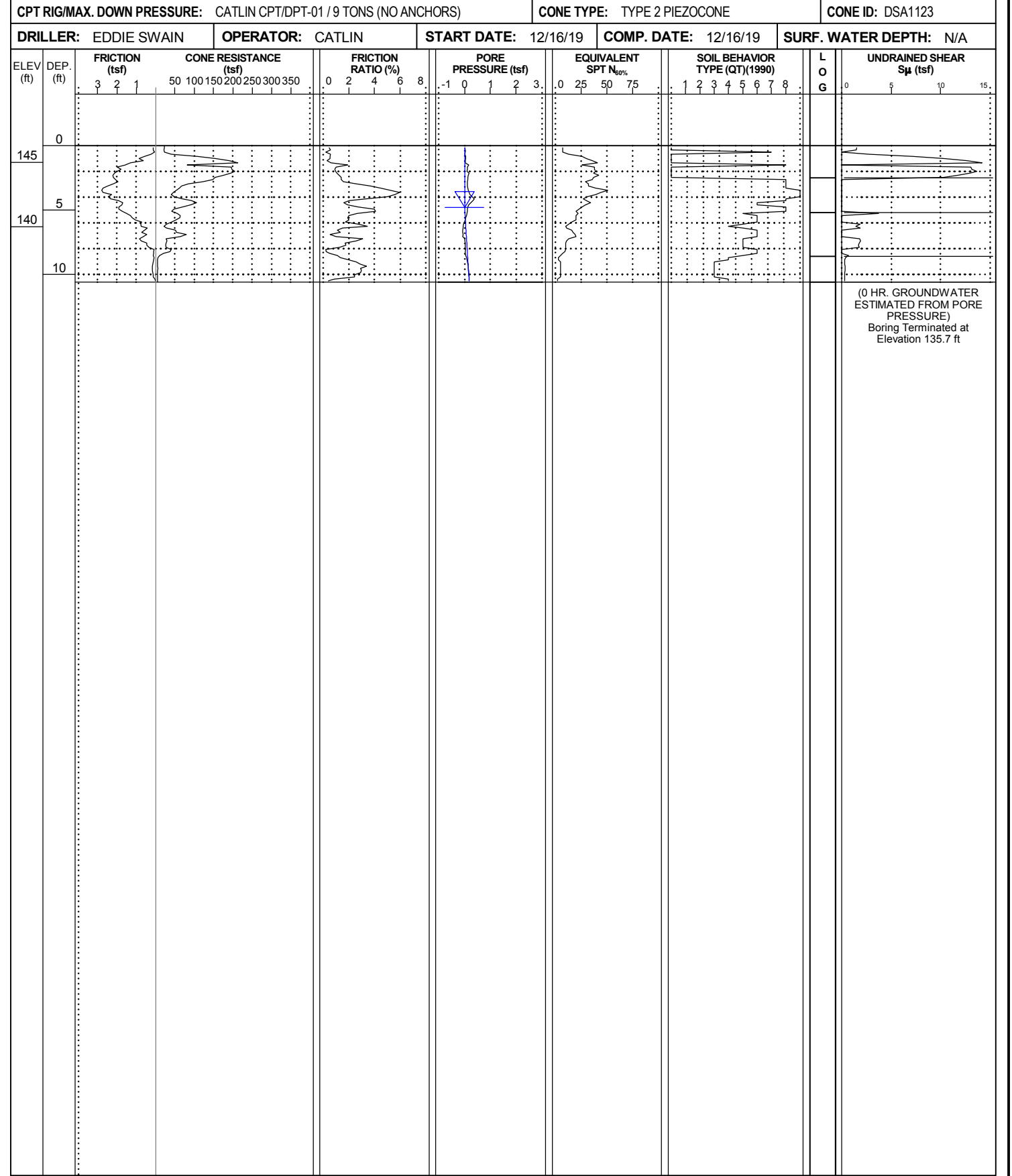
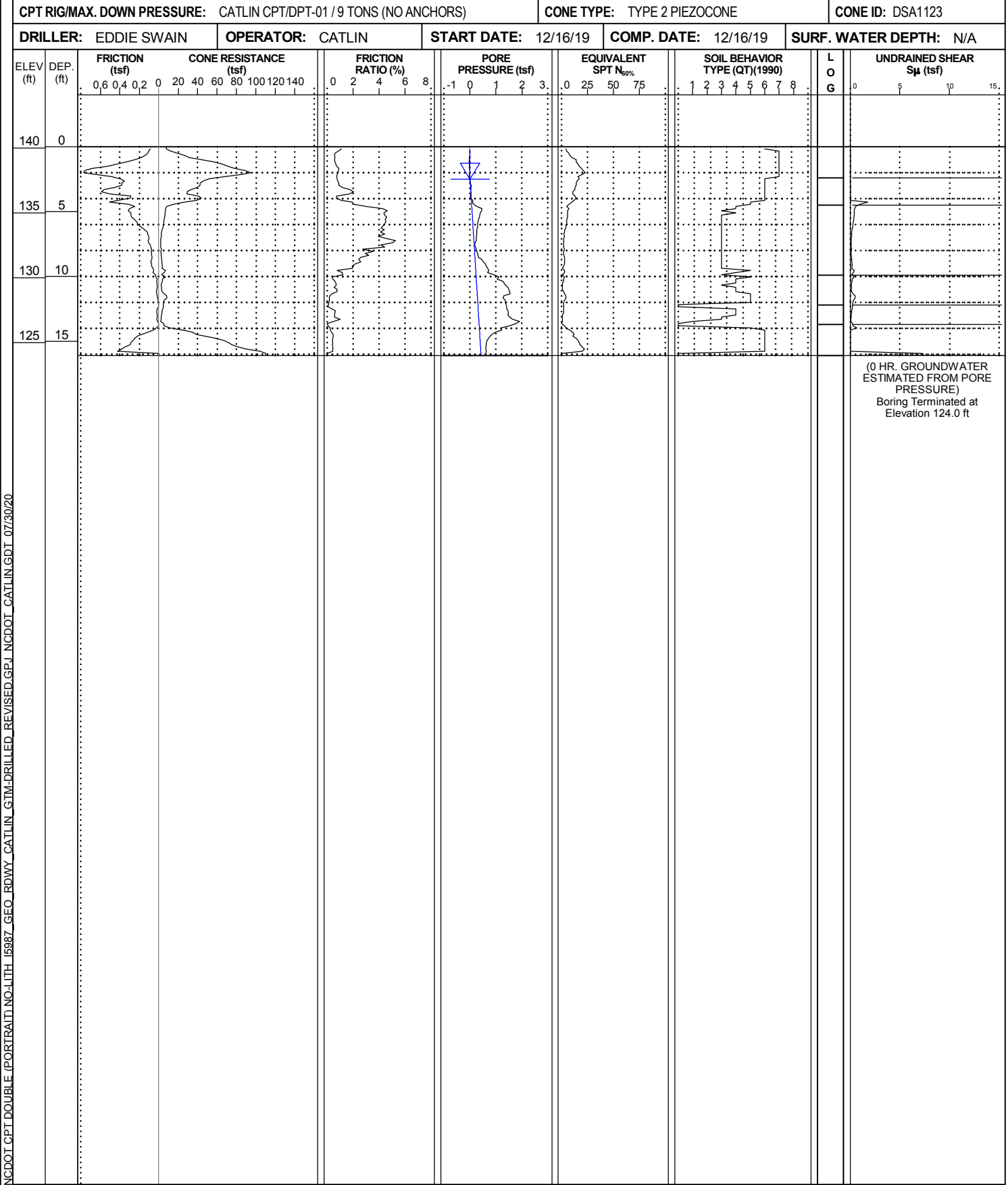

NCDOT CPT DOUBLE (PORTRAIT) NO-LITH 15987\_GEO\_ROWY\_CATLIN\_GTM-DRILLED\_REVISED.GPJ NCDOT\_CATLIN.GDT 07/30/20

# CONE PENETROMETER TEST BORING REPORT



WBS: 47533.1.1	TIP: I-5987A	COUNTY: ROBESON/CUMBERLAND	GEOLOGIST: S. HUDSON
SITE DESCRIPTION: I-95 CUMBERLAND/ROBESON COUNTIES FROM US 301 (EXIT 22) TO I-95 BUSINESS/US 301 (EXIT 40)			GROUND WTR (ft)
BORING NO.: L_32700_RT	STATION: 327+00	OFFSET: 90 ft RT	ALIGNMENT: -L-
COLLAR ELEV.: 149.3 ft	TOTAL DEPTH: 14.0 ft	NORTHING: 357,606	EASTING: 2,000,904
CPT RIG/MAX. DOWN PRESSURE: CATLIN CPT/DPT-01 / 9 TONS (NO ANCHORS)		CONE TYPE: TYPE 2 PIEZOCONE	
DRILLER: EDDIE SWAIN		OPERATOR: CATLIN	
START DATE: 12/16/19		COMP. DATE: 12/16/19	
SURF. WATER DEPTH: N/A		EST. 0 HR. 5.1	
24 HR. N/A			

WBS: 47533.1.1	TIP: I-5987A	COUNTY: ROBESON/CUMBERLAND	GEOLOGIST: S. HUDSON
SITE DESCRIPTION: I-95 CUMBERLAND/ROBESON COUNTIES FROM US 301 (EXIT 22) TO I-95 BUSINESS/US 301 (EXIT 40)			GROUND WTR (ft)
BORING NO.: L_33200_RT	STATION: 332+00	OFFSET: 91 ft RT	ALIGNMENT: -L-
COLLAR ELEV.: 148.4 ft	TOTAL DEPTH: 14.7 ft	NORTHING: 358,106	EASTING: 2,000,910
CPT RIG/MAX. DOWN PRESSURE: CATLIN CPT/DPT-01 / 9 TONS (NO ANCHORS)		CONE TYPE: TYPE 2 PIEZOCONE	
DRILLER: EDDIE SWAIN		OPERATOR: CATLIN	
START DATE: 12/17/19		COMP. DATE: 12/17/19	
SURF. WATER DEPTH: N/A		EST. 0 HR. 0.5	
24 HR. N/A			

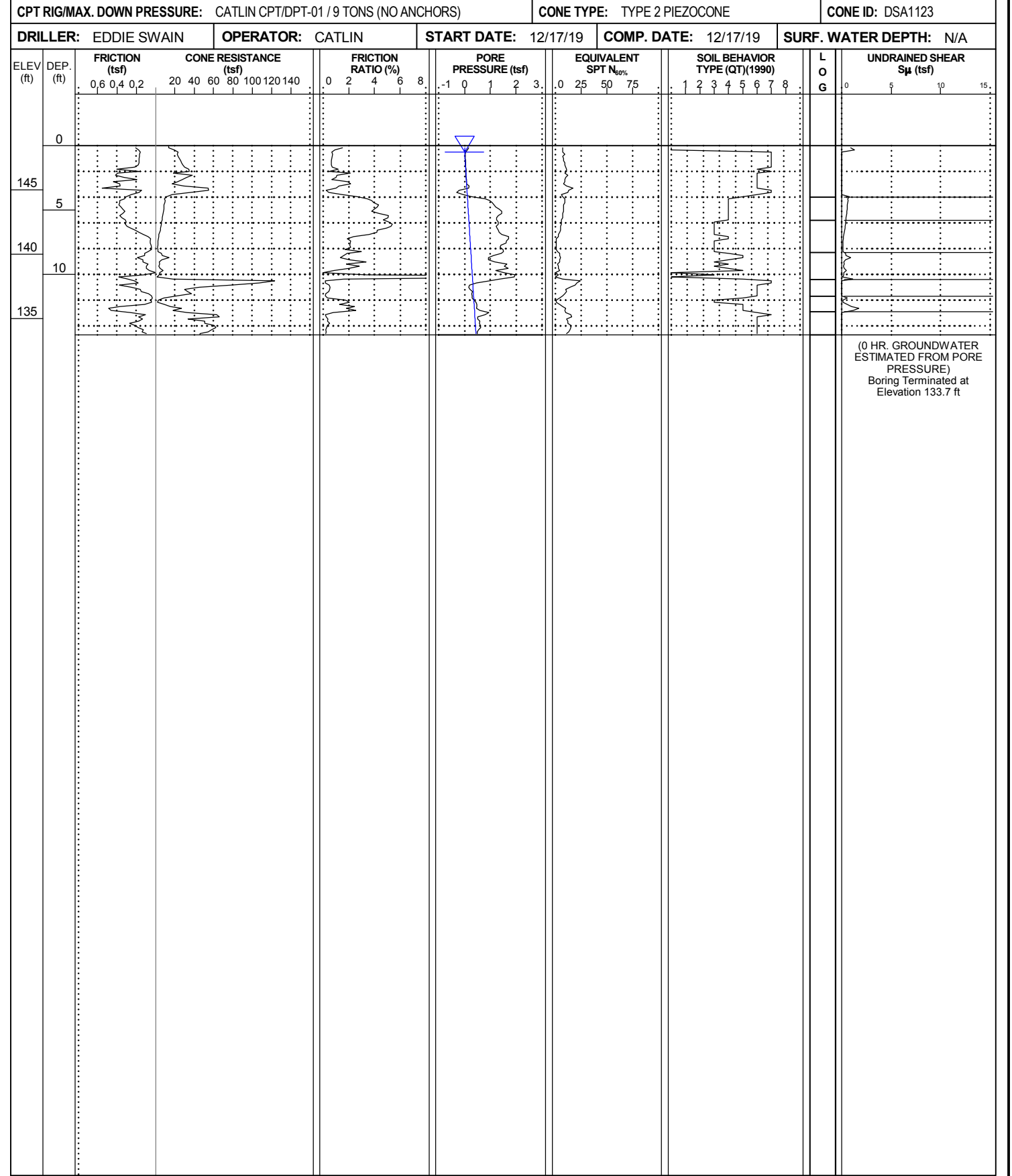
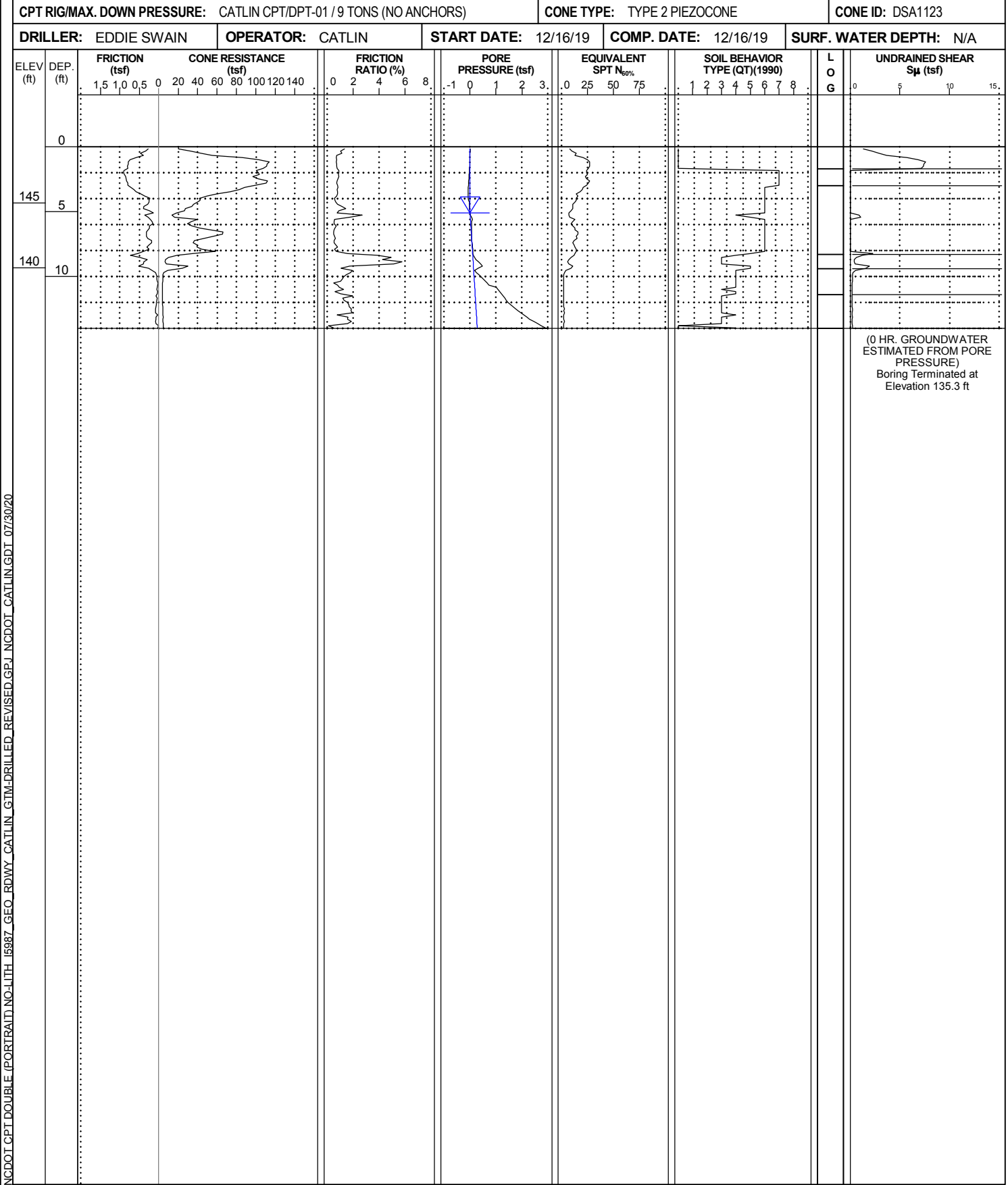

NCDOT CPT DOUBLE (PORTRAIT) NO-LITH 15987\_GEO\_RDWY\_CATLIN\_GTM-DRILLED\_REVISED.GPJ\_NCDOT\_CATLIN.GDT\_07/30/20



# CONE PENETROMETER TEST BORING REPORT



<b>WBS:</b> 47533.1.1	<b>TIP:</b> I-5987A	<b>COUNTY:</b> ROBESON/CUMBERLAND	<b>GEOLOGIST:</b> S. HUDSON
<b>SITE DESCRIPTION:</b> I-95 CUMBERLAND/ROBESON COUNTIES FROM US 301 (EXIT 22) TO I-95 BUSINESS/US 301 (EXIT 40)			<b>GROUND WTR (ft)</b>
<b>BORING NO.:</b> L_33700_RT	<b>STATION:</b> 337+00	<b>OFFSET:</b> 76 ft RT	<b>ALIGNMENT:</b> -L-
<b>COLLAR ELEV.:</b> 146.4 ft	<b>TOTAL DEPTH:</b> 13.8 ft	<b>NORTHING:</b> 358,606	<b>EASTING:</b> 2,000,899
<b>CPT RIG/MAX. DOWN PRESSURE:</b> CATLIN CPT/DPT-01 / 9 TONS (NO ANCHORS)		<b>CONE TYPE:</b> TYPE 2 PIEZOCONE	<b>CONE ID:</b> DSA1123
<b>DRILLER:</b> EDDIE SWAIN	<b>OPERATOR:</b> CATLIN	<b>START DATE:</b> 12/18/19	<b>COMP. DATE:</b> 12/18/19
<b>EST. 0 HR.</b> 2.3		<b>24 HR.</b> N/A	

<b>WBS:</b> 47533.1.1	<b>TIP:</b> I-5987A	<b>COUNTY:</b> ROBESON/CUMBERLAND	<b>GEOLOGIST:</b> S. HUDSON
<b>SITE DESCRIPTION:</b> I-95 CUMBERLAND/ROBESON COUNTIES FROM US 301 (EXIT 22) TO I-95 BUSINESS/US 301 (EXIT 40)			<b>GROUND WTR (ft)</b>
<b>BORING NO.:</b> L_34200_RT	<b>STATION:</b> 342+00	<b>OFFSET:</b> 82 ft RT	<b>ALIGNMENT:</b> -L-
<b>COLLAR ELEV.:</b> 143.4 ft	<b>TOTAL DEPTH:</b> 13.5 ft	<b>NORTHING:</b> 359,106	<b>EASTING:</b> 2,000,909
<b>CPT RIG/MAX. DOWN PRESSURE:</b> CATLIN CPT/DPT-01 / 9 TONS (NO ANCHORS)		<b>CONE TYPE:</b> TYPE 2 PIEZOCONE	<b>CONE ID:</b> DSA1123
<b>DRILLER:</b> EDDIE SWAIN	<b>OPERATOR:</b> CATLIN	<b>START DATE:</b> 12/18/19	<b>COMP. DATE:</b> 12/18/19
<b>EST. 0 HR.</b> 0.8		<b>24 HR.</b> N/A	

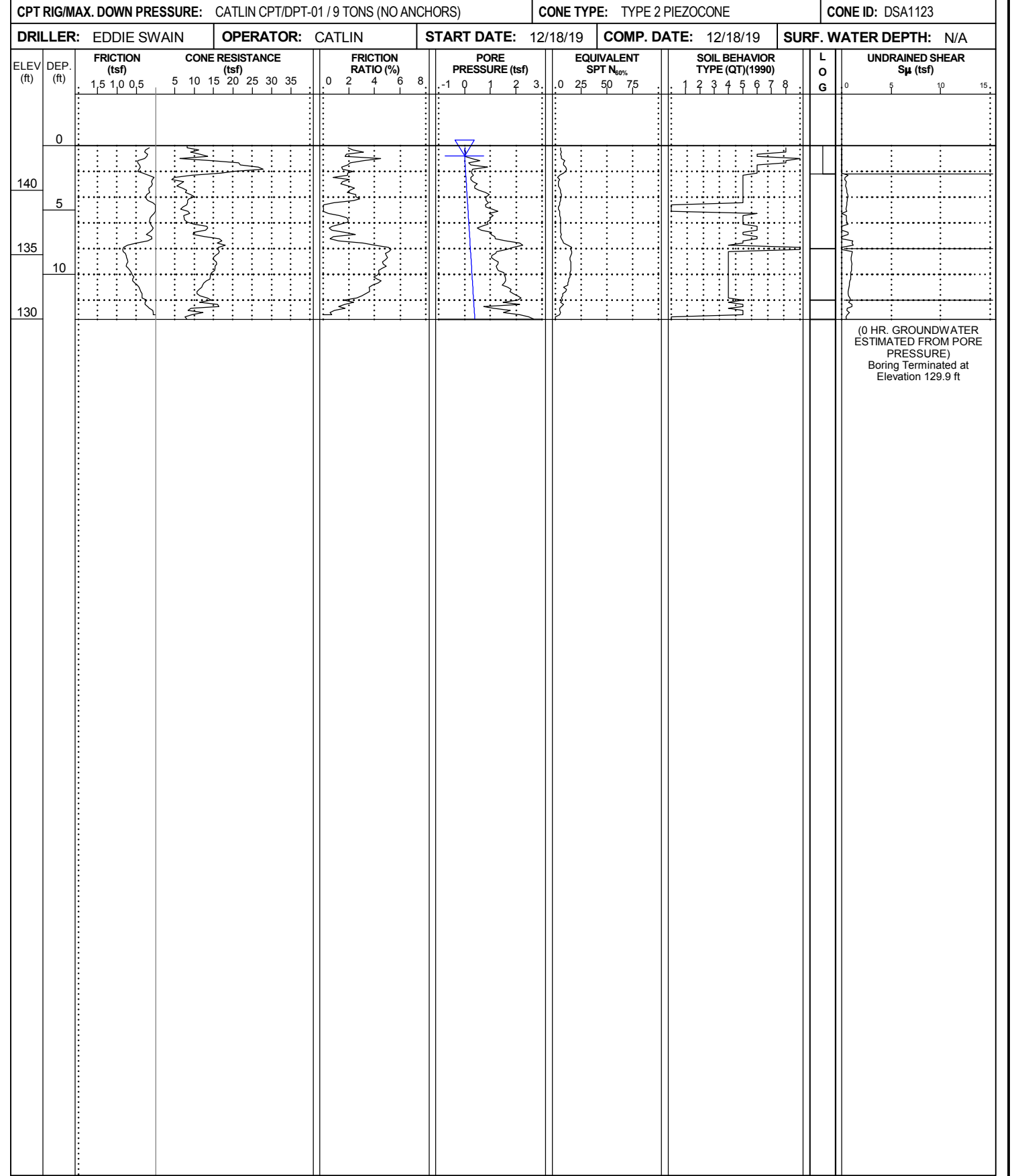
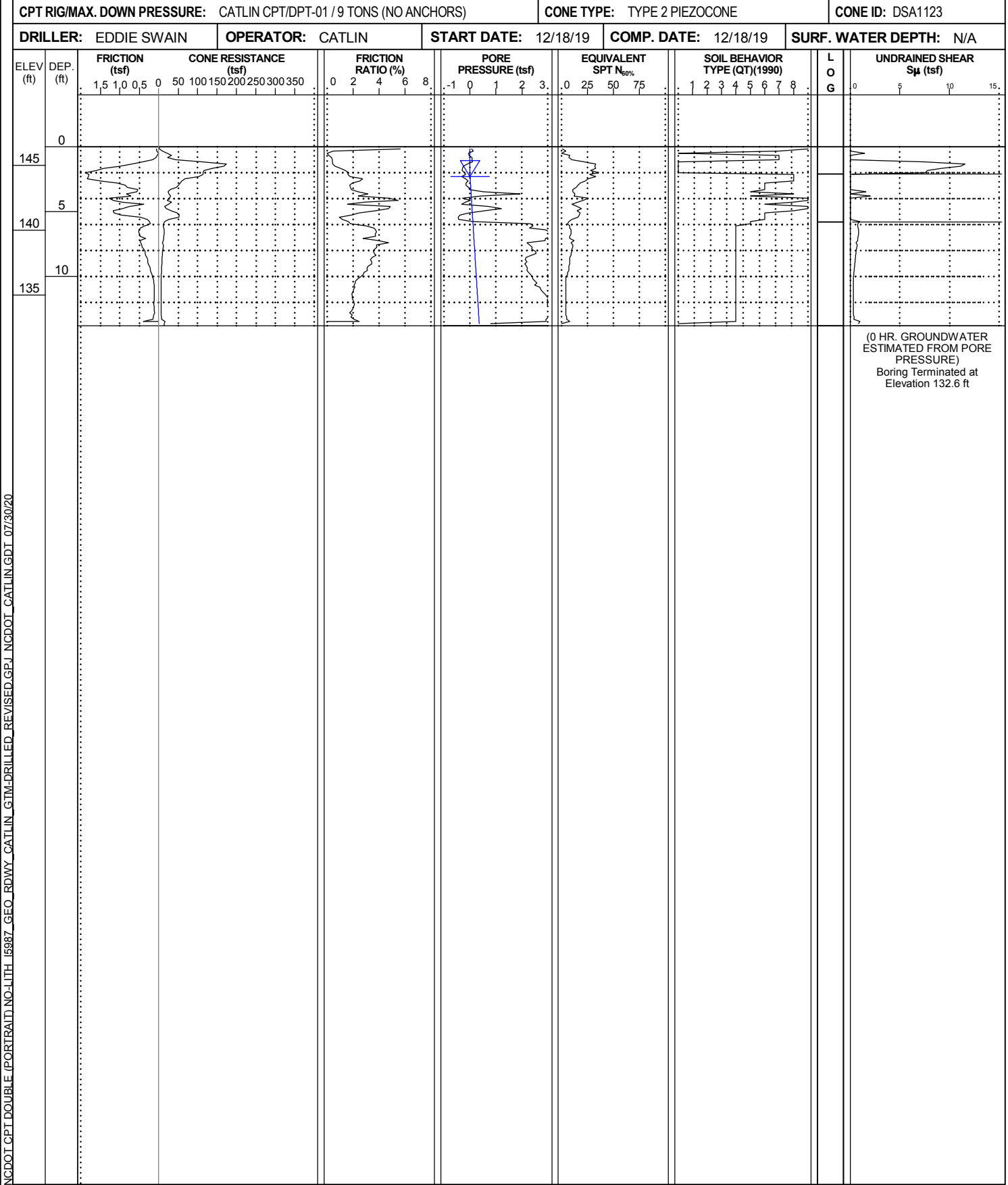

NCDOT CPT DOUBLE (PORTRAIT) NO-LITH 15987\_GEO\_ROWY\_CATLIN\_GTM-DRILLED\_REVISED.GPJ\_NCDOT\_CATLIN.GDT\_07/30/20

# CONE PENETROMETER TEST BORING REPORT



<b>WBS:</b> 47533.1.1	<b>TIP:</b> I-5987A	<b>COUNTY:</b> ROBESON/CUMBERLAND	<b>GEOLOGIST:</b> S. HUDSON
<b>SITE DESCRIPTION:</b> I-95 CUMBERLAND/ROBESON COUNTIES FROM US 301 (EXIT 22) TO I-95 BUSINESS/US 301 (EXIT 40)			<b>GROUND WTR (ft)</b>
<b>BORING NO.:</b> L_34700_RT	<b>STATION:</b> 347+00	<b>OFFSET:</b> 91 ft RT	<b>ALIGNMENT:</b> -L-
<b>COLLAR ELEV.:</b> 144.2 ft	<b>TOTAL DEPTH:</b> 13.6 ft	<b>NORTHING:</b> 359,606	<b>EASTING:</b> 2,000,923
<b>CPT RIG/MAX. DOWN PRESSURE:</b> CATLIN CPT/DPT-01 / 9 TONS (NO ANCHORS)		<b>CONE TYPE:</b> TYPE 2 PIEZOCONE	<b>CONE ID:</b> DSA1123
<b>DRILLER:</b> EDDIE SWAIN	<b>OPERATOR:</b> CATLIN	<b>START DATE:</b> 12/18/19	<b>COMP. DATE:</b> 12/18/19
<b>EST. 0 HR.</b> 1.3		<b>24 HR.</b> N/A	

<b>WBS:</b> 47533.1.1	<b>TIP:</b> I-5987A	<b>COUNTY:</b> ROBESON/CUMBERLAND	<b>GEOLOGIST:</b> S. HUDSON
<b>SITE DESCRIPTION:</b> I-95 CUMBERLAND/ROBESON COUNTIES FROM US 301 (EXIT 22) TO I-95 BUSINESS/US 301 (EXIT 40)			<b>GROUND WTR (ft)</b>
<b>BORING NO.:</b> L_35300_RT	<b>STATION:</b> 353+00	<b>OFFSET:</b> 86 ft RT	<b>ALIGNMENT:</b> -L-
<b>COLLAR ELEV.:</b> 146.2 ft	<b>TOTAL DEPTH:</b> 10.4 ft	<b>NORTHING:</b> 360,206	<b>EASTING:</b> 2,000,923
<b>CPT RIG/MAX. DOWN PRESSURE:</b> CATLIN CPT/DPT-01 / 9 TONS (NO ANCHORS)		<b>CONE TYPE:</b> TYPE 2 PIEZOCONE	<b>CONE ID:</b> DSA1123
<b>DRILLER:</b> EDDIE SWAIN	<b>OPERATOR:</b> CATLIN	<b>START DATE:</b> 12/18/19	<b>COMP. DATE:</b> 12/18/19
<b>EST. 0 HR.</b> 0.8		<b>24 HR.</b> N/A	

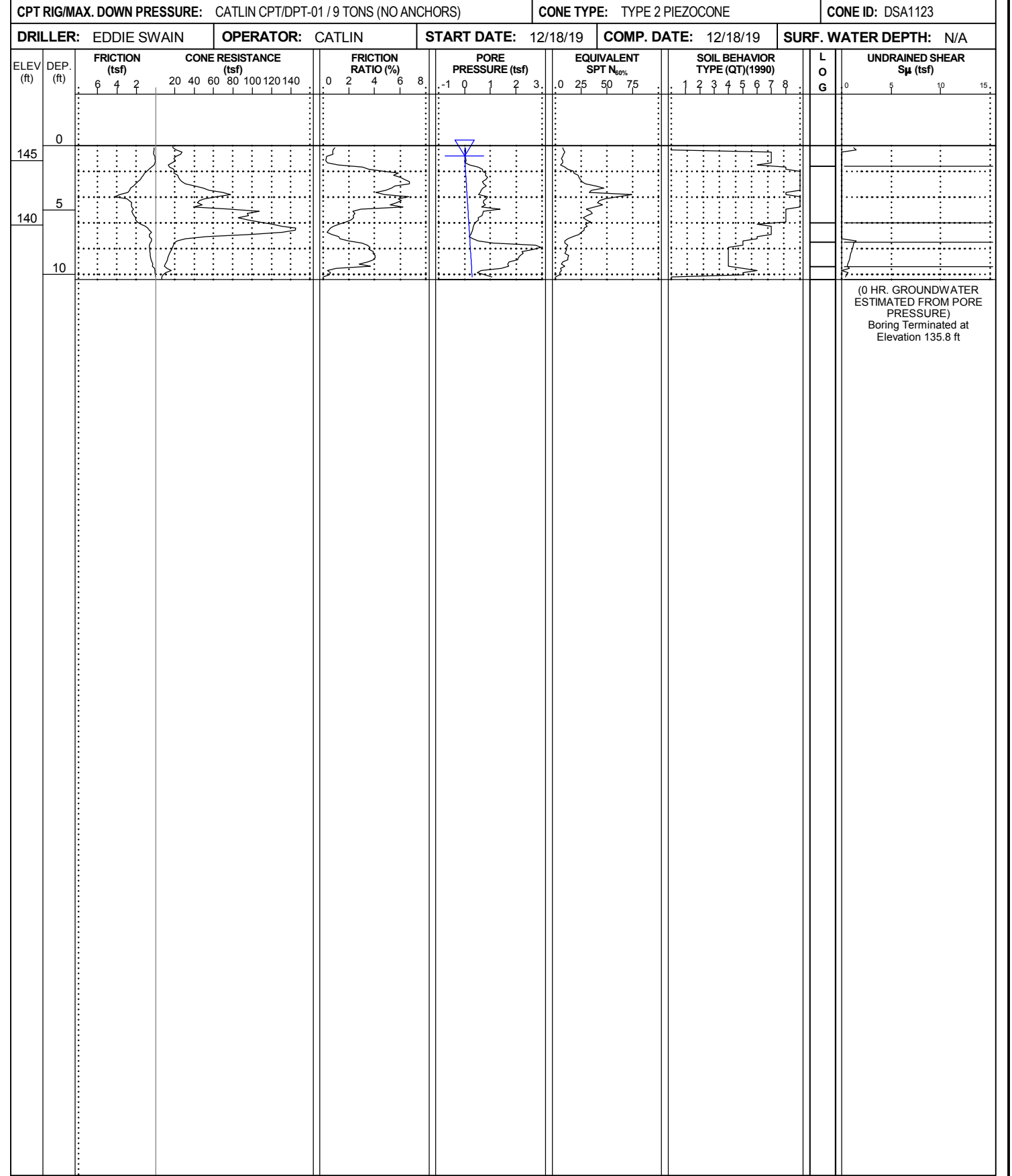
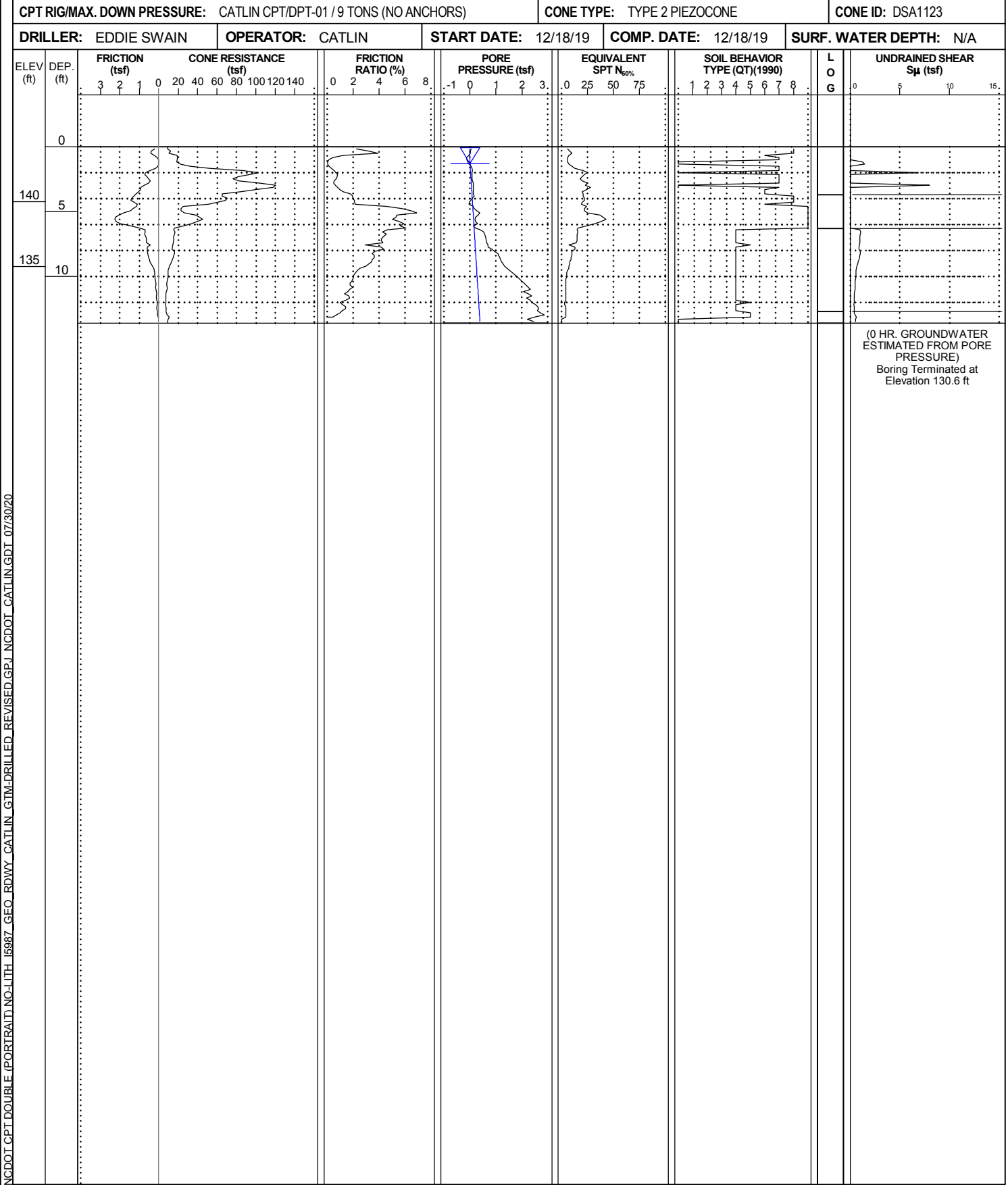

NCDOT CPT DOUBLE (PORTRAIT) NO-LITH 15987\_GEO\_ROWY\_CATLIN\_GTM-DRILLED\_REVISED.GPJ\_NCDOT\_CATLIN.GDT\_07/30/20

# CONE PENETROMETER TEST BORING REPORT



<b>WBS:</b> 47533.1.1	<b>TIP:</b> I-5987A	<b>COUNTY:</b> ROBESON/CUMBERLAND	<b>GEOLOGIST:</b> S. HUDSON
<b>SITE DESCRIPTION:</b> I-95 CUMBERLAND/ROBESON COUNTIES FROM US 301 (EXIT 22) TO I-95 BUSINESS/US 301 (EXIT 40)			<b>GROUND WTR (ft)</b>
<b>BORING NO.:</b> L_35800_LT	<b>STATION:</b> 358+00	<b>OFFSET:</b> 77 ft LT	<b>ALIGNMENT:</b> -L-
<b>COLLAR ELEV.:</b> 147.2 ft	<b>TOTAL DEPTH:</b> 12.6 ft	<b>NORTHING:</b> 360,708	<b>EASTING:</b> 2,000,764
<b>CPT RIG/MAX. DOWN PRESSURE:</b> CATLIN CPT/DPT-01 / 9 TONS (NO ANCHORS)		<b>CONE TYPE:</b> TYPE 2 PIEZOCONE	<b>CONE ID:</b> DSG0867
<b>DRILLER:</b> EDDIE SWAIN	<b>OPERATOR:</b> CATLIN	<b>START DATE:</b> 01/30/20	<b>COMP. DATE:</b> 01/31/20
<b>EST. 0 HR.</b> 5.7		<b>24 HR.</b> N/A	

<b>WBS:</b> 47533.1.1	<b>TIP:</b> I-5987A	<b>COUNTY:</b> ROBESON/CUMBERLAND	<b>GEOLOGIST:</b> S. HUDSON
<b>SITE DESCRIPTION:</b> I-95 CUMBERLAND/ROBESON COUNTIES FROM US 301 (EXIT 22) TO I-95 BUSINESS/US 301 (EXIT 40)			<b>GROUND WTR (ft)</b>
<b>BORING NO.:</b> L_36300_LT	<b>STATION:</b> 363+00	<b>OFFSET:</b> 78 ft LT	<b>ALIGNMENT:</b> -L-
<b>COLLAR ELEV.:</b> 146.7 ft	<b>TOTAL DEPTH:</b> 12.4 ft	<b>NORTHING:</b> 361,208	<b>EASTING:</b> 2,000,767
<b>CPT RIG/MAX. DOWN PRESSURE:</b> CATLIN CPT/DPT-01 / 9 TONS (NO ANCHORS)		<b>CONE TYPE:</b> TYPE 2 PIEZOCONE	<b>CONE ID:</b> DSG0867
<b>DRILLER:</b> EDDIE SWAIN	<b>OPERATOR:</b> CATLIN	<b>START DATE:</b> 01/30/20	<b>COMP. DATE:</b> 01/31/20
<b>EST. 0 HR.</b> 1.4		<b>24 HR.</b> N/A	

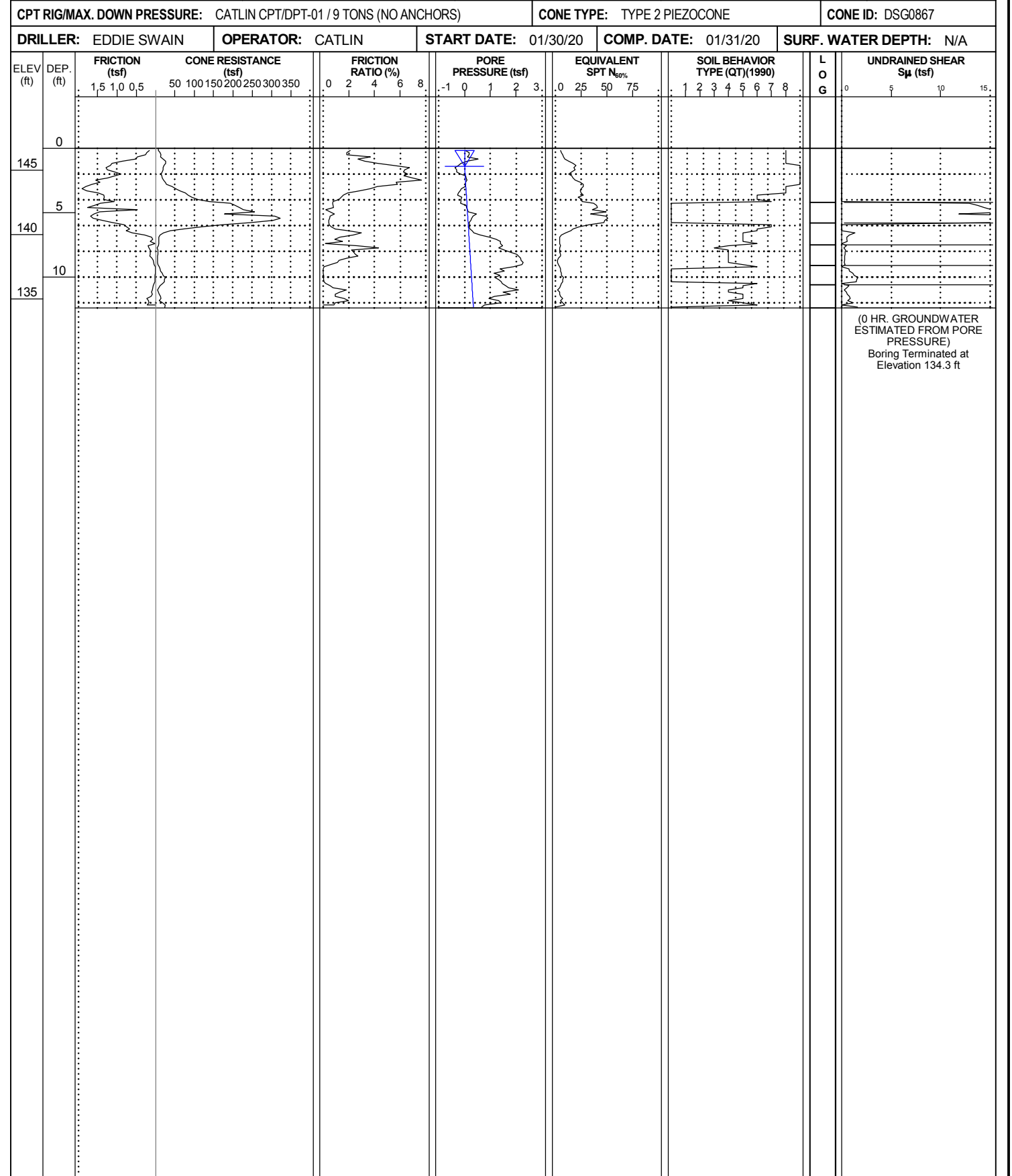
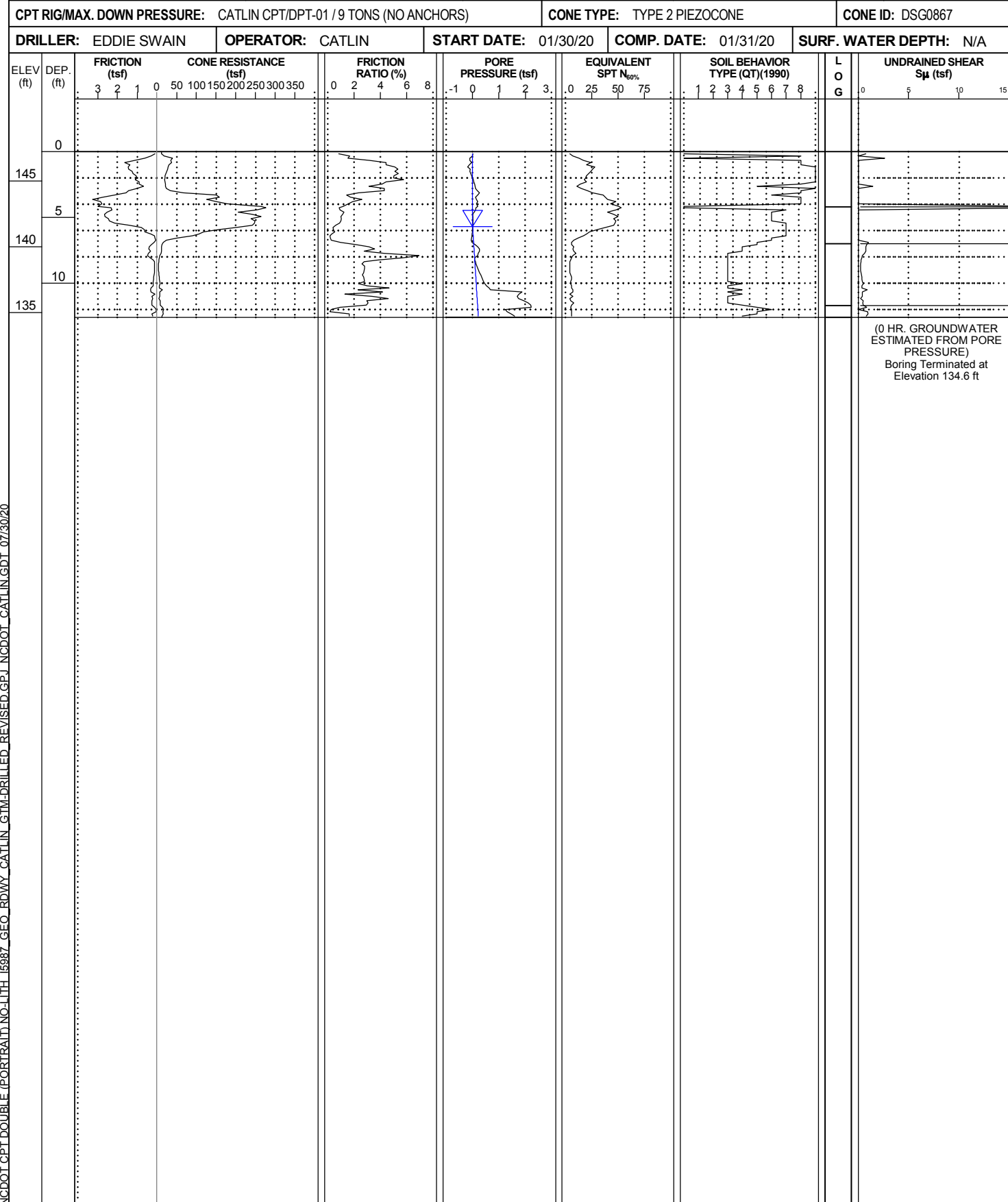

NCDOT CPT DOUBLE (PORTRAIT) NO-LITH 15987\_GEO\_RDWY\_CATLIN\_GTM-DRILLED\_REVISED.GPJ\_NCDOT\_CATLIN.GDT\_07/30/20

# CONE PENETROMETER TEST BORING REPORT



WBS: 47533.1.1	TIP: I-5987A	COUNTY: ROBESON/CUMBERLAND	GEOLOGIST: S. HUDSON
SITE DESCRIPTION: I-95 CUMBERLAND/ROBESON COUNTIES FROM US 301 (EXIT 22) TO I-95 BUSINESS/US 301 (EXIT 40)			GROUND WTR (ft)
BORING NO.: L_37300_RT	STATION: 373+00	OFFSET: 81 ft RT	ALIGNMENT: -L-
COLLAR ELEV.: 146.3 ft	TOTAL DEPTH: 13.5 ft	NORTHING: 362,206	EASTING: 2,000,935
CPT RIG/MAX. DOWN PRESSURE: CATLIN CPT/DPT-01 / 9 TONS (NO ANCHORS)		CONE TYPE: TYPE 2 PIEZOCONE	
DRILLER: EDDIE SWAIN		OPERATOR: CATLIN	
START DATE: 12/18/19		COMP. DATE: 12/18/19	
SURF. WATER DEPTH: N/A			

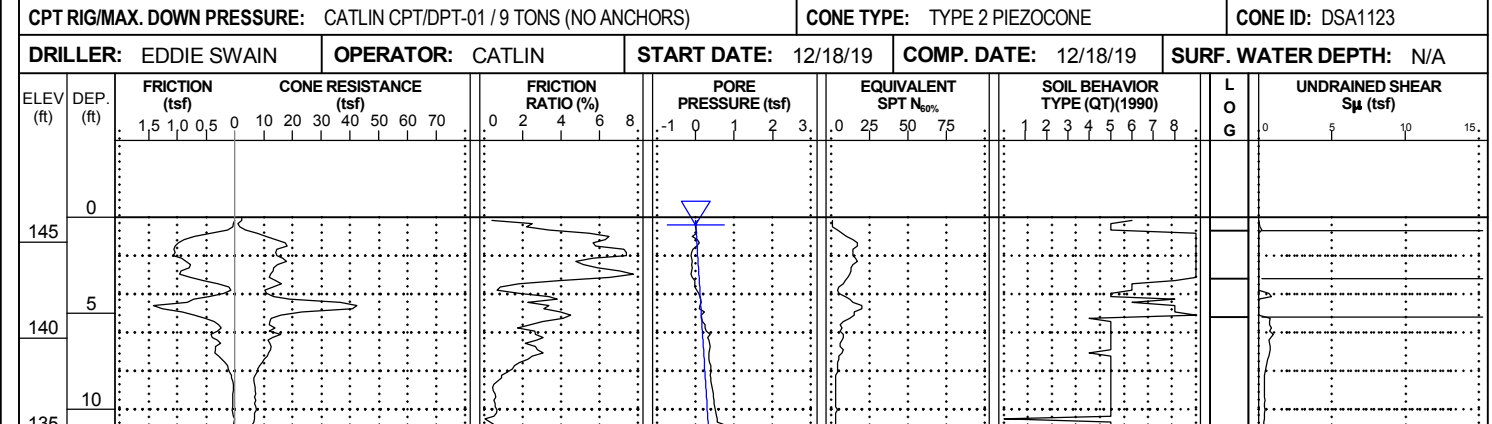

(0 HR. GROUNDWATER ESTIMATED FROM PORE PRESSURE)  
Boring Terminated at Elevation 132.8 ft

WBS: 47533.1.1	TIP: I-5987A	COUNTY: ROBESON/CUMBERLAND	GEOLOGIST: S. HUDSON
SITE DESCRIPTION: I-95 CUMBERLAND/ROBESON COUNTIES FROM US 301 (EXIT 22) TO I-95 BUSINESS/US 301 (EXIT 40)			GROUND WTR (ft)
BORING NO.: L_37800_RT	STATION: 378+00	OFFSET: 87 ft RT	ALIGNMENT: -L-
COLLAR ELEV.: 148.1 ft	TOTAL DEPTH: 10.2 ft	NORTHING: 362,706	EASTING: 2,000,945
CPT RIG/MAX. DOWN PRESSURE: CATLIN CPT/DPT-01 / 9 TONS (NO ANCHORS)		CONE TYPE: TYPE 2 PIEZOCONE	
DRILLER: EDDIE SWAIN		OPERATOR: CATLIN	
START DATE: 12/18/19		COMP. DATE: 12/18/19	
SURF. WATER DEPTH: N/A			

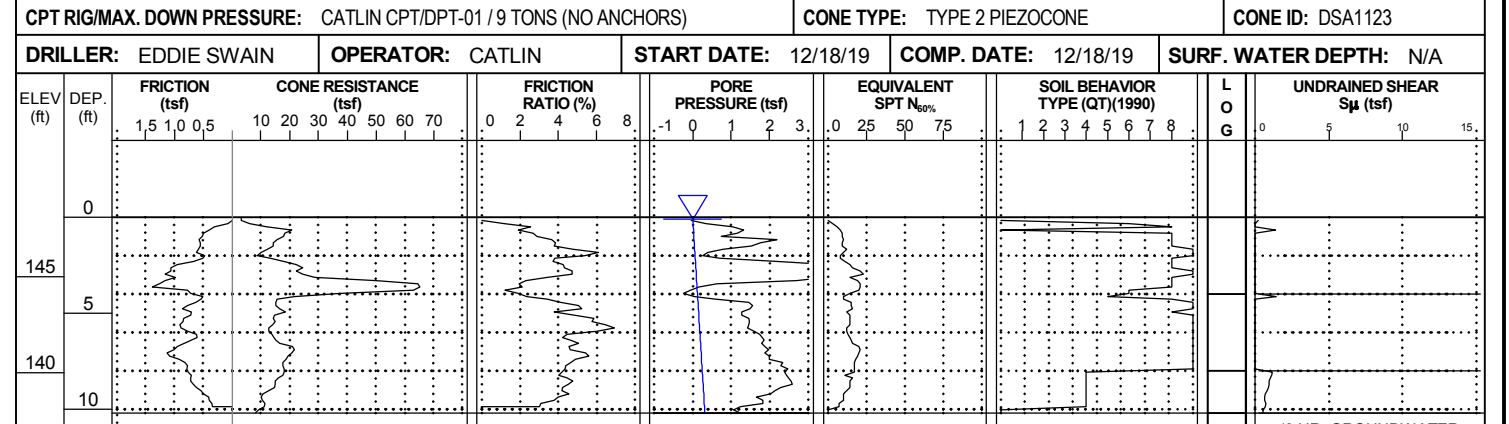

(0 HR. GROUNDWATER ESTIMATED FROM PORE PRESSURE)  
Boring Terminated at Elevation 137.9 ft

NCDOT CPT DOUBLE (PORTRAIT) NO-LITH 15987\_GEO\_RDWY\_CATLIN\_GTM-DRILLED\_REVISED.GPJ NCDOT\_CATLIN.GDT 07/30/20

# CONE PENETROMETER TEST BORING REPORT



<b>WBS:</b> 47533.1.1	<b>TIP:</b> I-5987A	<b>COUNTY:</b> ROBESON/CUMBERLAND	<b>GEOLOGIST:</b> S. HUDSON
<b>SITE DESCRIPTION:</b> I-95 CUMBERLAND/ROBESON COUNTIES FROM US 301 (EXIT 22) TO I-95 BUSINESS/US 301 (EXIT 40)			<b>GROUND WTR (ft)</b>
<b>BORING NO.:</b> L_38300_RT	<b>STATION:</b> 383+00	<b>OFFSET:</b> 81 ft RT	<b>ALIGNMENT:</b> -L-
<b>COLLAR ELEV.:</b> 151.5 ft	<b>TOTAL DEPTH:</b> 9.4 ft	<b>NORTHING:</b> 363,206	<b>EASTING:</b> 2,000,944
<b>CPT RIG/MAX. DOWN PRESSURE:</b> CATLIN CPT/DPT-01 / 9 TONS (NO ANCHORS)		<b>CONE TYPE:</b> TYPE 2 PIEZOCONE	<b>CONE ID:</b> DSA1123
<b>DRILLER:</b> EDDIE SWAIN	<b>OPERATOR:</b> CATLIN	<b>START DATE:</b> 12/18/19	<b>COMP. DATE:</b> 12/18/19
		<b>SURF. WATER DEPTH:</b> N/A	

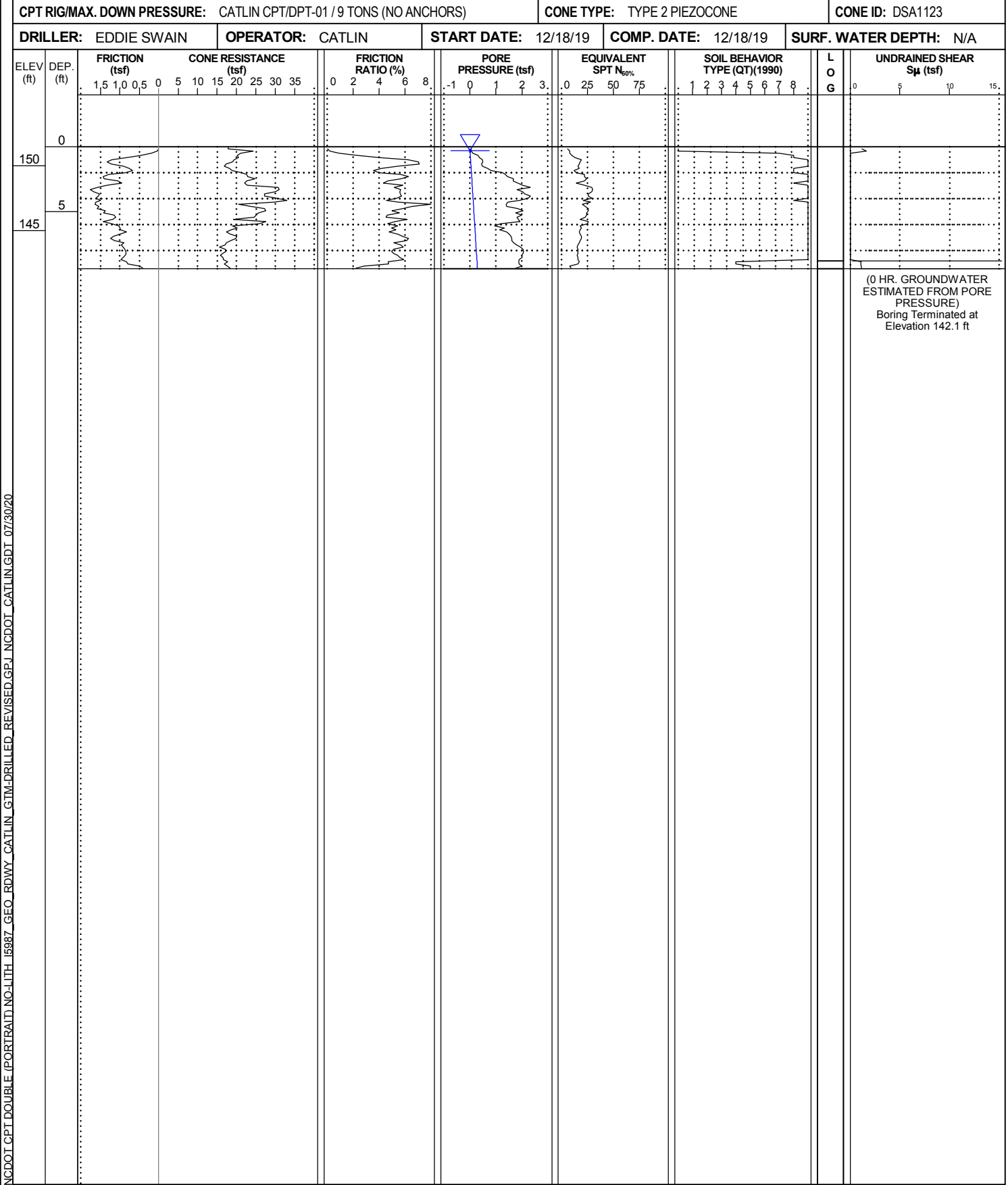

<b>WBS:</b> 47533.1.1	<b>TIP:</b> I-5987A	<b>COUNTY:</b> ROBESON/CUMBERLAND	<b>GEOLOGIST:</b> S. HUDSON
<b>SITE DESCRIPTION:</b> I-95 CUMBERLAND/ROBESON COUNTIES FROM US 301 (EXIT 22) TO I-95 BUSINESS/US 301 (EXIT 40)			<b>GROUND WTR (ft)</b>
<b>BORING NO.:</b> L_38800_RT	<b>STATION:</b> 388+00	<b>OFFSET:</b> 86 ft RT	<b>ALIGNMENT:</b> -L-
<b>COLLAR ELEV.:</b> 152.2 ft	<b>TOTAL DEPTH:</b> 12.5 ft	<b>NORTHING:</b> 363,706	<b>EASTING:</b> 2,000,953
<b>CPT RIG/MAX. DOWN PRESSURE:</b> CATLIN CPT/DPT-01 / 9 TONS (NO ANCHORS)		<b>CONE TYPE:</b> TYPE 2 PIEZOCONE	<b>CONE ID:</b> DSA1123
<b>DRILLER:</b> EDDIE SWAIN	<b>OPERATOR:</b> CATLIN	<b>START DATE:</b> 12/18/19	<b>COMP. DATE:</b> 12/18/19
		<b>SURF. WATER DEPTH:</b> N/A	

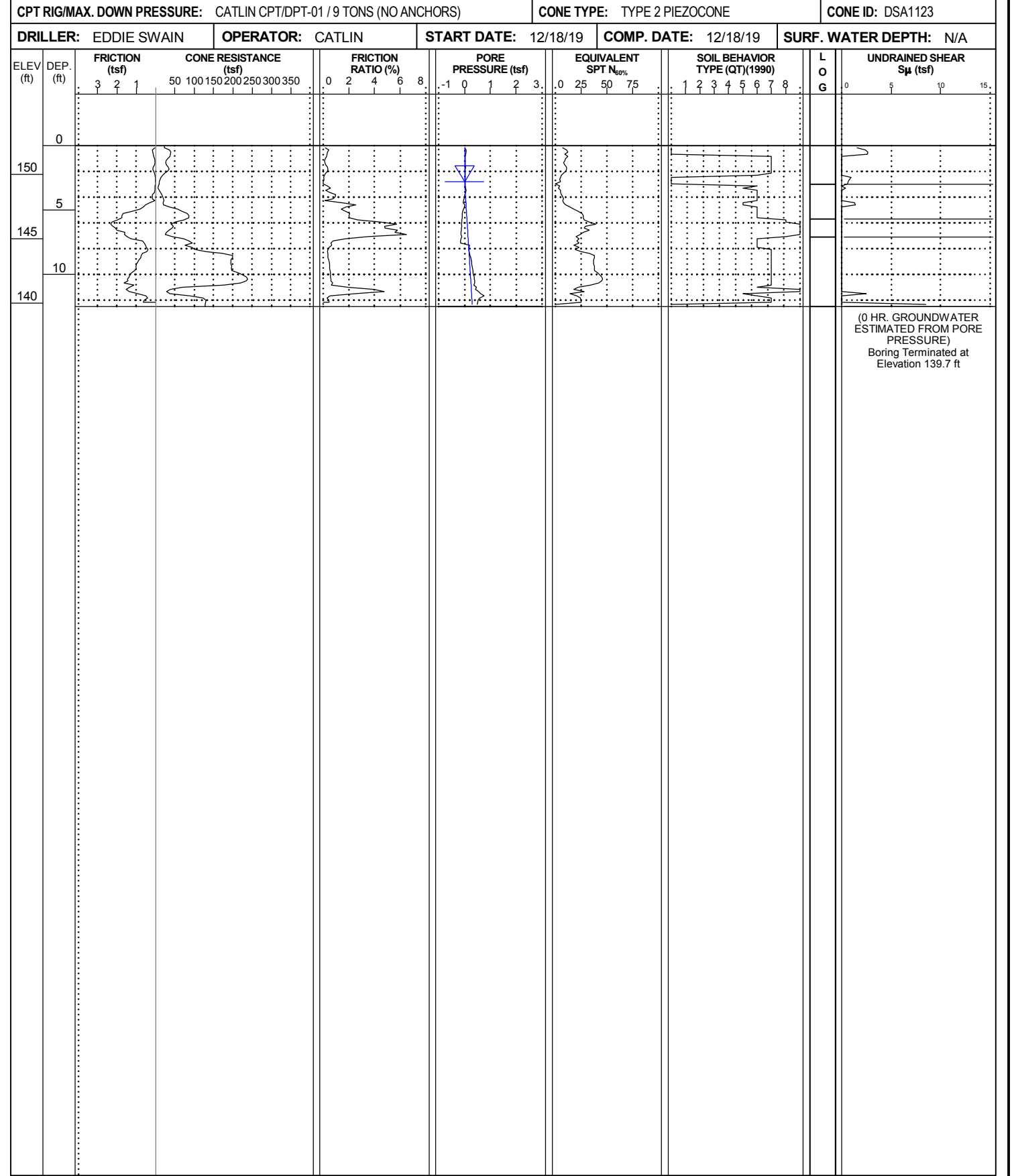

NCDOT CPT DOUBLE (PORTRAIT) NO-LITH 15987\_GEO\_ROWY\_CATLIN\_GTM-DRILLED\_REVISED.GPJ NCDOT\_CATLIN.GDT 07/30/20

# CONE PENETROMETER TEST BORING REPORT



WBS: 47533.1.1	TIP: I-5987A	COUNTY: ROBESON/CUMBERLAND	GEOLOGIST: S. HUDSON
SITE DESCRIPTION: I-95 CUMBERLAND/ROBESON COUNTIES FROM US 301 (EXIT 22) TO I-95 BUSINESS/US 301 (EXIT 40)			GROUND WTR (ft)
BORING NO.: L_39300_RT	STATION: 393+00	OFFSET: 82 ft RT	ALIGNMENT: -L-
COLLAR ELEV.: 151.4 ft	TOTAL DEPTH: 12.4 ft	NORTHING: 364,206	EASTING: 2,000,953
CPT RIG/MAX. DOWN PRESSURE: CATLIN CPT/DPT-01 / 9 TONS (NO ANCHORS)		CONE TYPE: TYPE 2 PIEZOCONE	
DRILLER: EDDIE SWAIN		OPERATOR: CATLIN	
START DATE: 12/18/19		COMP. DATE: 12/18/19	
SURF. WATER DEPTH: N/A			

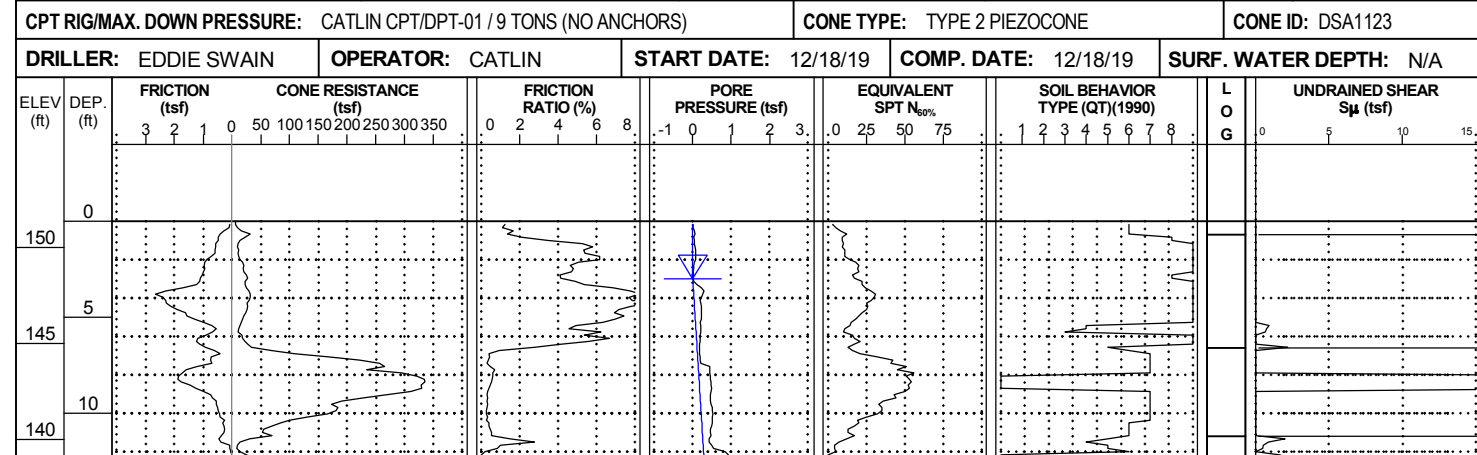

(0 HR. GROUNDWATER ESTIMATED FROM PORE PRESSURE)  
Boring Terminated at Elevation 139.0 ft

WBS: 47533.1.1	TIP: I-5987A	COUNTY: ROBESON/CUMBERLAND	GEOLOGIST: S. HUDSON
SITE DESCRIPTION: I-95 CUMBERLAND/ROBESON COUNTIES FROM US 301 (EXIT 22) TO I-95 BUSINESS/US 301 (EXIT 40)			GROUND WTR (ft)
BORING NO.: L_39800_RT	STATION: 398+00	OFFSET: 81 ft RT	ALIGNMENT: -L-
COLLAR ELEV.: 152.4 ft	TOTAL DEPTH: 12.4 ft	NORTHING: 364,706	EASTING: 2,000,957
CPT RIG/MAX. DOWN PRESSURE: CATLIN CPT/DPT-01 / 9 TONS (NO ANCHORS)		CONE TYPE: TYPE 2 PIEZOCONE	
DRILLER: EDDIE SWAIN		OPERATOR: CATLIN	
START DATE: 12/18/19		COMP. DATE: 12/18/19	
SURF. WATER DEPTH: N/A			

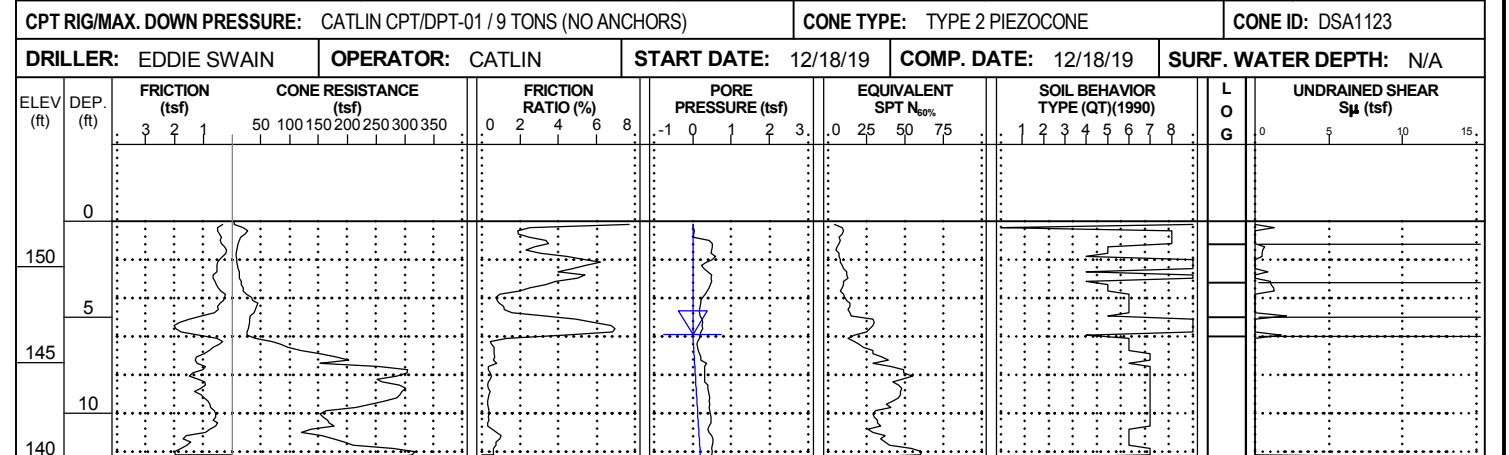

(0 HR. GROUNDWATER ESTIMATED FROM PORE PRESSURE)  
Boring Terminated at Elevation 140.0 ft

NCDOT CPT DOUBLE (PORTRAIT) NO-LITH 15987\_GEO\_RDWY\_CATLIN\_GTM-DRILLED\_REVISED.GPJ\_NCDOT\_CATLIN.GDT\_07/30/20

# CONE PENETROMETER TEST BORING REPORT



<b>WBS:</b> 47533.1.1	<b>TIP:</b> I-5987A	<b>COUNTY:</b> ROBESON/CUMBERLAND	<b>GEOLOGIST:</b> S. HUDSON
<b>SITE DESCRIPTION:</b> I-95 CUMBERLAND/ROBESON COUNTIES FROM US 301 (EXIT 22) TO I-95 BUSINESS/US 301 (EXIT 40)			<b>GROUND WTR (ft)</b>
<b>BORING NO.:</b> L_40200_RT	<b>STATION:</b> 402+00	<b>OFFSET:</b> 92 ft RT	<b>ALIGNMENT:</b> -L-
<b>COLLAR ELEV.:</b> 153.2 ft	<b>TOTAL DEPTH:</b> 14.3 ft	<b>NORTHING:</b> 365,106	<b>EASTING:</b> 2,000,971
<b>CPT RIG/MAX. DOWN PRESSURE:</b> CATLIN CPT/DPT-01 / 9 TONS (NO ANCHORS)		<b>CONE TYPE:</b> TYPE 2 PIEZOCONE	<b>CONE ID:</b> DSA1123
<b>DRILLER:</b> EDDIE SWAIN	<b>OPERATOR:</b> CATLIN	<b>START DATE:</b> 12/18/19	<b>COMP. DATE:</b> 12/18/19
		<b>SURF. WATER DEPTH:</b> N/A	

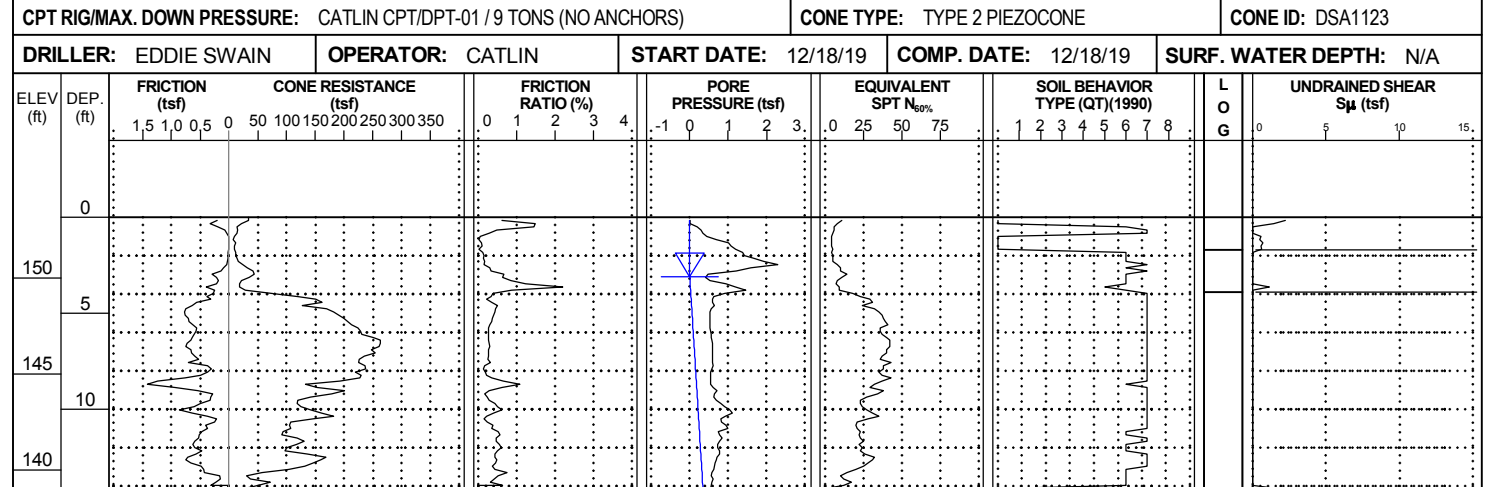

(0 HR. GROUNDWATER ESTIMATED FROM PORE PRESSURE)  
Boring Terminated at Elevation 138.9 ft

<b>WBS:</b> 47533.1.1	<b>TIP:</b> I-5987A	<b>COUNTY:</b> ROBESON/CUMBERLAND	<b>GEOLOGIST:</b> S. HUDSON
<b>SITE DESCRIPTION:</b> I-95 CUMBERLAND/ROBESON COUNTIES FROM US 301 (EXIT 22) TO I-95 BUSINESS/US 301 (EXIT 40)			<b>GROUND WTR (ft)</b>
<b>BORING NO.:</b> L_40700_LT	<b>STATION:</b> 407+00	<b>OFFSET:</b> 91 ft LT	<b>ALIGNMENT:</b> -L-
<b>COLLAR ELEV.:</b> 159.8 ft	<b>TOTAL DEPTH:</b> 10.1 ft	<b>NORTHING:</b> 365,608	<b>EASTING:</b> 2,000,792
<b>CPT RIG/MAX. DOWN PRESSURE:</b> CATLIN CPT/DPT-01 / 9 TONS (NO ANCHORS)		<b>CONE TYPE:</b> TYPE 2 PIEZOCONE	<b>CONE ID:</b> DSG0867
<b>DRILLER:</b> EDDIE SWAIN	<b>OPERATOR:</b> CATLIN	<b>START DATE:</b> 01/30/20	<b>COMP. DATE:</b> 01/30/20
		<b>SURF. WATER DEPTH:</b> N/A	

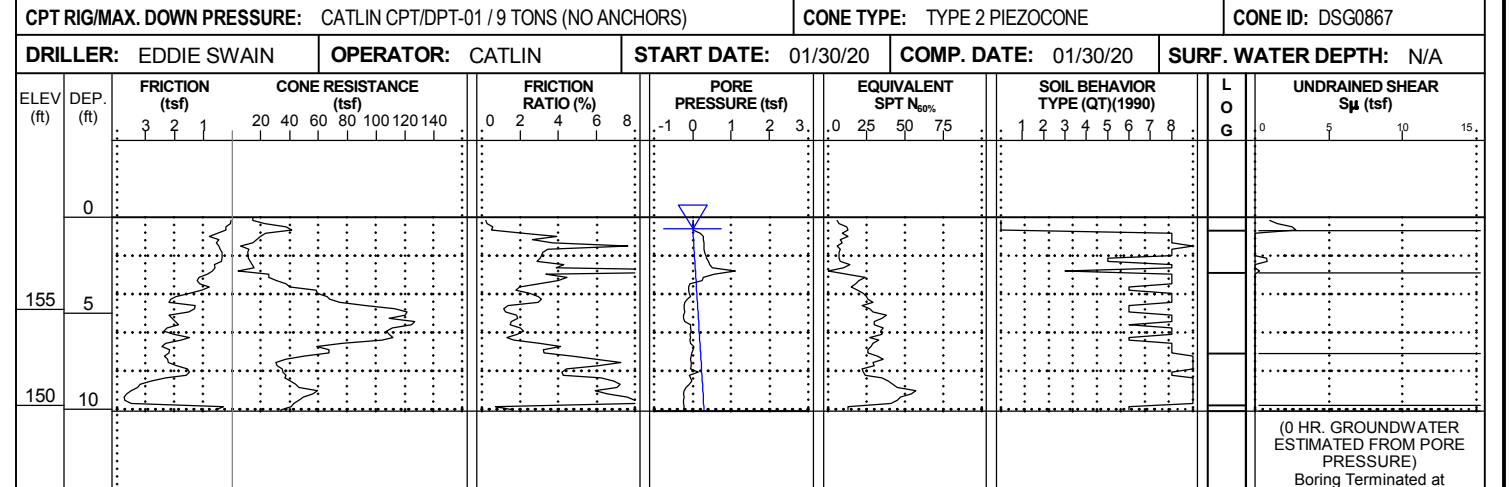

(0 HR. GROUNDWATER ESTIMATED FROM PORE PRESSURE)  
Boring Terminated at Elevation 149.7 ft

NCDOT CPT DOUBLE (PORTRAIT) NO-LITH 15987\_GEO\_ROWY\_CATLIN\_GTM-DRILLED\_REVISED.GPJ NCDOT\_CATLIN.GDT 07/30/20

# CONE PENETROMETER TEST BORING REPORT



<b>WBS:</b> 47533.1.1	<b>TIP:</b> I-5987A	<b>COUNTY:</b> ROBESON/CUMBERLAND	<b>GEOLOGIST:</b> S. HUDSON
<b>SITE DESCRIPTION:</b> I-95 CUMBERLAND/ROBESON COUNTIES FROM US 301 (EXIT 22) TO I-95 BUSINESS/US 301 (EXIT 40)			<b>GROUND WTR (ft)</b>
<b>BORING NO.:</b> L_41200_LT	<b>STATION:</b> 412+00	<b>OFFSET:</b> 75 ft LT	<b>ALIGNMENT:</b> -L-
<b>COLLAR ELEV.:</b> 158.5 ft	<b>TOTAL DEPTH:</b> 10.5 ft	<b>NORTHING:</b> 366,107	<b>EASTING:</b> 2,000,813
<b>CPT RIG/MAX. DOWN PRESSURE:</b> CATLIN CPT/DPT-01 / 9 TONS (NO ANCHORS)		<b>CONE TYPE:</b> TYPE 2 PIEZOCONE	<b>CONE ID:</b> DSG0867
<b>DRILLER:</b> EDDIE SWAIN	<b>OPERATOR:</b> CATLIN	<b>START DATE:</b> 01/30/20	<b>COMP. DATE:</b> 01/30/20
		<b>SURF. WATER DEPTH:</b> N/A	

<b>WBS:</b> 47533.1.1	<b>TIP:</b> I-5987A	<b>COUNTY:</b> ROBESON/CUMBERLAND	<b>GEOLOGIST:</b> S. HUDSON
<b>SITE DESCRIPTION:</b> I-95 CUMBERLAND/ROBESON COUNTIES FROM US 301 (EXIT 22) TO I-95 BUSINESS/US 301 (EXIT 40)			<b>GROUND WTR (ft)</b>
<b>BORING NO.:</b> L_41700_LT	<b>STATION:</b> 417+00	<b>OFFSET:</b> 73 ft LT	<b>ALIGNMENT:</b> -L-
<b>COLLAR ELEV.:</b> 157.1 ft	<b>TOTAL DEPTH:</b> 10.4 ft	<b>NORTHING:</b> 366,607	<b>EASTING:</b> 2,000,819
<b>CPT RIG/MAX. DOWN PRESSURE:</b> CATLIN CPT/DPT-01 / 9 TONS (NO ANCHORS)		<b>CONE TYPE:</b> TYPE 2 PIEZOCONE	<b>CONE ID:</b> DSG0867
<b>DRILLER:</b> EDDIE SWAIN	<b>OPERATOR:</b> CATLIN	<b>START DATE:</b> 01/30/20	<b>COMP. DATE:</b> 01/31/20
		<b>SURF. WATER DEPTH:</b> N/A	

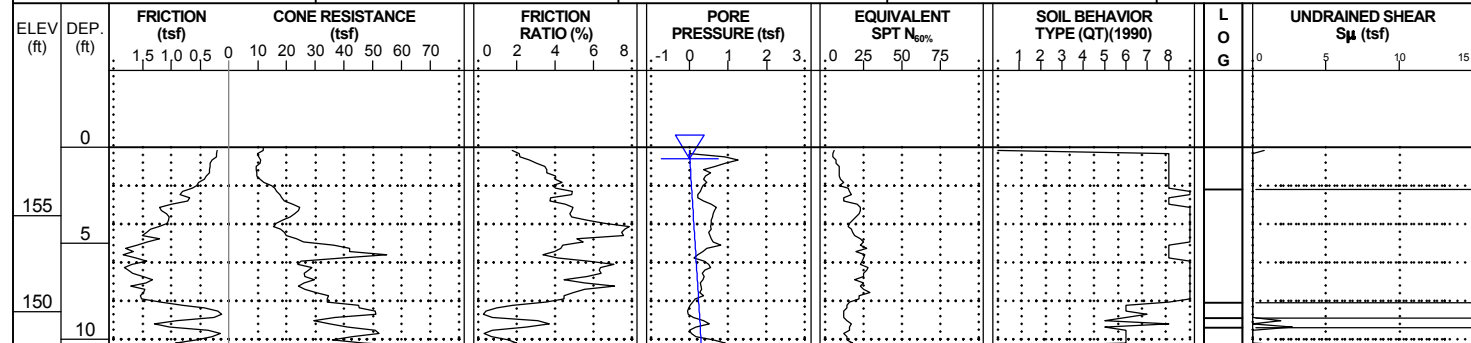

(0 HR. GROUNDWATER ESTIMATED FROM PORE PRESSURE)  
Boring Terminated at Elevation 148.0 ft

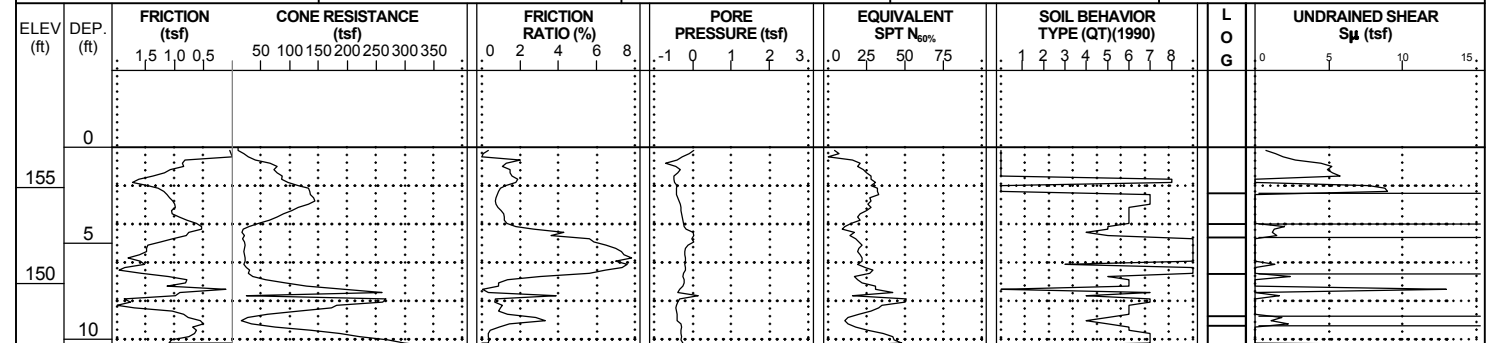

(0 HR. GROUNDWATER ESTIMATED FROM PORE PRESSURE)  
Boring Terminated at Elevation 146.7 ft  
  
PORE PRESSURE NOT CONDUSIVE TO ESTIMATING GROUND WATER - EST. GROUNDWATER SUSPECT

NCDOT CPT DOUBLE (PORTRAIT) NO-LITH 15987\_GEO\_ROWY\_CATLIN\_GTM-DRILLED\_REVISED.GPJ\_NCDOT\_CATLIN.GDT\_07/30/20



# CONE PENETROMETER TEST BORING REPORT



<b>WBS:</b> 47533.1.1	<b>TIP:</b> I-5987A	<b>COUNTY:</b> ROBESON/CUMBERLAND	<b>GEOLOGIST:</b> S. HUDSON
<b>SITE DESCRIPTION:</b> I-95 CUMBERLAND/ROBESON COUNTIES FROM US 301 (EXIT 22) TO I-95 BUSINESS/US 301 (EXIT 40)			<b>GROUND WTR (ft)</b>
<b>BORING NO.:</b> L_42200_LT	<b>STATION:</b> 422+00	<b>OFFSET:</b> 88 ft LT	<b>ALIGNMENT:</b> -L-
<b>COLLAR ELEV.:</b> 158.0 ft	<b>TOTAL DEPTH:</b> 12.4 ft	<b>NORTHING:</b> 367,107	<b>EASTING:</b> 2,000,808
<b>CPT RIG/MAX. DOWN PRESSURE:</b> CATLIN CPT/DPT-01 / 9 TONS (NO ANCHORS)		<b>CONE TYPE:</b> TYPE 2 PIEZOCONE	<b>CONE ID:</b> DSG0867
<b>DRILLER:</b> EDDIE SWAIN	<b>OPERATOR:</b> CATLIN	<b>START DATE:</b> 01/30/20	<b>COMP. DATE:</b> 01/31/20
<b>EST. 0 HR.</b> 10.9		<b>24 HR.</b> N/A	

<b>WBS:</b> 47533.1.1	<b>TIP:</b> I-5987A	<b>COUNTY:</b> ROBESON/CUMBERLAND	<b>GEOLOGIST:</b> S. HUDSON
<b>SITE DESCRIPTION:</b> I-95 CUMBERLAND/ROBESON COUNTIES FROM US 301 (EXIT 22) TO I-95 BUSINESS/US 301 (EXIT 40)			<b>GROUND WTR (ft)</b>
<b>BORING NO.:</b> L_42700_LT	<b>STATION:</b> 427+00	<b>OFFSET:</b> 89 ft LT	<b>ALIGNMENT:</b> -L-
<b>COLLAR ELEV.:</b> 157.5 ft	<b>TOTAL DEPTH:</b> 10.5 ft	<b>NORTHING:</b> 367,609	<b>EASTING:</b> 2,000,816
<b>CPT RIG/MAX. DOWN PRESSURE:</b> CATLIN CPT/DPT-01 / 9 TONS (NO ANCHORS)		<b>CONE TYPE:</b> TYPE 2 PIEZOCONE	<b>CONE ID:</b> DSG0867
<b>DRILLER:</b> EDDIE SWAIN	<b>OPERATOR:</b> CATLIN	<b>START DATE:</b> 01/30/20	<b>COMP. DATE:</b> 01/30/20
<b>EST. 0 HR.</b> 5.3		<b>24 HR.</b> N/A	

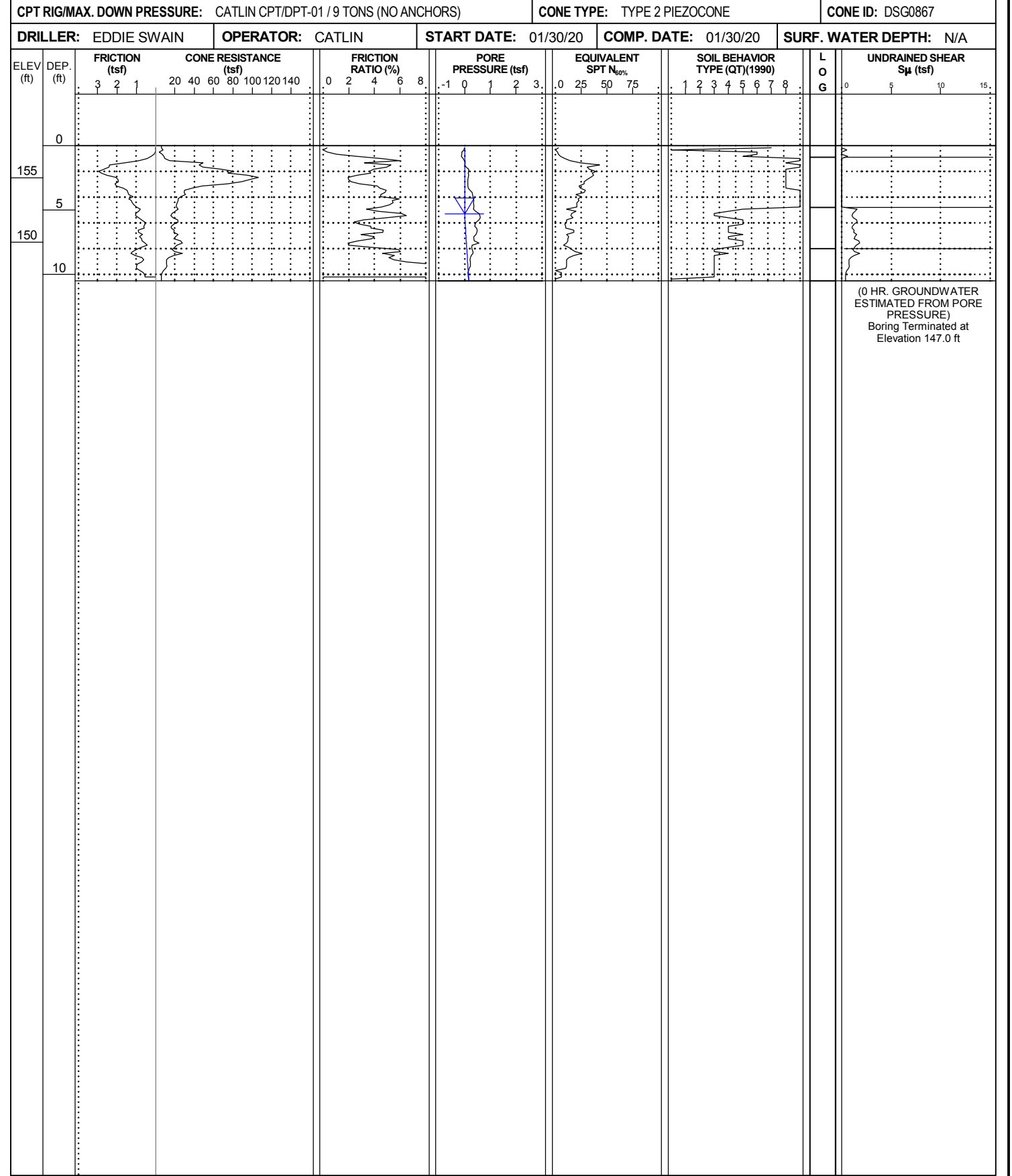
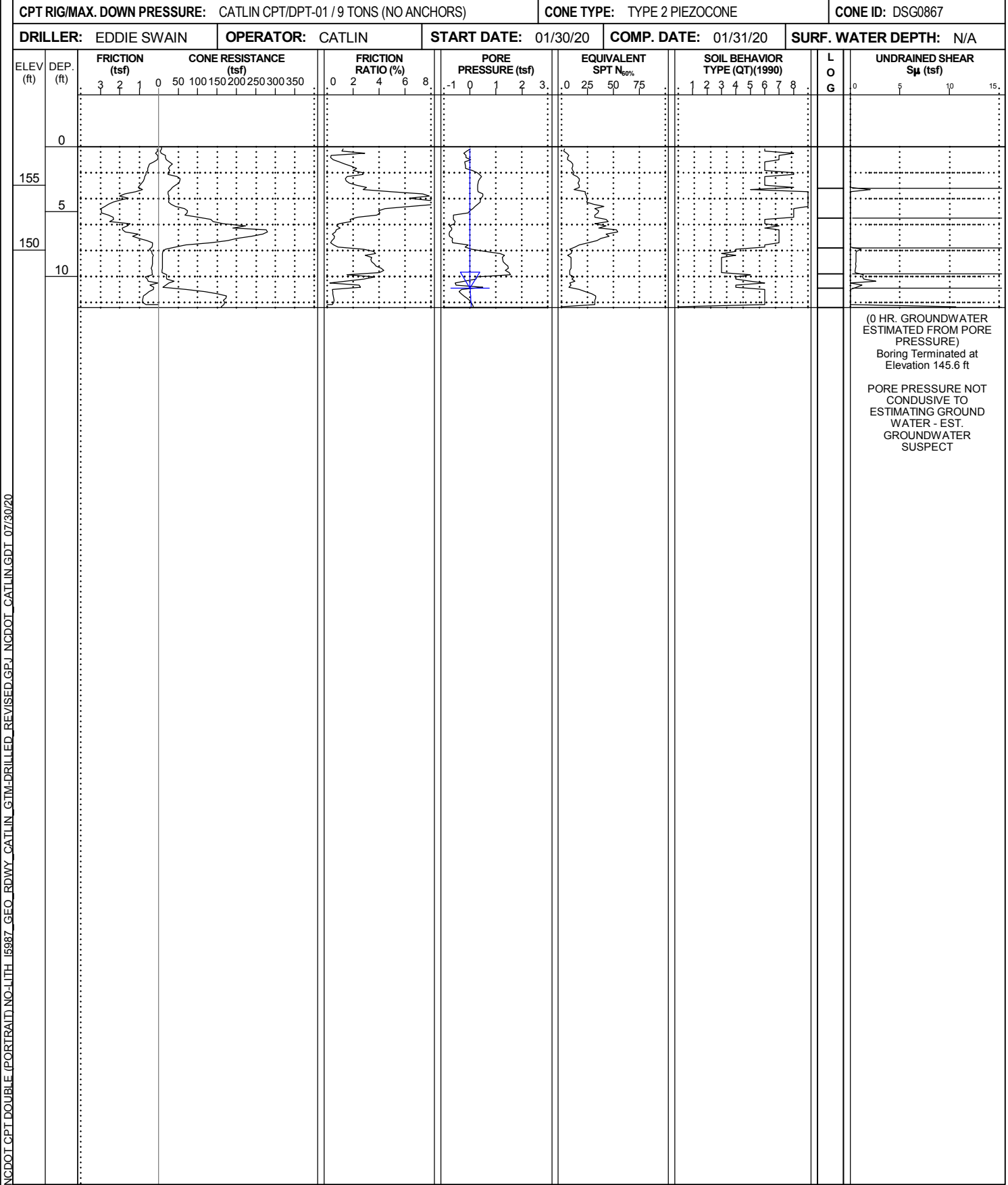

NCDOT CPT DOUBLE (PORTRAIT) NO-LITH 15987\_GEO\_ROWY\_CATLIN\_GTM-DRILLED\_REVISED.GPJ NCDOT\_CATLIN.GDT 07/30/20

# CONE PENETROMETER TEST BORING REPORT



WBS: 47533.1.1	TIP: I-5987A	COUNTY: ROBESON/CUMBERLAND	GEOLOGIST: S. HUDSON
SITE DESCRIPTION: I-95 CUMBERLAND/ROBESON COUNTIES FROM US 301 (EXIT 22) TO I-95 BUSINESS/US 301 (EXIT 40)			GROUND WTR (ft)
BORING NO.: L_43200_LT	STATION: 432+00	OFFSET: 90 ft LT	ALIGNMENT: -L-
COLLAR ELEV.: 159.1 ft	TOTAL DEPTH: 10.4 ft	NORTHING: 368,110	EASTING: 2,000,833
CPT RIG/MAX. DOWN PRESSURE: CATLIN CPT/DPT-01 / 9 TONS (NO ANCHORS)		CONE TYPE: TYPE 2 PIEZOCONE	
DRILLER: EDDIE SWAIN		OPERATOR: CATLIN	
START DATE: 01/30/20		COMP. DATE: 01/31/20	
SURF. WATER DEPTH: N/A			

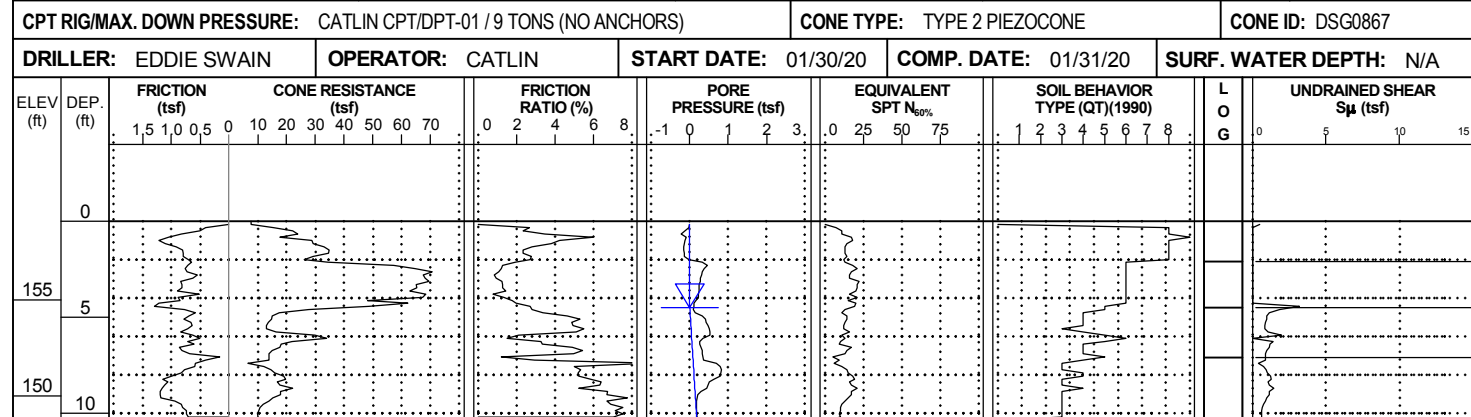

(0 HR. GROUNDWATER ESTIMATED FROM PORE PRESSURE)  
Boring Terminated at Elevation 148.7 ft

WBS: 47533.1.1	TIP: I-5987A	COUNTY: ROBESON/CUMBERLAND	GEOLOGIST: S. HUDSON
SITE DESCRIPTION: I-95 CUMBERLAND/ROBESON COUNTIES FROM US 301 (EXIT 22) TO I-95 BUSINESS/US 301 (EXIT 40)			GROUND WTR (ft)
BORING NO.: L_43700_LT	STATION: 437+00	OFFSET: 89 ft LT	ALIGNMENT: -L-
COLLAR ELEV.: 160.4 ft	TOTAL DEPTH: 10.3 ft	NORTHING: 368,611	EASTING: 2,000,861
CPT RIG/MAX. DOWN PRESSURE: CATLIN CPT/DPT-01 / 9 TONS (NO ANCHORS)		CONE TYPE: TYPE 2 PIEZOCONE	
DRILLER: EDDIE SWAIN		OPERATOR: CATLIN	
START DATE: 01/30/20		COMP. DATE: 01/31/20	
SURF. WATER DEPTH: N/A			

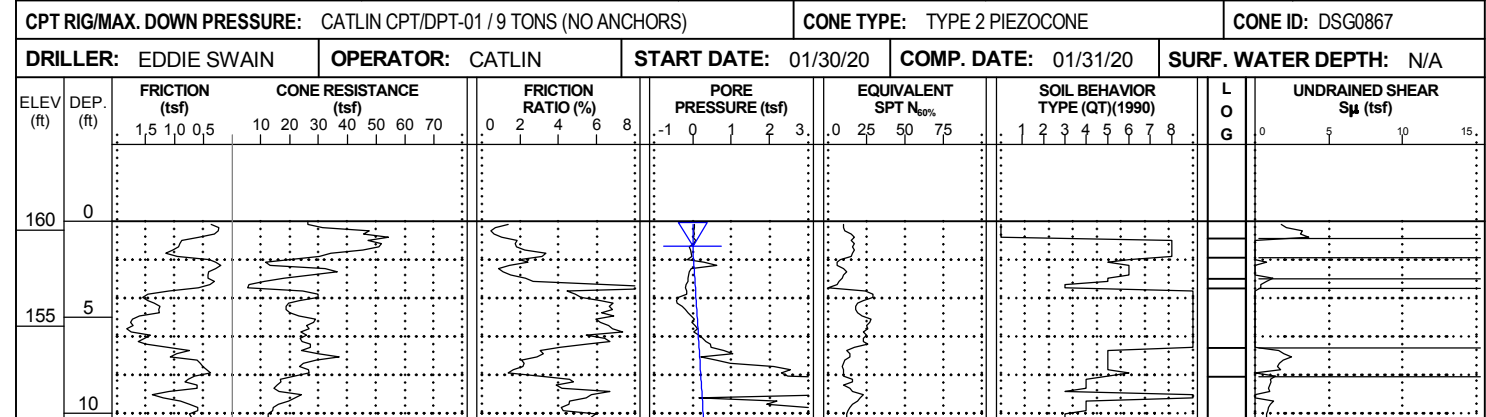

(0 HR. GROUNDWATER ESTIMATED FROM PORE PRESSURE)  
Boring Terminated at Elevation 150.1 ft

NCDOI CPT DOUBLE (PORTRAIT) NO-LITH 15987\_GEO\_ROWY\_CATLIN\_GTM-DRILLED\_REVISED.GPJ\_NCDOT\_CATLIN.GDT\_07/30/20

# CONE PENETROMETER TEST BORING REPORT



<b>WBS:</b> 47533.1.1	<b>TIP:</b> I-5987A	<b>COUNTY:</b> ROBESON/CUMBERLAND	<b>GEOLOGIST:</b> S. HUDSON
<b>SITE DESCRIPTION:</b> I-95 CUMBERLAND/ROBESON COUNTIES FROM US 301 (EXIT 22) TO I-95 BUSINESS/US 301 (EXIT 40)			<b>GROUND WTR (ft)</b>
<b>BORING NO.:</b> L_44200_RT	<b>STATION:</b> 442+00	<b>OFFSET:</b> 91 ft RT	<b>ALIGNMENT:</b> -L-
<b>COLLAR ELEV.:</b> 160.6 ft	<b>TOTAL DEPTH:</b> 10.2 ft	<b>NORTHING:</b> 369,098	<b>EASTING:</b> 2,001,075
<b>CPT RIG/MAX. DOWN PRESSURE:</b> CATLIN CPT/DPT-01 / 9 TONS (NO ANCHORS)		<b>CONE TYPE:</b> TYPE 2 PIEZOcone	<b>CONE ID:</b> DSA1123
<b>DRILLER:</b> EDDIE SWAIN	<b>OPERATOR:</b> CATLIN	<b>START DATE:</b> 12/18/19	<b>COMP. DATE:</b> 12/18/19
<b>EST. 0 HR.</b> 1.3		<b>24 HR.</b> N/A	

<b>WBS:</b> 47533.1.1	<b>TIP:</b> I-5987A	<b>COUNTY:</b> ROBESON/CUMBERLAND	<b>GEOLOGIST:</b> S. HUDSON
<b>SITE DESCRIPTION:</b> I-95 CUMBERLAND/ROBESON COUNTIES FROM US 301 (EXIT 22) TO I-95 BUSINESS/US 301 (EXIT 40)			<b>GROUND WTR (ft)</b>
<b>BORING NO.:</b> L_44700_RT	<b>STATION:</b> 447+00	<b>OFFSET:</b> 92 ft RT	<b>ALIGNMENT:</b> -L-
<b>COLLAR ELEV.:</b> 160.7 ft	<b>TOTAL DEPTH:</b> 8.9 ft	<b>NORTHING:</b> 369,597	<b>EASTING:</b> 2,001,111
<b>CPT RIG/MAX. DOWN PRESSURE:</b> CATLIN CPT/DPT-01 / 9 TONS (NO ANCHORS)		<b>CONE TYPE:</b> TYPE 2 PIEZOcone	<b>CONE ID:</b> DSA1123
<b>DRILLER:</b> EDDIE SWAIN	<b>OPERATOR:</b> CATLIN	<b>START DATE:</b> 12/18/19	<b>COMP. DATE:</b> 12/18/19
<b>EST. 0 HR.</b> 0.6		<b>24 HR.</b> N/A	

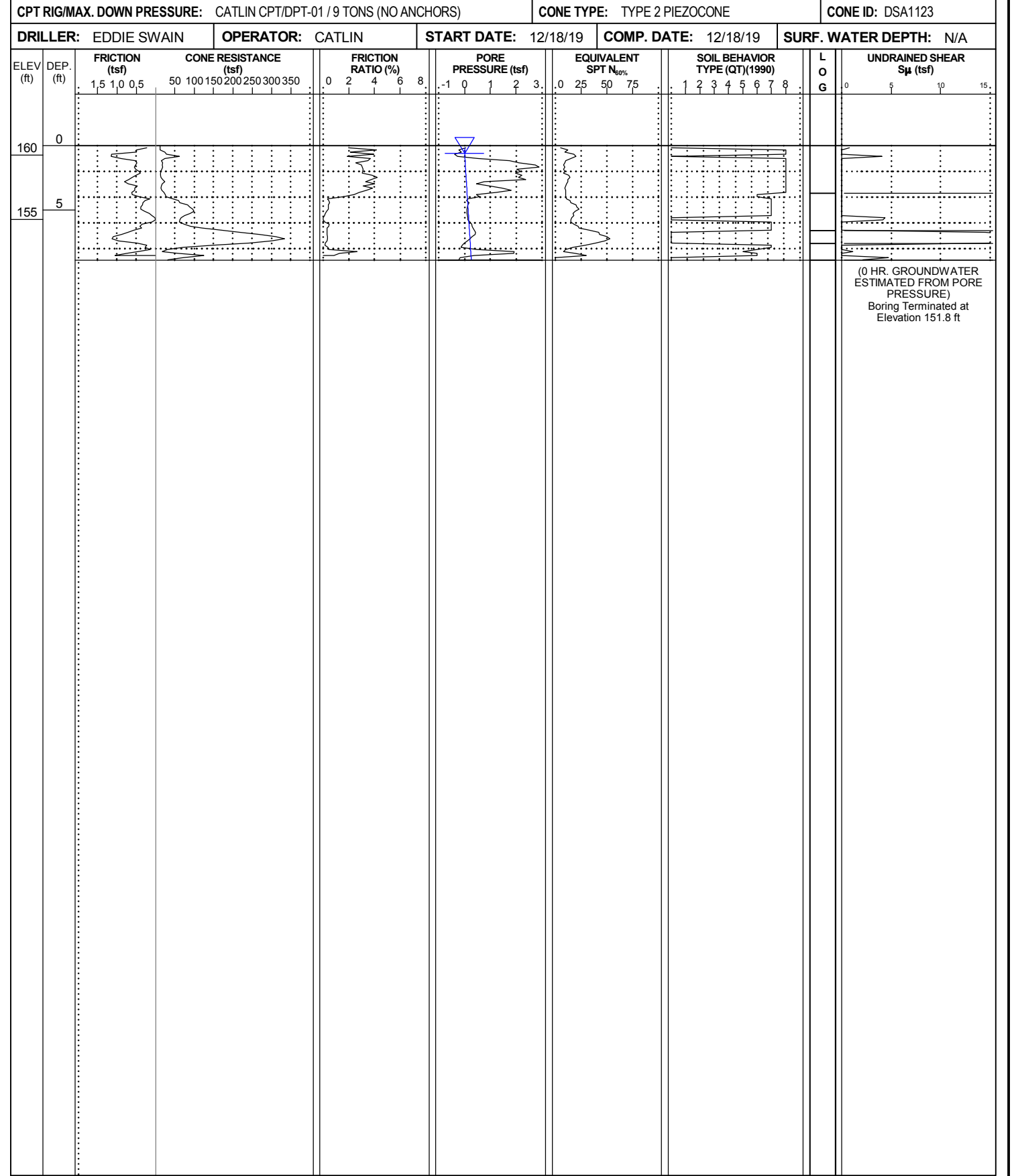
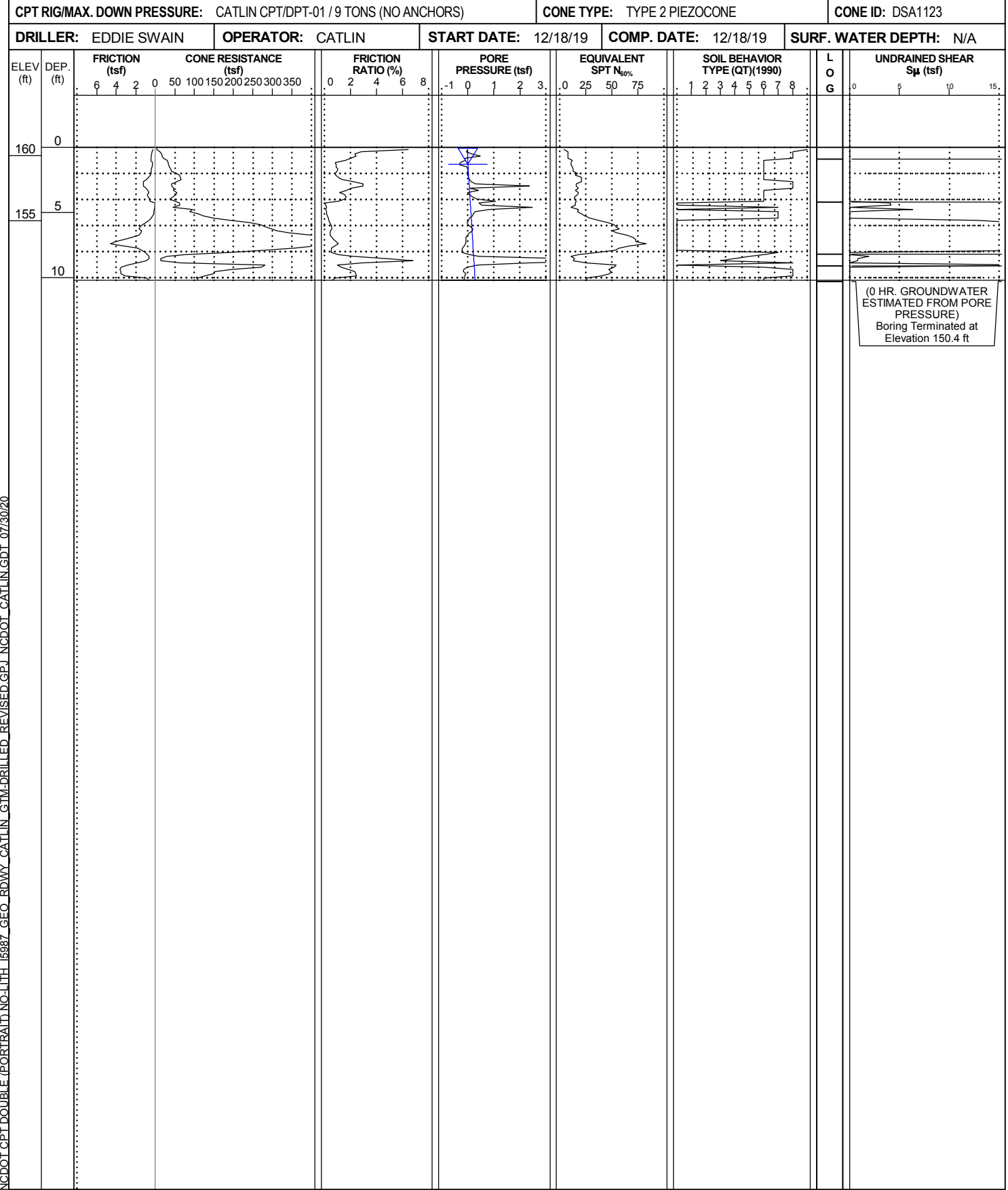

NCDOT CPT DOUBLE (PORTRAIT) NO-LITH 15987\_GEO\_RDWY\_CATLIN\_GTM-DRILLED\_REVISED.GPJ NCDOT\_CATLIN.GDT 07/30/20

# CONE PENETROMETER TEST BORING REPORT



<b>WBS:</b> 47533.1.1	<b>TIP:</b> I-5987A	<b>COUNTY:</b> ROBESON/CUMBERLAND	<b>GEOLOGIST:</b> S. HUDSON
<b>SITE DESCRIPTION:</b> I-95 CUMBERLAND/ROBESON COUNTIES FROM US 301 (EXIT 22) TO I-95 BUSINESS/US 301 (EXIT 40)			<b>GROUND WTR (ft)</b>
<b>BORING NO.:</b> L_46700	<b>STATION:</b> 467+00	<b>OFFSET:</b> 2 ft RT	<b>ALIGNMENT:</b> -L-
<b>COLLAR ELEV.:</b> 165.3 ft	<b>TOTAL DEPTH:</b> 8.3 ft	<b>NORTHING:</b> 371,598	<b>EASTING:</b> 2,001,162
<b>CPT RIG/MAX. DOWN PRESSURE:</b> CATLIN CPT/DPT-01 / 9 TONS (NO ANCHORS)		<b>CONE TYPE:</b> TYPE 2 PIEZOCONE	<b>CONE ID:</b> DSG0867
<b>DRILLER:</b> EDDIE SWAIN	<b>OPERATOR:</b> CATLIN	<b>START DATE:</b> 01/29/20	<b>COMP. DATE:</b> 01/29/20
<b>EST. 0 HR.</b> 2.1		<b>24 HR.</b> N/A	

<b>WBS:</b> 47533.1.1	<b>TIP:</b> I-5987A	<b>COUNTY:</b> ROBESON/CUMBERLAND	<b>GEOLOGIST:</b> S. HUDSON
<b>SITE DESCRIPTION:</b> I-95 CUMBERLAND/ROBESON COUNTIES FROM US 301 (EXIT 22) TO I-95 BUSINESS/US 301 (EXIT 40)			<b>GROUND WTR (ft)</b>
<b>BORING NO.:</b> L_47200	<b>STATION:</b> 472+00	<b>OFFSET:</b> 2 ft RT	<b>ALIGNMENT:</b> -L-
<b>COLLAR ELEV.:</b> 166.0 ft	<b>TOTAL DEPTH:</b> 10.4 ft	<b>NORTHING:</b> 372,097	<b>EASTING:</b> 2,001,198
<b>CPT RIG/MAX. DOWN PRESSURE:</b> CATLIN CPT/DPT-01 / 9 TONS (NO ANCHORS)		<b>CONE TYPE:</b> TYPE 2 PIEZOCONE	<b>CONE ID:</b> DSG0867
<b>DRILLER:</b> EDDIE SWAIN	<b>OPERATOR:</b> CATLIN	<b>START DATE:</b> 01/29/20	<b>COMP. DATE:</b> 01/29/20
<b>EST. 0 HR.</b> 3.7		<b>24 HR.</b> N/A	

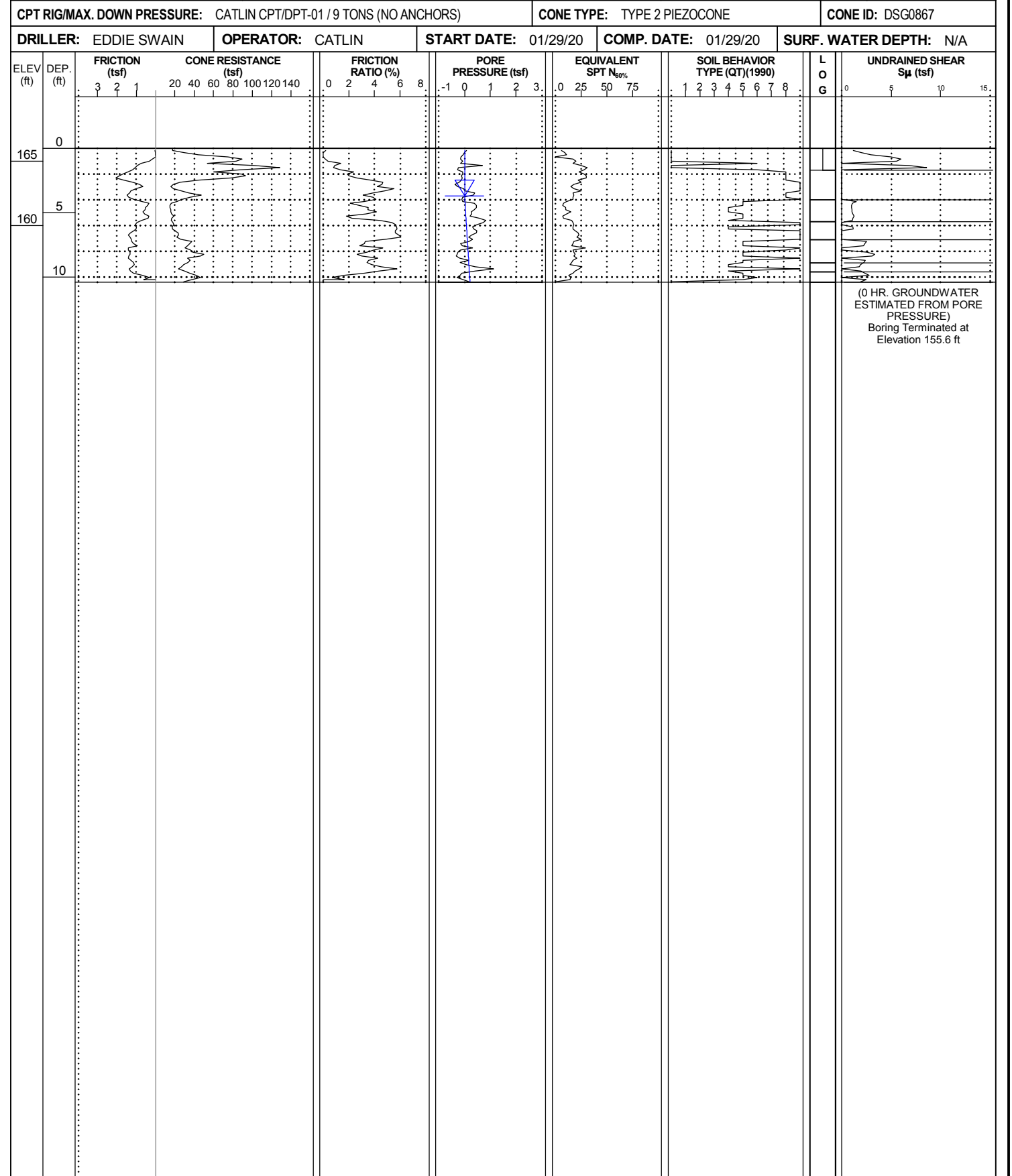
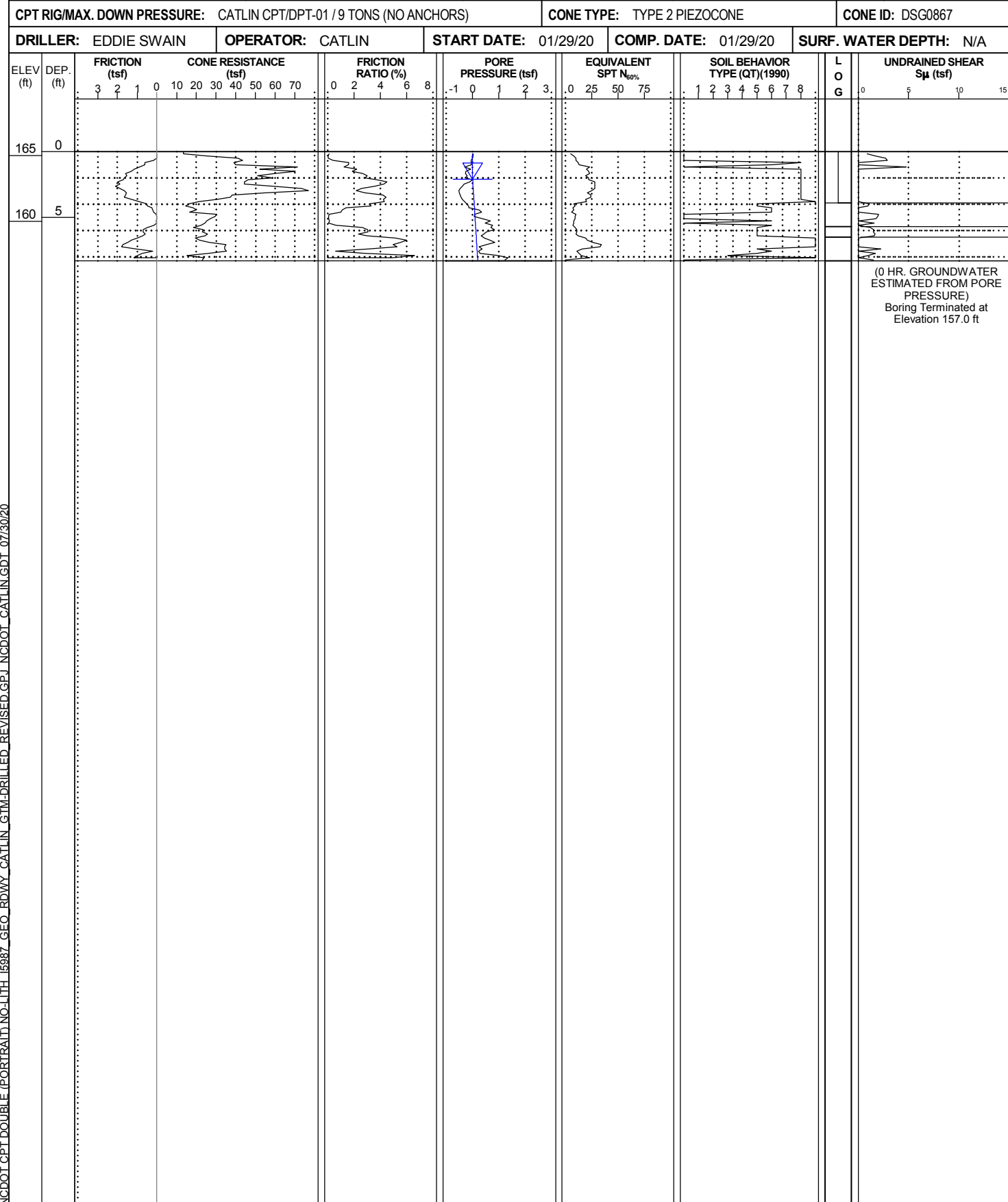

NCDOT CPT DOUBLE (PORTRAIT) NO-LITH 15987\_GEO\_RDWY\_CATLIN\_GTM-DRILLED\_REVISED.GPJ NCDOT\_CATLIN.GDT 07/30/20

# CONE PENETROMETER TEST BORING REPORT



<b>WBS:</b> 47533.1.1	<b>TIP:</b> I-5987A	<b>COUNTY:</b> ROBESON/CUMBERLAND	<b>GEOLOGIST:</b> S. HUDSON
<b>SITE DESCRIPTION:</b> I-95 CUMBERLAND/ROBESON COUNTIES FROM US 301 (EXIT 22) TO I-95 BUSINESS/US 301 (EXIT 40)			<b>GROUND WTR (ft)</b>
<b>BORING NO.:</b> L_47700	<b>STATION:</b> 477+01	<b>OFFSET:</b> 2 ft RT	<b>ALIGNMENT:</b> -L-
<b>COLLAR ELEV.:</b> 166.4 ft	<b>TOTAL DEPTH:</b> 10.5 ft	<b>NORTHING:</b> 372,596	<b>EASTING:</b> 2,001,233
<b>CPT RIG/MAX. DOWN PRESSURE:</b> CATLIN CPT/DPT-01 / 9 TONS (NO ANCHORS)		<b>CONE TYPE:</b> TYPE 2 PIEZOCONE	<b>CONE ID:</b> DSG0867
<b>DRILLER:</b> EDDIE SWAIN	<b>OPERATOR:</b> CATLIN	<b>START DATE:</b> 01/29/20	<b>COMP. DATE:</b> 01/29/20
		<b>SURF. WATER DEPTH:</b> N/A	

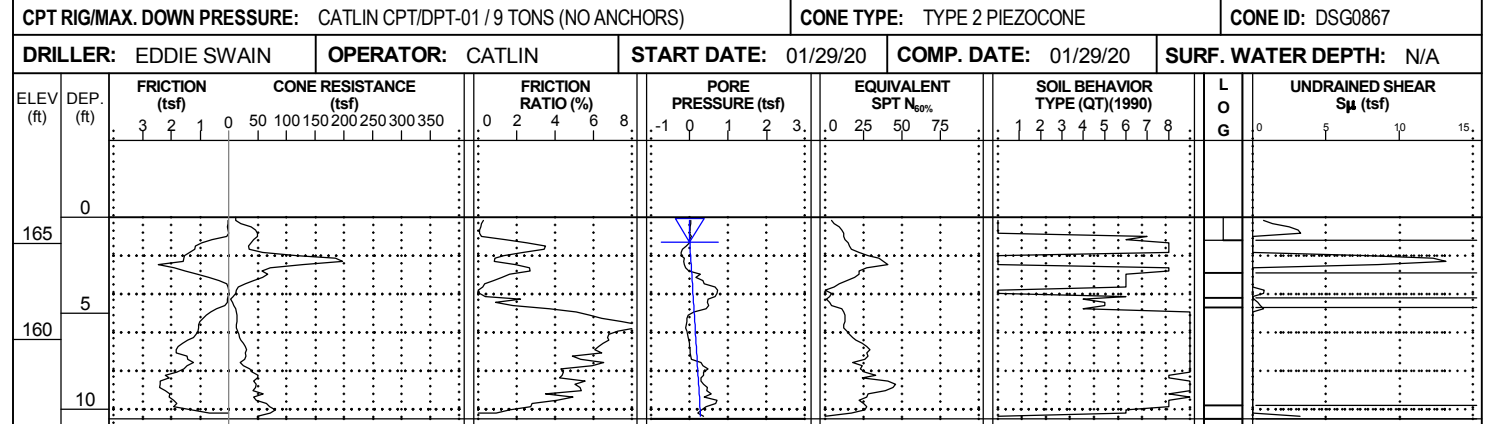

(0 HR. GROUNDWATER ESTIMATED FROM PORE PRESSURE)  
Boring Terminated at Elevation 155.9 ft

<b>WBS:</b> 47533.1.1	<b>TIP:</b> I-5987A	<b>COUNTY:</b> ROBESON/CUMBERLAND	<b>GEOLOGIST:</b> S. HUDSON
<b>SITE DESCRIPTION:</b> I-95 CUMBERLAND/ROBESON COUNTIES FROM US 301 (EXIT 22) TO I-95 BUSINESS/US 301 (EXIT 40)			<b>GROUND WTR (ft)</b>
<b>BORING NO.:</b> L_48200	<b>STATION:</b> 482+00	<b>OFFSET:</b> 2 ft RT	<b>ALIGNMENT:</b> -L-
<b>COLLAR ELEV.:</b> 166.6 ft	<b>TOTAL DEPTH:</b> 10.5 ft	<b>NORTHING:</b> 373,094	<b>EASTING:</b> 2,001,268
<b>CPT RIG/MAX. DOWN PRESSURE:</b> CATLIN CPT/DPT-01 / 9 TONS (NO ANCHORS)		<b>CONE TYPE:</b> TYPE 2 PIEZOCONE	<b>CONE ID:</b> DSG0867
<b>DRILLER:</b> EDDIE SWAIN	<b>OPERATOR:</b> CATLIN	<b>START DATE:</b> 01/29/20	<b>COMP. DATE:</b> 01/29/20
		<b>SURF. WATER DEPTH:</b> N/A	

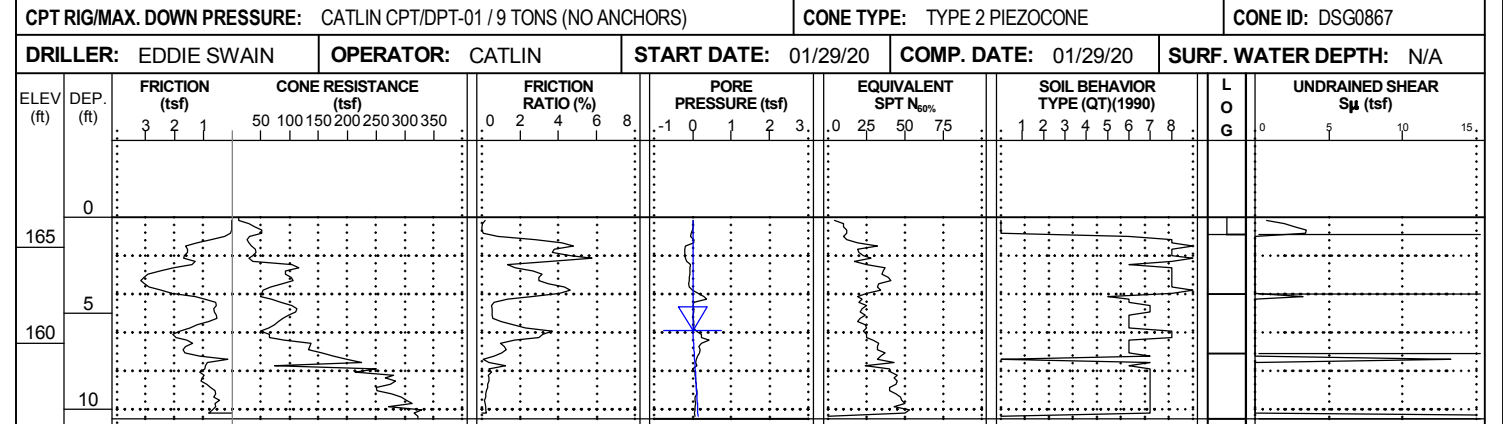

(0 HR. GROUNDWATER ESTIMATED FROM PORE PRESSURE)  
Boring Terminated at Elevation 156.1 ft

NCDOT CPT DOUBLE (PORTRAIT) NO-LITH 15987\_GEO\_ROWY\_CATLIN\_GTM-DRILLED\_REVISED.GPJ NCDOT\_CATLIN.GDT 07/30/20

# CONE PENETROMETER TEST BORING REPORT



<b>WBS:</b> 47533.1.1	<b>TIP:</b> I-5987A	<b>COUNTY:</b> ROBESON/CUMBERLAND	<b>GEOLOGIST:</b> S. HUDSON
<b>SITE DESCRIPTION:</b> I-95 CUMBERLAND/ROBESON COUNTIES FROM US 301 (EXIT 22) TO I-95 BUSINESS/US 301 (EXIT 40)			<b>GROUND WTR (ft)</b>
<b>BORING NO.:</b> L_48700	<b>STATION:</b> 487+00	<b>OFFSET:</b> 2 ft RT	<b>ALIGNMENT:</b> -L-
<b>COLLAR ELEV.:</b> 166.1 ft	<b>TOTAL DEPTH:</b> 10.5 ft	<b>NORTHING:</b> 373,593	<b>EASTING:</b> 2,001,304
<b>CPT RIG/MAX. DOWN PRESSURE:</b> CATLIN CPT/DPT-01 / 9 TONS (NO ANCHORS)		<b>CONE TYPE:</b> TYPE 2 PIEZOCONE	<b>CONE ID:</b> DSG0867
<b>DRILLER:</b> EDDIE SWAIN	<b>OPERATOR:</b> CATLIN	<b>START DATE:</b> 01/29/20	<b>COMP. DATE:</b> 01/29/20
		<b>SURF. WATER DEPTH:</b> N/A	

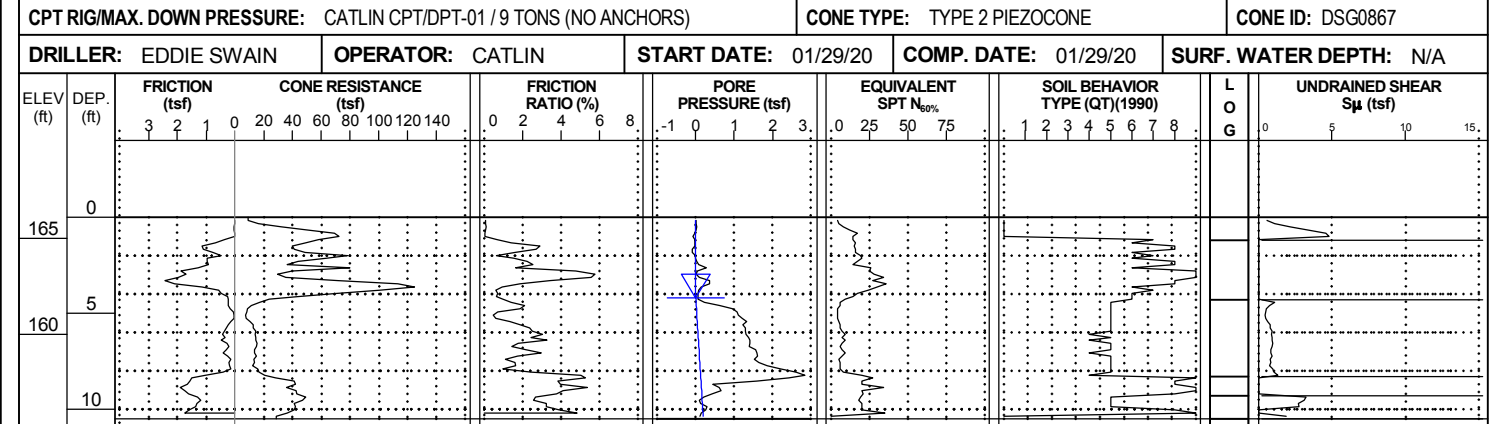

(0 HR. GROUNDWATER ESTIMATED FROM PORE PRESSURE)  
Boring Terminated at Elevation 155.6 ft

<b>WBS:</b> 47533.1.1	<b>TIP:</b> I-5987A	<b>COUNTY:</b> ROBESON/CUMBERLAND	<b>GEOLOGIST:</b> S. HUDSON
<b>SITE DESCRIPTION:</b> I-95 CUMBERLAND/ROBESON COUNTIES FROM US 301 (EXIT 22) TO I-95 BUSINESS/US 301 (EXIT 40)			<b>GROUND WTR (ft)</b>
<b>BORING NO.:</b> L_49200	<b>STATION:</b> 492+00	<b>OFFSET:</b> 2 ft RT	<b>ALIGNMENT:</b> -L-
<b>COLLAR ELEV.:</b> 165.8 ft	<b>TOTAL DEPTH:</b> 10.5 ft	<b>NORTHING:</b> 374,092	<b>EASTING:</b> 2,001,339
<b>CPT RIG/MAX. DOWN PRESSURE:</b> CATLIN CPT/DPT-01 / 9 TONS (NO ANCHORS)		<b>CONE TYPE:</b> TYPE 2 PIEZOCONE	<b>CONE ID:</b> DSG0867
<b>DRILLER:</b> EDDIE SWAIN	<b>OPERATOR:</b> CATLIN	<b>START DATE:</b> 01/29/20	<b>COMP. DATE:</b> 01/29/20
		<b>SURF. WATER DEPTH:</b> N/A	

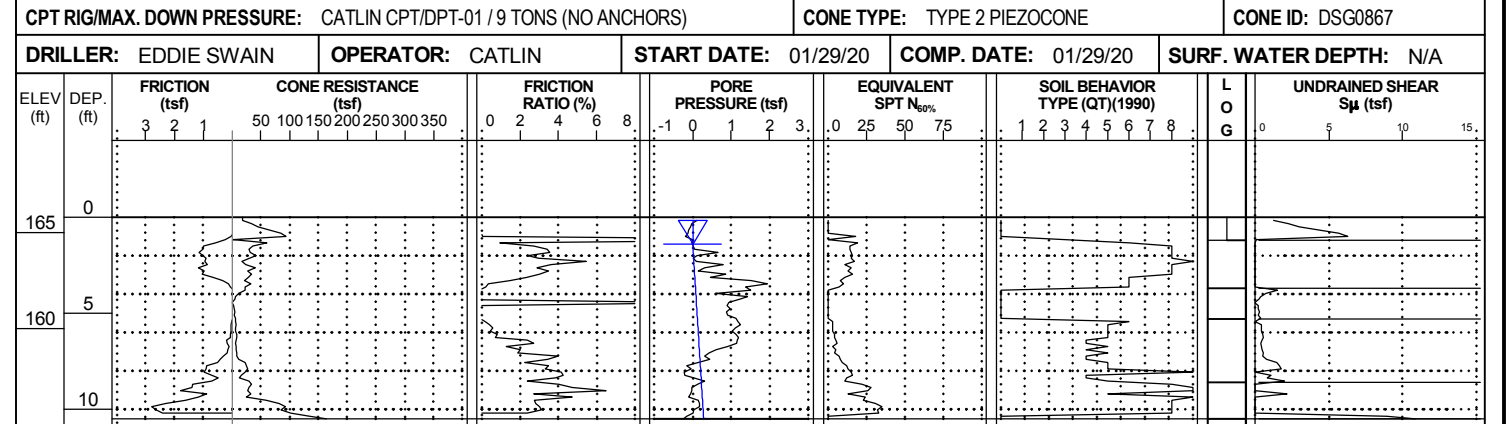

(0 HR. GROUNDWATER ESTIMATED FROM PORE PRESSURE)  
Boring Terminated at Elevation 155.3 ft

NCDOT CPT DOUBLE (PORTRAIT) NO-LITH 15987\_GEO\_ROWY\_CATLIN\_GTM-DRILLED\_REVISED.GPJ NCDOT\_CATLIN.GDT 07/30/20

# CONE PENETROMETER TEST BORING REPORT



<b>WBS:</b> 47533.1.1	<b>TIP:</b> I-5987A	<b>COUNTY:</b> ROBESON/CUMBERLAND	<b>GEOLOGIST:</b> S. HUDSON
<b>SITE DESCRIPTION:</b> I-95 CUMBERLAND/ROBESON COUNTIES FROM US 301 (EXIT 22) TO I-95 BUSINESS/US 301 (EXIT 40)			<b>GROUND WTR (ft)</b>
<b>BORING NO.:</b> Y1ARPA_1100	<b>STATION:</b> 11+86	<b>OFFSET:</b> 44 ft RT	<b>ALIGNMENT:</b> -Y1ARPA-
<b>COLLAR ELEV.:</b> 151.3 ft	<b>TOTAL DEPTH:</b> 10.4 ft	<b>NORTHING:</b> 355,312	<b>EASTING:</b> 2,000,682
<b>CPT RIG/MAX. DOWN PRESSURE:</b> CATLIN CPT/DPT-01 / 9 TONS (NO ANCHORS)		<b>CONE TYPE:</b> TYPE 2 PIEZOCONE	<b>CONE ID:</b> DSG0867
<b>DRILLER:</b> EDDIE SWAIN	<b>OPERATOR:</b> CATLIN	<b>START DATE:</b> 01/30/20	<b>COMP. DATE:</b> 01/31/20
		<b>SURF. WATER DEPTH:</b> N/A	

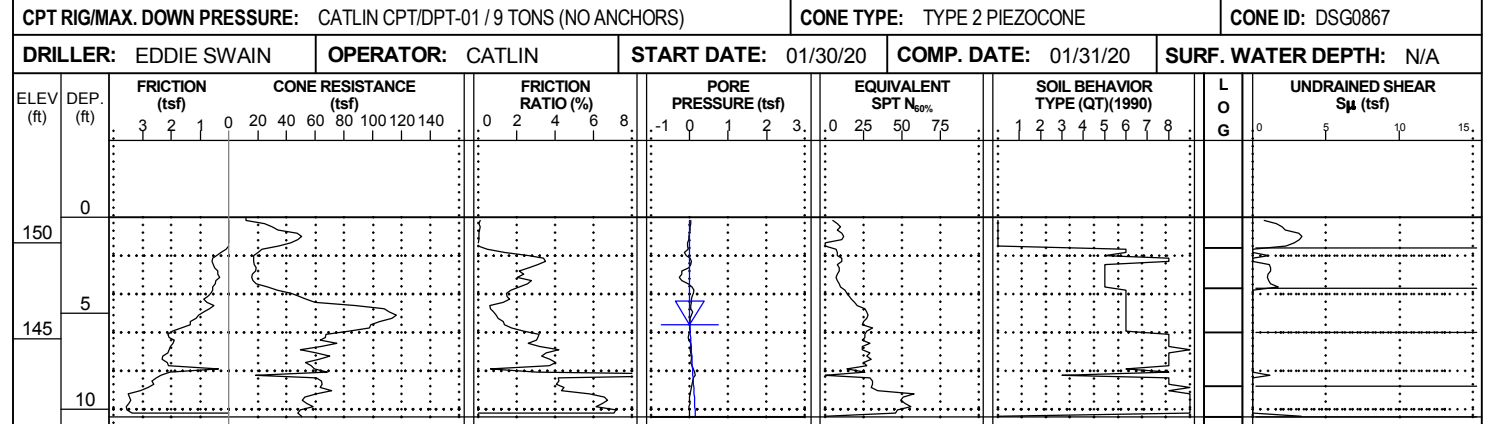

(0 HR. GROUNDWATER ESTIMATED FROM PORE PRESSURE)  
Boring Terminated at Elevation 140.9 ft

<b>WBS:</b> 47533.1.1	<b>TIP:</b> I-5987A	<b>COUNTY:</b> ROBESON/CUMBERLAND	<b>GEOLOGIST:</b> S. HUDSON
<b>SITE DESCRIPTION:</b> I-95 CUMBERLAND/ROBESON COUNTIES FROM US 301 (EXIT 22) TO I-95 BUSINESS/US 301 (EXIT 40)			<b>GROUND WTR (ft)</b>
<b>BORING NO.:</b> Y1ARPA_1550	<b>STATION:</b> 16+37	<b>OFFSET:</b> 7 ft LT	<b>ALIGNMENT:</b> -Y1ARPA-
<b>COLLAR ELEV.:</b> 151.4 ft	<b>TOTAL DEPTH:</b> 12.4 ft	<b>NORTHING:</b> 354,860	<b>EASTING:</b> 2,000,687
<b>CPT RIG/MAX. DOWN PRESSURE:</b> CATLIN CPT/DPT-01 / 9 TONS (NO ANCHORS)		<b>CONE TYPE:</b> TYPE 2 PIEZOCONE	<b>CONE ID:</b> DSG0867
<b>DRILLER:</b> EDDIE SWAIN	<b>OPERATOR:</b> CATLIN	<b>START DATE:</b> 01/30/20	<b>COMP. DATE:</b> 01/31/20
		<b>SURF. WATER DEPTH:</b> N/A	

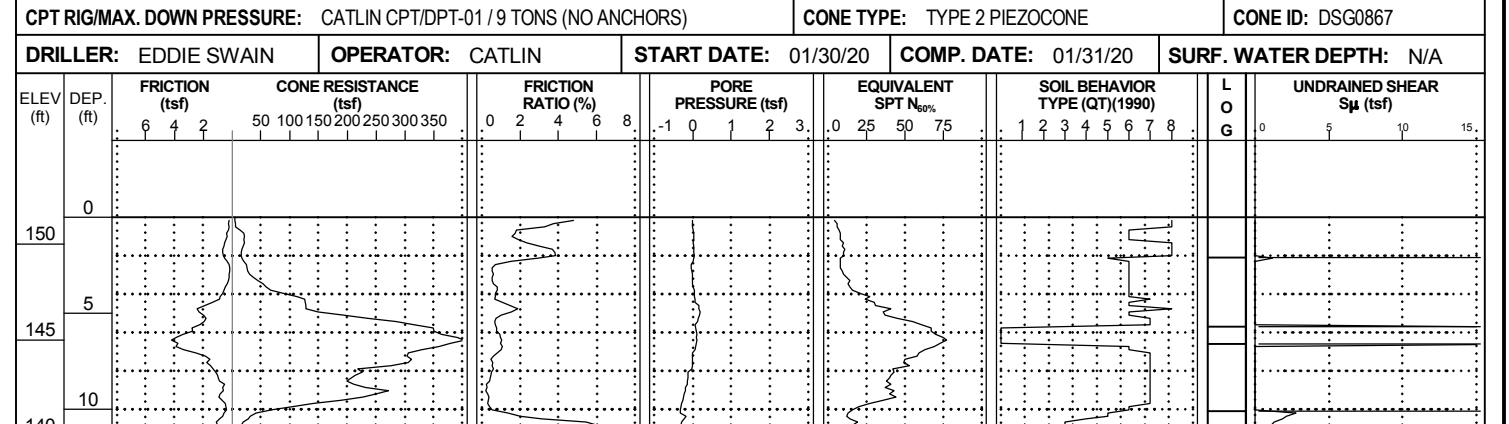

(0 HR. GROUNDWATER ESTIMATED FROM PORE PRESSURE)  
Boring Terminated at Elevation 139.0 ft

PORE PRESSURE NOT CONDUSIVE TO ESTIMATING GROUND WATER

NCDOT CPT DOUBLE (PORTRAIT) NO-LITH 15987\_GEO\_RDWY\_CATLIN\_GTM-DRILLED\_REVISED.GPJ\_NCDOT\_CATLIN.GDT\_07/30/20

# CONE PENETROMETER TEST BORING REPORT



WBS: 47533.1.1	TIP: I-5987A	COUNTY: ROBESON/CUMBERLAND	GEOLOGIST: S. HUDSON
SITE DESCRIPTION: I-95 CUMBERLAND/ROBESON COUNTIES FROM US 301 (EXIT 22) TO I-95 BUSINESS/US 301 (EXIT 40)			GROUND WTR (ft)
BORING NO.: Y3_2000	STATION: 22+15	OFFSET: 5 ft RT	ALIGNMENT: -Y3-
COLLAR ELEV.: 165.5 ft	TOTAL DEPTH: 32.5 ft	NORTHING: 370,682	EASTING: 2,000,590
CPT RIG/MAX. DOWN PRESSURE: CATLIN CPT/DPT-01 / 9 TONS (NO ANCHORS)		CONE TYPE: TYPE 2 PIEZOCONE	
DRILLER: EDDIE SWAIN		OPERATOR: CATLIN	
START DATE: 02/28/20		COMP. DATE: 02/28/20	
SURF. WATER DEPTH: N/A			

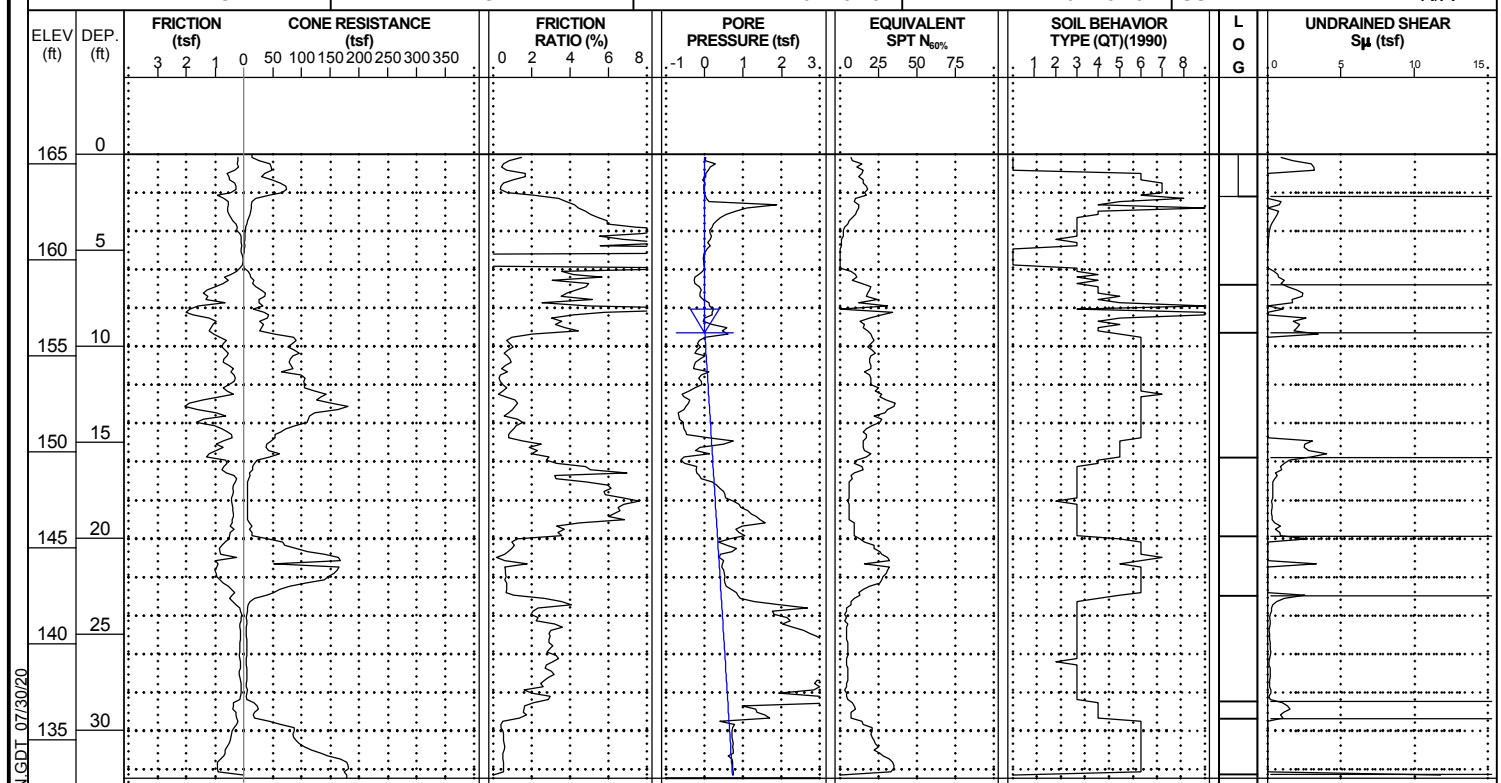

(0 HR. GROUNDWATER ESTIMATED FROM PORE PRESSURE)  
Boring Terminated at Elevation 133.0 ft

WBS: 47533.1.1	TIP: I-5987A	COUNTY: ROBESON/CUMBERLAND	GEOLOGIST: S. HUDSON
SITE DESCRIPTION: I-95 CUMBERLAND/ROBESON COUNTIES FROM US 301 (EXIT 22) TO I-95 BUSINESS/US 301 (EXIT 40)			GROUND WTR (ft)
BORING NO.: Y3_2400	STATION: 26+15	OFFSET: 4 ft RT	ALIGNMENT: -Y3-
COLLAR ELEV.: 171.9 ft	TOTAL DEPTH: 52.4 ft	NORTHING: 370,970	EASTING: 2,000,868
CPT RIG/MAX. DOWN PRESSURE: CATLIN CPT/DPT-01 / 9 TONS (NO ANCHORS)		CONE TYPE: TYPE 2 PIEZOCONE	
DRILLER: EDDIE SWAIN		OPERATOR: CATLIN	
START DATE: 02/28/20		COMP. DATE: 02/28/20	
SURF. WATER DEPTH: N/A			

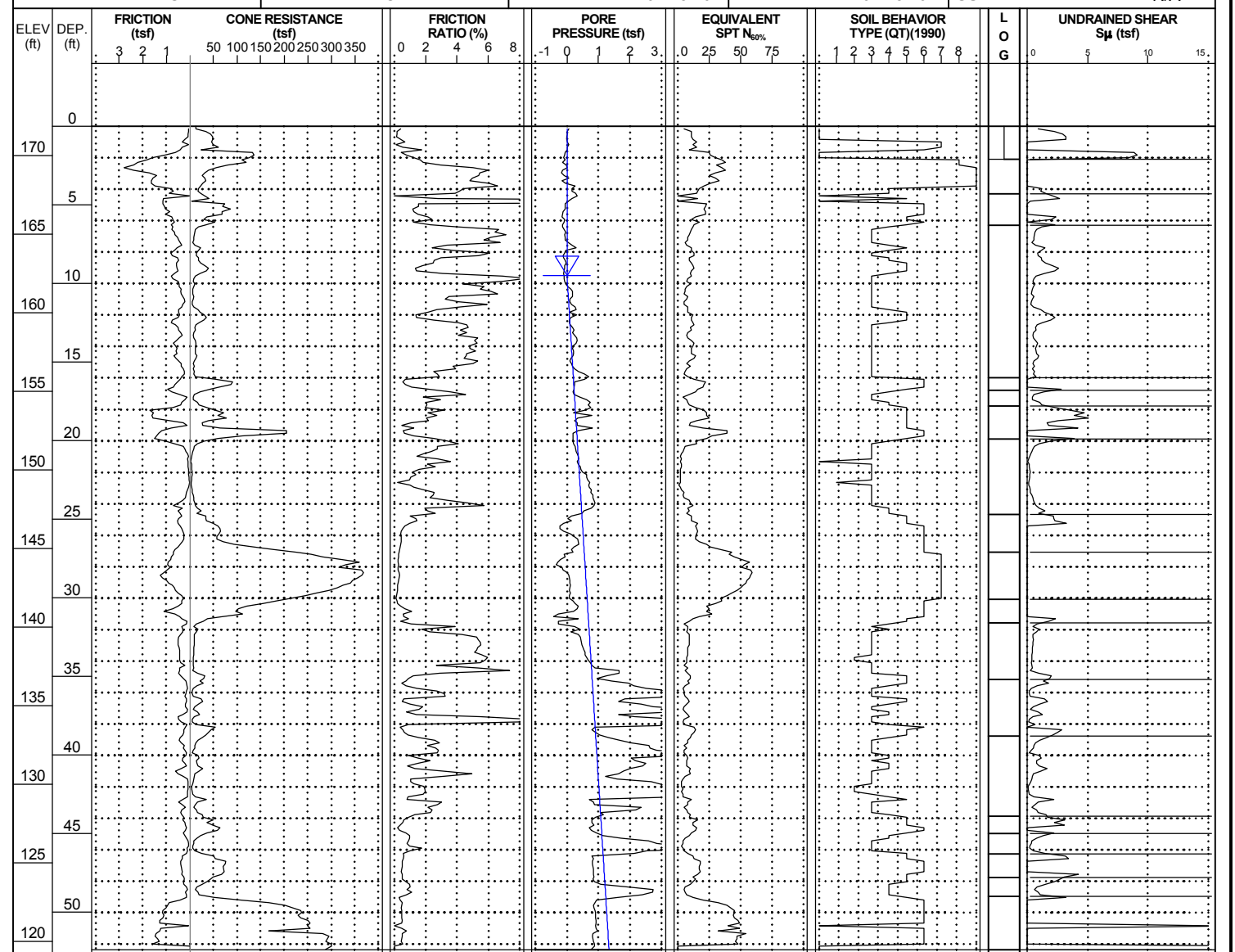

(0 HR. GROUNDWATER ESTIMATED FROM PORE PRESSURE)  
Boring Terminated at Elevation 119.5 ft

NCDOI CPT DOUBLE (PORTRAIT) NO-LITH I5987 GEO RDWY CATLIN GIM-DRILLED REVISED.GPJ NCDOT\_CATLIN.GDT 07/30/20