

FRONT ELEVATION OF UPPER PRECAST PANEL

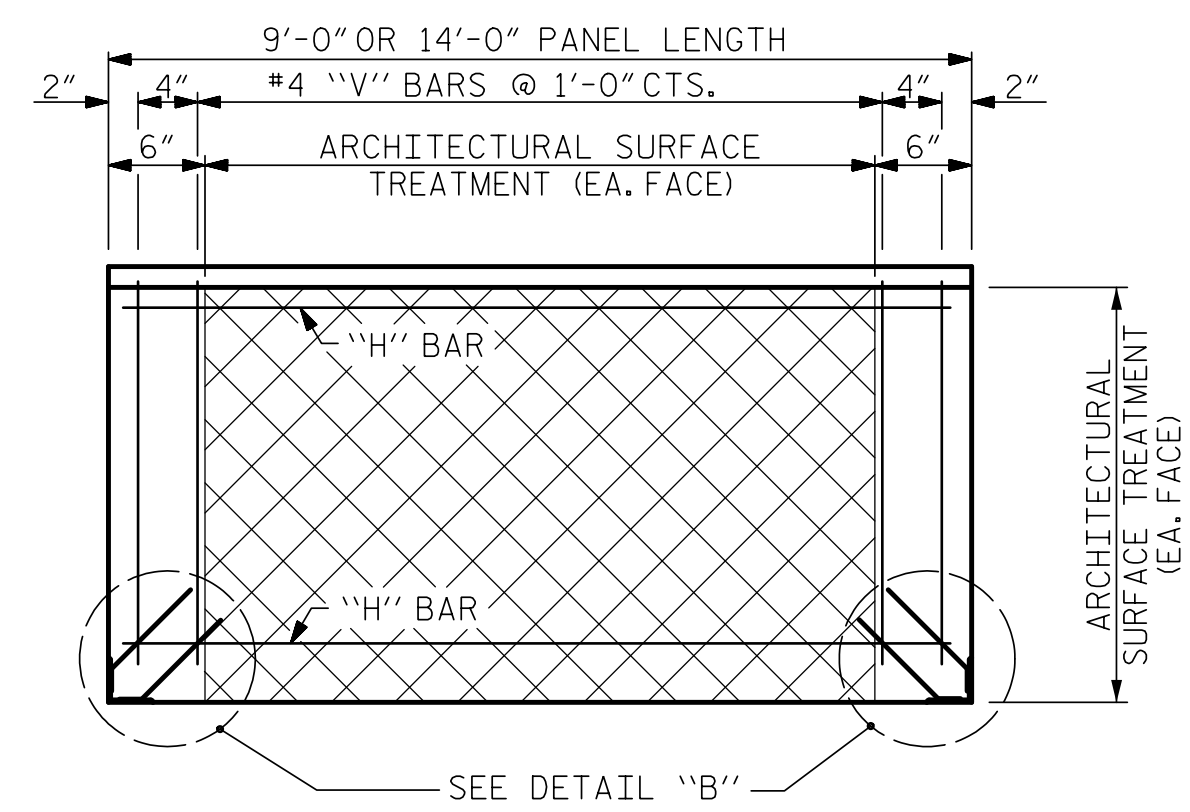

FRONT ELEVATION OF BOTTOM PRECAST PANEL

QUANTITIES FOR ONE PRECAST PANEL (FOR 10'-0" PILE SPACING)

PANEL HEIGHT	CLASS AA CONCRETE C.Y.	BAR TYPES											
		HORIZONTAL						VERTICAL					
		NO.	BAR	SIZE	TYPE	LENGTH	WEIGHT (lb)	NO.	BAR	SIZE	TYPE	LENGTH	WEIGHT (lb)
2'-0"	0.22	3	H1	#4	STR	8'-8"	17	11	V1	#4	STR	1'-8"	12
3'-0"	0.33	4	H2	#4	STR	8'-8"	23	11	V2	#4	STR	2'-8"	20
4'-0"	0.44	5	H3	#4	STR	8'-8"	29	11	V3	#4	STR	3'-8"	27

QUANTITIES FOR ONE PRECAST PANEL (FOR 15'-0" PILE SPACING)

PANEL HEIGHT	CLASS AA CONCRETE C.Y.	BAR TYPES											
		HORIZONTAL						VERTICAL					
		NO.	BAR	SIZE	TYPE	LENGTH	WEIGHT (lb)	NO.	BAR	SIZE	TYPE	LENGTH	WEIGHT (lb)
3'-0"	0.52	5	H1	#4	STR	13'-8"	46	16	V1	#4	STR	2'-8"	29
4'-0"	0.69	6	H2	#4	STR	13'-8"	55	16	V2	#4	STR	3'-8"	39
5'-0"	0.86	7	H3	#4	STR	13'-8"	64	16	V3	#4	STR	4'-8"	50
6'-0"	1.04	8	H4	#4	STR	13'-8"	73	16	V4	#4	STR	5'-8"	61

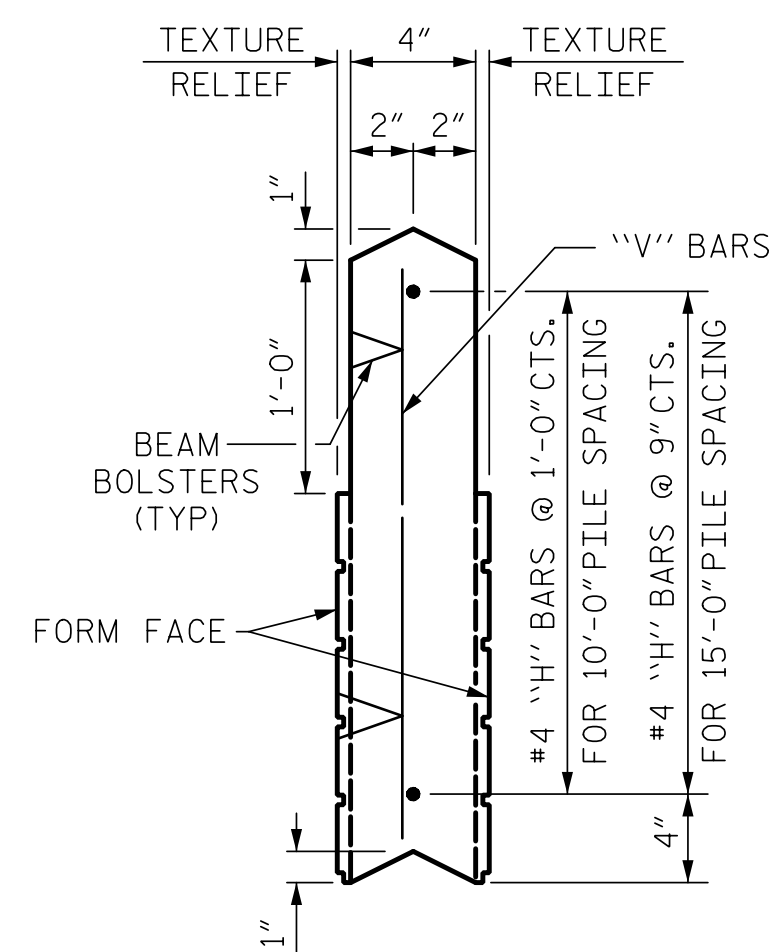
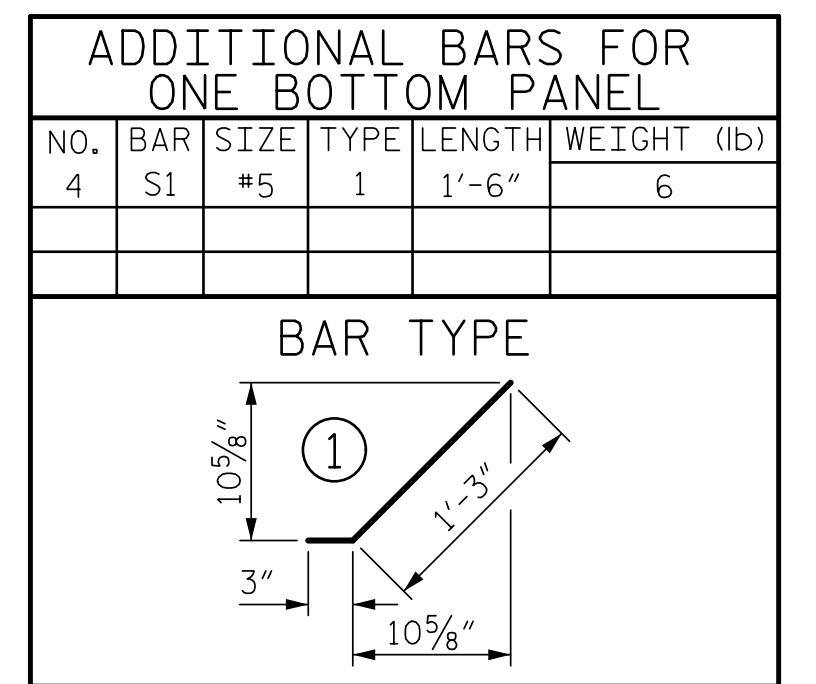

UPPER PANEL

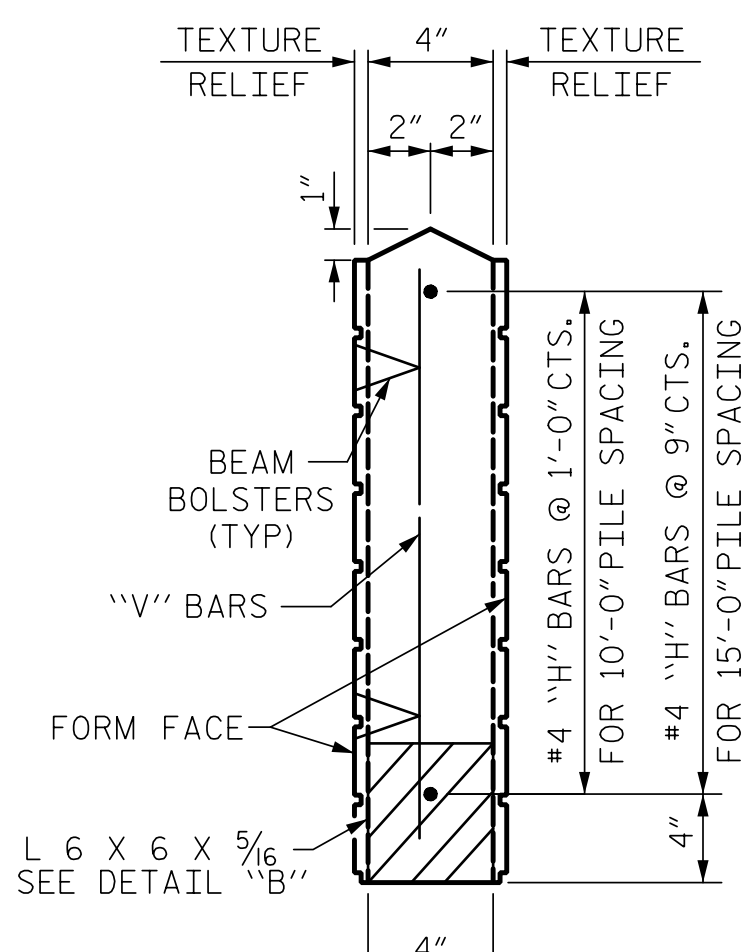

BOTTOM PANEL

SECTION THROUGH PRECAST PANELS

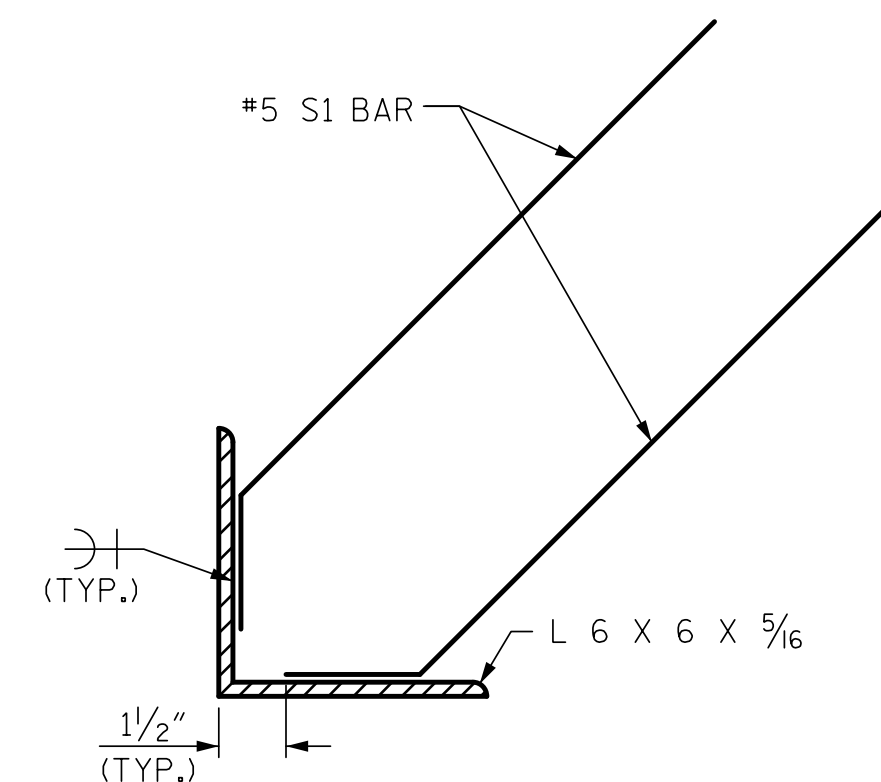

DETAIL "B"

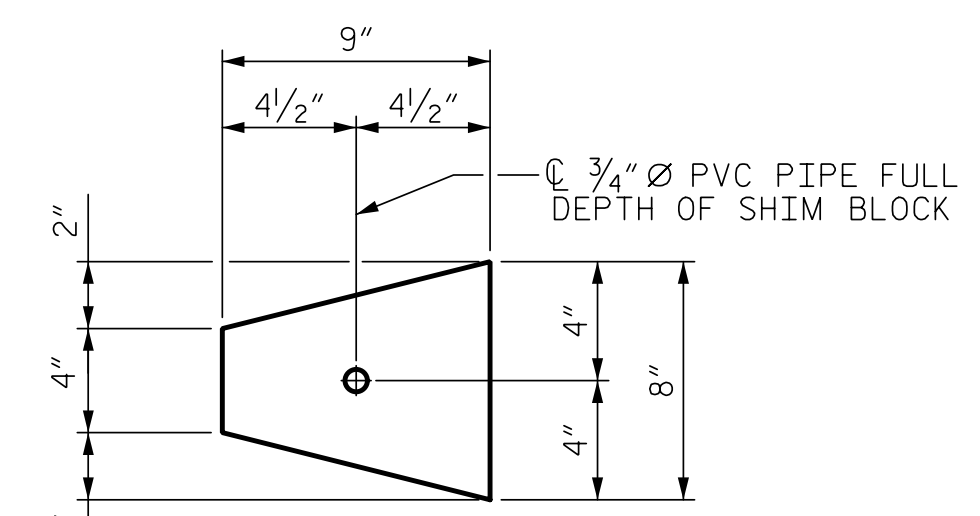

PLAN

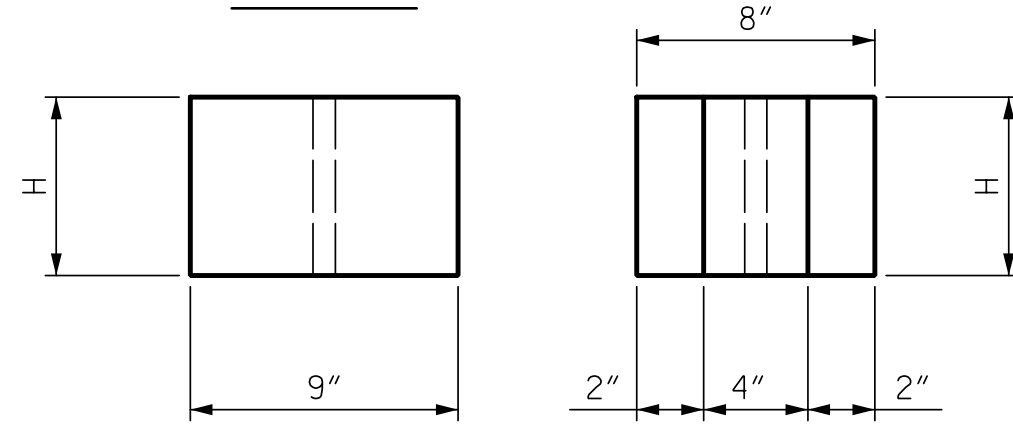

ELEVATION

END

CONCRETE SHIM BLOCK

H = 3', 6" or 1'-0"

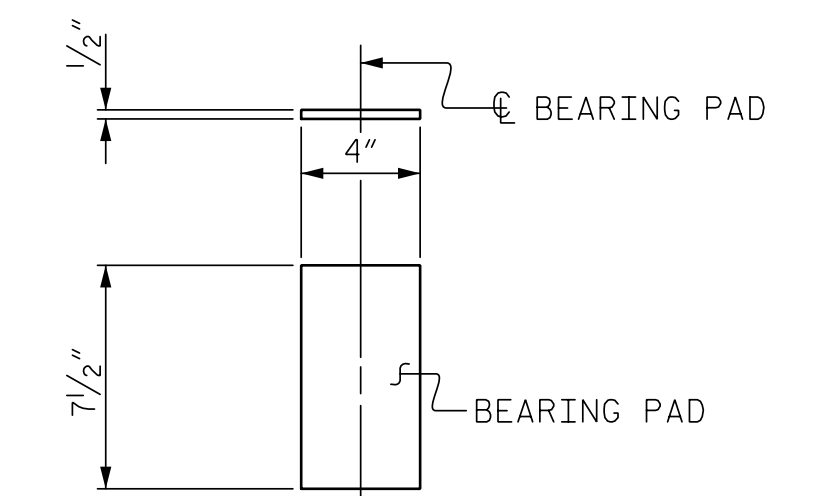

ELASTOMERIC BEARING DETAILS

ELASTOMER IN BEARINGS SHALL BE 50 DUROMETER HARDNESS.

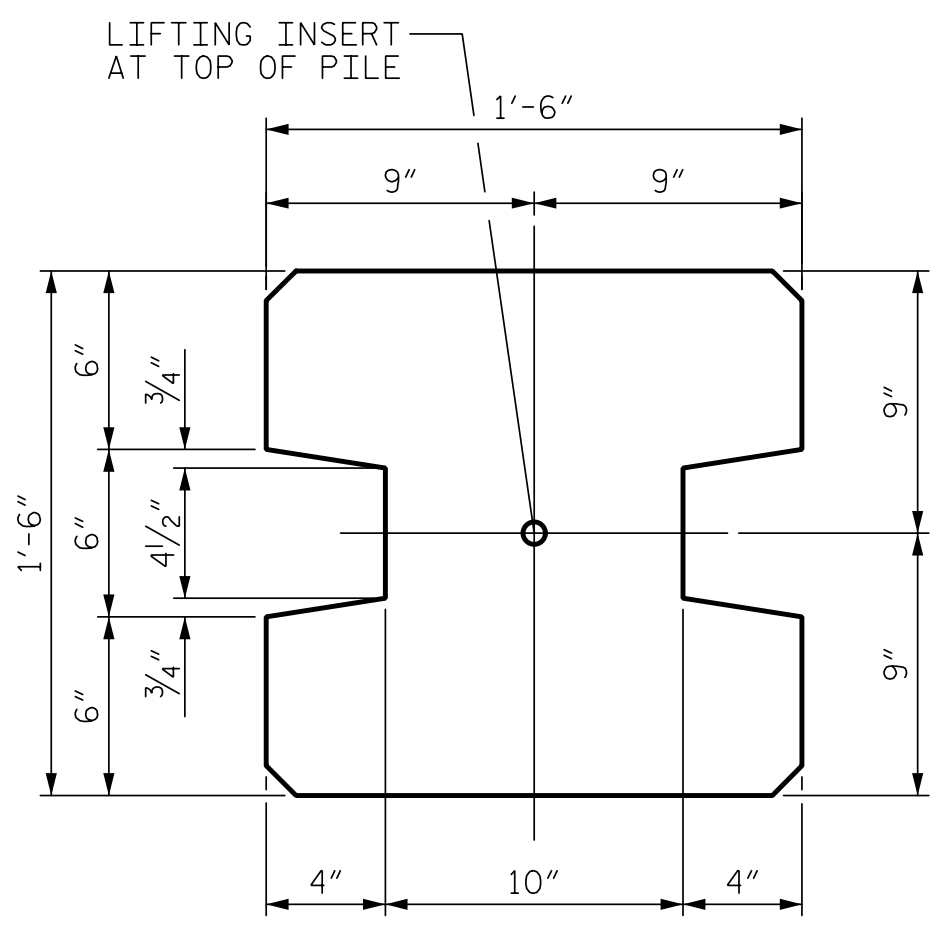

TYPE - I (AREA = 1.9444 SQ. FT.)

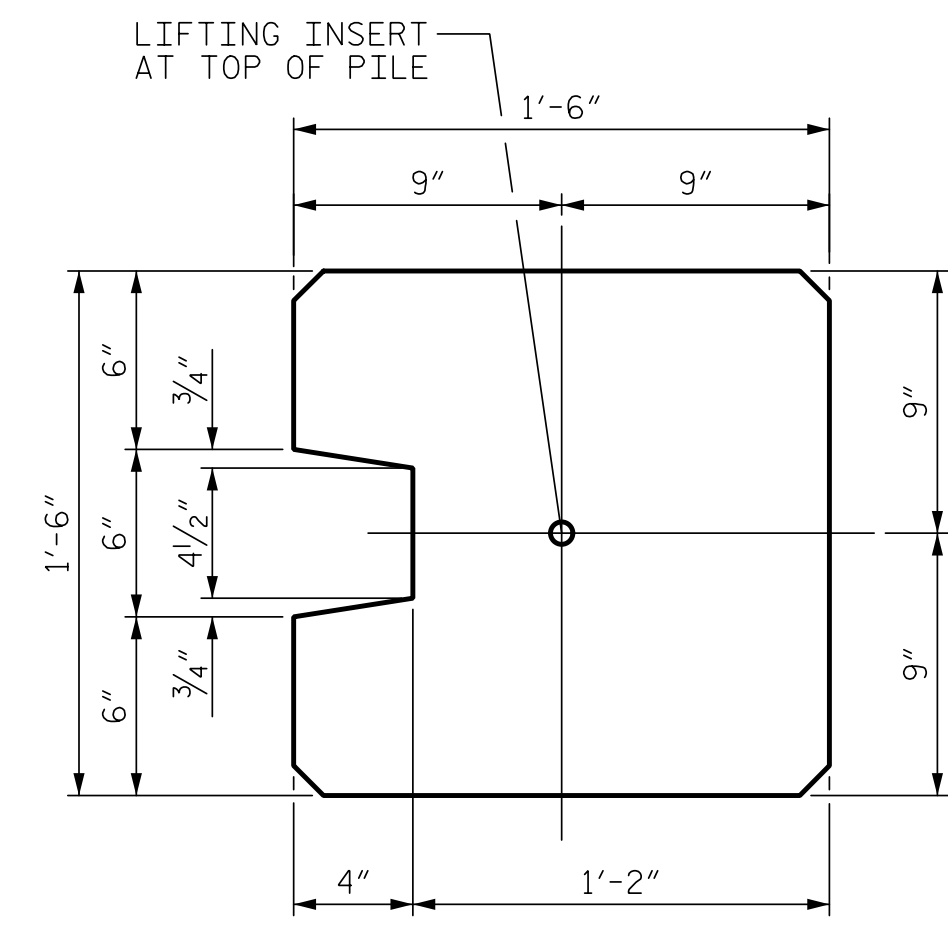

TYPE - II (AREA = 2.0903 SQ. FT.)

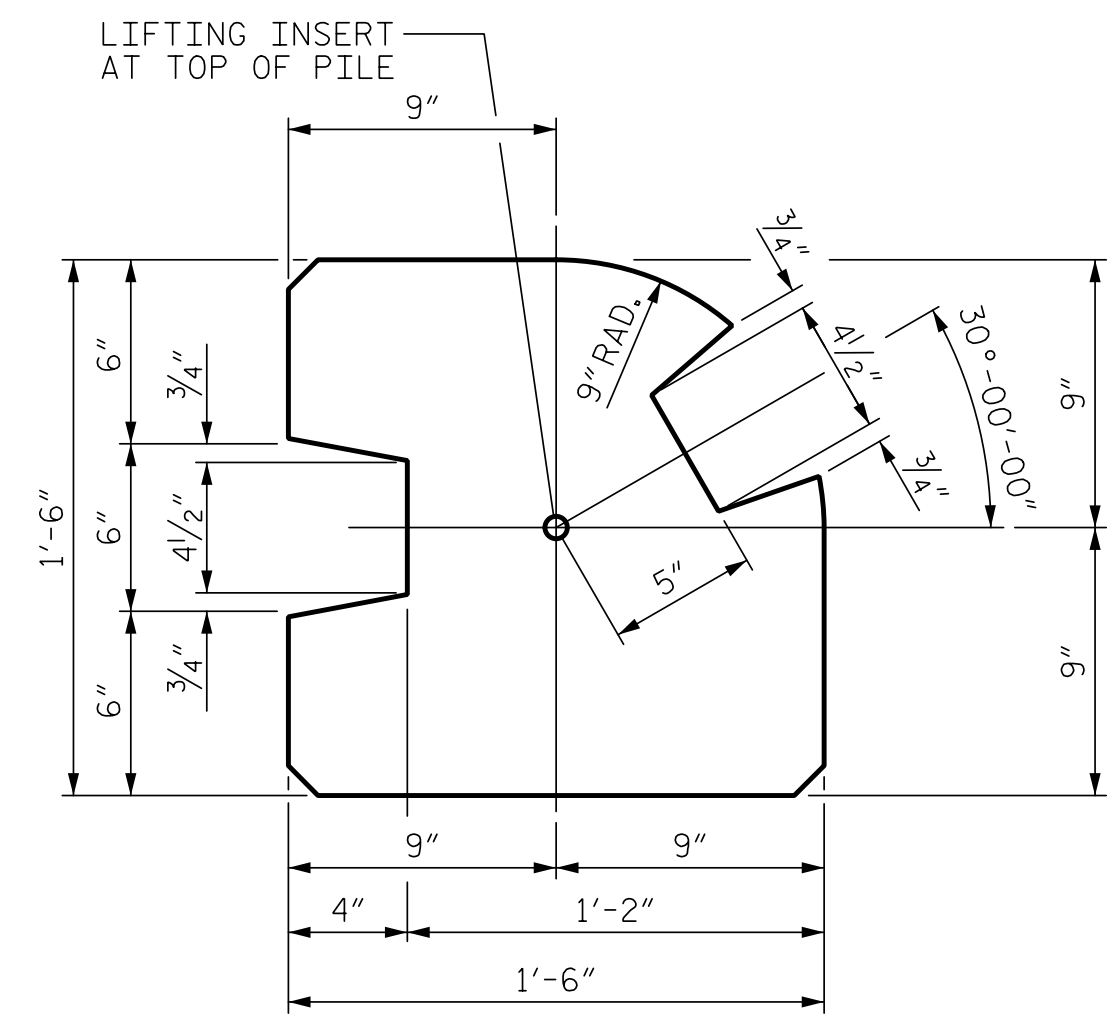

TYPE - III (AREA = 1.8336 SQ. FT.)

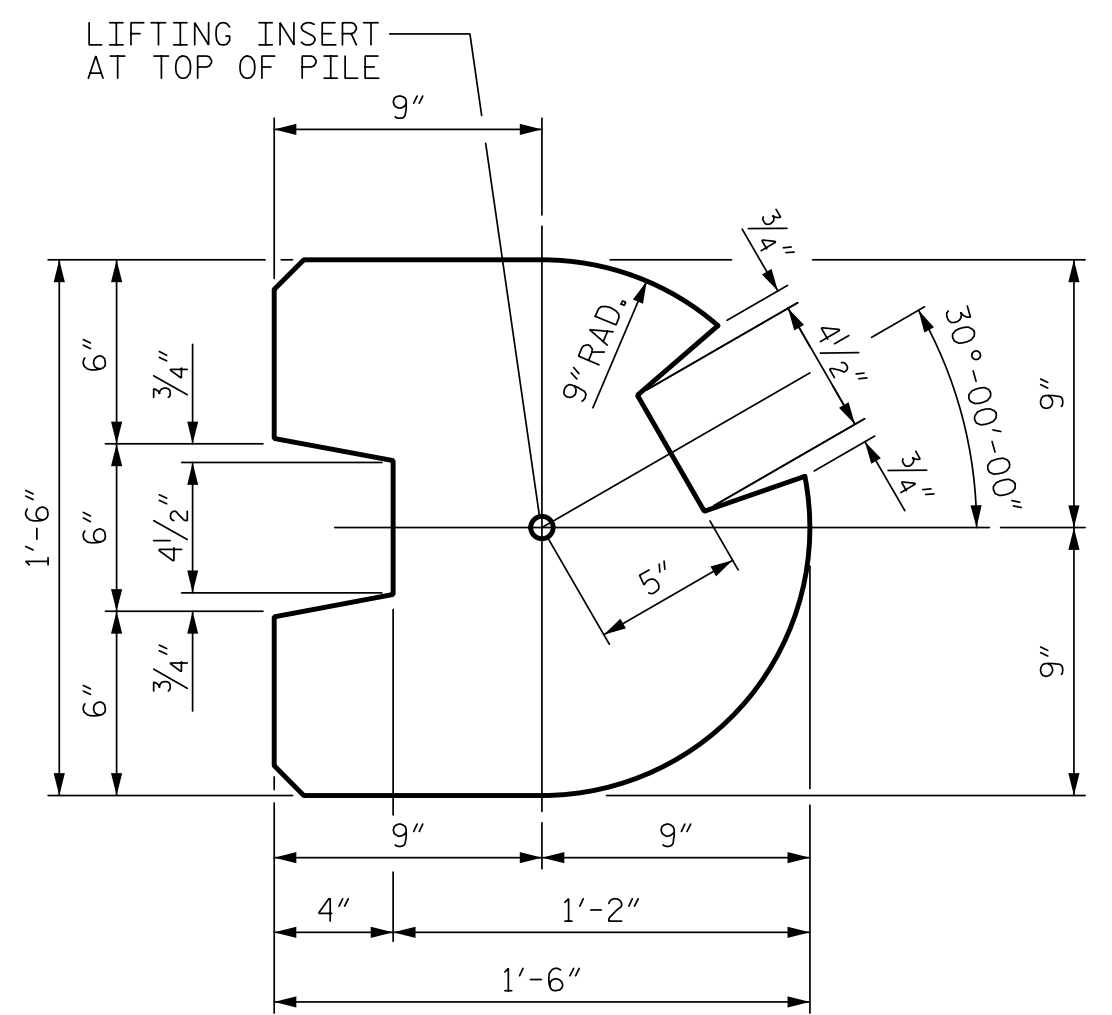

TYPE - III (ALT.) (AREA = 1.7163 SQ. FT.)

PILE DETAIL

(ALL CORNERS TO BE CHAMFERED 1")

PROJECT NO. I-5987A
ROBESON COUNTY
STATION: 10+00.00 -NW8-

SHEET 3 OF 4

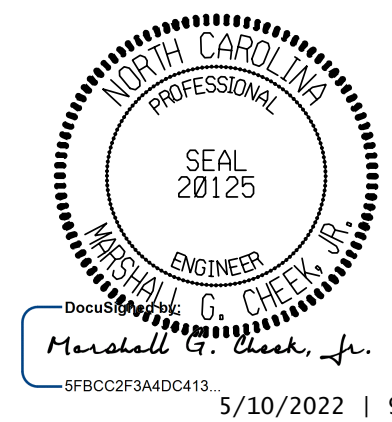

DOCUMENT NOT CONSIDERED FINAL UNLESS ALL SIGNATURES COMPLETED
TGS ENGINEERS
706 HILLSBOROUGH STREET SUITE 200
RALEIGH, NC 27603
PH (919) 773-8887
CORP. LICENSE NO.: C-0275

STATE OF NORTH CAROLINA
DEPARTMENT OF TRANSPORTATION
RALEIGH
STANDARD
SOUND BARRIER WALL
-NW8-
DETAILS

REVISIONS						SHEET NO.
NO.	BY:	DATE:	NO.	BY:	DATE:	W8-3
1			3			TOTAL SHEETS
2			4			4

STD. NO. SBW2

ASSEMBLED BY : ZCS	DATE : 12/21
CHECKED BY : MGC	DATE : 1/22
DRAWN BY : MAA 6/11	REV. 1/15/14 RWN/TMG
CHECKED BY : CM 6/11	REV. 10/17 MAA/THC
	REV. 5/18 MAA/THC