

# MSE RETAINING WALL NO. W1B PLAN

GEOTECHNICAL ENGINEER

ENGINEER

SEAL 040231

DocuSigned by: **Matthew J. Alexander** 04/19/2022

DOCUMENT NOT CONSIDERED FINAL UNLESS ALL SIGNATURES COMPLETED

NOTES:  
 FOR 4" SLOPE PROTECTION, SEE "CONCRETE SLOPE PROTECTION" SHEET.  
 FOR CONCRETE DITCH, SEE SHEET W-12.

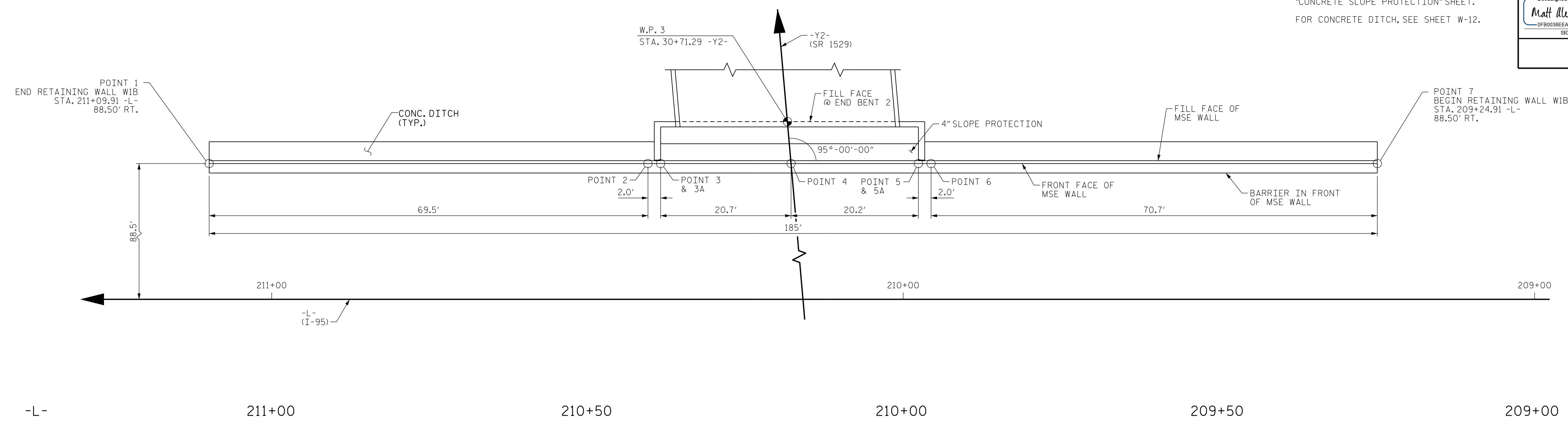

# MSE RETAINING WALL NO. W1B ENVELOPE

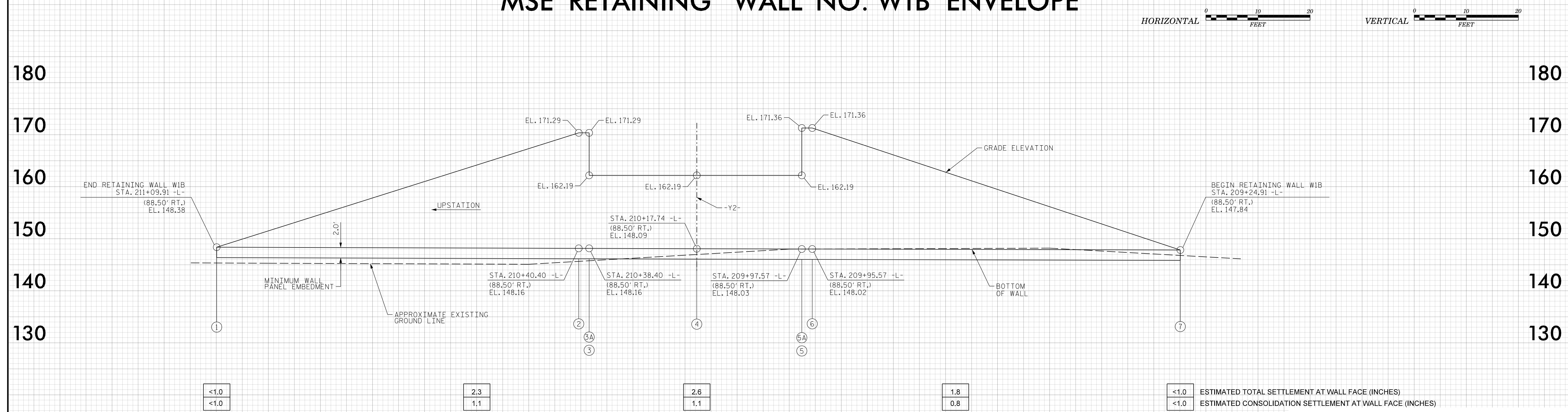

PROJECT NO.: 47533.1.2 (I-5987A)  
 ROBESON COUNTY  
 STATION: -Y2- STA 30+71.29  
 SHEET 2 OF 11 WALL ID NO. W1B

ESTIMATED MSE WALL QUANTITY* (SQUARE FEET)	
MSE RETAINING WALL NO. W1B	2,730 SF

\* QUANTITY INCLUDES MINIMUM 2 FT. EMBEDMENT AND 0.5 FT. EXTENSION

Prepared in the Office of:

**Terracon**

Consulting Engineers and Scientists

2401 BRENTWOOD ROAD, SUITE 107  
 RALEIGH, NORTH CAROLINA 27604  
 NC REGISTERED ENGINEERING FIRM: F-0869  
 NC REGISTERED GEOLOGIC FIRM: C-367

## MSE ABUTMENT RETAINING WALL NO. W1B PLAN AND ENVELOPE

REVISIONS					
NO.	BY	DATE	NO.	BY	DATE
1			3		
2			4		

PREPARED BY: ALEXANDER, M. J.	DATE: 4/2022
REVIEWED BY: RIGGS, A. F.	DATE: 4/2022

SHEET NO. W-2