

CONCRETE SILL DETAIL

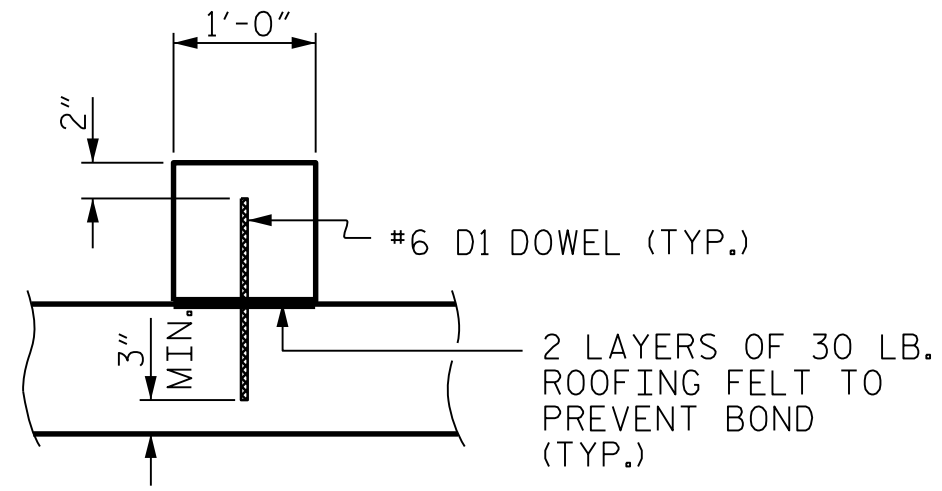

SECTION THROUGH SILL
DOWELS MAY BE PUSHED INTO GREEN CONCRETE AFTER SLAB HAS BEEN FLOAT FINISHED.

THE CONTRACTOR'S ATTENTION IS CALLED TO THE FACT THAT THE NATIVE MATERIAL BACKFILL SHALL BE PLACED PRIOR TO THE CASTING OF THE ROOF SLAB.

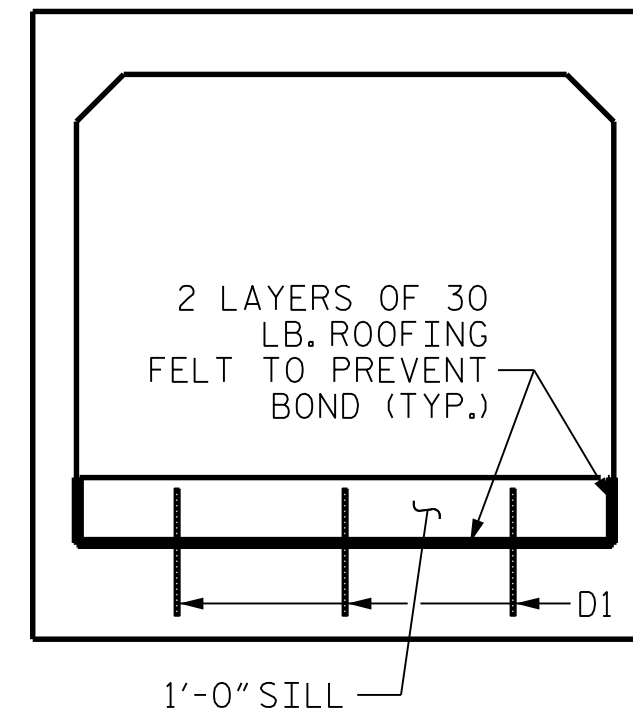

ELEVATION
SILLS AT INLET & OUTLET ENDS

NOTES:

CULVERT FLOOR SLAB IS BURIED 1 FOOT BELOW EXISTING STREAM BED. BACKFILL WITH NATIVE MATERIAL TO SILL HEIGHT IN ALL BARRELS.

NATIVE MATERIAL BETWEEN SILLS IN THE CULVERT SHALL PROVIDE A CONTINUOUS FLOW CHANNEL.

NATIVE MATERIAL CONSISTS OF MATERIAL THAT IS EXCAVATED FROM THE STREAM OR FLOODPLAIN AT THE PROJECT SITE DURING CONSTRUCTION. ONLY MATERIAL THAT IS EXCAVATED FROM THE STREAM BED MAY BE USED TO LINE CULVERT BARRELS. AT THE CONTRACTOR'S OPTION, RIP RAP MAY BE USED TO SUPPLEMENT THE NATIVE MATERIAL IN THE BARREL.

IF RIP RAP IS USED TO LINE THE FLOW CULVERT BARREL, NATIVE MATERIAL SHOULD BE PLACED ON TOP TO FILL VOIDS AND PROVIDE A FLAT SURFACE FOR ANIMAL PASSAGE.

NATIVE MATERIAL IS SUBJECT TO APPROVAL BY THE ENGINEER AND MAY BE SUBJECT TO PERMIT CONDITIONS.

SILLS ARE TO BE 1 FOOT, CAST SEPARATELY AND ATTACHED BY DOWELS.

TOP OF SILLS SHOULD MATCH STREAM BED ELEVATION.

THE ENTIRE COST OF WORK REQUIRED TO PLACE EXCAVATED OR SUPPLEMENTAL MATERIAL AS SHOWN ON THE PLANS SHALL BE INCLUDED IN THE LUMP SUM PRICE FOR CULVERT EXCAVATION.

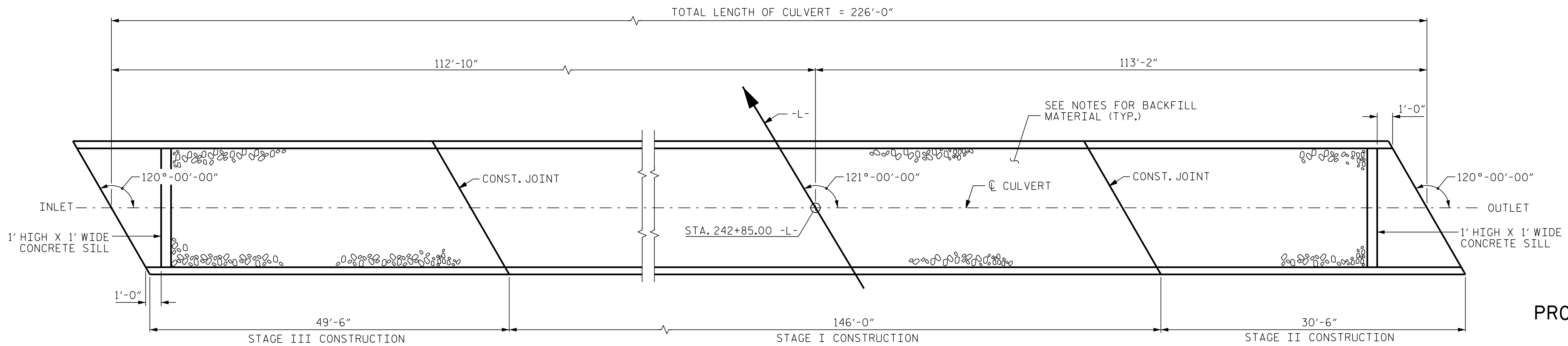

PLAN

PROJECT NO. I-5987A
ROBESON COUNTY
STATION: 242+85.00 -L-

SHEET 6 OF 8

STATE OF NORTH CAROLINA
DEPARTMENT OF TRANSPORTATION
RALEIGH

**DETAILS OF SILLS
FOR
CONCRETE BOX CULVERT**

DOCUMENT NOT CONSIDERED
FINAL UNLESS ALL
SIGNATURES COMPLETED

CDM Smith
CDM SMITH
5400 Glenwood Ave, Suite 400
Raleigh, NC 27612-3228
NC COA No. F-1255



DWG. No. _____
DRAWN BY : JJR DATE : 9/21
CHECKED BY : THF DATE : 11/21
DESIGN ENGINEER : VDK DATE : 12/21

REVISIONS						SHEET NO.
NO.	BY:	DATE:	NO.	BY:	DATE:	C20-6
1			3			TOTAL SHEETS
2			4			8