

**STAGE II - PLAN OF ROOF SLAB**

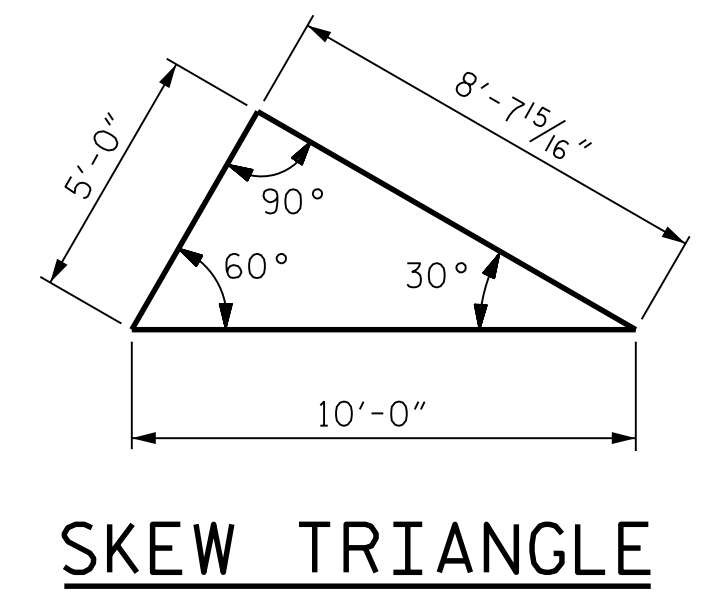

**TOTAL STRUCTURE QUANTITIES STAGE II**

FOUNDATION COND. MAT'L	29 TONS
CULVERT EXCAVATION	LUMP SUM
CLASS A CONCRETE	
BARREL @ 0.955 CY/FT	29.1 C.Y.
WINGS ETC.	14.6 C.Y.
SILL	0.3 C.Y.
HEADWALL	0.5 C.Y.
<b>TOTAL</b>	<b>44.5 C.Y.</b>
REINFORCING STEEL	
BARREL & SILL	3,959 LBS.
WINGS ETC.	959 LBS.
<b>TOTAL</b>	<b>4,918 LBS.</b>

REINFORCING BAR SCHEDULE					
STAGE II					
BAR	NO.	SIZE	TYPE	LENGTH	WEIGHT
A1	122	#4	3	5'-10"	475
A2	122	#4	3	6'-11"	564
A100	50	#5	STR	9'-0"	469
A101	2	#5	STR	8'-6"	18
A102	2	#5	STR	7'-8"	16
A103	2	#5	STR	6'-9"	14
A104	2	#5	STR	5'-11"	12
A105	2	#5	STR	5'-0"	10
A106	2	#5	STR	4'-2"	9
A107	2	#5	STR	3'-4"	7
A108	2	#5	STR	2'-6"	5
A109	2	#5	STR	1'-7"	3
A200	50	#5	STR	9'-0"	469
A201	2	#5	STR	8'-6"	18
A202	2	#5	STR	7'-8"	16
A203	2	#5	STR	6'-9"	14
A204	2	#5	STR	5'-11"	12
A205	2	#5	STR	5'-0"	10
A206	2	#5	STR	4'-2"	9
A207	2	#5	STR	3'-4"	7
A208	2	#5	STR	2'-6"	5
A209	2	#5	STR	1'-7"	3
B1	62	#4	STR	8'-5"	349
B2	122	#4	STR	6'-4"	516
C1	36	#4	STR	30'-4"	729
D1	3	#6	STR	1'-6"	7
G1	2	#4	STR	10'-5"	14
S1	12	#6	STR	10'-5"	188

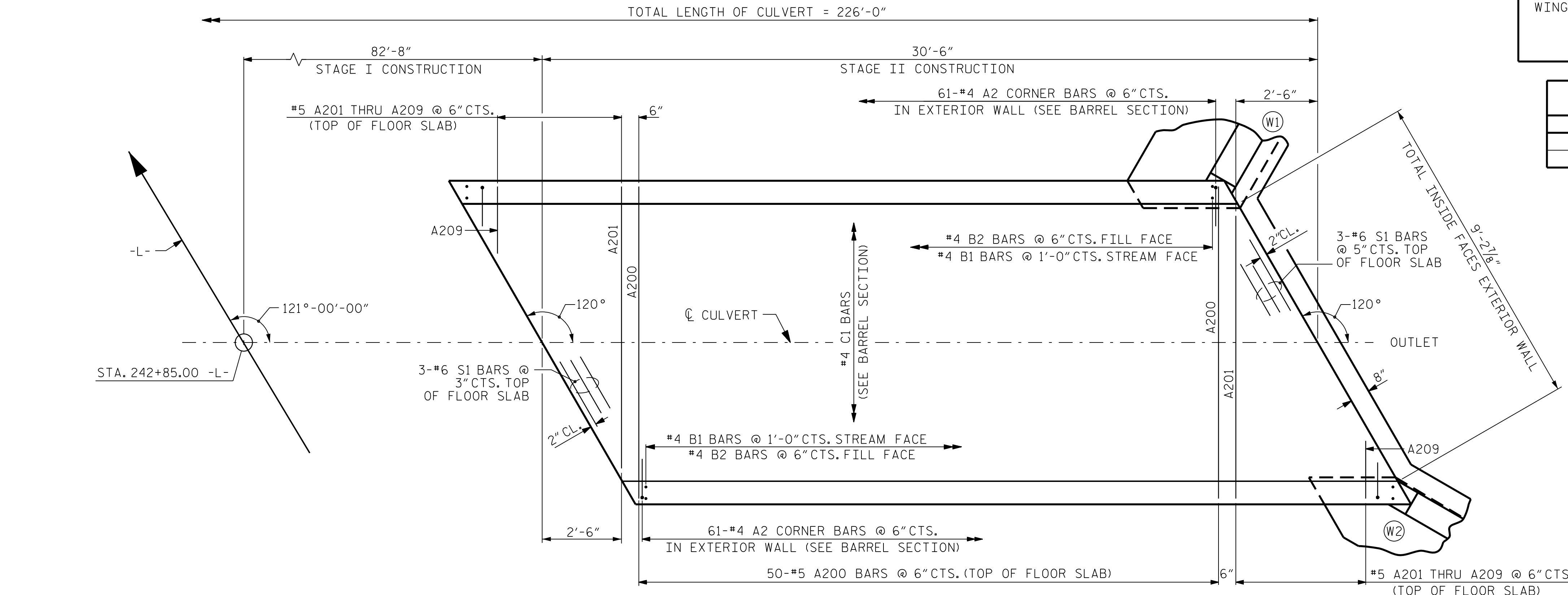

**STAGE II - PLAN OF FLOOR SLAB**

**SPLICE LENGTHS CHART**

BAR	SIZE	SPLICE LENGTH
C1	#4	1'-10"

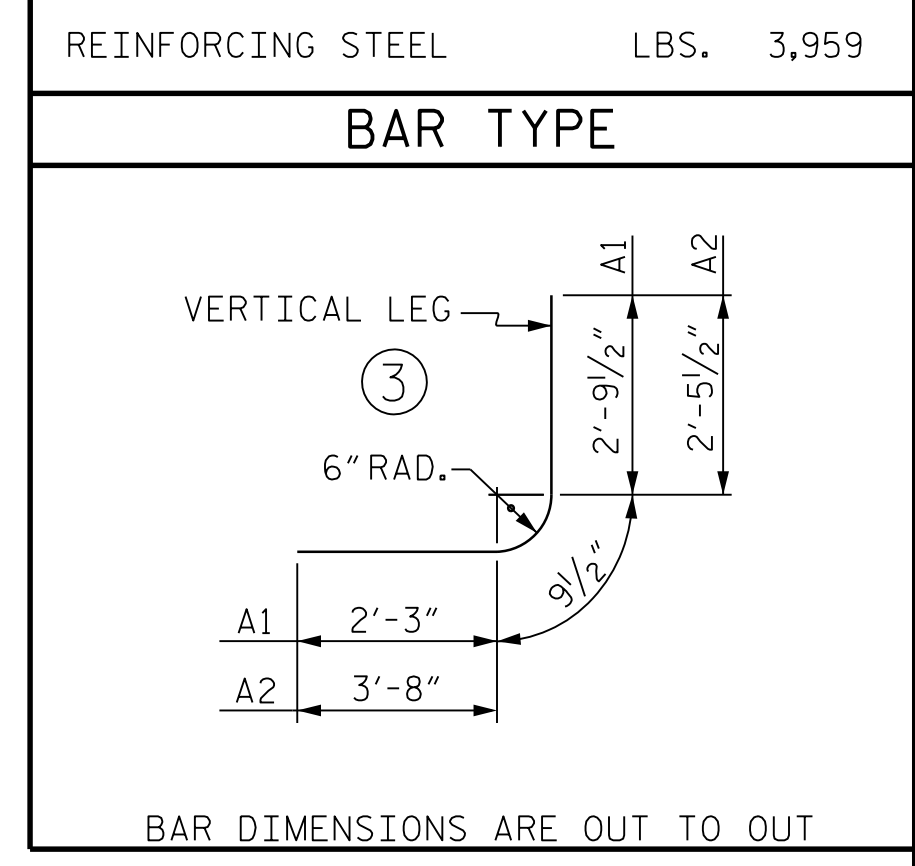

PROJECT NO. I-5987A  
ROBESON COUNTY  
 STATION: 242+85.00 -L-  
 SHEET 4 OF 8

STATE OF NORTH CAROLINA  
 DEPARTMENT OF TRANSPORTATION  
 RALEIGH  
 BARREL STANDARD  
 SINGLE 8 FT. X 7 FT.  
 CONCRETE BOX CULVERT  
 STAGE II

DOCUMENT NOT CONSIDERED FINAL UNLESS ALL SIGNATURES COMPLETED

**CDM Smith**  
 CDM SMITH  
 5400 Glenwood Ave, Suite 400  
 Raleigh, NC 27612-3228  
 NC COA No. F-1255

DRAWN BY: JJR DATE: 9/21  
 CHECKED BY: THF DATE: 11/21  
 DESIGN ENGINEER: VDK DATE: 12/21

DWG. No. \_\_\_\_\_

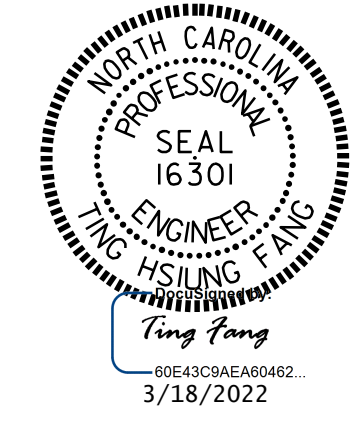

REVISIONS					
NO.	BY:	DATE:	NO.	BY:	DATE:
1			3		
2			4		

SHEET NO. **C20-4**  
 TOTAL SHEETS **8**