

PA202121331.02_I-5987A BridgeStructures\G01_001_I5987A_SMU_PS_001.dgn
3/8/2022 11:09:24 AM

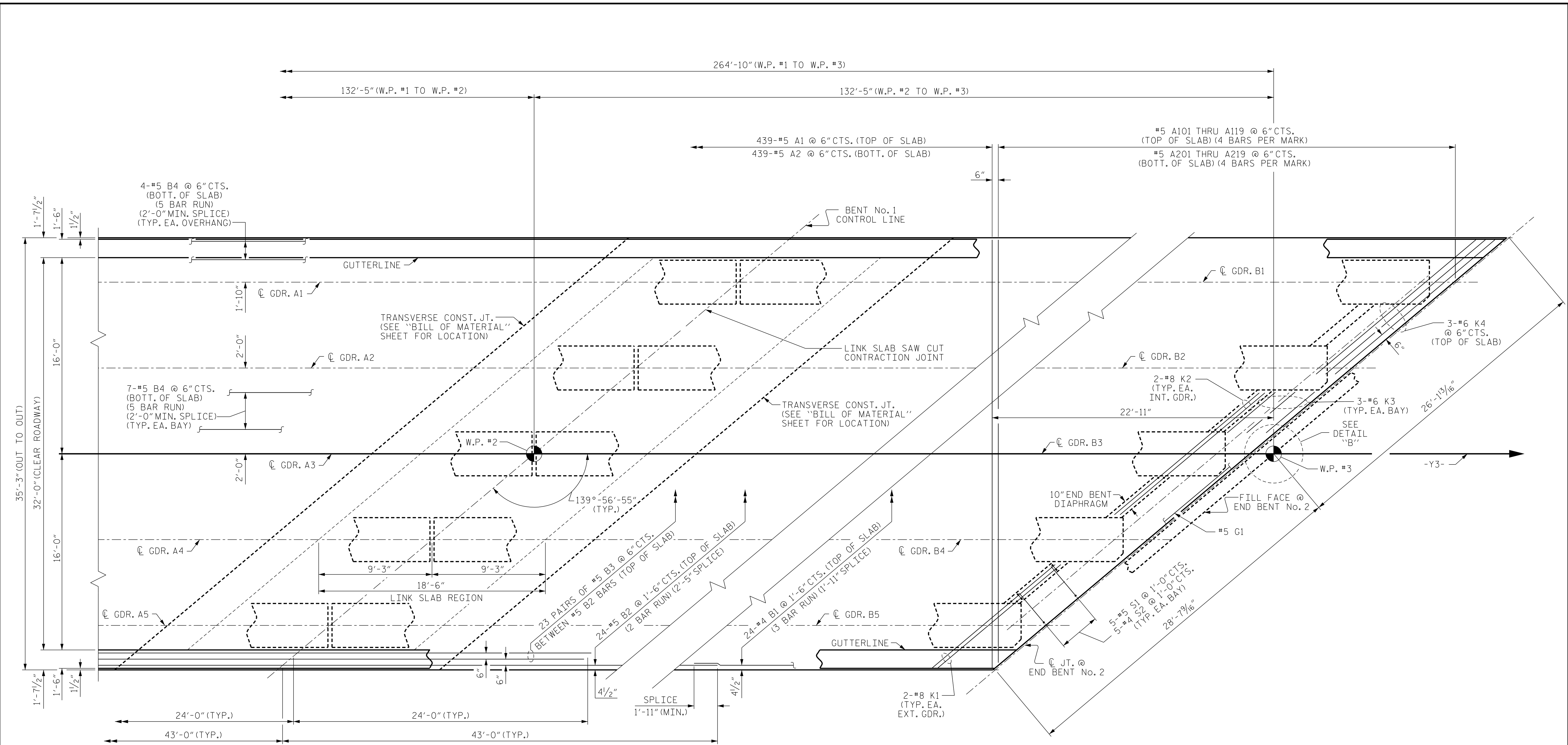

PLAN OF SPAN B

FOR LOCATIONS OF INTERMEDIATE STEEL DIAPHRAGMS, SEE "GIRDER LAYOUT" SHEET.

PROJECT NO. I-5987A
ROBESON COUNTY
 STATION: 30+04.11 -Y3-
 SHEET 2 OF 2

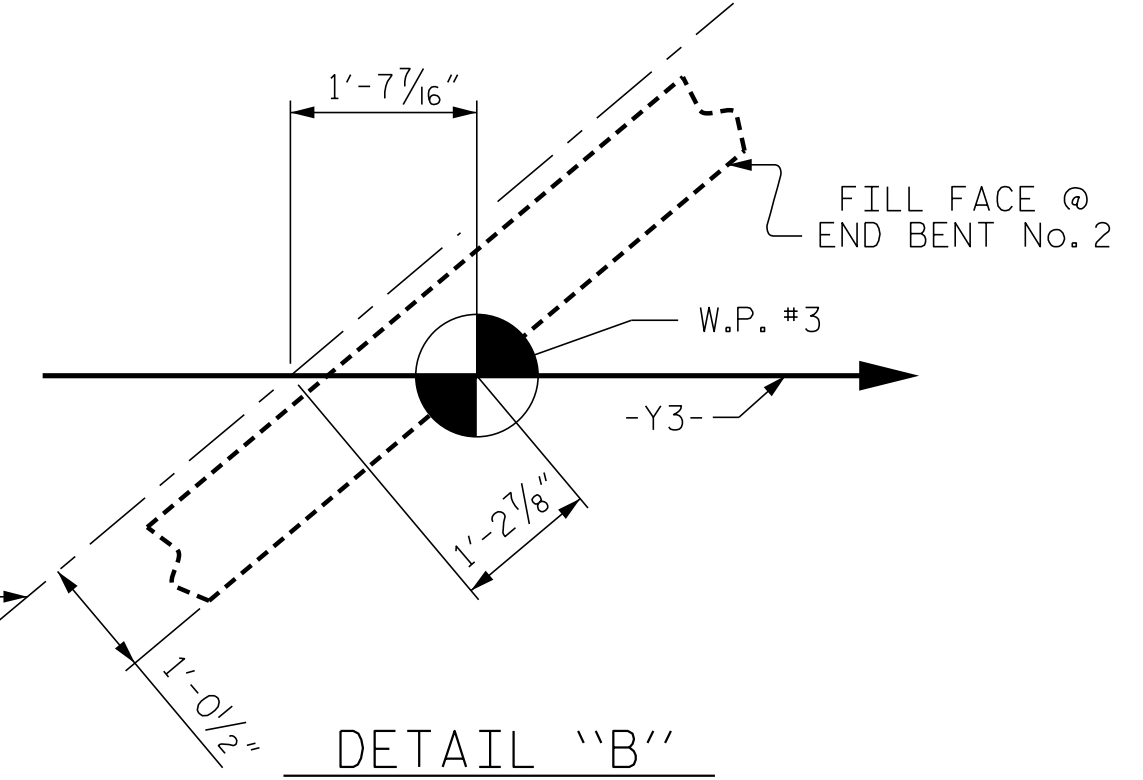

DRAWN BY: DAH/GMG DATE: 11/21
 CHECKED BY: J. DILWORTH DATE: 11/21

DOCUMENT NOT CONSIDERED FINAL
 UNLESS ALL SIGNATURES COMPLETED

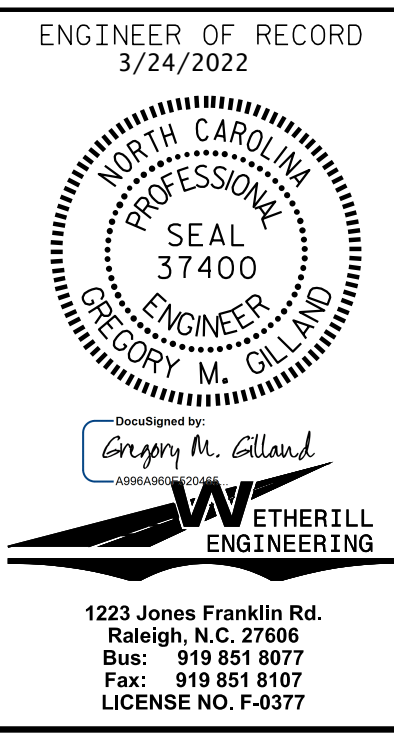

STATE OF NORTH CAROLINA DEPARTMENT OF TRANSPORTATION RALEIGH					
SUPERSTRUCTURE PLAN OF SPANS SPAN B					
REVISIONS					
NO.	BY:	DATE:	NO.	BY:	DATE:
1			3		
2			4		
					SHEET NO. S3-8
					TOTAL SHEETS 29